

HONDA

SERVICE MANUAL

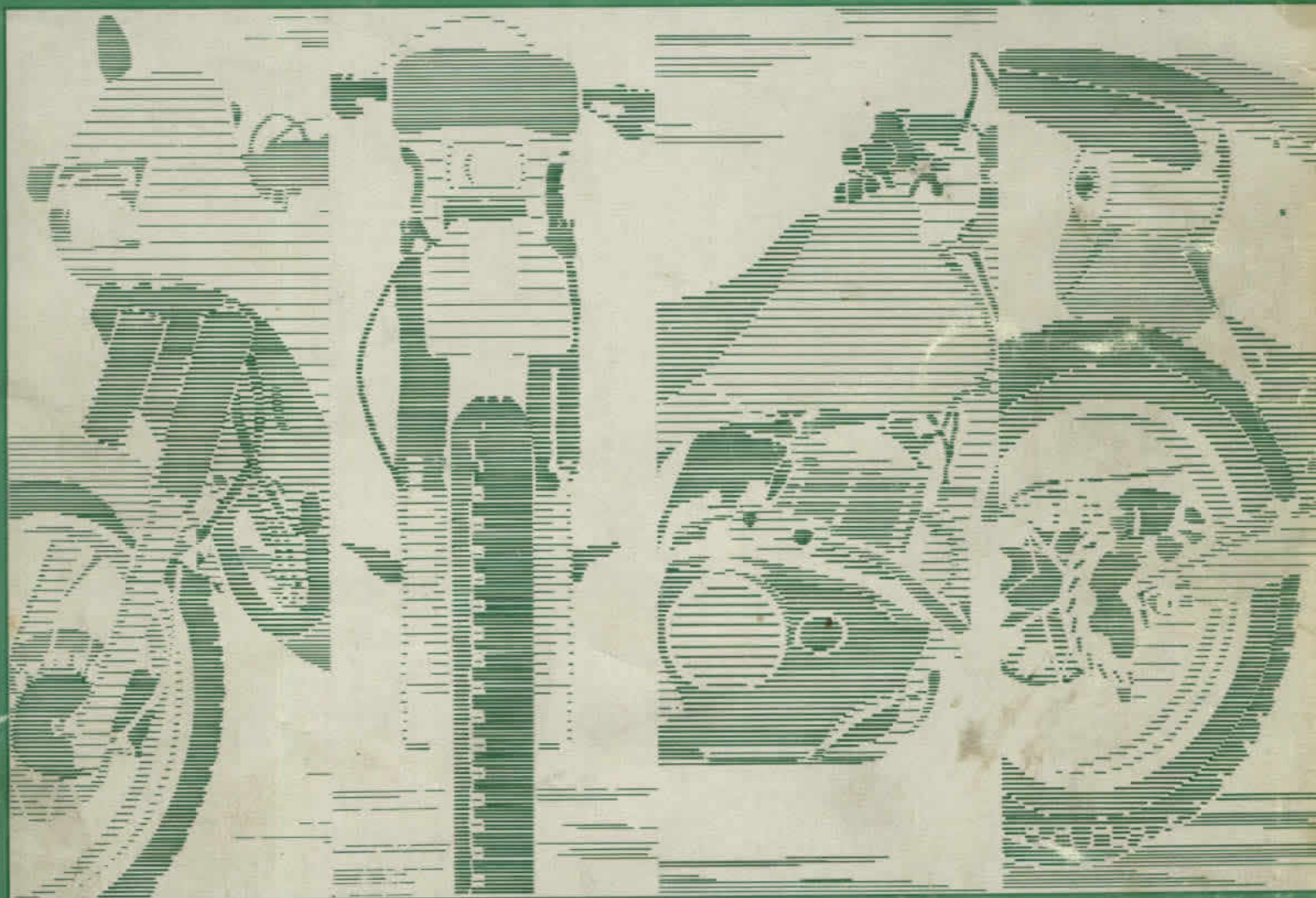

92-97
CR125R

Important Safety Notice

⚠ WARNING Indicates a strong possibility of severe personal injury or death if instructions are not followed.

CAUTION: Indicates a possibility of equipment damage if instructions are not followed.

NOTE: Gives helpful information.

Detailed descriptions of standard workshop procedures, safety principles and service operations are not included. It is important to note that this manual contains *some* warnings and cautions against some specific service methods which could cause **PERSONAL INJURY** to service personnel or could damage a vehicle or render it unsafe. Please understand that those warnings could not cover all conceivable ways in which service, whether or not recommended by Honda, might be done or of the possibly hazardous consequences of each conceivable way, nor could Honda investigate all such ways. Anyone using service procedures or tools, whether or not recommended by HONDA, *must satisfy himself thoroughly* that neither personal safety nor vehicle safety will be jeopardized by the service methods or tools selected.

Introduction

This service manual describes the service procedures for the CR125R.

Also available, but not necessary to service this model: The Honda Common Service Manual (Part Number: 61CM000) explains the theory of operation and provides basic service information for various systems common to all Honda motorcycles, scooters, ATVs and Pilots. It is an excellent source for those who want a greater knowledge of motorcycles and their component systems.

Performing the first scheduled maintenance is very important. It helps compensate for the initial wear that occurs during the break-in period.

Sections 1 and 3 apply to the whole motorcycle. Section 2 illustrates procedures for removal/installation of components that may be required to perform service described in the following sections. Sections 4 through 15 describe parts of the motorcycle, grouped according to location.

Find the section you want on this page, then turn to the table of contents on the first page of the section.

If you are not familiar with the Honda Power Port system, refer to Section 16, Technical Feature.















If you don't know the source of the trouble, go to Section 17 Troubleshooting.

Contents

	General Information	1
	Frame/Body Panels/Exhaust System	2
	Maintenance	3
Engine And Drive Train	Fuel System	4
	Cooling System	5
	Engine Removal/Installation	6
	Cylinder Head/Cylinder/Piston	7
	H.P.P. (Honda Power Port)	8
	Clutch/Kickstarter/Gearshift Linkage	9
	Crankcase/Crankshaft/Transmission	10
Chassis	Front Wheel/Suspension/Steering	11
	Rear Wheel/Suspension	12
	Brake System	13
Electrical	Ignition System/Alternator	14
	Wiring Diagram	15
	Technical Feature	16
	Troubleshooting	17
	Index	18

Symbols

The symbols used throughout this manual show specific service procedures. If supplementary information is required pertaining to these symbols, it would be explained specifically in the text without the use of the symbols.

	Replace the part(s) with new one(s) before assembly.
	Use special tool.
	Use optional tool. These tools are obtained as you order parts.
	Torque specification. 10 N·m (1.0 kg·m, 7 ft·lb)
	Use recommended engine oil. Use Honda Engine Oil (U.S.A. only) or an equivalent of the type specified.
	Use molybdenum oil solution (mixture of the engine oil and molybdenum grease with the ratio 1:1).
	Use multi-purpose grease (Lithium based multi-purpose grease NLGI #2 or equivalent).
	Use molybdenum disulfide grease (containing more than 3% molybdenum disulfide, NLGI #2 or equivalent) Example: Molykote® BR-2 plus manufactured by Dow Corning, U.S.A. Multi-purpose M-2 manufactured by Mitsubishi Oil Japan
	Use molybdenum disulfide paste (containing more than 40% molybdenum disulfide, NLGI #2 or equivalent) Example: Molykote® G-n Paste manufactured by Dow Corning, U.S.A. Honda Moly 60 Paste (U.S.A. only) Rocol ASP manufactured by Rocol Limited, U.K. Rocol Paste manufactured by Sumico Lubricant, Japan
	Use silicone grease.
	Apply a locking agent. Use Hondalock 2 (U.S.A. only) or an equivalent, unless otherwise specified.
	Apply sealant. Use Hondabond 4 (U.S.A. only) or an equivalent, unless otherwise specified.
	Use DOT 4 Brake Fluid (U.S.A. only) or an equivalent.
	Use Fork or Suspension Fluid. Use Pro Honda Suspension Fluid SS-7M (U.S.A. only) or an equivalent of the type specified.

1. General Information

1

General Safety	1-1	Tools	1-14
Service Rules	1-2	Lubrication & Seal Points	1-16
Model Identification	1-3	Cable & Harness Routing	1-18
Specification	1-4	Optional Parts List	1-21
Torque Values	1-11		

General Safety

Carbon Monoxide

If the engine must be running to do some work, make sure the area is well ventilated. Never run the engine in an enclosed area.

⚠ WARNING

- The exhaust contains poisonous carbon monoxide gas that can cause loss of consciousness and may lead to death.

Run the engine in an open area or with an exhaust evacuation system in an enclosed area.

Gasoline

Work in a well ventilated area. Keep cigarettes, flames or sparks away from the work area or where gasoline is stored.

⚠ WARNING

- Gasoline is extremely flammable and is explosive under certain conditions. **KEEP OUT OF REACH OF CHILDREN.**

Hot Components

⚠ WARNING

- Engine and exhaust system parts become very hot and remain hot for some time after the engine is run. Wear insulated gloves or wait until the engine and exhaust system have cooled before handling these parts.

Used Engine/Transmission Oil

⚠ WARNING

- Used engine oil (or transmission oil in two-strokes) may cause skin cancer if repeatedly left in contact with the skin for prolonged periods. Although this is unlikely unless you handle used oil on a daily basis, it is still advisable to thoroughly wash your hands with soap and water as soon as possible after handling used oil. **KEEP OUT OF REACH OF CHILDREN.**

Brake Dust

Never use an air hose or dry brush to clean brake assemblies. Use an OSHA-approved vacuum cleaner or alternate method approved by OSHA, designed to minimize the hazard caused by airborne asbestos fibers.

⚠ WARNING

- Inhaled asbestos fibers have been found to cause respiratory disease and cancer.

Brake Fluid

CAUTION

- Spilling fluid on painted, plastic or rubber parts will damage them. Place a clean shop towel over these parts whenever the system is serviced. **KEEP OUT OF REACH OF CHILDREN.**

General Information

Coolant

Under some conditions, the ethylene glycol in engine coolant is combustible and its flame is not visible. If the ethylene glycol does ignite, you will not see any flame, but you can be burned.

⚠ WARNING

- Avoid spilling engine coolant on the exhaust system or engine parts. They may be hot enough to cause the coolant to ignite and burn without a visible flame.
- Coolant (ethylene glycol) can cause some skin irritation and is poisonous if swallowed. **KEEP OUT OF REACH OF CHILDREN.**
- Keep out of reach of pets. Some pets are attracted to the smell and taste of coolant and can die if they drink it.
- Do not remove the radiator cap when the engine is hot. The coolant is under pressure and could scald you.

If it contacts your skin, wash the affected areas immediately with soap and water. If it contacts your eyes, flush them thoroughly with fresh water and get immediate medical attention. If it is swallowed, the victim must be forced to vomit then rinse mouth and throat with fresh water before obtaining medical attention. Because of these dangers, always store coolant in a safe place, away from the reach of children.

Recycle used coolant in an ecologically correct manner.

Nitrogen Pressure

For shock absorbers with a gas-filled reservoir:

⚠ WARNING

- Use only nitrogen to pressurize the shock absorber. The use of an unstable gas can cause a fire or explosion resulting in serious injury.
- The shock absorber contains nitrogen under high pressure. Allowing fire or heat near the shock absorber could lead to an explosion that could result in serious injury.
- Failure to release the pressure from a shock absorber before disposing of it may lead to a possible explosion and serious injury if it is heated or pierced.

To prevent the possibility of an explosion, release the nitrogen by pressing the valve core. Then remove the valve stem from the shock absorber reservoir. Dispose of the oil in a manner acceptable to the Environmental Protection Agency (EPA).

Before disposal of the shock absorber, release the nitrogen by pressing the valve core. Then remove the valve stem from the shock absorber.

Service Rules

1. Use genuine HONDA or HONDA-recommended parts and lubricants or their equivalent. Parts that do not meet HONDA's design specifications may damage the motorcycle.
2. Use the special tools designed for this product.
3. Install new gaskets, O-rings, cotter pins, lock plates, etc. when reassembling.
4. When torquing bolts or nuts, begin with larger-diameter or inner bolt first, and tighten to the specified torque, diagonally, in incremental steps unless a particular sequence is specified.
5. Clean parts in non-flammable or high flash point solvent upon disassembly. Lubricate ant sliding surfaces before reassembly.
6. When installing a new oil seal, make sure that the sealing lip is lubricated with grease. If an oil seal and related parts have been washed, apply proper grease to the lip of the oil seal.
7. After reassembly, check all parts for proper installation and operation.
8. Use only metric tools when servicing this motorcycle. Metric bolts, nuts, and screws are not interchangeable with any other type of fasteners. The use of incorrect tools and fasteners may damage the motorcycle.

Model Identification



(1) FRAME SERIAL NUMBER

(1) The frame serial number is stamped on the right side of the steering head.

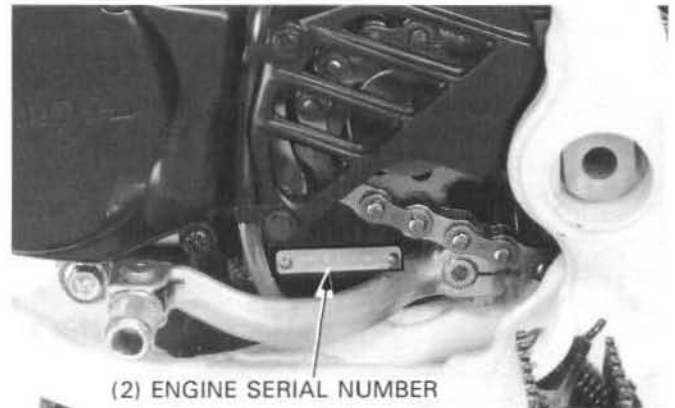

(2) ENGINE SERIAL NUMBER

(2) The engine serial number is stamped on the lower left side of the crankcase.

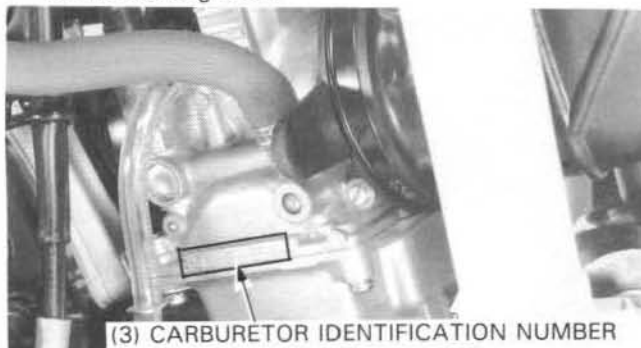

(3) CARBURETOR IDENTIFICATION NUMBER

(3) The carburetor identification number is on the left side of the carburetor body.

Specifications

General		
	Item	Specifications
Dimensions	Overall length	2,128 mm (83.8 in)
	Overall width	825 mm (32.5 in)
	Overall height	1,257 mm (49.5 in)
	Wheelbase	1,442 mm (56.8 in)
	Seat height	980 mm (38.6 in)
	Footpeg height	457 mm (18.0 in)
	Ground clearance	368 mm (14.5 in)
	Dry weight	87.0 kg (191.8 lbs)
Frame	Type	Semi-double cradle
	Front suspension	Telescopic
	Front wheel travel	309 mm (12.2 in)
	Rear suspension	Swingarm/Pro-Link
	Rear wheel travel	320 mm (12.6 in)
	Rear damper	Decarbon type with nitrogen filled reservoir
	Front tire size	80/100-21 51M
	Rear tire size	110/100-18 59M
	Tire brand (Dunlop)	Front Rear K990 K990
	Front brake	Hydraulic single disc
	Front brake swept area	306 cm ² (47.4 in ²)
	Rear brake	Hydraulic single disc
	Rear brake swept area	303 cm ² (47.0 in ²)
	Caster angle	26°00'
	Trail length	108 mm (4.3 in)
Fuel tank capacity	7.5 liters (2.0 US gal, 1.6 Imp gal)	
Engine	Bore and stroke	54 x 54.5 mm (2.1 x 2.1 in)
	Displacement	124.82 cm ³ (7.6 cu-in)
	Compression ratio	9.1 : 1
	Lubrication system	Fuel/oil mix
	Cooling system	Liquid cooled
	Air filtration	Oiled polyurethane foam
	Crankshaft type	Assembled type
	Engine dry weight	17.6 kg (38.8 lbs)
	Cylinder arrangement	Single cylinder 18.5° inclined from vertical

General (Cont'd)		
	Item	Specifications
Carburetor	Carburetor type Venturi diameter	Piston valve 36 mm (1.4 in)
Drive Train	Clutch system Clutch operation system Transmission Primary reduction Final reduction Gear ratio 1st Gear ratio 2nd Gear ratio 3rd Gear ratio 4th Gear ratio 5th Gear ratio 6th Gearshift pattern	Wet, multi-plate type Wire operated 6 speeds constant mesh 3.150 : 1 (63/20) 3.923 : 1 (51/13) 2.357 : 1 (33/14) 1.867 : 1 (28/15) 1.526 : 1 (28/19) 1.285 : 1 (27/21) 1.130 : 1 (25/23) 1.000 : 1 (24/24) Left foot-operated return system 1-N-2-3-4-5-6
Electrical	Ignition system	CDI

General Information

Unit: mm (in)

Lubrication	Item	Standard	Service Limit
Recommended engine oil Fuel/oil mixing ratio Transmission oil capacity at draining at disassembly Recommended transmission oil		Honda HP-2 2-Stroke Oil or equivalent	—
		32 : 1	—
		0.57 liter (0.60 US qt, 0.50 Imp qt)	—
		0.65 liter (0.69 US qt, 0.57 Imp qt)	—
	Use Honda GN4 4-Stroke Oil or equivalent	—	
	API Service Classification: SF or SG		
	Viscosity: SAE 10W-40		
	Other viscosities shown in the chart may be used when the average temperature in your riding area is within the indicated range.		

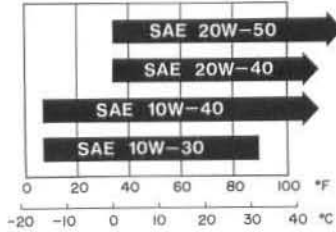

Fuel System	Item	Standard	Service Limit
Carburetor identification number Main jet (Standard) Slow jet (Standard) Jet needle clip position (Standard) Air screw initial opening Float level Throttle grip free play		PJ15E	—
		# 172	—
		# 58	—
		3rd groove	—
		2 turns out	—
		16.0 (0.63)	—
		3-5 (1/8-1/4)	—

Cooling System	Item	Standard	Service Limit
Recommended coolant Coolant capacity Radiator cap relief pressure		Use only a high quality ethylene glycol based anti-freeze containing corrosion inhibitors specifically recommended for use in aluminum engines. A 50/50 mixture of anti-freeze and distilled water is recommended for most operating conditions. (See anti-freeze container label for other mixture ratios.)	—
		750 cc (25.4 US oz, 26.3 Imp oz)	—
		110-140 kPa	—
		(1.1-1.4 kg/cm ² , 16-20 psi)	—

Clutch System	Item	Standard	Service Limit
Clutch lever free play Clutch spring free length Clutch disc thickness Clutch plate warpage		10-20 (3/8-3/4)	—
		39.4 (1.55)	37.5 (1.48)
		2.92-3.08 (0.114-0.121)	2.85 (0.112)
		—	0.15 (0.006)

Unit: mm (in)

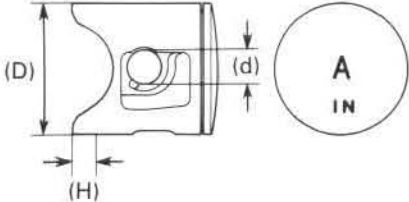
Cylinder Head/Cylinder/Piston	Item	Standard	Service Limit
	Cylinder head warpage	—	0.05 (0.002)
	Cylinder I.D. A	53.976—53.983 (2.1250—2.1253)	54.513 (2.1265)
	B	53.968—53.976 (2.1247—2.1250)	54.006 (2.1262)
	out of round	—	0.05 (0.002)
	taper	—	0.05 (0.002)
	warpage	—	0.05 (0.002)
	Piston mark direction	"IN" mark toward the intake side	—
	Piston O.D. (D) A	53.933—53.940 (2.1233—2.1236)	53.883 (2.1214)
	B	53.925—53.933 (2.1230—2.1233)	53.875 (2.1211)
	Piston O.D. measurement point (H)	20 mm (0.79 in) from the bottom	—
	Piston pin bore (d)	15.002—15.008 (0.5906—0.5909)	15.022 (0.5914)
			
	Cylinder-to-piston clearance	0.035—0.050 (0.0014—0.0020)	0.07 (0.003)
	Piston pin O.D.	14.994—15.000 (0.5903—0.5906)	14.980 (0.5898)
	Piston-to-piston pin clearance	0.002—0.014 (0.0001—0.0006)	0.02 (0.001)
	Piston ring-to-ring groove clearance	0.045—0.080 (0.0018—0.0031)	0.09 (0.004)
	Piston ring end gap	0.40—0.55 (0.016—0.022)	0.65 (0.026)
	Piston ring mark direction	Mark facing up	—

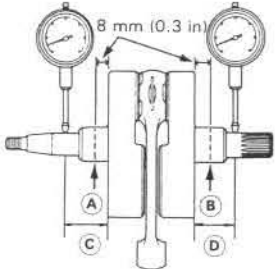
Crankshaft	Item	Standard	Service Limit
	Connecting rod small end I.D.	19.002—19.014 (0.7481—0.7486)	19.022 (0.7489)
	Connecting rod big end side clearance	0.4—0.8 (0.02—0.03)	0.9 (0.04)
	radial play	0.022—0.034 (0.0009—0.0013)	0.044 (0.0017)
	Crankshaft runout	—	0.05 (0.002)
			

Kickstarter	Item	Standard	Service Limit
	Kickstarter pinion gear I.D.	16.516—16.534 (0.6502—0.6509)	16.550 (0.6516)
	Kickstarter spindle O.D.	16.466—16.484 (0.6483—0.6490)	16.450 (0.6476)
	Kickstarter idle gear	17.016—17.034 (0.6699—0.6706)	17.050 (0.6713)
	Countershaft O.D. at kickstarter idle gear	16.983—16.994 (0.6686—0.6691)	16.970 (0.6681)

General Information

Unit: mm (in)

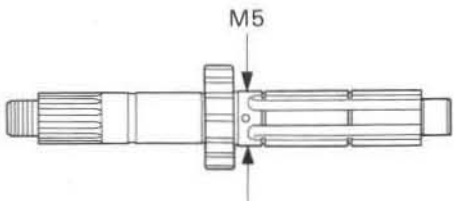
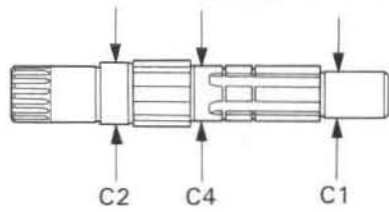
Transmission		Standard	Service Limit
Item			
Transmission gear I.D.	M5, M6 C1	23.020–23.041 (0.9063–0.9071) 20.020–20.041 (0.9063–0.9071)	23.060 (0.9080) 20.060 (0.7900)
Transmission gear bushing O.D.	M5, M6 C1	25.020–25.041 (0.9850–0.9859) 22.959–22.980 (0.9039–0.9047)	25.060 (0.9870) 22.940 (0.9030)
Transmission gear bushing I.D.	M5, M6 C1	24.979–25.000 (0.7866–0.7874) 20.000–20.021 (0.7874–0.7782)	24.950 (0.7850) 20.040 (0.7890)
Gear-to-bushing clearance	M5, M6 C1	22.000–22.021 (0.8661–0.8670) 0.040–0.082 (0.0016–0.0032)	22.040 (0.8680) 0.120 (0.0047)
Mainshaft O.D. at M5 gear	M5, M6 C1	0.020–0.062 (0.0008–0.0024) 0.020–0.062 (0.0008–0.0024)	0.110 (0.0043) 0.110 (0.0043)
	C2, C4	0.020–0.062 (0.0008–0.0024)	0.110 (0.0043)
		19.959–19.980 (0.7858–0.7866)	19.940 (0.7850)
			
Countershaft O.D. at C2, C4 bushing		21.959–21.980 (0.8645–0.8654)	21.940 (0.8638)
at C1 bushing/starter idle gear		16.983–16.994 (0.6686–0.6691)	16.970 (0.6681)
			
Gear bushing-to-shaft clearance	M5	0.020–0.062 (0.0008–0.0024)	0.100 (0.0039)
	C1	0.006–0.035 (0.0002–0.0014)	0.060 (0.0024)
	C2, C4	0.020–0.062 (0.0008–0.0024)	0.100 (0.0039)
Shift fork claw thickness		4.93–5.00 (0.194–0.197)	4.8 (0.19)
Shift fork I.D.		11.041–11.056 (0.4347–0.4353)	11.065 (0.4356)
Shift fork shaft O.D.		10.983–10.944 (0.4324–0.4308)	10.973 (0.4320)

Unit: mm (in)

Wheels/Tires		Standard	Service Limit
Item			
Cold tire pressure		100 kPa (1.0 kg/cm ² , 15 psi)	—
Front and rear axle runout		100 kPa (1.0 kg/cm ² , 15 psi)	—
Front and rear wheel rim runout	(Radial)	—	0.20 (0.008)
	(Axial)	—	2.0 (0.08)
Front wheel hub-to-rim distance		20.00 (0.787)	—
Front wheel hub standard surface		(See page 11–6)	—
Rear wheel hub-to-rim distance		47.25 (1.860)	—
Rear wheel hub standard surface		(See page 12–5)	—
Drive chain slack		35–40 (1-3/8–1-9/16)	—
Drive chain size/link (DID)		520DS6-114	—
	(RK)	RK520TZ2X-114RJ	—
Drive chain tensioner roller O.D.		—	25 (0.98)
Drive chain slider thickness		—	5 (0.2)

Front Suspension		Standard	Service Limit
Fork spring free length (Standard)		512.0 (20.16)	504.5 (19.86)
Fork spring direction		With the tapered end facing up	—
Fork tube runout		—	0.2 (0.01)
Recommended fork oil		Pro Honda Suspension Fluid SS-7M or equivalent	—
Fork oil level	(Standard)	106 (4.2)	—
	(Adjustable range: Max.)	92 (3.6)	—
	(Adjustable range: Min.)	123 (4.8)	—
Fork oil capacity	(Standard)	571 cc (19.31 US oz, 20.04 Imp oz)	—
	(Adjustable range: Max.)	585 cc (19.78 US oz, 20.53 Imp oz)	—
	(Adjustable range: Min.)	553 cc (18.70 US oz, 19.41 Imp oz)	—
Fork air pressure	(Standard)	0 kg/cm ²	—
Compression damping adjuster standard position		5 clicks out from full in	—
Rebound damping adjuster standard position		12 clicks out from full in	—

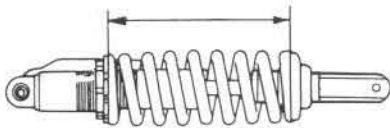
Rear Suspension		Standard	Service Limit
Shock absorber spring free length		265 (10.4)	262 (10.3)
Damper gas pressure		981 kPa (10.0 kg/cm ² , 142 psi)	—
Damper compressed gas		Nitrogen gas	—
Damper rod compressed force at 10 mm compressed		13.4–17.4 kg (29.54–38.36 lbs)	13.4 kg (29.54 lbs)
Shock absorber spring installed length (Standard)		255.0 (10.04)	—
	(Adjustable range: Max.)	260.5 (10.26)	—
	(Adjustable range: Min.)	244.5 (9.63)	—
			
Shock absorber spring direction		Narrow end facing down	—
Recommended shock absorber oil		Pro Honda Suspension Fluid SS-7 or equivalent	—
Shock oil capacity		290 cc (9.81 US oz, 10.35 Imp oz)	—
Compression damping adjuster standard position		7–10 clicks out from full in	—
Rebound damping adjuster standard position		8–11 clicks out from full in	—

General Information

Unit: mm (in)

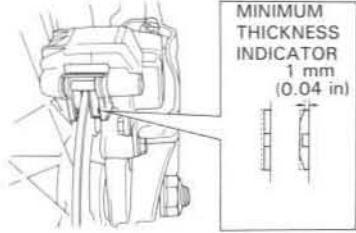
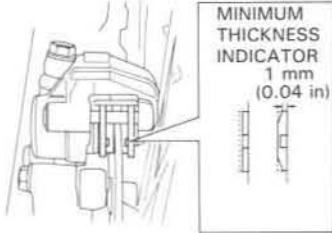
Brakes		Standard	Service Limit
Front	brake fluid brake pad wear indicator 	DOT 4	1.0 (0.04)
	brake disc thickness	3.0 (0.12)	2.5 (0.10)
	brake disc runout	—	0.15 (0.006)
	master cylinder I.D.	11.000–11.043 (0.4330–0.4347)	11.05 (0.435)
	master piston O.D.	10.957–10.984 (0.4314–0.4324)	10.84 (0.427)
	caliper cylinder I.D.	27.000–27.050 (1.0630–1.0650)	27.06 (1.065)
	caliper piston O.D.	26.900–26.950 (1.0590–1.0610)	26.89 (1.059)
Rear	brake fluid brake pad wear indicator 	DOT 4	1.0 (0.04)
	brake disc thickness	4.5 (0.18)	4.0 (0.16)
	brake disc runout	—	0.15 (0.006)
	master cylinder I.D.	12.700–12.743 (0.4999–0.5016)	12.76 (0.502)
	master piston O.D.	12.657–12.684 (0.4983–0.4993)	12.64 (0.498)
	caliper cylinder I.D.	27.000–27.050 (1.0630–1.0650)	27.06 (1.065)
	caliper piston O.D.	26.935–26.968 (1.0604–1.0617)	26.89 (1.059)

Ignition System			
Spark plug	(Standard: CHAMPION) (Standard: NGK) (Standard: NIPPONDENSO) (Optional: CHAMPION) (Optional: NGK) (Optional: NIPPONDENSO)	QN84 BR9EG W27ESR-V QN59G BR9EV W27ESR-G	— — — — — —
Spark plug gap		0.5–0.6 (0.020–0.024)	—
Ignition timing "F" mark		30 ± 2°/5,000 rpm	—
Ignition coil resistance	(Primary: at 20°C/68°F) (Secondary with plug cap) (Secondary without plug cap)	0.4–0.6 Ω 14–23 kΩ 10–16 kΩ	— — —
Alternator exciter coil resistance	(At 20°C/68°F)	20–140 Ω	—
Pulse generator resistance	(At 20°C/68°F)	180–280 Ω	—

Torque Values

Standard			
Fasteners Type	Torque N·m (kg-m, ft-lb)	Fasteners Type	Torque N·m (kg-m, ft-lb)
5 mm hex bolt and nut	5 (0.5, 3.6)	5 mm screw	4 (0.4, 2.9)
6 mm hex bolt and nut	10 (1.0, 7)	6 mm screw	9 (0.9, 6.5)
8 mm hex bolt and nut	22 (2.2, 16)	6 mm flange bolt (8 mm head)	9 (0.9, 6.5)
10 mm hex bolt and nut	35 (3.5, 25)	6 mm flange bolt (10 mm head) and nut	12 (1.2, 9)
12 mm hex bolt and nut	55 (5.5, 40)	8 mm flange bolt and nut	27 (2.7, 20)
		10 mm flange bolt and nut	40 (4.0, 29)

Torque specifications listed below are for important fasteners. Others should be tightened to the standard torque values listed above.

- Notes: 1. Apply a locking agent to the threads.
 2. Stake.
 3. U-nut.
 4. UBS nut.

Engine				
Item	Thread dia. and pitch (mm)	Torque N·m (kg-m, ft-lb)	Remarks	
Maintenance:				
Oil drain bolt	12 x 1.5	30 (3.0, 22)		
Oil check bolt	6 x 1.0	10 (1.0, 7)		
Cooling System:				
Radiator hose clamp	—	0.8 (0.08, 0.6)		
Water pump cover bolt	6 x 1.0	12 (1.2, 9)		
Water pump impeller	7 x 1.0	12 (1.2, 9)		
Coolant drain bolt	6 x 1.0	10 (1.0, 7)		
Fuel System:				
Carburetor insulator	6 x 1.0	12 (1.2, 9)		
Cylinder Head/Cylinder/H.P.P.:				
Cylinder head nut	8 x 1.25	27 (2.7, 20)	Note 1	
Cylinder mounting nut	8 x 1.25	27 (2.7, 20)		
Cylinder stud bolt	8 x 1.25	12 (1.2, 9)		
H.P.P. valve guide bolt	6 x 1.0	9 (0.9, 6.5)		
H.P.P. pinion holder socket bolt	5 x 0.8	5.5 (0.55, 4.0)		
H.P.P. valve drive shaft nut	6 x 1.0	10 (1.0, 7)		
H.P.P. valve cover bolt	6 x 1.0	12 (1.2, 9)		
H.P.P. valve cover screw	5 x 1.0	2.5 (0.25, 1.8)		
H.P.P. drain bolt	6 x 1.0	10 (1.0, 7)		
H.P.P. pinion rod setting screw	6 x 1.0	9 (0.9, 6.5)		
Cylinder upper cover bolt	6 x 1.0	12 (1.2, 9)		
Clutch/Kickstarter/Gearshift Linkage:				
Clutch center lock nut	18 x 1.0	60 (6.0, 4.3)		
Clutch spring bolt	6 x 1.0	10 (1.0, 7)		
Primary drive gear bolt	10 x 1.25	45 (4.5, 33)		
Gearshift drum center pin	8 x 1.25	22 (2.2, 16)		
Right crankcase/clutch cover bolt	6 x 1.0	10 (1.0, 7)		
Gearshift drum stopper arm bolt	6 x 1.0	12 (1.2, 9)		
Gearshift pedal pinch bolt	6 x 1.0	12 (1.2, 9)		
Kickstarter pedal bolt	8 x 1.25	27 (2.7, 20)	Note 1	

General Information

Engine (Cont'd)			
Item	Thread dia. and pitch (mm)	Torque N·m (kg-m, ft-lb)	Remarks
Crankshaft/Transmission:			
Drive sprocket bolt	8 x 1.25	27 (2.7, 20)	
Countershaft bearing set plate screw	6 x 1.0	10 (1.0, 7)	Note 1
Gearshift drum bearing set plate screw	6 x 1.0	10 (1.0, 7)	Note 1
Alternator:			
Flywheel nut	12 x 1.25	55 (5.5, 40)	
Alternator cover screw	6 x 1.0	4 (0.4, 2.9)	

Frame			
Item	Thread dia. and pitch (mm)	Torque N·m (kg-m, ft-lb)	Remarks
Frame Body Panels/Exhaust System:			
Seat mounting bolt	8 x 1.25	22 (2.2, 16)	
Sub-frame mounting bolt	8 x 1.25	27 (2.7, 20)	
Drive chain guide bolt	6 x 1.0	12 (1.2, 9)	
Maintenance:			
Chain tensioner roller	8 x 1.25	22 (2.2, 16)	Note 3
Wheel/Tires:			
Front axle holder bolt	8 x 1.25	20 (2.0, 14)	
Front axle nut	14 x 1.5	87 (8.7, 63)	
Rear axle nut	18 x 1.5	95 (9.5, 69)	Note 3
Front/rear spoke nipple	BC3.5/BC4.0	3.8 (0.38, 2.8)	
Front/rear rim lock	8 x 1.25	13 (1.3, 9.5)	
Front Suspension:			
Steering stem nut	24 x 1.5	118 (11.8, 85)	
Steering stem adjusting nut	26 x 1.5	2 (0.2, 1.4)	
Fork tube pinch bolt (Top)	8 x 1.25	22 (2.2, 16)	
(Bottom)	8 x 1.25	22 (2.2, 16)	
Fork cap	48 x 1.5	35 (3.5, 25)	
Fork cap lock nut	12 x 1.0	22 (2.2, 16)	
Fork center bolt	27 x 1.0	80 (8.0, 58)	
Fork protector mounting bolt	6 x 1.0	13 (1.3, 9.5)	Note 1
Brake lever pivot nut	6 x 1.0	6 (0.6, 4.3)	
Clutch lever pivot bolt	6 x 1.0	2 (0.2, 1.5)	
Clutch lever pivot lock nut	6 x 1.0	10 (1.0, 7)	
Clutch lever holder bolt	6 x 1.0	10 (1.0, 7)	
Throttle housing bolt	6 x 1.0	10 (1.0, 7)	
Throttle housing case screw	4 x 0.7	1.5 (0.15, 1.1)	
Engine stop switch screw	4 x 0.7	1.5 (0.15, 1.1)	
Handlebar upper holder bolt	8 x 1.25	22 (2.2, 16)	
Rear Suspension:			
Swingarm pivot nut	16 x 1.5	90 (9.0, 65)	Note 3
Shock arm (Swingarm side)	12 x 1.25	63 (6.3, 46)	Note 3
(Shock link side)	12 x 1.25	63 (6.3, 46)	Note 3
Shock link (frame side)	12 x 1.25	63 (6.3, 46)	Note 3
Shock absorber mounting bolt (Upper)	10 x 1.25	45 (4.5, 33)	
(Lower)	10 x 1.25	43 (4.3, 31)	
Shock absorber damper rod end nut	12 x 1.5	27 (2.7, 20)	Note 2
Shock absorber damping adjuster	24 x 1.0	20 (2.0, 14)	Note 2
Shock absorber spring lock nut	56 x 1.5	90 (9.0, 65)	
Final driven sprocket nut	8 x 1.25	30 (3.0, 24)	Note 3

Frame (Cont'd)			
Item	Thread dia. and pitch (mm)	Torque N·m (kg-m, lb-ft)	Remarks
Brake System:			
Front brake disc mounting bolt	6 x 1.0	20 (2.0, 14)	Note 1
Rear brake disc mounting bolt	8 x 1.25	43 (4.3, 31)	Note 1
Brake hose bolt	10 x 1.25	35 (3.5, 25)	
Brake caliper bleeder valve	8 x 1.25	6 (0.6, 4.3)	
Brake hose guide	6 x 1.0	5 (0.5, 3.6)	Note 1
Brake lever adjuster lock nut	5 x 0.5	6 (0.6, 4.3)	
Rear disc guard mounting screw	6 x 1.0	7 (0.7, 5.1)	Note 1
Front brake caliper mounting bolt	8 x 1.25	31 (3.1, 22)	Note 1
Brake caliper pad pin	10 x 1.0	18 (1.8, 13)	
Brake caliper pad pin plug	10 x 1.0	2.5 (0.25, 1.8)	
Brake caliper pin bolt	8 x 1.25	13 (1.3, 9)	Note 1
Brake caliper pin bolt A (Front)	8 x 1.25	23 (2.3, 17)	Note 1
(Rear)	12 x 1.25	28 (2.8, 20)	Note 1
Rear brake master cylinder mounting bolt	6 x 1.0	15 (1.5, 11)	Note 1
Front master cylinder holder bolt	6 x 1.0	10 (1.0, 7)	
Brake pedal pivot bolt	8 x 1.25	26 (2.6, 19)	
Engine Mounting:			
Engine mounting bolt	8 x 1.25	27 (2.7, 20)	
Engine hanger plate bolt	8 x 1.25	27 (2.7, 20)	

Tools

The newly designed tools are indicated with * mark in the list.

Special	Description	Tool Number	Applicability
	Maintenance:		
	Spoke nipple wrench	07JMA-MR60100	or equivalent commercially available in U.S.A.
	Cooling System:		
	Water seal driver	07945-KA30000	GN-AH-065-415 (U.S.A. only)
	Bearing remover set, 12 mm	07936-1660001	Not available in U.S.A.
	- remover handle assembly	07936-1660101	
	- remover weight	07741-0010201	or 07936-3710200
	Bearing remover, 7 mm	07931-KA30000	
	Bearing driver, 7 mm	07946-KA30000	
	H.P.P.:		
	Bearing remover, 7 mm	07931-KA30000	
	Bearing driver, 7 mm	07946-KA30000	
	Crankshaft/Transmission:		
	Crankcase puller	07937-4300000	
	Universal bearing puller	07631-0010000	
	Crankcase assembly tool set	07965-1660101	
	- assembly tool shaft	07965-1660200	
	- assembly collar	07965-1660301	
	Bearing remover, 17 mm	07936-3710300	or equivalent commercially available in U.S.A.
	- remover handle	07936-3710100	
	- remover weight	07741-0010201	or 07936-3710200
	Thread adaptor	07965-KA30000	
	Front Suspension/Steering:		
	Bearing race remover	07953-4250002	or 07953-MJ1000A
	Steering stem socket	07916-KA50100	
	Oil seal driver	07KMD-KZ30100	
	* Oil seal driver attachment	07NMD-KZ30100	
	Fork slider spacer	07KMZ-KZ30101	
	Ball race remover	07948-4630100	
	Steering stem driver	07946-MB00000	
	Rear Wheel/Suspension:		
	Needle bearing driver	07946-KA50000	
	Spherical bearing driver	07HMF-KS60100	
	Slider guide, 14 mm	07974-KA40001	
	Slider guide attachment	07974-KA50101	
	Sleeve collar	07974-KA30201	
	Driver head	07946-KM40701	
	Driver shaft	07946-MJ00100	
	Attachment, 28 x 30 mm	07946-1870100	
	Brake System:		
	Snap ring pliers	07914-3230001	

Common		
Description	Tool Number	Applicability
Fuel System:		
Float level gauge	07401-0010000	
Cooling System:		
Driver	07749-0010000	
Attachment, 24 x 26 mm	07746-0010700	
Pilot, 12 mm	07746-0040200	
H.P.P.:		
Driver	07749-0010000	
Attachment, 24 x 26 mm	07746-0010700	
Clutch/Kickstarter/Gearshift Linkage:		
Clutch center holder	07724-0050001	
Crankshaft/Transmission:		
Universal holder	07725-0030000	
Driver	07746-0010000	
Attachment, 32 x 35 mm	07746-0010100	
Attachment, 37 x 40 mm	07746-0010200	
Attachment, 42 x 47 mm	07746-0010300	
Attachment, 52 x 55 mm	07746-0010400	
Pilot, 17 mm	07746-0040400	
Pilot, 20 mm	07746-0040500	
Pilot, 22 mm	07746-0041000	
Pilot, 25 mm	07746-0040600	
Wheels/Tires:		
Retainer wrench body	07710-0010401	
Bearing retainer wrench B	07710-0010200	
Bearing remover head, 17 mm	07746-0050500	
Bearing remover shaft	07746-0050100	
Bearing remover head, 20 mm	07746-0050600	
Attachment, 32 x 35 mm	07746-0010100	
Attachment, 42 x 47 mm	07746-0010300	
Pilot, 17 mm	07746-0040400	
Pilot, 20 mm	07746-0040500	
Front Suspension/Steering:		
Driver	07749-0010000	
Attachment, 42 x 47 mm	07746-0010300	
Attachment, 52 x 55 mm	07746-0010400	
Rear Wheel/Suspension:		
Driver	07749-0010000	
Attachment, 24 x 26 mm	07746-0010700	
Attachment, 32 x 35 mm	07746-0010100	
Pilot, 20 mm	07746-0040500	
Pilot, 22 mm	07746-0041000	
Ignition System/Alternator:		
Universal holder	07725-0030000	
Flywheel puller	07733-0010000	or 07933-0010000
Electrical Equipment:		
Digital multimeter (KOWA)	07411-0020000	
Analogue tester	07308-0020001 (SANWA or TH-5H (KOWA))	

Optional		
Description	Tool Number	Applicability
Pin spanner A	89201-KS6-810	2 piece

Lubrication & Seal Points

Engine	Location	Material	Remarks
	Connecting rod big end small end needle bearing Crankshaft bearing Piston surface Piston pin outer surface Piston ring groove H.P.P. exhaust valve surface	Honda HP2 2-Stroke Oil or equivalent	
	Transmission gear Mainshaft/countershaft Kickstarter spindle spline Kickstarter spindle gear sliding surface Governor steel balls H.P.P. valve pinion sliding surface H.P.P. valve drive shaft sliding surface H.P.P. valve lever and pinion sliding surface H.P.P. valve cylinder head upper cover surface Water pump gear teeth	Molybdenum disulfide oil	
	Each bearings Governor bearing Governor shaft sliding surface	Honda GN4 4-Stroke Oil or equivalent	
	Oil seal lips Water seal lips	Multi-purpose grease	
	Cylinder stud bolt thread Kickstarter pedal bolt thread Countershaft bearing set plate screw Gearshift drum bearing set plate screw	Honda Anaerobic Thread Lock or equivalent	

Frame	Location	Material	Remarks
	Throttle cable end Throttle grip sliding surface	Honda GN4 4-Stroke Oil or equivalent	
	Steering stem bearing Wheel bearing dust seal lips Wheel axle and swingarm pivot outer surface Handlebar (throttle grip sliding surface) Rear shock absorber spherical bearing Suspension linkage bearings Swingarm bearings Brake pedal pivot sliding surface Dust seal lips	Multi-purpose grease	Apply thin coat of grease
	Brake lever pivot bolt sliding surface Brake lever adjusting bolt	Silicone grease	
	Fork protector mounting bolt Front brake caliper mounting bolt Brake disc mounting bolt Rear brake hose guide screw Rear brake disc guard mounting screw Brake caliper pin bolt Brake caliper pin bolt A Rear brake master cylinder mounting bolt	Honda Anaerobic Thread Lock or equivalent	
	Fork cap O-ring Fork oil seal lips	Pro Honda Suspension Fluid SS-7M or equivalent	
	Handle grip	Honda Hand Grip Cement (U.S.A. Only)	

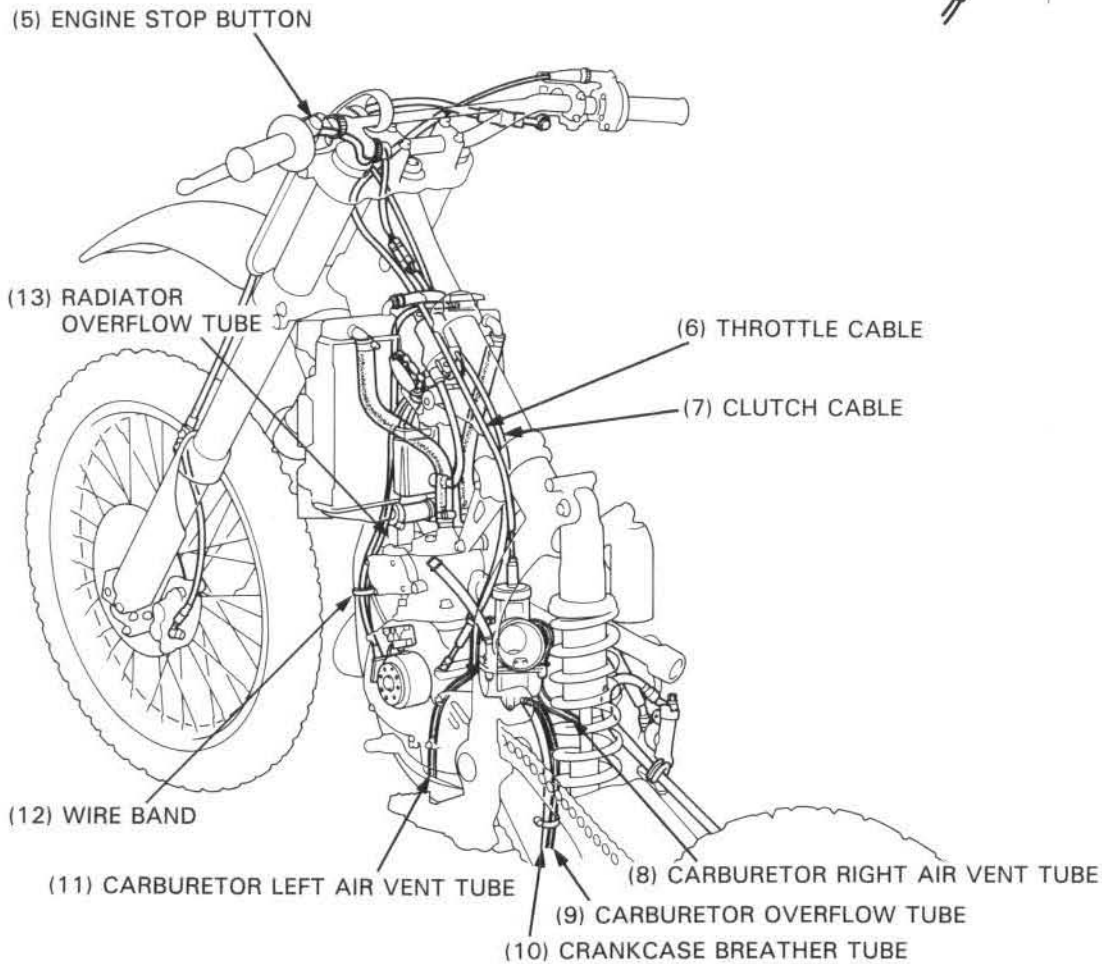
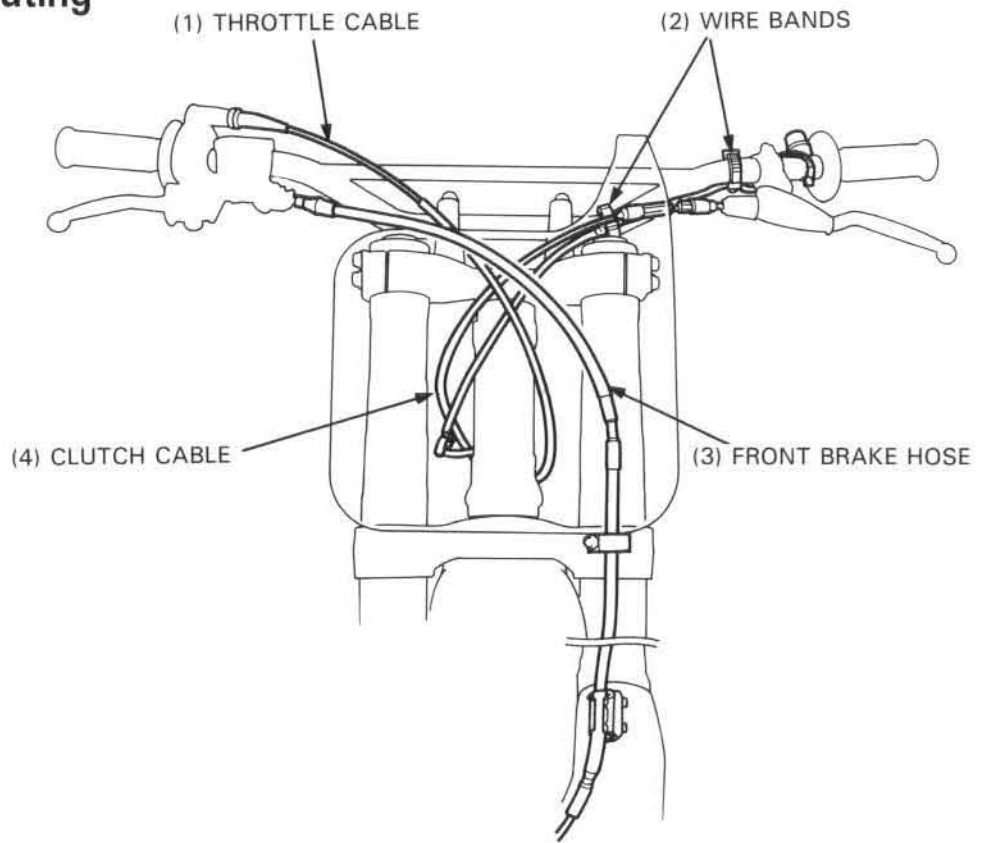

Cable & Harness Routing

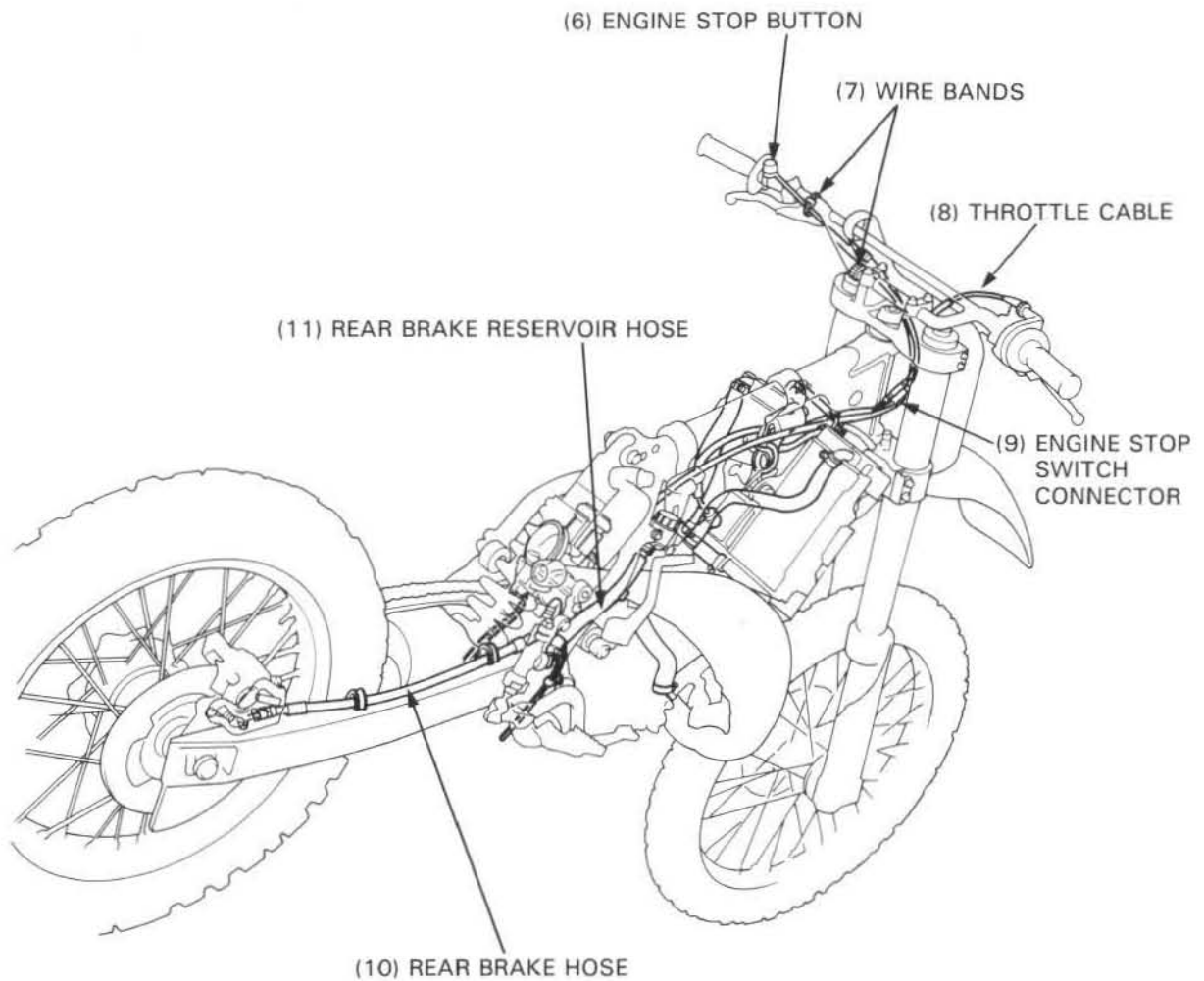
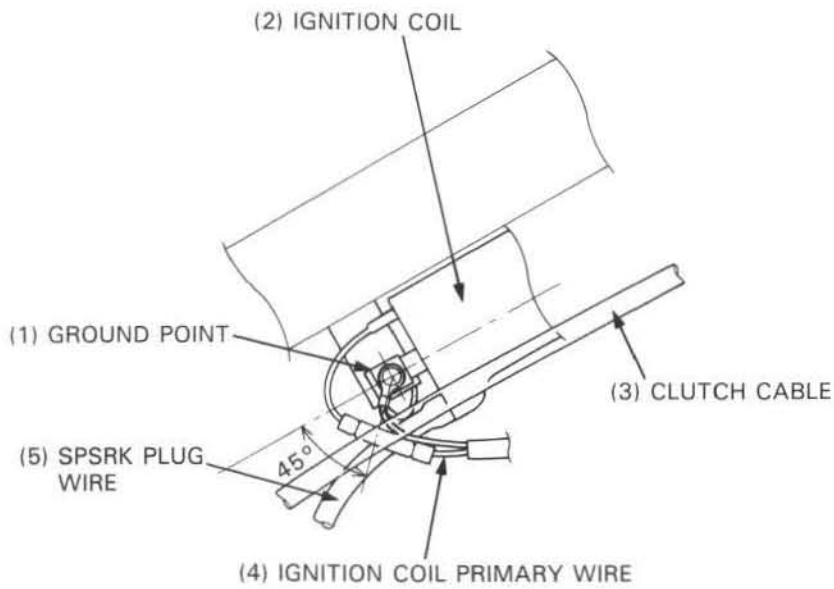

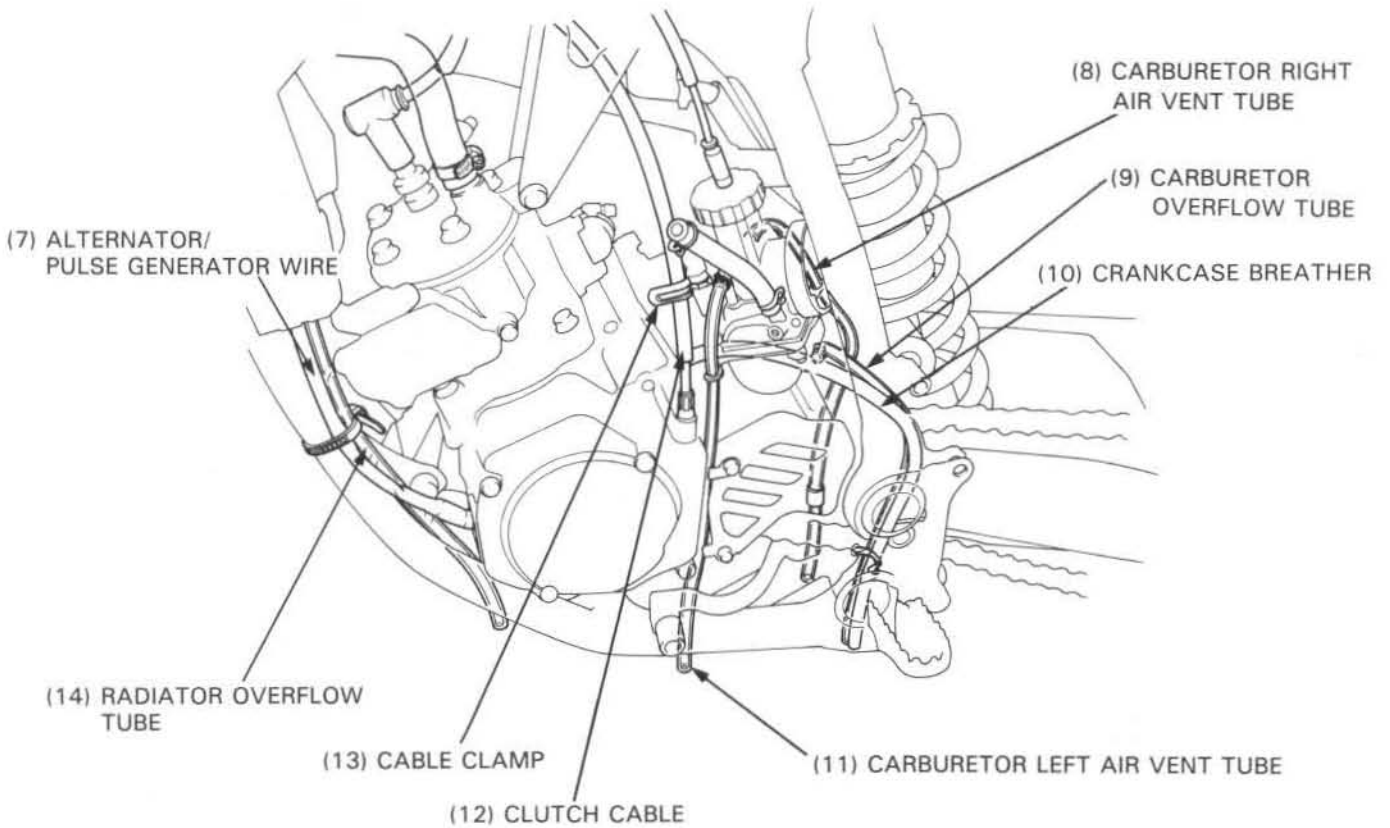
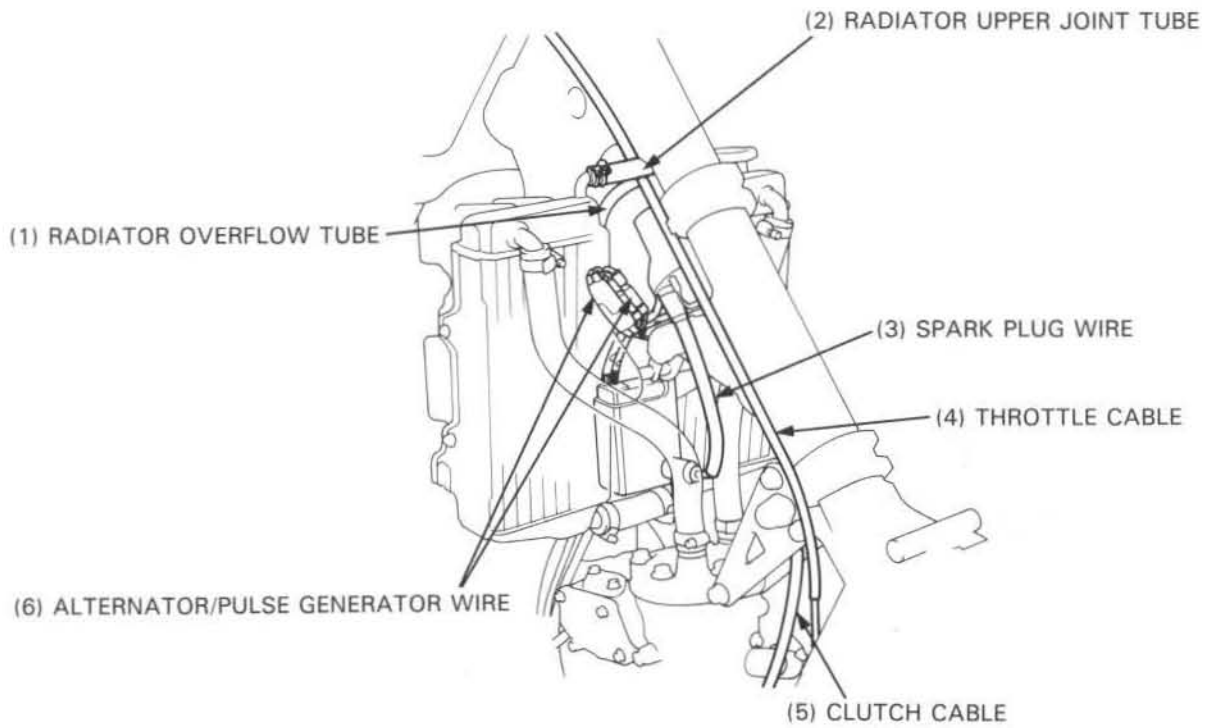



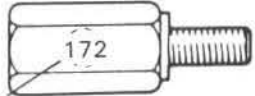
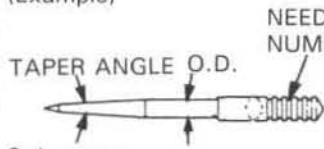



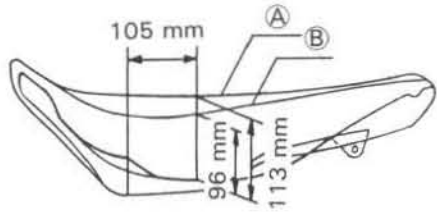

Optional Parts List

Engine		Item	Remarks		
Carburetor:	Main jet	Standard	# 172 # 160— # 185 (in increments of 2 or 3) R1469NS (Ø 2.695—1°45')		
	Jet needle	Optional			
		Standard			
					
General Flow Characteristics		Jet needle number	O.D. (mm)	Taper angle	Specific flow characteristics
Leaner than the standard R1469NS needle		R1470NS	2.705	1°45'	Leaner only at 1/8 to 1/4 throttle.
Richer than the standard R1469NS needle		R1468NS	2.685	1°45'	Richer only at 1/8 to 1/4 throttle.
		Explanation of the jet needle numbers (Example)			
					
					
Jet needle clip standard position					
Slow jet		Standard			
		Optional			
			# 52— # 62 (in increments of 2 or 3)		

Frame		Item	Remarks
Maintenance:	Work stand		Provides support in an upright position
	Air pressure gauge		For checking tire air pressure
	Pin spanner		Pin spanner A x 2
Seat:		Standard	For shock absorber spring installed length (preload) adjustment (two required)
		Optional	Seat A: Seat thickness 113 mm (4.4 in) Seat B: Seat thickness 96 mm (3.8 in)
			
Drive Chain & Sprocket:	Driven sprocket	Standard	51T (Aluminum)
		Optional	49T (Aluminum) 53T (Aluminum)
Drive chain		Standard	51T (Steel; for Muddy or Sandy track conditions)
		Optional	RK 520T22/114RJ DID 520DS6/114 RK 520T22/116RJ DID 520DS6/116

General Information

Frame			
Item	Remarks		
Fork: Spring	Type	Spring Rate	Identification Mark
	Light	0.34 kg/mm (19.04 lb/in)	4 coils 
	Standard	0.36 kg/mm (20.16 lb/in)	3 coils 
	Heavy	0.38 kg/mm (21.28 lb/in)	1 coil 
Rear Shock Absorber: Spring	Type	Spring Rate	Identification Mark
	Light	4.4 kg/mm (246.4 lb/in)	Brown paint 
	Standard	4.8 kg/mm (268.8 lb/in)	White paint 
	Heavy	5.2 kg/mm (291.2 lb/in)	Red paint 

2. Frame/Body Panels/Exhaust System

Service Information	2-1	Fuel Tank	2-3
Troubleshooting	2-1	Exhaust Pipe	2-4
Seat	2-2	Sub-frame	2-5
Side Cover	2-2		

Service Information

General

⚠ WARNING

- Gasoline is extremely flammable and is explosive under certain conditions.
- Serious burns may result if the exhaust system is not allowed to cool before components are removed or serviced.

- Work in a well ventilated area. Smoking or allowing flames or sparks in the working area or where gasoline is stored can cause a fire or explosion.
- This section covers removal and installation of the frame body panels, fuel tank and exhaust system.
- Always replace the exhaust chamber gasket when removing the exhaust chamber from the engine.
- Always inspect the exhaust system for leaks after installation.

Torque Values

Seat mounting bolt	22 N•m (2.2 kg-m, 16 ft-lb)
Sub-frame mounting bolt	27 N•m (2.7 kg-m, 20 ft-lb)

Troubleshooting

Excessive Exhaust Noise

- Broken exhaust system
- Exhaust gas leak
- Worn silencer glass wool packing

Poor Performance

- Deformed exhaust system
- Exhaust gas leak
- Clogged chamber/silencer

Seat

Removal

Remove the two mounting bolts and seat.

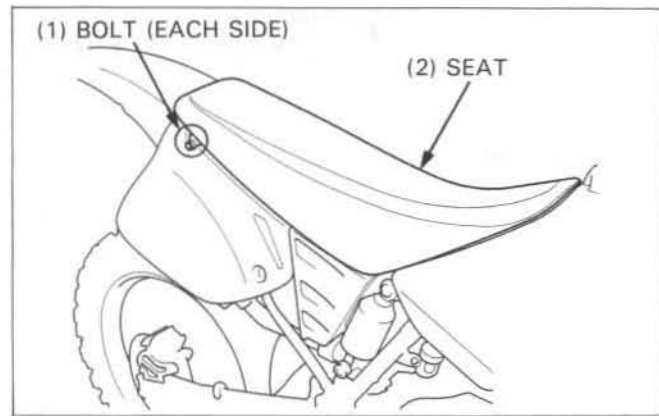

Installation

Align the hook of the seat with the mounting screw on the fuel tank.

Also align the seat side prongs with the sub-frame tabs.

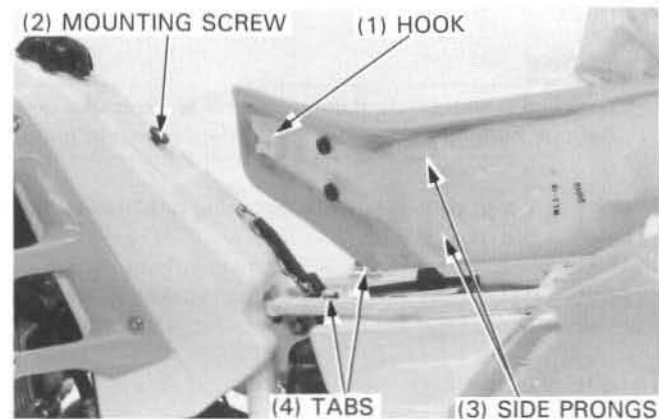

Install and tighten the seat mounting bolts.

Torque: 22 N·m (2.2 kg-m, 16 ft-lb)

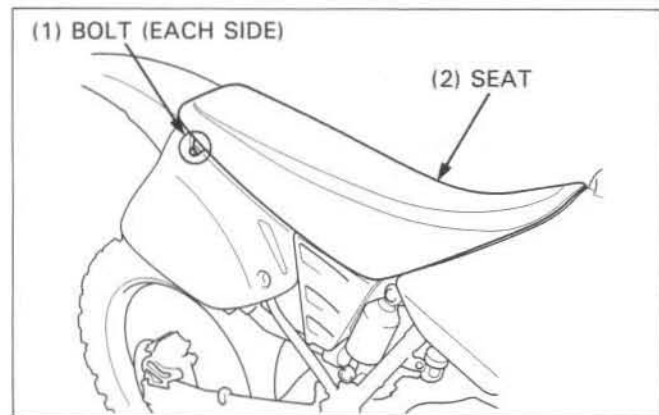

Side Covers

Removal/Installation

Remove the seat.

Remove the flange bolt and side cover.

Installation is in the reverse order of removal.

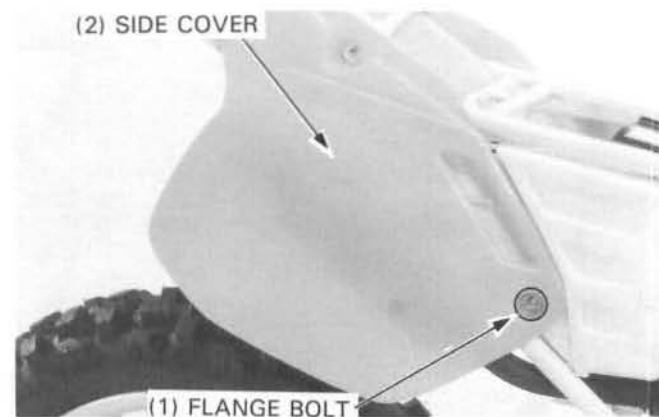

Fuel Tank

Removal/Installation

⚠ WARNING

- Gasoline is extremely flammable and is explosive under certain condition.

Remove the seat (page 2-2).
Turn the fuel valve OFF, and disconnect the fuel line.

Remove the radiator shroud bolts and washers.
Remove the fuel tank mounting bolts, unhook the band and remove the fuel tank.

Remove the bolts and radiator shroud.

Installation is in the reverse order of removal.

NOTE

- After installation, make sure there are no fuel leaks.
- Install the breather tube into the stem nut as shown.
- Perform fuel filter maintenance (See Owner's Manual).

(3) FUEL TANK MOUNTING BOLT (EACH SIDE)

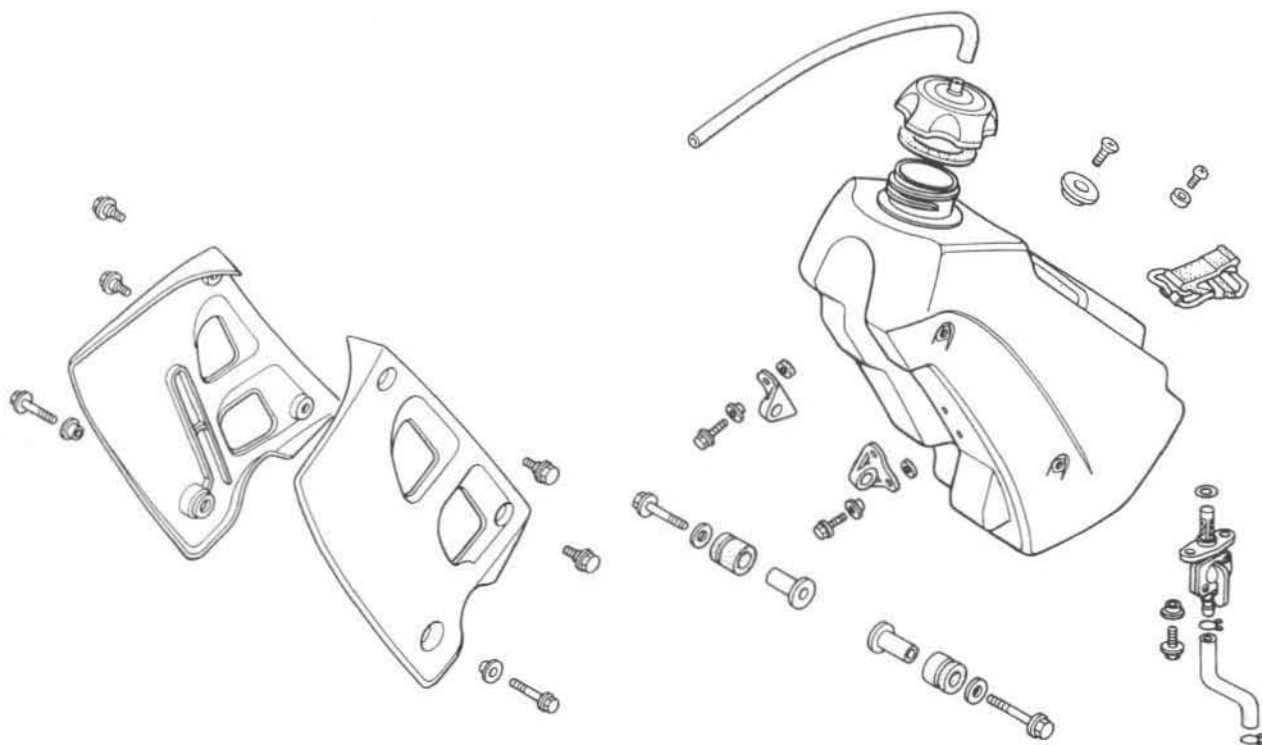
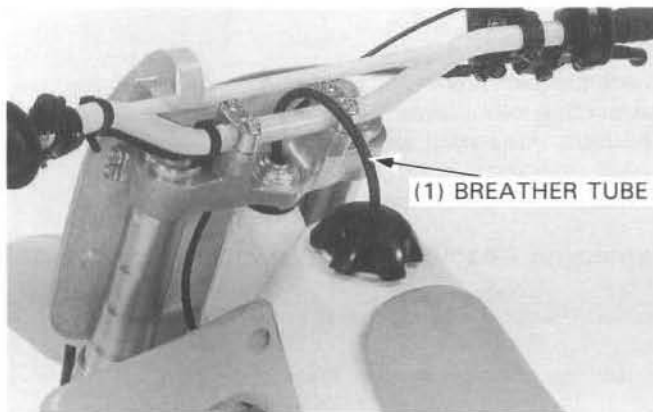
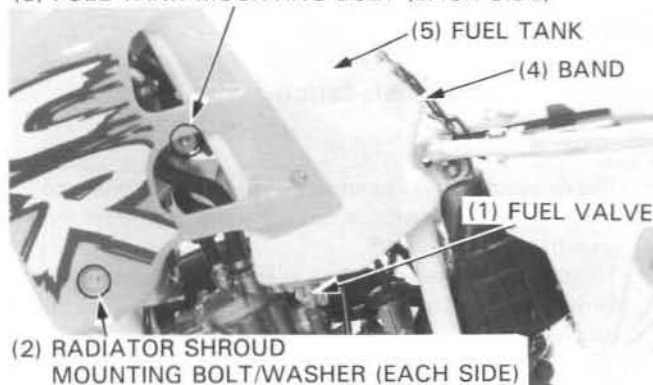

Exhaust Pipe

Silencer Removal/Installation

⚠ WARNING

- The exhaust system becomes extremely hot with the engine running and remains hot for some time after the engine has been shut-off. Touching the system while it is hot will cause severe burns. Allow some time for the system to cool before touching it.

Remove the seat and right side cover (page 2-2).
Remove the silencer case mounting bolt, silencer case and joint rubber.

Check the joint rubber for wear or damage.
Replace the joint rubber if necessary.
Check the glass wool packing maintenance see page 3-14.

Installation is in the reverse order of removal.

Expansion Chamber Removal/Installation

Remove the seat and right side cover (page 2-2).

Loosen the chamber bracket bolts.

Unhook and remove the chamber springs.
Remove the mounting bolts and expansion chamber.

Installation is in the reverse order of removal.

NOTE

- Install the joint rubber securely.

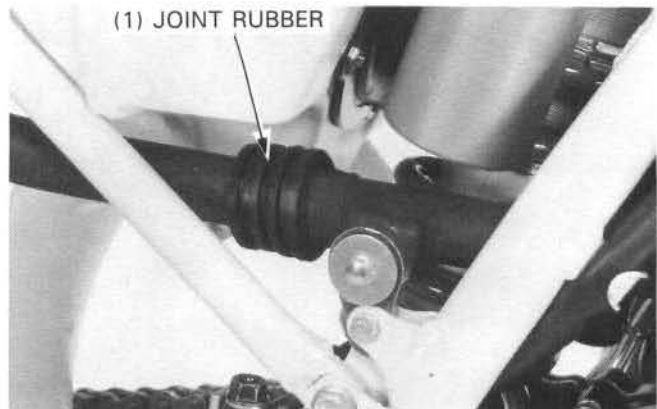
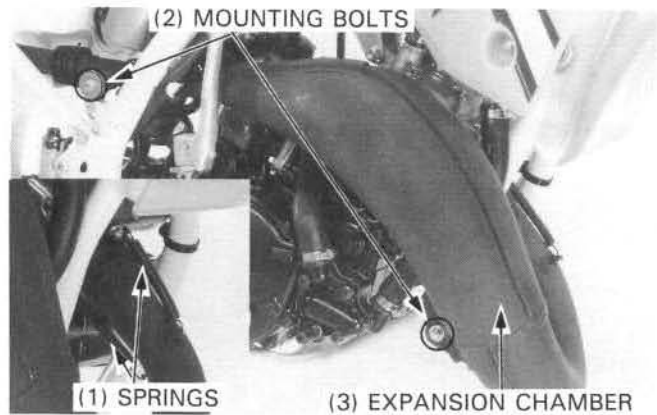
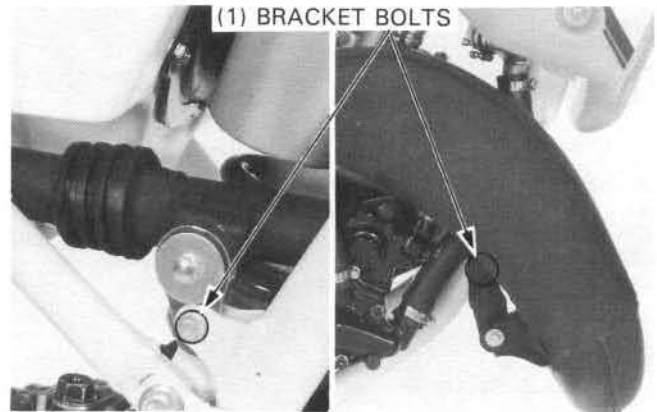
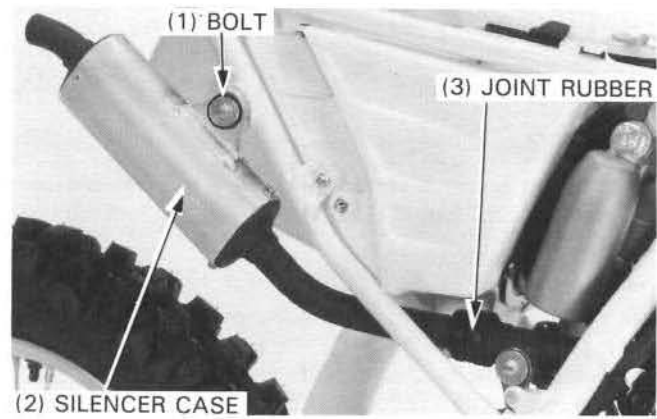

Sub-frame

Removal

Remove the seat (page 2-2).

Loosen the air filter connecting tube clamp screw.

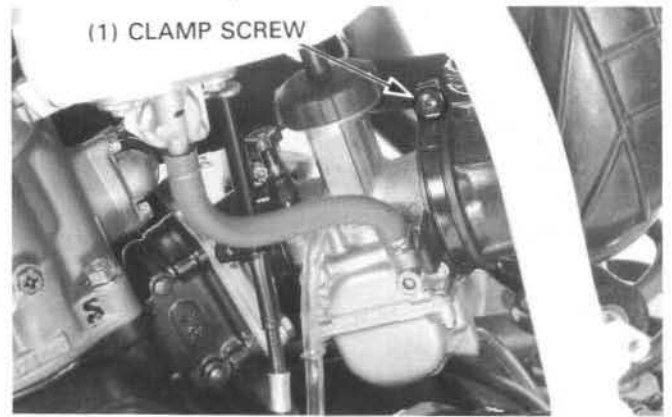

Remove the three sub-frame mounting bolts.
Remove the sub-frame by pulling it straight backward.

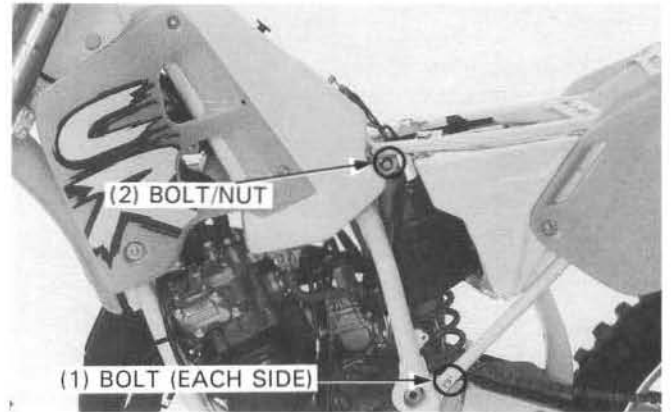

Installation

Loosely attach the upper and lower ends of the sub-frame to the main-frame while connecting the expansion chamber to the silencer pipe with the joint rubber and the air filter connecting tube to the carburetor.

Tighten the screw on the connecting tube clamp.

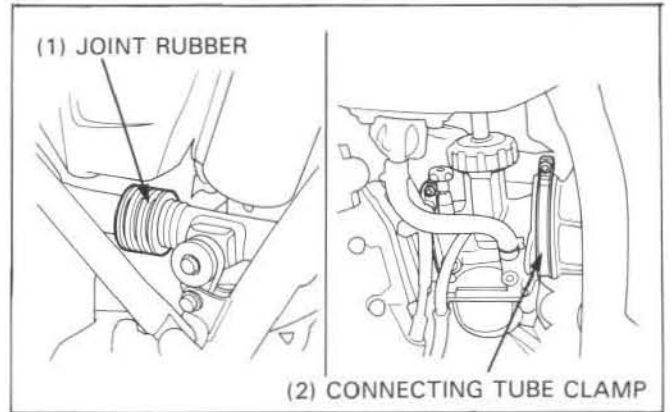

Tighten the sub-frame mounting bolts and nut to the specified torque.

Torque: 27 N·m (2.7 kg-m, 20 ft-lb)

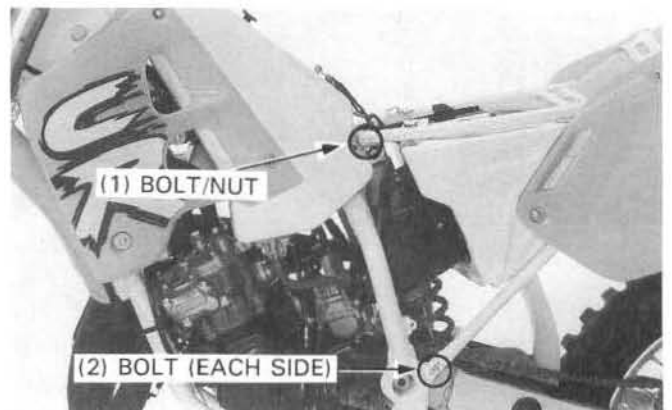

MEMO

RIDE RED

3. Maintenance

Service Information	3-1	Drive/Driven Sprockets	3-12
Service Access Guide	3-2	Brake Fluid	3-12
Competition Maintenance Schedule	3-4	Brake Pad Wear	3-13
Throttle Operation	3-6	Brake System	3-13
Air Filter	3-6	Clutch System	3-13
Spark Plug	3-8	Control Cables	3-14
Radiator Coolant	3-8	Expansion Chamber/Silencer	3-15
Cooling System	3-8	Suspension	3-15
Transmission Oil	3-9	Swingarm/Shock Linkage	3-17
Drive Chain	3-10	Nuts, Bolts, Fasteners	3-17
Drive Chain Sliders	3-11	Wheels/Tires	3-17
Drive Chain Rollers	3-11	Steering Head Bearings	3-18

Service Information

Specifications

Engine		Standard	Service Limit
Item			
Transmission oil capacity	At draining	0.57 liter (0.60 US qt, 0.50 Imp qt)	—
	At disassembly	0.65 liter (0.69 US qt, 0.57 Imp qt)	—
Recommended transmission oil		Honda GN4 4-Stroke Oil or equivalent API Service Classification: SF or SG SAE 10W-40	—
Clutch lever free play		10–20 mm (3/8–3/4 in)	—
Throttle grip free play		3–5 mm (1/8–1/4 in)	—
Recommended spark plug (or equivalent) [Optional]	CHAMPION	QN-84 [QN-59G]	—
	NGK	BR9EG [BR9EV]	—
	NIPPONDENSO	W27ESR-V [W27ESR-G]	—
Spark plug gap		0.5–0.6 mm (0.020–0.024 in)	—

Frame		Standard	Service Limit
Item			
Drive chain slack		35–40 mm (1-3/8–1-9/16 in)	—
Chain tensioner roller O.D.		—	25 mm (0.98 in)
Chain slider (from upper surface)		—	5 mm (0.2 in)
Tire size	Front	80/100–21 51M	—
	Rear	100/100–18 59M	—
Tire pressure	Front	100 kPa (1.0 kg/cm ² , 15 psi)	—
	Rear	100 kPa (1.0 kg/cm ² , 15 psi)	—

Torque Values

Oil check bolt	10 N·m (1.0 kg-m, 7 ft-lb)
Oil drain bolt	30 N·m (3.0 kg-m, 22 ft-lb)
Drive chain roller bolt	22 N·m (2.2 kg-m, 16 ft-lb)
Brake lever adjuster lock nut	6 N·m (0.6 kg-m, 4.3 ft-lb)
Rear axle nut	95 N·m (9.5 kg-m, 69 ft-lb)
Spoke nipple	3.8 N·m (0.38 kg-m, 2.8 ft-lb)
Rim lock	13 N·m (1.3 kg-m, 9.5 ft-lb)

Service Access Guide

- The following shows the locations of the parts that must be removed for maintenance.
- Refer to section 2 (Frame/body panels/exhaust system), for the parts to be removed for service.
For example: AIR FILTER (Contamination, clogging, replacement): Parts
 - Seat — The parts that must be removed for service.

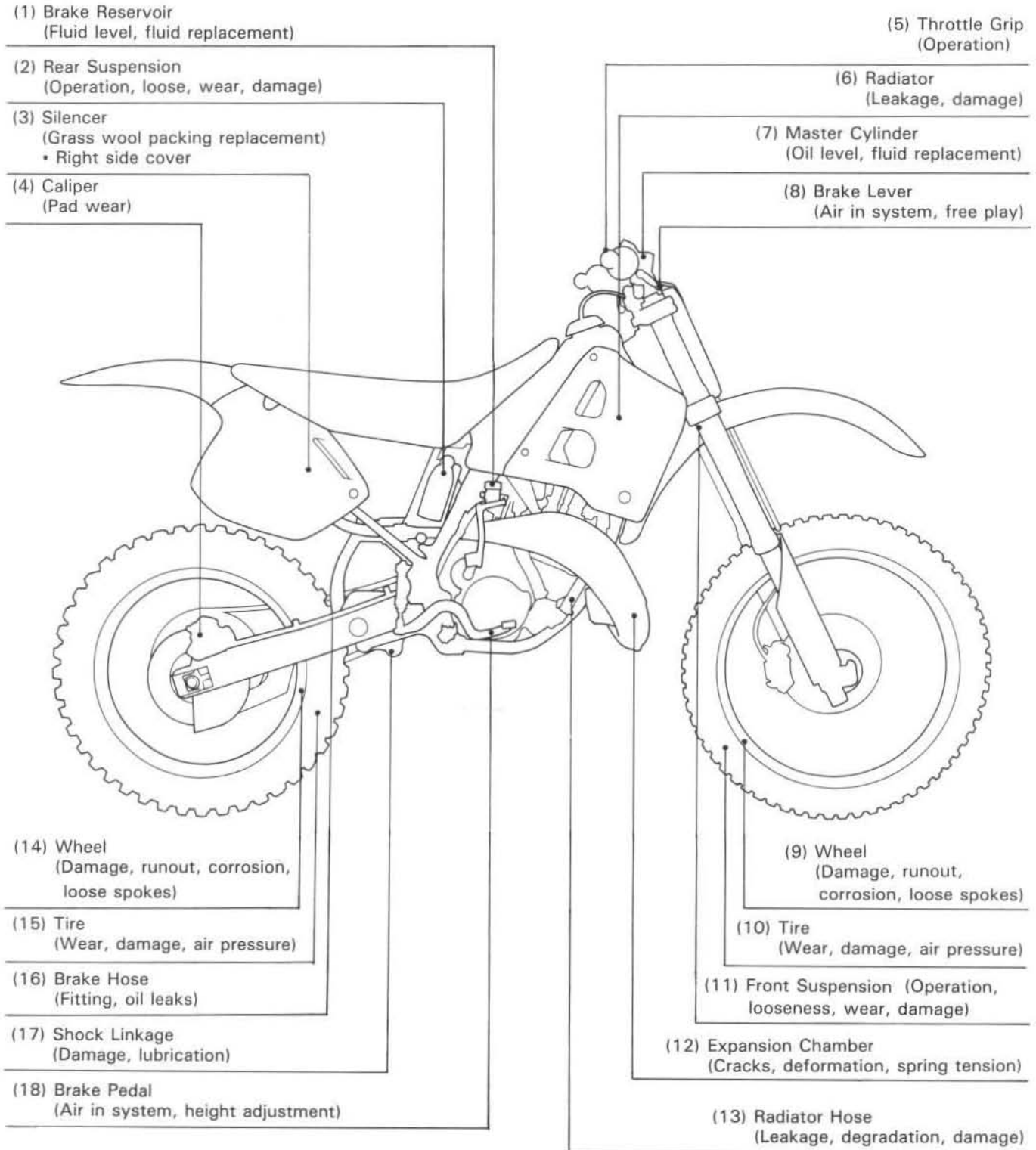

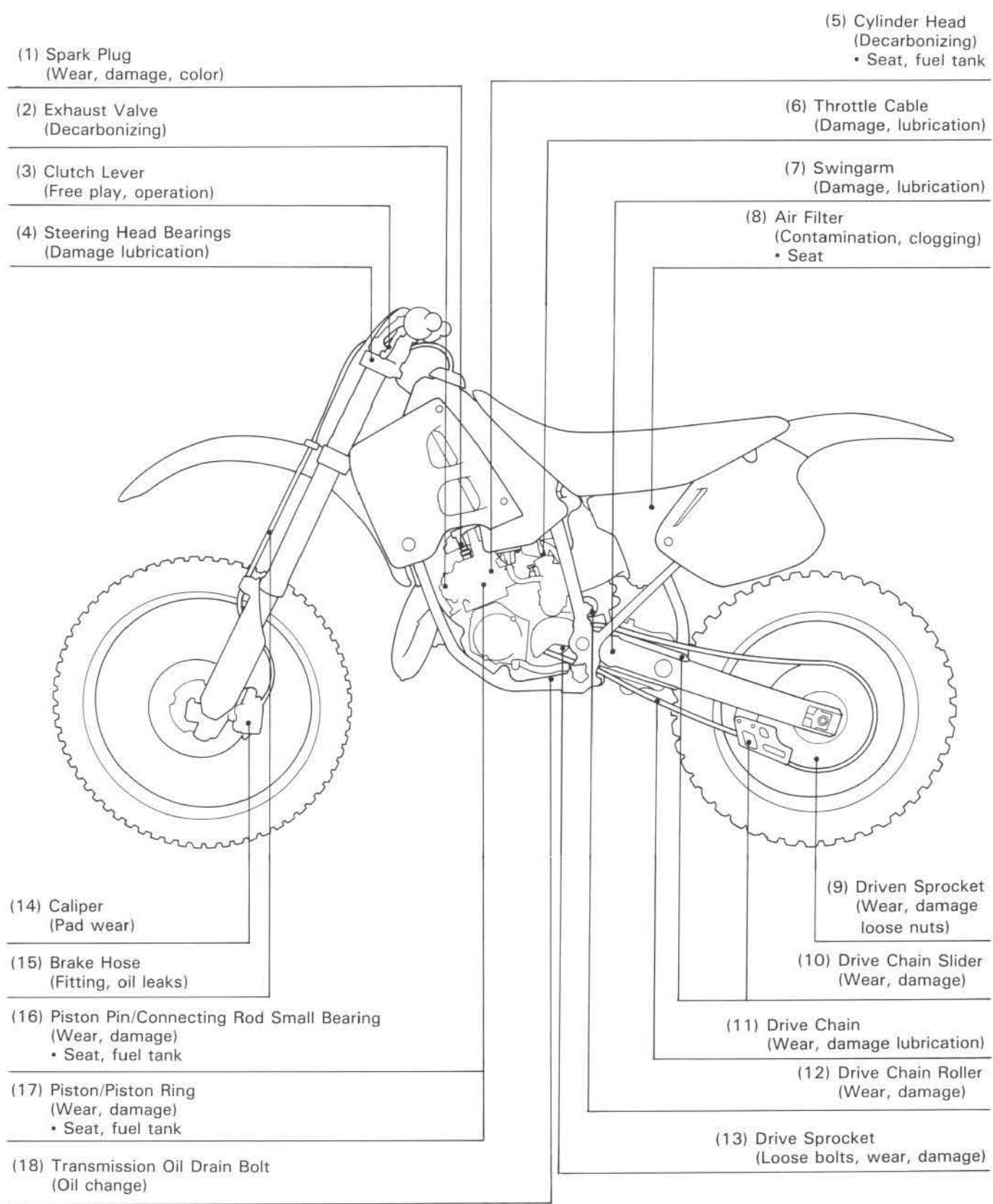

Competition Maintenance Schedule

Perform the PRE-RIDE INSPECTION in the Owner's Manual at each scheduled maintenance period.

I: Inspect and Clean, Adjust, Lubricate or Replace if necessary.

C: Clean, R: Replace, L: Lubricate.

Item	Frequency	Note	Each race or about 2.5 hours	Every 3 races or about 7.5 hours	Every 9 races or about 22.5 hours	Refer to page
Throttle Operation			I			3-6
Air Filter		Note 1	C			3-6
Spark Plug			I	R		3-8
Radiator Coolant		Note 2	I			3-8
Cooling System			I			3-8
Cylinder Head Decarbonizing				C		7-3
Exhaust Valve Decarbonizing			C			8-5
Piston And Piston Ring				R		7-8
Piston Pin And Connecting Rod Small End Bearing					R	7-8, 9
Transmission Oil				R		3-9
Drive Chain			I, L	R		3-10
Drive Chain Sliders			I			3-11
Drive Chain Rollers			I			3-11
Drive Sprocket			I			3-12
Driven Sprocket			I			3-12
Brake Fluid		Note 2	I			3-12
Brake Pads Wear			I			3-13
Brake System			I			3-13
Clutch System			I			3-13
Control Cables			I, L			3-14
Expansion Chamber/Silencer			I			3-15
Suspension			I			3-15
Swingarm/Shock Linkage				L		3-17 12-23, 26
Fork Oil		Note 3		R		11-16
Nuts, Bolts, Fasteners			I			3-17 1-11
Wheels/Tires			I			3-17
Steering Head Bearings					I	3-18

This maintenance schedule is based upon average riding conditions. Machines subjected to severe use require more frequent servicing.

- Notes: 1. Clean after every moto for dusty riding conditions.
 2. Replace every 2 years. Replacement requires mechanical skill.
 3. Replace after the first break-in ride.

Additional Items Requiring Frequent Replacement

Engine		
Item	Cause	Remark
Cylinder head gasket	Compression leak	Replace whenever disassembled
Reed valve	Damage or fatigue	
Clutch disc	Wear or discoloration	Replace whenever disassembled Replace whenever disassembled
Cylinder base gasket	Leakage	
Right crankcase cover gasket	Damage	
H.P.P. valve cover gasket	Damage	

Frame		
Item	Cause	Remark
Front/rear tire	Wear	Minimum cleat height: 8 mm (5/16 in) Minimum thickness: 1 mm (0.04 in)
Front/rear brake pad	Wear	
Sub-frame mounting bolts	Fatigue or damage	
Chain guide plate	Wear or damage	
Side cover	Damage	
Front number plate	Damage	
Front/rear fender	Damage	
Clutch lever/holder	Play or damage	
Brake lever	Play or damage	
Handlebar	Bent or cracked	
Throttle housing	Damage	
Grip rubber	Damage	
Gearshift pedal	Damage	
Brake pedal	Damage	
Chain adjuster/bolt	Damage	
Air filter element	Damage	
Exhaust chamber spring/hook	Fatigue or damage	

Note: These parts and their possible replacement schedule are based upon average riding conditions. Machines subjected to severe use require more frequent servicing.

Throttle Operation

Check for smooth throttle grip operation from the fully open to the fully closed position and automatic closing in all steering positions.

Inspect the throttle cable damage, or kinks.

Replace the cable as required.

Measure throttle grip free play at the throttle grip flange.

Throttle Grip Free Play: 3–5 mm (1/8–1/4 in)

Minor adjustments are made with the adjuster on the housing.

Slide the rubber protector down and loosen the lock nut.

Tighten the lock nut.

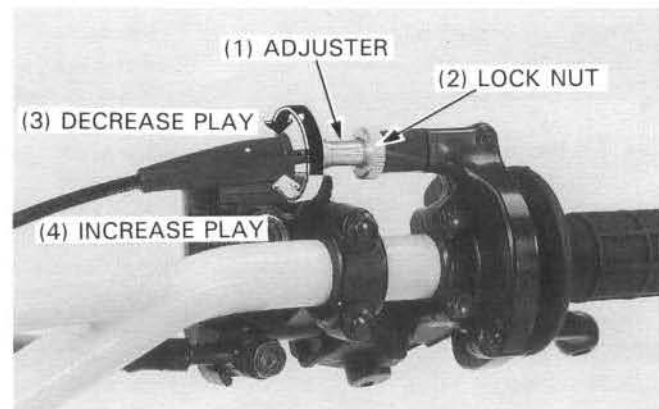
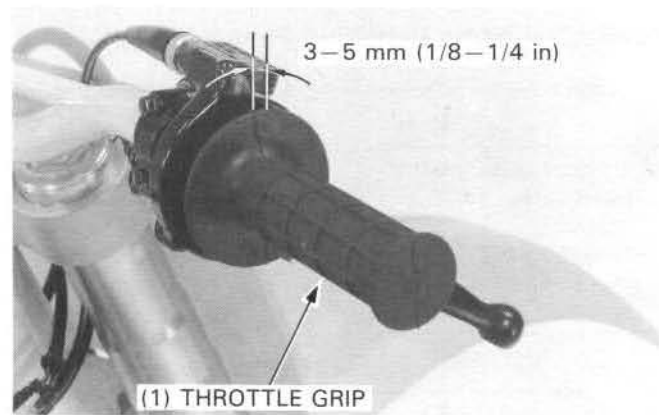

Major adjustments are made at the carburetor end of the cable.

Turn in the adjuster at the throttle grip in all the way.

Pull the carburetor rubber cap up, loosen the lock nut and turn the adjuster.

Tighten the lock nut and reinstall the rubber cap.

Check that the throttle grip turns smoothly and returns completely in all steering positions.

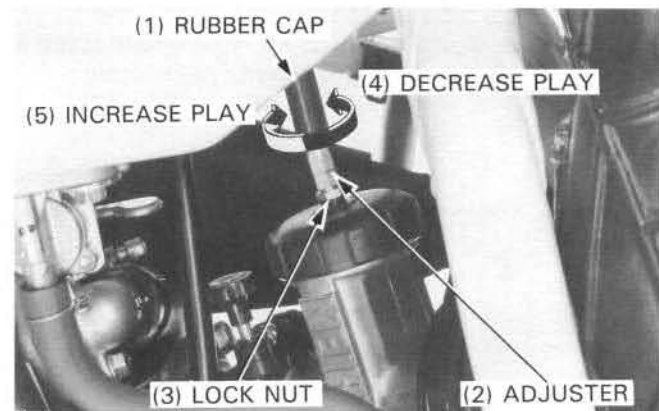

Air Filter

Remove the seat (page 2-2).

Remove the air filter case cover.

NOTE

- The air filter cover should only be used when riding in wet conditions.



Loosen the air filter retaining bolt.

Remove the air filter assembly.

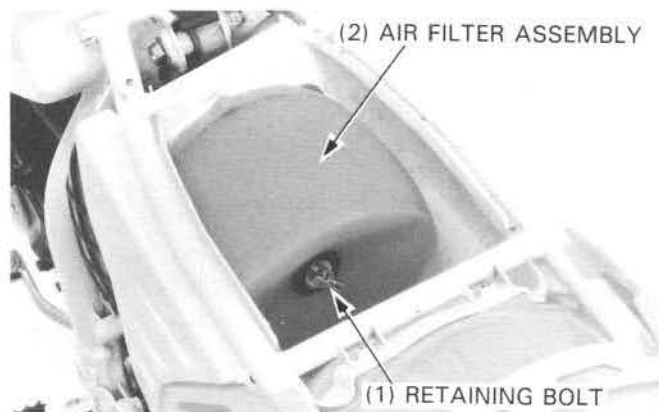

Remove the air filter element from the air filter holder.

Thoroughly wash the element in clean non-flammable cleaning solvent, then wash in a solution of hot water and dishwashing liquid soap.

Clean the inside of the air filter case.

⚠ WARNING

- Never use gasoline or low flash point solvents for cleaning the air filter element. A fire or explosion could result.

NOTE

- The element is made in two pieces: inner and outer, which can't be separated.

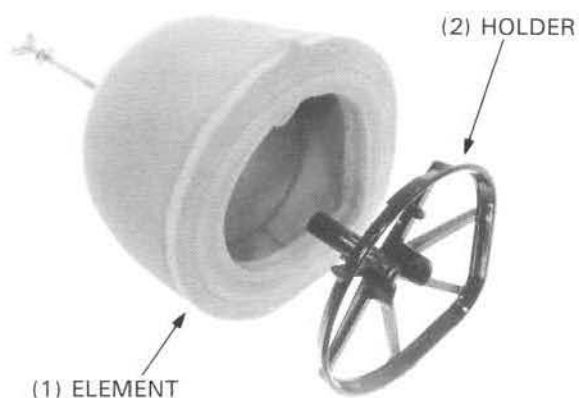

Allow the element to dry thoroughly.

After drying, soak the element in clean Honda Foam Filter Oil or an equivalent.

Apply air filter oil to the entire surface of each element and rub it with both hands to saturate the element with oil. Gently squeeze out excess oil.

Apply thin coat of Honda white lithium grease or an equivalent to the sealing surface.

Assemble the air filter element and holder and put the air filter retaining bolt through the assembly.

Install the assembly into the air filter case while aligning the tab on the filter element and index mark on the air filter case. Tighten the retaining bolt securely.

Install the air filter cover.

Install the seat (page 2-2).

CAUTION

- If the air filter assembly is not installed correctly dirt and dust may enter the engine resulting wear of the piston ring and cylinder.

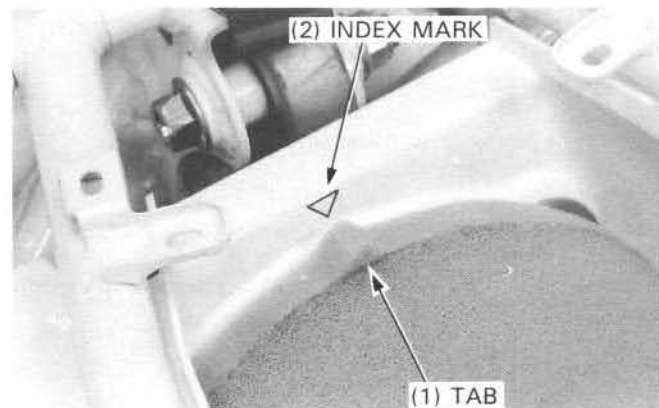

Spark Plug

Remove the spark plug and inspect it for damage.

Discard it if the insulator is cracked or chipped.

Recommended Spark Plug (or equivalent):

CHAMPION:	QN-84 [QN-59G]
NGK:	BR9EG [BR9EV]
NIPPONDENSO:	W27ESR-V [W27ESR-G]
	[]: Optional

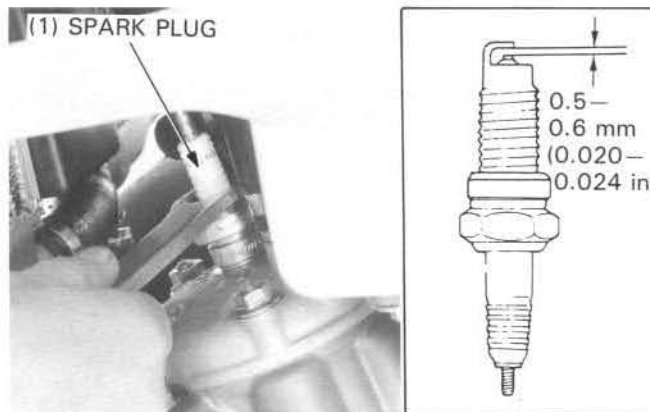

If necessary, adjust the gap by carefully bending the side electrode.

Measure the gap again; if it is correct, install the plug.

Spark Plug Gap: 0.5—0.6 mm (0.020—0.024 in)

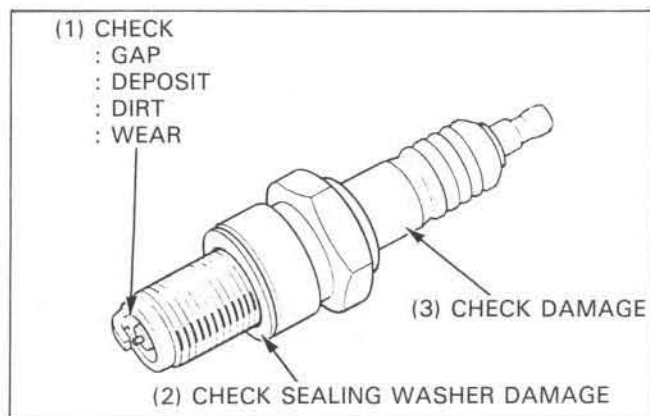

Radiator Coolant

Check the coolant level with the engine cold, it should be up to the filler neck.

Add coolant as required (page 5-3).

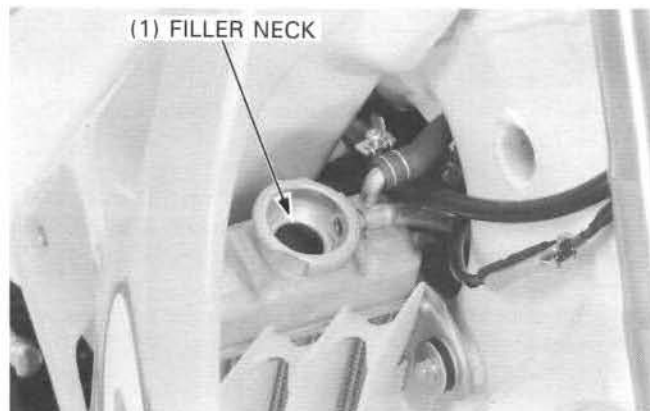

Cooling System

Remove the radiator shrouds.

Inspect the hoses for cracks and deterioration.

Use low pressure water and a soft brush to rinse off any dirt that may be stuck on the radiator core.

Replace if necessary.

Check the tightness of the hose clamps and radiator mounting bolts.

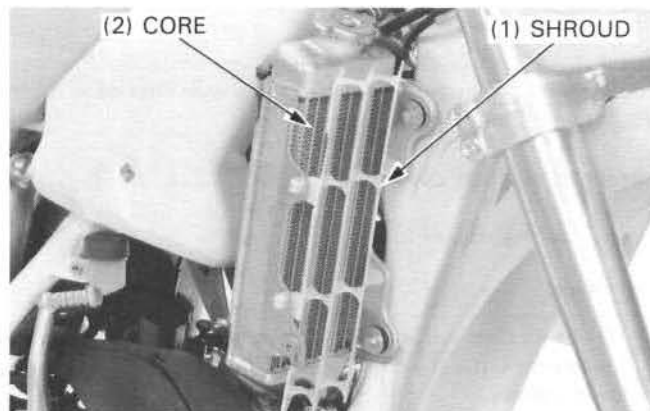

Transmission Oil

Oil Level Check

Place the motorcycle in an upright and level position.

Remove the oil filler cap and check bolt/sealing washer. If the oil level is correct, a small amount of oil will run from the hole. If the oil does not flow out, add the recommended oil slowly through the oil filler hole until the oil starts to flow out of the check hole.

Stop adding oil when it begins to flow out. Install the oil check bolt.

Torque: 10 N·m (1.0 kg-m, 7 ft-lb)

After checking the oil level, install the oil filler cap and be sure that the cap and oil check bolt are tightened securely.

Oil Change

NOTE

- Transmission oil should be changed at least every 3 races or 7.5 hours of running to ensure consistent performance and maximum service life of both transmission and clutch components.
- Warm-up the engine before draining the oil. This ensures complete and rapid draining.

⚠ WARNING

- If the engine must be running to do some work, make sure the area is well ventilated. Never run the engine in an enclosed area. The exhaust contains poisonous carbon monoxide gas that can cause loss of consciousness and may lead to death.

Remove the oil filler cap from the right crankcase cover.

Place an oil drain pan under the engine to catch the oil, then remove the drain bolt.

CAUTION

- Used engine oil may cause skin cancer if repeatedly left in contact with the skin for prolonged periods. Although this is unlikely unless you handle used oil on a daily basis, it is still advisable to thoroughly wash your hands with soap and water as soon as possible after handling used oil.

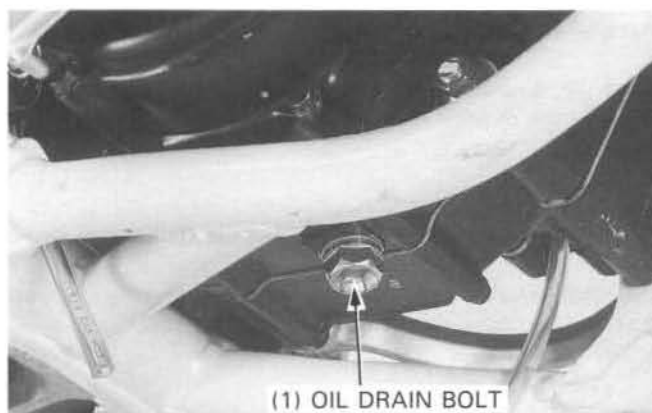

Maintenance

After the oil has been completely drained, install the drain bolt with a new sealing.

Torque: 30 N·m (3.0 kg·m, 22 ft·lb)

Capacity: 0.57 liter (0.60 US qt, 0.50 Imp qt) at draining

**Recommended Oil: Honda GN4 4-Stroke Oil or equivalent
SAE 10W-40**

NOTE

- Use this specified capacity only as a guide: add oil until it flows out of the oil check bolt hole, allow it to stop flowing out, then reinstall and tighten the oil check bolt and sealing washer.

Reinstall the oil filler cap.

Start the engine and check for leaks.

Stop the engine and recheck the oil level.

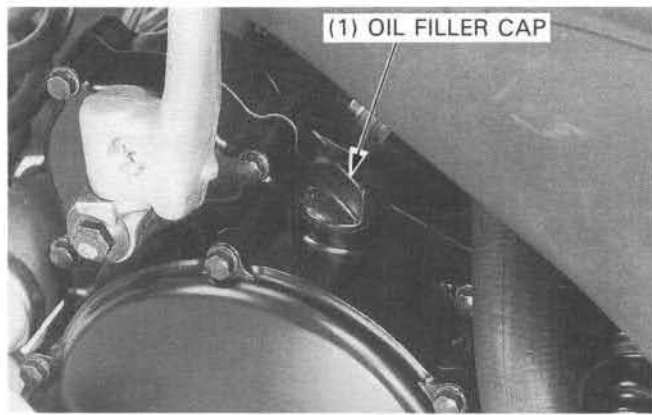

Drive Chain

NOTE

- For maximum service life, the drive chain should be cleaned and lubricated each outing.

Stop the engine and shift the transmission into neutral.

Place a work stand or box under the engine.

Carefully remove the master link clip with pliers.
Remove the master link and the drive chain.

Clean the drive chain in high flash point solvent and wipe it dry.

Inspect the chain for possible wear or damage; replace any chain that has damaged rollers or loose fitting links.

Reinstall the drive chain and lubricate it with Pro Honda Chain Lube or its equivalent.

Note the direction of the master link clip. Its open end should face in the opposite direction of the wheel rotation.

Adjustment

Raise the rear wheel off the ground by placing a work stand under the engine.

Measure the chain slack, in the upper run, mid-way between the sprocket.

Chain Slack: 35–40 mm (1-3/8–1-9/16 in)

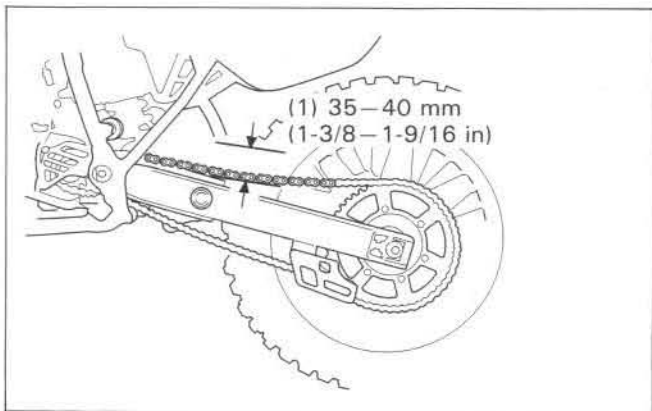
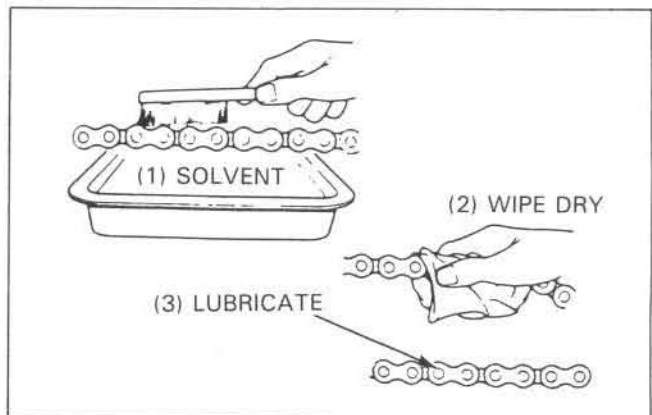
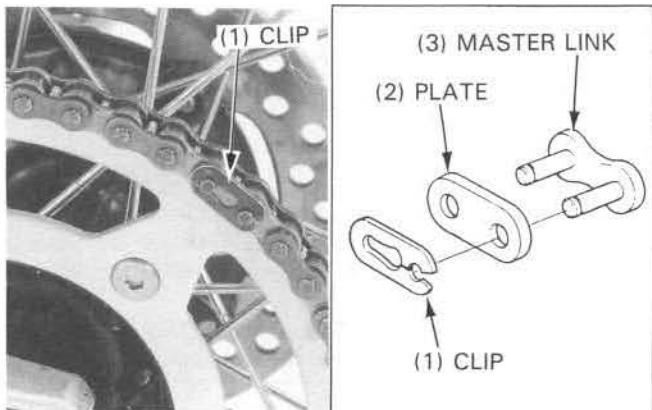

If the chain needs adjustment, loosen the axle nut and turn the adjusting bolts to increase or decrease slack.

Check that the chain adjuster index marks are in the same position on each side, and tighten the axle nut to the specified torque.

Torque: 95 N·m (9.5 kg-m, 69 ft-lb)

After tightening the axle nut, seat the adjusting bolts snugly against the axle adjustment plates and tighten the adjuster lock nut.

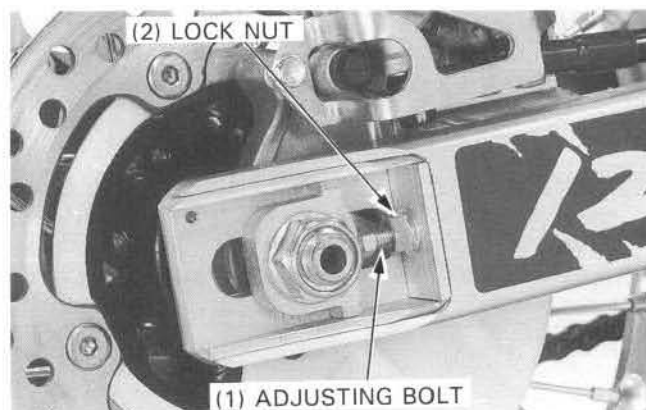

Drive Chain Sliders

Inspect the drive chain slider for excessive wear.

Service Limit: 5 mm (0.2 in) from upper surface

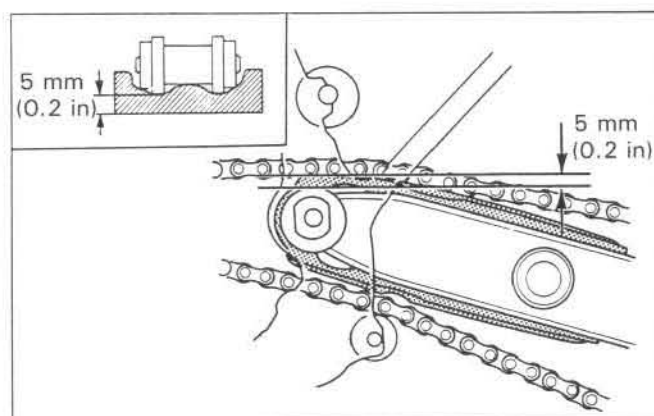

Check the chain guide and chain guide slider for wear or damage.

Replace the chain guide if it is damaged or worn.

Replace the chain guide slider if the chain is visible through the wear inspection window.

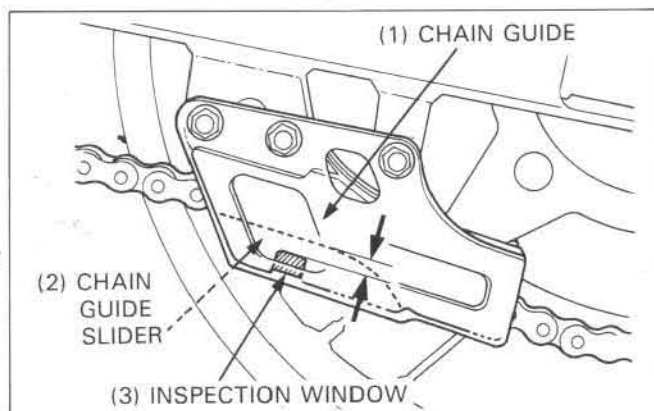

Drive Chain Rollers

Inspect the drive chain rollers for excessive wear or binding.

Service Limit: Minimum roller O.D.: 25 mm (0.98 in)

Replace if necessary, then torque the roller bolts.

Torque: 22 N·m (2.2 kg-m, 16 ft-lb)



Drive/Driven Sprockets

Inspect the sprocket teeth for excessive wear or damage. Replace if necessary.

NOTE

- Never install a new drive chain on worn sprockets or a worn chain on new sprockets. Installing a new part (chain or sprocket) with a worn part, will cause the new part to wear rapidly.

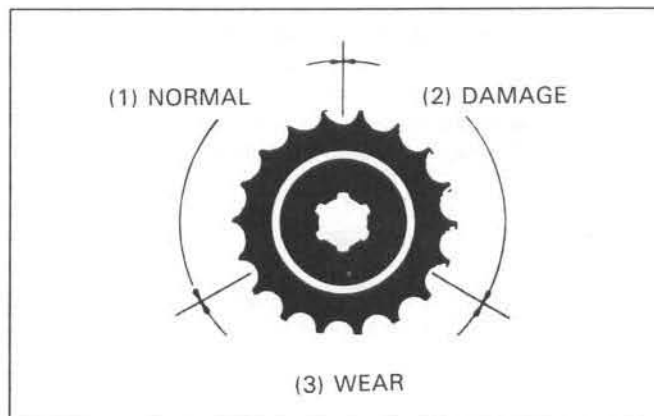

Brake Fluid

Fluid Level Inspection

Check the front brake fluid reservoir level. If the level is near the lower level mark, check the brake pad wear (page 3-13).

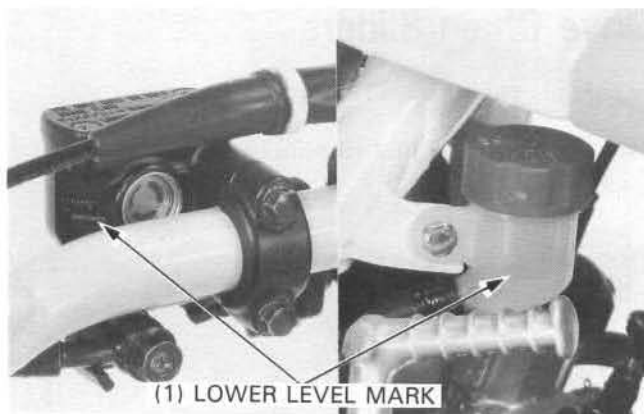

Fluid Filling

CAUTION

- Brake fluid will damage painted, plastic or rubber parts. Place a rag over these parts whenever the system is serviced.
- Do not mix different types of fluid, as they are not compatible.

Front:

Remove the cover, diaphragm and plate and fill the reservoir with DOT 3 or 4 brake fluid to the upper level mark. Check the entire system for leak.

Rear:

Remove the cap, diaphragm and plate and fill the reservoir with DOT 4 brake fluid to the upper level mark. Check the entire system for leaks.

Inspect the brake hose and fittings for deterioration, cracks or signs of leakage. Tighten any loose fittings.

Replace the hose and fittings as required.



Brake Pads Wear

Inspect the pads visually from under the caliper to determine the pad wear.

If either pad is worn anywhere to a thickness of 1 mm (0.04 in), both pads must be replaced.

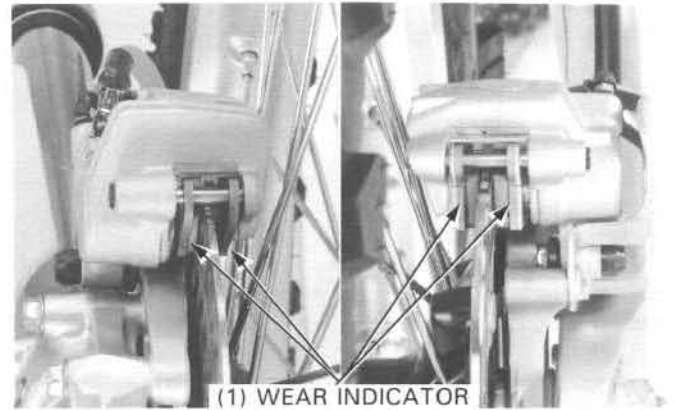

Brake System

Lever Position Adjustment

The brake lever position can be adjusted by loosening the lock nut and turning the adjuster.

Turning the adjuster clockwise moves the brake lever farther away from the grip; turning the adjuster counterclockwise moves the brake lever closer to the grip.

After adjustment, hold the adjuster and tighten the lock nut to the specified torque.

Torque: 6 N·m (0.6 kg-m, 4.3 ft-lb)

If the brake lever free play exceeds 20 mm (0.8 in), there is air in the system that must be bled. Refer to page 13-3 for brake system bleeding.

NOTE

- Apply grease to the contact faces of the adjuster bolt and piston.

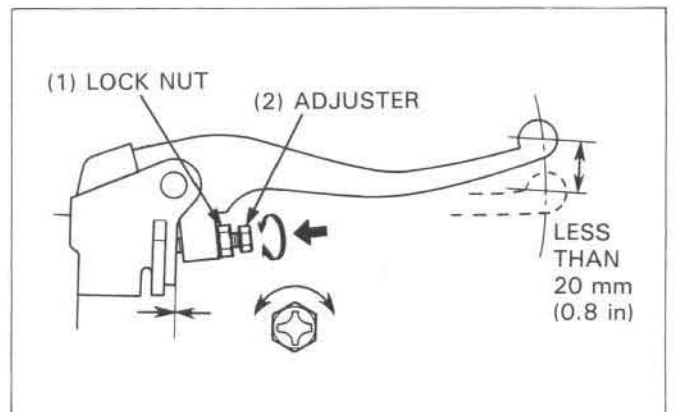

Brake Pedal Height

Adjust the brake pedal to the desired height by loosening the lock nut and turning the pedal height adjusting bolt. Tighten the lock nut.

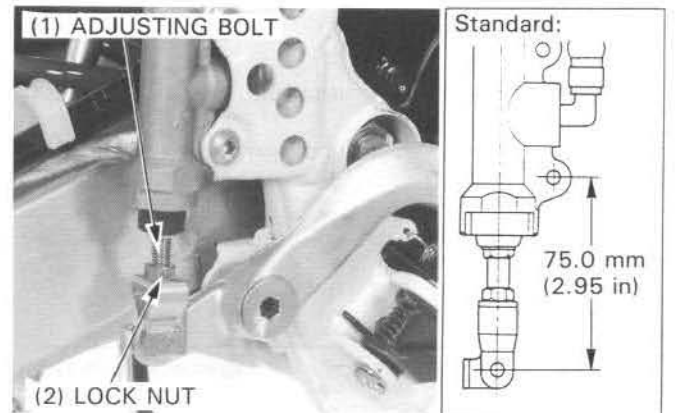

Clutch System

Measure the clutch free play at the lever end.

Free Play: 10–20 mm (3/8–3/4 in)

10–20 mm
(3/8–3/4 in)



Maintenance

Adjust as follows:

Minor adjustments are made at the adjuster on the lever.

Pull the cover back.
Loosen the lock nut and turn the adjuster.
Tighten the lock nut.

If the adjuster is threaded out near its limit and the correct free play cannot be obtained, turn the adjuster all the way in and back out one turn.

Tighten the lock nut, install the dust cover and make a major adjustment, as follows.

Major adjustments are performed with the in line cable adjuster behind the front number plate.

Loosen the lock nut and turn the adjuster.
Tighten the lock nut.

If proper free play cannot be obtained using both procedures or the clutch slips during the test ride, disassemble and inspect the clutch (See section 9).

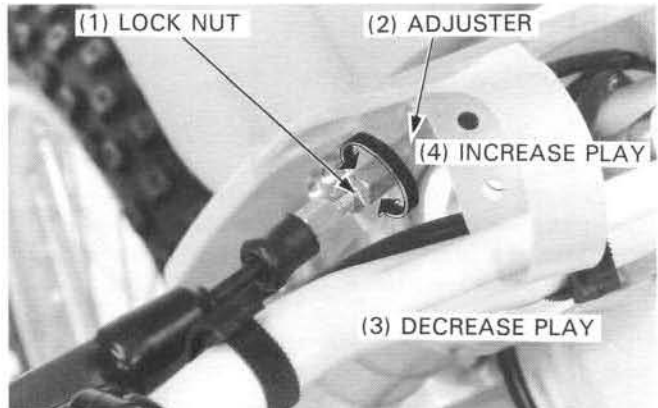
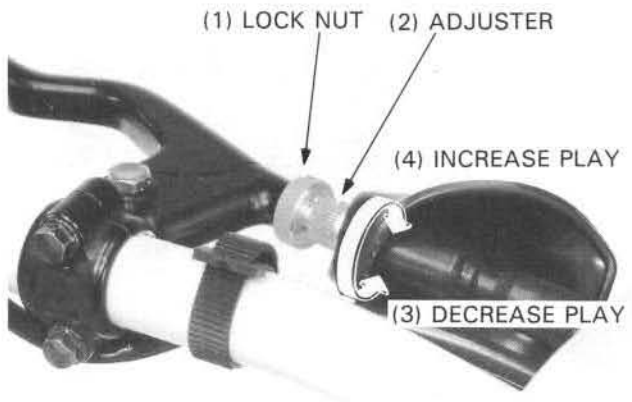

Control Cables

Remove the throttle cable end cover.

Disconnect the throttle cable upper end from the throttle grip.
Disconnect the clutch cable upper end from the clutch lever.

Thoroughly lubricate the cable pivot points with a commercially available cable lubricant.

NOTE

- It is not necessary to lubricate the cables anywhere except the pivot points.
If clutch lever or throttle operation is not smooth, replace the cable.

CAUTION

- Be sure the throttle returns freely from fully open to fully closed, automatically, in all steering position.

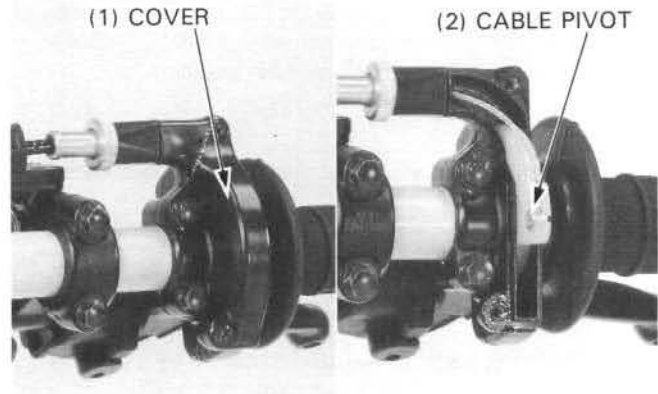

Expansion Chamber/Silencer

Silencer Glass Wool Replacement

Remove the silencer case (page 2-4).

Remove the silencer case bolts.
Pull out the inner pipe.

NOTE

- Hold the mounting tab of the silencer case gently in a vise using a shop towel or soft jaws to avoid damage.

Remove the glass wool packing.

Remove the carbon deposits from the inner pipe using a wire brush.

Install the new glass wool packing material onto the inner pipe.

NOTE

- Be careful not to damage the glass wool packing.

Apply muffler sealant (high-temperature silicone) in the area shown.

Insert the inner pipe and packing into the silencer case and align the bolt holes.

Install and tighten the silencer case bolts.

Wipe off the excess sealant.

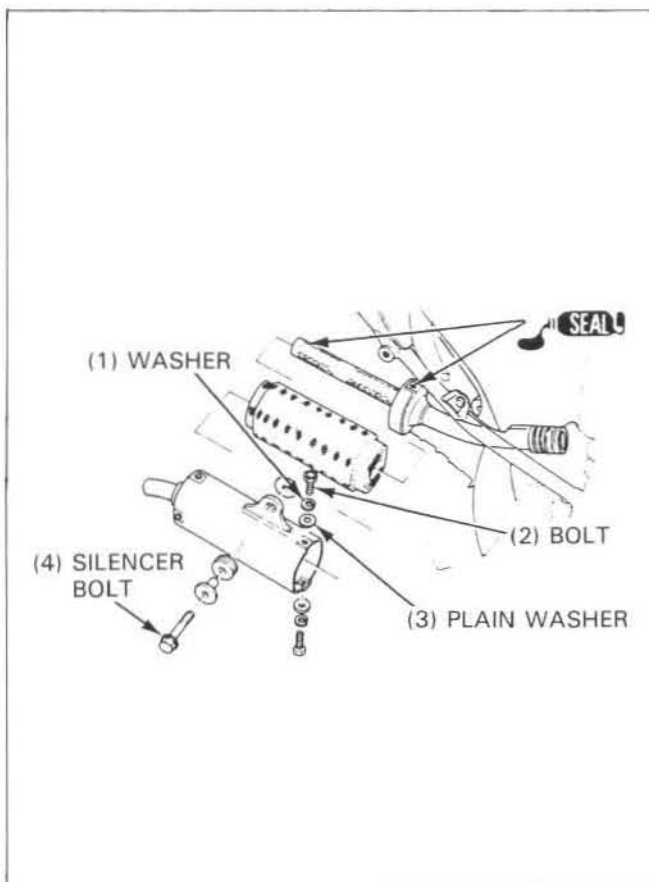
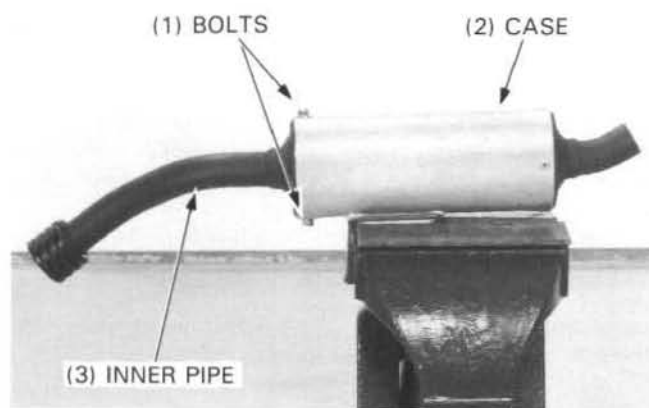

Suspension

Front:

Check the action of the fork by compressing the suspension several times.

Check the entire fork assembly for signs of leaks, damage or loose fasteners.

Make sure that the fork protectors and dust seals are clean and not packed with mud and dirt.

Replace any component which is unserviceable.
See section 11 for fork oil change.



Maintenance

Air pressure acts as a progressive spring and affects the entire range of fork travel.

Air is an unstable gas; it increases in pressure as it is worked (such as in a fork), so the fork action on your CR will get stiffer as the race progresses.

Release build-up air pressure from the fork legs between heats. Be sure the fork is fully extended with the front tire off the ground. Loosen the pressure release screws fully, then tighten them securely.



Rear:

Bounce the rear of the motorcycle up and down to check for proper operation.



Push and pull the rear wheel side ways (in alignment with the axle) to check for play in the swingarm.



Remove the sub-frame (page 2-5).

Check the damper rod is not bent or oil leaking from the seals or hose fittings.

Check that the shock spring preload adjusting/lock nuts are tightened securely.

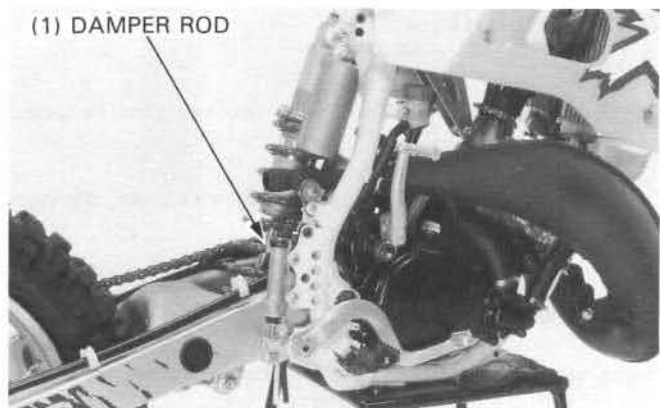

Swingarm/Shock Linkage

Place the motorcycle on a work stand or box to raise the rear wheel off the ground.

Move the rear wheel sideways with force to see if the swingarm bearings are worn.

Replace the bearing if excessively worn (page 12-27).

Check that the shock linkage, spherical bearing and needle bearings are not damaged.

Disassemble, clean, inspect the swingarm and shock linkage pivot bearings and related seals each 3 races or about 7.5 hours of running (page 12-23 through 12-29).

Lubricate and reassemble.



Nuts, Bolts, Fasteners

Check that all chassis nuts and bolts are tightened to their correct torque values.

Check that all cotter pins and clips are in place and properly secured.

Wheels/Tires

Check the tire for cuts, embedded objects, or excessive wear.

Tire Pressure (Front and Rear):
100 kPa (1.0 kg/cm², 15 psi)

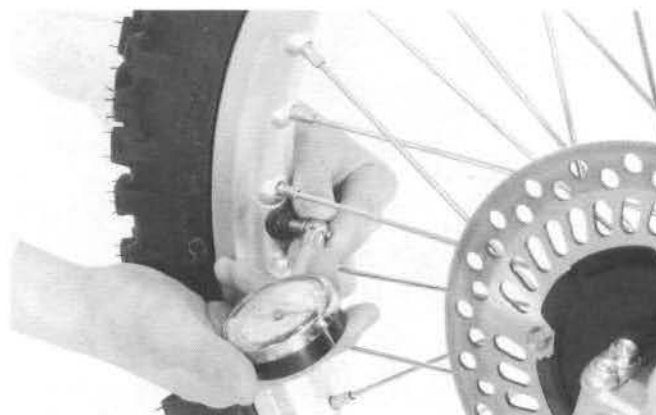

Inspect the wheel rims and spokes for damage.

Torque any loose spokes and rim locks.

Torque:

Spokes: 3.8 N·m (0.38 kg-m, 2.8 ft-lb)

Rim lock: 13 N·m (1.3 kg-m, 9.5 ft-lb)

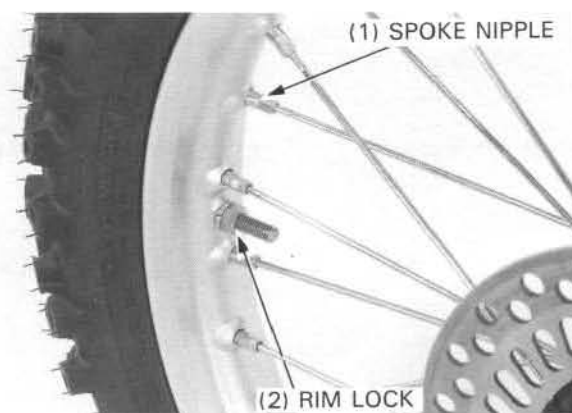

Steering Head Bearings

Raise the front wheel off the ground and check that the fork rotates freely.

Check that the control cables do not interfere with fork rotation.

If the handlebar moves unevenly, binds or has vertical movement, adjust the steering head bearings by turning the steering head adjusting nut (page 11-24).



MEMO

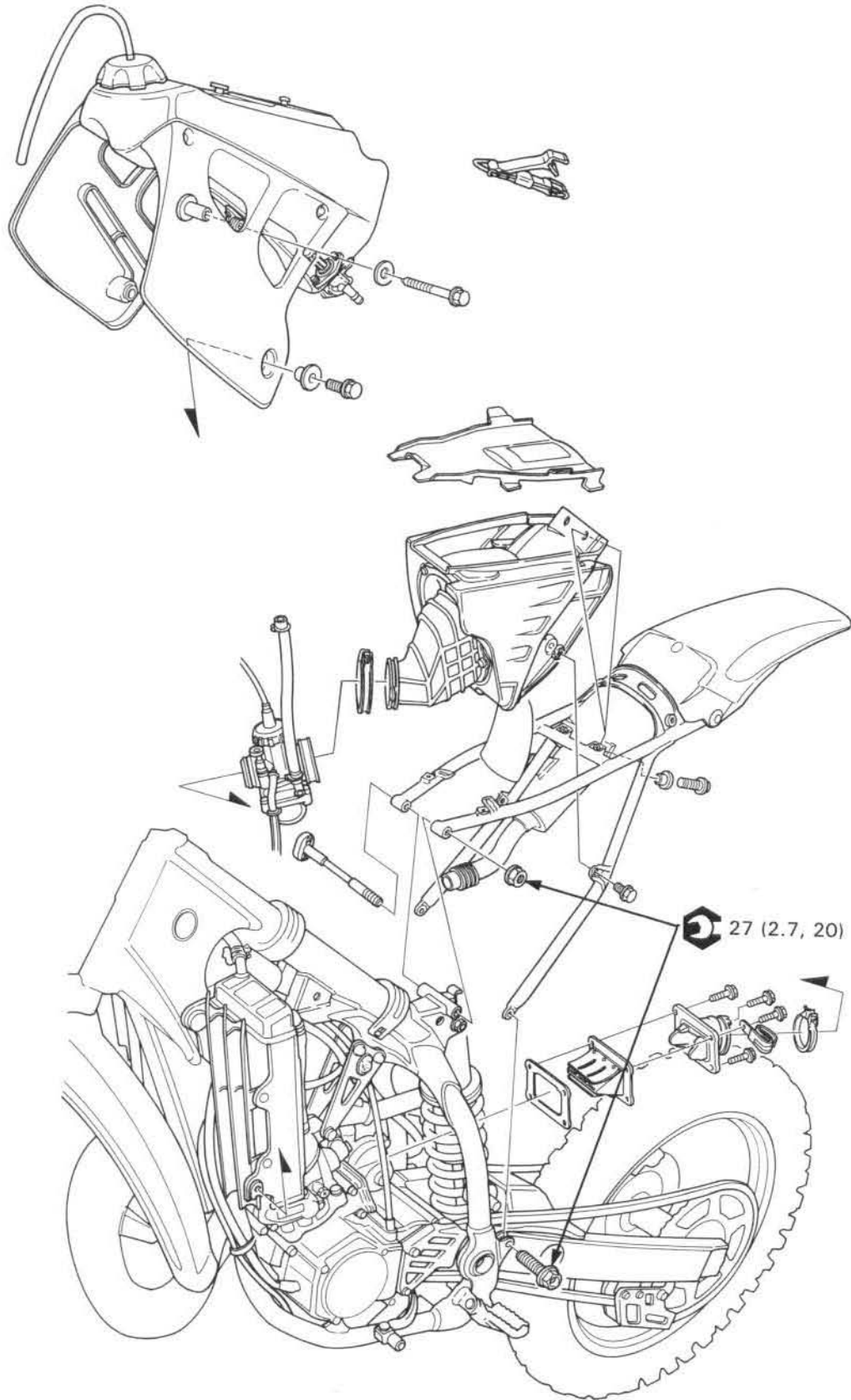

4. Fuel System

4

Service Information	4-1	Carburetor Removal/Disassembly	4-6
Troubleshooting	4-2	Carburetor Assembly/Installation	4-7
Minor Carburetor Adjustment	4-3	Reed Valve	4-10
Major Carburetor Adjustment	4-3	Air Filter Case	4-10
Tuning For Special Condition	4-5		

Service Information

General

▲ WARNING

- Gasoline is extremely flammable and is explosive under certain conditions.
- Bending or twisting the control cables will impair smooth operation and could cause the cables to stick or bind, resulting in loss of vehicle control.
- Work in a well ventilated area. Smoking or allowing flames or sparks in the work area or where gasoline is stored can cause a fire or explosion.
- Refer to section 2 for fuel tank removal and installation.
- When disassembling fuel system parts, note the locations of the O-rings. Replace them with new ones on reassembly.
- Before disassembling the carburetor, place the suitable container under the carburetor, remove the plug and drain the carburetor.
- After removing the carburetor, wrap the intake port of the engine with a shop towel or cover it with piece of tape to prevent any foreign material from dropping into the engine.

NOTE

- If the vehicle is to be stored for more than one month, drain the float bowl. Fuel left in the float bowl may cause clogged jets resulting in hard starting or poor driveability.

Specifications

Item	Specification
Fuel tank capacity	7.5 liter (2.0 US gal, 1.6 Imp gal)
Recommended fuel	Premium or unleaded gasoline (Octane rating 92–100), RON
Specified engine oil	Honda HP2 2-Stroke Oil
Fuel/oil mixing ratio	32 : 1
Carburetor identification mark	PJ15E
Carburetor type	Piston valve
Venturi diameter	36 mm (1.42 in)
Float level	16.0 mm (0.63 in)
Air screw initial opening	2 turns out
Jet needle	R1469NS-3
Main jet	#172
Slow jet	#58
Jet needle clip position	3rd groove

Torque Values

Sub frame mounting bolt	27 N·m (2.7 kg-m, 20 ft-lb)
Carburetor insulator	12 N·m (1.2 kg-m, 9 ft-lb)

Tool

Float level gauge	07401–0010000
-------------------	---------------

Troubleshooting

Engine Won't Start

- Too much fuel getting into cylinder
 - Air filter clogged
 - Flooded carburetor
- Intake air leak
- Fuel contaminated/deteriorated
- No fuel to carburetor
 - Fuel filter clogged
 - Fuel tube clogged
 - Fuel valve stuck
 - Float level misadjusted
 - Fuel tank breather tube clogged

Engine Stall, Or Runs Poorly

- Ignition malfunction
- Low compression
- Rich mixture
- Lean mixture
- Air filter clogged
- Intake air leak
- Fuel contaminated

Lean Mixture

- Fuel jets clogged
- Fuel tank breather tube clogged
- Fuel filter clogged
- Fuel line restricted
- Float valve faulty
- Float level too low
- Air vent tube clogged
- Advanced ignition timing
- Intake air leak
- Worn crankshaft seal (alternator side)

Rich Mixture

- Choke valve in ON position
- Float valve faulty
- Float level too high
- Air jets clogged
- Air filter element contaminated
- Flooded carburetor
- Worn crankshaft seal (clutch side)

Minor Carburetor Adjustment

(Idle Mixture and Idle Speed)

To adjust the idle speed, warm up the engine and push the choke/idle speed knob down to the off position. Turn the choke/idle speed knob clockwise to decrease engine speed, or counterclockwise to increase engine speed.

NOTE

- For a stable idle speed, turn the choke/idle speed knob at least 6 turns (36 clicks) counterclockwise from the fully seated position.

Idle mixture can be adjusted by turning the air screw; turning it in richens the mixture, while turning it out leans the mixture.

To adjust: turn the air screw in until it seats lightly, then back it out to the initial setting.

Standard: 2 turns out

Start the engine.

When the engine is warm enough to run without the choke, make fine adjustments in the air screw setting until the engine revs ou smoothly.

Test the adjustment by accelerating away from a slow corner. Readjust as necessary.

A combination of a slightly rich mixture and an idle speed that's set too high may lead to plug fouling when shutting off for tight sections of the track.

Reduce idle speed of this occurs.

Major Carburetor Adjustment

(For Temperature and Altitude)

1) Check that the carburetor is adjusted to the standard settings.

NOTE

- For the following recommendations to be accurate, you must use these standard settings as a baseline.
- The standard settings are ideal for a motorcycle with an unmodified engine running under the following conditions:

- 32-to-1 premix ratio with Honda HP2 2-Stroke Oil or equivalent.
- Altitude—sea level.
- Temperature—20°C (68°F)

CAUTION

- If you are using a different premix ratio or engine is modified, you must adjust the mixture accordingly to prevent engine damage.

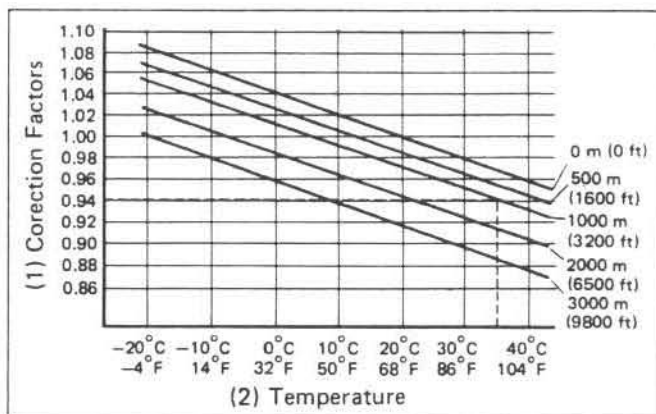
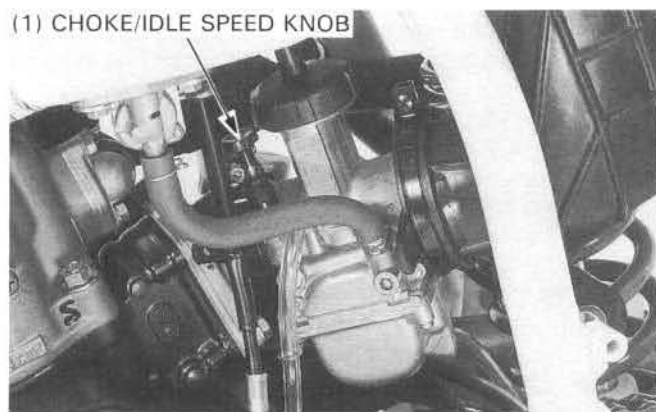
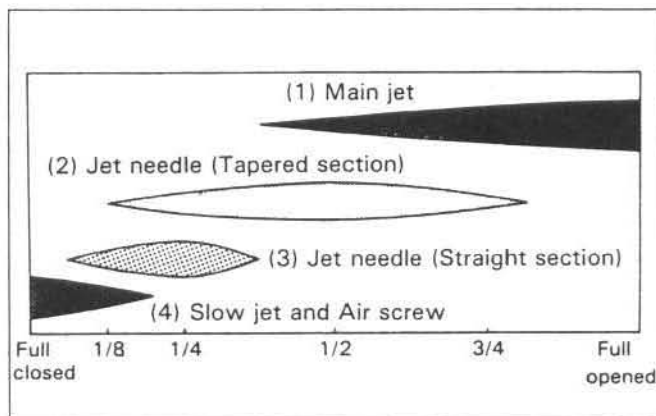

Fuel System

2) Find your correction factor on the chart.

Example: 1,000 meters (3,200 ft) altitude with an air temperature of 35°C (95°F). The correction factor is 0.94.

3) Using your correction factor, select the correct main and slow jets.

EXAMPLE: For a correction factor of 0.94, multiply the jet size by that number.

Main jet #172 x 0.94 = #162

Slow jet #58 x 0.94 = #55

4) Find your factor on the Jet Needle/Air Screw Chart and adjust the jet needle clip position and air screw opening as shown.

EXAMPLE: For a correction factor of 0.94, raise the needle clip one position and turn out the air screw one extra turn.

Jet needle clip setting

3rd groove from top minus 1 – 2nd groove from top.

Air screw opening

2 + 1 turn = 3 turns out.

5) Start the engine and let it warm up for a few minutes. Adjust the idle speed, as necessary. Test ride the motorcycle. Does it perform poorly in any of the speed range? If so, make adjustments as required.

NOTE

- The correction factors will get you very close to the ideal jetting. However, because of differences in pressure and humidity, you may need to fine tune the carburetor for race day conditions.

• Just off idle:

Engine blubbers (rich) – turn out the air screw 1/4 turn.

Engine surges (lean) – turn in the air screw 1/4 turn.

NOTE

- The minimum to maximum range of air screw adjustments is 1 to 3 turns out. If you must exceed these limits, you need the next smallest slow jet or the next largest slow jet. Select the correct slow jet (page 1-21) and begin again from step 4.

• On the top end:

Engine blubbers (rich) – go to next smaller main jet.

Engine surges (lean) – go to next larger main jet.

CAUTION

- To prevent engine damage, always adjust the main jet (top end) before adjusting the jet needle (mid-range). Always jet one number on the rich side for safety.

• In the mid-range:

Engine blubbers (rich) – lower the jet needle by raising the needle clip one position.

Engine surges (lean) – raise the jet needle by lowering the needle clip one position.

6) Test ride again and readjust as required.

NOTE

- If you used the correction factors correctly, it shouldn't be necessary to adjust more than one increment, richer or leaner. If a very large adjustment is required, there may be something wrong elsewhere. Check for worn crankshaft seals, air leaks, blocked exhaust or fuel system, or a dirty air cleaner element.

CORRECTION FACTORS	1.06 or above	1.06–1.02	1.02–0.98	0.98–0.94	0.94 or below
JET NEEDLE CLIP POSITION	Lower clip 1 groove	STANDARD			Raise clip 1 groove
AIR SCREW OPENING	1 turn in	1/2 turn in	STANDARD	1/2 turn out	1 turn out

Tuning For Special Condition

Once you've adjusted the carburetor for temperature and altitude, it shouldn't need major readjustment unless the race conditions change drastically. Exclusive of the correction factors, there are some unique atmospheric or race day situations that may require additional adjustments. They are as follows:

- Main Jet**
- Go richer on the main jet, by one number. When: the track has a very long straightaway, steep climbs, a high percentage of sand, or the track is muddy.
 - Go leaner on the main jet, by one number, when: it is very humid or raining, or it is very hot above 45°C (113°F).
- Jet Needles**
- Under normal circumstances, the standard jet needle can be adjusted to fit most situations. However, a peculiar condition may require replacement of the standard jet needle. But before replacing the standard needle, complete all the carburetor adjustments (page 4-3 through 4-4). If mid-range performance is still not satisfactory, try one of the optional jet needles: See page 1-21.

Carburetor Removal/Disassembly

Removal

⚠ WARNING

- Gasoline is extremely flammable and is explosive under certain condition.

Turn the fuel valve OFF and disconnect the fuel line from the carburetor.

Turn the handlebar to the left fully.

Loosen the carburetor insulator clamp screw and connecting tube clamp screw, and turn the carburetor to the left.

Remove the carburetor top and pull out the throttle valve.

Remove the carburetor.

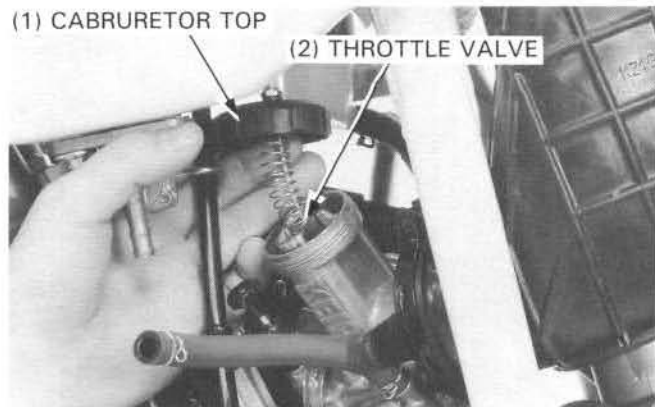
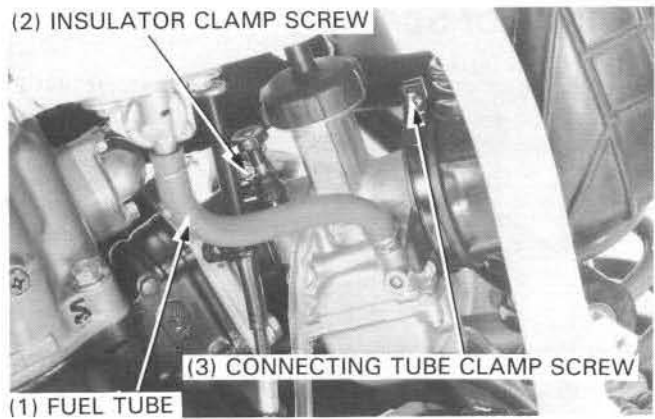

Disassembly

Remove the throttle cable from the cable holder.

Remove the throttle valve spring from the carburetor top.

Push down on the cable holder and turn it 90 degree. Remove the cable holder, set collar, spring and jet needle.

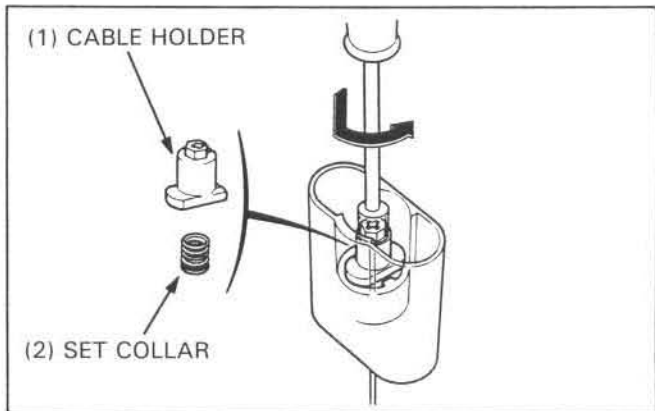

Remove the following:

- Float chamber
- Float pin
- Float
- Float valve

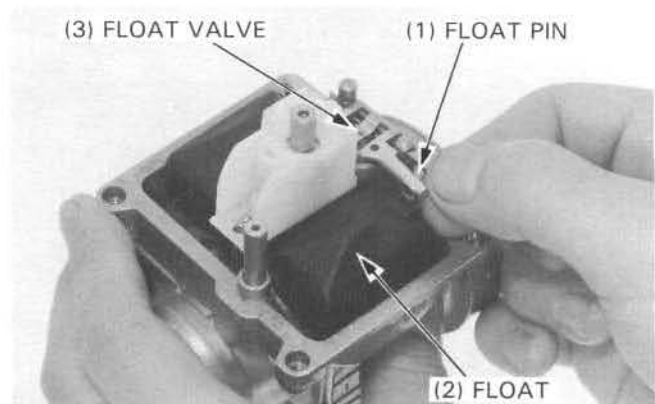

Remove the following:

- Main jet
- Baffle plate
- Slow jet

CAUTION

- Do not try to remove the jet block from the carburetor body.

NOTE

- Before removing the air screw, turn it in, counting the number of turns until it seats lightly.

- Air screw, spring, washer, O-ring

Unscrew the lock nut and remove the choke/idle speed knob.

Check the valve seat and needle for damage.

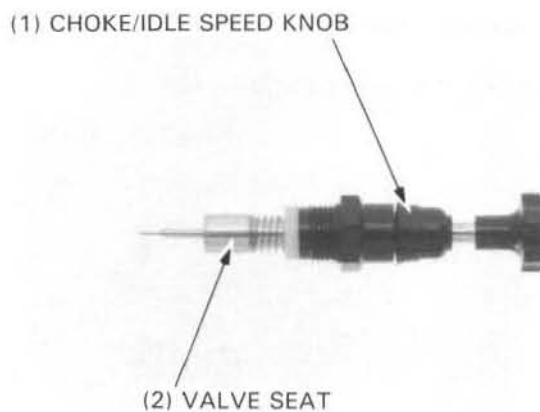
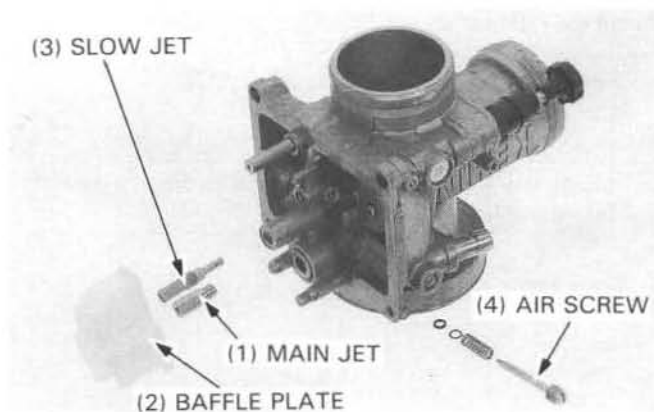

Carburetor Assembly/Installation

Assembly

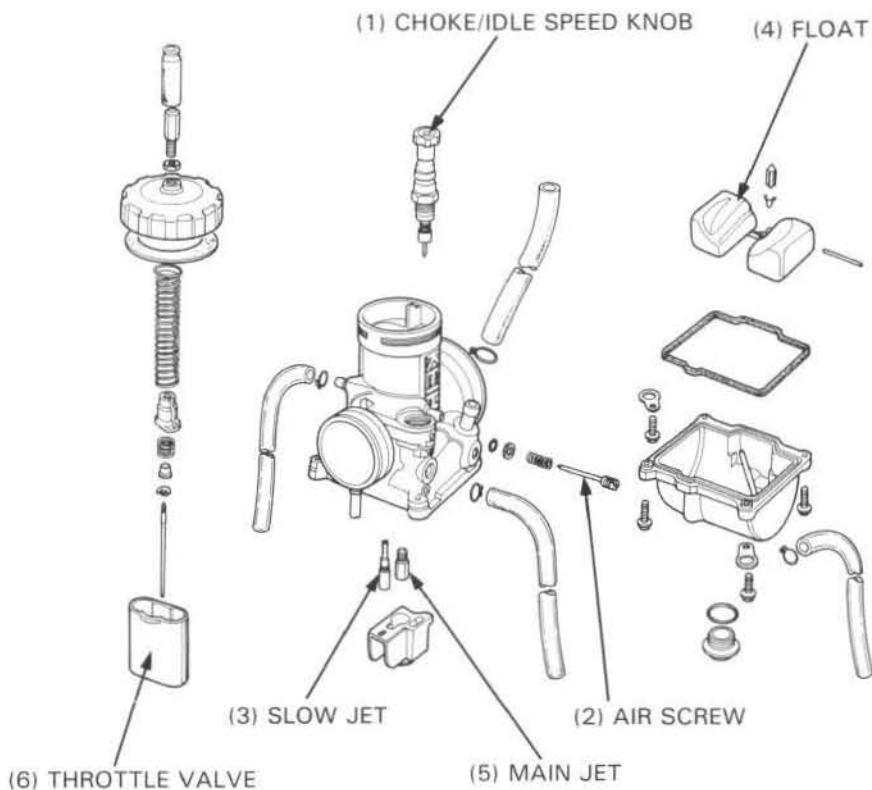

Fuel System

Install the following:

- Choke/idle screw knob
- O-ring, washer, spring, air screw

NOTE

- Install the air screw and return it to its original position as noted during removal.

- Slow jet
- Baffle plate
- Main jet

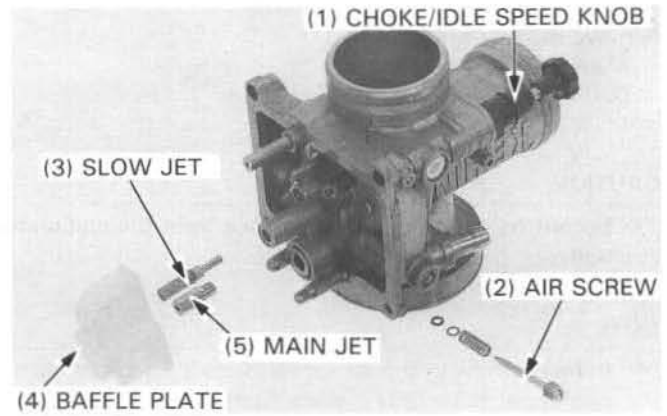

Install the float valve, float and float pin.

Measure the float level. (Specification; page 1-6)

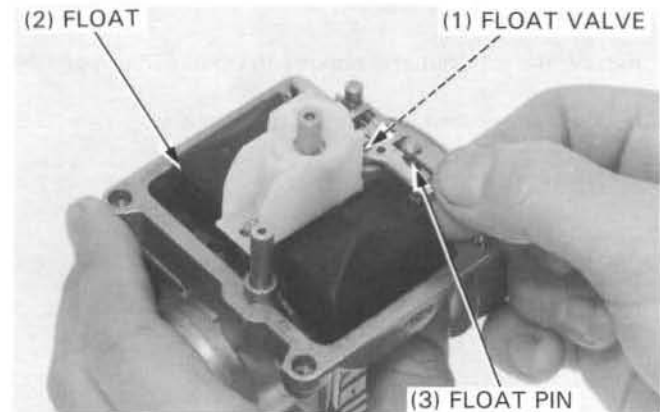

Install a new float chamber O-ring.
Install the float chamber and tighten the screws securely.



NOTE

- Install the air vent tube guide as shown.

Install the carburetor tubes as shown.

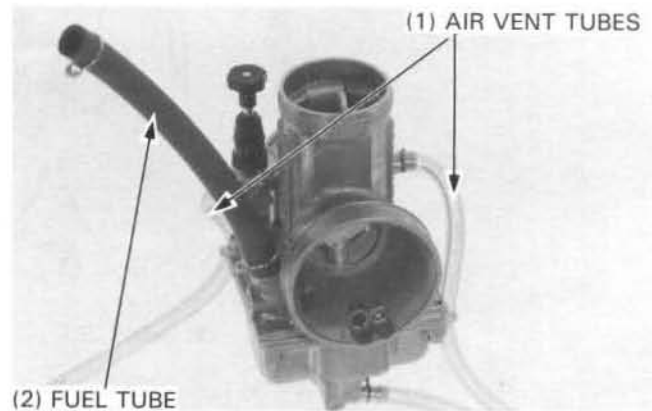

Install the needle clip on the jet needle.

Standard Position: 3rd groove

Assemble the set spring, collar and cable holder.

Install the jet needle into the throttle valve.

Install the set collar over the jet needle and install the cable holder.

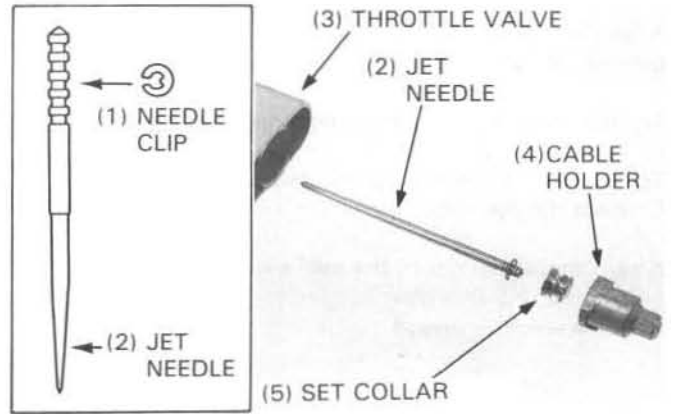

Push the cable holder in and turn it 90 degrees.

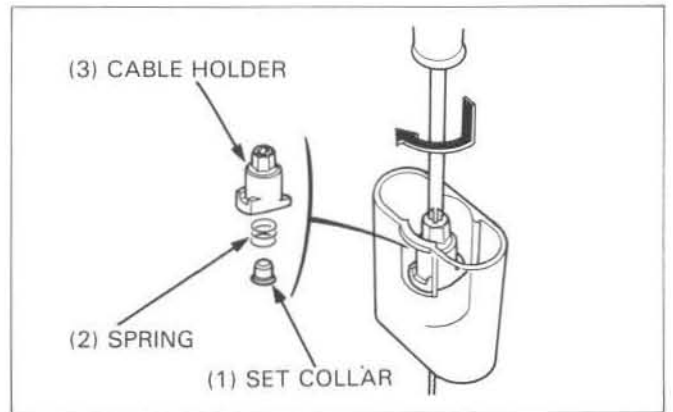

Assemble the throttle cable, carburetor top, rubber cap and throttle valve spring.

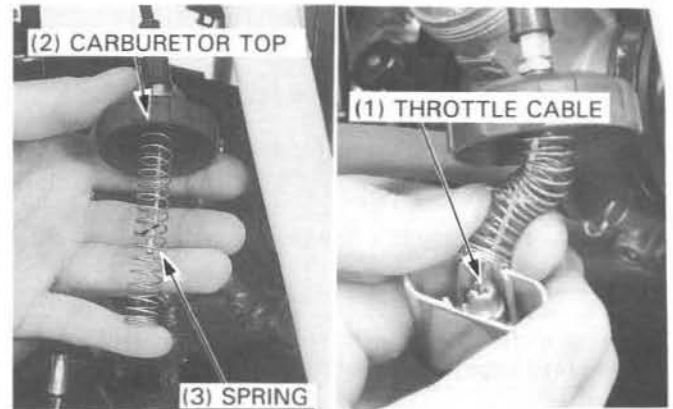

Installation

Loosely install the carburetor.

Move the carburetor to the left and slide the throttle valve into the carburetor body.

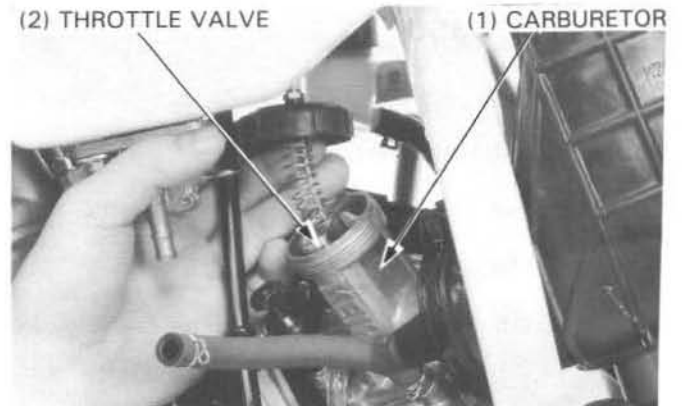

Fuel System

Align the lug on the carburetor with the groove of the carburetor insulator band.

Tighten the insulator and connecting tube clamp screws.

Tighten the carburetor top securely.
Connect the fuel tube.

After installation, check the following:

- Throttle grip free play
- Air screw adjustment

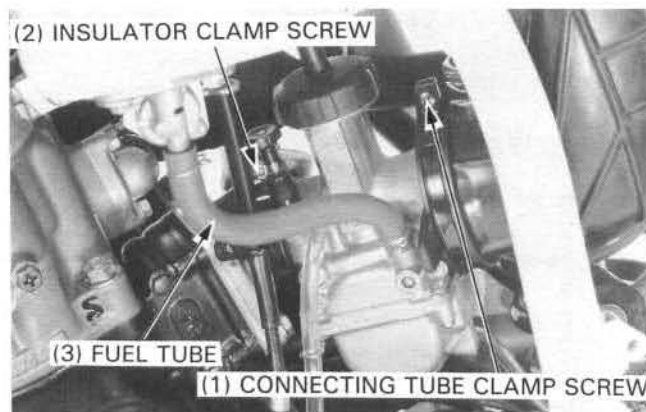

Reed Valve

Removal

Remove the carburetor (page 4-6).

Remove the following:

- Insulator mounting bolts
- Insulator
- Reed valve
- Gasket

CAUTION

- Be sure to replace the reed valve as an assembly. Disassembling or bending the reed stopper can cause engine trouble.

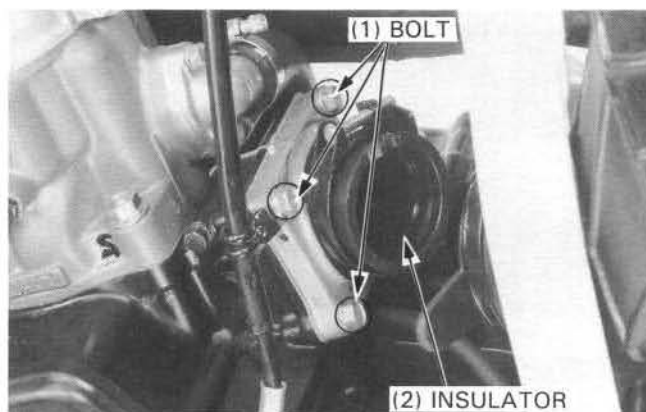

Installation

Check the insulator and O-ring for damage and replace them if necessary.

Reed valve installation is in the reverse order of removal.

NOTE

- After installation, check for secondary air leaks around the reed cage and insulator.

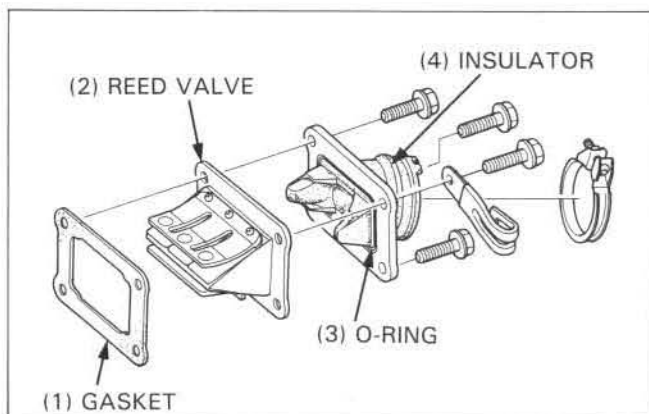

Air Filter Case

Removal

Remove the sub-frame (page 2-5).

Remove the air filter case mounting bolts and the air filter case.

For air filter element service, see page 3-6.

Check the carburetor connecting tube to be sure it is sealing properly.

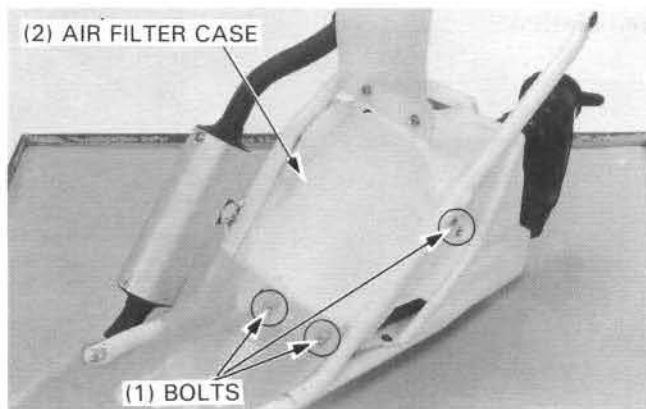

Installation

Air filter case installation is in the reverse order of removal.

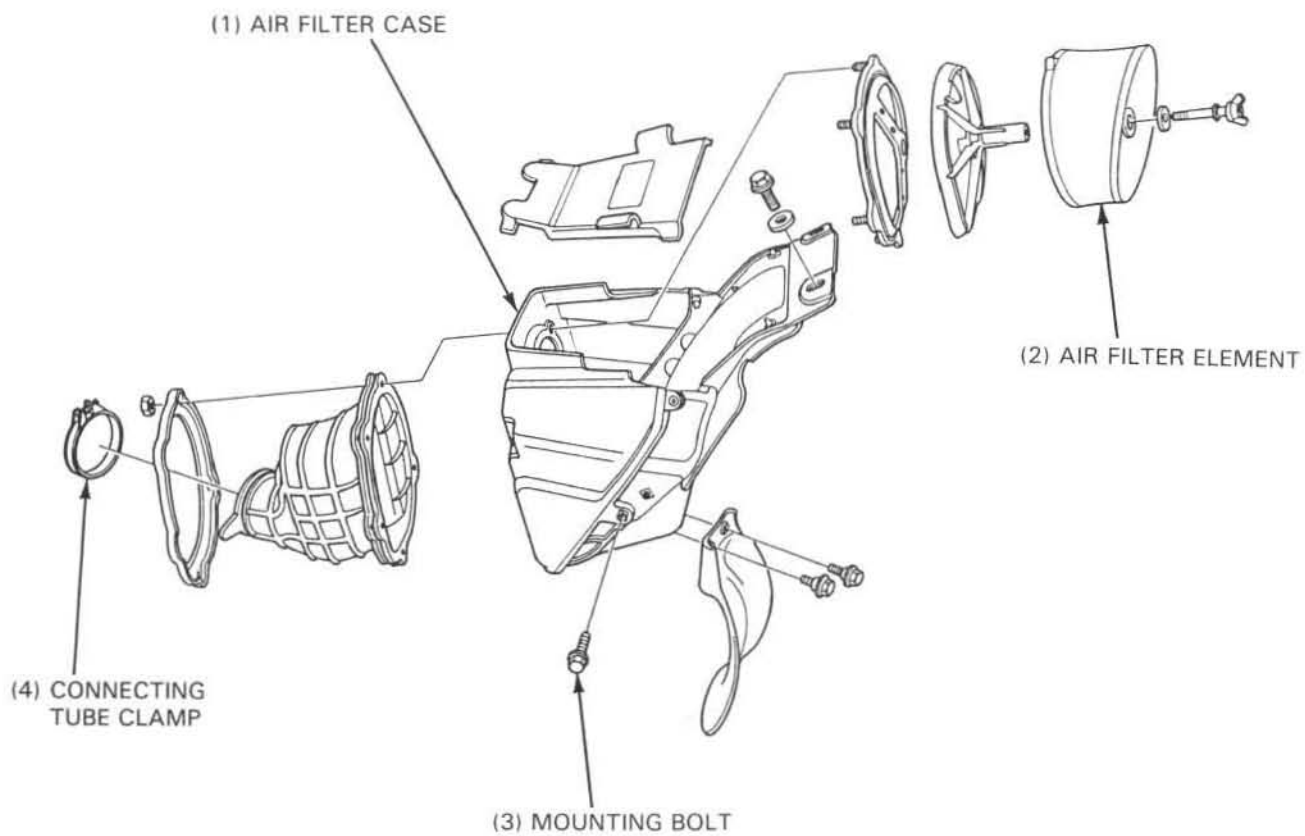

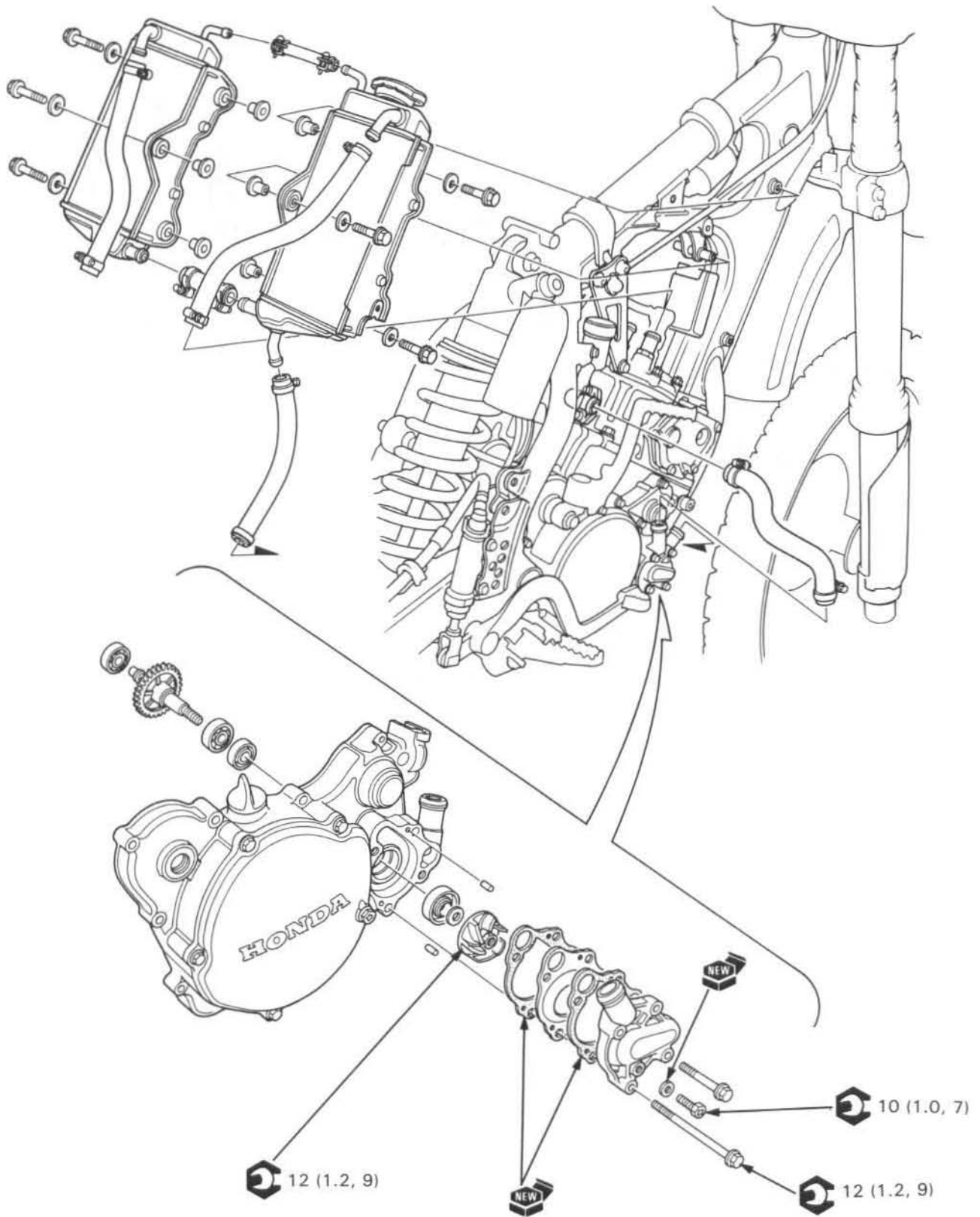

5. Cooling System

Service Information	5-1	Radiator	5-4
Troubleshooting	5-2	Water Pump	5-5
Coolant Replacement	5-3		

Service Information

General

▲ WARNING

- Wait until the engine is cool before slowly removing the radiator cap. Removing the cap while the engine is hot and the coolant is under pressure may cause serious scalding.
- Radiator coolant is toxic. Keep it away from eyes, mouth, skin and clothes.
 - If any coolant gets in your eyes, rinse them water and consult a doctor immediately.
 - If any coolant is swallowed, induce vomiting, gargle and consult a physician immediately.
 - If any coolant gets on your skin or clothes, rinse thoroughly with plenty of water.
- KEEP OUT OF REACH OF CHILDREN.

- To service the water pump seal, necessary to remove the right crankcase cover (Section 9).
- All cooling system services can be done with the engine in the frame.

Specifications

Item	Specifications
Recommended coolant	Use only a high quality ethylene glycol based anti-freeze containing corrosion inhibitors specially recommended for use in aluminum engine. A 50/50 mixture of anti-freeze and water is recommended for most operating conditions. (See anti-freeze container label for other mixture ratios)
Coolant capacity	750 cc (25.4 US oz, 26.3 Imp. oz)
Radiator cap relief pressure	110–140 kPa (1.1–1.4 kg/cm ² , 16–20 psi)

Torque Values

Water pump impeller	12 N·m (1.2 kg-m, 9 ft-lb)
Coolant drain bolt	10 N·m (1.0 kg-m, 7 ft-lb)
Water pump cover bolt	12 N·m (1.2 kg-m, 9 ft-lb)

Tools

Special

Water seal driver	07945–KA30000 or GN–AH–065–415 (U.S.A. only)
Bearing remover set, 12 mm	07936–1660001 – Not available in U.S.A.
– remover handle assembly	07936–1660101
– remover weight	07741–0010201 or 07936–3710200
Bearing remover, 7 mm	07931–KA30000
Bearing driver, 7 mm	07946–KA30100

Common

Driver	07749–0010000
Attachment, 24 x 26 mm	07746–0010700
Pilot, 12 mm	07746–0040200

Troubleshooting

Engine Temperature Too High

- Faulty radiator cap
- Insufficient coolant
- Passages blocked in radiator, hoses or water jacket

Coolant Leaks

- Faulty water pump oil seal
- Deteriorated water seal

Coolant Replacement

▲ WARNING

- Wait until the engine is cool before servicing the cooling system. Removing the radiator cap while the engine is hot and the coolant is under pressure may cause serious scalding.

Remove the radiator cap with the machine upright.

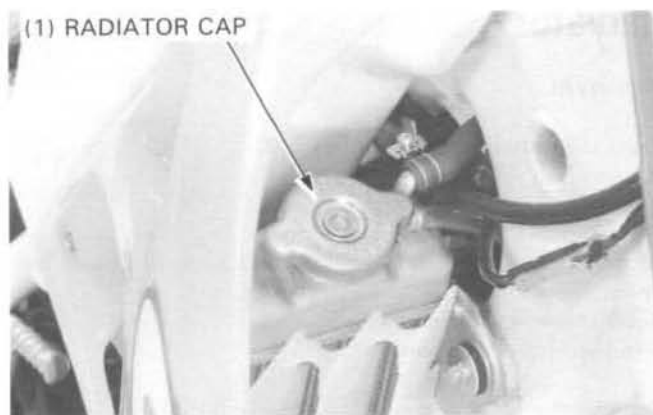

Remove the coolant drain bolts at the cylinder and water pump, and drain the coolant.



Check the drain bolt sealing washers are in good condition, then install and tighten the drain bolts to the specified torque.

Torque: 10 N·m (1.0 kg·m, 7 ft·lb)

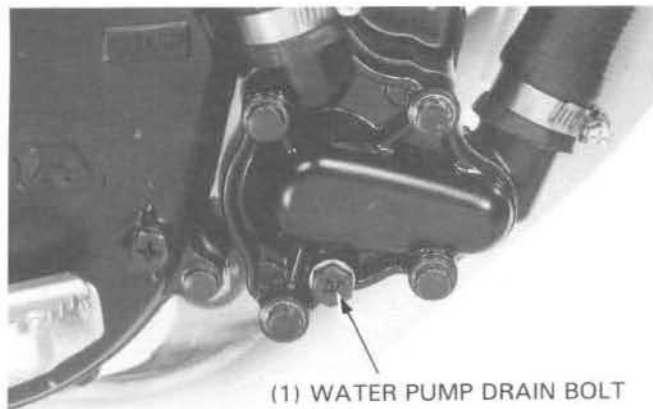

Add the recommended coolant mixture to the radiator filler neck (page 1-6).

Capacity: 750 cc (25.4 US oz, 26.3 Imp oz)

Lean the machine approximately 20° right and left several times to bleed air trapped in the cooling system. If the coolant level drops, add more coolant and repeat air bleeding procedure.

Install the radiator cap securely.



Radiator

Removal

Drain the radiator coolant (page 5-3).
Remove the radiator shroud and grill.

Remove the radiator upper joint hose.
Loosen the radiator hose clamp and remove the following hoses:

- radiator-to-cylinder head
- radiator-to-water pump

Remove the radiator mounting bolts and radiator.

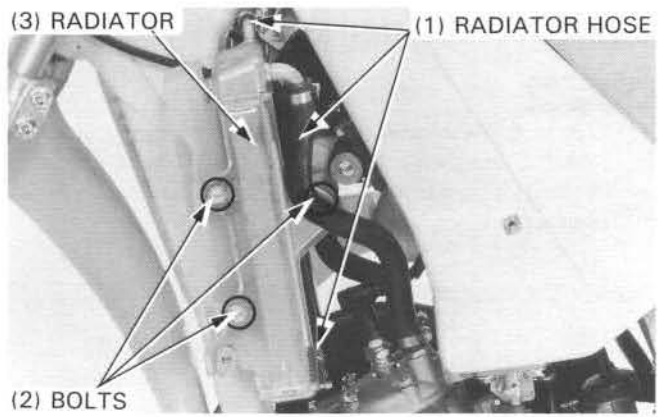

Installation

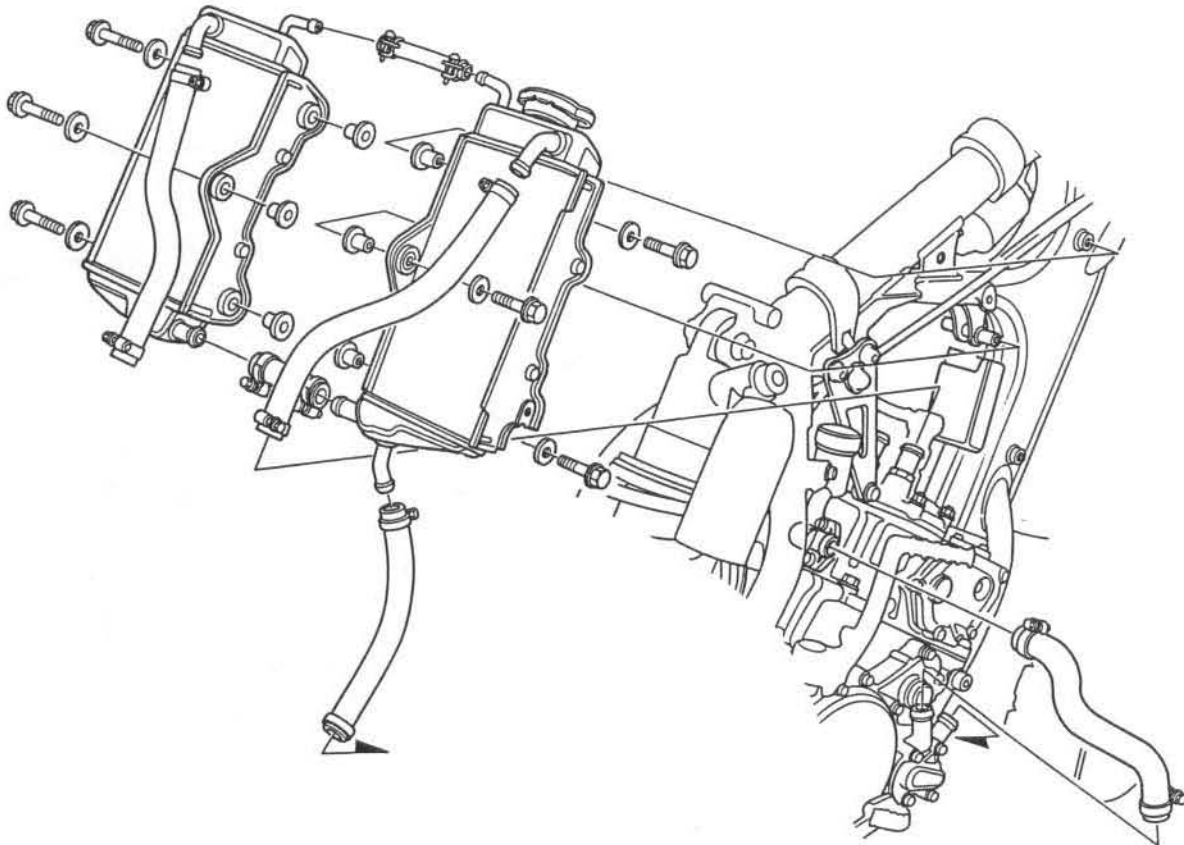

Installation is essentially the reverse order of removal.

Add the recommend coolant mixture up to the filler neck and bleed the air (page 5-3).

After installation, check the radiator and radiator hoses for leak.

NOTE

- Note the direction of the hose clamps.

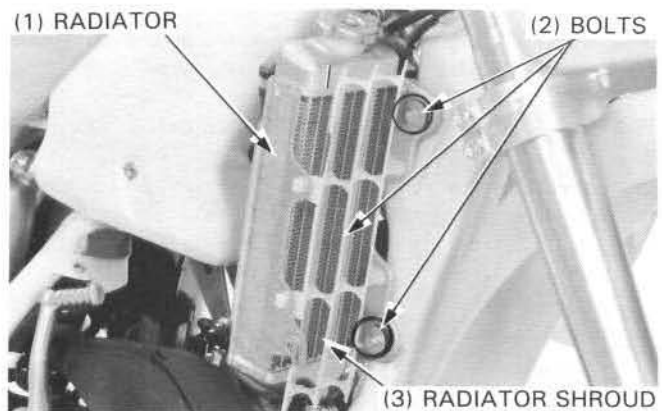

Water Pump

Water Seal Inspection

Check the inspection hole for signs of coolant leakage. Replace the water seal if coolant is leaking (page 5-6).

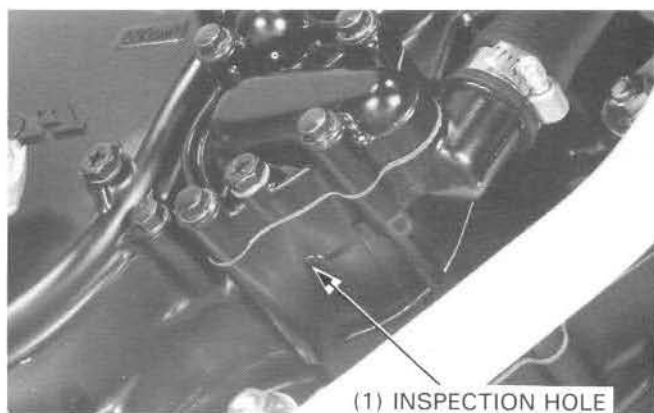

Desassembly

Drain the radiator coolant (page 5-3).

Remove the following:

- Water pump cover bolts and cover
- Outer gasket
- Plate
- Dowel pin

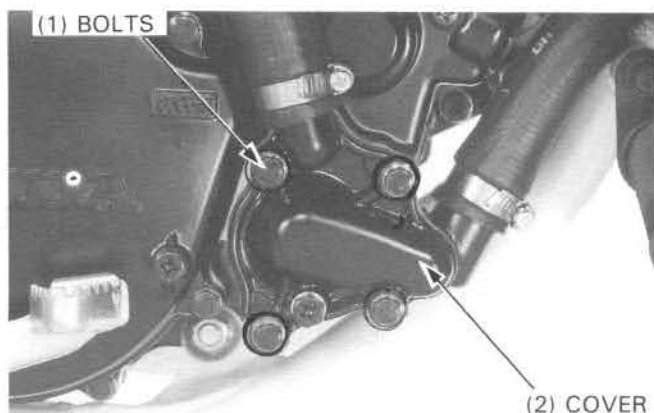

Remove the following:

- Inner gasket
- Impeller and plain washer
- Right crankcase cover (page 9-2)
- Water pump shaft from the right crankcase cover

Check the water pump shaft and gear to be sure they are not bent or damaged.

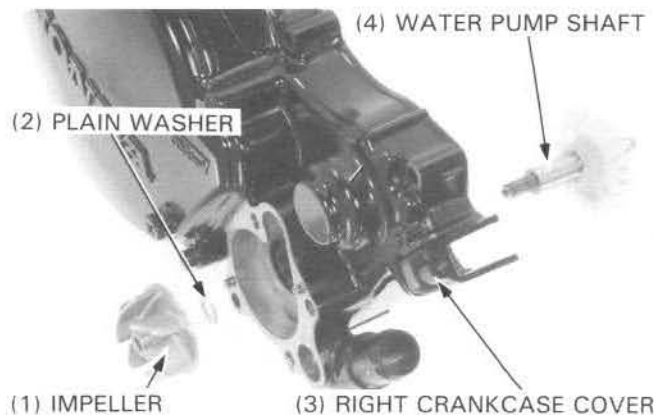

Bearing Replacemen

Right Crankcase Cover Side:

Remove the bearing using the special tools.

 S. TOOL

Bearing remover set, 12 mm

- Bearing remover handle
- Remover weight

07936-1660001
– Not available in U.S.A.
07936-1660101
07741-0010201 or
07936-3710200

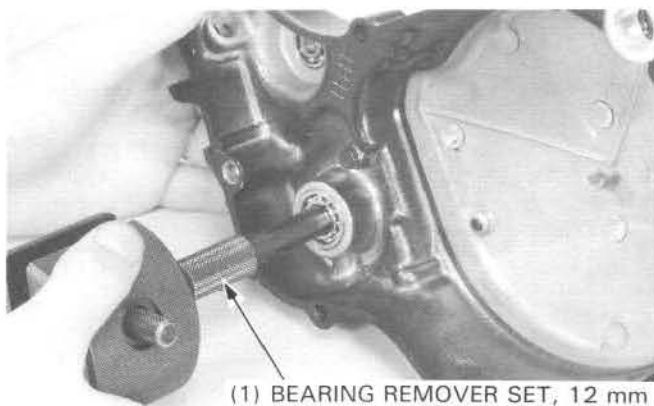

Cooling System

Drive in the new bearing into the right crankcase cover.

S. TOOL

Driver	07749-0010000
Attachment, 24 x 26 mm	07746-0010700
Pilot, 12 mm	07746-0040200

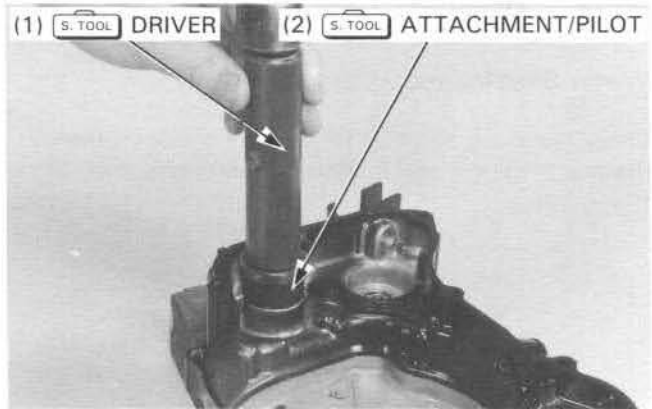

Right Crankcase Side:

Remove the bearing using the special tool as shown.

S. TOOL

Bearing remover, 7 mm	07931-KA30000
-----------------------	---------------

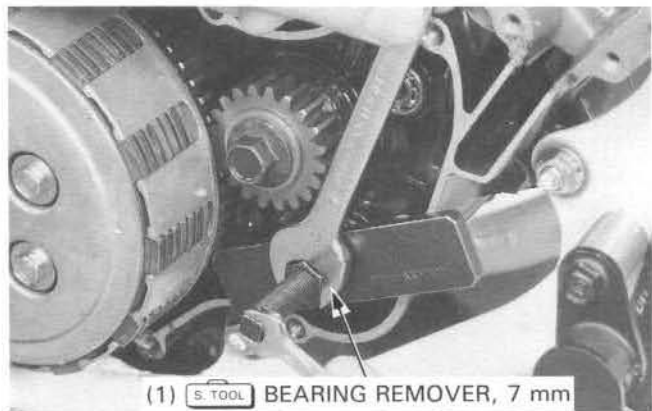

Drive in the new bearing into the right crankcase.

S. TOOL

Bearing driver, 7 mm	07946-KA30100
----------------------	---------------

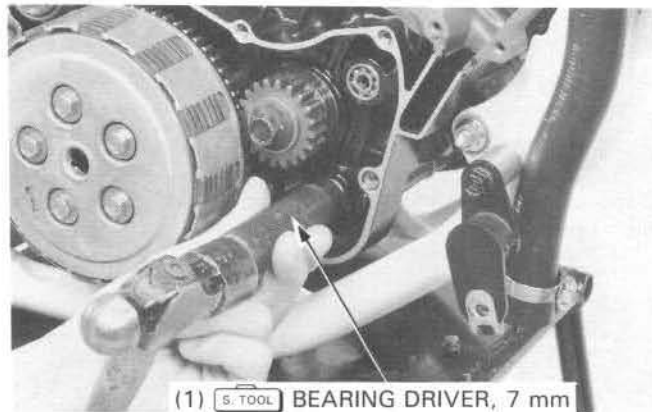

Water Seal Replacement

Remove the water pump bearing from the right crankcase cover (page 5-5).

Remove the oil seal.

Drive out the worn or damaged water seal from the right crankcase cover.



Install the water seal driver into the right crankcase cover as shown.

Drive in the new water seal.

S. TOOL

Water seal driver
Mechanical seal installer

07945-KA30000 or
GN-AH-065-415
(U.S.A. only)

NOTE

- Do not damage the water seal lips.

Install a new bearing and oil seal.

Assembly

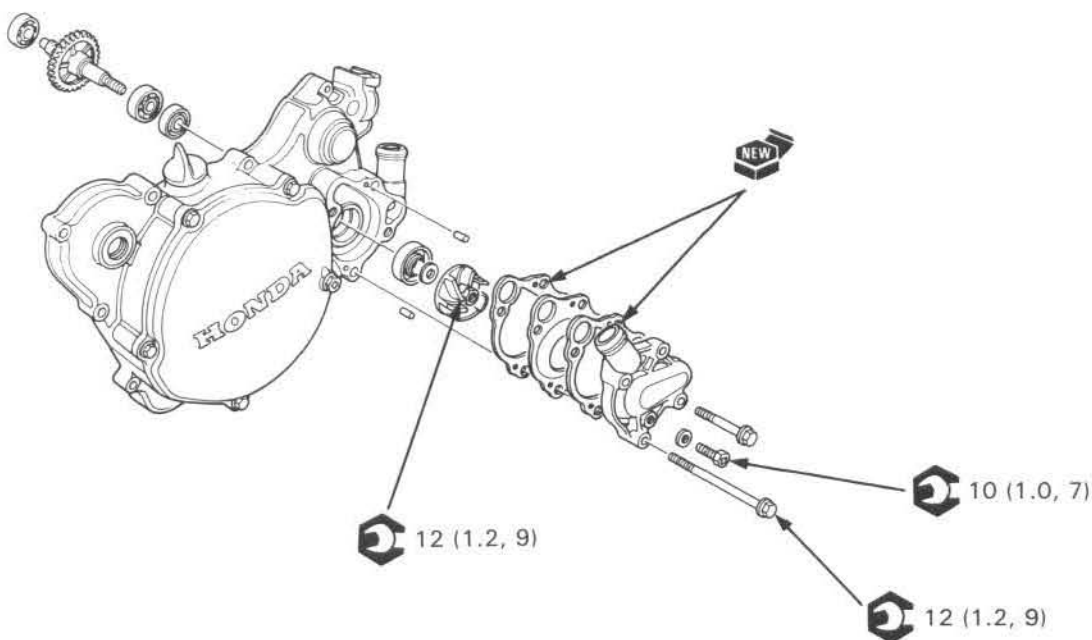

Install the following:

- Water pump shaft/gear into the right crankcase cover
- Right crankcase cover (page 9-2)

Install the plain washer and impeller on the water pump shaft, then tighten the impeller to the specified torque.

Torque: 12 N·m (1.2 kg-m, 9 ft-lb)

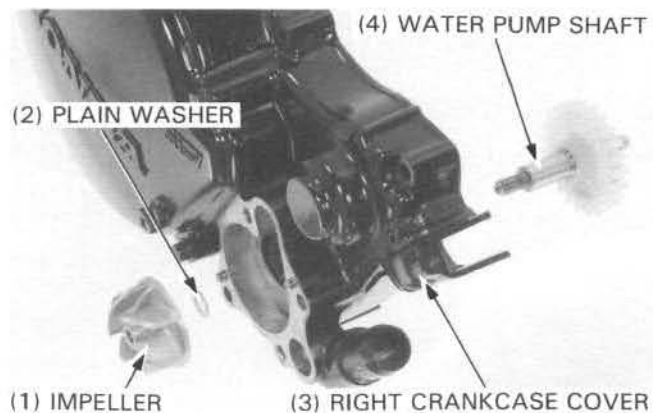

Cooling System

Install the dowel pins and new inner gasket.

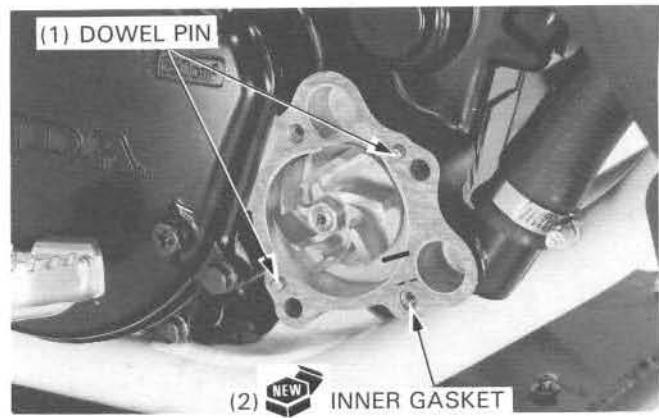

Install the plate.
Install the new outer gasket onto the water pump cover.

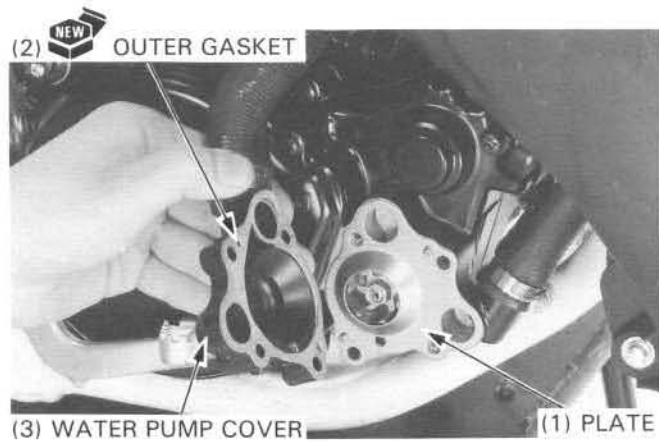

Install the water pump cover and tighten the mounting bolts to the specified torque.

Torque: 12 N·m (1.2 kg-m, 9 ft-lb)

Add the recommend coolant mixture up to the filler neck and bleed the air (page 5-3).

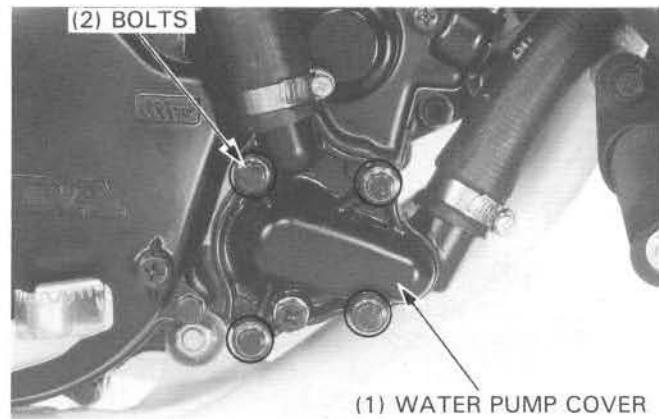

MEMO

RIDE RED

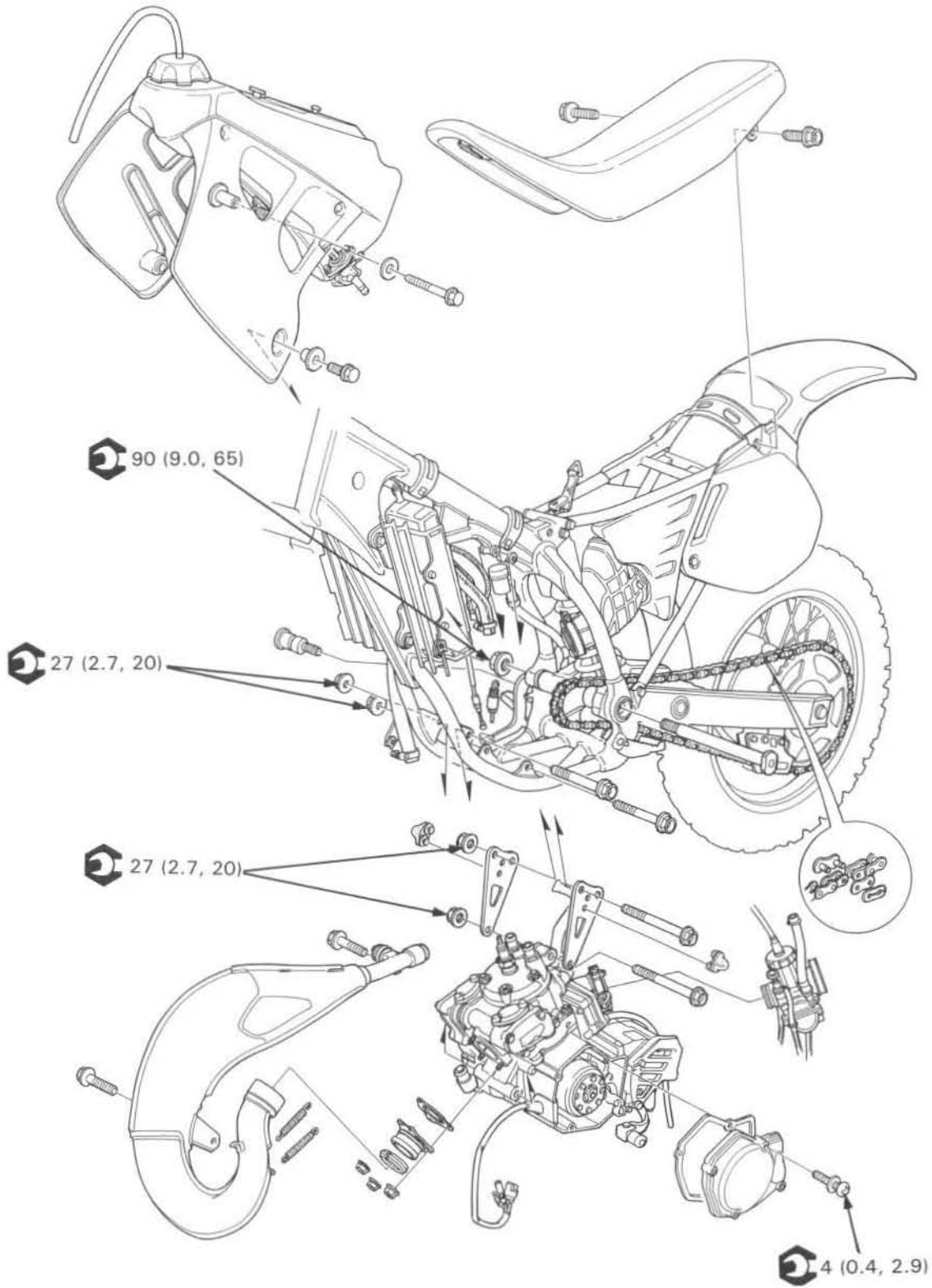

6. Engine Removal/Installation

Service Information	6-1	Engine Installation	6-3
Engine Removal	6-2		

Service Information

General

- During removal and installation, place a work stand or box under the engine to support the motorcycle securely.
- The following components can be serviced with the engine in the frame.
 - Alternator (Section 14)
 - Clutch/gearshift linkage (Section 9)
 - Cylinder head/cylinder/piston (Section 7)
 - H.P.P. system (Section 8)
- The following components require engine removal for service.
 - Crankshaft/transmission (Section 10)
 - Shift forks/shift drum (Section 10)

Specifications

Item		Specifications
Engine dry weight		17.6 kg (38.8 lbs)
Recommended transmission oil		Honda GN4 4-Stroke Oil or equivalent SAE 10 W-40, API service classification: SF or SG
Transmission oil capacity	At draining	0.57 liter (0.60 US qt, 0.50 Imp qt)
	At disassembly	0.65 liter (0.69 US qt, 0.57 Imp qt)
Coolant capacity		750 cc (25.4 US oz, 26.3 Imp oz)

Torque Values

Engine mounting bolt	27 N·m (2.7 kg-m, 20 ft-lb)
Engine hanger plate bolt	27 N·m (2.7 kg-m, 20 ft-lb)
Swingarm pivot bolt	90 N·m (9.0 kg-m, 65 ft-lb)
Sub-frame mounting bolt	27 N·m (2.7 kg-m, 20 ft-lb)
Alternator cover screw	4 N·m (0.4 kg-m, 2.9 ft-lb)

Engine Removal

Drain the transmission oil.
Drain the coolant (page 5-3).

Place a work stand or box under the engine.

Remove the following:

- Radiator hoses
- Brake pedal (page 13-14)
- Expansion chamber (page 2-4)

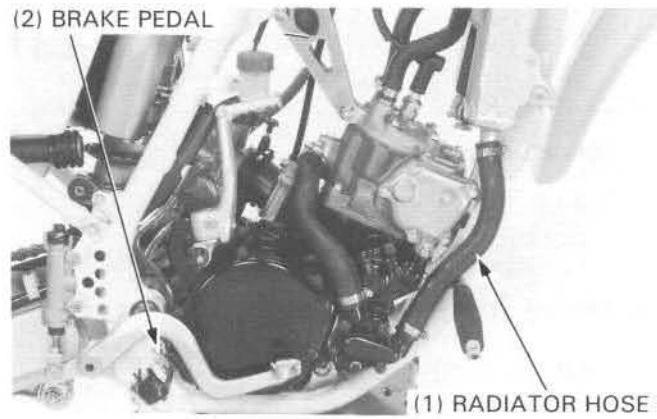

- Carburetor (page 4-6)
- Wire clamp
- Alternator wire connector
- Pulse generator wire connector
- Drive chain
- Spark plug cap
- Radiator hoses from cylinder head

Remove the alternator cover and disconnect the clutch cable.

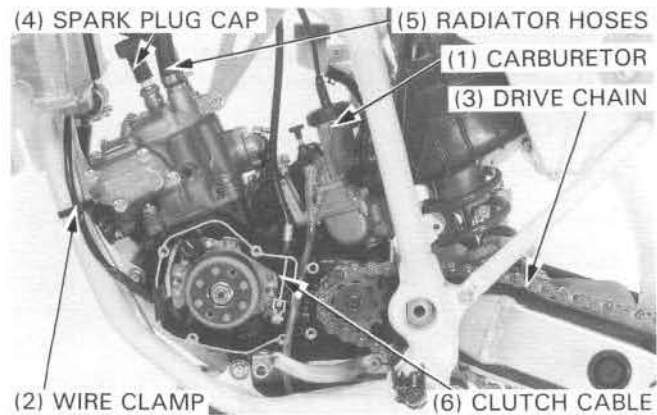

Remove the following:

- Engine upper bracket bolts and hanger bracket
- Engine mounting bolts
- Swingarm pivot bolt

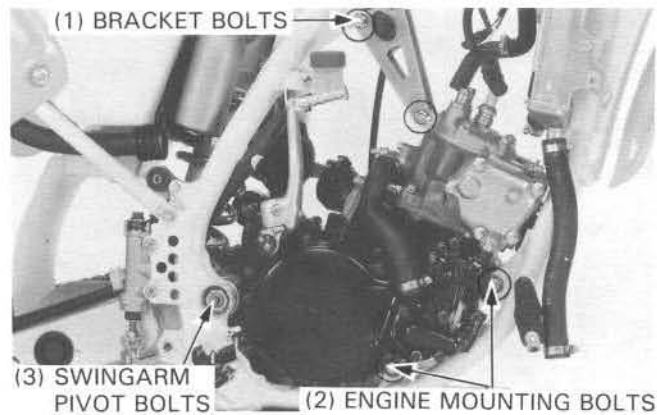

NOTE

- Note the direction of the engine mounting bolts and swingarm pivot bolt for reassembly (page 6-0).

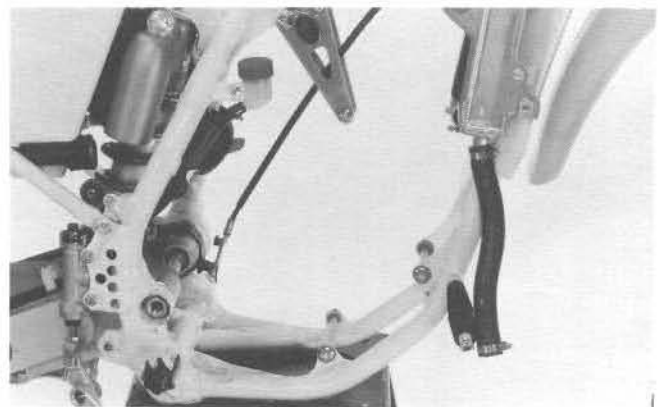

Engine Installation

Installation is in the reverse order of removal.

Torque:

- Swingarm pivot bolt: 90 N·m (9.0 kg-m, 65 ft-lb)
- Engine mounting bolt: 27 N·m (2.7 kg-m, 20 ft-lb)
- Engine upper bracket bolt: 27 N·m (2.7 kg-m, 20 ft-lb)

NOTE

- Route the wires and cables properly (page 1-14, through 1-18).

After installing the engine, perform the following inspections and adjustments:

- Transmission oil level
- Throttle grip free play adjustment
- Rear brake pedal height
- Drive chain slack
- Clutch lever free play

Check that exhaust gas is not leaking past the expansion chamber connection.

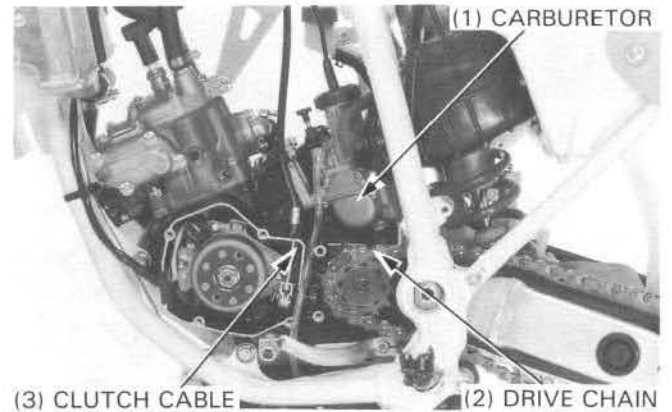
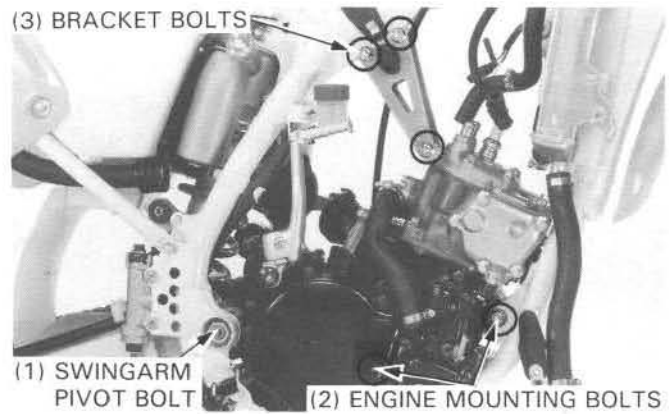

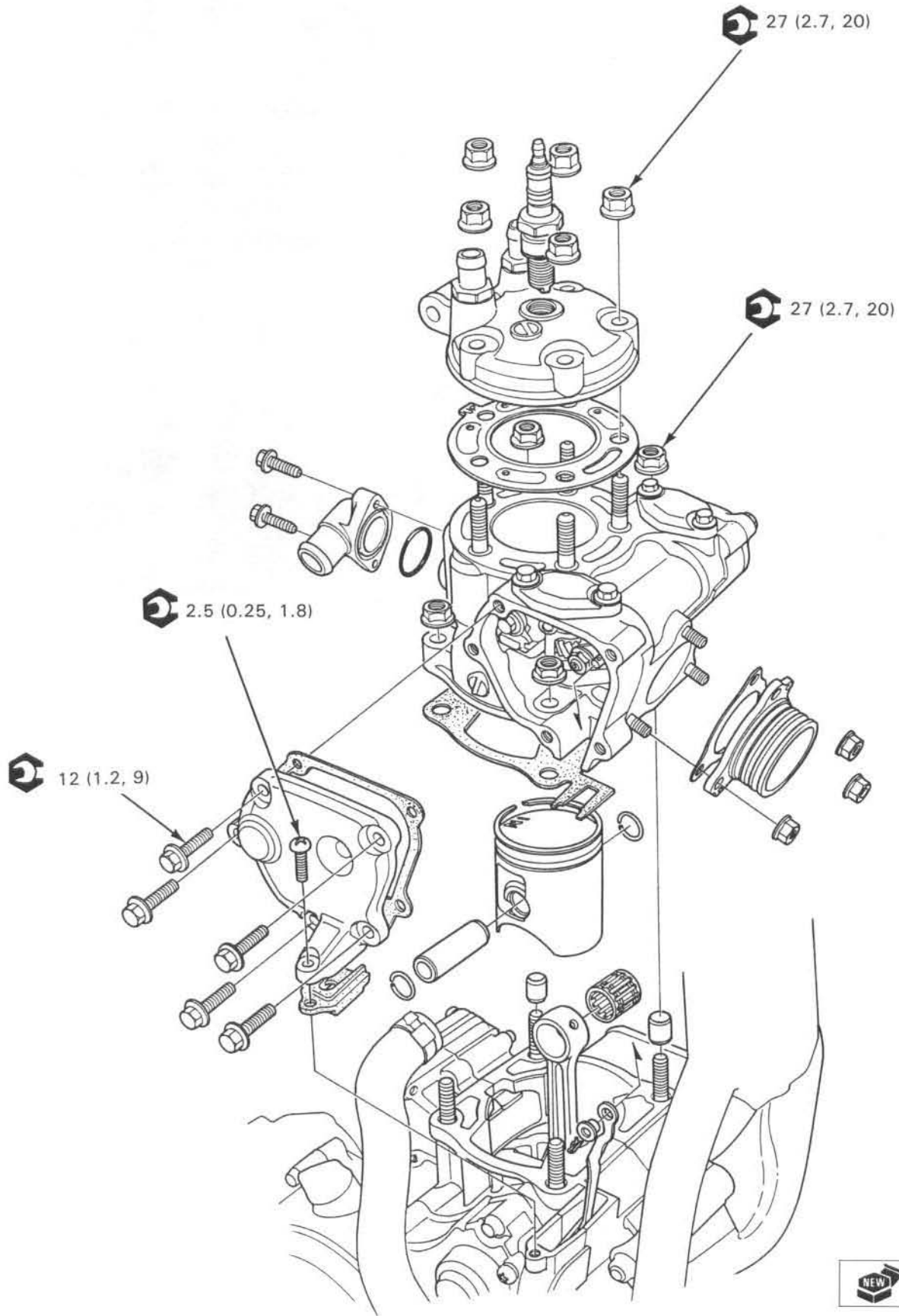

7. Cylinder Head/Cylinder/Piston

Service Information	7-1	Cylinder Head	7-3
Troubleshooting	7-2	Cylinder/Piston	7-5

Service Information

General

- This section covers maintenance of the cylinder head, cylinder and piston. These services can be done with the engine installed in the frame.
- Before disassembling, clean the engine thoroughly to keep dirt from entering the engine.
- Do not use a screwdriver to remove the cylinder head.
- Clean all parts before inspecting.
- Before assembling, apply clean recommended 2-stroke engine oil to all sliding surfaces.
- Under racing condition, the piston and piston ring should be replaced after 7.5 hours of running. And the piston pin and connecting rod small end bearing should be replaced after 22.5 hours of running.
- Refer to section 4 for reed valve servicing.
- Refer to section 8 for H.P.P. system decarbonizing, disassembly and assembly.
- The cylinders and pistons are select fitted. Use new cylinders and pistons with the same I.D. and O.D. codes when replacing the cylinder and/or piston.

Specifications

Unit: mm (in)

Item		Specification	Service Limit
Cylinder head warpage		—	0.05 (0.002)
Cylinder	I.D.	A	53.976—53.983 (2.1250—2.1253)
		B	53.968—53.976 (2.1247—2.1250)
	Taper	—	0.05 (0.002)
	Out of round	—	0.05 (0.002)
	Warpage across top	—	0.05 (0.002)
Piston, piston pin, piston ring	O.D.	A	53.933—53.940 (2.1233—2.1236)
		B	53.925—53.933 (2.1230—2.1233)
	Piston pin bore	15.002—15.008 (0.5906—0.5909)	15.022 (0.5914)
	Piston pin O.D.	14.994—15.000 (0.5903—0.5906)	14.980 (0.5898)
	Piston-to-piston pin clearance	0.002—0.014 (0.0001—0.0006)	0.02 (0.001)
	Piston ring-to-ring groove clearance	0.045—0.080 (0.0018—0.0031)	0.09 (0.004)
Piston ring end gap		0.40—0.55 (0.016—0.022)	0.65 (0.026)
Cylinder-to-piston clearance		0.035—0.050 (0.0014—0.0020)	0.07 (0.003)
Connecting rod small end I.D.		19.002—19.014 (0.7481—0.7486)	19.022 (0.7489)

Torque Values

Cylinder head nut	27 N·m (2.7 kg-m, 20 ft-lb)
Cylinder mounting nut	27 N·m (2.7 kg-m, 20 ft-lb)
Cylinder stud	12 N·m (1.2 kg-m, 9 ft-lb) Apply a locking agent
Engine hanger bracket bolt	27 N·m (2.7 kg-m, 20 ft-lb)
H.P.P. valve cover bolt	12 N·m (1.2 kg-m, 9 ft-lb)
H.P.P. valve cover screw	2.5 N·m (0.25 kg-m, 1.8 ft-lb)
Cylinder upper cover bolt	12 N·m (1.2 kg-m, 9 ft-lb)
H.P.P. valve guide bolt	9 N·m (0.9 kg-m, 6.5 ft-lb)
H.P.P. pinion holder socket bolt	5.5 N·m (0.55 kg-m, 4.0 ft-lb)

Troubleshooting

Compression Too Low, Hard Starting Or Poor Performance At Low Speed

- Blown cylinder head gasket
- Loose spark plug
- Worn, stuck or broken piston ring
- Worn or damaged cylinder and piston
- Faulty reed valve
- Worn crankshaft seals

Compression Too High, Overheating Or Knocking

- Excessive carbon build-up in combustion chamber or on top of piston

Abnormal Noise — Piston

- Worn or cracked piston
- Worn cylinder and piston
- Worn piston pin or piston pin hole
- Worn connecting rod small end bearing

Abnormal Noise — Piston Ring

- Worn, stuck or broken piston ring
- Worn or damaged cylinder

Contaminated Coolant

- Leaking cylinder head gasket

Cylinder Head

Removal

Drain the radiator coolant (page 5-3).
Remove the seat and fuel tank (page 2-2, 2-3).

⚠ WARNING

- Gasoline is extremely flammable and is explosive under certain condition.

Remove the expansion chamber (page 2-4).

Loosen the radiator hose clamps and remove the radiator hoses from the cylinder head.

Remove the spark plug cap and spark plug.

Remove the engine upper hanger plate bolts and hanger brackets.

Remove the five cylinder head flange nuts.
Remove the cylinder head.

CAUTION

- To avoid warping the cylinder head, use a crisscross pattern to loosen each nut about 1/4 turn, then remove the nuts.

Remove the cylinder head gasket.

Inspection

Clean the head gasket surface of any gasket material.
Remove the carbon deposits from the combustion chamber.

CAUTION

- Use care not to scratch the combustion chamber or the head gasket surface.

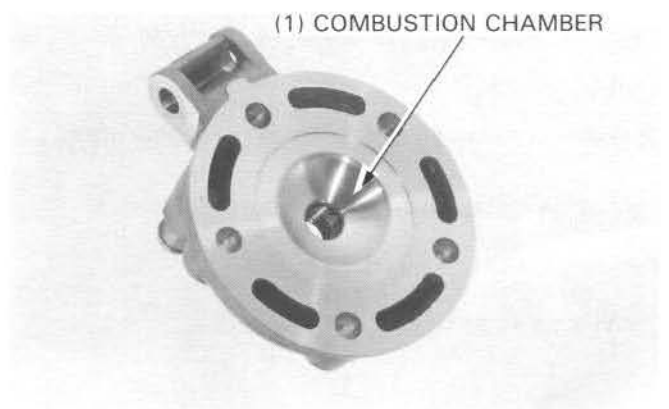
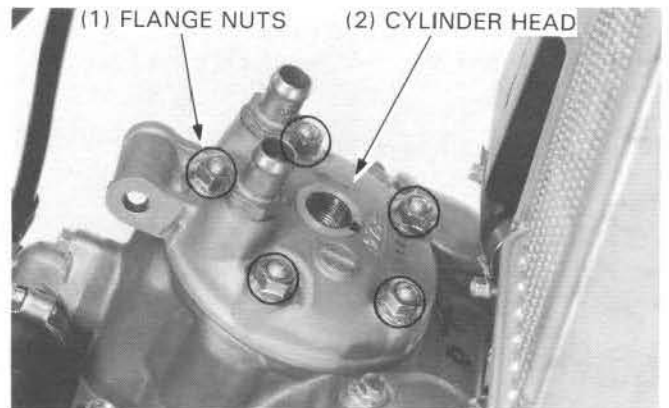
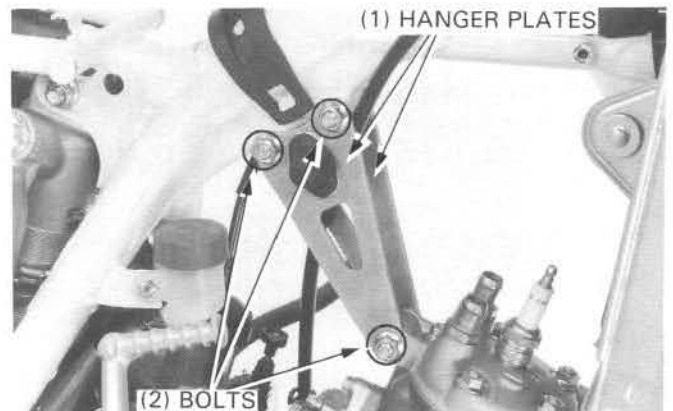
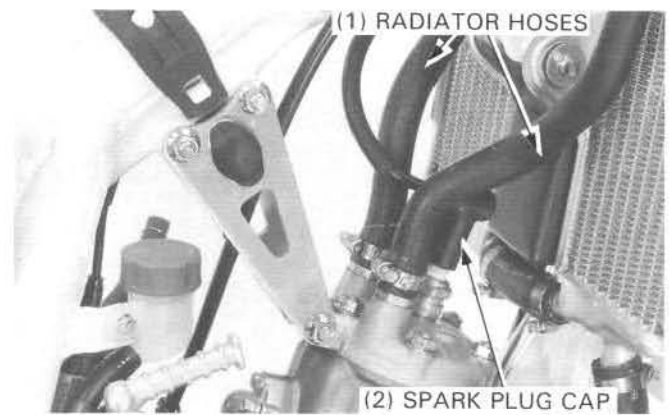

Cylinder Head/Cylinder/Piston

Check the cylinder head for warpage in diagonal directions with a straight edge and a feeler gauge.

Service Limit: 0.05 mm (0.002 in)

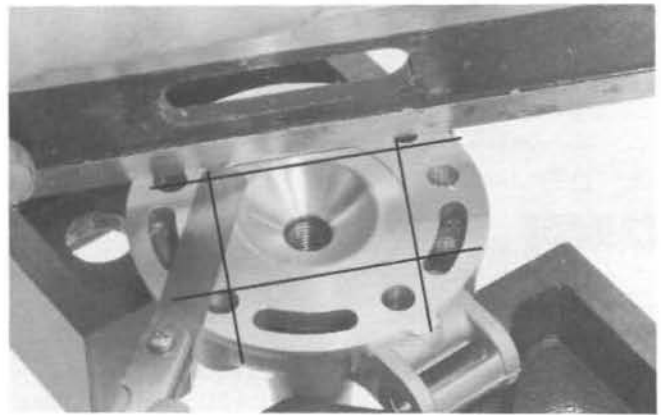

Installation

Install the new cylinder head gasket with the "UP" mark facing up.



Place the cylinder head on the cylinder. Install the five cylinder head flange nuts and tighten to the specified torque.

Torque: 27 N·m (2.7 kg-m, 20 ft-lb)

NOTE

- Tighten the nuts in a crisscross pattern in 2 or 3 steps.

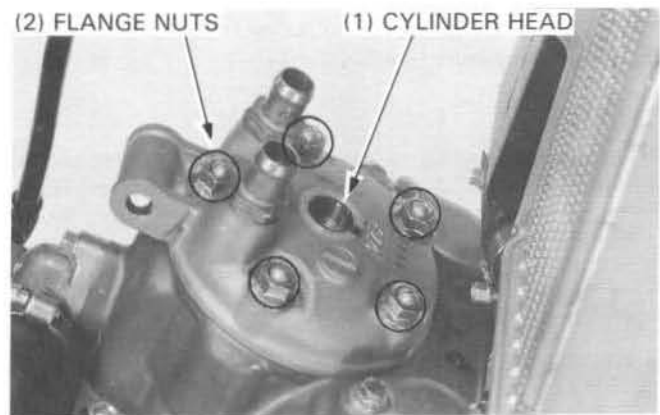

Install the engine upper hanger brackets and bolts.

NOTE

- Route the clutch cable between the hanger plates.

Tighten the mounting bolts to the specified torque.

Torque: 27 N·m (2.7 kg-m, 20 ft-lb)

Install the fuel tank guard rubbers.

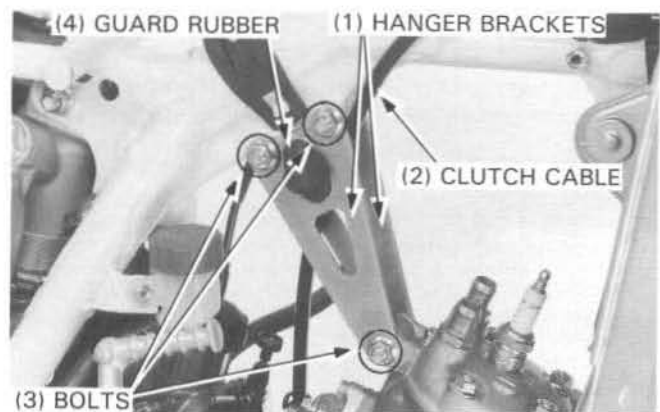

Install the spark plug and plug cap.

Connect the radiator hoses to the cylinder head.

NOTE

- Note the direction of the hose clamps.

Add the recommend coolant mixture into the radiator up to the correct level (page 5-3).

Install the following:

- Expansion chamber (page 2-4)
- Fuel tank (page 2-3)

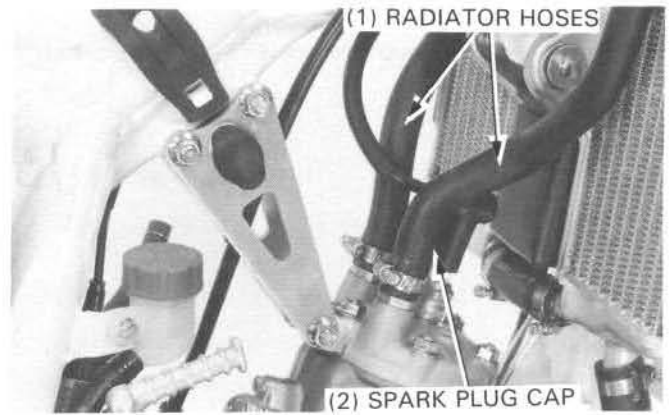

Cylinder/Piston

Removal

Remove the cylinder head (page 7-3).

Loosen the water hose clamp screws at the cylinder and remove the hose.

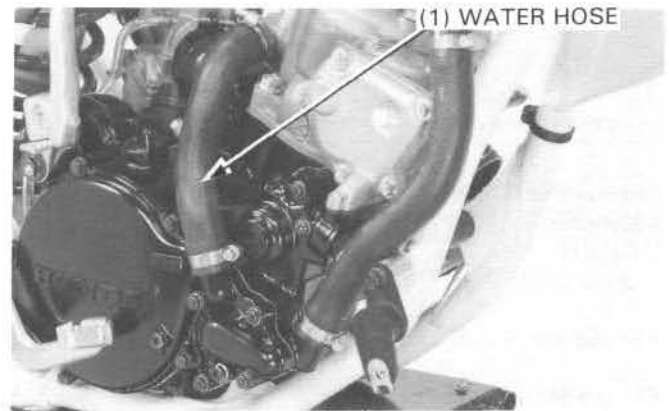

Remove the two right radiator mounting bolts and loosen the upper mounting bolt as shown.

Loosen the radiator lower joint hose clamp screws and remove the lower joint hose, then swing the right radiator forward.

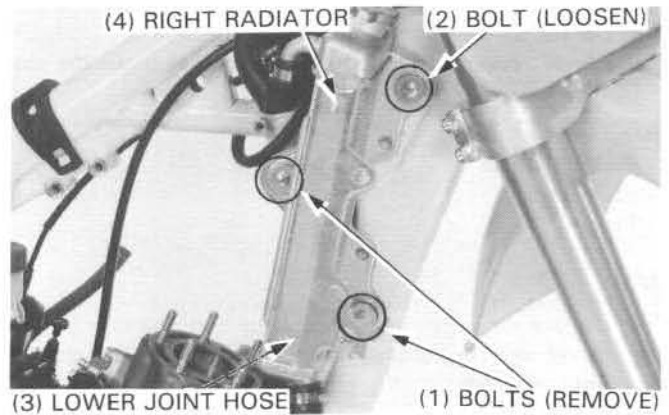

Remove the following:

- Bolts and screw
- Right exhaust valve cover
- Gasket and grommet
- H.P.P. valve rod

NOTE

- Be careful not to drop the B-clip and collar into the right crankcase cover.
- If cylinder replacement is required, remove the H.P.P. system.

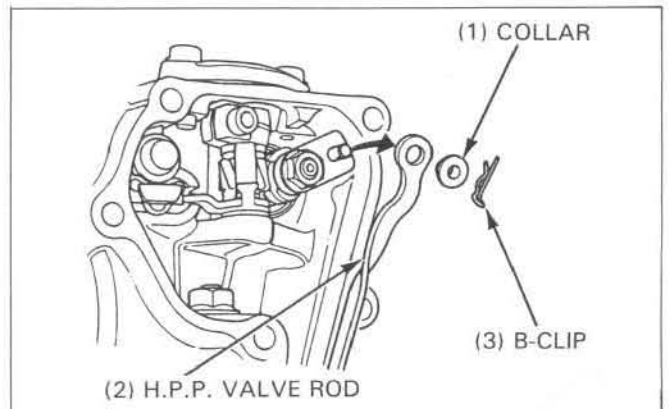

Cylinder Head/Cylinder/Piston

Remove the alternator cover (page 14-6).
Rotate the flywheel counterclockwise until the piston is at TDC.

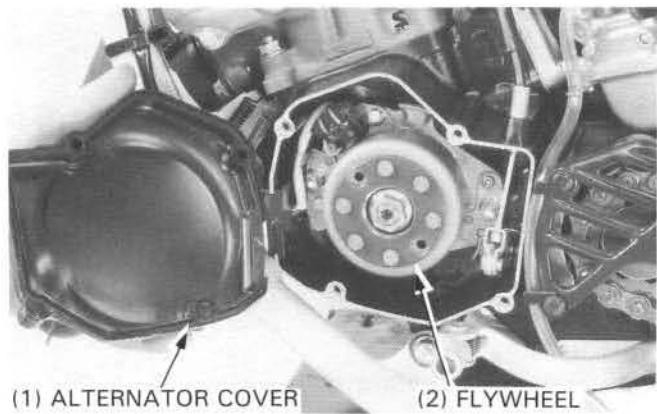

Remove the four cylinder mounting flange nuts.

NOTE

- Loosen the nuts in a crisscross pattern in 2 or 3 steps.

Remove the following:

- Cylinder
- Gasket
- Dowel pins

Remove the H.P.P. valve system (page 8-4).

Piston Removal

CAUTION

- Do not let the clip fall into the crankcase.
- Always support the piston when pressing out the pin.

Remove the following:

- Piston pin clip
- Piston pin
- Piston

NOTE

- Under racing condition, the piston and piston ring should be replaced according to the maintenance schedule. See page 3-4.

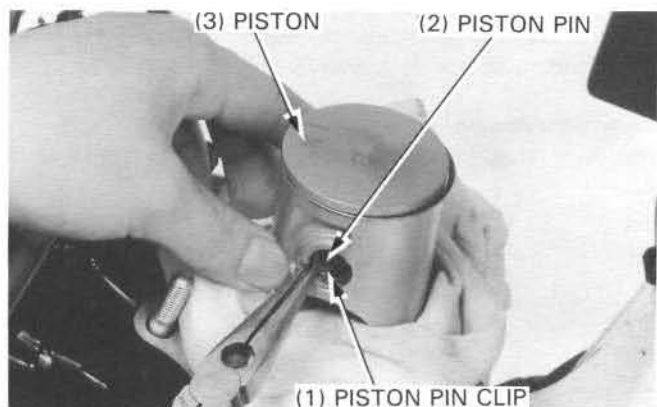
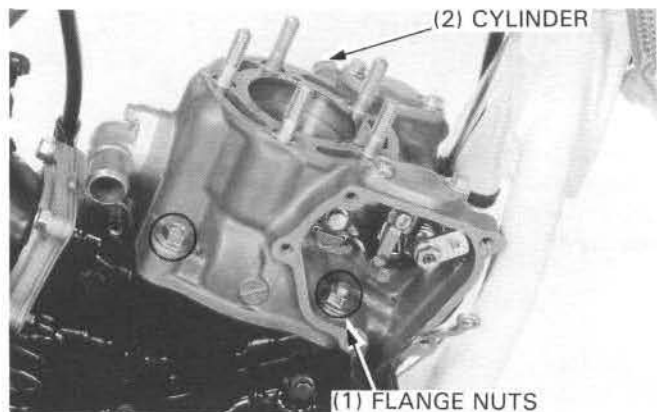

Spread the piston ring and remove by rifting it up at a point just opposite the gap.

CAUTION

- Do not damage the piston by spreading the ends far.

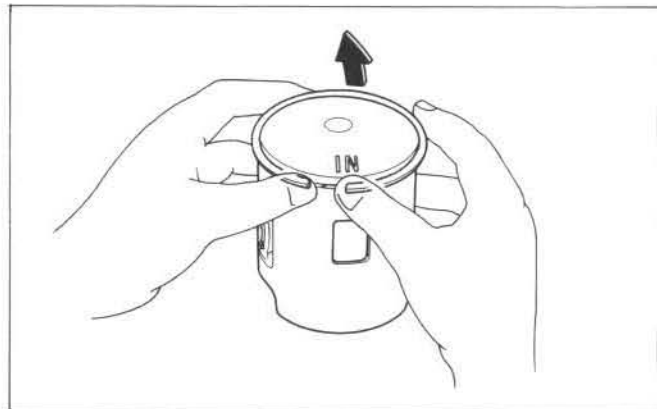

Cylinder Inspection

Remove the carbon deposits from the exhaust port area.

CAUTION

- Do not damage the cylinder bore.

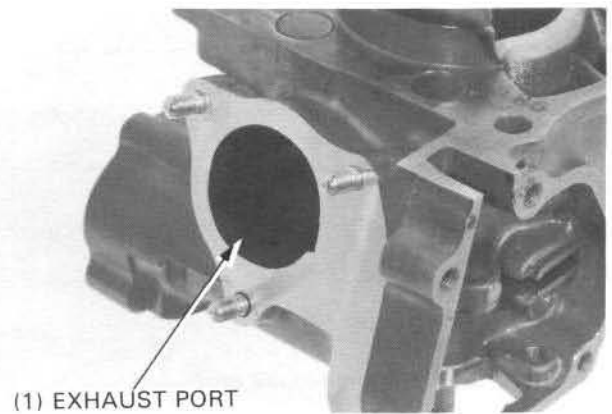

Inspect the top of the cylinder for warpage. Use a straight edge and feeler gauge to check the head gasket surface on the cylinder for warpage. If warpage is beyond the service limit, correct or replace as necessary.

Service Limit: 0.05 mm (0.002 in)

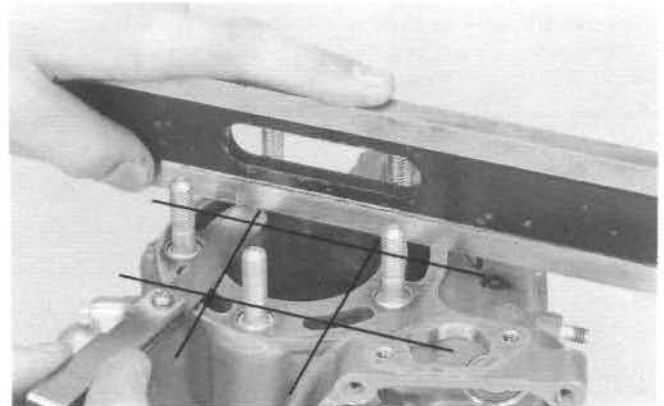

Check that the cylinder studs are tight. If any are loose, remove them, clean their threads with contact cleaner, then reinstall them using Honda Anaerobic Thread Lock or equivalent. Tighten the studs to the specified torque.

Torque: 12 N·m (1.2 kg-m, 9 ft-lb)

If necessary, remove the bolts and water hose joint from the cylinder. Discard the O-ring and install a new one. Install the water hose joint in the reverse order of removal.

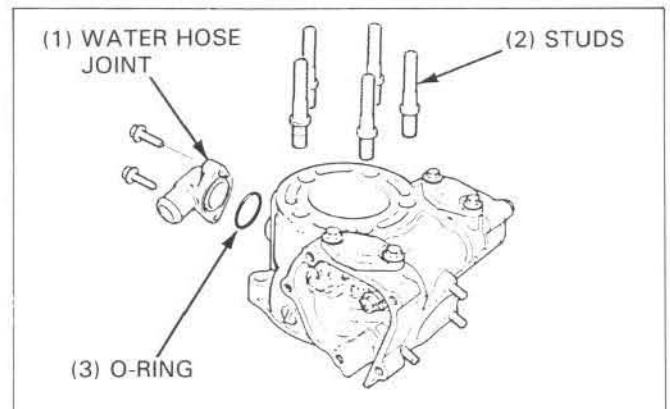

Measure the bore diameter at four positions, top, middle (A), middle (B) and the bottom. With the exception of the bottom, measure both "X" and "Y" axis at each position. Measure only the "X" axis of the bottom position.

- Top: 5 mm (0.2 in)
- Middle (A): 20 mm (0.8 in)
- Middle (B): 70 mm (2.8 in)
- Bottom; 90 mm (3.5 in)

Use the largest figure measured to determine the cylinder wear.

Service Limit: 53.88 mm (2.121 in)

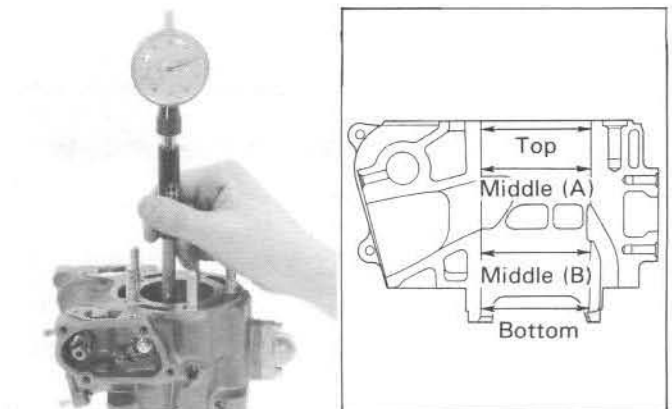

Cylinder Head/Cylinder/Piston

Piston Inspection

Measure the piston O.D. 10 mm (0.39 in) from the bottom of the skirt and at a right angle to the piston pin hole.

Service Limit: 53.88 mm (2.121 in)

If the O.D. is under the service limit, replace the piston with a new one.

Calculate the piston-to-cylinder groove.

Service Limit: 0.07 mm (0.003 in)

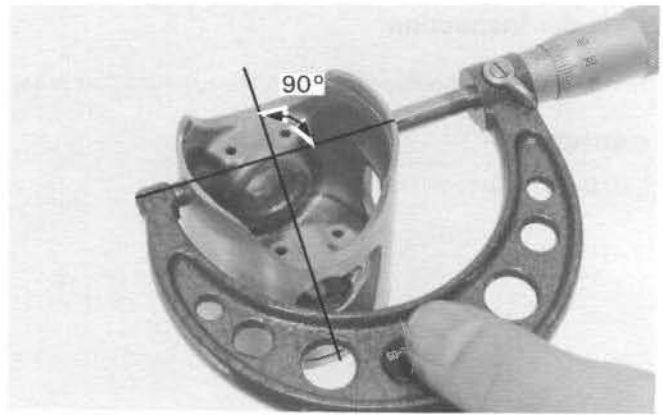

Remove the carbon deposits from the piston ring groove. Measure the piston ring-to-groove clearance.

Service Limit: 0.09 mm (0.004 in)

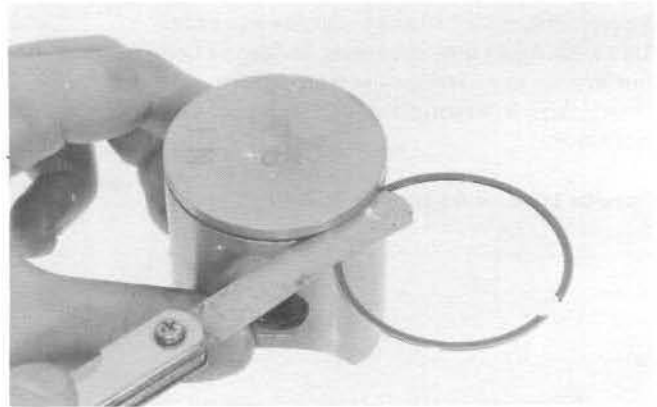

Measure the piston pin bore I.D.

Service Limit: 15.022 mm (0.5914 in)

Check the piston pin for wear and excessive discoloration.

Measure the piston pin O.D.

Service Limit: 14.980 mm (0.5898 in)

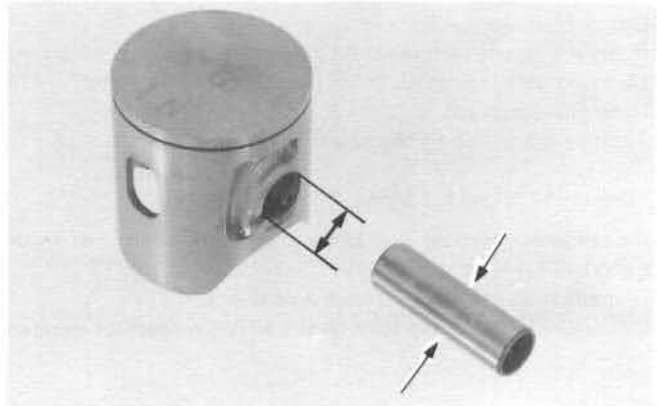

Insert the piston ring into the cylinder.

Use the piston to push the ring squarely into the cylinder.

Measure the piston ring end gap with the feeler gauge.

Service Limit: 0.65 mm (0.026 in)

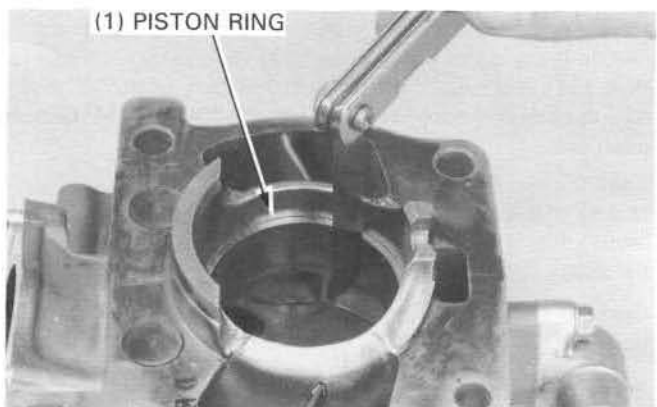

Cylinder/Piston Selection

The cylinders and pistons are select fitted.

Use new cylinders and pistons with the same I.D. and O.D. codes when replacing the cylinder and/or piston.

		Cylinder I.D. Code	
		A	B
Piston O.D. Code	A	○	X
	B	X	○

○: Can be use
X: Cannot be use

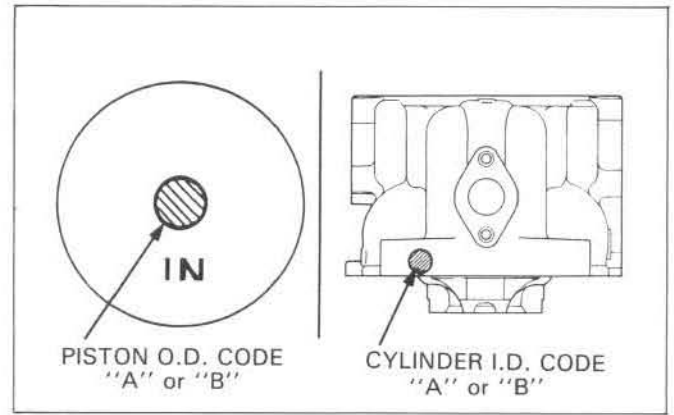

Connecting Rod Inspection

Install the needle bearing and piston pin in the connecting rod small end and check the excessive play.

If it feels loose, measure the connecting rod small end I.D.

Service Limit: 19.022 mm (0.7489 in)

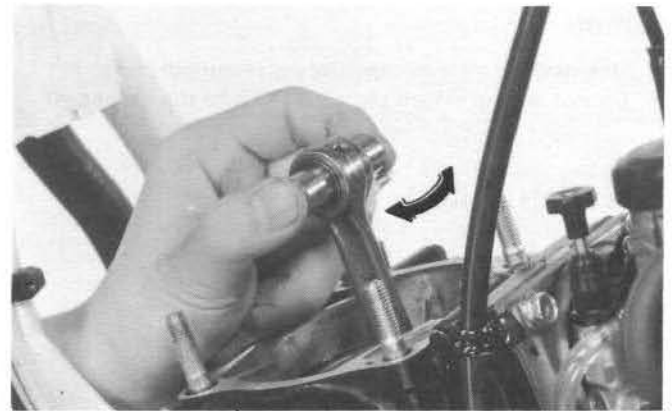

Piston Installation

Clean the piston ring groove.

Lubricate the piston ring and piston ring groove with clean 2-stroke oil.

Install the piston ring on the piston with the mark facing up.

Locate the piston end gap on the pin in the ring groove.

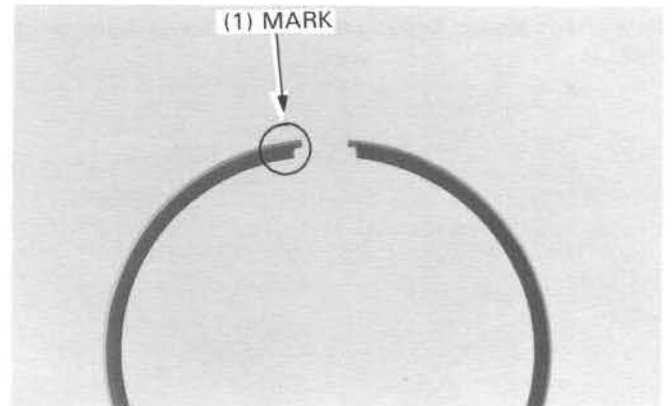

Clean off any gasket material from the cylinder surface.

CAUTION

- Be careful not to remove any material from the gasket surface.



Cylinder Head/Cylinder/Piston

Lubricate the small end bearing and piston pin with clean 2-stroke engine oil.

Install the connecting rod small end bearing, piston and piston ring.

Install the new piston pin clips.

NOTE

- Install the piston with the "IN" mark facing the intake side. If the "IN" mark is obliterated, install the piston with the hole facing the intake side.

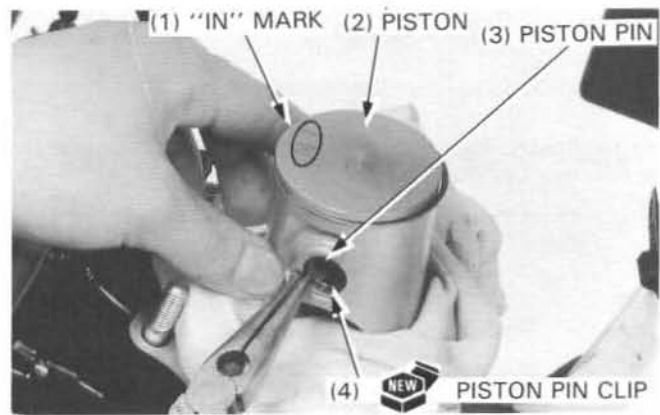

CAUTION

- Use new piston pin clips. Never reuse old clips.
- Do not let the piston pin clips fall into the crankcase.

Cylinder Installation

Align the ring end gap with the piston ring pin.



Place the cylinder base gasket and dowel pins on the crankcase.

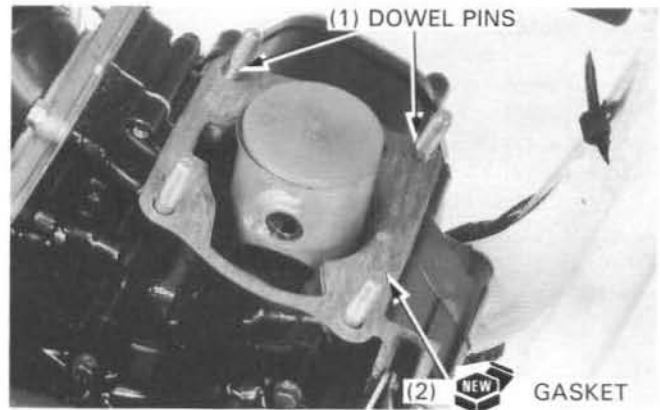

Lubricate the piston with clean 2-stroke engine oil and slip the cylinder over the piston while compressing the piston ring.

CAUTION

- Do not rotate the cylinder, since this may cause the piston ring to snag a cylinder port and break.

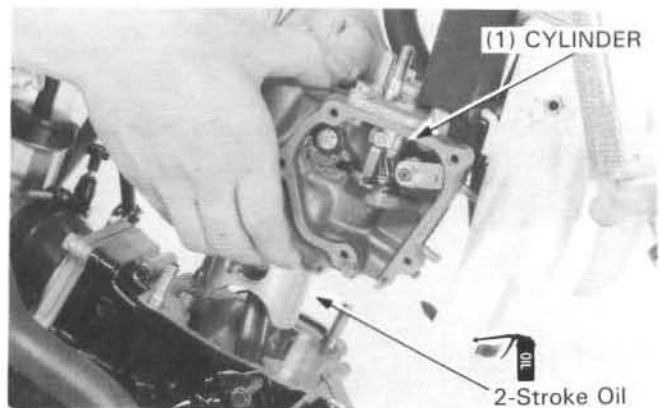

Install the four flange nuts and tighten to the specified torque.

Torque: 27 N·m (2.7 kg-m, 20 ft-lb)

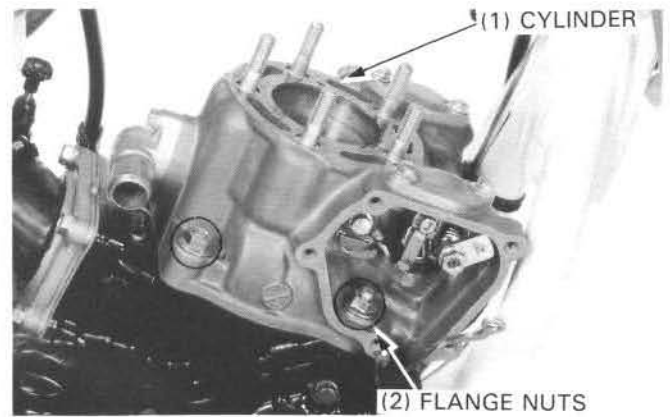

Install the H.P.P. valve rod by pushing it down and onto the pin.
Attach the rod using the setting collar and B-clip.

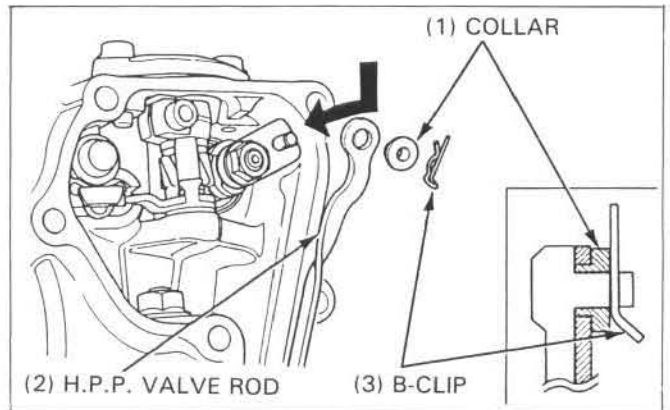

Position the gasket on the link cover.
Install the grommet and link cover.
Install the cover using the five mounting bolts and one screw.
Tighten the bolts and screw to the specified torque.

Torque: Bolts: 12 N·m (1.2 kg-m, 9 ft-lb)
Screw: 2.5 N·m (0.25 kg-m, 1.8 ft-lb)

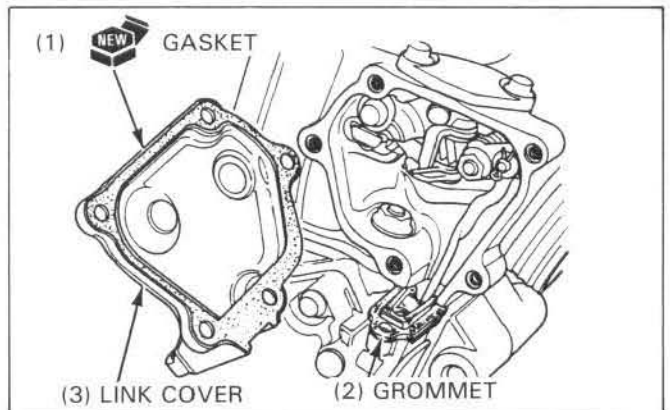

Connect the radiator lower joint hose and tighten the hose clamp screws.
Install the right radiator bolts and tighten the all mounting bolts.

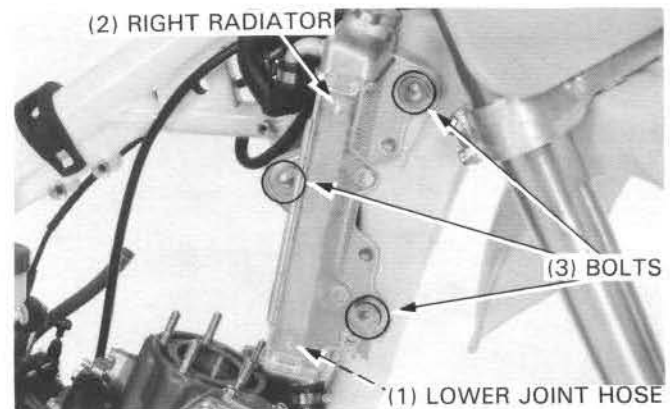

Cylinder Head/Cylinder/Piston

Install the water hose and tighten the hose clamp screw securely.

Install the following:

- Expansion chamber (page 2-4)
- Cylinder head (page 7-3)
- Fuel tank and seat (page 2-3)

Pour the recommended coolant mixture into the radiator up to the correct level (page 5-3).

Check for the following:

- Compression leaks
- Abnormal engine noise
- Secondary air leak
- Coolant leaks

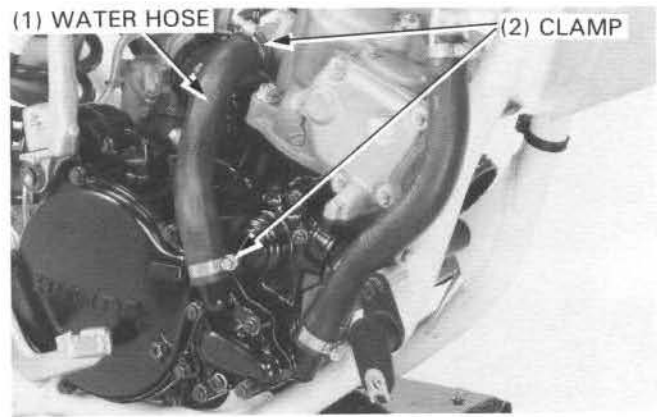

MEMO

RIDE RED

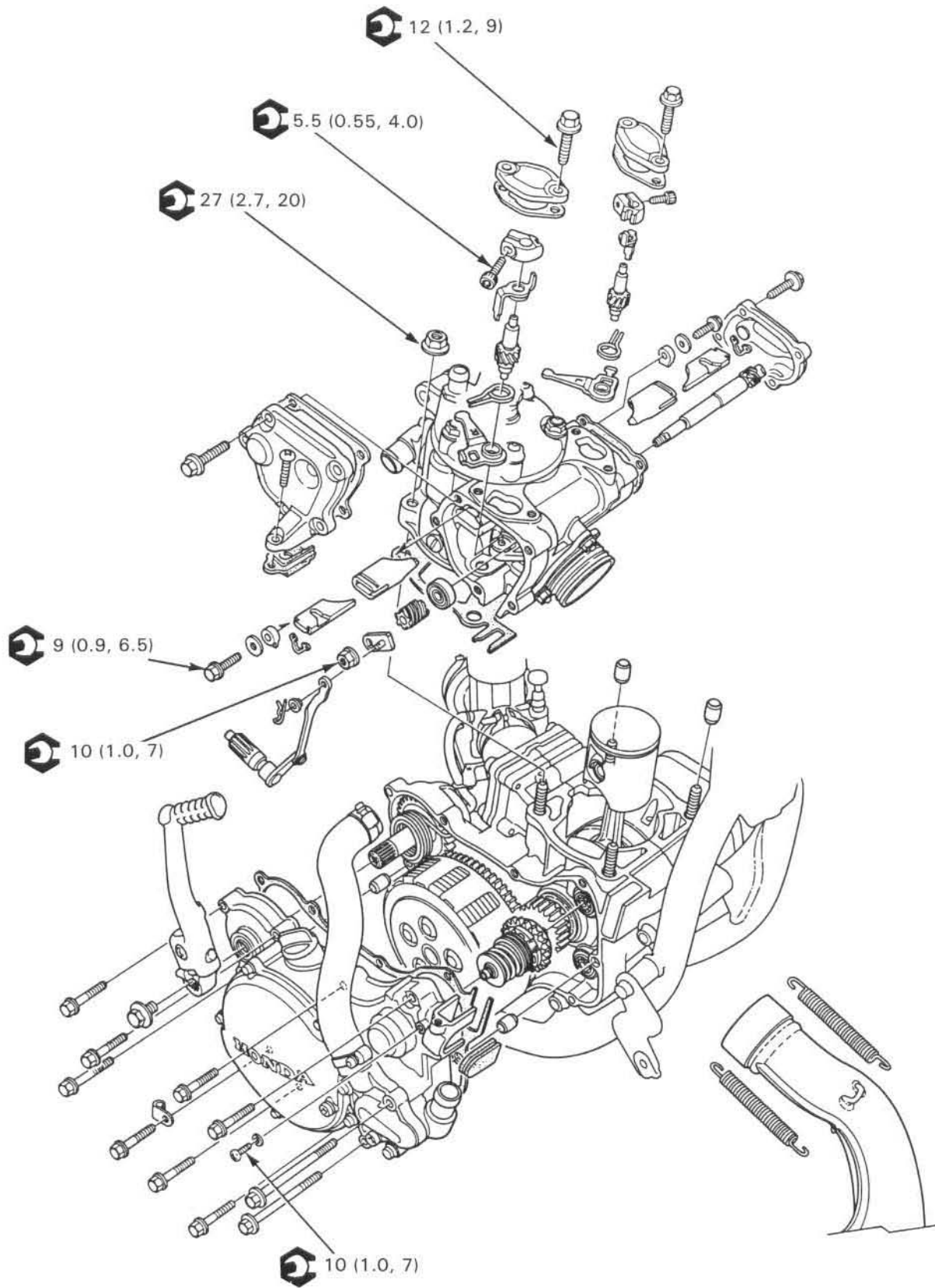

8. H.P.P. (Honda Power Port)

Service Information	8-1	Exhaust Valve	8-2
Troubleshooting	8-1	Exhaust Valve Drive Shaft	8-7
Exhaust Deposit Draining	8-2	Governor/Valve Linkage	8-9

Service Information

General

- This section covers the maintenance of the H.P.P. (Honda Power Port).
- Decarbonize the valve every 7.5 hours of running (or every three races).
- Adjust the valve system only when
 - The valve doesn't close properly.
 - The linkage has been removed.
 - Related parts (governor, cam, water pump shaft) have been removed or replaced.

Torque Values

Cylinder head nut	27 N•m (2.7 kg-m, 20 ft-lb)
Cylinder mounting bolt	27 N•m (2.7 kg-m, 20 ft-lb)
Cylinder stud	12 N•m (1.2 kg-m, 9 ft-lb) Apply a locking agent
Engine hanger bracket bolt	27 N•m (2.7 kg-m, 20 ft-lb)
H.P.P. drain bolt	10 N•m (1.0 kg-m, 7 ft-lb)
H.P.P. valve cover bolt	12 N•m (1.2 kg-m, 9 ft-lb)
H.P.P. valve cover screw	2.5 N•m (0.25 kg-m, 1.8 ft-lb)
Cylinder upper cover bolt	12 N•m (1.2 kg-m, 9 ft-lb)
H.P.P. valve guide bolt	9 N•m (0.9 kg-m, 6.5 ft-lb)
H.P.P. pinion holder socket bolt	5.5 N•m (0.55 kg-m, 4.0 ft-lb)

Tools

Special

Bearing remover, 7 mm	07931 – KA30000
Bearing driver, 7 mm	07946 – KA30100

Common

Driver	07749 – 0010000
Attachment, 24 x 26 mm	07746 – 0010700

Troubleshooting

Poor Performance At Low Speed

- Exhaust valve does not close fully
 - Improper adjustment
 - Faulty governor
 - Broken pinion lever spring
 - Bent valve rod
 - Damaged drive shaft bearing
- Excessive carbon build-up in exhaust valves and valve guides
- Damaged exhaust valve

Poor Performance At High Speed

- Exhaust valve does not open fully
 - Improper installation
 - Faulty governor
 - Broken pinion lever spring
 - Damaged drive shaft bearing
- Excessive carbon build-up in exhaust valves and valve guides
- Damaged exhaust valve

Exhaust Deposit Draining

Remove the drain bolt and drain the exhaust deposits from the right crankcase cover.

NOTE

- Under racing conditions, drain the exhaust deposits after every 22.5 hours of running.

Install and tighten the drain bolt to the specified torque.

Torque: 10 N·m (1.0 kg·m, 7 ft·lb)



Exhaust Valve

Inspection

Remove the expansion chamber (page 2-4).

Remove the right and left exhaust valve covers from the cylinder.

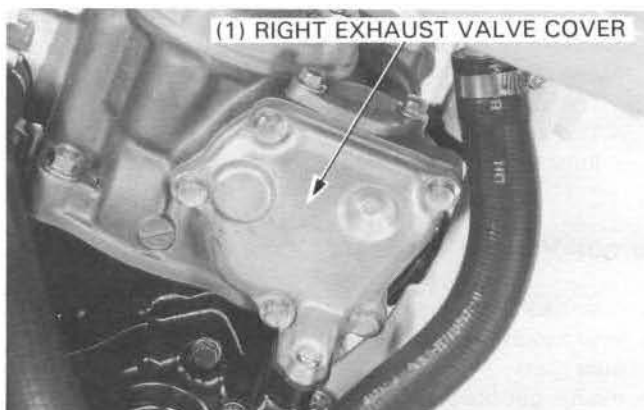

Check that the valve is fully closed.

In this position the E-clip of the valve should be in contact with the valve guide.

NOTE

- Before each race, be sure that the valve is fully closed.
- If there is any clearance between the E-clip and valve guide, disassemble and decarbonize the valves. See Decarbonizing, page 8-5.

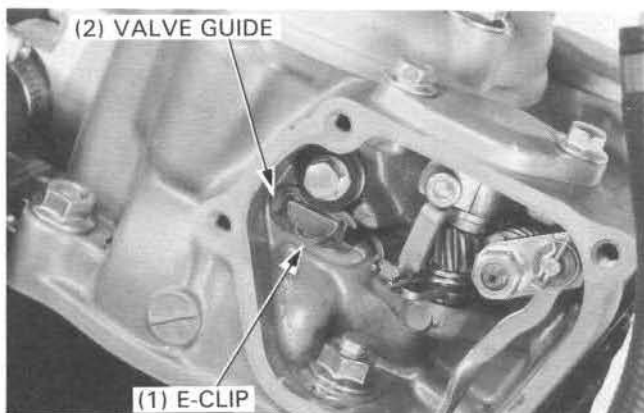

Adjustment

Loosen the both side pinion shaft holder socket bolts and turn the pinion lever to contact the E-clip with the valve guide.

Check that the E-clip is in contact with the valve guide.

NOTE

- If there is any clearance between the E-clip and valve guide, disassemble and decarbonize the valve (page 8-5).
- Decarbonize the valves, before adjustment.

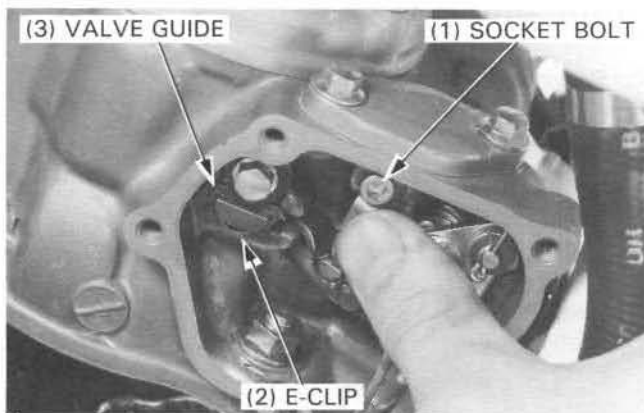

Temporarily tighten the right pinion shaft holder socket bolt while pushing on the valve guide pinion lever. This ensures that all of the slack is removed in the exhaust valve system.

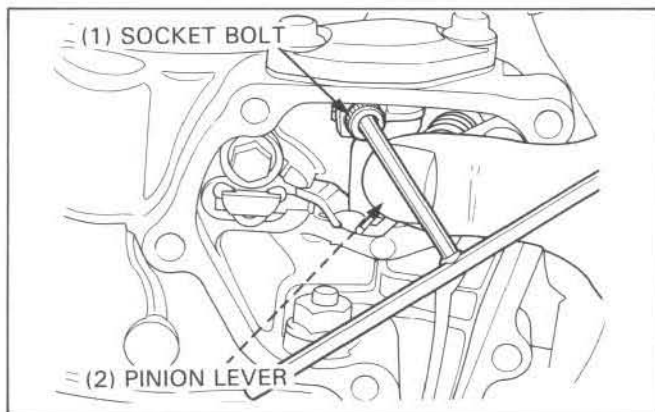

Tighten the left side pinion shaft holder socket bolt while pushing on the valve guide pinion lever.

Torque: 5.5 N·m (0.55 kg-m, 4.0 ft-lb)

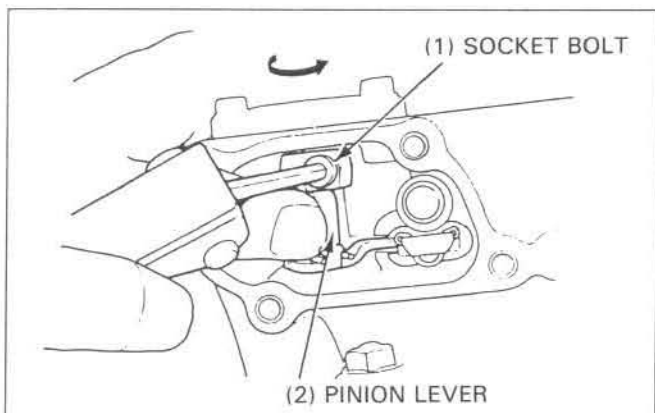

Loosen right socket bolt and torque the socket bolt using same procedure as for the left side.

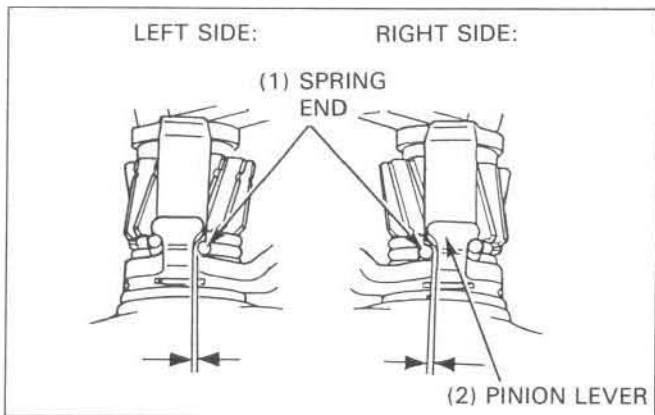

Check the clearance between the end of the pinion lever return spring and pinion lever as shown.

Clearance: 0.5 – 2.0 mm (0.02 – 0.08 in)

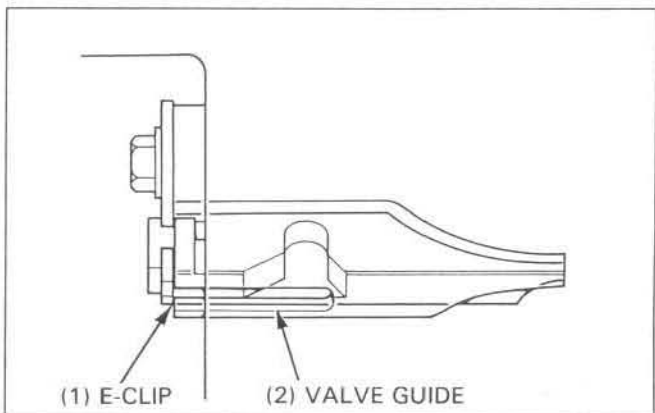

H.P.P. (Honda Power Port)

Install the H.P.P. valve rod by pushing down on the rod. Attach the rod to the drive shaft lever pin using the setting collar and B-clip.

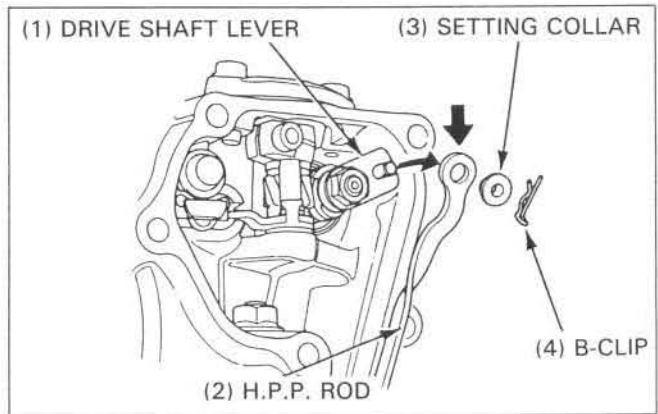

Position the gasket on the exhaust cover as shown. Install the grommet and exhaust cover. Install the cover using the mounting bolts and one screw. Tighten the bolts and screw to the specified torque.

Torque: Bolts: 12 N·m (1.2 kg·m, 9 ft·lb)
Screw: 2.5 N·m (0.25 kg·m, 1.8 ft·lb)

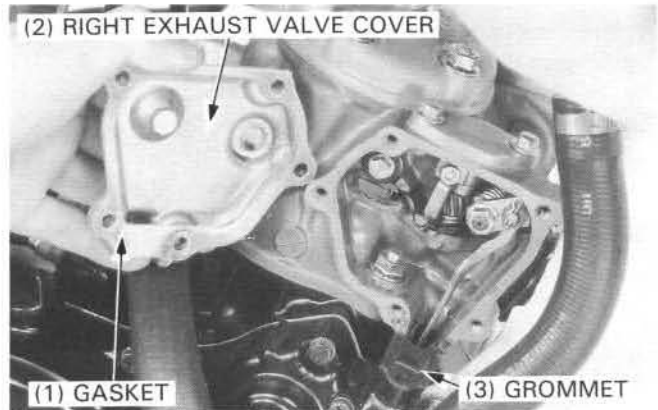

Disassembly

Remove the following:

- Right and left exhaust valve cover
- Gaskets, grommet
- Pinion holder socket bolt
- Cylinder upper cover
- Pinion holder

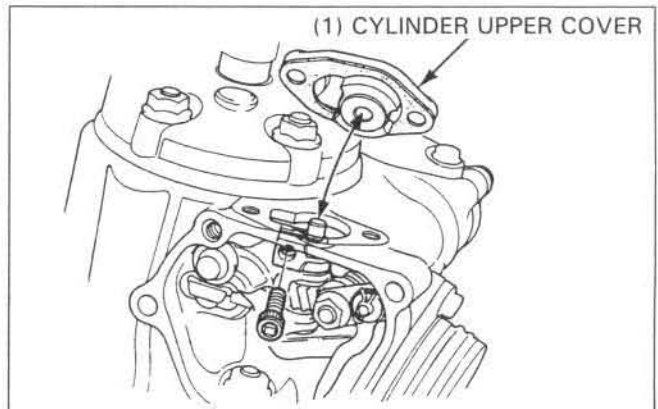

Pull the exhaust valve out, and remove the valve lever from the exhaust valve. Remove the pinion shaft assembly from the cylinder.

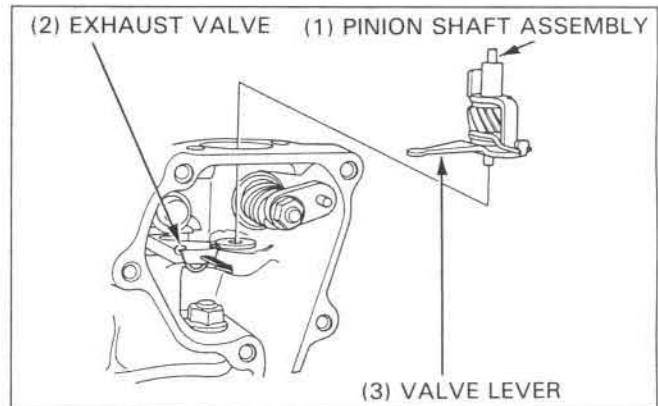

Remove the valve guide locking plate bolt, washer and locking plate.

Remove the valve guide from the cylinder.

Remove the opposite exhaust valve using the same procedure as used on the right.

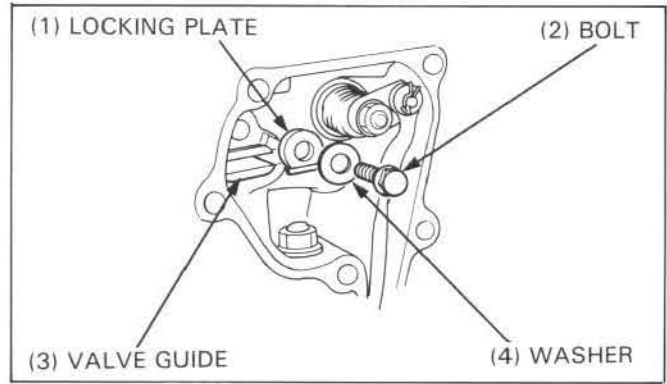

Disassembly the pinion shaft assembly.

Decarbonizing

Remove the carbon deposits from the exhaust valves and valve guides.

NOTE

- Decarbonize the exhaust valves and exhaust valve guides each race.

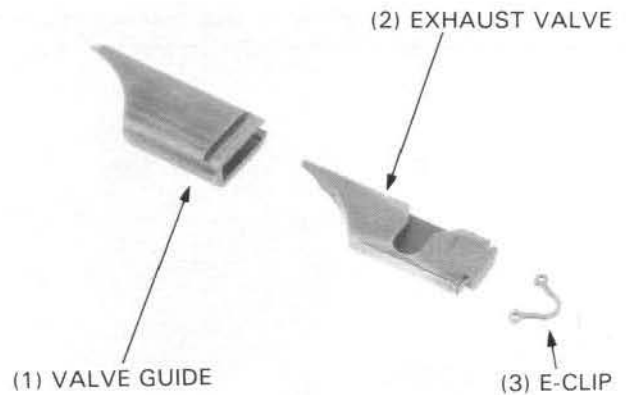

Inspection

Inspect the pinion gear, valve lever, pinion lever spring and pinion shaft for wear or damage.

Check the following item:

- Sliding surface of valve
- Sliding surface of valve guide
- Groove of attaching E-clip
- Pinion shaft

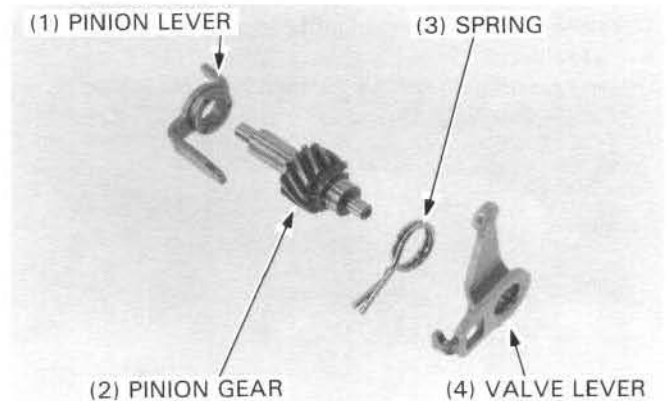

Assembly

Apply recommended 2-stroke engine oil to the valve guide and valve.

Install the valve guides into the cylinder.

Install the lock plate aligning its tab with the groove of the valve guide.

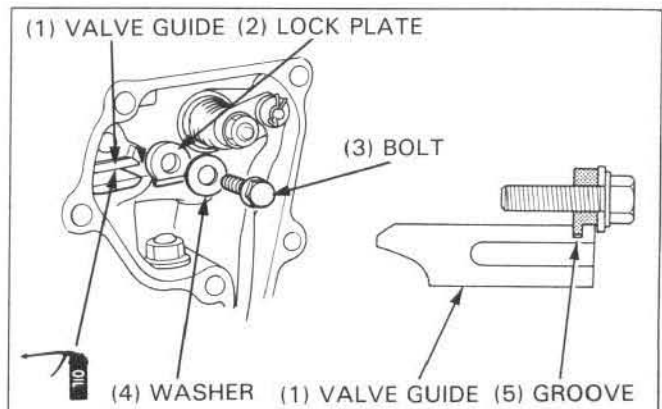

H.P.P. (Honda Power Port)

Be sure the tab is seated securely. Refer to illustration.

Install the bolt with its washer and tighten the bolts to the specified torque.

Torque: 9 N·m (0.9 kg-m, 6.5 ft-lb)

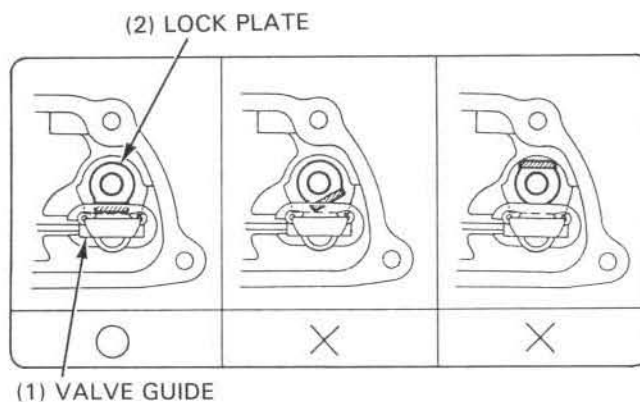

Assemble the E-clips onto the exhaust valves and insert the valves into the guides with the valve groove facing up.

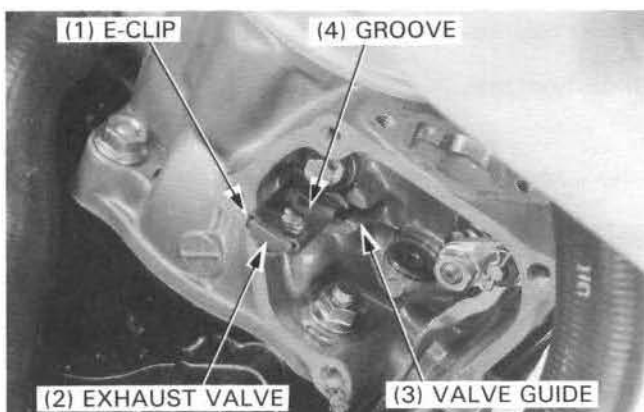

The valve levers have the identification marks for right side: R, and left side: L.

The left pinion gear has an identification groove on its teeth.

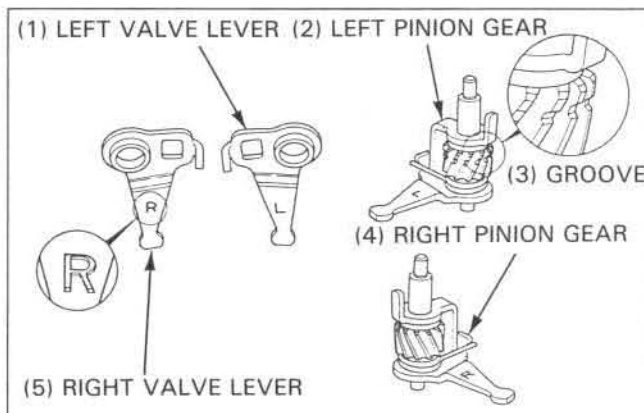

NOTE

- Install the valve lever with the identification mark facing up.

Assemble the valve lever, pinion lever spring, pinion gear and valve lever as shown.

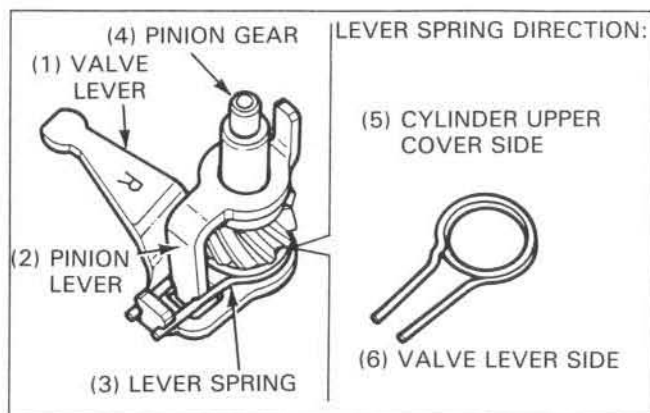

Position the exhaust valve fully open.

Apply molybdenum disulfide oil to the ends of the pinion shaft.

Install the pinion shaft assembly aligning the valve lever with the exhaust valve groove.

Install the pinion holder aligning the groove with the pinion lever.

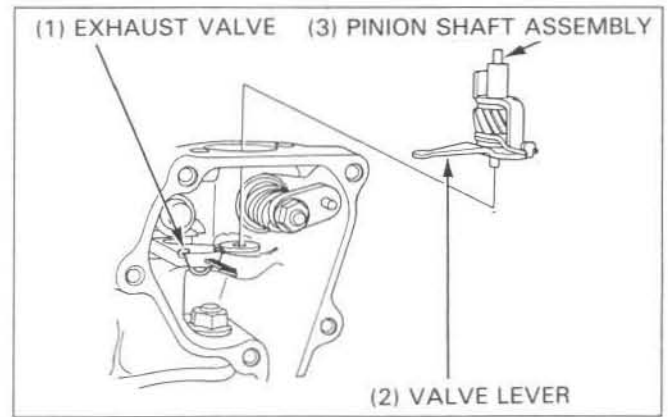

Install the cylinder upper cover gaskets and covers then tighten the bolts.

Adjust the exhaust valve (page 8-2).

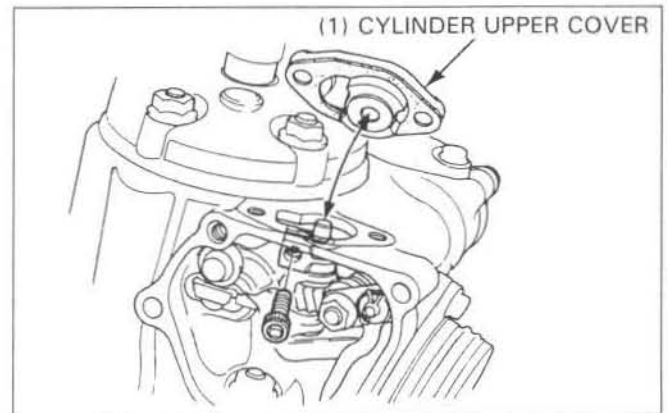

Exhaust Valve Drive Shaft

Disassembly

Remove the B-clip and setting collar, then remove the valve rod from the drive shaft lever.

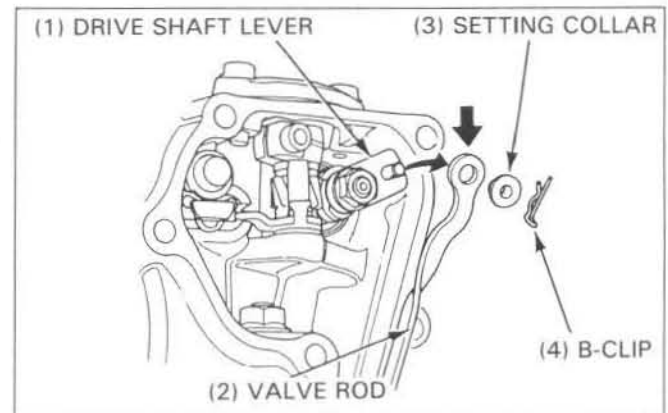

Check the smooth operation of the drive shaft.
If the operation is not smooth, remove the drive shaft as follow.

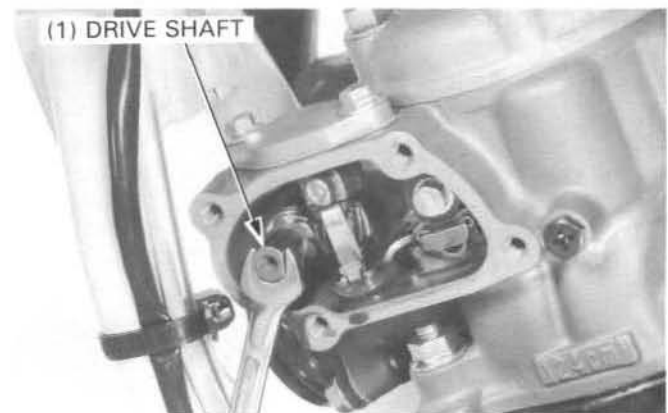

H.P.P. (Honda Power Port)

Remove the drive shaft nut.

Remove the drive shaft lever and pinion gear, then remove the drive shaft from the left side.

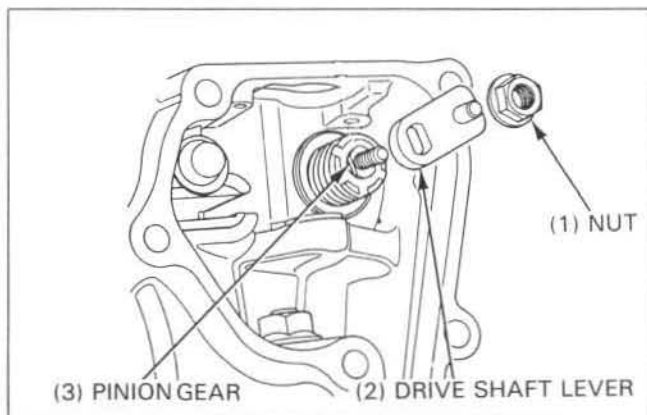

Inspection

Check the drive shaft wear or damage.
Check the each gear wear or damage.

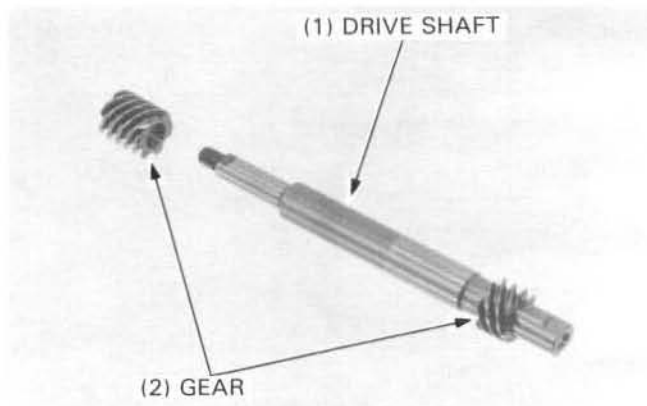

Turn the each bearing inner race with your finger.

The bearing should turn smoothly and quietly.
Also check that the bearing outer race has not been spinning in its seat.

Discard the bearing if the race does not turn smoothly and quietly, or if they have been spinning in its seat.



Drive Shaft Bearing Replacement

Remove the bearing using the special tools.

 S-TOOL

Bearing remover, 7 mm

07931-KA30000



Drive in the new bearing into its seat in the cylinder head.



Bearing driver, 7 mm

07946-KA30100

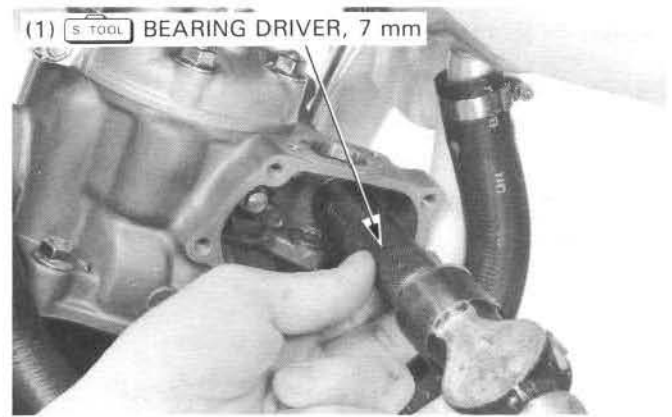

Installation

Apply molybdenum disulfide oil to the drive shaft surface.

Install the exhaust valve drive shaft from the left side.

Install the drive shaft gear.

Install the drive shaft lever aligning the cut-out of the shaft lever and tighten the nut to the specified torque.

Torque: 12 N·m (1.2 kg·m, 9 ft·lb)

Install the exhaust valve link and cover (page 7-11)

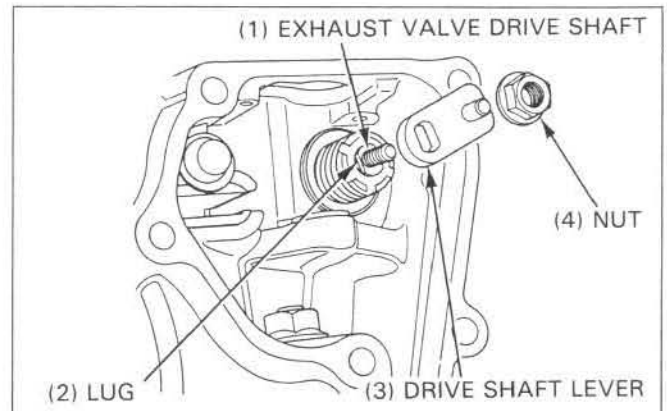

Governor/Valve Linkage

Removal

Remove the following:

- Exhaust valve cover and link (page 7-6)
- Right crankcase cover (page 9-2)

Remove the pinion gear by removing the retaining screw, washer and grommet.

Remove the governor assembly by pulling it off the shaft.

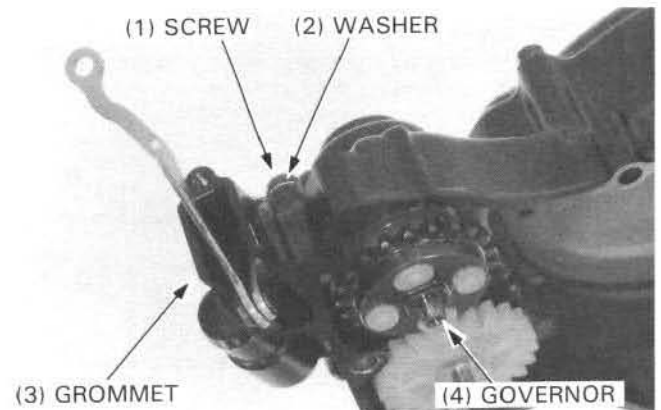

Inspection

Inspect the pinion gear teeth for excessive wear or damage.

Inspect the governor gear teeth for excessive wear or damage.

CAUTION

- Do not disassemble the governor.

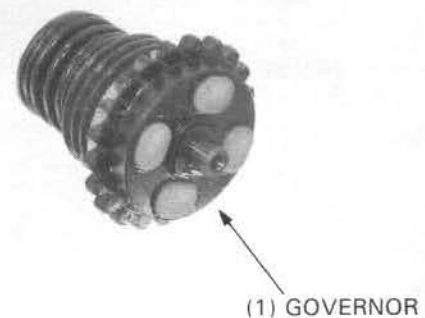

Governor Shaft Bearing Replacement

Right Crankcase Side:

Remove the bearing using the special tool.

 S. TOOL

Bearing remover, 7 mm 07931-KA30000



Drive in the new bearing into the right crankcase.

 S. TOOL

Bearing driver, 7 mm 07946-KA30100



Right Crankcase Cover Side:

Remove the bearing by thermally expanding the case:
Slowly and uniformly heat the case with a heat gun (industrial dryer).

⚠ WARNING

- To avoid burns, wear insulated gloves when handling the heated parts.

CAUTION

- Using a torch to heat the case may cause warping.

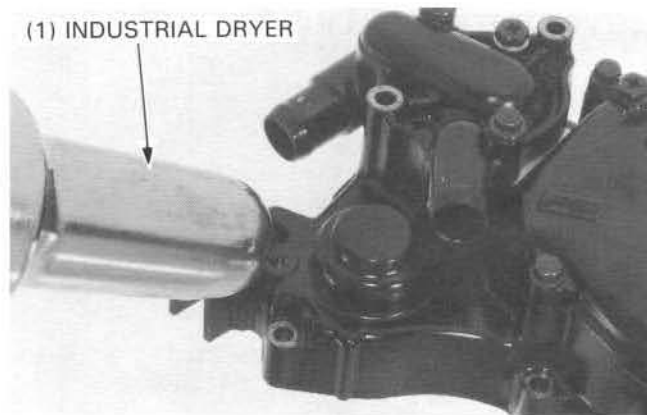

Drive in the new bearing into the right crankcase.

 S. TOOL

Driver 07749-0010000
Attachment, 24 x 26 mm 07746-0010700

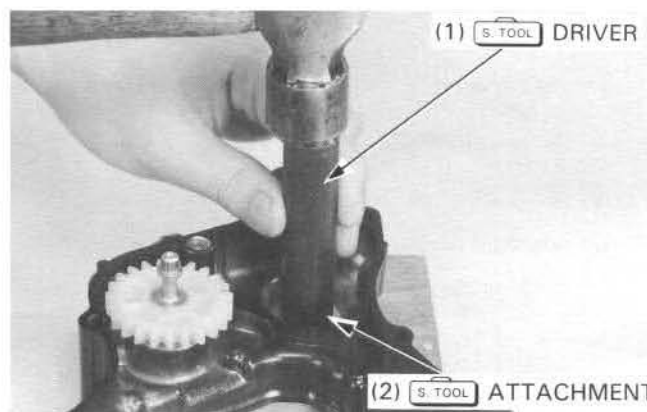

Apply recommended transmission oil to the pinion gear.

Install the pinion gear and retaining screw with its washer.

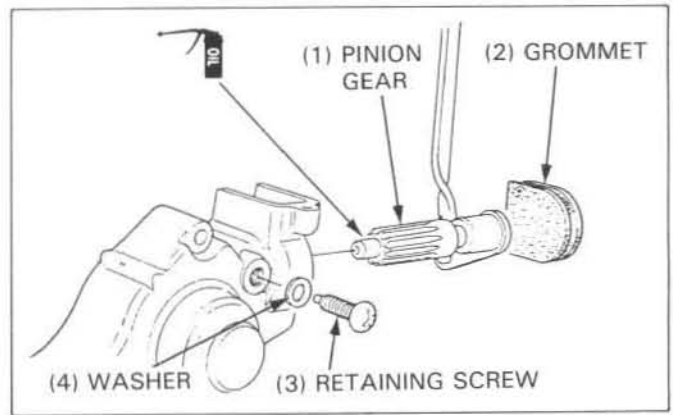

Align the center of valve rod joint with the mating surface of the right crankcase cover.

Install the governor.

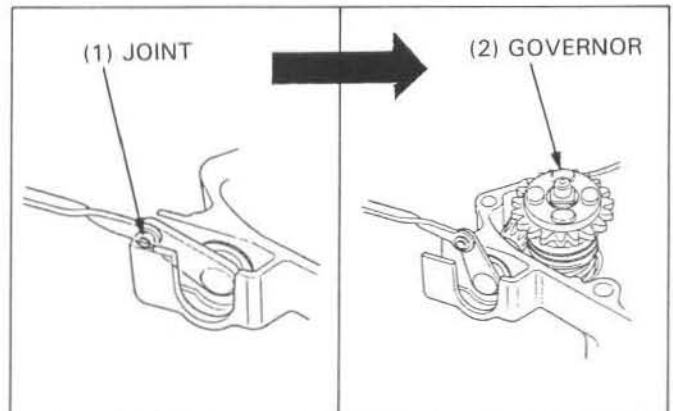

Make sure that the center of valve rod joint lines up with the edge of the cutout.

Install the washer and setting screw.

Tighten the screw to the specified torque.

Torque: 9 N·m (0.9 kg·m, 6.5 ft·lb)

Install the grommet with its tab facing outside as shown.

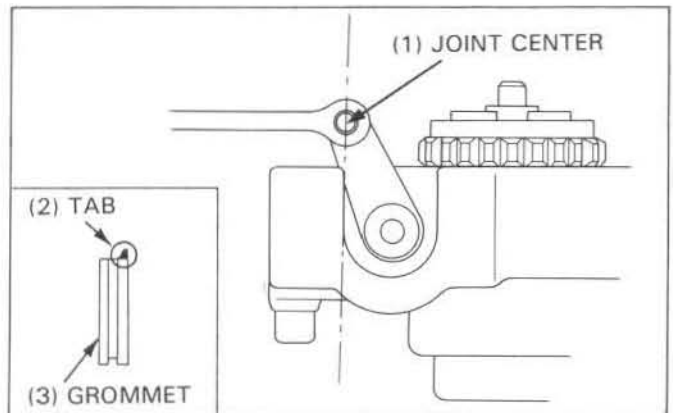

Install the following:

- Right crankcase cover (page 9-2)
- Exhaust valve rod and cover (page 7-11)

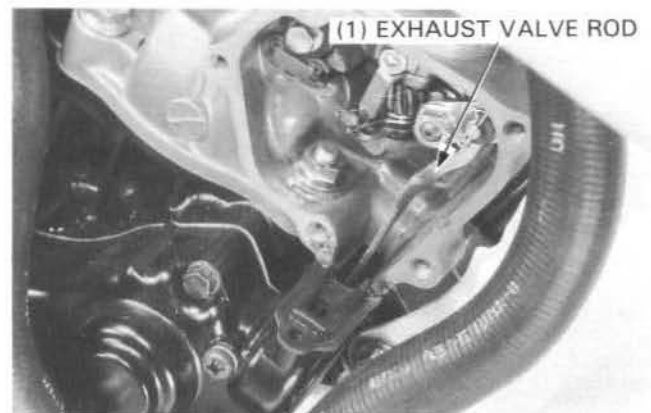

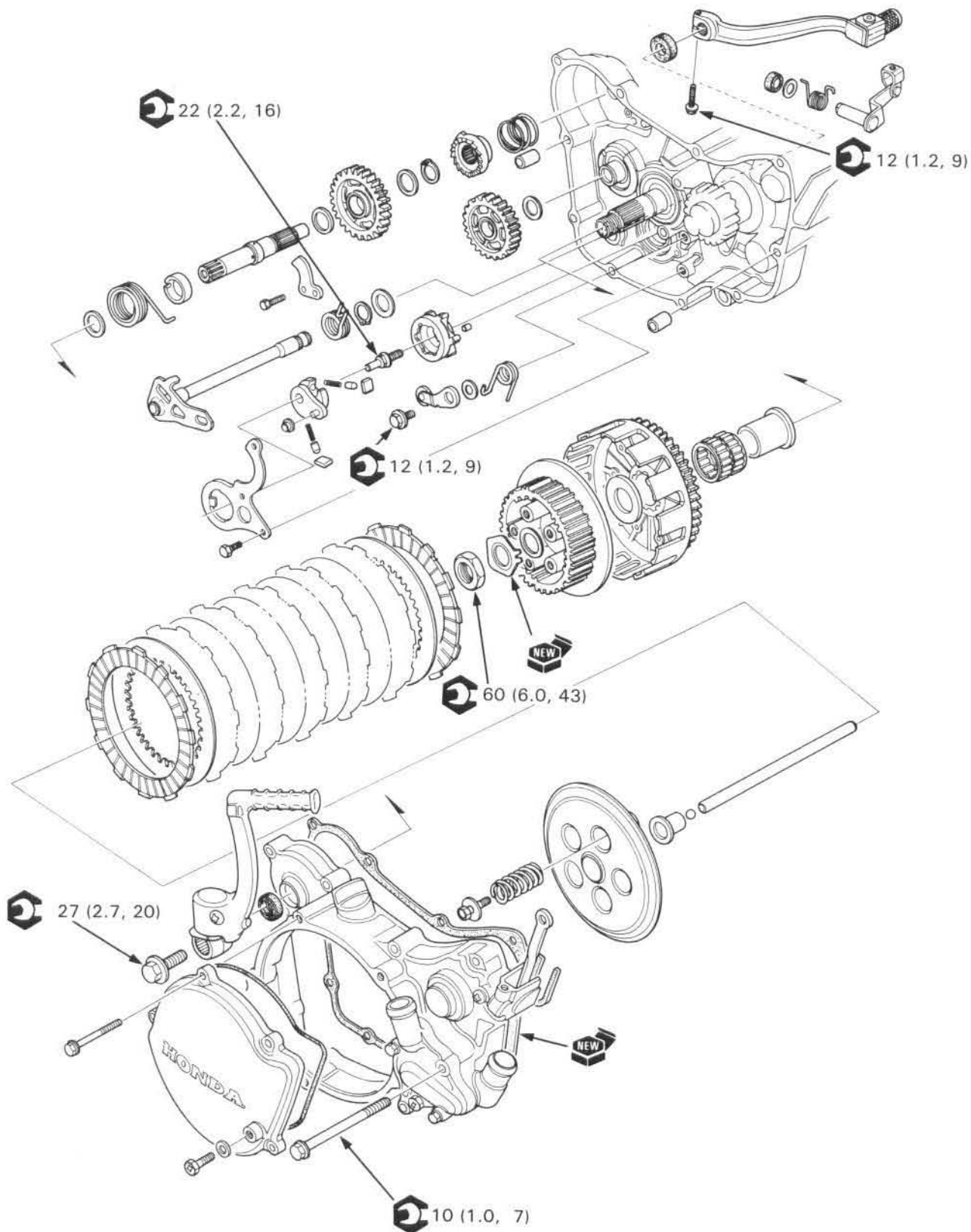

9. Clutch/Kickstarter/Gearshift Linkage

Service Information	9-1	Clutch	9-3
Troubleshooting	9-1	Kickstarter	9-9
Right Crankcase Cover	9-2	Gearshift Linkage	9-11

Service Information

General

- Clutch maintenance can be done with the engine/transmission in the frame.
- Transmission oil viscosity and level have an effect on clutch disengagement. When the clutch does not disengage or the vehicle creeps with clutch disengaged, inspect the transmission oil level before servicing the clutch system.

Specifications

Unit: mm (in)

Item	Standard	Service Limit
Clutch lever free play	10–20 (3/8–3/4)	—
Clutch spring free length	39.4 (1.55)	37.5 (1.48)
Clutch disc thickness	2.92–3.08 (0.114–0.121)	2.85 (0.112)
Clutch plate warpage	—	0.15 (0.006)

Torque Values

Right crankcase cover/clutch cover bolt	10 N•m (1.0 kg-m, 7 ft-lb)
Clutch center lock nut	60 N•m (6.0 kg-m, 43 ft-lb)
Clutch spring bolt	10 N•m (1.0 kg-m, 7 ft-lb)
Shift drum center pin	22 N•m (2.2 kg-m, 16 ft-lb)
Shift drum stopper arm bolt	12 N•m (1.2 kg-m, 9 ft-lb)
Kickstarter pedal bolt	27 N•m (2.7 kg-m, 20 ft-lb) Apply a locking agent

Tools

Common

Clutch center holder	07724–0050001
----------------------	---------------

Troubleshooting

Hard To Shift

- Incorrect clutch adjustment
- Loose stopper plate bolt
- Damaged stopper plate and pin
- Damaged gearshift spindle

Transmission Jumps Out Of Gear

- Worn shift drum stopper arm
- Weak or broken shift arm return spring
- Loose stopper plate bolt

Gearshift Pedal Will Not Return

- Weak or broken gearshift spindle return spring
- Bent gearshift spindle

Clutch Slips When Accelerating

- Incorrect clutch adjustment
- Worn clutch discs
- Weak clutch springs
- Transmission oil mixed with molybdenum or graphite additive

Motorcycle Creeps With The Engine Idling

- Incorrect clutch adjustment
- Clutch plates warped
- Faulty clutch lifter
- Incorrect transmission oil

Right Crankcase Cover

Removal

Drain the coolant (page 5-3).
Drain the transmission oil.

Remove the following:

- Expansion chamber (page 2-4)
- Brake pedal (page 13-14)
- Kickstarter pedal
- Right exhaust valve cover and exhaust valve rod (page 7-4)

Disconnect the radiator hoses from the right crankcase cover.

Remove the crankcase cover bolts and right crankcase cover.

Remove the gasket and dowel pins.

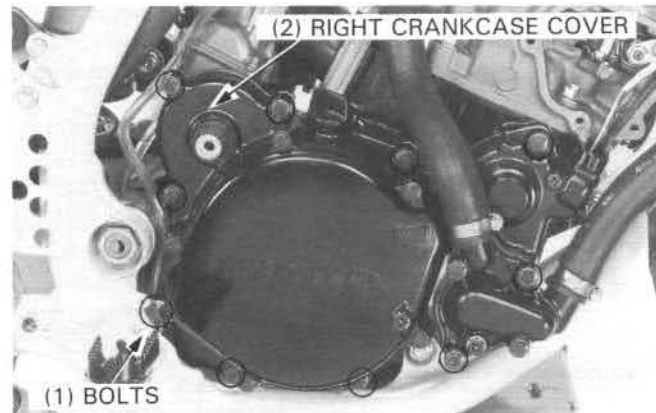
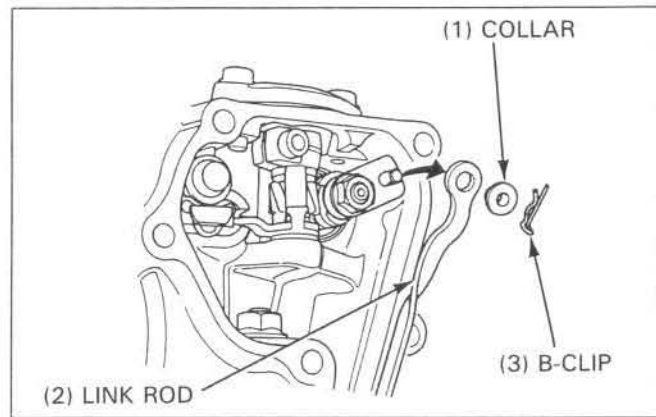

Installation

Place a new gasket on the right crankcase cover and cut the end of the gasket flush with the end as shown.

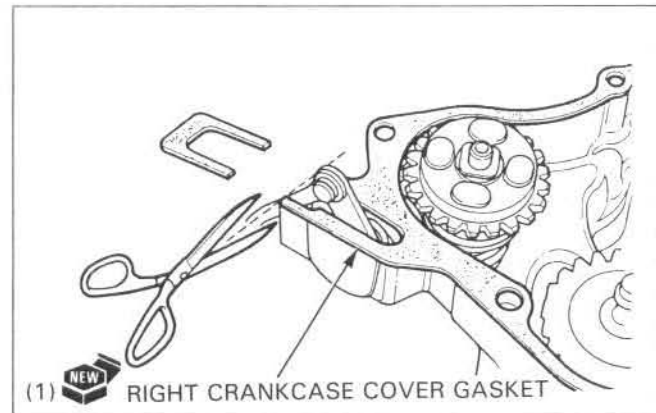

Install the dowel pins and new gasket.

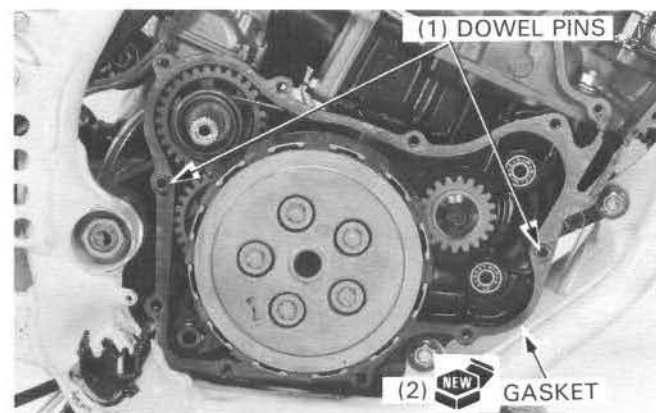

Install the right crankcase cover and tighten the bolts.

NOTE

- Be sure the water pump gear and the primary drive gear mesh properly during the cover installation.
- Clamp the air vent tube bracket using the right crankcase cover bolt.

Torque: 10 N·m (1.0 kg-m, 7 ft-lb)

Connect the radiator hoses to the right crankcase cover.



Install the following:

- Exhaust valve rod and cover (page 7-11)

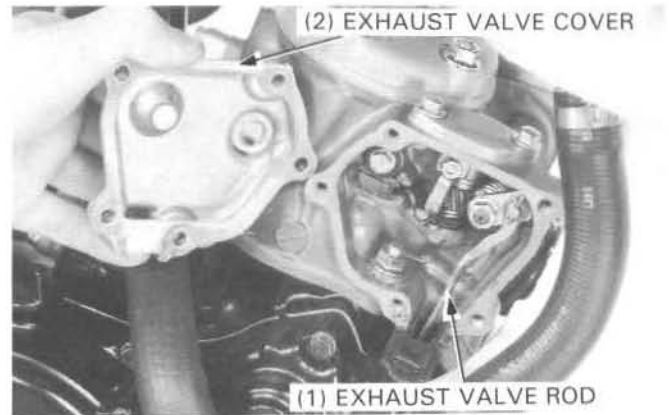

- Expansion chamber (page 2-4)
- Brake pedal (page 13-14)

Install the kickstarter pedal.

Clean the kickstarter pedal bolt thread and apply Honda Anaerobic Thread Lock or equivalent.

Tighten the bolt to the specified torque.

Torque: 27 N·m (2.7 kg-m, 20 ft-lb)

Fill the transmission with recommended oil to the correct level.

Add the radiator coolant mixture into the radiator up to the correct level (page 5-3).

Check and adjust the rear brake height.
Start the engine and check for oil leaks.

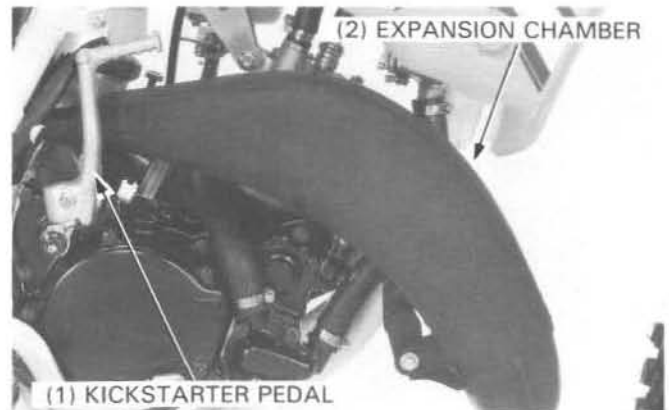

Clutch

Clutch Removal

Remove the brake pedal (page 13-14).

Remove the bolts and clutch cover.

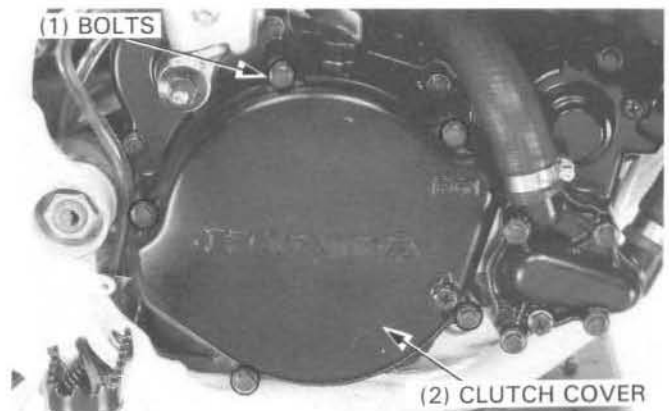

Clutch/Kickstarter/Gearshift Linkage

Gradually remove the five clutch spring bolts in a crisscross pattern and remove the clutch spring.

Remove the clutch pressure plate.

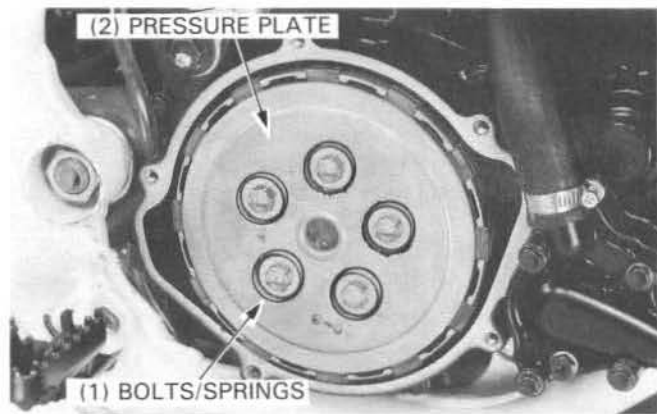

Remove the clutch lifter, steel ball and clutch lifter rod.

NOTE

- To avoid losing the steel ball, be careful when you remove the clutch lifter.

Remove the seven clutch friction discs and six clutch plates.

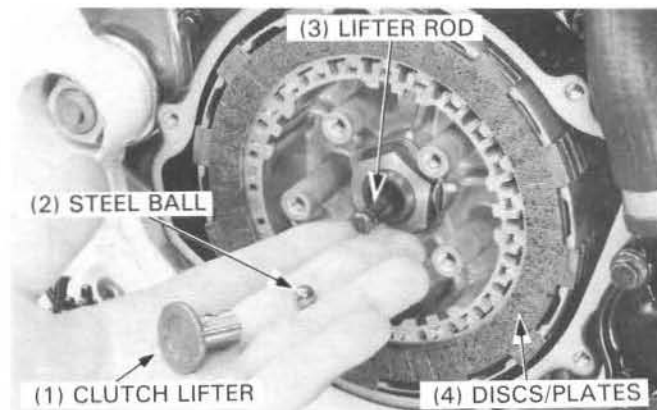

Bend the tabs of the lock washer away from the lock nut.

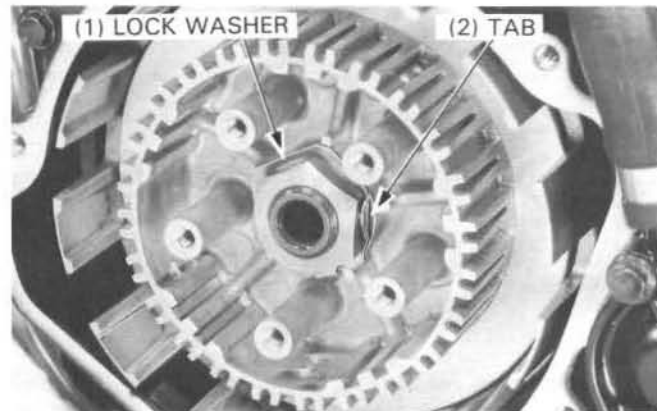

Hold the clutch center with the clutch center holder.
Remove the lock nut, lock washer and thrust washer.

S. TOOL

Clutch center holder 07724-0050001

Remove the tool and clutch center.

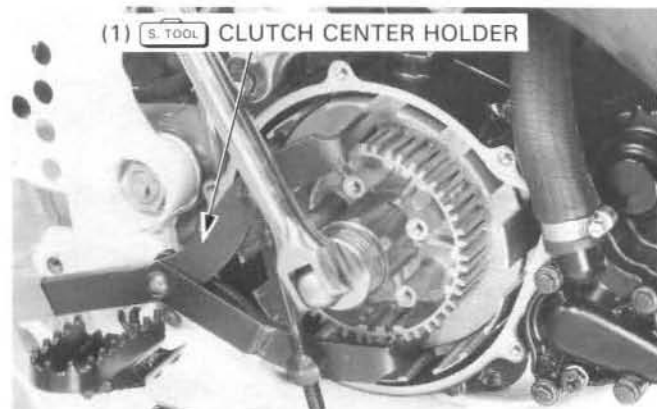

Remove following:

- Thrust washer
- Clutch outer
- Needle bearing
- Clutch outer guide



Clutch Lifter Lever Removal

Remove the alternator cover (page 14-6).

Disconnect the clutch cable from the clutch lifter lever by loosening the clutch cable adjuster.

Remove the flywheel and stator (page 14-6).

Remove the return spring and clutch lifter lever from the left crankcase.

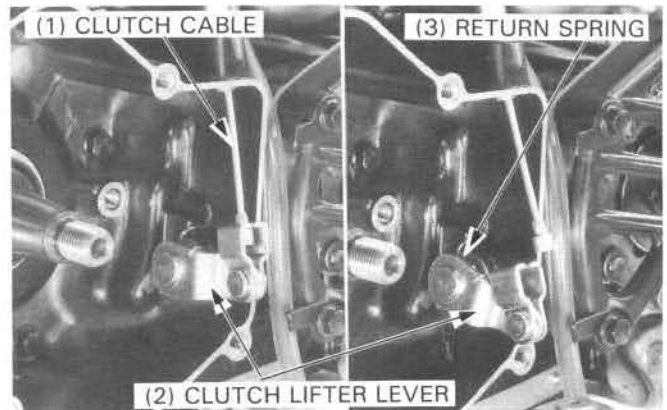

Inspect the following:

- Clutch lifter lever for damage
- Oil seal for wear or damage

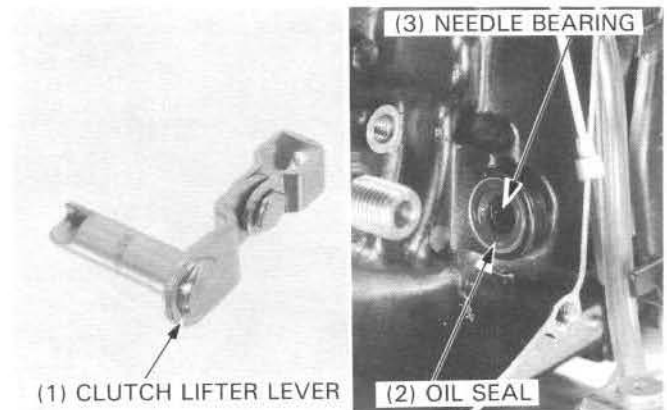

Clutch Lifter Lever Installation

Coat the clutch lifter lever with grease, then install the clutch lifter lever and return spring.

Installation is in the reverse order of removal.

After installation, check the following:

- Ignition timing (page 14-8)
- Clutch operation

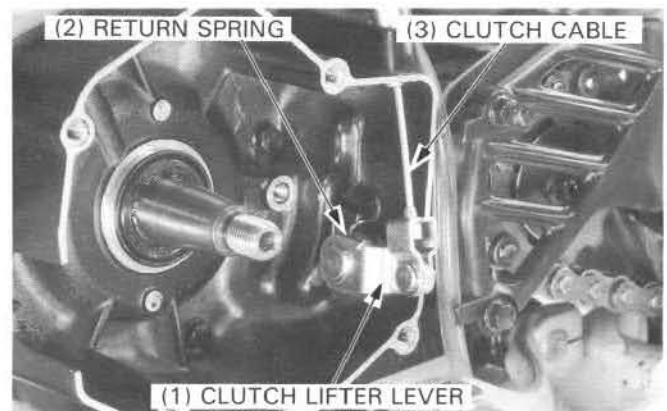

Clutch Installation

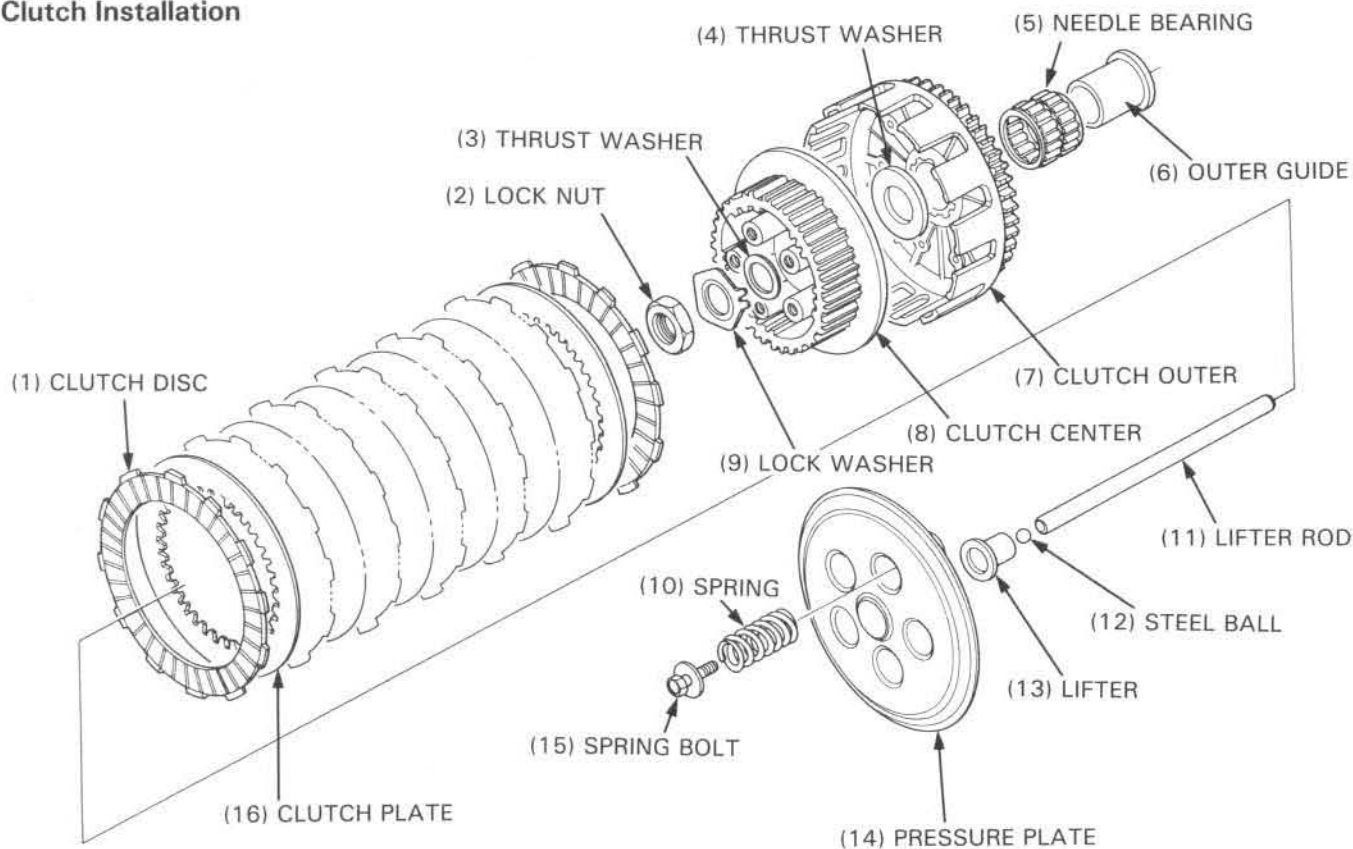

Install the clutch outer guide and needle bearing onto the mainshaft.



Install the clutch outer and thrust washer.

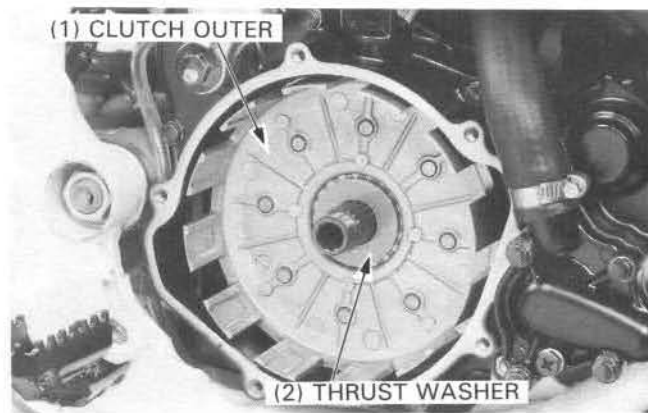

Install the clutch center onto the mainshaft.

Install the thrust washer. Align the groove of a new lock washer with a rib on the clutch center and slip it into place on the mainshaft.

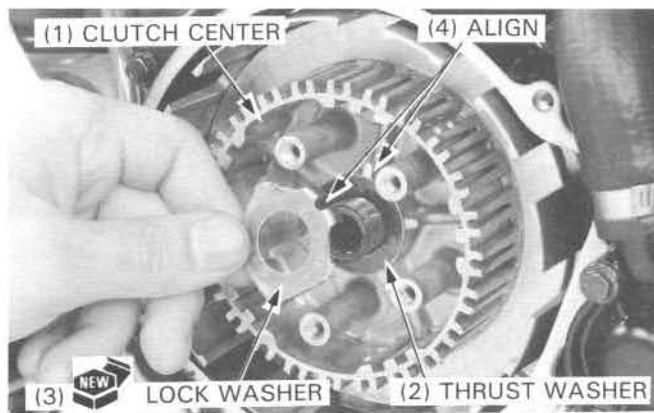

Install the clutch center nut and tighten the nut to the specified torque while holding the clutch center with the clutch center holder.



Clutch center holder 07724-0050001

Torque: 60 N·m (6.0 kg-m, 43 ft-lb)

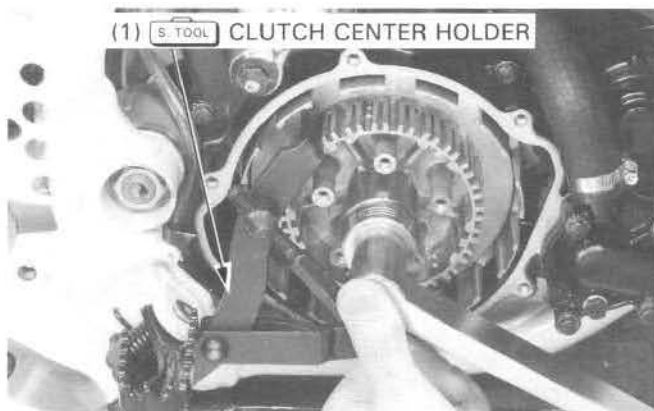

Bend the tabs of the lock washer up against the clutch center nut.

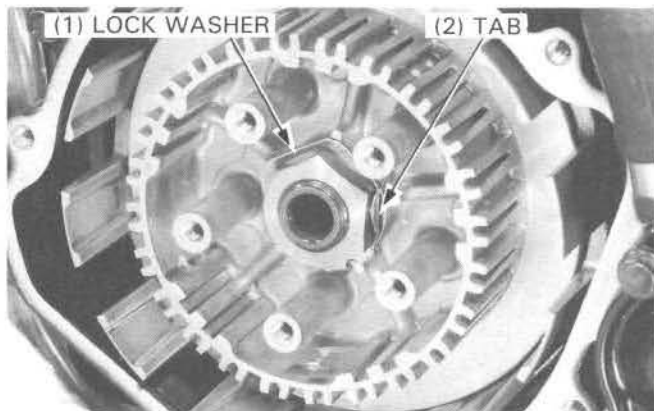

Coat the clutch plates with clean transmission oil.

Install the seven friction discs and six clutch plates alternately, starting with a disc.

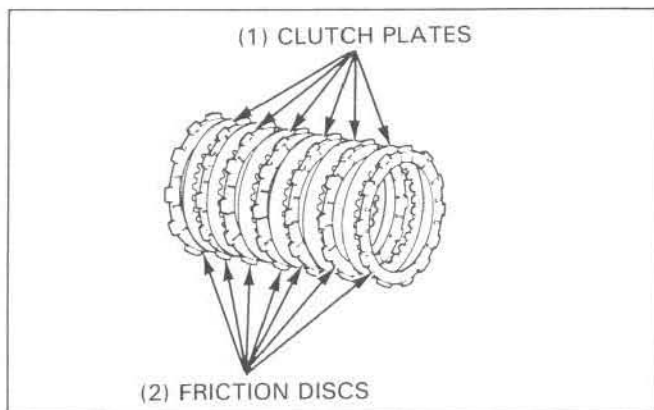

Clutch/Kickstarter/Gearshift Linkage

Apply grease to the steel ball and clutch lifter rod.

Insert the clutch lifter rod into the mainshaft.

Insert the steel ball into the clutch lifter and install the clutch lifter.

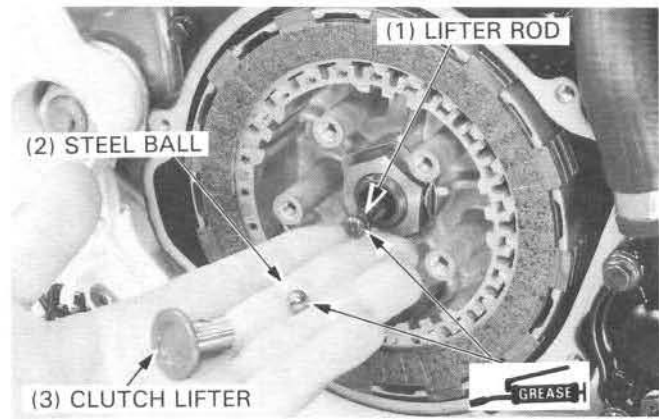

Install the clutch pressure plate.

Install the five springs and spring bolts.

Tighten the bolts in a crisscross pattern in 2 or 3 steps.

Torque: 10 N·m (1.0 kg·m, 7 ft·lb)

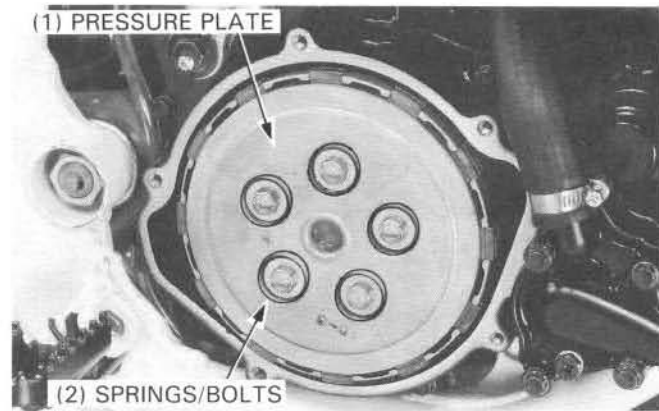

Check that the clutch cover O-ring is in good condition and install the clutch cover.

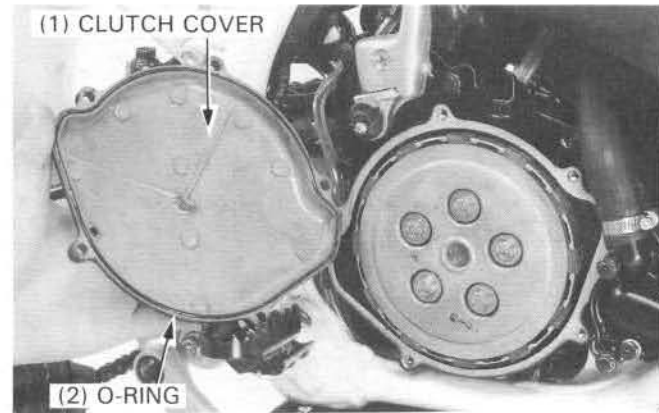

Install and tighten the clutch cover bolts.

Torque: 10 N·m (1.0 kg·m, 7 ft·lb)

Install the brake pedal (page 13-14).

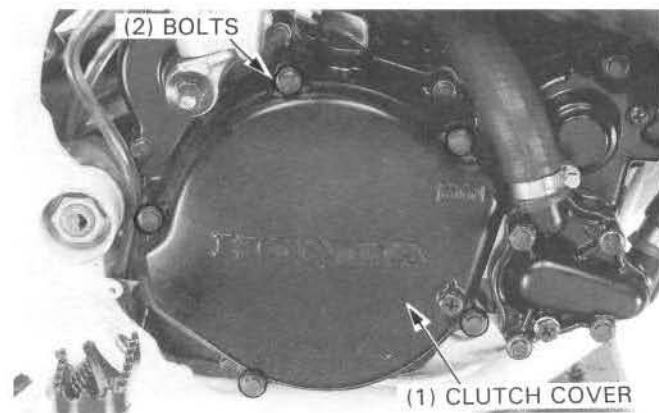

Kickstarter

Removal

Remove the right crankcase cover (page 9-2).

Remove the clutch (page 9-3).

Remove the idle gear and washer.

Unhook the kickstarter return spring from the crankcase, and pull the kickstarter spindle assembly out.

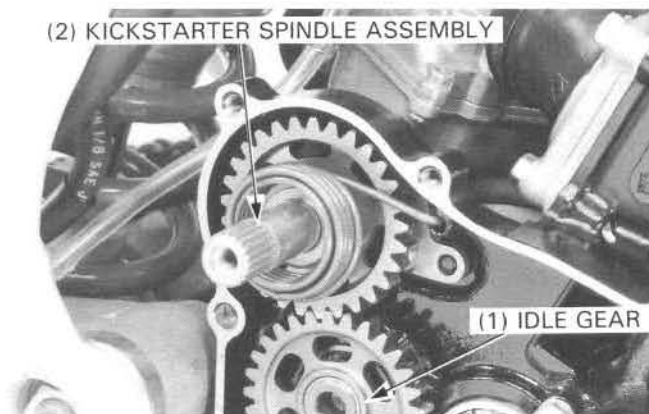

Disassembly

Disassemble the kickstarter spindle by removing the following:

- Thrust washer and collar
- Return spring
- Ratchet spring and starter ratchet
- Snap ring, thrust washers and pinion gear

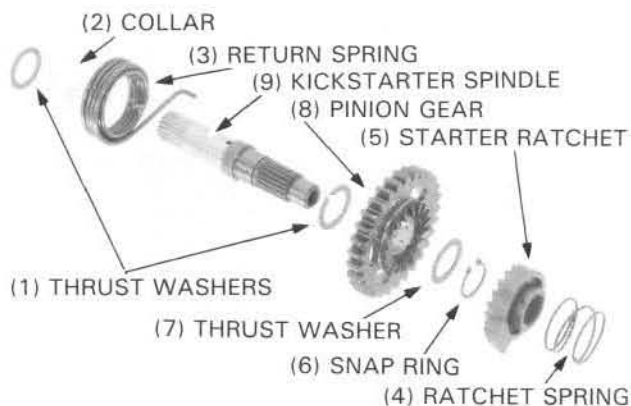

Assembly

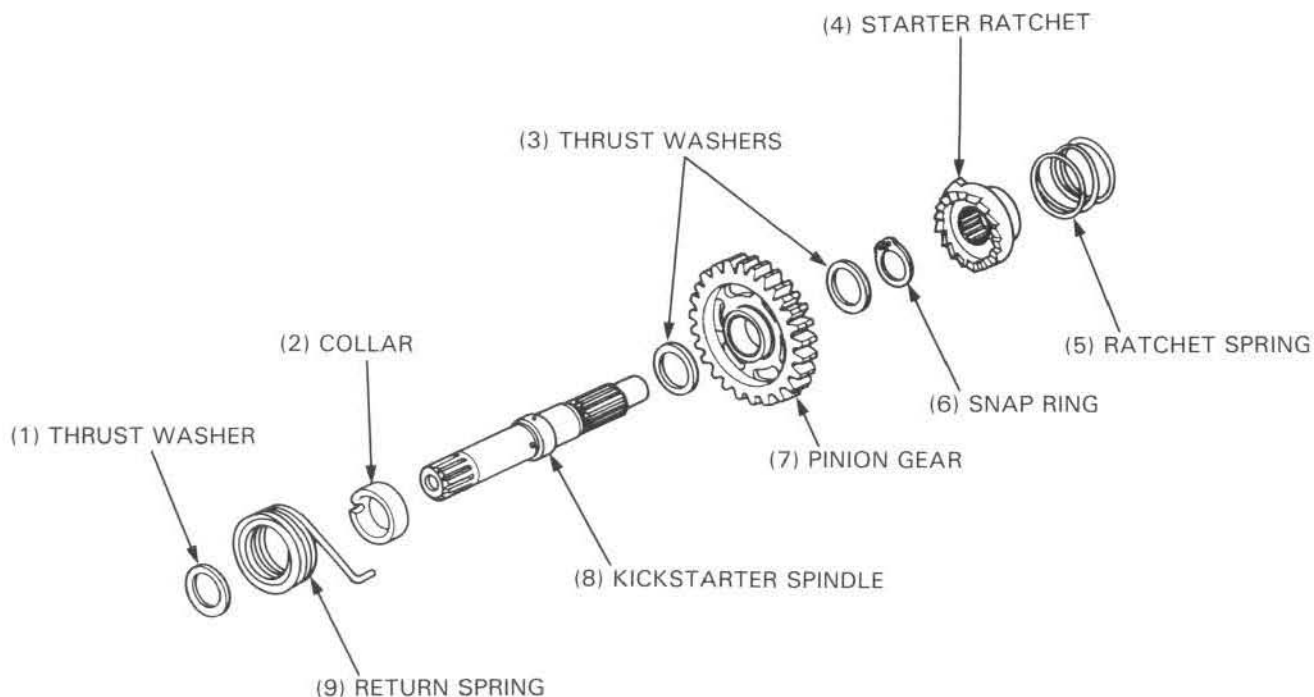

Clutch/Kickstarter/Gearshift Linkage

Insert the return spring into the spring hook of the starter spindle.

Install the collar aligning the groove of the collar with the spring, then install the thrust washer.

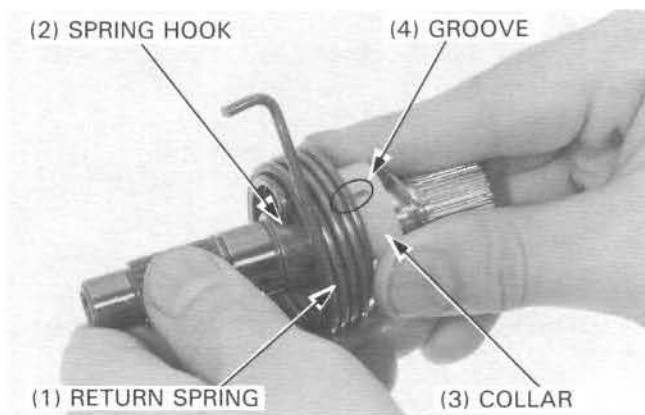

Install the thrust washer and pinion gear.
Install the thrust washer and snap ring.

NOTE

- Seat the snap ring in the groove of the spindle with the sharp edge facing towards the outside.

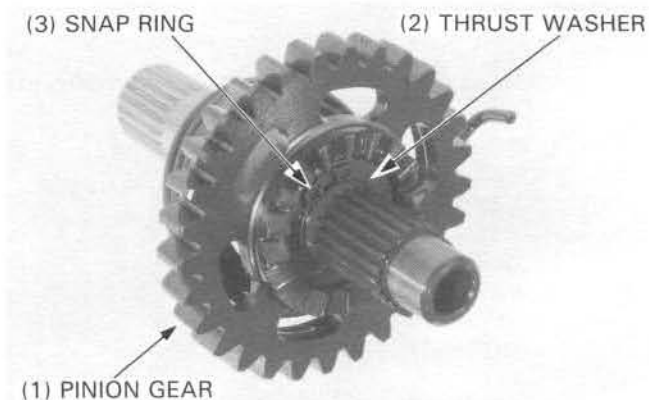

Align the punch marks and install the starter ratchet.
Install the ratchet spring and thrust washer.

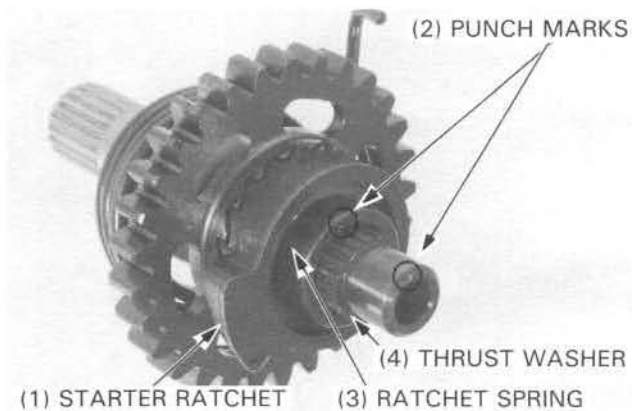

Install the kickstarter spindle and hook the return spring end to the crankcase.



Install the thrust washer onto the countershaft.
Install the starter idle gear onto the countershaft.

Install the following:

- Clutch (page 9-6)
- Right crankcase cover (page 9-2)

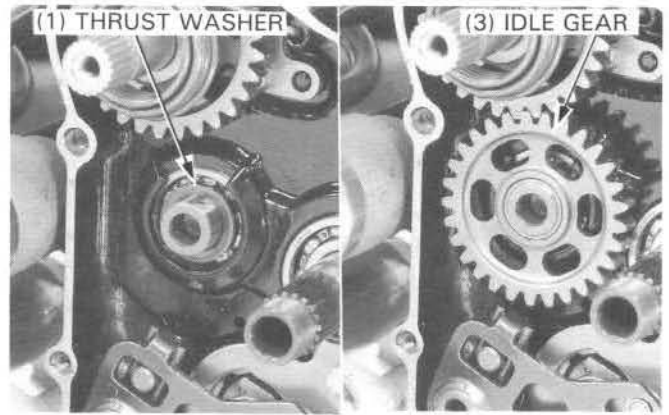

Gearshift Linkage

Removal

Remove the following:

- Right crankcase cover (page 9-2)
- Clutch (page 9-3)

Remove the gearshift pedal and pull the gearshift spindle out.

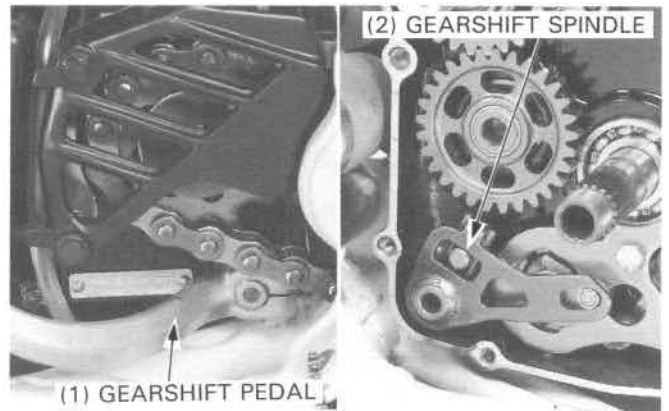

Remove the shifter collar.

Remove the guide plate bolts, the remove the guide plate and drum shifter as an assembly.

NOTE

- Do not let the ratchet pawls fall when removing the guide plate and drum shifter.

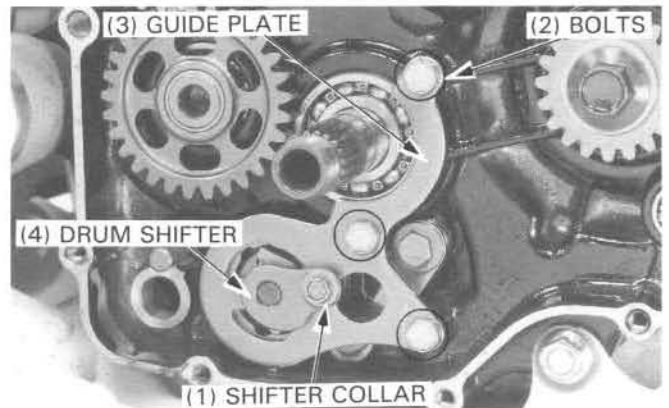

Remove the bolt, stopper arm and return spring.

Remove the shift drum center pin and shift drum center.

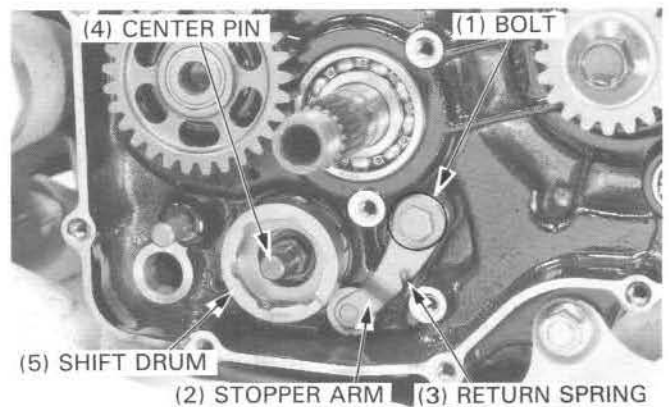

Clutch/Kickstarter/Gearshift Linkage

Installation

Apply clean transmission oil to the ratchet pawls, springs and plunger.

Assemble the drum shifter, springs, plungers and ratchet pawls in the guide plate as shown.

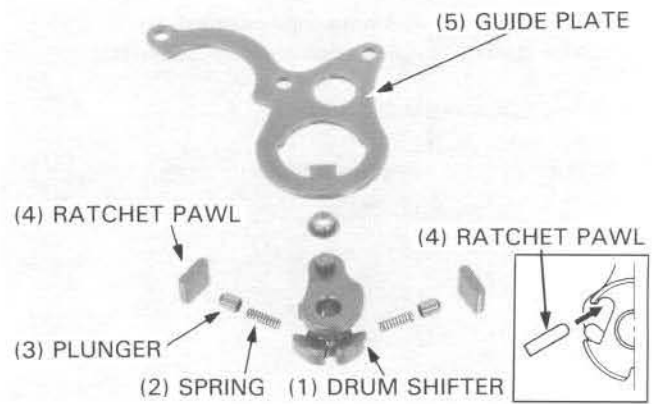

Install the return spring, plain washer and stopper arm and tighten the stopper arm bolt to the specified torque.

Torque: 12 N·m (1.2 kg-m, 9 ft-lb)

Check the stopper arm for proper operation.

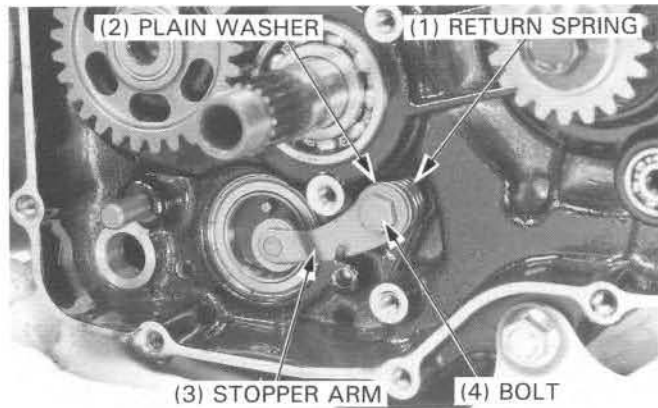

Install the dowel pin into the shift drum.

Move the stopper arm out of the way using a screwdriver. Align the shift drum center hole with the dowel pin and slip it into place.

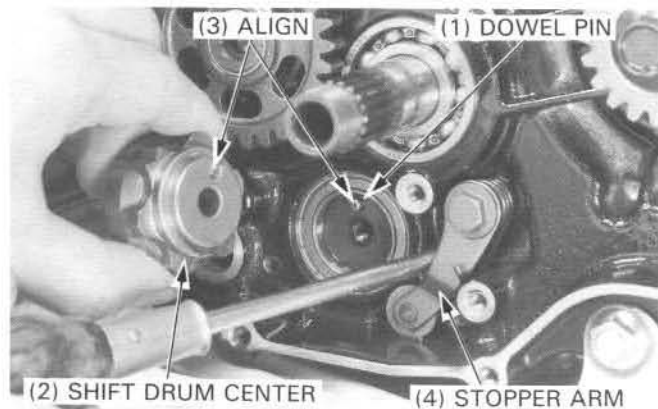

Install and tighten the shift drum center pin.

Torque: 22 N·m (2.2 kg-m, 16 ft-lb)

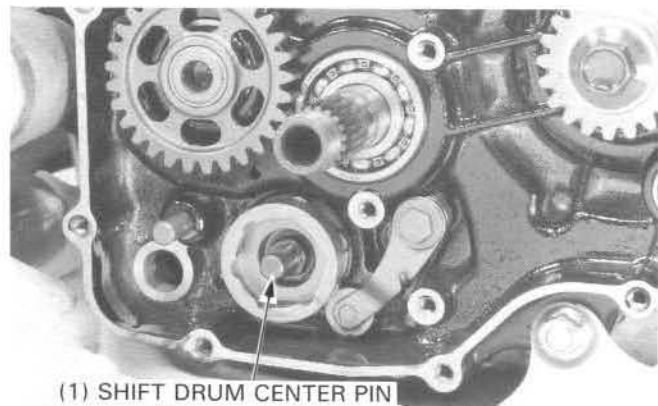

Position the drum center in a detent other than neutral. Holding the ratchet pawls in place in the guide plate and drum shifter, install the assembly onto the shift drum center pin. Install and tighten the guide plate bolts.

Install the shifter collar onto the drum shifter.

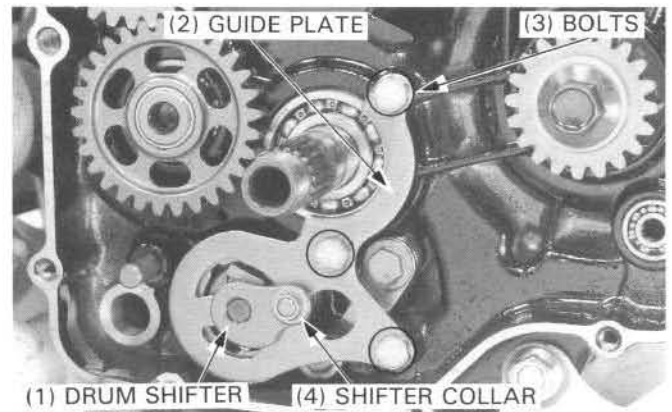

Assemble and install the gearshift spindle.

NOTE

- Do not forget to install the thrust washer onto the gearshift spindle.

Check that the shift drum turns smoothly. Install the gearshift pedal.

Install the following:

- Clutch (page 9-6)
- Right crankcase cover (page 9-2)

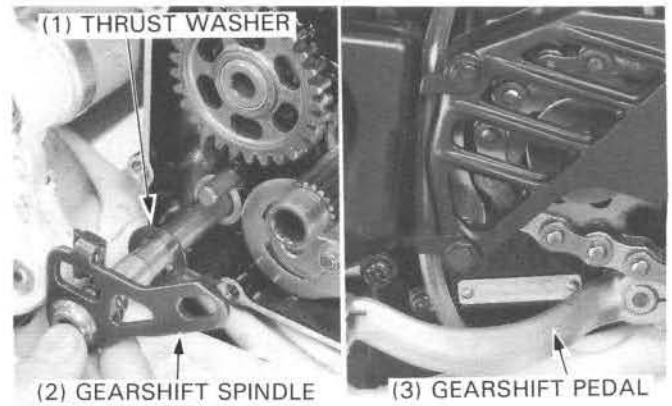

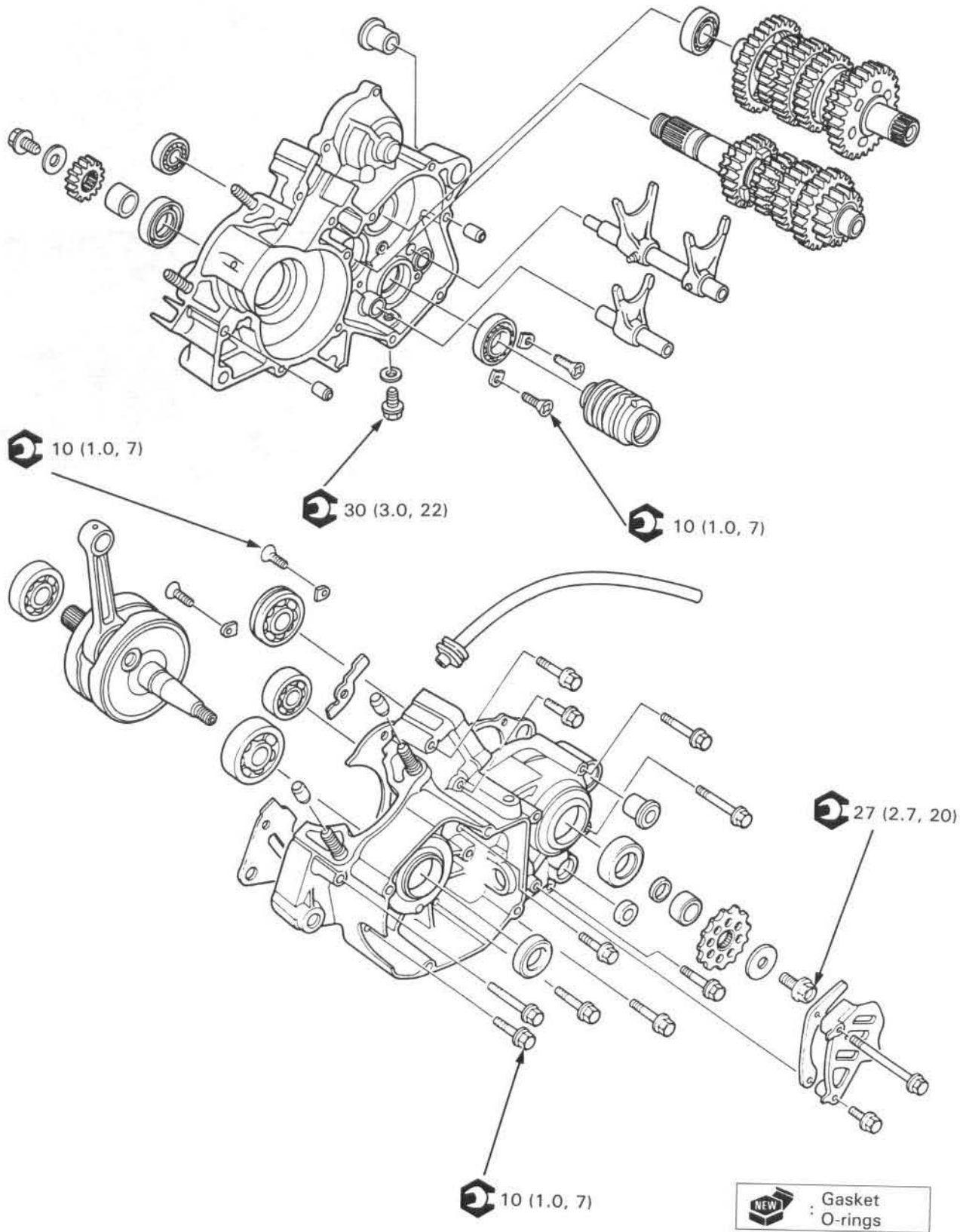

10. Crankcase/Crankshaft/Transmission

Service Information	10-1	Crankcase Bearing Replacement	10-5
Troubleshooting	10-2	Crankshaft Installation	10-8
Crankcase Separation	10-3	Transmission Assembly	10-8
Transmission Disassembly	10-4	Crankcase Assembly	10-10
Crankshaft Removal	10-5		

Service Information

General

- This section covers crankcase separation for service of the crankshaft, transmission and kickstarter.
- The engine must be out of the frame for this service.
- The following parts must be removed before separating the crankcase.
 - Alternator (Section 14)
 - Clutch/kickstarter/gearshift linkage (Section 9)
 - Cylinder head/cylinder/piston (Section 7)

Specifications

Unit: mm (in)

10

Item		Standard	Service Limit
Connecting rod big end	Side clearance	0.4–0.8 (0.02–0.03)	0.9 (0.04)
	Radial clearance	0.022–0.034 (0.0009–0.0013)	0.044 (0.0017)
Crankshaft runout		—	0.05 (0.002)
Transmission gear I.D.	M5, M6	23.020–23.041 (0.9063–0.9071)	23.060 (0.9080)
	C1	20.020–20.041 (0.9063–0.9071)	20.060 (0.7900)
	C2, C3, C4	25.020–25.041 (0.9850–0.9859)	25.060 (0.9870)
Transmission gear bushing O.D.	M5, M6	22.959–22.980 (0.9039–0.9047)	22.940 (0.9030)
	C1	19.979–20.000 (0.7866–0.7874)	19.950 (0.7850)
	C2, C3, C4	24.979–25.000 (0.9834–0.9843)	24.950 (0.9820)
Transmission gear bushing I.D.	M5	20.000–20.021 (0.7874–0.7782)	20.040 (0.7890)
	C1	17.000–17.018 (0.6693–0.6700)	17.030 (0.6700)
	C2, C4	22.000–22.021 (0.8661–0.8670)	22.040 (0.8680)
Gear-to-bushing clearance	M5, M6	0.040–0.082 (0.0016–0.0032)	0.120 (0.0047)
	C1	0.020–0.062 (0.0008–0.0024)	0.110 (0.0043)
	C2, C4	0.020–0.062 (0.0008–0.0024)	0.110 (0.0043)
Mainshaft O.D. at M5 gear		19.959–19.980 (0.7858–0.7866)	19.940 (0.7850)
Countershaft O.D.	At C2, C4 bushing	21.959–21.980 (0.8645–0.8654)	21.940 (0.8638)
	At C1 bushing/ starter idle gear	16.983–16.994 (0.6686–0.6691)	16.970 (0.6681)
Gear bushing-to-shaft clearance	M5	0.020–0.062 (0.0008–0.0024)	0.100 (0.0039)
	C1	0.006–0.035 (0.0002–0.0014)	0.060 (0.0024)
	C2, C4	0.020–0.062 (0.0008–0.0024)	0.100 (0.0039)
Shift fork claw thickness		4.93–5.00 (0.194–0.197)	4.8 (0.19)
Shift fork I.D.		11.041–11.056 (0.4347–0.4353)	11.065 (0.4356)
Shift fork shaft O.D.		10.983–10.994 (0.4324–0.4328)	10.973 (0.4320)

Torque Values

Primary drive gear bolt	45 N•m (4.5 kg-m, 33 ft-lb)
Driver sprocket bolt	27 N•m (2.7 kg-m, 20 ft-lb)
Countershaft bearing set plate bolt	10 N•m (1.0 kg-m, 7 ft-lb) Apply a locking agent
Gearshift drum bearing set plate	10 N•m (1.0 kg-m, 7 ft-lb)

Tool

Special

Crankcase puller	07937-4300000
Universal bearing puller	07631-0010000 or equivalent commercially available in U.S.A.
Crankcase assembly tool set	07965-1660100-Not available in U.S.A. or 07965-1660101 07965-1660200
- Shaft puller	07965-1660300 or 07965-1660301
- Assembly collar	07936-3710300 or equivalent commercially available in U.S.A.
Bearing remover, 17 mm	07936-3710100
- Remover handle	07741-0010201 or 07936-3710200
- Remover weight	07965-KA30000
Threaded adaptor	

Common

Gear holder	07724-0010100
Driver	07746-0010000
Attachment, 32 x 35 mm	07746-0010100
Attachment, 42 x 47 mm	07746-0010300
Attachment, 52 x 55 mm	07746-0010400
Pilot, 17 mm	07746-0040400
Pilot, 20 mm	07746-0040500
Pilot, 22 mm	07746-0041000
Pilot, 25 mm	07746-0040600
Universal holder	07725-0030000 or equivalent commercially available in U.S.A.

Troubleshooting

Engine Noise

- Worn crankpin bearing
- Worn transmission bearing(s)
- Worn crankshaft bearing(s)

Transmission Jumps Out Of Gear

- Worn gear dogs or slots
- Bent fork shaft
- Broken shift drum stopper
- Worn or bent shift forks
- Broken shift linkage return spring

Hard To Shift

- Improper clutch operation
- Incorrect transmission oil
- Incorrect clutch adjustment
- Bent shift fork
- Bent fork shaft
- Bent fork claw
- Damaged shift drum cam grooves
- Bent shift spindle

Engine Vibration

- Excessive crankshaft runout

Crankcase Separation

NOTE

- Refer to Service Information (page 10-1) for removal of necessary parts before separating the crankcase.

Remove the sprocket guard by removing the two bolts.

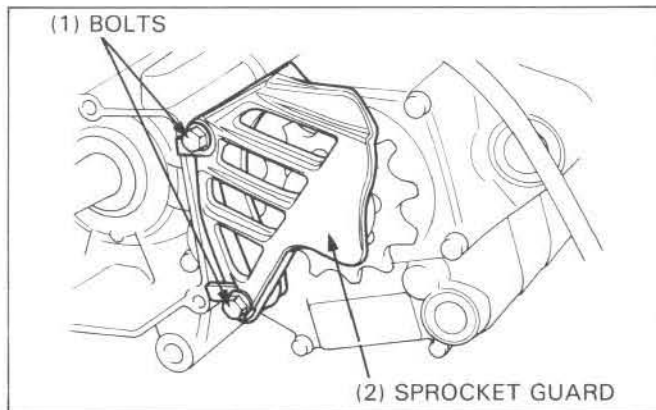

Loosen the drive sprocket bolt while holding the sprocket with the universal holder.



Universal holder

07725-0030000 or Equivalent commercially available in U.S.A.

Remove the cone spring washer and drive sprocket.

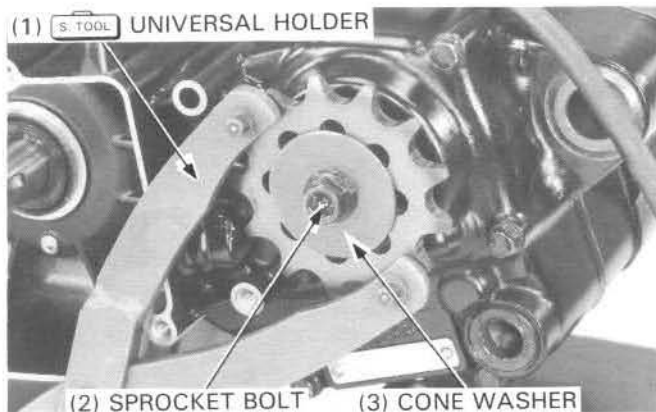

Temporarily install the clutch outer guide, needle bearing and clutch outer onto the mainshaft.

Insert the gear holder between the primary drive and driven gear.

Remove the primary drive gear bolt, then remove the washer and drive gear.



Gear holder

07724-0010100 or Equivalent commercially available in U.S.A.

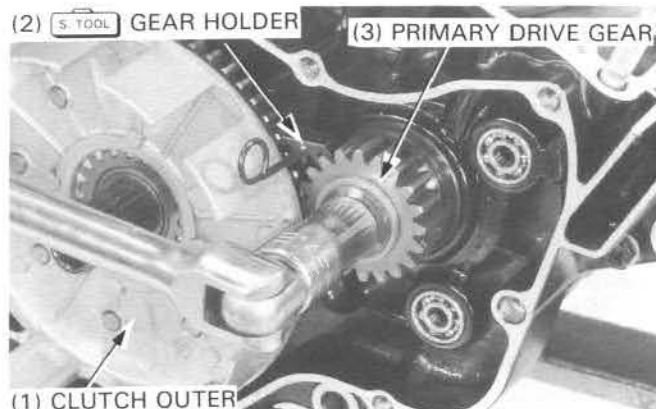

Remove the clutch outer, needle bearing and outer guide.

Remove the collar from the crankshaft.
Remove the countershaft collar.



Crankcase/Crankshaft/Transmission

Loosen the crankcase bolts in a crisscross pattern in 2 or 3 steps, then remove them.

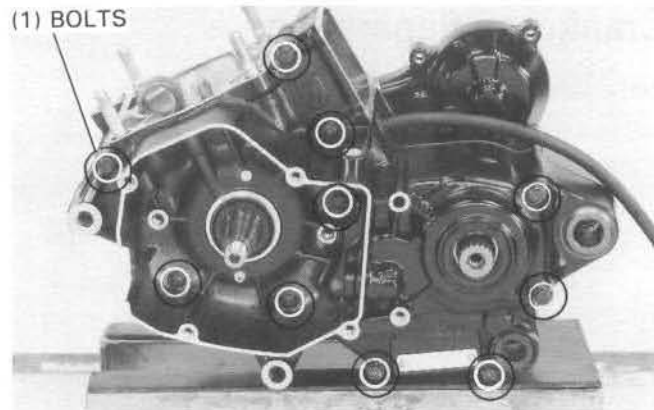

Attach the crankcase puller to the left crankcase and separate the crankcase halves.

NOTE

- Separate the right and left crankcase from each other while tapping them at several locations with a soft hammer.

CAUTION

- Do not pry the crankcase halves apart with a screwdriver.

S. TOOL

Crankcase puller
Threaded adaptor

07937-430000
07965-KA30000

Remove the gasket and dowel pins.

Transmission Disassembly

Separate the crankcase halves (page 10-3).

Remove the shift fork shafts and shift forks.
Remove the shift drum.

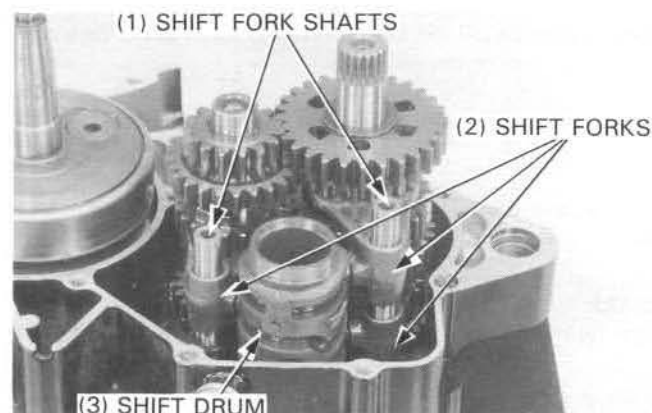
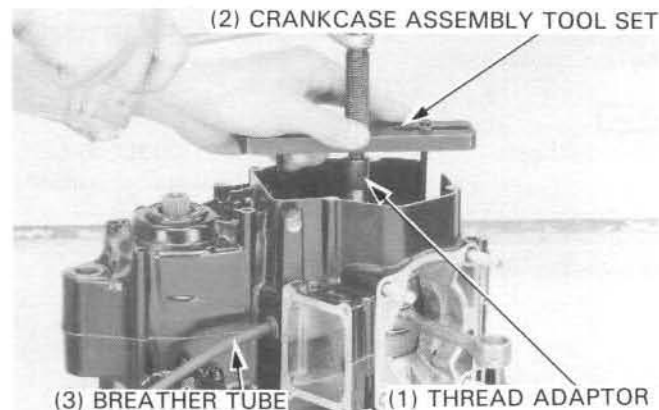

Remove the mainshaft and countershaft assemblies as a set.

Disassemble the mainshaft and countershaft.

Inspect the disassembled parts.
For specifications see page 10-1 of this manual.

(1) MAINSHAFT/COUNTERSHAFT ASSEMBLY

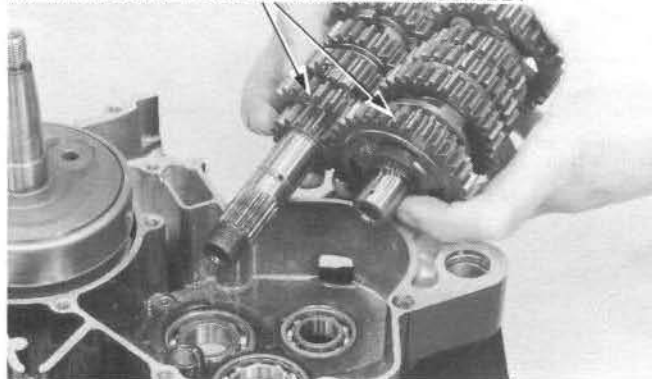

Crankshaft Removal

CAUTION

- When removing, installing and inspecting the crankshaft, be careful not to damage or nick the hollow crank weights.

Separate the crankcase (page 10-3).
Remove the transmission (page 10-4).

Remove the crankshaft from the right crankcase using a hydraulic press as shown.

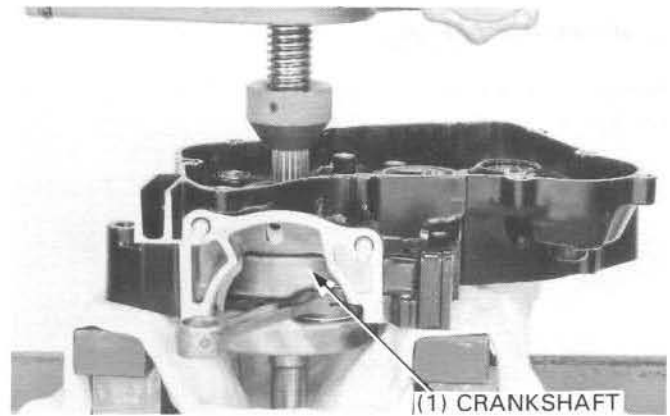

If the crankshaft bearing is removed with the crankshaft, remove the bearing using the bearing puller and discard the bearing.

S. TOOL

Universal bearing puller

07631-0010000 or
Equivalent commercially
available in U.S.A.

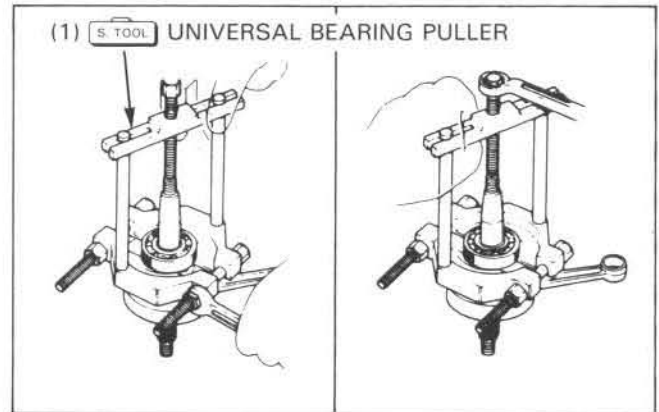

Crankcase Bearing Replacement

Crankcase Bearing/Oil Seal Locations

RIGHT CRANKCASE SIDE:

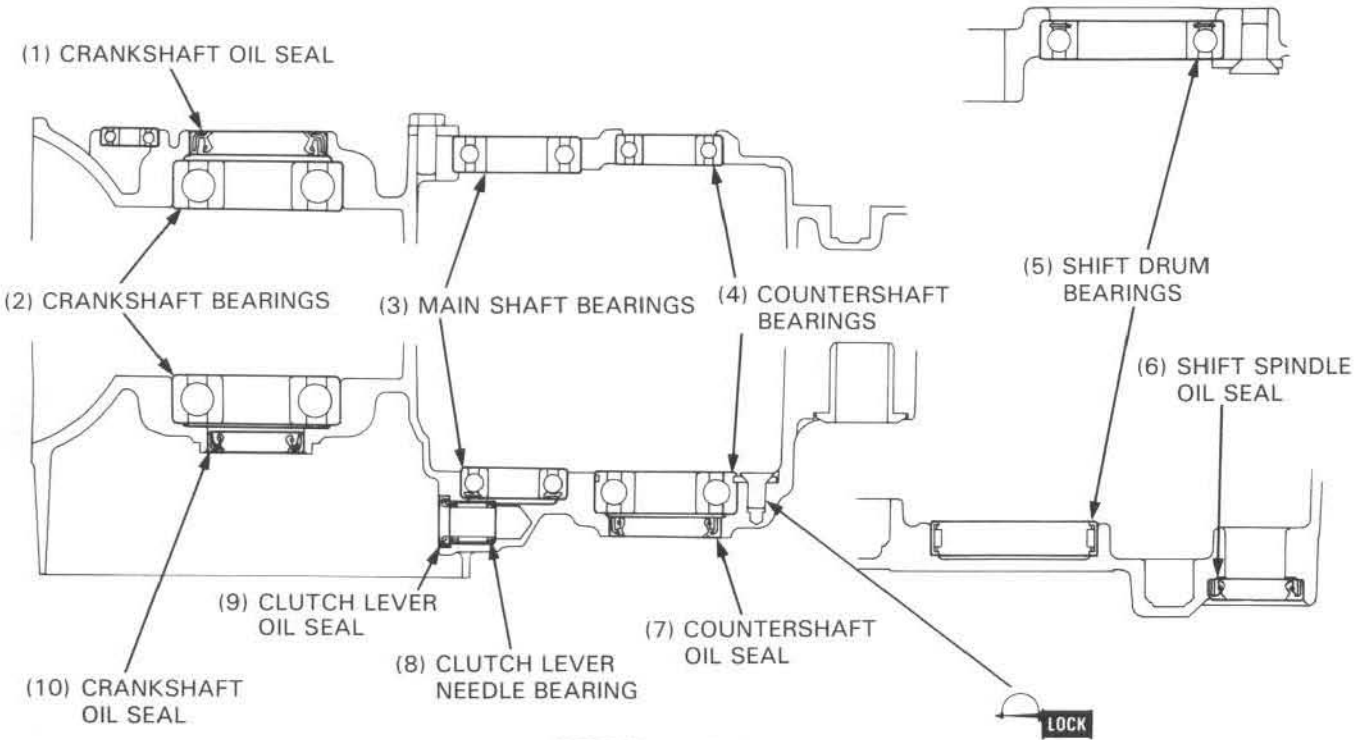

LEFT CRANKCASE SIDE:

Crankshaft Bearings

Remove the crankshaft oil seals and bearings from both crankcase halves.

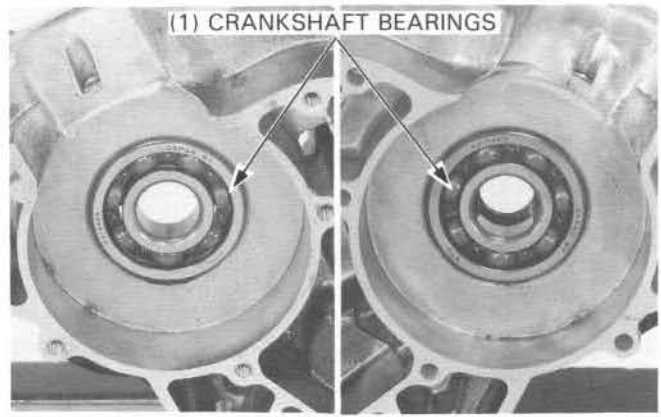

Drive new crankshaft bearings into both cases using the special tools.

S. TOOL

Driver 07749-0010000
Attachment, 52 x 55 mm 07749-0010400

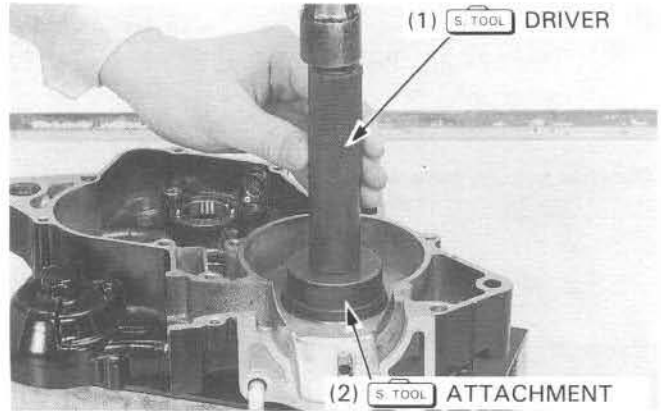

Transmission Bearings

Left Crankcase:

Remove the countershaft oil seal.



Remove the set plates and the countershaft bearing.

Remove the mainshaft bearing using the following tools.

S. TOOL

Bearing remover, 17 mm 07936-3710300 or
Equivalent commercially
available in U.S.A. 07936-3710100
- Remover handle 07741-0010201 or
- Remover weight 07936-3710200

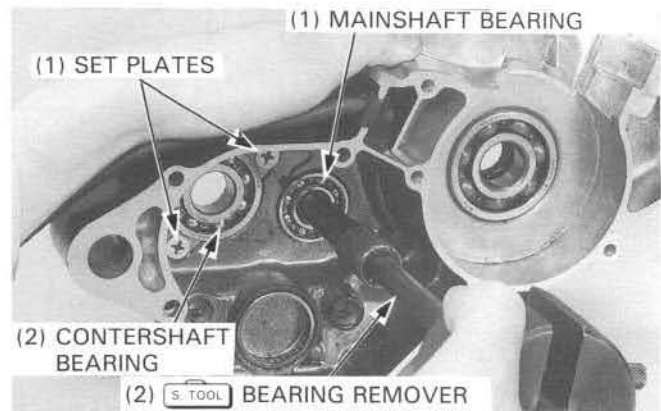

Remove the shift drum bearing.

Drive new bearings into the left crankcase using the special tools.

S TOOL

Shift drum bearing:

Driver 07749-0010000
Attachment, 37 x 40 mm 07746-0010200

Mainshaft bearing:

Driver 07749-0010000
Attachment, 37 x 40 mm 07746-0010200
Pilot, 17 mm 07746-0040400

Countershaft bearing:

Driver 07749-0010000
Attachment, 52 x 55 mm 07746-0010400

Apply a locking agent to the countershaft bearing set plate screws.

Then torque the screws against the set plates.

Torque: 10 N·m (1.0 kg-m, 7 ft-lb)

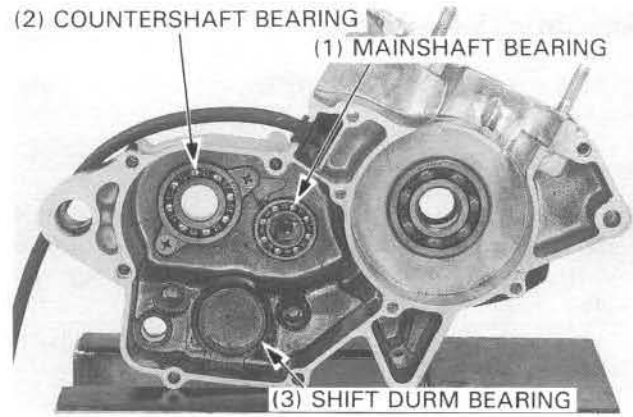

Right Crankcase:

Remove the mainshaft and countershaft bearings.

Remove the shift drum bearing set plates and drive out the shift drum bearing.

Drive new bearings into the right crankcase using special tools.

S TOOL

Mainshaft bearing:

Driver 07749-0010000
Attachment, 52 x 55 mm 07746-0010400
Pilot, 25 mm 07746-0040600

Countershaft bearing:

Driver 07749-0010000
Attachment, 37 x 40 mm 07746-0010200
Pilot, 17 mm 07746-0040400

Shift drum bearing:

Driver 07749-0010000
Attachment, 37 x 40 mm 07746-0010200
Pilot, 25 mm 07746-0040600

Apply a locking agent to the shift drum bearing set plate screws.

Then torque the screws against the set plates.

Torque: 10 N·m (1.0 kg-m, 7 ft-lb)

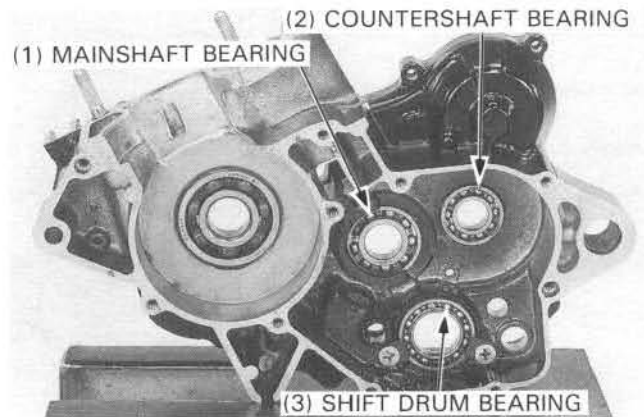

Crankshaft Installation

Clean both crankcase mating surfaces and check for wear or damage before assembling.

NOTE

- If there is minor roughness or irregularities on the crankcase mating surfaces, dress them with an oil stone.
- After cleaning, lubricate the crankshaft bearings with clean 2-stroke oil of the recommended type.

Install the threaded adaptor onto the crankshaft.



Threaded adaptor **07965-KA30000**

Install the crankshaft into the right crankcase using the special tool.



Crankcase assembly tool set **07965-1660100** or
07965-1660101 Not
 available in U.S.A.
07965-1660200
 — Assembly shaft **07965-1660300** or
 — Assembly collar **07965-1660301**

(1) **THREAD ADAPTOR**

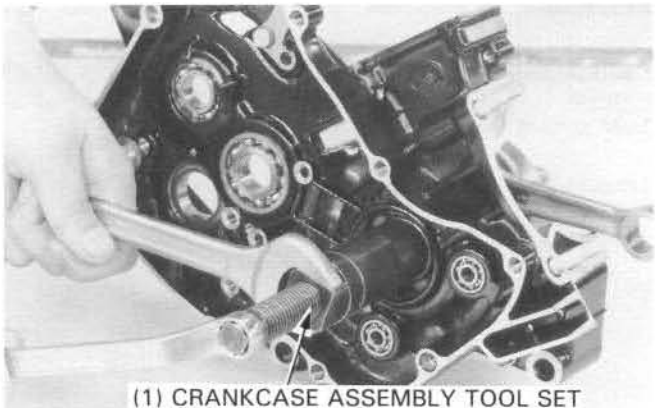
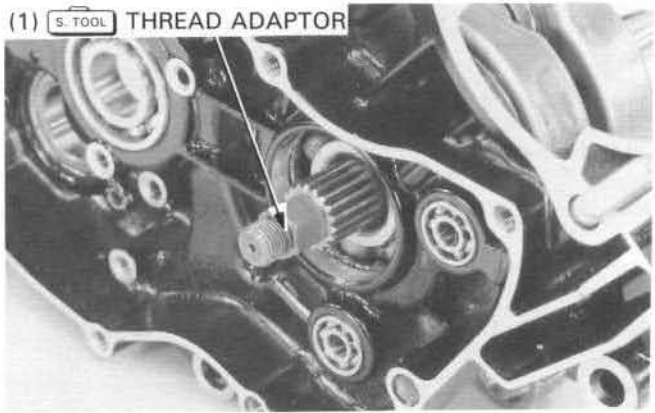

(1) **CRANKCASE ASSEMBLY TOOL SET**

Transmission Assembly

Assemble the transmission.

Mainshaft:

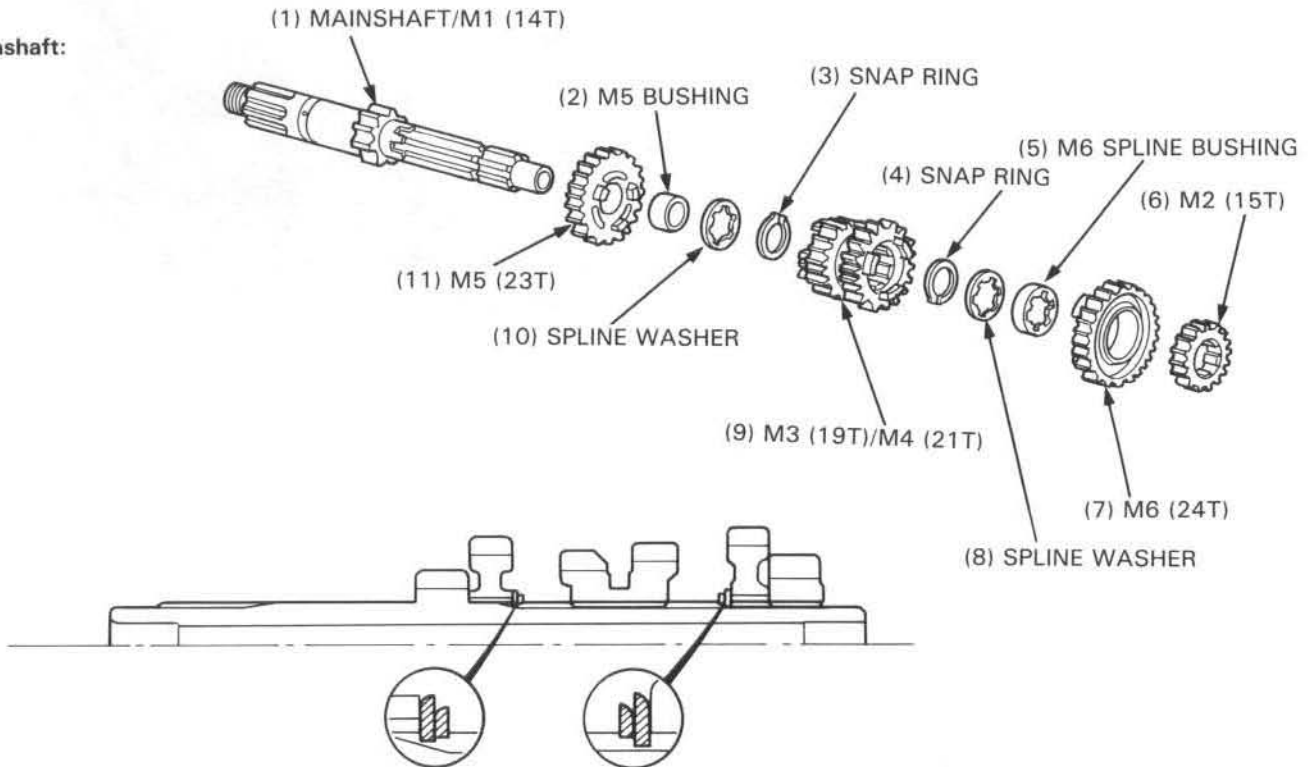

Countershaft:

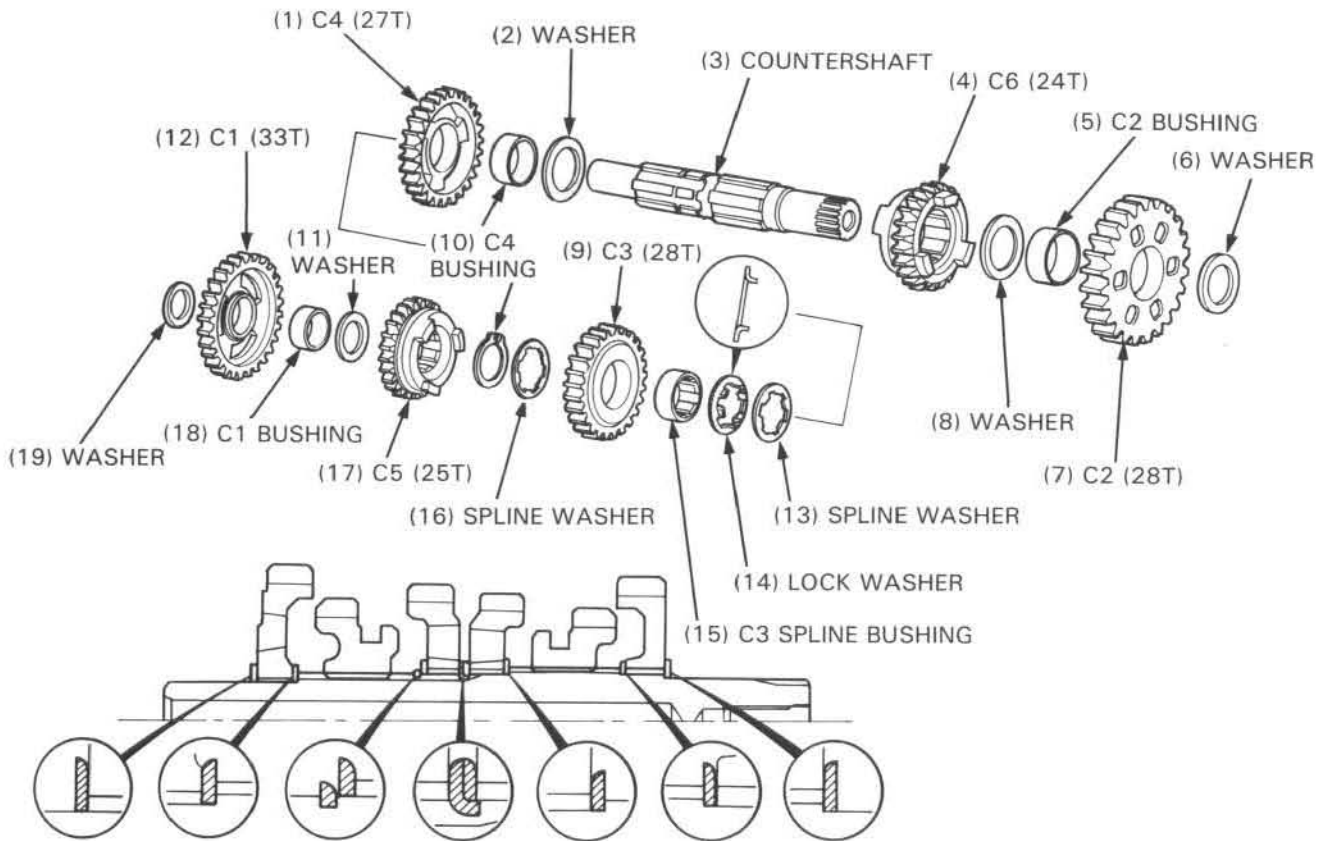

Coat each gear with clean transmission oil and check for smooth movement.

Engage the mainshaft and countershaft gears and place the transmission assembly into the right crankcase.

(1) MAINSHAFT/COUNTERSHAFT ASSEMBLY.

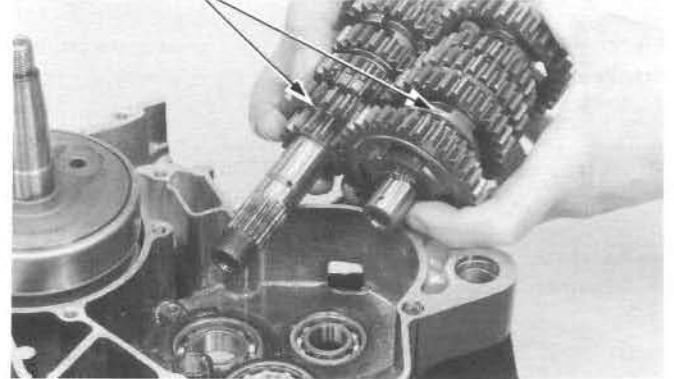

Install the shift forks into the shifter gear grooves.

NOTE

- Install the shift forks with their marks facing toward the right crankcase.

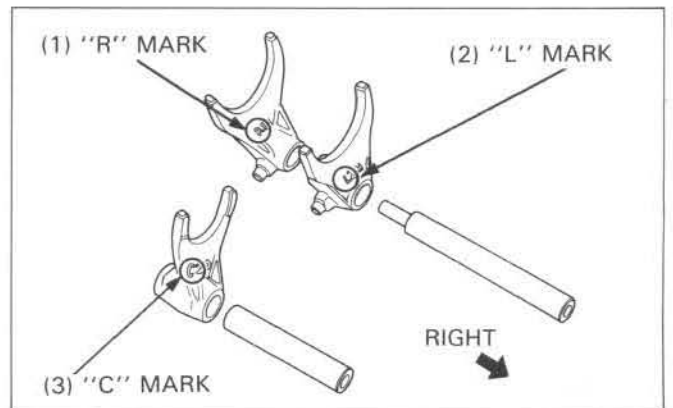

Crankcase/Crankshaft/Transmission

Slide the shift fork shafts through the shift forks, and into the crankcase.

After installation, check for smooth transmission operation.

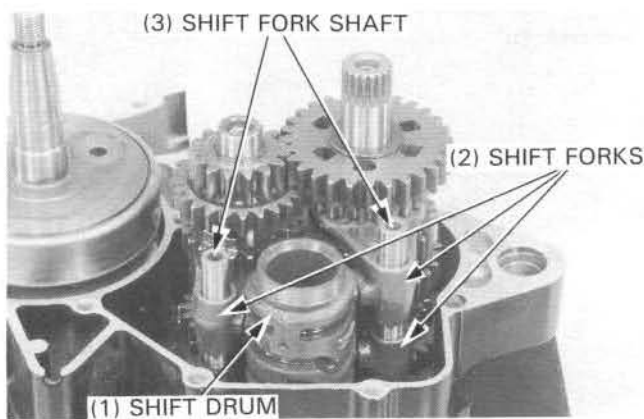

Crankcase Assembly

NOTE

- Before assembly, lubricate the transmission bearings with clean transmission oil.

Install the dowel pins and new gasket.

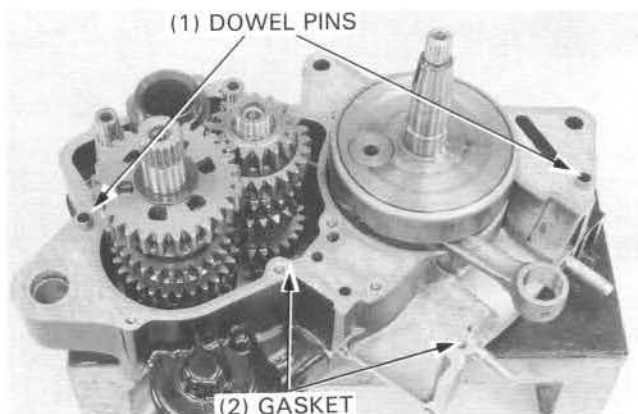

Install the crankcase breather onto the left crankcase.

Place the left crankcase onto the right crankcase using the crankcase assembly tool.

S. TOOL

- Crankcase assembly tool set** 07965-1660100 or
07965-1660101 Not
available in U.S.A.
- Assembly shaft 07965-1660200
— Assembly collar 07965-1660300 or
07965-1660301

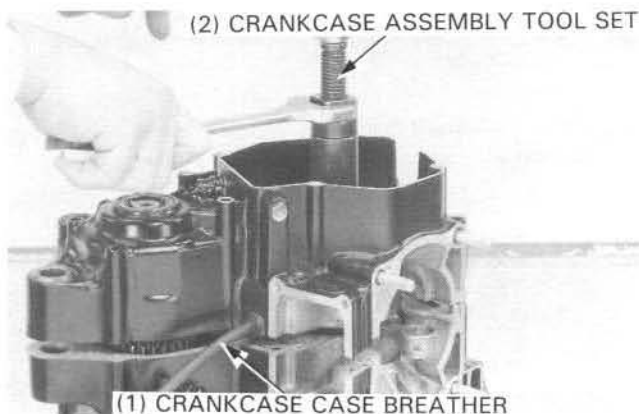

Pack multi-purpose grease into the cavity of the oil seal lips.

Press the oil seals into the crankcase using the crankcase assembly tool until seals are flush with the case as shown.

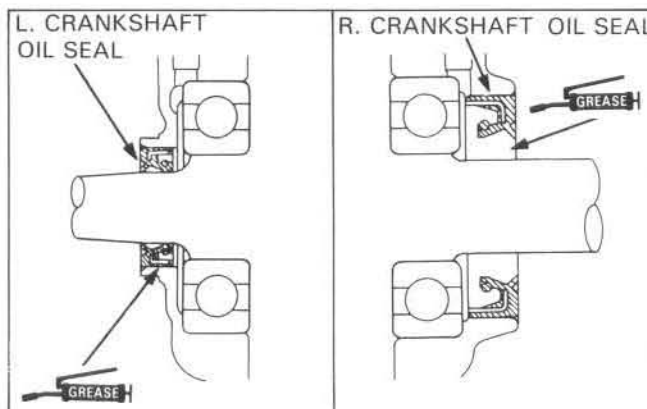

Install and tighten the crankcase bolts in a crisscross pattern in 2 or 3 progressive steps.

Carefully trim the protruding gasket material from the cylinder base gasket surface.

CAUTION

- Do not let gasket material fall into the crankcase.
- Do not damage the base gasket surface.

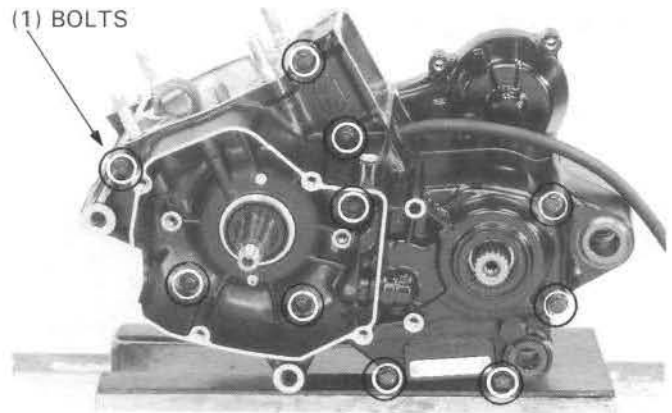

Coat the countershaft O-ring and the inside of the countershaft collar with grease. Install the O-ring and collar onto the countershaft.

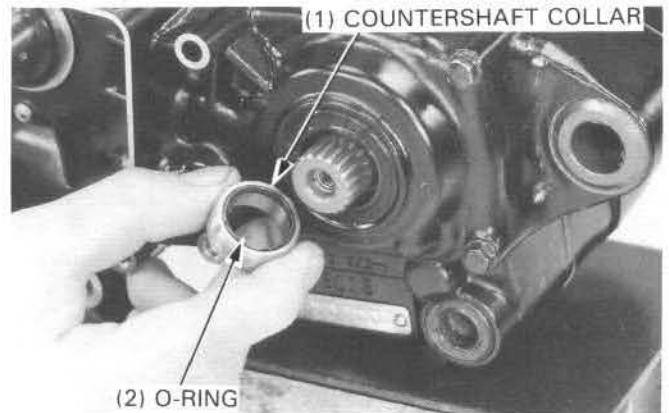

Install the drive sprocket onto the countershaft as described below and at right.

CAUTION

- Install the drive sprocket with its flat side facing the outside.

Install the cone washer with the "OUTSIDE" mark facing out. Hold the drive sprocket with the universal holder and install and tighten the sprocket bolt to the specified torque.



Universal holder

07725-0030000 or
Equivalent commercially
available in U.S.A.

Torque: 27 N·m (2.7 kg-m, 20 ft-lb)

Install the drive sprocket guard and tighten the bolts.

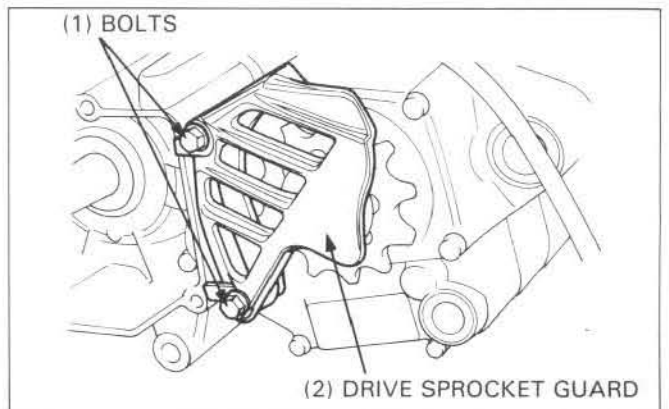
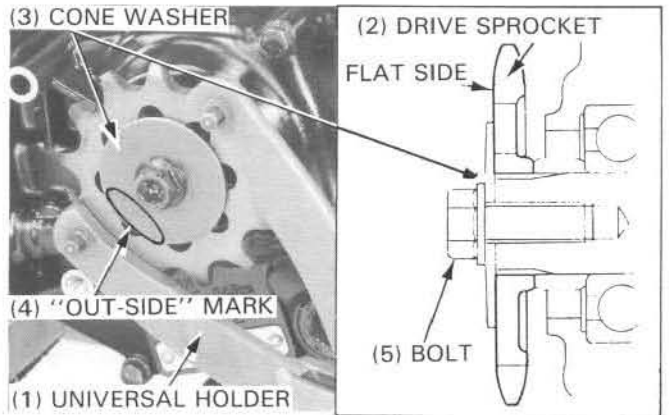

Crankcase/Crankshaft/Transmission

Install the collar onto the crankshaft.



Install the primary drive gear and washer.

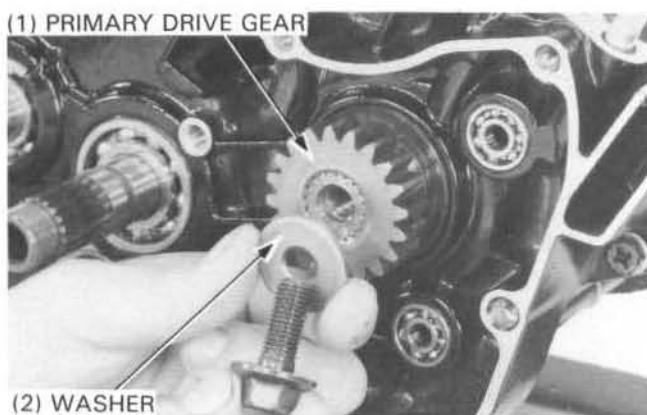

Temporarily install the clutch outer guide, needle bearing and clutch outer onto the mainshaft.

Attach the gear holder between the primary drive and driven gear.

 S TOOL

Gear holder

**07724-0010100 or
Equivalent commercially
available in U.S.A.**

Install and tighten the primary drive gear bolt to the specified torque.

Torque: 45 N·m (4.5 kg-m, 33 ft-lb)

Install the remaining parts in the reverse order of removal.

NOTE

- Refer to Service Information (page 10-1) for installation of parts referenced.

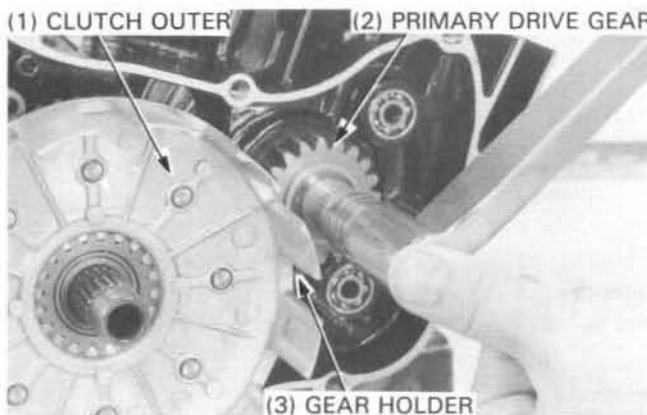

MEMO

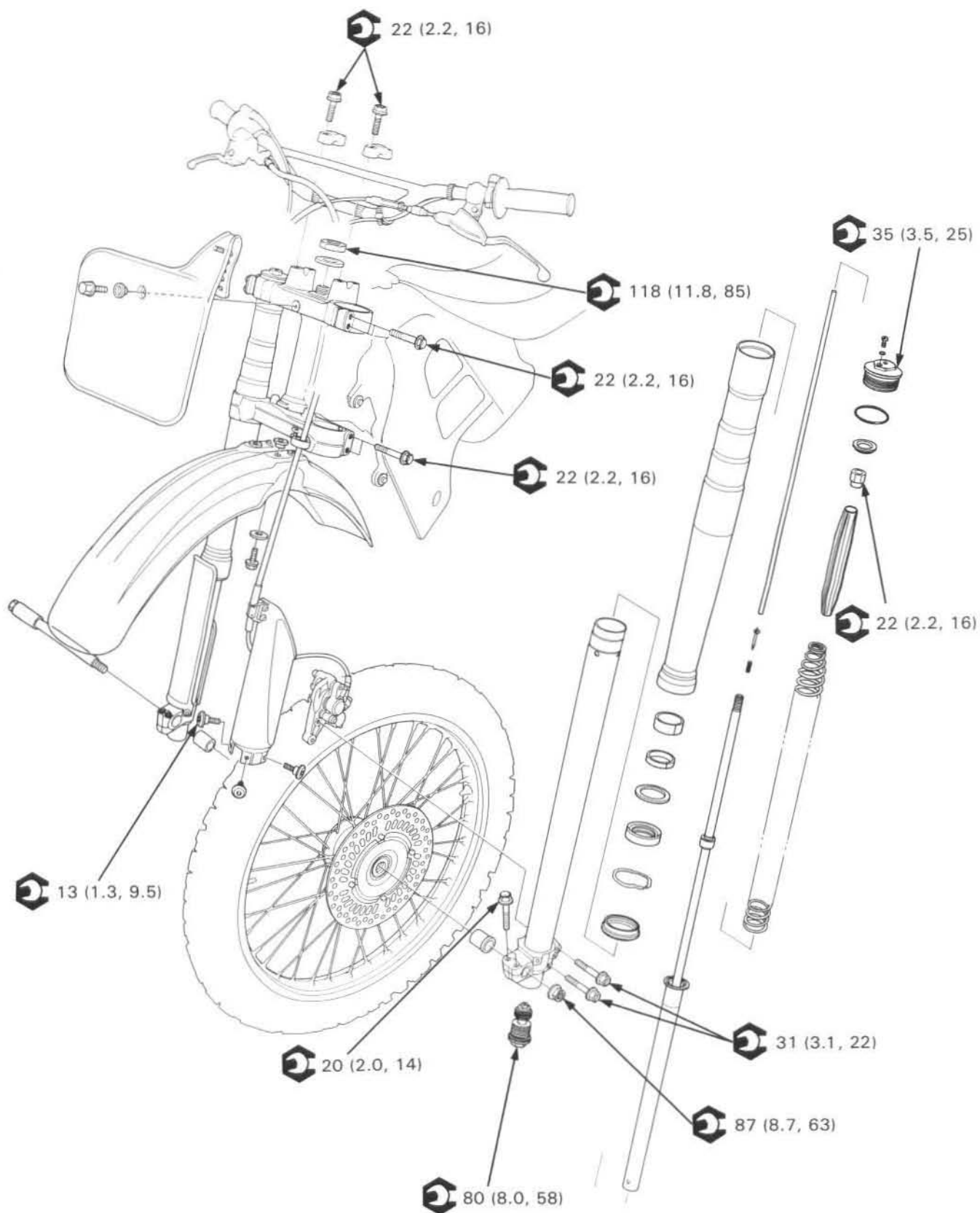

11. Front Wheel/Suspension/Steering

Service Information	11-1	Fork	11-9
Troubleshooting	11-3	Handlebar	11-19
Front Wheel	11-4	Steering Stem	11-22

Service Information

General

Brake dust may contain asbestos fibers.
Never use an air hose or dry brush to clean brake assemblies.

⚠ WARNING

- Inhaled asbestos fibers have been found to cause respiratory disease and cancer.

Keep grease off of brake pads and disc.

⚠ WARNING

- A contaminated brake disc or pads reduces stopping power. Discard contaminated pads and clean a contaminated disc with Pro Honda Contact/Brake Cleaner or an equivalent high quality brake degreasing agent.

- This section covers maintenance of the front wheel, fork and steering stem.
- Optional lighter and heavier than standard springs are available. Refer to General Information, Section 1 for details.
- A box or work stand is required to support the motorcycle.
- For optimum fork performance, the fork should be completely disassembled and cleaned after the first three hours of riding. Thereafter it should be disassembled and cleaned on a regular basis to ensure maximum performance and service life from the internal parts.
- Refer to the section 13 for brake system information.

Specifications

Unit: mm (in)

Item		Standard	Service Limit
Axle runout		—	0.20 (0.008)
Wheel rim runout	Radial	—	2.0 (0.08)
	Axial	—	2.0 (0.08)
Fork spring free length (Standard)		512.0 (20.16)	504.5 (19.86)
Fork tube runout		—	0.2 (0.01)
Recommended fork oil		Pro Honda Suspension Fluid SS-7M or equivalent	
Fork oil level	Standard	106 (4.2)	—
	Adjustable range: Max.	92 (3.6)	—
	Adjustable range: Min.	123 (4.8)	—
Fork oil capacity	Standard	571 cc (19.31 US oz, 20.04 Imp oz)	
	Adjustable range: Max.	585 cc (19.78 US oz, 20.53 Imp oz)	
	Adjustable range: Min.	553 cc (18.70 US oz, 19.41 Imp oz)	

Torque Values

Front axle holder bolt	20 N·m (2.0 kg-m, 16 ft-lb)	
Front axle nut	87 N·m (8.7 kg-m, 63 ft-lb)	
Front brake disc mounting bolt	20 N·m (2.0 kg-m, 16 ft-lb)	
Spoke nipple	3.8 N·m (0.38 kg-m, 2.8 ft-lb)	
Rim lock	13 N·m (1.3 kg-m, 9.5 ft-lb)	
Handlebar holder bolt	22 N·m (2.2 kg-m, 16 ft-lb)	
Front master cylinder holder bolt	10 N·m (1.0 kg-m, 7 ft-lb)	
Clutch lever holder bolt	10 N·m (1.0 kg-m, 7 ft-lb)	
Clutch lever pivot bolt	2 N·m (0.20 kg-m, 1.5 ft-lb)	
Clutch lever pivot lock nut	10 N·m (1.0 kg-m, 7 ft-lb)	
Throttle housing bolt	10 N·m (1.0 kg-m, 7 ft-lb)	
Throttle housing cover screw	1.5 N·m (0.15 kg-m, 1.1 ft-lb)	
Engine stop switch screw	1.5 N·m (0.15 kg-m, 1.1 ft-lb)	
Front brake caliper mounting bolt	31 N·m (3.1 kg-m, 22 ft-lb)	Apply a locking agent
Fork cap	35 N·m (3.5 kg-m, 25 ft-lb)	
Fork cap lock nut	22 N·m (2.2 kg-m, 16 ft-lb)	
Fork center bolt	80 N·m (8.0 kg-m, 58 ft-lb)	
Fork protector mounting bolt	13 N·m (1.3 kg-m, 9.5 ft-lb)	Apply a locking agent
Fork pinch bolt	22 N·m (2.2 kg-m, 16 ft-lb)	Top
	22 N·m (2.2 kg-m, 16 ft-lb)	Bottom
Steering stem nut	118 N·m (11.8 kg-m, 85 ft-lb)	
Steering stem adjusting nut	2 N·m (0.2 kg-m, 1.4 ft-lb)	

Tools

Special

Spoke nipple wrench	07JMA—MR60100 or equivalent commercially available in U.S.A.
Ball race remover	07953—4250002 or 07953—MJ1000A
Steering stem driver	07946—MB00000
Steering stem socket	07916—KA50100
Ball race remover	07948—4630100
Oil seal driver	07KMD—KD30100
Oil seal driver attachment	07NMD—KZ30100
Fork slider spacer	07KMZ—KZ30100

Common

Driver	07749—0010000
Attachment, 32 x 35 mm	07746—0010100
Attachment, 42 x 47 mm	07746—0010300
Attachment, 52 x 55 mm	07746—0010400
Pilot, 17 mm	07746—0040400
Bearing remover head, 17 mm	07746—0050500 or equivalent commercially available in U.S.A.
Bearing remover shaft	07746—0050100
Spanner C, 5.8 x 6.1 mm	07701—0020300

Troubleshooting

Hard Steering

- Steering adjusting nut too tight
- Faulty steering head bearings
- Insufficient tire pressure

Steers To One Side Or Does Not Track Straight

- Bent fork tube
- Bent front axle
- Wheel installed incorrectly
- Unequal oil quantity in each fork tube
- Faulty steering head bearings
- Bent frame
- Worn wheel bearing
- Worn swingarm pivot components

Front Wheel Wobbling

- Bent rim
- Worn front wheel bearings
- Bent spokes
- Faulty tire
- Axle not tightened properly

Soft Suspension

Insufficient fluid in fork

- Fork oil viscosity too thin
- Weak fork springs—if free length is OK, go to optional stiffer spring

Hard Suspension

- Fork oil level too high (too much oil)
- Fork oil viscosity too thick
- Fork tube(s) bent and/or fork slider(s) are damaged

Front Suspension Noisy

- Slider binding
- Insufficient fluid in fork
- Loose fork fasteners

Front Wheel

Removal

Remove the axle nut and loosen the axle pinch bolts.

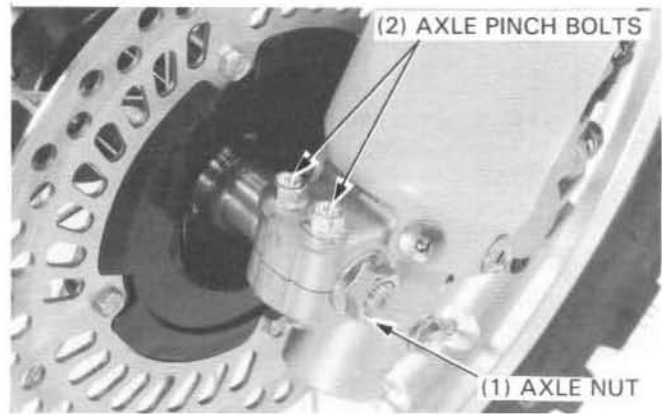

Remove the axle, then remove the front wheel.

NOTE

- Do not depress the brake lever after the front wheel is removed. The caliper piston will move out and make reassembly difficult.

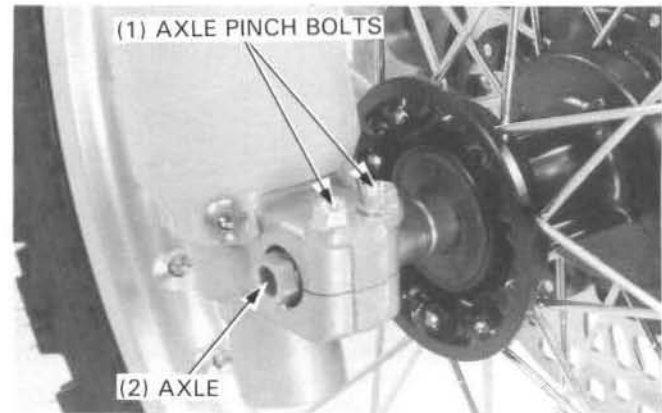

Disassembly

Remove the following:

- Left side collar
- Dust seal
- Brake disc bolts and disc
- Wheel hub cover

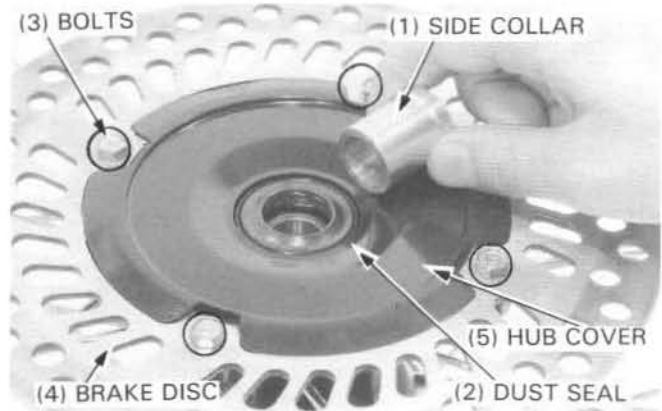

- Right side collar
- Dust seal

If necessary, remove the tire, tube, rim band and the rim lock.

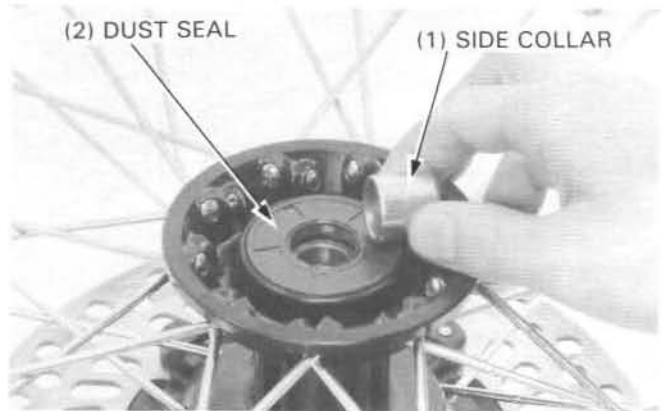

Inspection

Axle

Set the axle in V blocks and measure the runout. Actual runout is 1/2 the total indicator reading.

Service Limit: 0.20mm (0.008 in)

Wheel Bearings

Turn the inner race of each bearing with you finger. The bearings should turn smoothly and quietly. Also check that the bearing outer races fit tightly in the hub.

Remove and discard the bearings if the races do not turn smoothly, quietly, or if they fit loosely in the hub.

NOTE

- Replace wheel bearings in pairs.

Wheel Rim

Check the rim runout by placing the wheel on a turning stand. Then rotate the wheel by hand, and read the runout using a dial indicator. Actual runout is 1/2 the total indicator reading.

Service Limit: Radial: 2.0mm (0.08 in)

Axial: 2.0 mm (0.08 in)

Check the spokes and tighten any that are loose.



Spoke nipple wrench

07JMA—MR60100 or Equivalent commercially available in U.S.A.

Torque: 3.8 N·m (0.38 kg·m, 2.8 ft·lb)

Remove the wheel bearings and distance collar from the wheel hub.



Bearing remover head, 17 mm

07746—0050500 or Equivalent commercially available in U.S.A.

Bearing remover shaft

07746—0050100 or Equivalent commercially available in U.S.A.

NOTE

- Never reinstall the old bearings; once the bearings have been removed, they must be replaced with new ones.
- Replace wheel bearing in pairs.

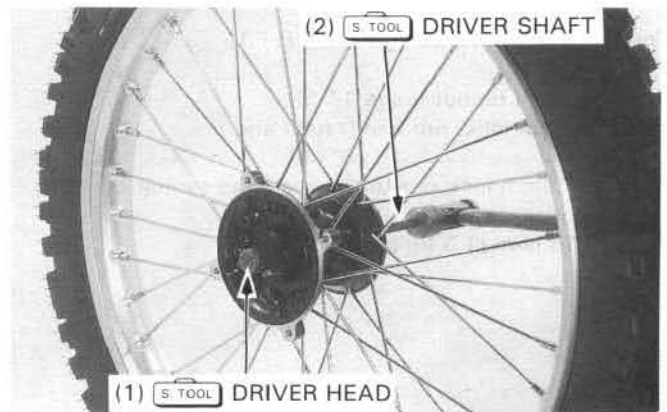
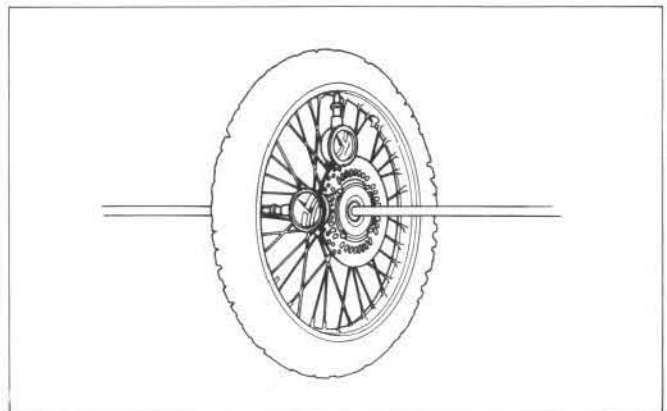
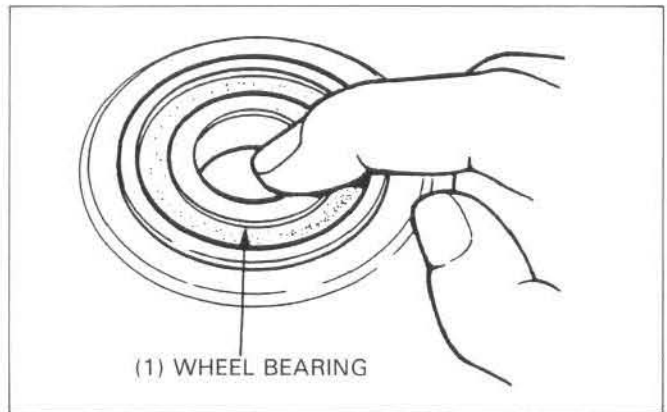
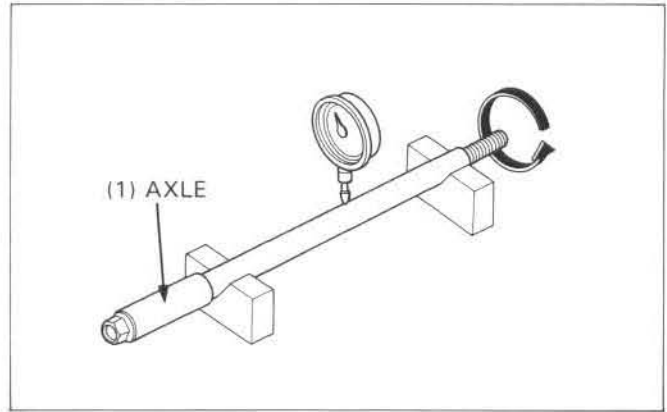

Assembly

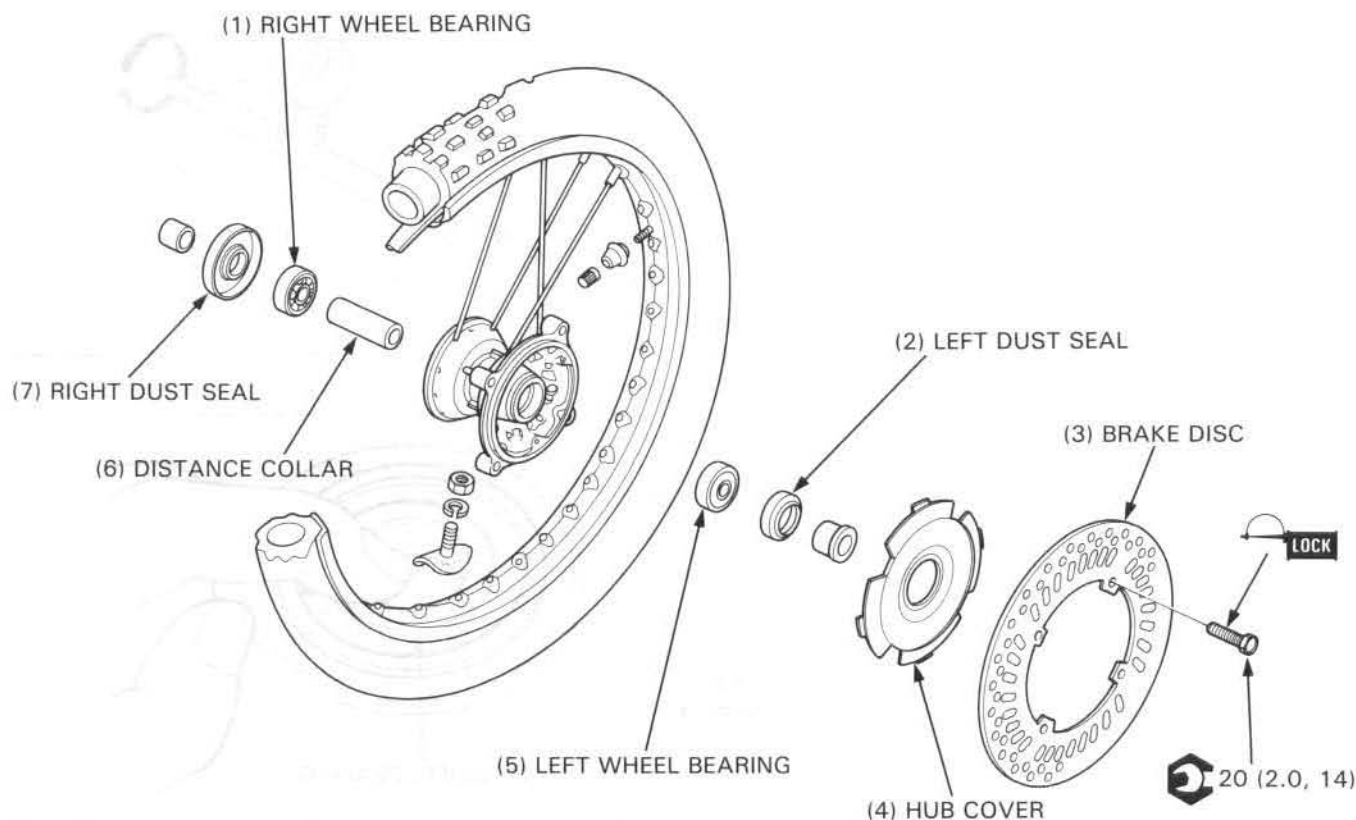

Place the rim on the work bench.

Place the hub with the disc side down and begin lacing with new spokes.

Adjust the hub position so that the distance from the hub left end surface to the side of rim is 20.00 mm (0.787 in) as shown.

Torque the spokes in 2 or 3 progressive steps.



Spoke nipple wrench

07JMA – MR60100 or Equivalent commercially available in U.S.A.

Torque: 3.8 N·m (0.38 kg-m, 2.8 ft-lb)

Check the rim runout (page 11-5).
Install the rim lock, rim band, tube and tire.

Tighten the rim lock nut to the specified torque.

Torque: 13 N·m (1.3 kg-m, 9.5 ft-lb)

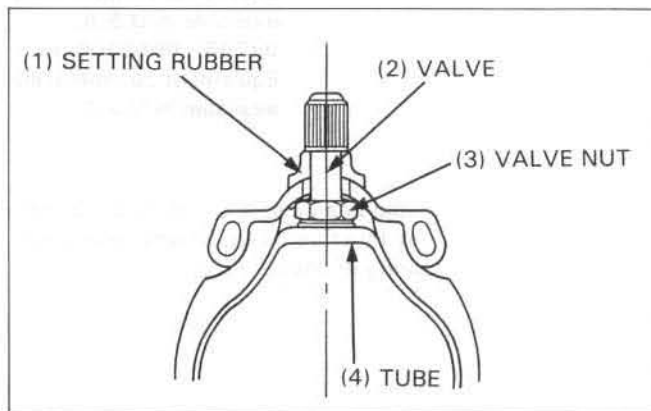
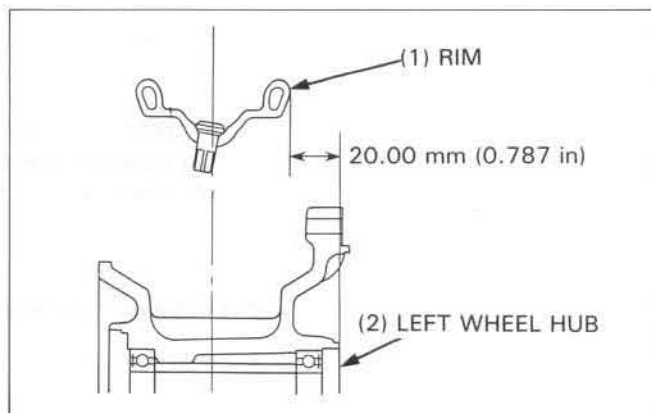

Pack all bearing cavities with grease.

Drive the right wheel bearing into the hub.

S TOOL

Driver	07749-0010000
Attachment, 32 x 35 mm	07746-0010100
Pilot, 17 mm	07746-0040400

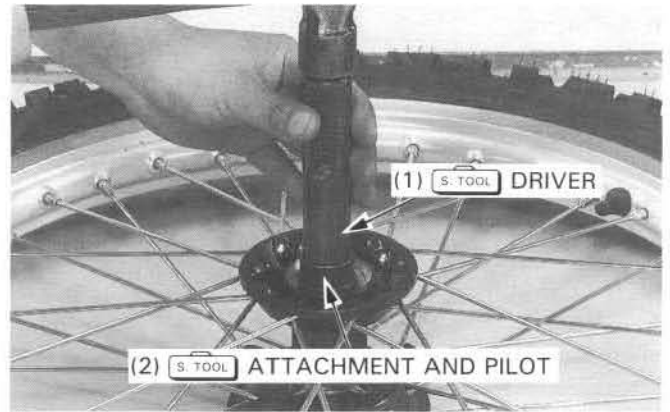

Install the distance collar.
Then drive the left wheel bearing into the hub using same tools.

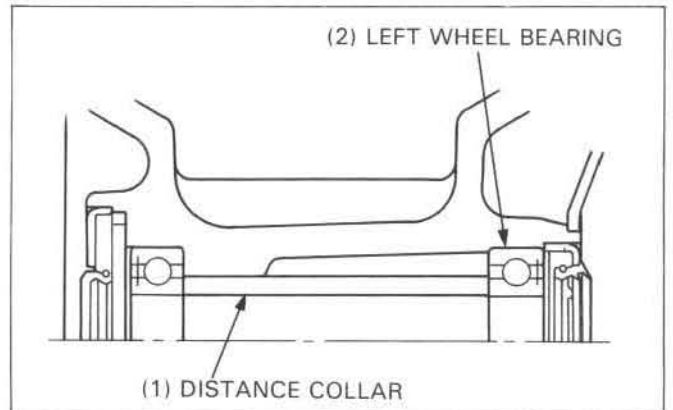

Install the hub cover onto the wheel hub.

Install the brake disc onto the wheel hub with the minimum thickness and DRIVE ⇌ markings facing out.

Clean and apply Honda Anaerobic Thread Lock or equivalent to the brake disc bolt threads.

Tighten the brake disc mounting bolts to the specified torque.

Torque: 20 N·m (2.0 kg·m, 14 ft·lb)

Pack the left dust seal lip with grease and install the left dust seal.

Install the left side collar.

Pack the right dust seal lip with grease and install the right dust seal.

Install the right side collar.

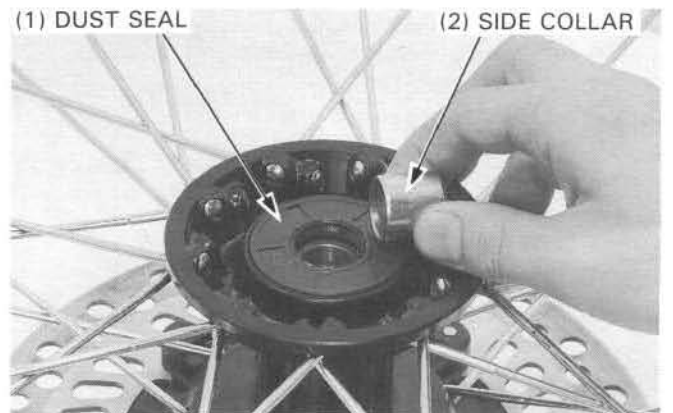
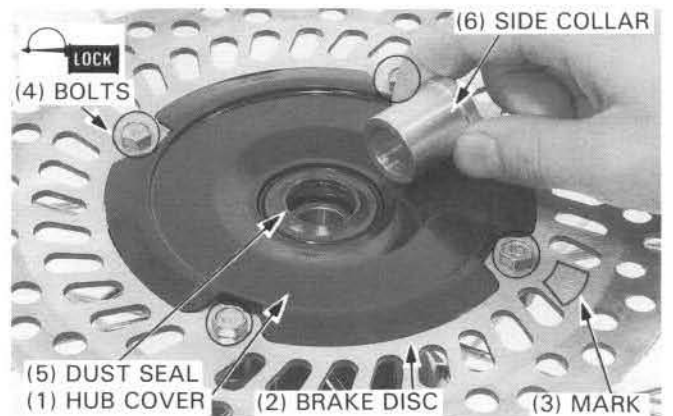

Front Wheel/Suspension/Steering

Installation

Clean the clamping surfaces of the axle shaft and axle holders.

Place the front wheel between the fork legs.

Fit the caliper over the disc, taking care not to damage the brake pads.

Apply a thin layer of grease to the axle and insert the axle from the right side.

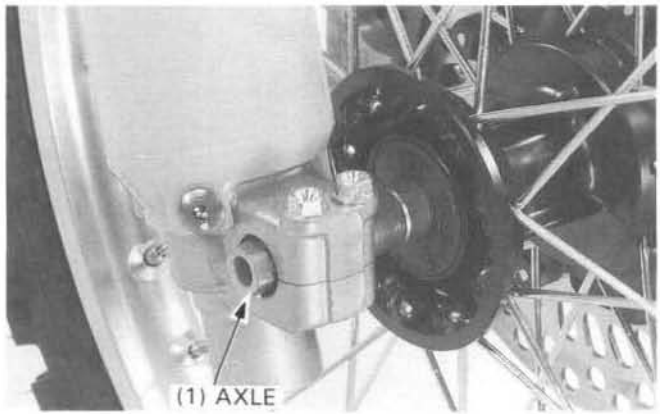

Install and tighten the axle nut to the specified torque.

Torque: 87 N·m (8.7 kg-m, 63 ft-lb)

Tighten the left axle pinch bolts.

Torque: 20 N·m (2.0 kg-m, 14 ft-lb)

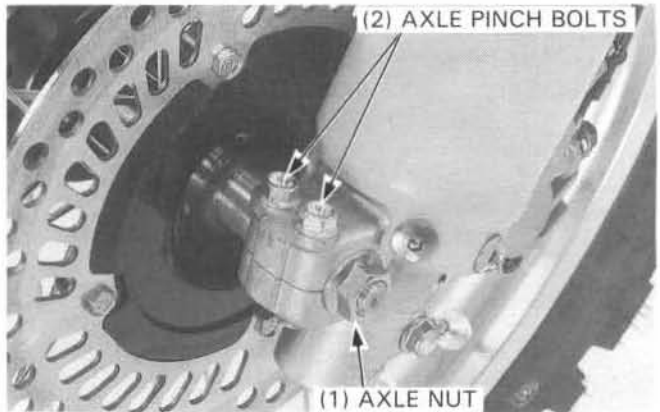

With the front brake applied, pump the front suspension up and down several times to seat the axle and check front brake operation.



Be sure the fork legs are parallel, then tighten the right axle pinch bolts to the specified torque.

Torque: 20 N·m (2.0 kg-m, 14 ft-lb)

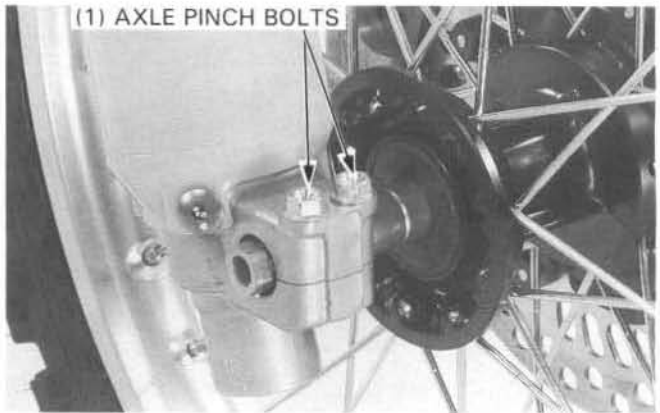

Fork

Removal

Remove the front wheel (page 11-4).

Remove the fork protector and brake caliper.

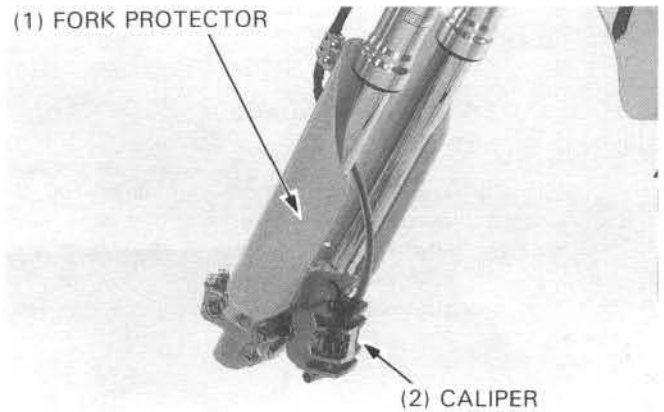

When the fork leg is to be disassembled, loosen the fork cap as follow:

Remove the handlebar assembly (page 11-19).

Loosen the fork top pinch bolts and loosen the fork cap.

CAUTION

- Do not use a crescent or adjustable wrench to loosen the fork caps; they could be damaged.

Loosen the bottom pinch bolts and pull the fork leg down and out.

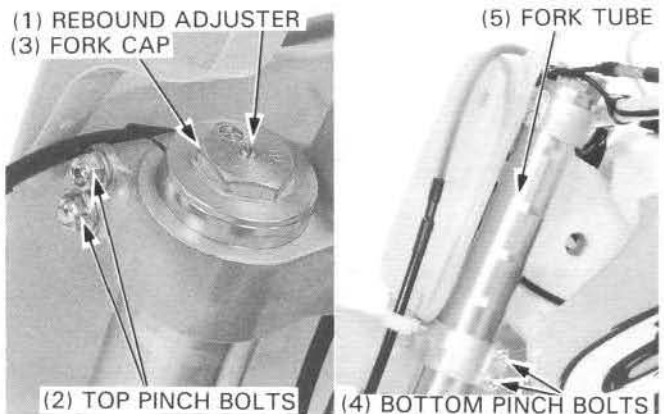

Disassembly

Clean the fork assembly, especially the sliding surface of the fork slider and the bottom of the slider around the center bolt before disassemble the fork.

CAUTION

- Be careful not to scratch the slider and not to damage the dust seal.

Install the oil level spacer on the axle holder of the slider.



Fork slider spacer

07KMZ-KZ30101

Hold the outer tube, remove the fork cap from the outer tube and slide the outer tube down onto the slider spacer.

Hold the lock nut and remove the fork cap from the damper rod.

CAUTION

- When removing the fork cap, turn the damping adjuster counterclockwise to the softest position to prevent damage to the needle (Record the number of clicks to the softest position.)

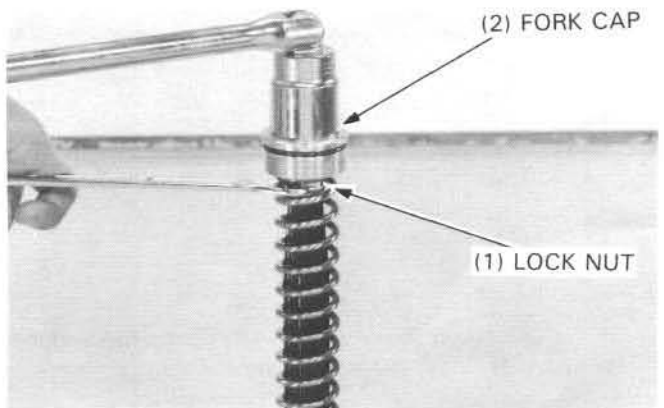
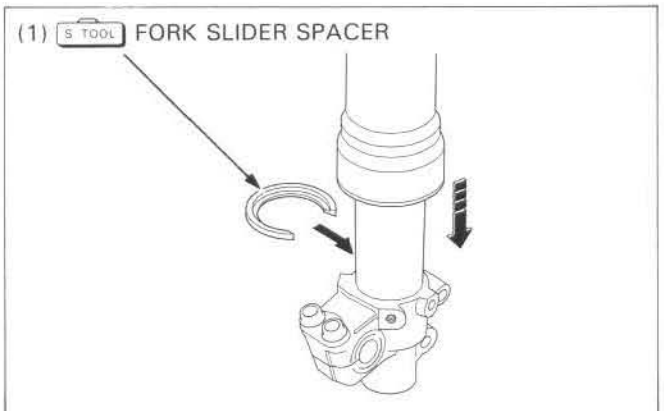

Front Wheel/Suspension/Steering

Remove the spring seat from the fork cap.

Remove the fork spring.

CAUTION

- When the fork cap is removed from the damper rod, the slider can move up and down freely on the outer tube. Always hold both the outer tube and slider with your hands after removing the fork cap, or the guide and slide bushings might be damaged and fork oil will leak from the slider.

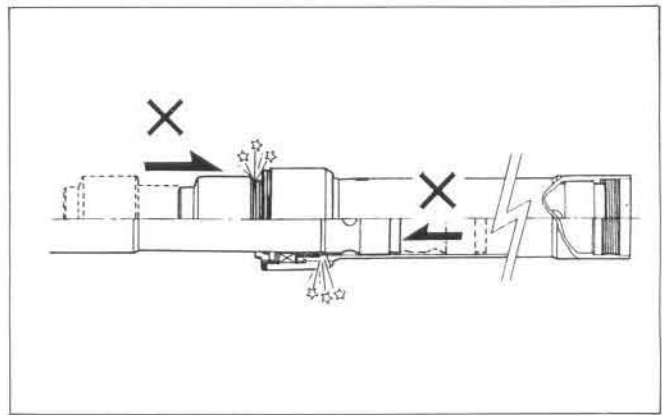

Remove the lock nut and spring guide.

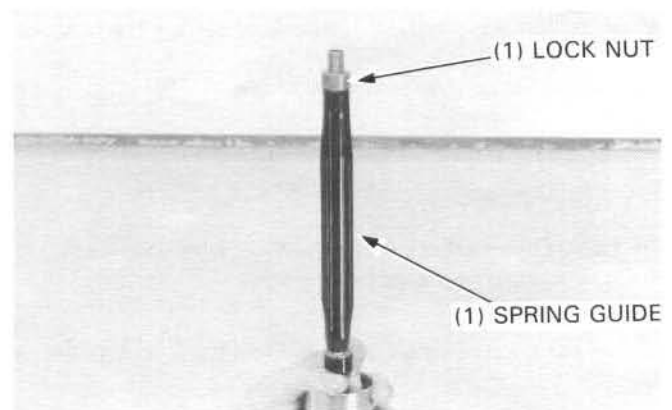

Pour out the fork oil.

Remove the distance collar, rebound needle and spring from the damper rod.

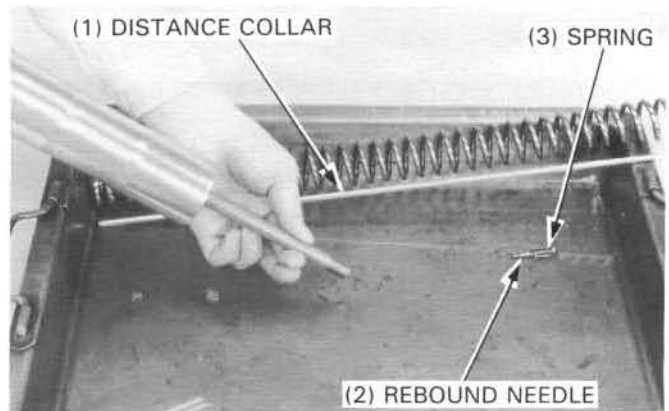

Set the lower end (axle holder) of the slider in a vise with a piece of wood or soft jaws to avoid to damage.

CAUTION

- Do not over tighten the axle holder.

Loosen and remove the center bolt and sealing washer.

NOTE

- If the center bolt turns together with the fork damper, temporarily install the fork spring and cap.

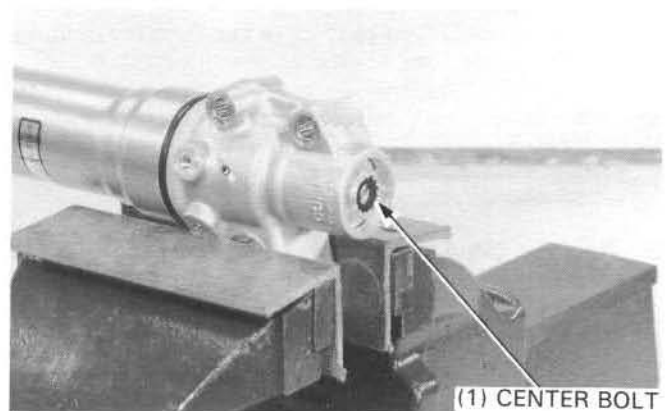

Remove the fork damper from the slider.

Empty the fork oil from the damper by pumping the damper rod 8–10 times.

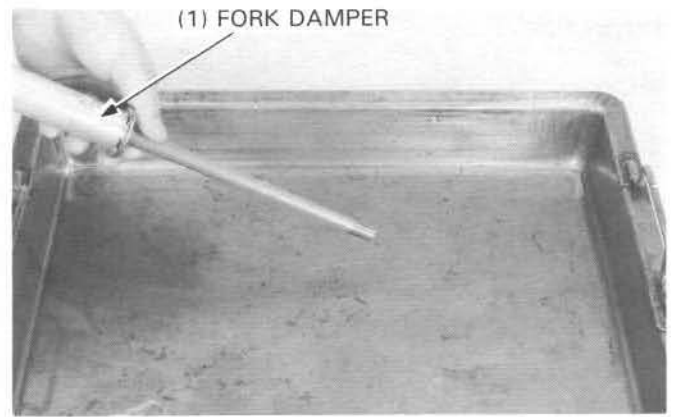

Remove the fork slider spacer from the slider.
Remove the dust seal and stop ring.

CAUTION

- Be careful not to scratch the slider.

Check that the slider moves smoothly in the outer tube.
If it does not, check the slider for bend or damage, and the bushings for wear or damage.

If the slider and bushings are normal, check the outer tube.

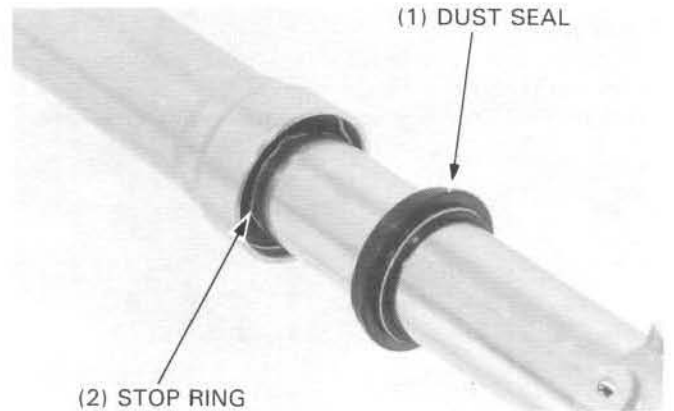

In quick successive motions, pull the slider and guide bushing out of the outer tube.

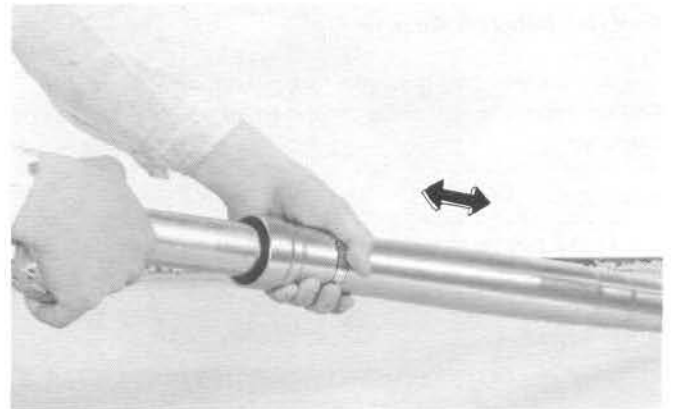

Carefully remove the slider bushing by prying the slot with a screwdriver until the bushing can be pulled off by hand.

CAUTION

- Do not damage the slider bushing, especially the sliding surface. To prevent loss of tension, do not open the bushing more than necessary.

Remove the following from the slider:

- Guide bushing
- Back-up ring
- Oil seal
- Stop ring
- Dust seal

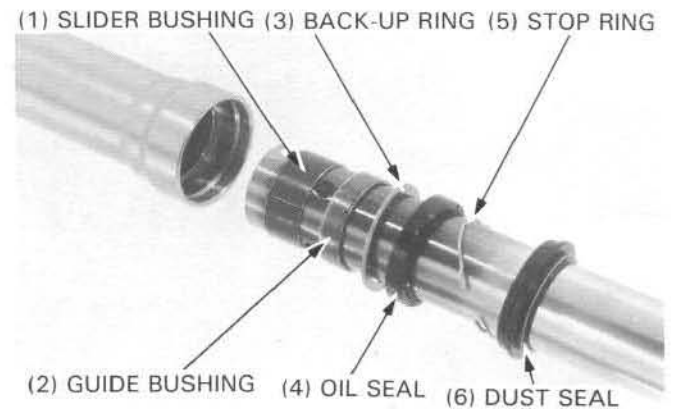

Inspection

Bushing

Check the bushings for excessive wear or scratches. If copper appears on the entire surface, replace the bushing. Replace the back-up ring if there is distortion at the points shown.

Remove any metal powder from the slider and guide bushings with a nylon brush and fork oil.

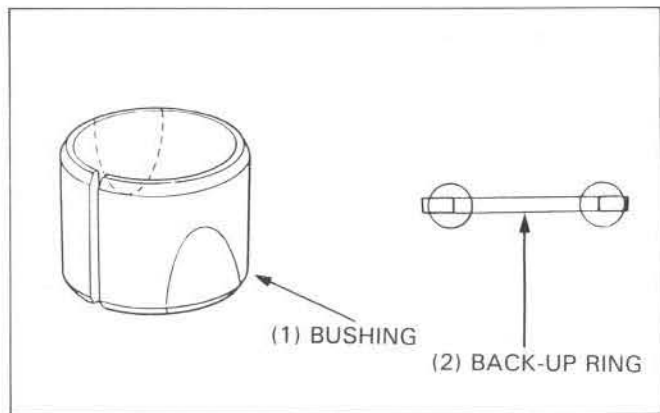

Center Bolt

Check the center bolt for damage. Replace the O-rings and sealing washer with a new one.

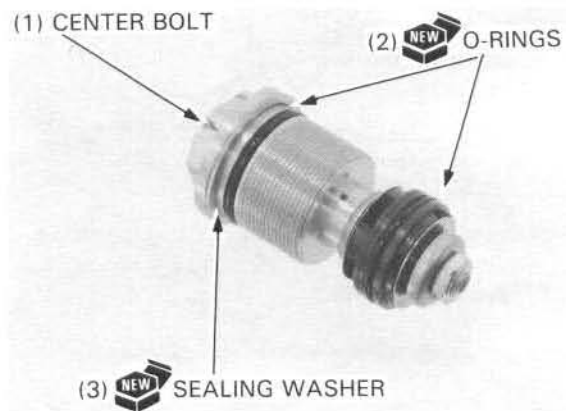

Fork Cap/Rebound Adjuster

Check that the O-ring on the fork cap is in good condition. Check that the rebound adjuster needle is not bent or damaged.

CAUTION

- If the needle is bent or damaged, the rebound damping force will be impaired.

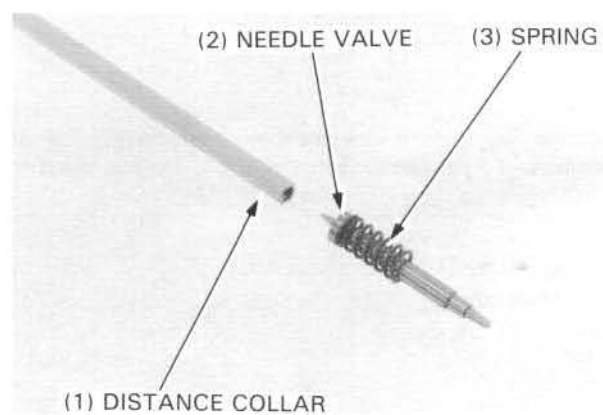
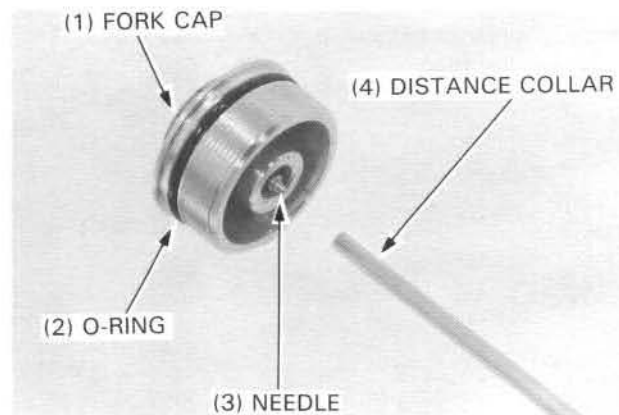

Fork Damper/Slider/Outer Tube

Check the slider for score marks, scratches and excessive or abnormal wear.
 Check the outer tube for damage or deformation.
 Check the spring guide for damage or wear.

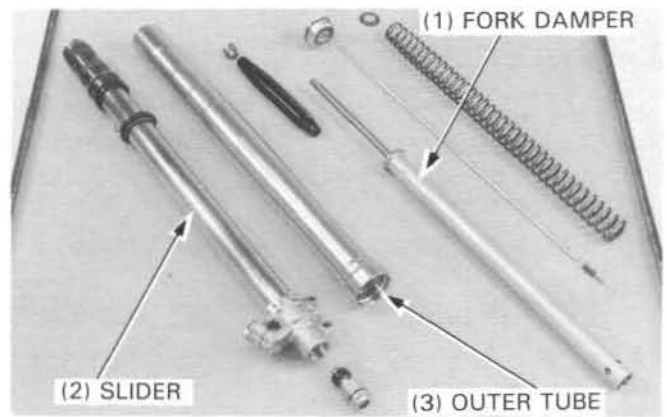

Check the damper rod for bending, wear or damage.
 Check the oil lock valve for wear or damage.

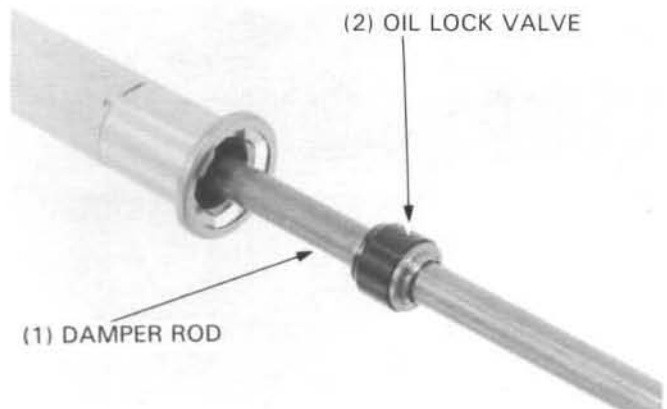

Assembly

NOTE

- Clean the disassembled parts thoroughly with non-flammable or high flash point solvent before assembly.

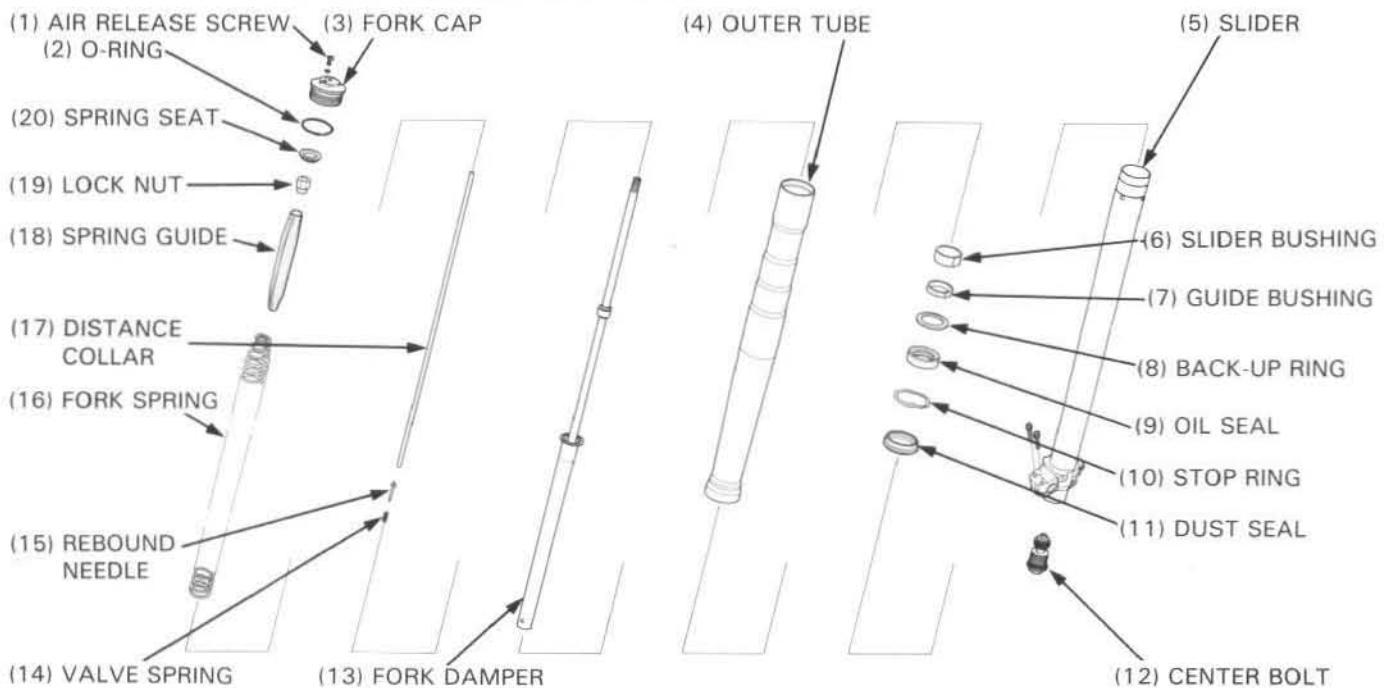

Front Wheel/Suspension/Steering

Wrap the end of the slider with tape.
Coat the new oil seal lips with fork oil.

Install the following onto the slider:

- Dust seal
- Stop ring
- Oil seal

NOTE

- Install the oil seal with its marked side facing the dust seal.

- Back-up ring
- Guide bushing
- Slider bushing

NOTE

- Remove the burrs from the bushing, taking care not to peel off its coating.

Tape or tie the dust seal and stop ring, so they won't get in the way.

Coat the slider and guide bushings with recommended fork oil and install the slider into the outer tube.

Drive the guide bushing with the back-up ring into the outer tube first, using the special tool.
Drive the oil seal into outer tube using the special tool.

 S-TOOL

Oil seal driver

07KMD—KZ30100

Oil seal driver attachment

07NMD—KZ30100

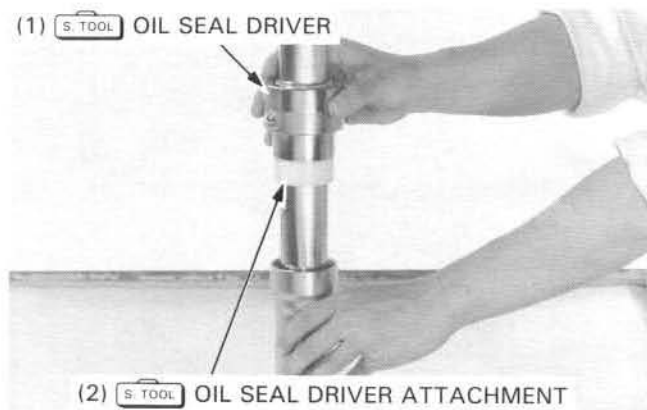
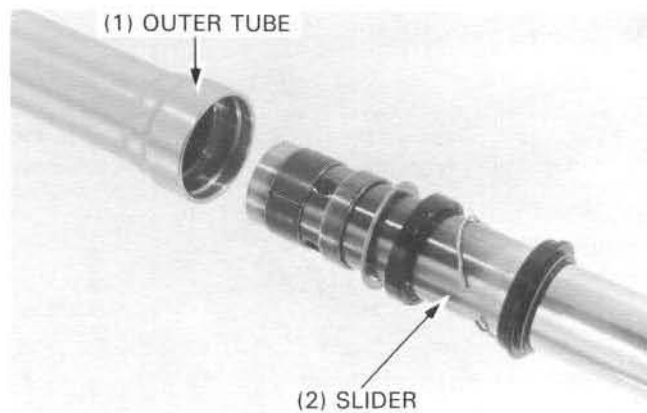
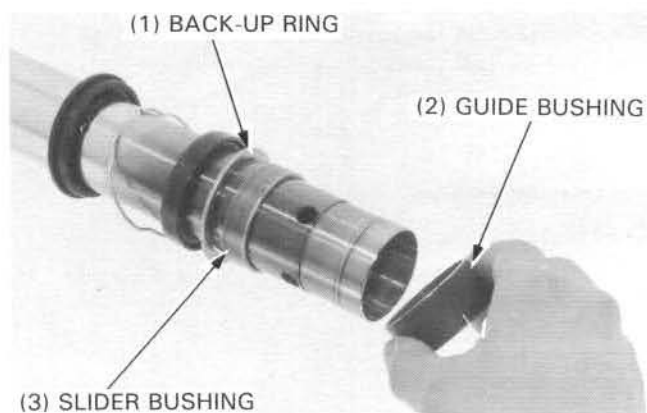
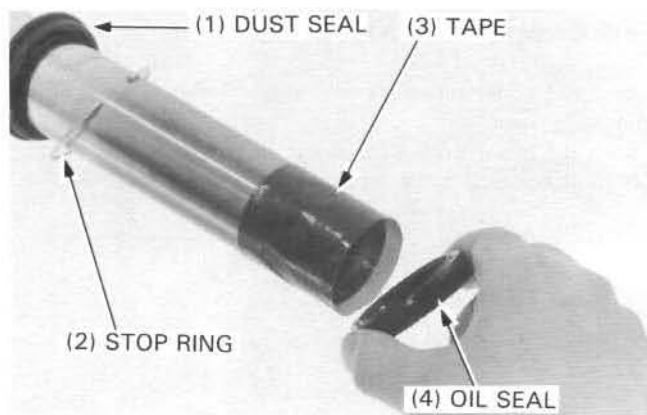

Remove the tape or tie and install the stop ring and dust seal.

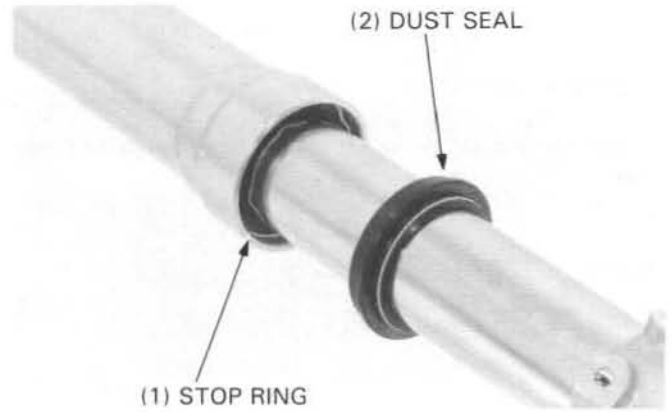

CAUTION

- The outer tube can move up and down freely on the slider. Always hold the slider and fork tube with your hands, or the guide and slider bushings and dust seal might be damaged.

To avoid damaging the dust seal, install the special tool and lower the fork tube gently onto the tool.



Fork Slider spacer

07KMZ-KZ30101

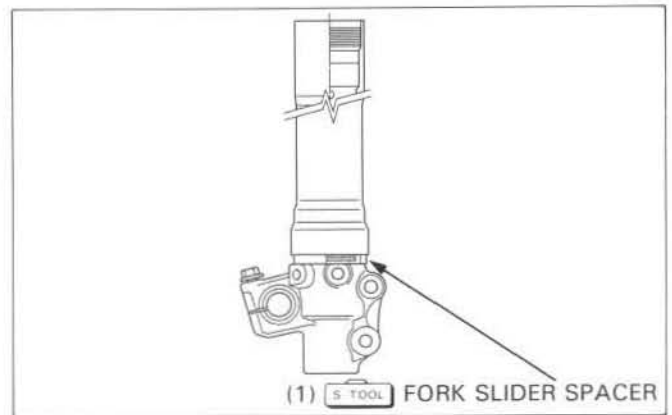

Install the fork damper into the slider.

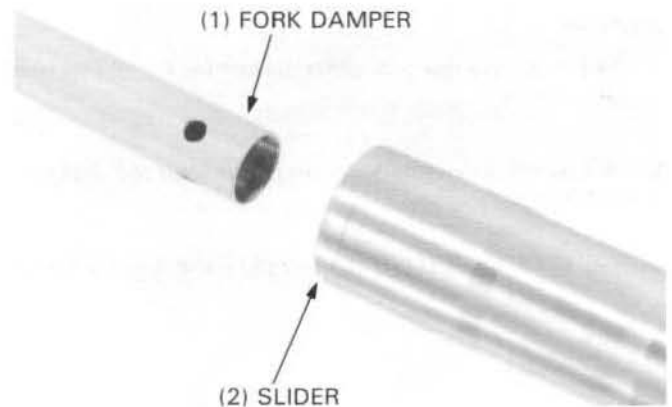

Hold the axle holder in a vise protected with a piece of wood or soft jaws.

CAUTION

- Do not overtighten the axle holder.

Install the center bolt with a new sealing washer and tighten the bolt to the specified torque.

Torque 80 N·m (8.0 kg-m, 58 ft-lb)

NOTE

- If the center bolt turns together with the fork damper, temporarily install the fork spring and cap.

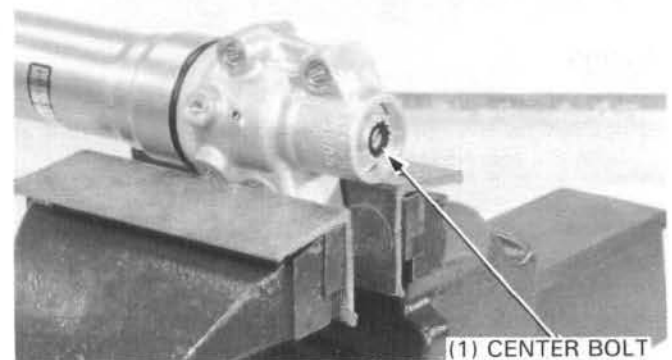

Front Wheel/Suspension/Steering

Wipe off any excess oil from the spring guide.

Install the guide with the oil holes facing up.

Temporarily install the lock nut with the flange side facing down.

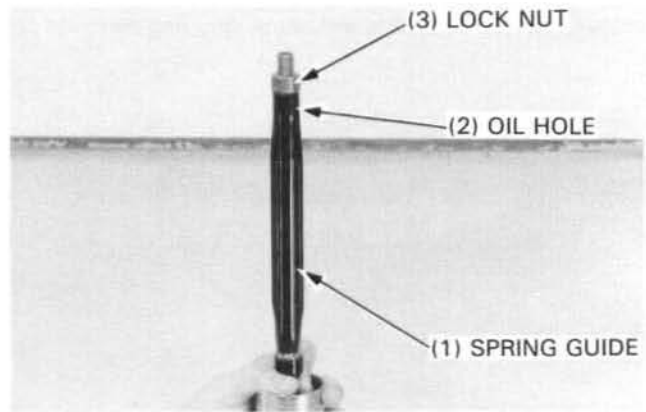

Install the spring, rebound needle and distance collar.

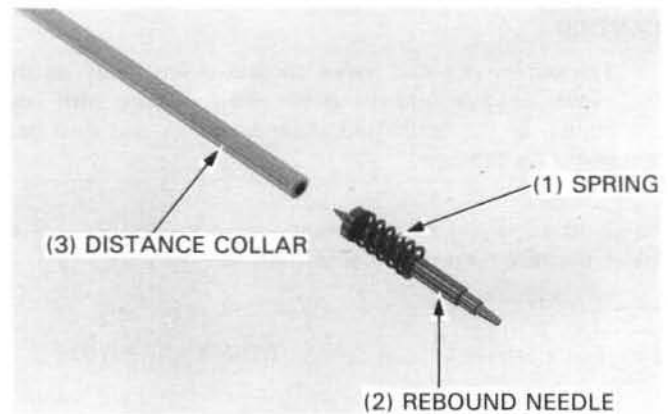

CAUTION

- You must use the fork slider spacer for correct oil level adjustment.

Pour the recommended fork oil into the damper rod until the oil flow out the damper rod end.

Pour half the amount of recommended fork oil into the fork leg.

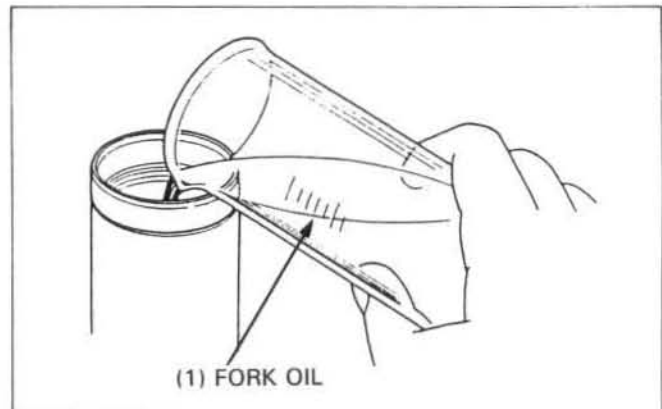

Bleed the air as follows:

1. Extend the fork. Cover the top of the outer tube with your hand and compress the fork slowly.

CAUTION

- The fork oil will spill out of the oil hole in the slider. Do not pull up the outer tube more than 250 mm (9.8 in) from the axle holder to extend the fork.

2. With the damper rod fully pushed in, add the recommended fork oil into the rod until a little flows out of the rod end.
3. Pump the outer tube and rod slowly 8–10 times.
4. Add additional oil up to the specified capacity and repeat step 3.

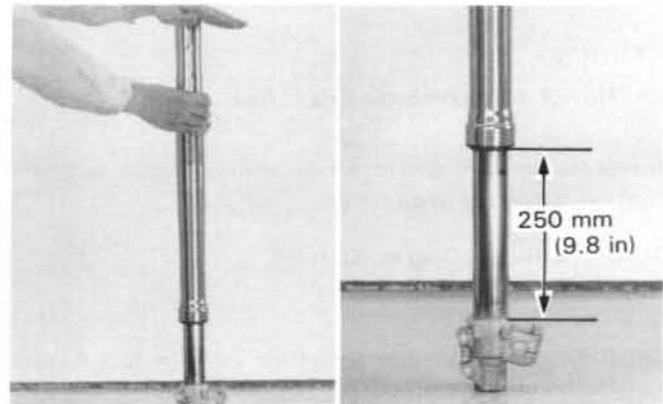

Recommended Oil: Pro Honda Suspension Fluid SS-7M or equivalent

Standard oil level: 106 mm (4.2 in)

Standard capacity: 571 cc (19.31 oz)

NOTE

- Be sure the oil level is the same in both fork legs.
- Support the fork leg vertically whenever measuring the oil level.

Maximum level capacity	92 mm (3.62 in) 588 cc (20.53 oz)	Slightly stiffer as it nears full compression.
Minimum level capacity	123 mm (4.84 in) 553 cc (19.41 oz)	Slightly softer as it nears full compression.

For the detail of the oil level adjustment, refer to Owner's Manual.

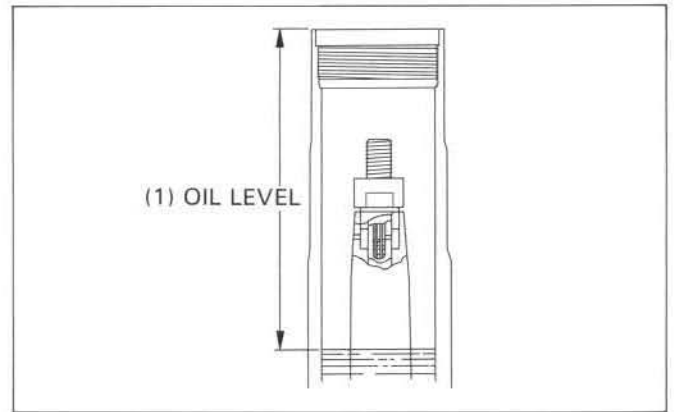

Attach a 60 mm (2 feet) length of mechanic's wire to the lock nut on the damper rod.

Wipe off any excess oil from fork spring, then install it over wire into the slider with tapered side facing up.

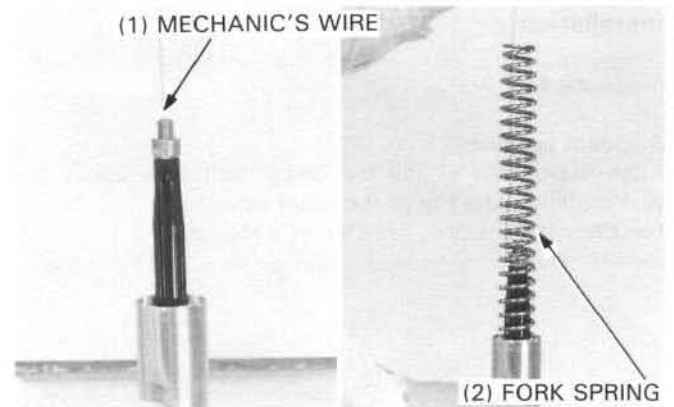

Pull the mechanic's wire up and hold the damper rod at the oil lock valve.
Remove the mechanic's wire from the rod.

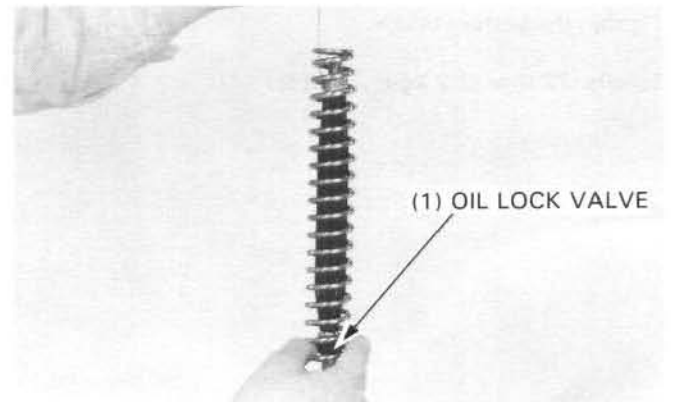

Front Wheel/Suspension/Steering

Turn the lock nut by hand until it bottoms on the damper rod.
Install the spring seat onto the fork spring.

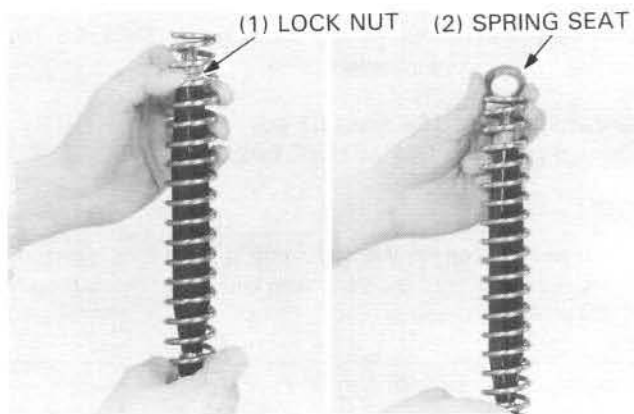

Check that the fork cap O-ring is in good condition.

Screw the fork cap on the damper rod.
Hold the lock nut and tighten the fork cap to the specified torque.

Torque: 22 N·m (2.2 kg-m, 15 ft-lb)

Temporarily install the fork cap in the outer tube.

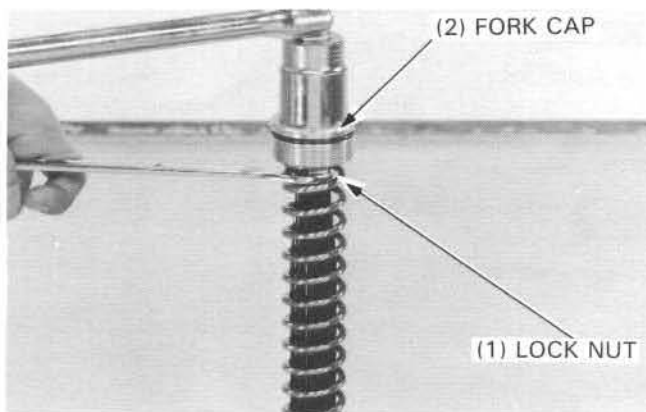

Installation

Install the fork leg

Standard position:

Align the groove of the top bridge with the groove 9 mm (0.4 in) below the top of the outer tube.
For alternate position, see Owner's Manual.

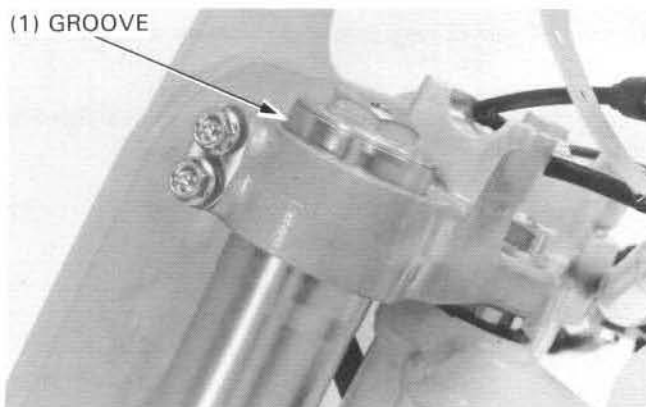

Tighten the bottom bridge.

Torque: 22 N·m (2.2 kg-m, 16 ft-lb)

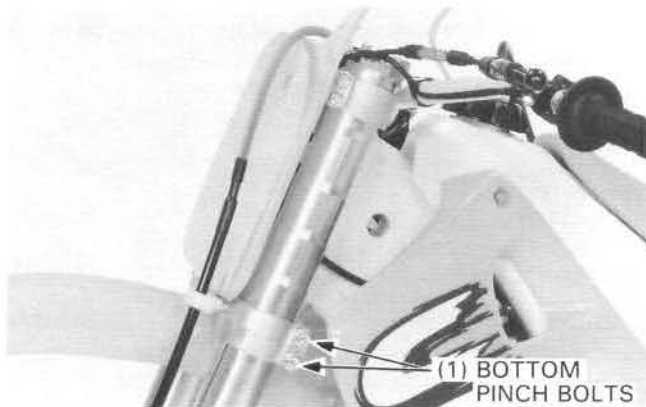

Tighten the fork cap to the specified torque.

Torque: 35 N·m (3.5 kg-m, 25 ft-lb)

Tighten the top bridge pinch bolt to the specified torque.

Torque: 22 N·m (2.2 kg-m, 16 ft-lb)

CAUTION

- Over tightening the pinch bolts can deform the fork tubes. Deformed the fork tubes must be replace.

Return the rebound adjuster to its original position as noted during removal.

Clean and apply a Honda Anaerobic Thread Lock or equivalent to the fork protector bolt.

Install the fork protector and tighten the bolt to the specified torque.

Torque: 13 N·m (1.3 kg-m, 9.5 ft-lb)

Clean and apply a Honda Anaerobic Thread Lock or equivalent to the caliper bracket bolt.

Install the caliper and tighten the bolt to the specified torque.

Torque: 31 N·m (3.1 kg-m, 22 ft-lb)

Install the handlebar assembly (page 11-21).

Install the front wheel (page 11-8).

Handlebar

Removal

Disconnect the engine stop switch wire connectors.

Unhook the holding tab of the number plate.

Remove the wire bands securing the engine stop button wire and remove the engine stop button.

Disconnect the clutch cable and remove the clutch lever bracket.

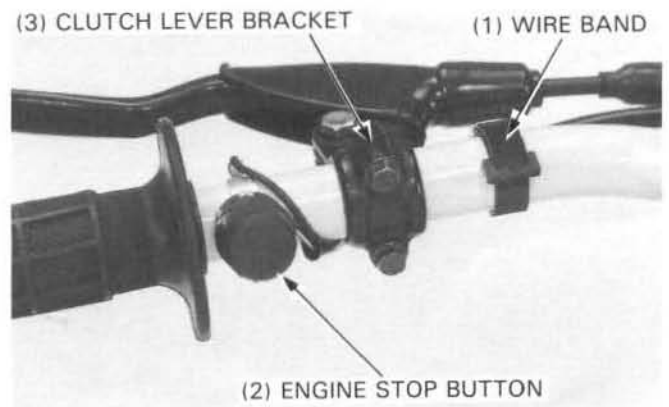
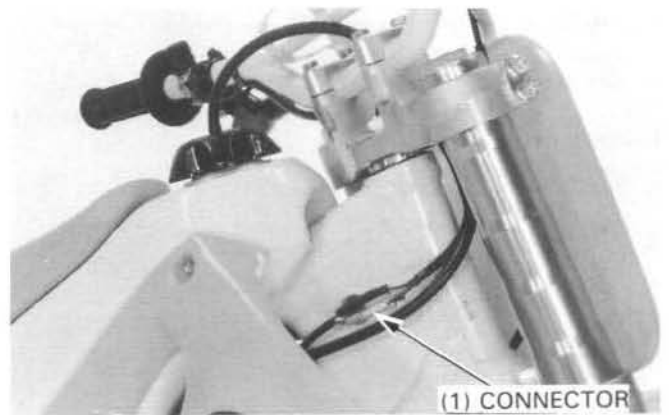
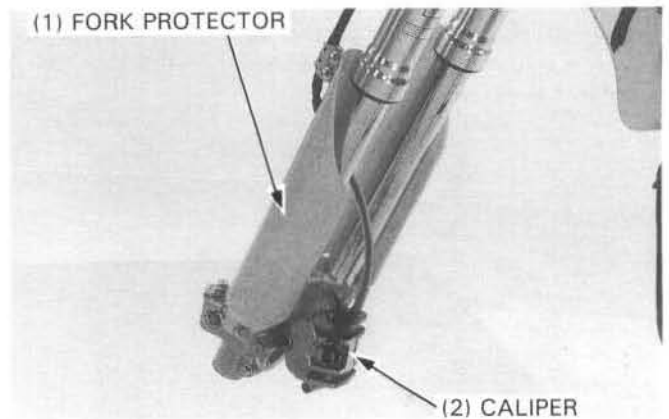
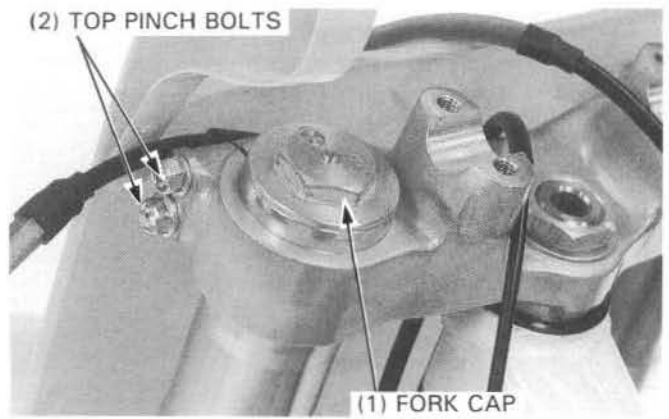

Front Wheel/Suspension/Steering

Remove the front brake master cylinder, master cylinder holder, keeping it upright to prevent air from entering the hydraulic system.

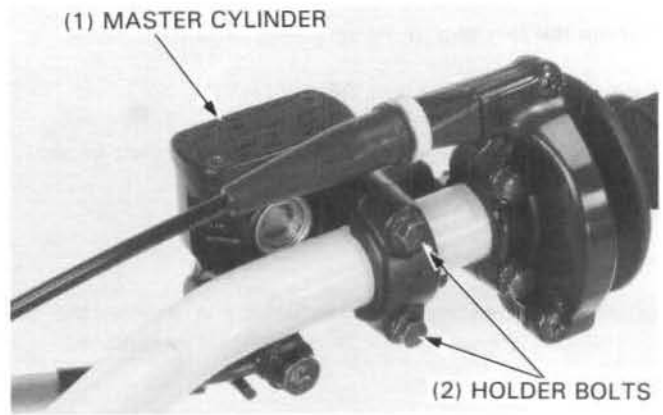

Remove the throttle housing cover by removing the screws. Slide the rubber protector off and loosen the lock nut and adjuster.

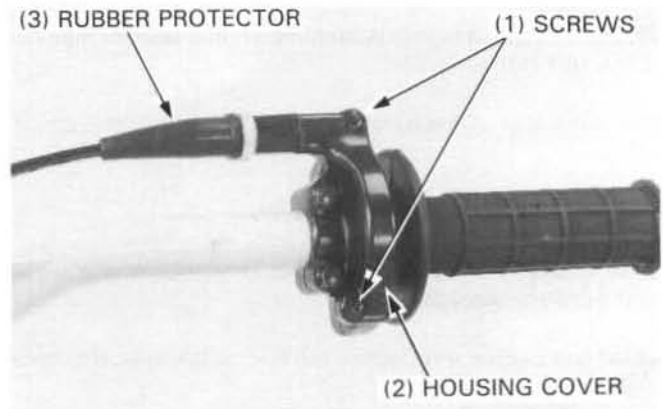

Disconnect the throttle cable from the throttle grip by removing the lock nut and adjuster.

Loosen the throttle housing mounting bolts and remove the throttle grip from the handlebar.

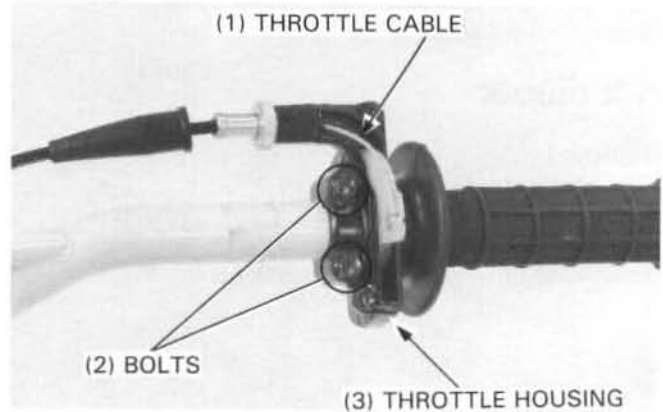

Remove the handlebar holder bolts, upper holders and handlebar.

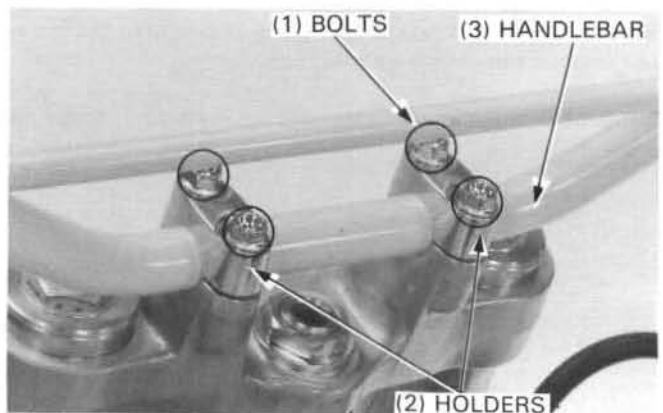

Installation

Install the handlebar.
Align the punch mark on the handlebar with the top of the lower holder.
Place the upper holder on the handlebar with the punch marks facing forward.

Install and tighten the forward handlebar holder bolts first, then tighten the rear bolts.

Torque: 22 N·m (2.2 kg-m, 16 ft-lb)

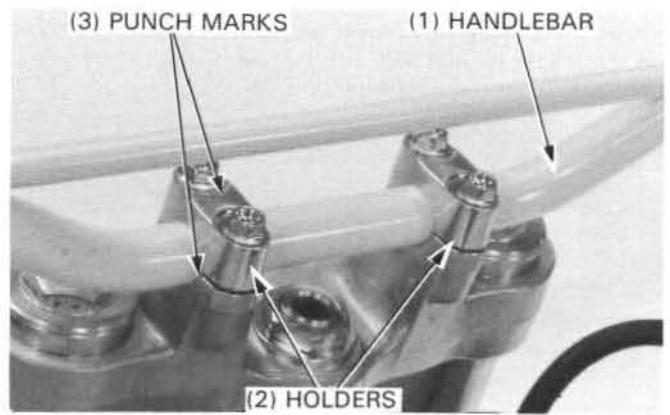

Apply thin coat of oil to the sliding surfaces of the throttle grip and throttle housing.
Connect the throttle cable end to the throttle pipe.

Install the throttle housing aligning the slit of the housing with the punch mark on the handlebar.
Tighten the upper bolt first, then the lower bolt.

Torque: 10 N·m (1.0 kg-m, 7 ft-lb)

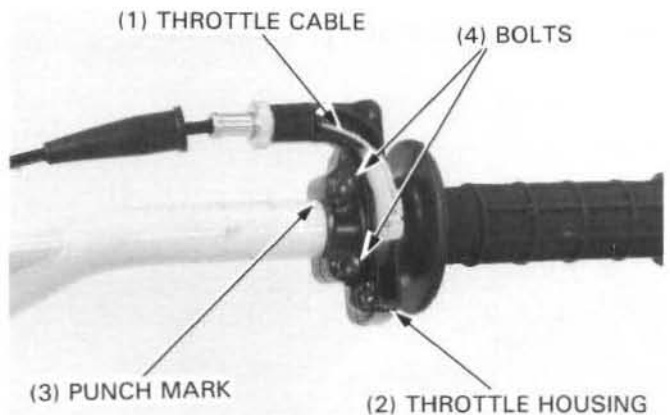

Install the throttle housing cover and tighten the screws securely.

Torque: 1.5 N·m (0.15 kg-m, 1.1 ft-lb)

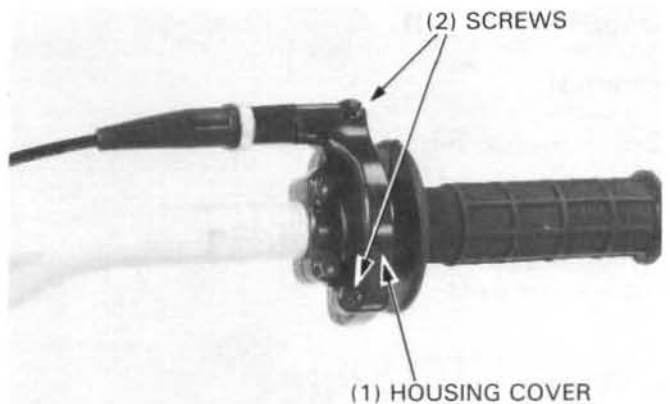

Set the brake master cylinder on the handlebar.
Install the master cylinder holder with the "UP" mark up and align the end of the holder with the punch mark on the handlebar.

Tighten the master cylinder holder bolts.

NOTE

- Tighten the upper bolt first, then the lower bolt.

Torque: 10 N·m (1.0 kg-m, 7 ft-lb)

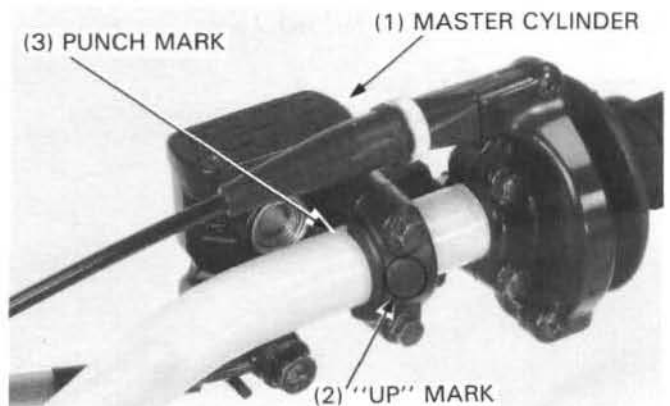

Front Wheel/Suspension/Steering

Install the clutch lever bracket and holder with the punch mark on the holder up and aligning the end of the holder with the punch mark on the handlebar.

NOTE

- Tighten the upper bolt first, then the lower bolt.

Connect the clutch cable.

Route the engine stop button wire.
Install the engine stop button on the handlebar.
Attach the engine stop button wires to the handlebar using the wire bands.

Route the fuel cap breather tube.
Hook the number plate tab onto the handlebar.

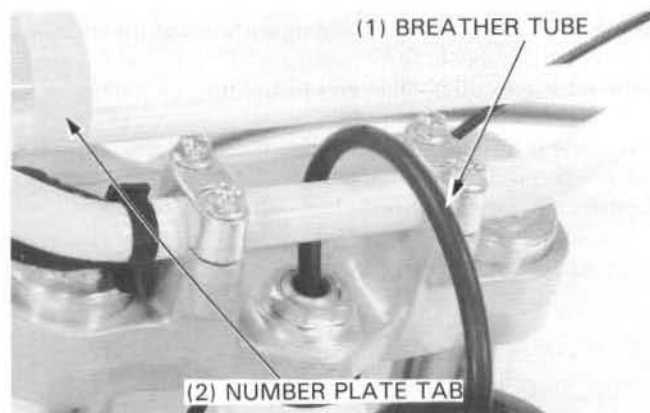
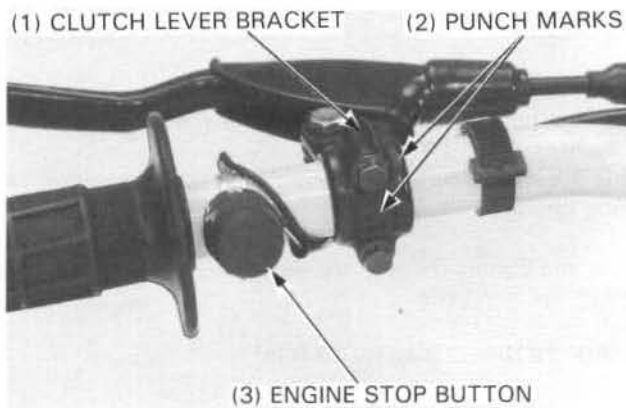

Steering Stem

Removal

- Remove the following:
- Handlebar (page 11-19)
 - Front wheel (page 11-4)
 - Front fender mounting bolts and collar
 - Front fender
 - Brake hose guide

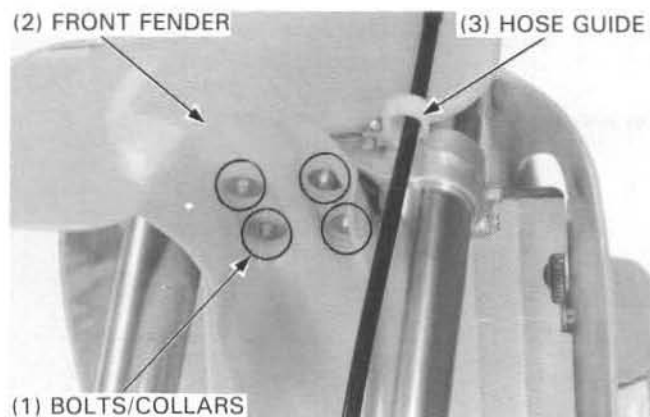

Remove the steering stem nut and washer.

Remove the fork legs (page 11-9).
Remove the fork top bridge.

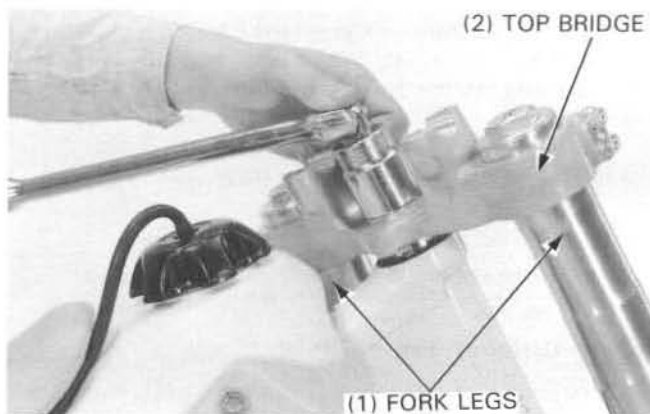

Remove the steering head adjusting nut.



Steering stem socket

07716-0020500 or
Equivalent commercially
available in U.S.A.



Remove the dust seal, upper taper roller bearing and steering stem from the head pipe.

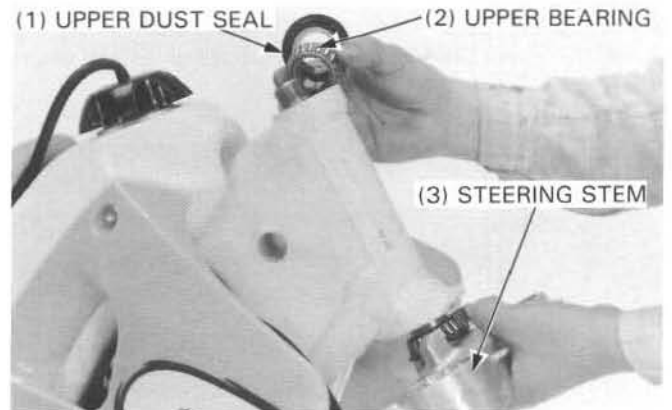

Bearing Replacement

Remove the lower taper roller bearing and dust seal from the steering stem.

NOTE

- Avoid damaging the steering stem threads, temporarily install the stem nut.

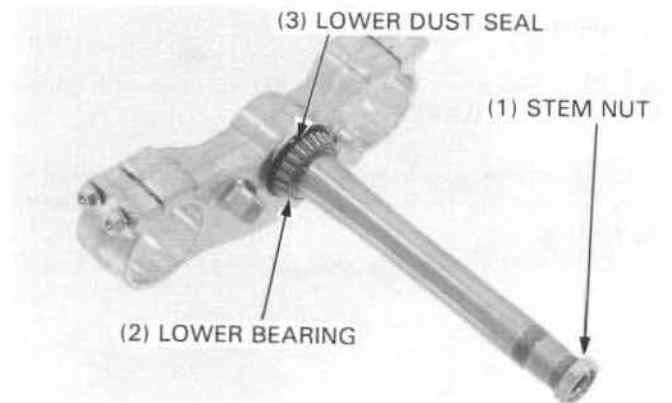

Remove the upper and lower bearing outer races from the head pipe.



Ball race remover

07948-4630100

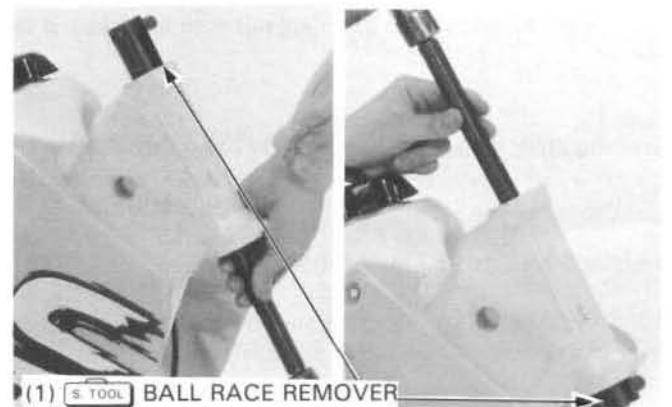

Installation

Install the new bearing races.

NOTE

- If the motorcycle has been involved in an accident, examine the area around the steering head for cracks.



Driver 07749-0010000
Attachment, 52 x 55 mm 07746-0010400

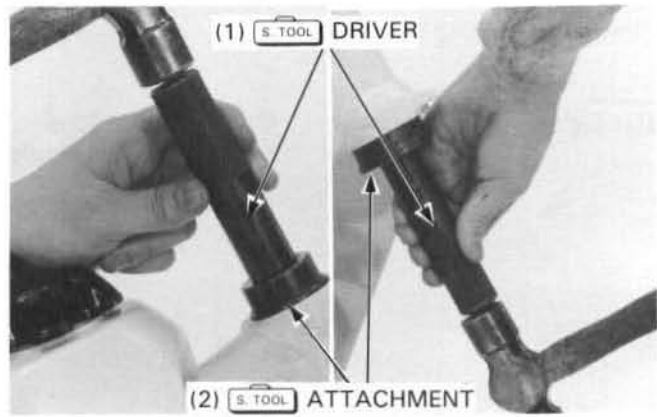

Install the dust seal.
Install the lower bearing using a hydraulic press and driver.



Steering stem driver 07946-MB00000

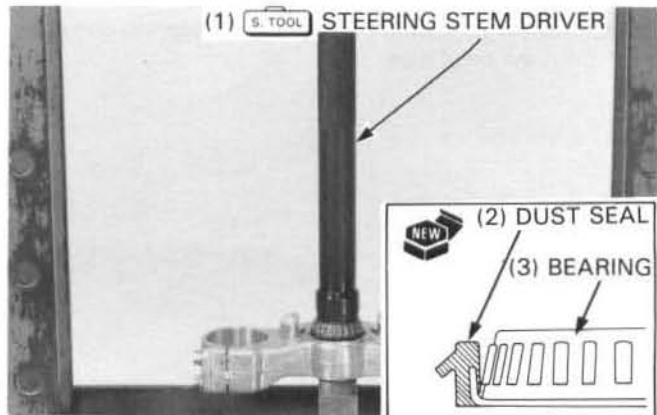

Installation

Pack the upper and lower taper roller bearings with grease.
Apply grease to the all bearing area.

Install the upper taper roller bearing in the steering head pipe.
Slide the steering stem through the steering head pipe from the bottom.
Install the dust seal washer and steering head adjusting nut.

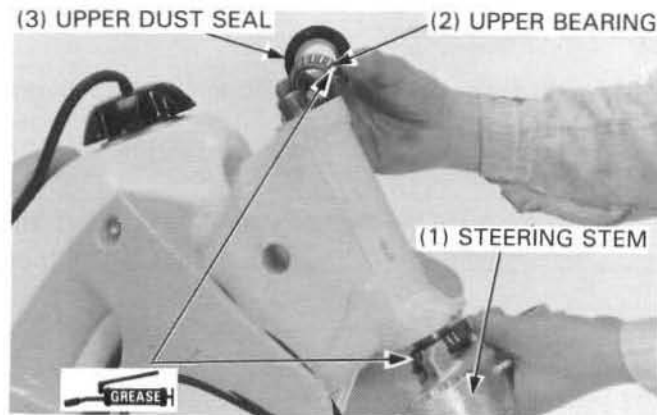

Tighten the steering head adjusting nut with the steering stem socket.



Steering stem socket 07716-0020500 or
Equivalent commercially
available in U.S.A.

Torque: 2 N·m (0.2 kg-m, 1.4 ft-lb)

Turn the steering stem lock-to lock 5 times to seat the bearings and tighten the adjusting nut again.

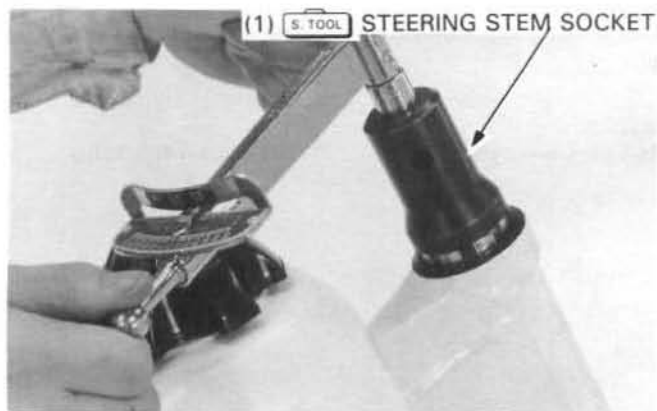

Install the following:

- Fork bridge
- Fork legs (page 11-18)
- Washer onto the top bridge

Install and tighten the stem nut to the specified torque.

Torque: 118 N·m (11.8 kg-m, 85 ft-lb)

Recheck the steering stem adjustment before installing the removed parts.

Install the removed parts in the reverse order of removal.

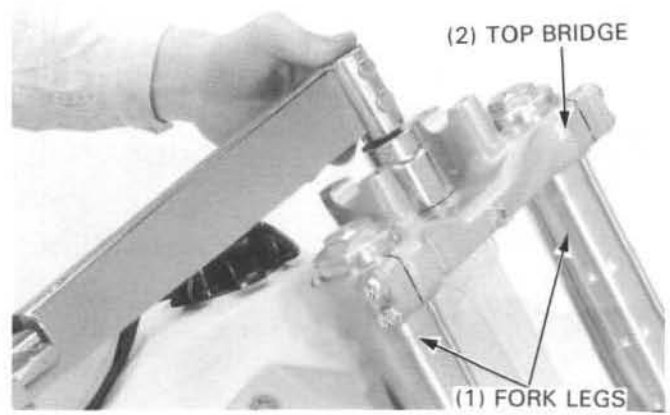

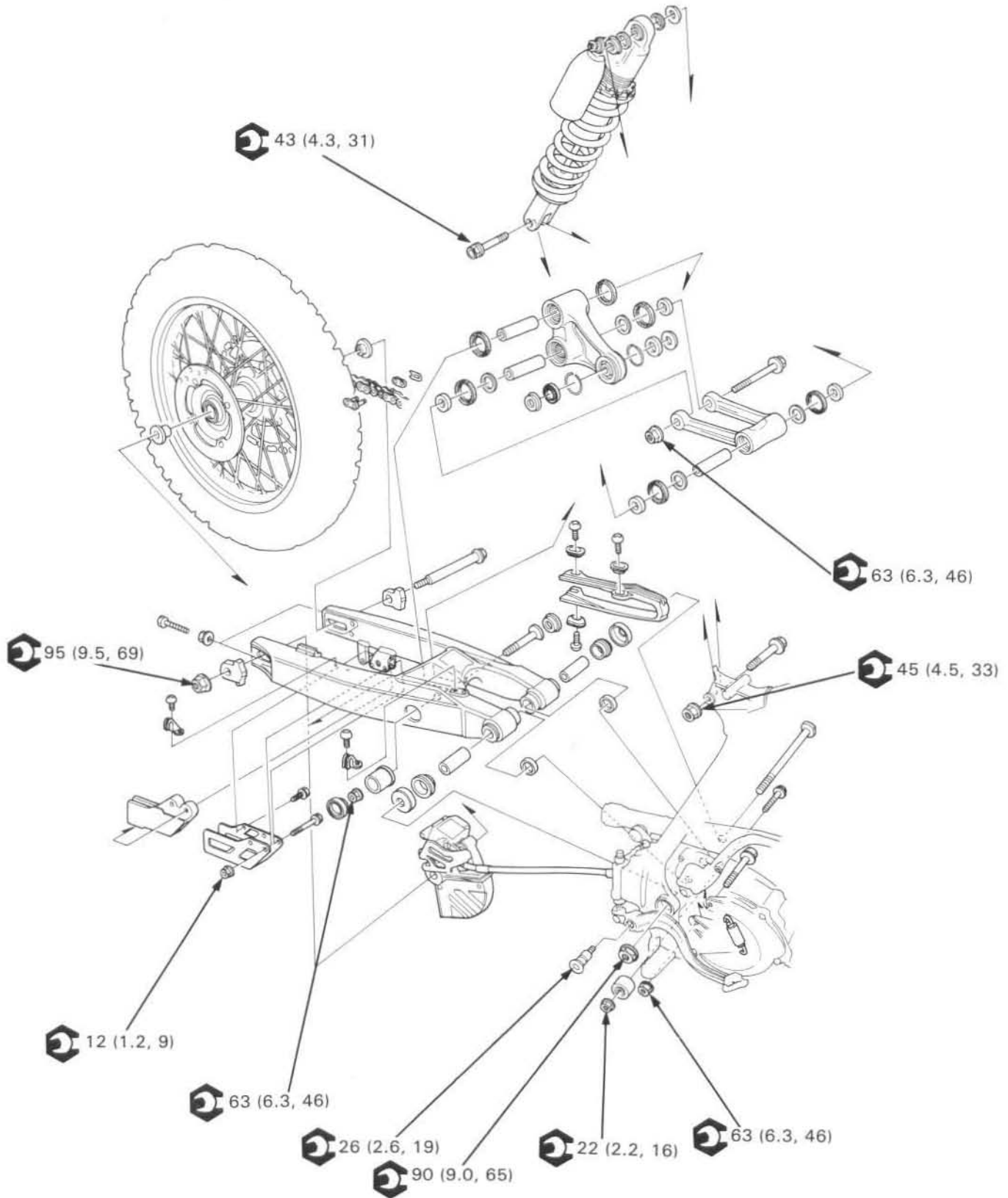

12. Rear Wheel/Suspension

Service Information	12-1	Shock Absorber	12-8
Troubleshooting	12-2	Shock Linkage	12-23
Rear Wheel	12-3	Swingarm	12-26

Service Information

General

▲ WARNING

- Use only nitrogen to pressurize the shock absorber. The use of an unstable gas can cause a fire or explosion resulting in serious injury.
- The shock absorber contains nitrogen under high pressure. Do not allow fire or heat near the shock absorber.
- Before disposal of the shock absorber, release the nitrogen by pressing the valve core. Then remove the valve from the shock absorber.

Brake dust may contain asbestos fibers.

Never use an air hose or dry brush to clean brake assemblies.

▲ WARNING

- Inhaled asbestos fibers have been found to cause respiratory disease and cancer.

Keep grease off of brake pads and disc.

▲ WARNING

- A contaminated brake disc or pads reduces stopping power. Discard contaminated pads and clean a contaminated disc with Pro Honda Contact/Brake Cleaner or an equivalent high quality brake degreasing agent.

- Use genuine Honda bolts for the rear suspension linkage and shock absorber pivot and mounting; ordinary bolts lack adequate strength for these applications. Also take note of the installation direction of these bolts since they must be installed correctly.
- For optimum suspension performance and linkage component service life, the swingarm and shock linkage pivot bearings (along with related seals and bushings) should be disassembled, cleaned, inspected for wear and lubricated with multi-purpose grease NLGI No. 2 (molybdenum disulfide additive) each 3 races or 7.5 hours of running.
- Optional rear wheel sprockets, drive chain, shock springs and spring preload pin spanners are available. Refer to General Information, Section 1.
- A box or work stand is required to support the motorcycle.
- Refer to the section 13 for brake system information.

Specifications

Unit mm (in)

Item	Standard	Service Limit
Axle runout	—	0.20 (0.008)
Wheel rim runout	(Radial)	2.0 (0.08)
	(Axial)	2.0 (0.08)
Shock absorber spring free length	265 (10.4)	262 (10.3)
Damper gas pressure	981 kPa (10.0 kg/cm ² , 142 psi)	—
Shock absorber spring installed length	(Standard)	255.0 (10.04)
	(Adjustable range: Max.)	260.5 (10.26)
	(Adjustable range: Min.)	244.5 (9.63)
Recommended shock absorber oil	Pro Honda Suspension Fluid SS-7 or equivalent	—
Shock oil capacity	290 cc (9.81 US oz, 10.35 Imp oz)	—

Rear Wheel/Suspension

Torque Values

Rear axle nut	95 N•m (9.5 kg-m, 69 ft-lb)
Final driven sprocket	30 N•m (3.0 kg-m, 24 ft-lb)
Shock absorber mounting (Upper)	45 N• (4.5 kg-m, 33 ft-lb)
(Lower)	43 N•m (4.3 kg-m, 31 ft-lb)
Shock absorber damper rod end nut	27 N• (2.7 kg-m, 20 ft-lb)
Shock absorber damping adjuster	20 N•m (2.0 kg-m, 14 ft-lb)
Shock absorber spring lock nut	90 N•m (9.0 kg-m, 65 ft-lb)
Chain tensioner roller bolt	22 N•m (2.2 kg-m, 16 ft-lb)
Shock arm bolt (Swingarm side)	63 N•m (6.3 kg-m, 46 ft-lb)
(Shock link side)	63 N•m (6.3 kg-m, 46 ft-lb)
Shock link bolt (frame side)	63 N•m (6.3 kg-m, 46 ft-lb)
Swingarm pivot bolt	90 N•m (9.0 kg-m, 65 ft-lb)
Chain guide mounting bolt	12 N•m (1.2 kg-m, 9 ft-lb)

Tools

Special

Spoke nipple wrench	07JMA—MR60100 or equivalent commercially available in U.S.A.
Needle bearing driver	07946—KA50000
Sleeve collar	07974—KA30201
Spherical bearing driver	07HMF—KS60100
Slider guide, 14 mm	07974—KA40001
Bearing remover set	07936—3710001
—Remover handle	07936—3710100
—Bearing remover set	07936—3710600
—Remover weight	07741—0010201
Attachment, 28 x 30 mm	07946—1870100
Needle bearing driver	07946—MJ00100
Driver head	07946—KM40701

Common

Driver	07749—0010000
Attachment, 42 x 47 mm	07746—0010300
Remover head, 20 mm	07746—0050600
Remover shaft	07746—0050100
Pilot, 20 mm	07746—0040500
Retainer wrench B	07710—0010200
Retainer wrench body	07710—0010401
Attachment, 24 x 26 mm	07746—0010700
Attachment, 32 x 35 mm	07746—0010100
Pilot, 22 mm	07746—0041000

Optional

Pin spanner A	89201-KS6-810 x 2
---------------	-------------------

Troubleshooting

Soft Suspension

- Weak spring
- Oil leakage from damper unit

Hard Suspension

- Incorrectly mounted suspension components
- Bent swingarm pivot
- Damaged swingarm pivot bushings

Steers To One Side Or Does Not Track Straight

- Bent rear axle
- Axle alignment/chain adjustment not equal on both sides

Rear Wheel Wobbling

- Bent rim
- Worn rear wheel bearings
- Faulty tire

Rear Wheel

Removal

Raise the rear wheel off the ground with a box or workstand under the engine.

Loosen the lock nuts and drive chain adjusting bolts.
Remove the axle nut and axle.

Push the wheel forward to allow removal of the drive chain from the driven sprocket and remove the rear wheel.

CAUTION

- When removing the rear wheel, be careful not to damage the brake pads with the disc.

NOTE

- Do not depress the brake pedal after the rear wheel is removed. The caliper piston will move out and make reassembly difficult.

Disassembly

Remove the following:

- Left side collar
- Driven sprocket
- Dust seal
- Right side collar
- Brake disc
- Dust seal

If necessary, remove the tire, tube, rim band and the rim lock.

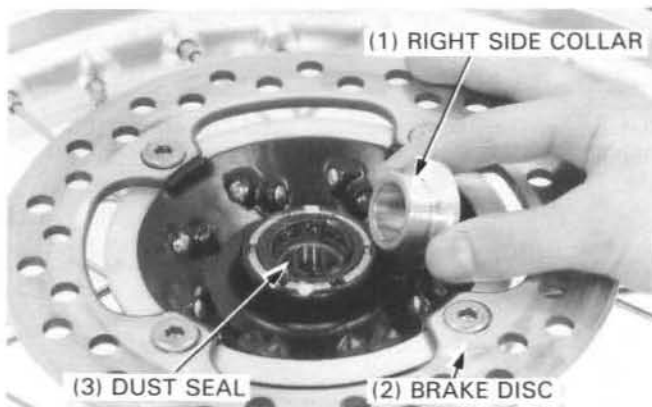
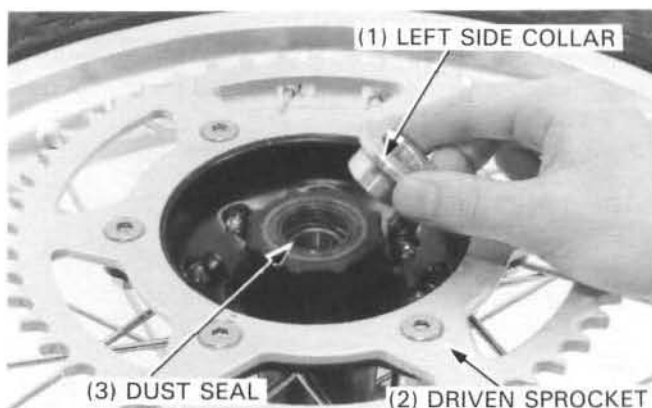
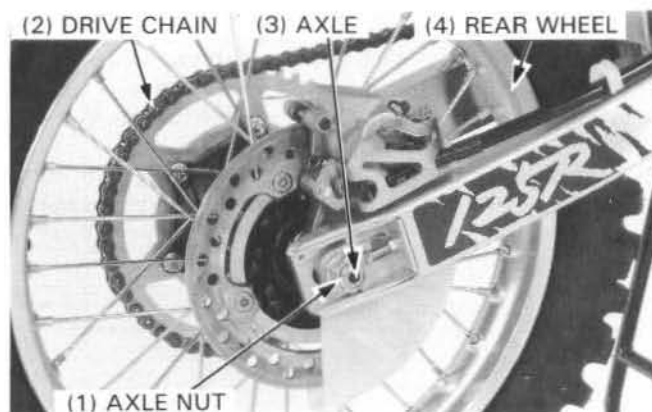

Inspection

Axle

Set the axle in V blocks and measure the runout. Actual runout is 1/2 the total indicator reading.

Service Limit: 0.20 mm (0.008 in)

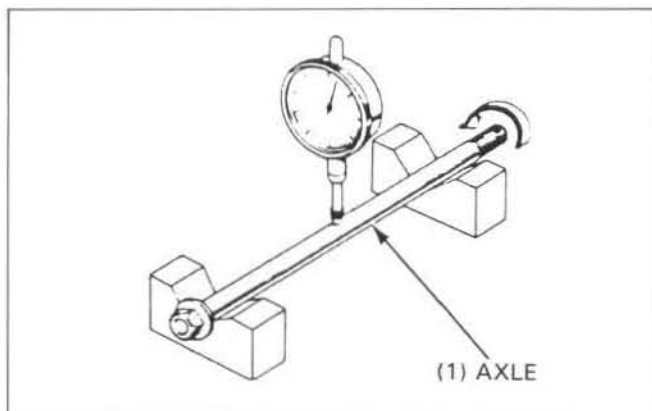

Rear Wheel/Suspension

Wheel Bearings

Turn the inner race of each bearing with your finger. The bearings should turn smoothly and quietly. Also check that the bearing outer races fit tightly in the hub.

Remove and discard the bearings if the races do not turn smoothly, quietly, or if outer races fit loosely in the hub.

NOTE

- Replace wheel bearings in pairs.

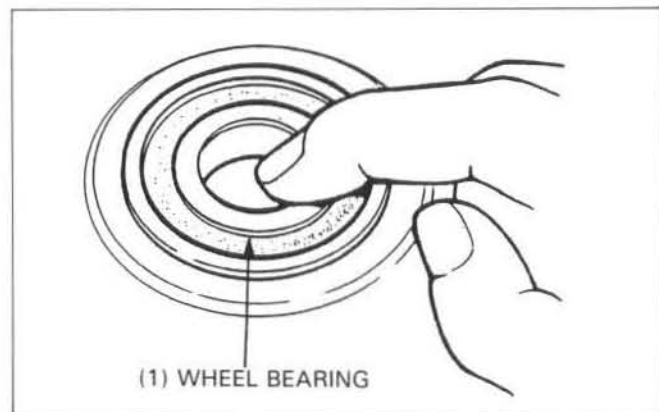

Wheel Rim

Check the rim runout by placing the wheel on a turning stand. Then rotate the wheel by hand, and read the runout using a dial indicator.

Actual runout is 1/2 the total indicator reading.

Service Limit: Radial: 2.0 mm (0.08 in)

Axial: 2.0 mm (0.08 in)

Check the spokes and tighten any that are loose.

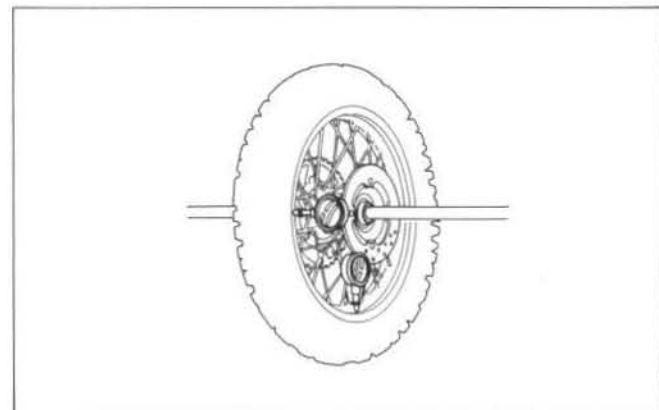

S. TOOL

Spoke nipple wrench

07JMA-MR60100 or
Equivalent commercially
available in U.S.A.

Remove the bearing retainer using the special tools.

S. TOOL

Retainer wrench B

07710-0010200

Retainer wrench body

07710-0010401

(1) S. TOOL RETAINER WRENCH B

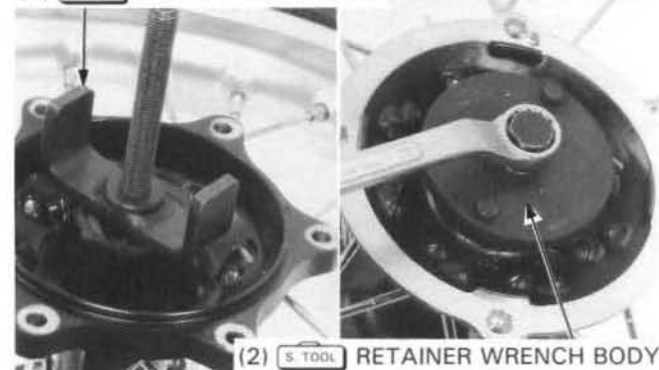

(2) S. TOOL RETAINER WRENCH BODY

Remove the wheel bearings and distance collar using the special tools.

S. TOOL

Bearing remover head, 20 mm

07746-0050600

Bearing remover shaft

07746-0050100

NOTE

- Never reinstall the old bearings; once the bearings have been removed, they must be replaced with new ones.
- Replace wheel bearing in pairs.



(1) S. TOOL BEARING REMOVER SHAFT

(2) S. TOOL REMOVER HEAD

Assembly

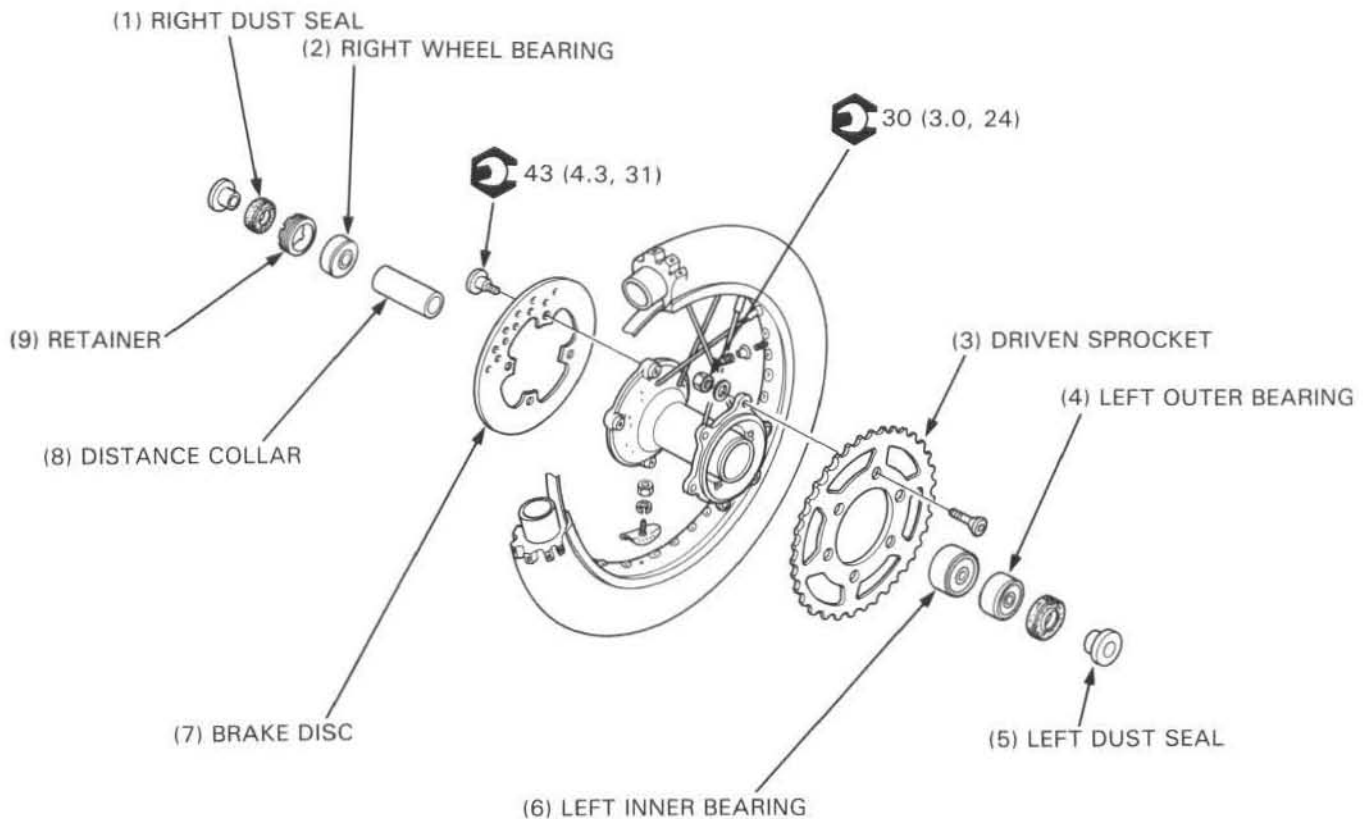

Place the rim on the work bench, with its directional arrow going counterclockwise.

Place the hub in the center of rim, and begin lacing with new spokes.

Adjust the hub position so that the distance from the hub left end surface to the side of rim is 47.0 mm (1.85 in) as shown. Torque the spokes in 2 or 3 progressive steps.



Spoke nipple wrench

07JMA – MR60100 or Equivalent commercially available in U.S.A.

Torque: 3.8 N·m (0.38 kg-m, 2.8 ft-lb)

Check the wheel runout.

Install the rim lock, rim band, tube and tire.

Tighten the rim lock nut to the specified torque.

Torque: 13 N·m (1.3 kg-m, 9.5 ft-lb)

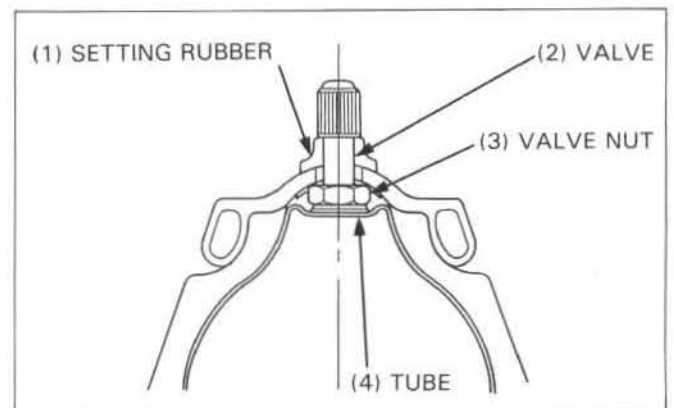
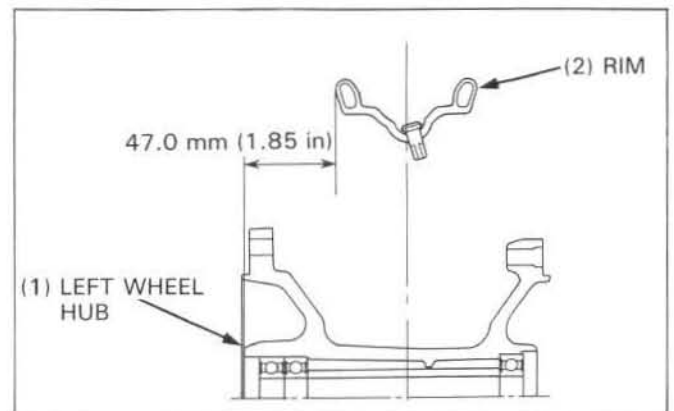

Rear Wheel/Suspension

Drive the right wheel bearing into the hub using special tools.

S TOOL

Driver	07749-0010000
Attachment, 42 x 47 mm	07746-0010300
Pilot, 20 mm	07746-0040500

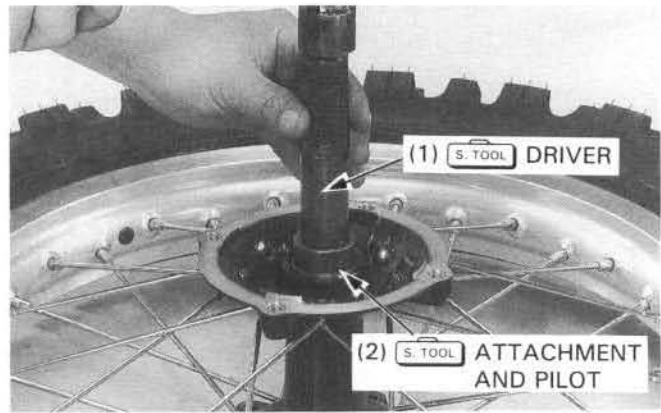

Install the distance collar.
Then drive the left wheel bearings into the hub using same tools.

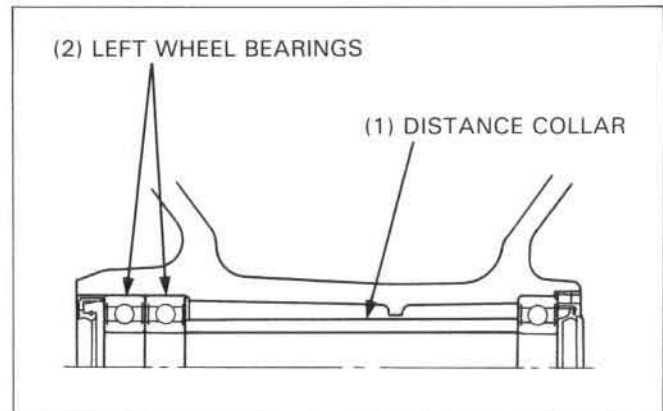

Apply grease to the bearing retainer and install it into the hub using the special tools.

S TOOL

Retainer wrench B	07710-0010200
Retainer wrench body	07710-0010401

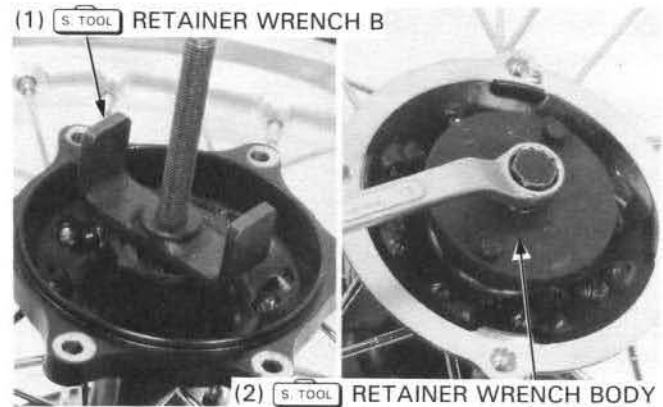

Peen the edge of the retainer as shown.

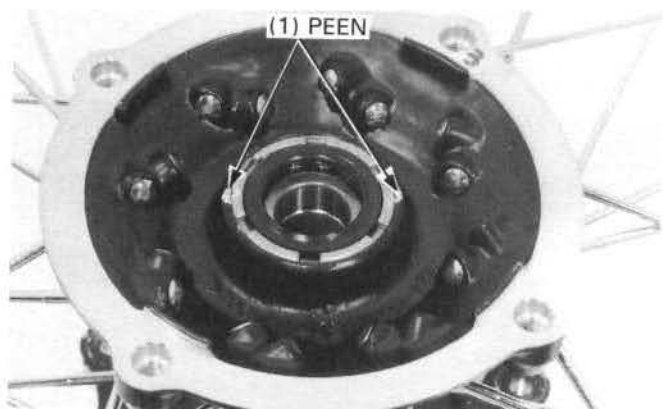

Install the brake disc onto the wheel hub with the minimum thickness and DRIVE ⇨ markings facing out. Clean the brake disc bolts and apply Honda Anaerobic Thread Lock or equivalent to the threads. Tighten the brake disc mounting bolts to the specified torque.

Torque: 43 N·m (4.3 kg-m, 31 ft-lb)

Pack the dust seal lip with grease and install the right dust seal. Install the right side collar.

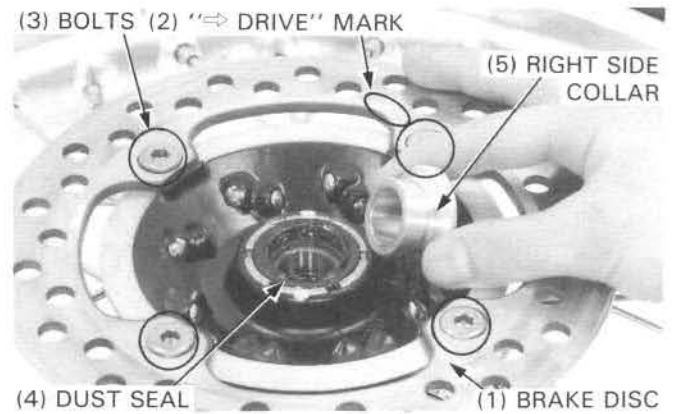

Install the driven sprocket onto the wheel hub. Install the bolts, washers and nuts, and tighten the nuts to the specified torque.

Torque: 33 N·m (3.3 kg-m, 24 ft-lb)

NOTE

- It is important to hold the bolts while tightening the nuts to achieve proper torque.

Pack the dust seal lip with grease and install the left dust seal. Install the left side collar.

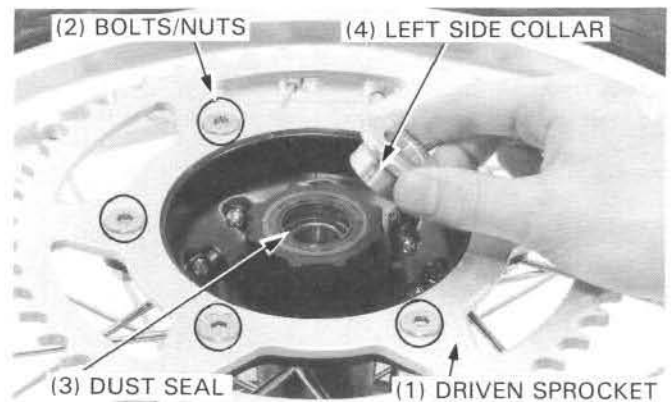

Installation

Install the rear brake caliper by aligning the bracket with the slide rail on the swingarm.



Apply thin layer of grease to the axle.

Insert the rear axle into the left chain adjuster.

Insert the axle from the left side into the swingarm, through the rear wheel and rear brake caliper, and into the right side chain adjuster.

Install the drive chain.

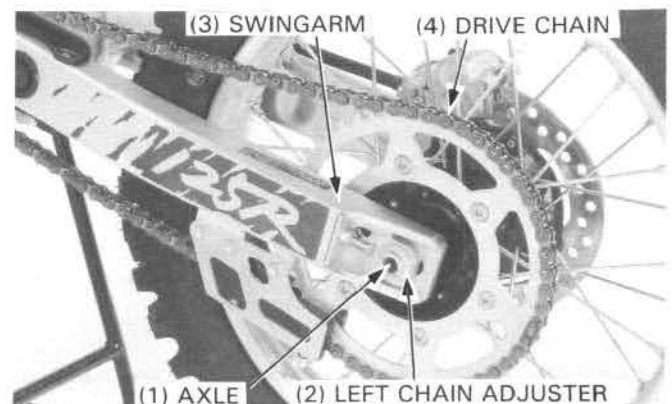

Rear Wheel/Suspension

If the master link retaining clip was removed, install it on the drive chain with the closed end of the clip in the direction of wheel rotation.

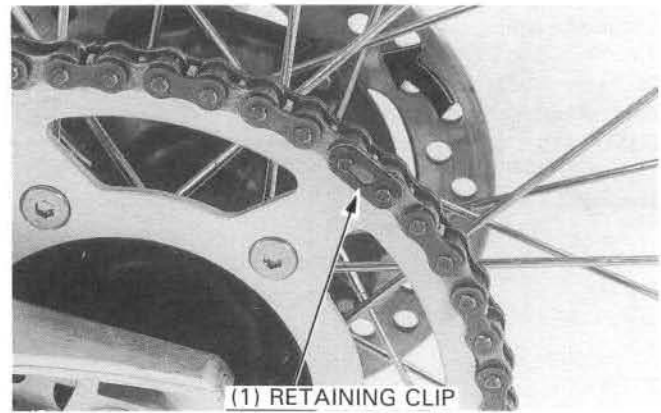

Install the rear axle nut.

Check the drive chain slack and adjust as required.
Tighten the rear axle nut to the specified torque.

Torque: 95 N·m (9.5 kg·m, 69 ft·lb)

Snug the adjusting bolts against the chain adjusters and tighten the lock nuts.

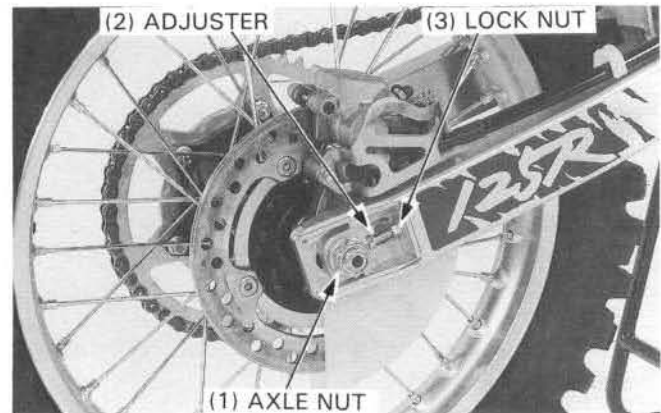

Shock Absorber

Removal

⚠ WARNING

- Use only nitrogen to pressurize the shock absorber. The use of an unstable gas can cause a fire or explosion resulting in serious injury.
- The rear shock absorber contains nitrogen gas under high pressure. Do not allow fire or heat near the shock absorber.
- Before disposal of the shock absorber, release the nitrogen by pressing the valve core. Then remove the valve from the shock absorber.

Raise the rear wheel off the ground by placing the box or work stand under the engine.

Remove the seat and sub-frame (Section 2).

Remove the rear shock absorber upper mounting bolt.

NOTE

- If you plan to disassemble the shock absorber, loosen the spring lock nut and adjusting nut.

Remove the shock absorber lower mounting bolt and pull the rear shock absorber up and out of the frame.

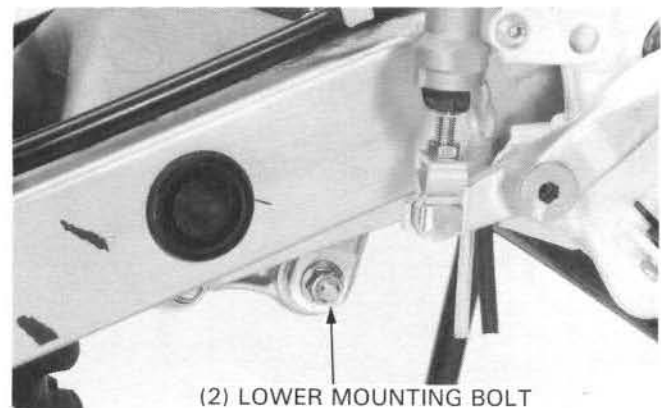

Disassembly

Hold the shock absorber in a vise by the reservoir, protected on both sides by pieces of wood.

Measure and record the assembled shock spring length for installation later.

Loosen the lock nut and adjusting nut.

S. TOOL

Pin spanner A

89201-KS6-810 x 2

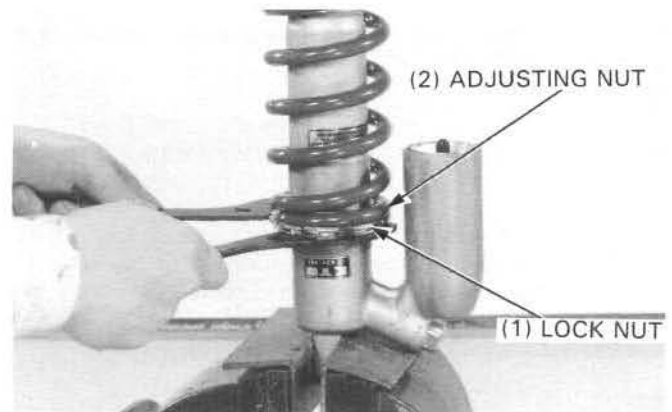

Remove the spring seat and spring.

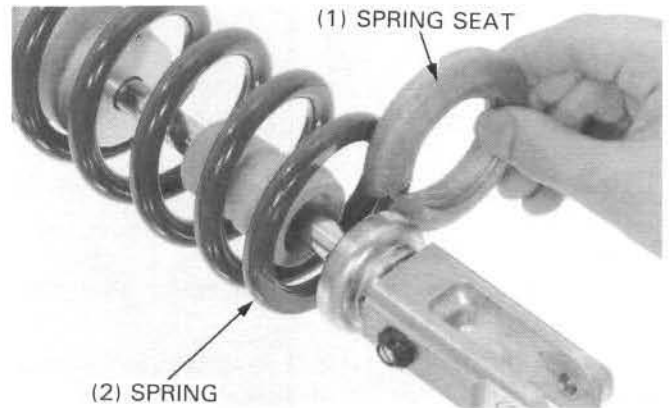

Bladder Replacement

NOTE

- Replace the bladder when oil leaks around the chamber cap or oil spills out when releasing the nitrogen from the reservoir.
- Perform this procedure before draining the oil from the damper.

Depress the valve core to release the nitrogen from the reservoir.

WARNING

- Release all nitrogen pressure before disassembly; otherwise the chamber cap will be under significant pressure and could cause reverse injury or death.
- Wear protective clothing and adequate eye protection to protect against injury and prevent debris from getting in your eyes.
- Point the valve away from you to prevent debris getting in your eyes.

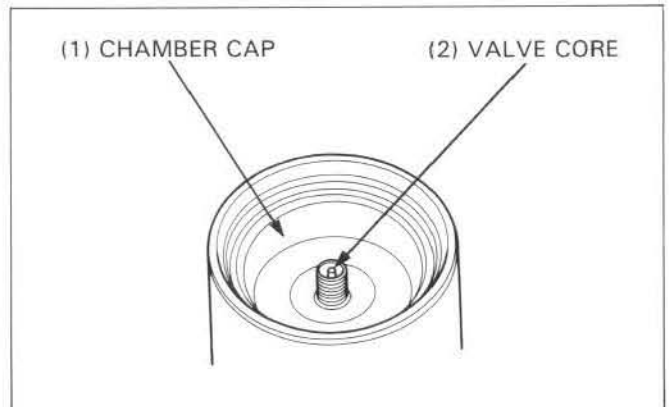

Remove the valve core.

Put a suitable tool on the chamber cap and push it in by lightly tapping on the tool with a plastic hammer until you have good access to the stop ring.

CAUTION

- To avoid damage the threads of the gas valve, install the cap before depressing the chamber cap.

NOTE

- Depress the chamber cap just the minimum amount necessary for stopper ring access.

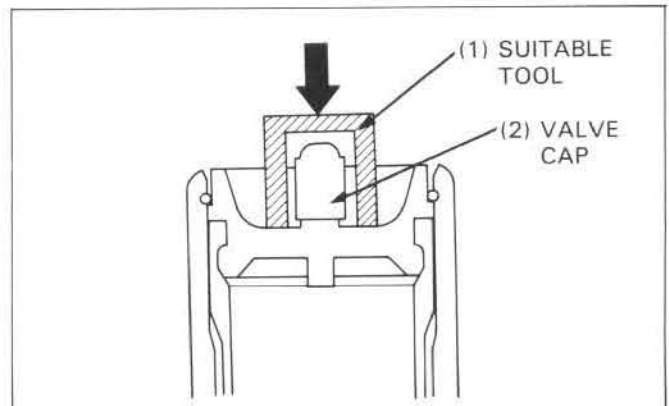

Rear Wheel/Suspension

You'll need two small screwdrivers and a shop towel to remove the stop ring.

The stop ring groove in the reservoir is ramped toward the inside to give the stop ring a square shoulder on which to seat securely.

CAUTION

- To avoid damage the inside surfaces of the reservoir, cover the screwdriver with shop towel.

To remove the stop ring, first push one end of the stop ring out of its groove, then slip the second screwdriver between the stop ring and the reservoir to act as a ramp.

Now, use the other screwdriver to pull the stop ring completely out.

NOTE

- Check the stop ring groove for burrs. Remove any burrs with fine emery cloth before pulling the damper rod out of the case.

Hold the shock absorber in a vise with shop towel or soft jaws. Using a suitable squeeze bottle, fill the reservoir with the recommended shock oil.

Recommended shock oil: Honda Suspension Fluid SS-7 or equivalent

Slowly pump the damper rod until no air bubbles appear in the valve core hole, then pull the damper rod all the way.

Install the valve core securely.

Remove the chamber cap and bladder following the procedure below:

Wrap a shop towel around the chamber cap.

1. Compress the damper rod slowly, to force the chamber cap out.

WARNING

- The chamber cap will be removed with hydraulic pressure so its force can be significant considering the air in the bladder. Wear protective clothing and a face guard to protect your eyes and face in case the chamber cap pops out quickly and forcibly.

2. Place the damper in a vise with soft jaws with the damping adjuster facing up. Being careful not to distort the damper body.

CAUTION

- Do not overtighten the vise. Damage to the shock body will result.

Remove the damping adjuster.

3. Fill the damper with shock oil through the damping adjuster hole, while slowly pulling the damper rod out.
4. Reinstall the damping adjuster after filling the damper.

NOTE

- The damper must be kept upright to prevent oil from leaking out of the damper.

5. Place the damper with the reservoir chamber cap facing up.
6. Repeat step 1 to 5 until the chamber cap is removed from the reservoir.

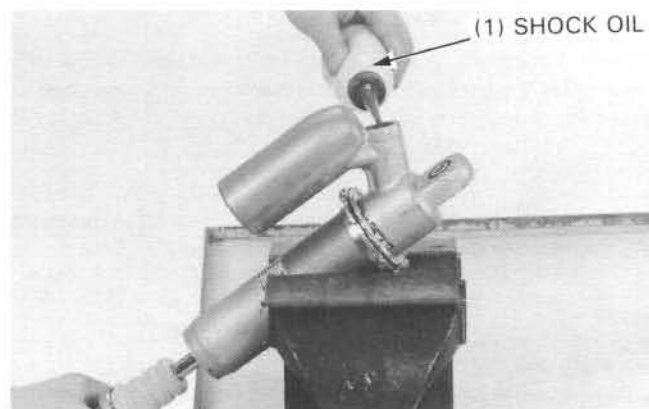
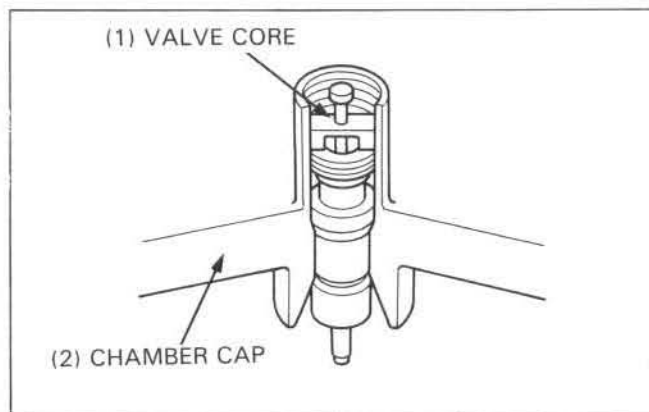
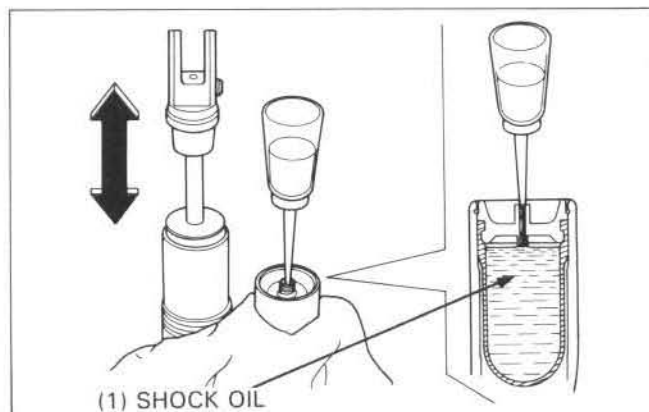
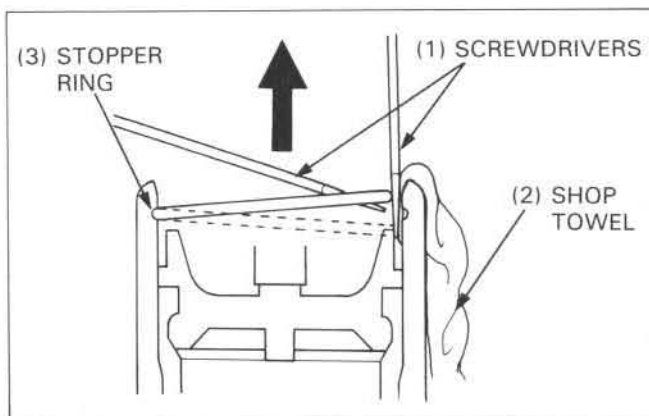

Remove the bladder from the chamber cap.

CAUTION

- Do not use any sort of tool to remove the bladder, because it may damage the chamber cap.
- Replace the bladder with a new one. Do not reuse the removed one.

Attach the new bladder to the chamber cap.

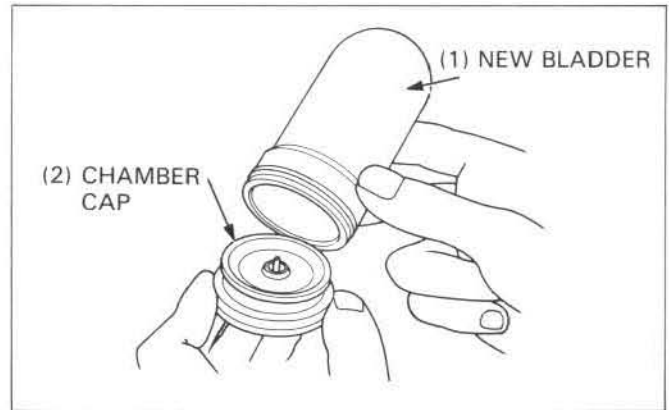

If the bladder becomes distorted during installation, depress the valve core to reform it.

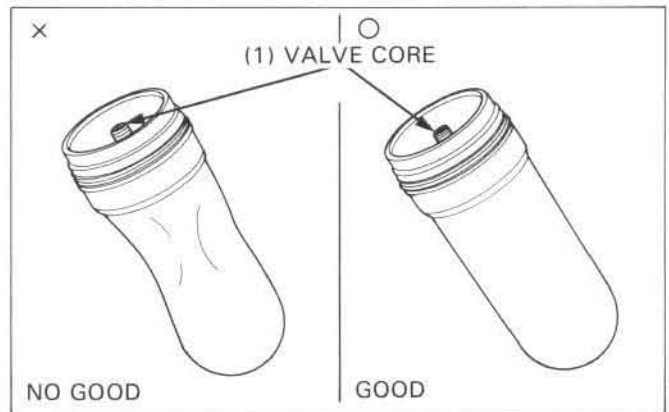

Clean the inside the reservoir and fill it with recommended shock oil.

Recommended shock oil: Honda Suspension Fluid SS-7 or equivalent

Apply a light coating of shock oil to the lip of the bladder, and press the chamber cap in the reservoir to about 1–2 mm (0.04–0.08 in) below the stop ring groove.

Install the stop ring to the groove of the reservoir securely. Temporarily fill the reservoir with 7.1 psi (49 kPa) of air slowly until the chamber cap seats against the stop ring.

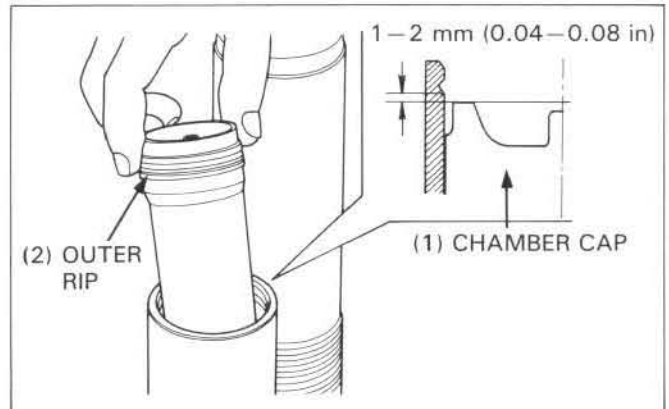

▲ WARNING

- Be sure the stop ring is seated in the ring groove all the way around or the chamber cap can come apart when riding the motorcycle.

Then make sure that chamber cap face is equal height level with reservoir face.

▲ WARNING

- If the chamber cap does not seat fully, the chamber cap may fly out wohen filling the reservoir with nitrogen.

Release the air from reservoir by depressing the valve core. Bleed the air from the shock absorber (page 12-19). Fill the reservoir with nitrogen to the specified pressure (page 12-20).

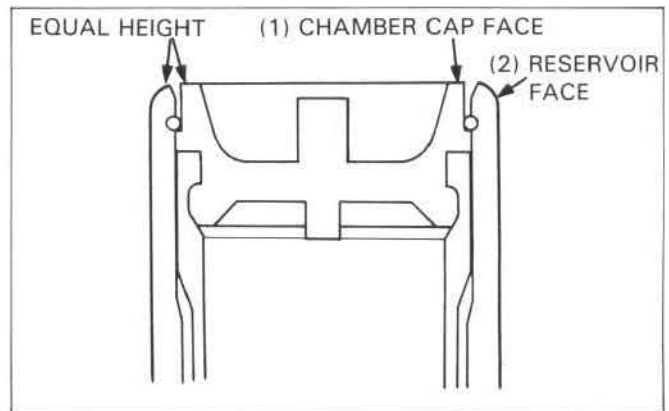

Rear Wheel/Suspension

Damper Disassembly

Depress the valve core to release the nitrogen from the reservoir (page 12-8).

⚠ WARNING

- Point the valve away from you to prevent debris getting in your eyes.
- Before disposal of the shock absorber, release the nitrogen by pressing the valve core. Then remove the valve from the shock absorber.

Remove the damping adjuster.

Drain most of the shock oil from the damper and reservoir, by pumping the damper rod in and out several times.

Clamp the shock absorber in a vise at the damper case protected on both sides by pieces of wood.

Remove the end plate and tape or tie it to the bump rubber so it won't get in the way.

Push in the damper seal until you have good access to the stop ring.

You'll need two small screwdrivers to remove the stop ring. The stop ring groove in the damper case is ramped towards the inside to give the stop ring a square shoulder on which to seat securely.

To remove the stop ring, first push one end of the stop ring out of its groove, then slip the second screwdriver between the stop ring and the damper case to act as a ramp.

Now, use the other screwdriver to pull the stop ring completely out.

CAUTION

- Burrs will damage the damper rod piston ring.

NOTE

- Check the stop ring groove for burrs. Remove any burrs with fine emery cloth before pulling the damper rod out of the case.

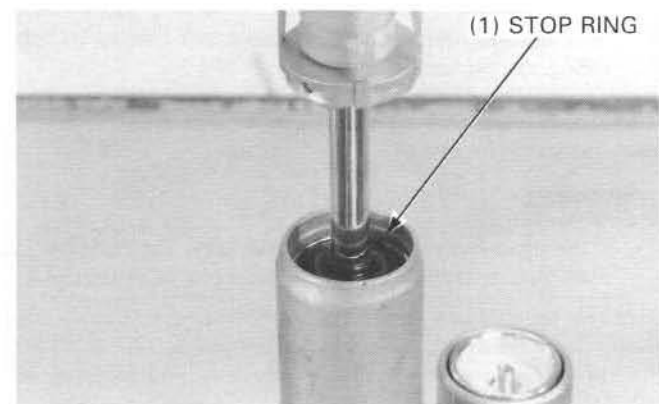
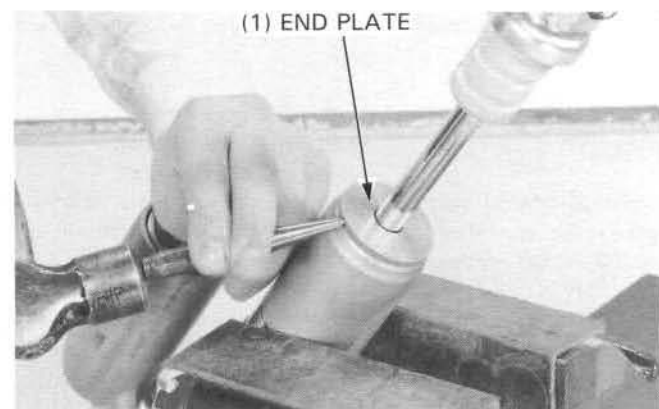
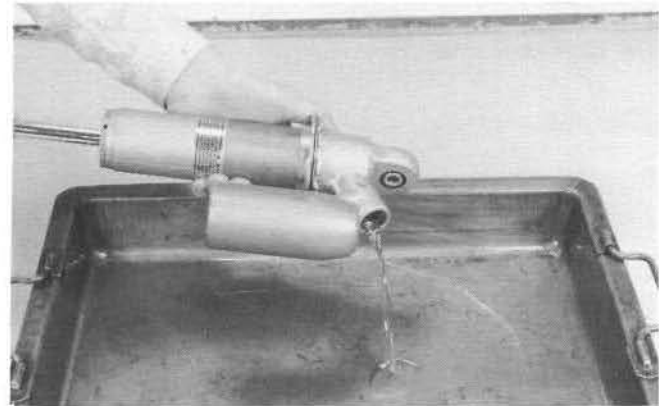
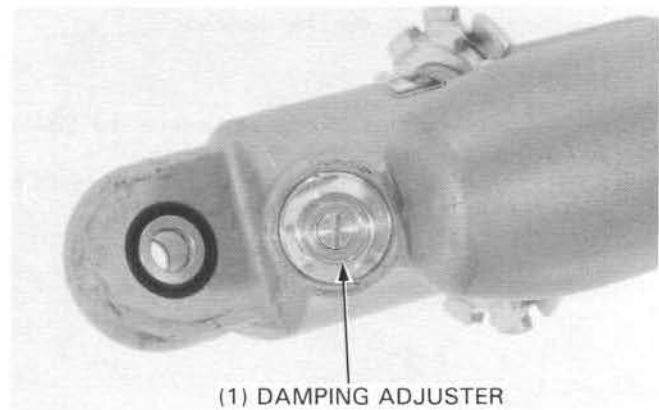

Carefully pull the damper rod assembly out of the damper case.

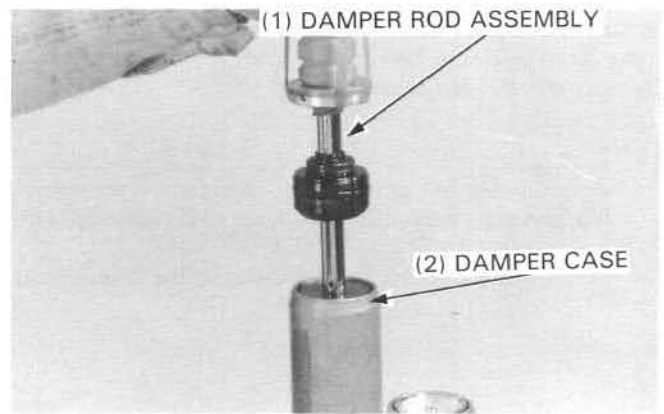

Piston Ring Replacement

Inspect the piston ring.
If the piston ring is damaged, cut the piston ring and replace the piston ring and O-ring under the piston ring with a new one.

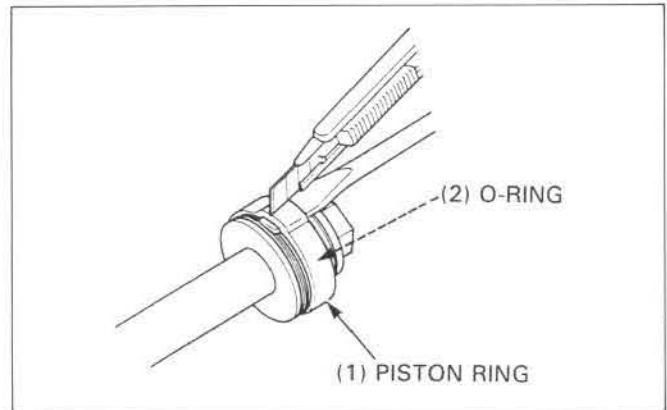

Place the slider guide attachment over the piston and drive a new O-ring, piston ring into place with the sleeve collar.

S TOOL

Sleeve collar
Slider guide attachment

07974-KA30201
07974-KA50101

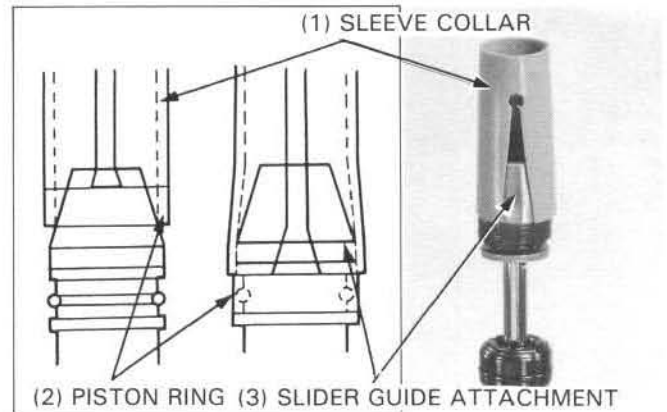

Damper Rod Disassembly

CAUTION

- To keep lint or dirt from getting onto damper rod parts, do not wear gloves while working on the damper rod.
- Be careful to grind the end nut so that the O.D. of the rod end is about 10 mm (0.04 in). Be careful too not to over grind.

Unstake the damper rod end nut with a grinder as shown.

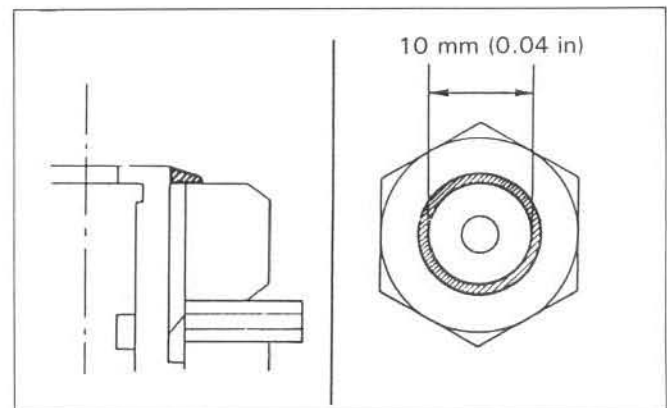

Rear Wheel/Suspension

Place the damper in a vise with soft jaws or shop towel, being careful not to distort the lower mount. Remove the end nut and discard it.

NOTE

- If the damper rod is cracked or damaged when removing the end nut, replace the damper rod assembly with a new one.
- Remove the all burrs from the end of the damper rod.

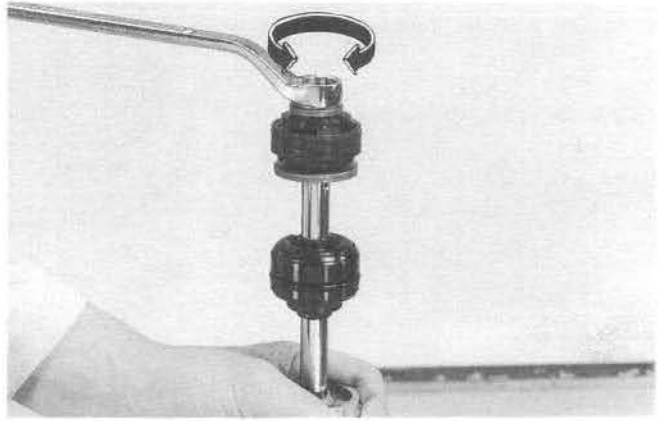

Remove the washers, valve stopper, rebound valves and piston from the damper rod.

NOTE

- Pass a piece of thin wire through the removed valves to ensure correct reassembly.
- Keep dust and abrasives away from all damper rod parts.
- Thoroughly clean the valves in solvent and blow them dry with compressed air. If they have been disassembled and separated.
- Be careful not to get solvent on the O-ring, piston ring.
- The valve arrangement and number of valves shown is typical.

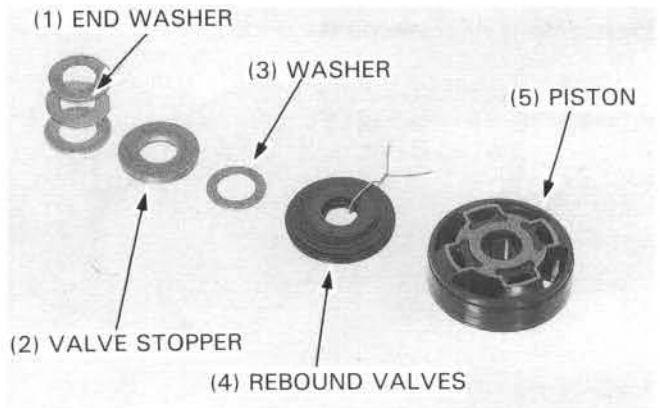

Remove the compression valves, washers and valve stopper.

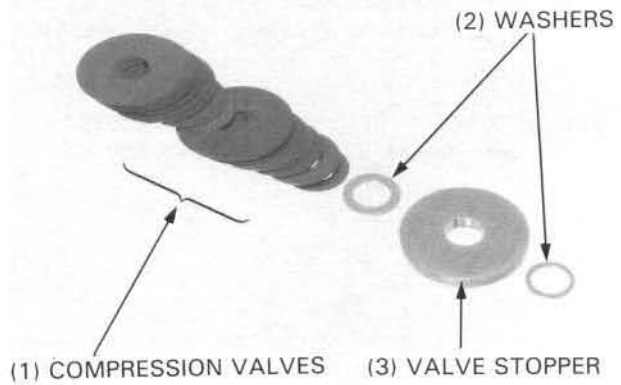

Wrap the top threads of the damper rod with tape.

Remove the rod guide case from the damper rod. Remove the end plate, bump rubber and rubber seat from the damper rod.

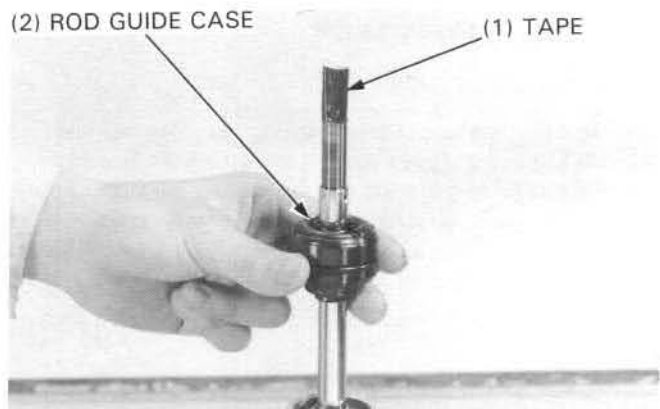

Rod Guide Case Inspection

Inspect the rebound rubber for wear or damage and replace the rod guide case with a new one.

Inspect the dust seal lips for wear, scratch or damage and replace the rod guide case with a new one.

Visually inspect the rod guide case metal. If the metal is worn so that the copper surface appears, replace the rod guide case with a new one.

Remove the O-ring from the rod guide case and replace it with a new one.

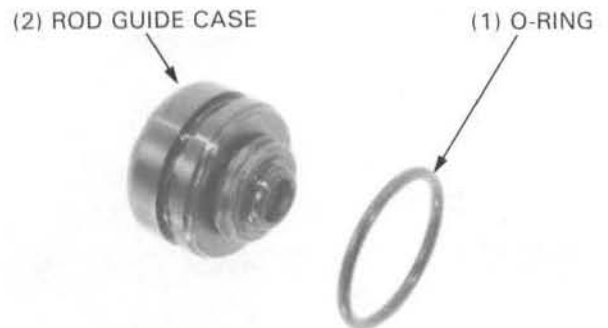

Damper Rod Inspection

Inspect the damper rod sliding surface for damage or distortion.

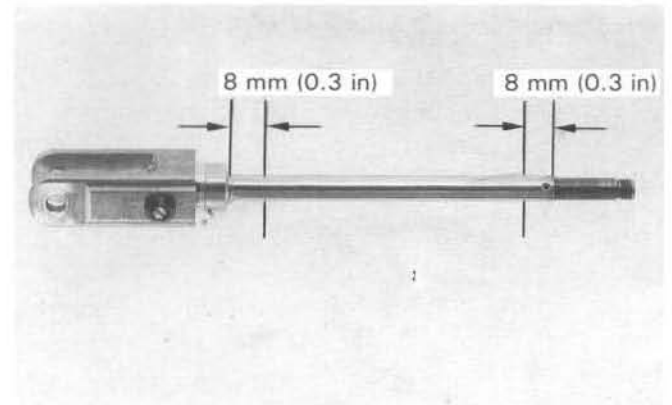

Rear Wheel/Suspension

Damper Assembly

Before assembly, wash all parts with solvent and blow them dry with compressed air.
Be sure that there is no dust or lint on any of the parts.

NOTE

- Never assemble valves which might have gotten dusty or otherwise contaminated during the disassembly process. Disassemble them, thoroughly clean with solvent and blow them dry with compressed air before assembly.

CAUTION

- Use added care to avoid getting solvent on the piston ring and O-ring.
- The valve arrangement and number of valves may differ from those shown.

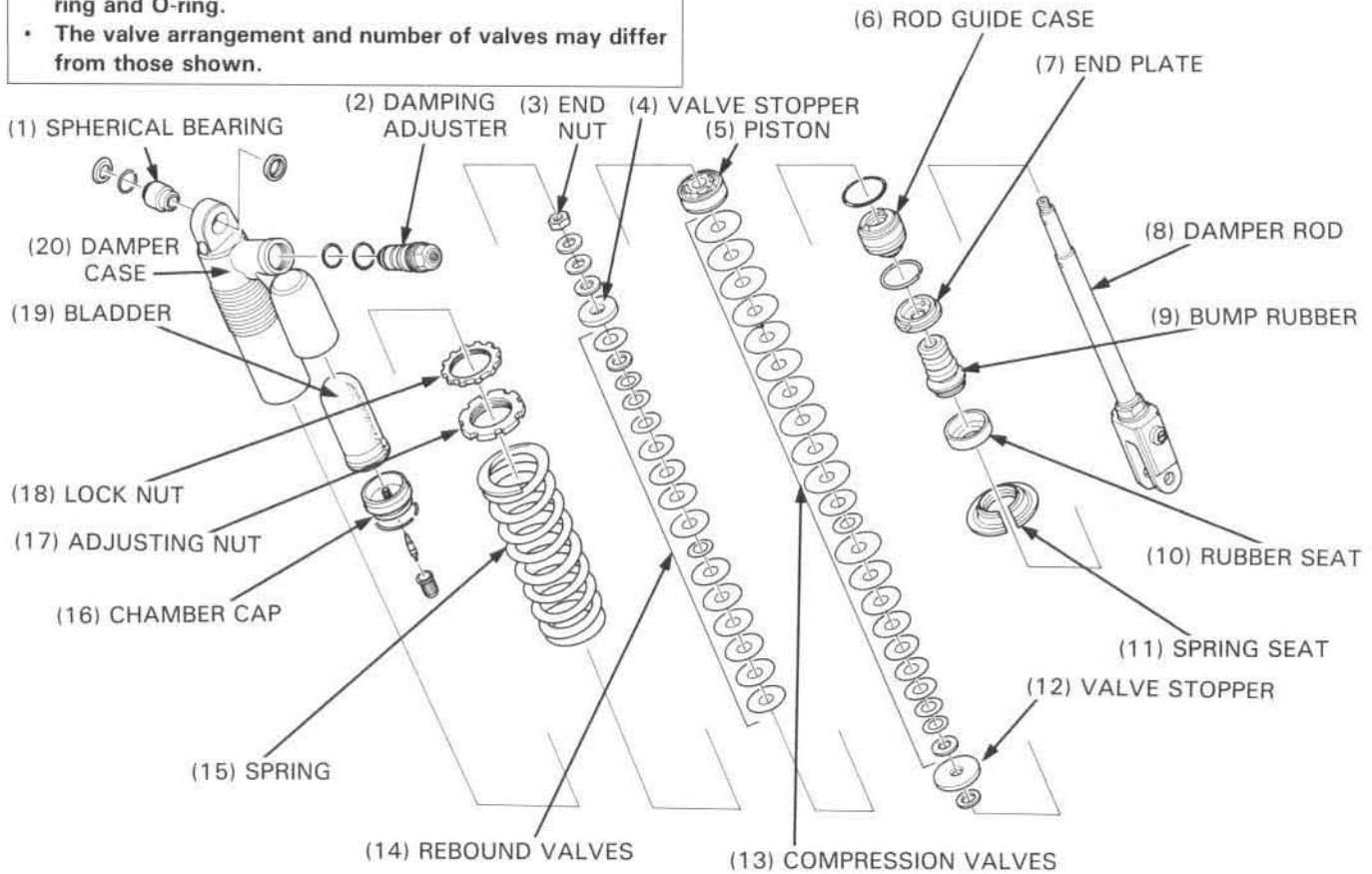

Hold the lower shock mount in a vise with soft jaws or a shop towel.
Clamp in a vise with soft jaws or use a shop towel around the lower mount.

Remove the burrs from the damper rod end with a file and correct the threads with a die.

DIE: 12 x 1.5 mm

Clean the damper rod with solvent after correcting the threads.

NOTE

- Make sure that burrs are not stuck in the damper rod I.D.

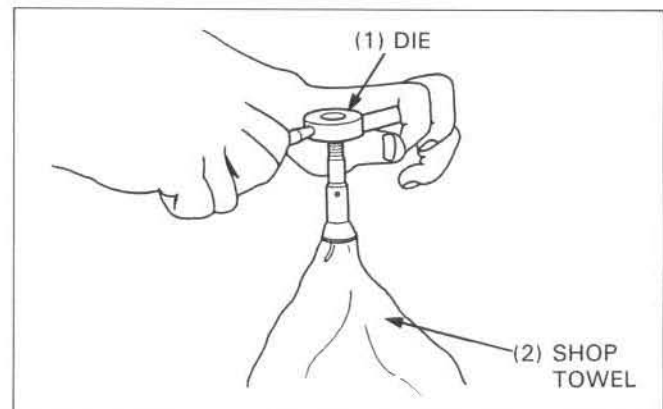

Install the rubber seat, bump rubber and end plate.

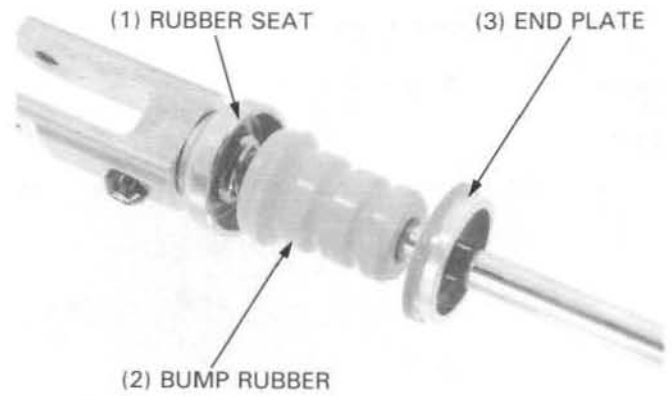

Install the special tool onto the damper rod.



Slider guide, 14 mm

07974-KA40001

Install the rod guide case with the rebound rubber facing up, carefully over the damper rod.

NOTE

- The rod guide case oil seal is filled with grease.
- Be careful not to remove grease from the seal.
- Be careful not to damage the dust seal lip or turn it inside out.

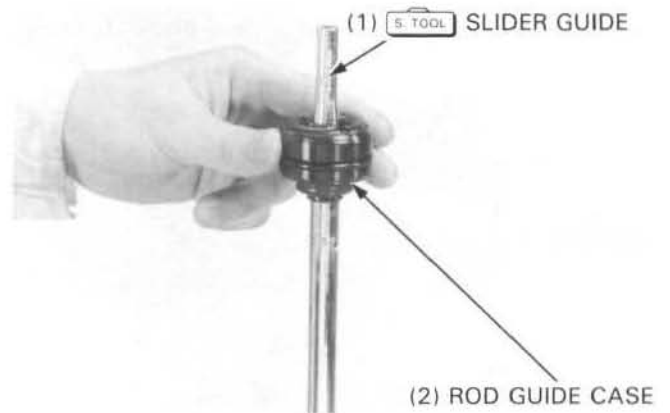

Remove the special tool.

Install the washers, valve stopper and compression valves onto the damper rod.

NOTE

- The valve arrangement and number of valves shown is typical.

Install the piston onto the damper rod.

Install the rebound valves with its polished surface facing down.

Install the valve stopper.

NOTE

- Do not install the end washer, except using the new damper rod.
- Note the installation direction of the piston and valves.
- Be careful not to bind the valves when installing the piston onto the damper rod. Also, check that they are concentric with the damper rod.

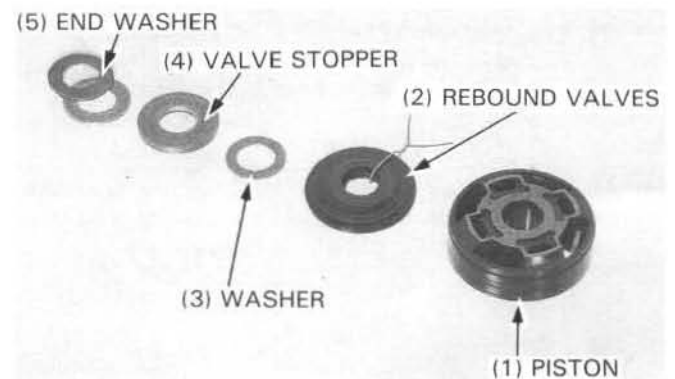
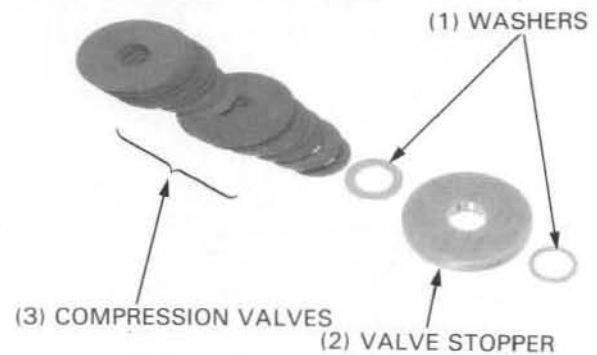

Rear Wheel/Suspension

Install and tighten the new end nut to the specified torque.

Torque: 27 N·m (2.7 kg-m, 20 ft-lb)

NOTE

- To prevent damage to the lower mount, use a shop towel or a vise with soft jaws.

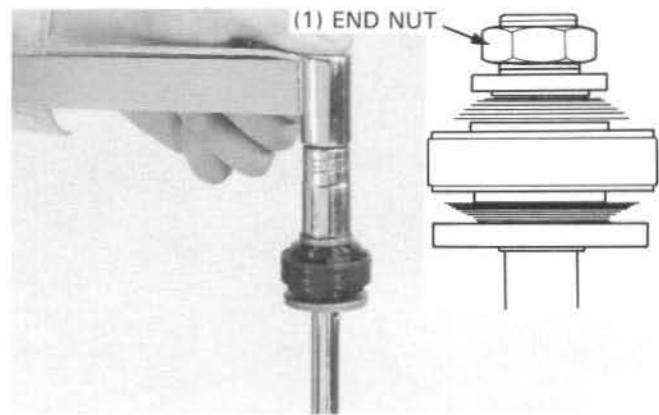

Stake the end of the damper rod in three places as shown to secure the end nut.

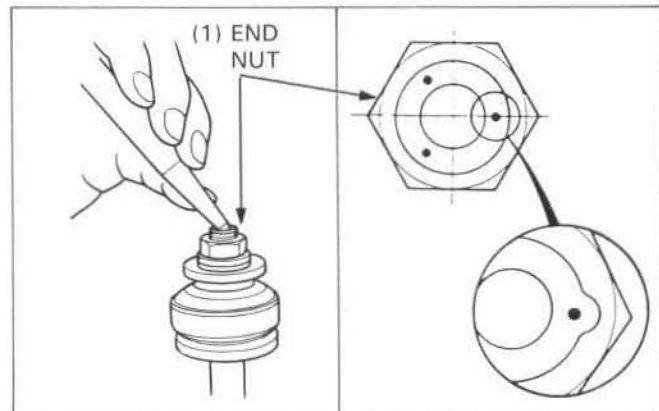

Coat the damper rod with Honda Suspension Fluid SS-7 or equivalent. Check the rod guide case by sliding it up and down fully to be sure there is no restriction.

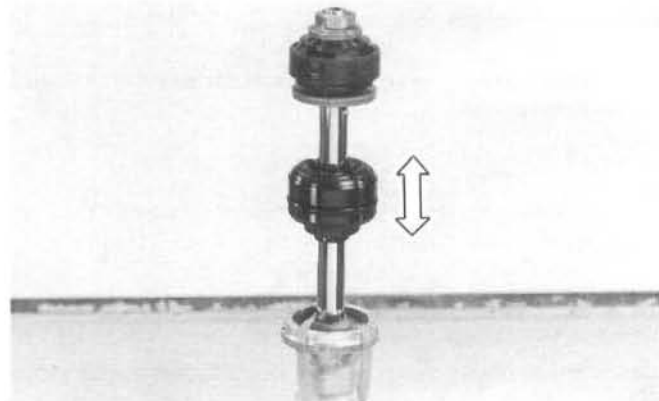

Coat the damper case inner surface, piston ring and O-ring with Honda Suspension Fluid SS-7 or equivalent, and insert the damper rod assembly carefully. Install the stop ring into the groove in the damper case.

NOTE

- After assembling, check that the stop ring is seated in the groove of the damper case completely. You should not be able to pull it out of the damper case.

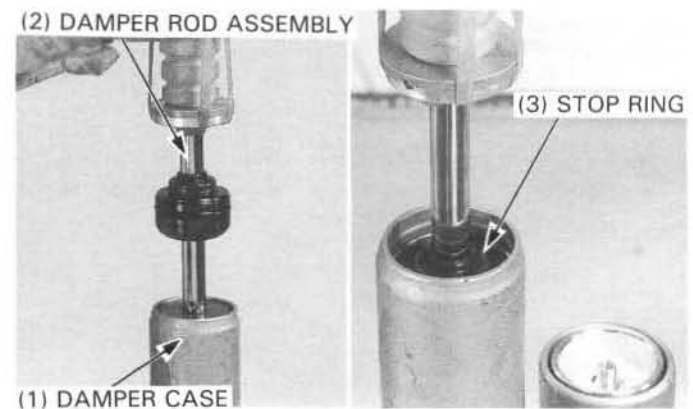

Drive the end plate squarely and evenly into the damper case with a plastic hammer.

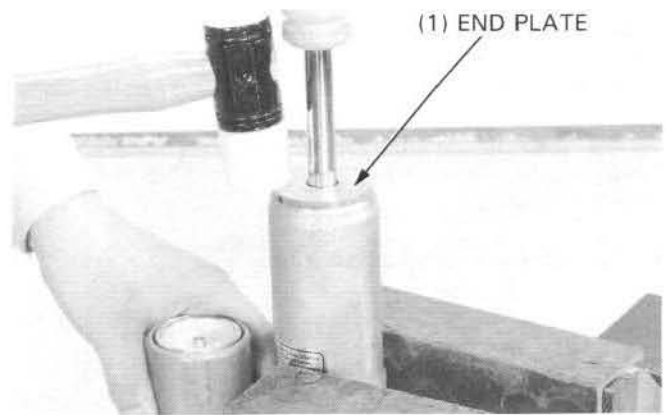

Hold the shock absorber gently in a vise by the damper case protected on both side by pieces of wood.

CAUTION

- Do not overtighten the vise and distort the damper case.

Fill the damper case and reservoir with recommended oil through the damping adjuster hole.

Recommended shock oil: Honda Suspension Fluid SS-7 or equivalent

Slowly pump the damper rod until there are no bubbles in the oil that overflows from the damper case.

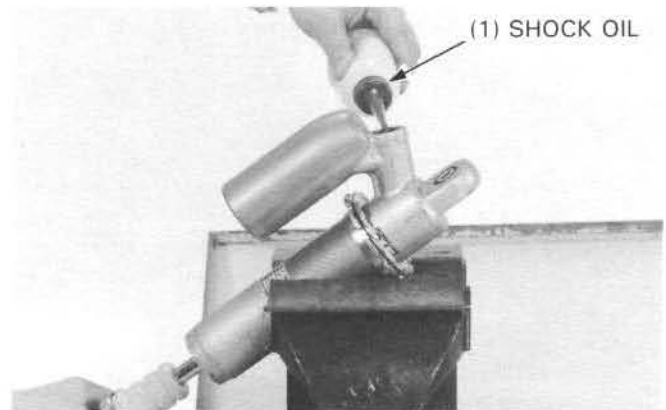

NOTE

- Make sure the rod guide case is seated against the stop ring by pulling the damper rod out all the way.

Remove the damper unit from the vise.

Position the damper the damping adjuster hole facing up. Turn the damper unit as shown to bleed the air from the reservoir completely.

NOTE

- When bleeding air from the reservoir, be careful to hold the damper at the angles shown so the filler hole points up.

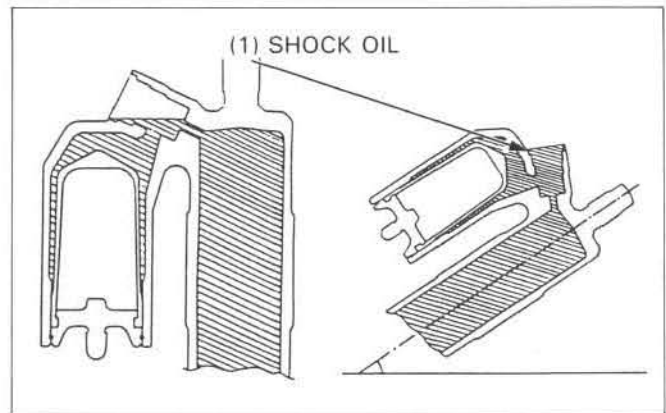

NOTE

- Do not let oil flow out of the reservoir.

Temporarily charge the reservoir with 7.1 psi (49 kPa, 0.5 kg/cm²) of air slowly to inflate the bladder inside.

NOTE

- Check for any oil that may leak out of the valve while pressurizing. Replenish oil as necessary. Be sure that the reservoir pressure is correct with an accurate pressure gauge.



Rear Wheel/Suspension

Fill the damper with the recommended shock oil up to the damping adjuster hole neck.
Apply oil to the new O-rings and install them to the damping adjuster.
Dip the damping adjuster in clean shock oil.
Slowly install the damping adjuster, and tighten it to the specified torque.

Torque: 20 N·m (2.0 kg-m, 14 ft-lb)

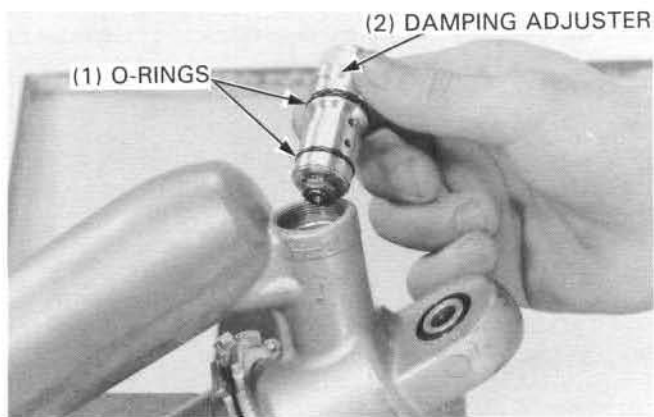

Stake the damping adjuster as shown.

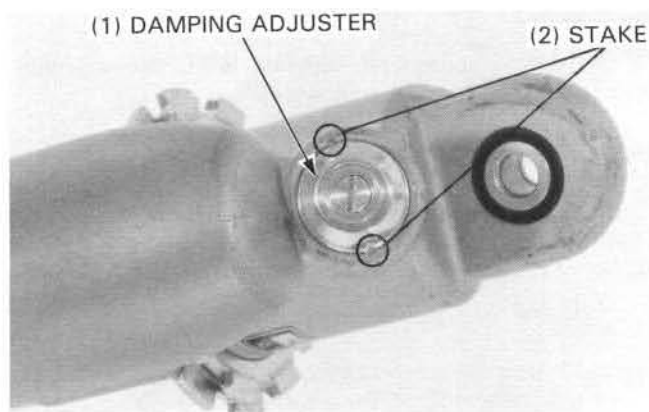

Wipe off all oil from the damper rod; oil left on the damper rod can lead to premature failure of the oil seal.
Check for oil leaks.

Release the 7.1 psi of air that was in the reservoir at precompression.
Fill the reservoir with 142 psi (981 kPa, 10.0 kg/cm²) of nitrogen gas.

▲ WARNING

- The shock absorber is fitted with a gas-filled reservoir. Use only nitrogen gas to pressurize the shock absorber. The use of an unstable gas can cause a fire or explosion resulting in serious injury.

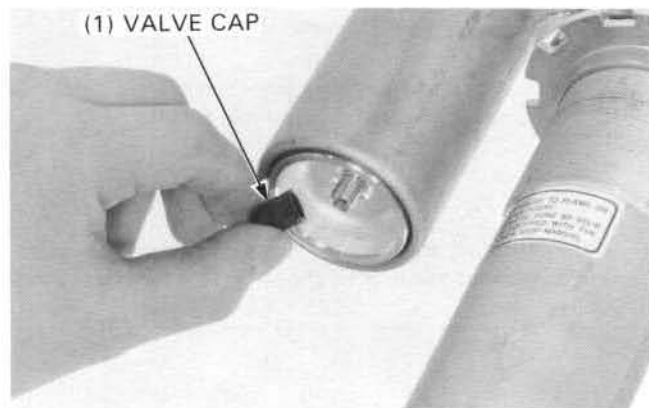

Install the valve cap.

Install the shock spring with its narrow wound end facing down.

Install the spring seat.

Temporarily tighten the adjusting nut and lock nut.

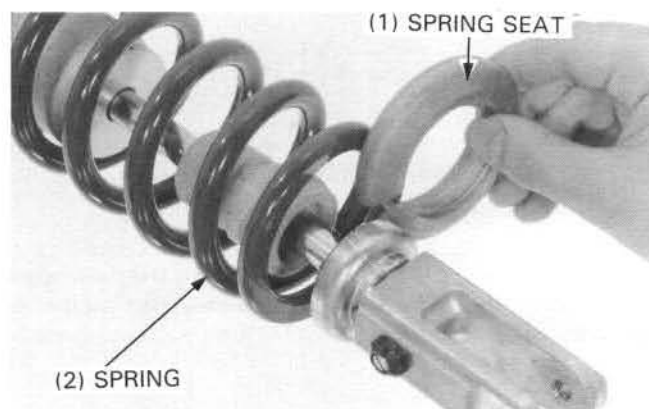

Turn the shock absorber lower mount so that the rebound adjuster screw is on the same side of the shock as the reservoir as shown.

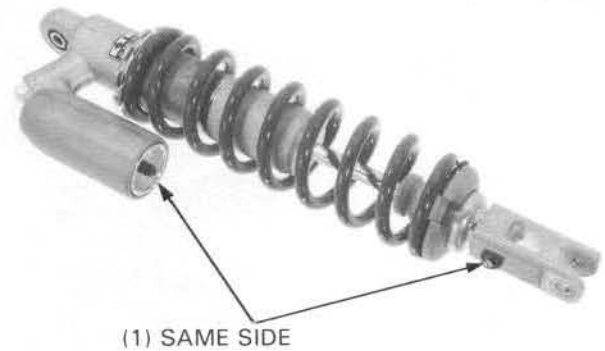

Turn the spring adjusting nut until the spring length measurement recorded at disassembly is reached or until the spring length is as specified below.

Standard spring length: 255.0 mm (10.04 in)

NOTE

- One turn of the adjusting nut changes the spring length by 1.5 mm (0.06 in).

Hold the adjusting nut and tighten the lock nut.

Torque: 90 N·m (9.0 kg-m, 65 ft-lb)

Use this standard spring length is just as a baseline. See the Owner's Manual for detail instructions on adjusting preload and damping settings for rider weight and setting damping for riding conditions and rider skill.

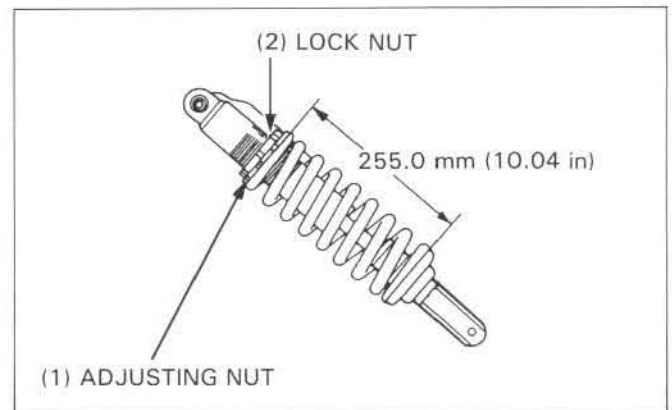

Spherical Bearing Replacement

Check the spherical bearing for wear or damage. If it is worn or damaged, it must be replaced.

Remove the upper collars and dust seals.

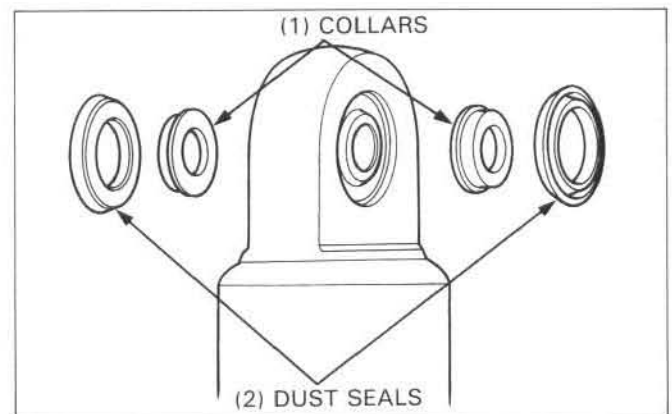

- Assemble the following items for the bearing replacement:
- Metal tubing for the base holder: I.D. 26.5 mm over.
 - Metal tubing for the driver: O.D. 23 x 20 mm length.
 - Flange bolt and nut: thread dia. 10 mm
 - Two suitable washers for the tubing: O.D. 26.5 mm over.

Assemble these items onto the upper mount as shown. Tighten the bolt and nut to get the clearance to access to remove the stop ring. Remove the stop ring.

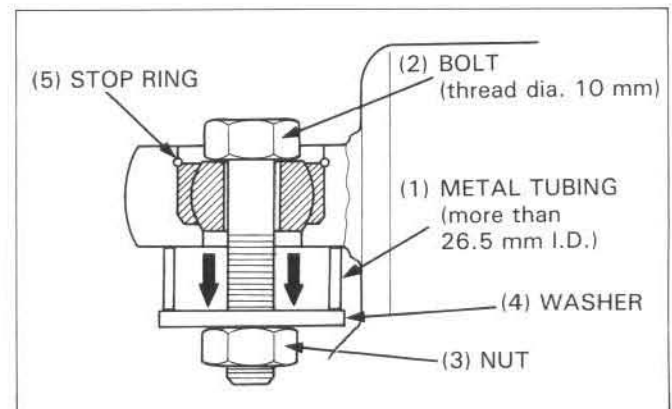

Rear Wheel/Suspension

Tighten the bolt and nut and pull the spherical bearing out of the upper mount.

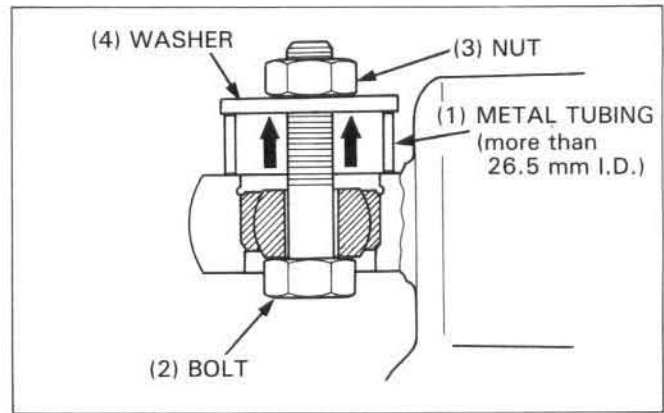

Apply multi-purpose grease NLGI No. 2 (Molybdenum disulfide MoS₂ additive) to the new spherical bearing. Assemble the items onto the upper mount as shown. Tighten the bolt and nut and install the spherical bearing onto the upper mount.

NOTE

- Drive the bearing in evenly; do not allow it to tilt.

Disassemble the bolt, nut, washer and tubes.

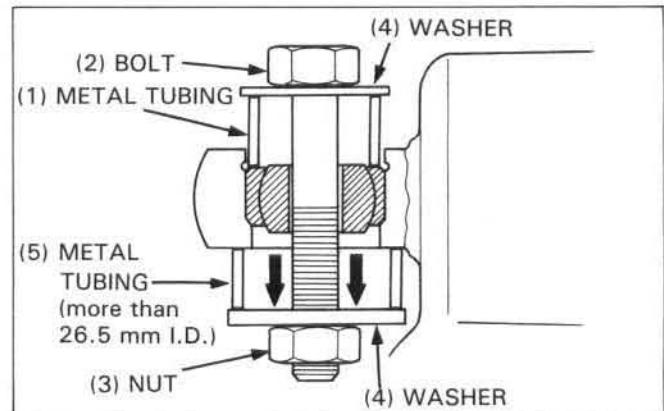

Install the new stop ring into the groove of the upper mount securely.

Assemble the items onto the upper mount as shown. Tighten the bolt and nut to press the spherical bearing into the upper mount until it seats against the stop ring end.

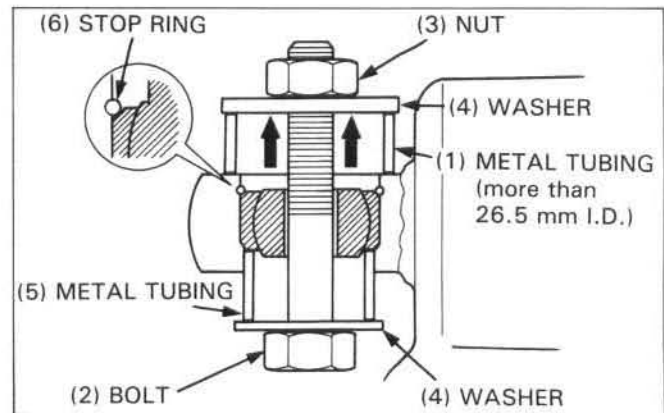

Apply grease to the lip of the new dust seals and install them. Install the collars.

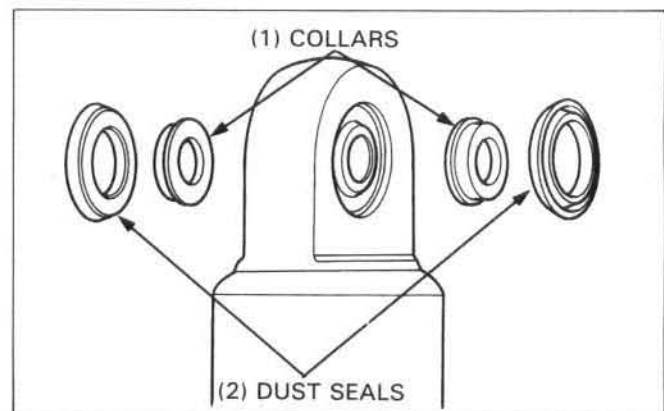

Installation

Set the shock absorber onto the shock arm with the rebound adjuster facing to the right.

Tighten the lower mounting bolt to the specified torque.

Torque: 43 N·m (4.3 kg-m, 31 ft-lb)

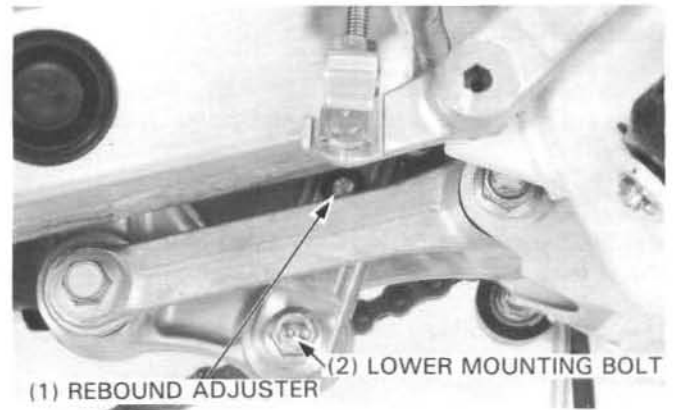

Install and tighten the rear shock absorber upper mounting bolt/nut.

Torque: 45 N·m (4.5 kg-m, 33 ft-lb)

Tighten the spring adjuster lock nut (page 12-21).
Install the sub-frame (page 2-4).

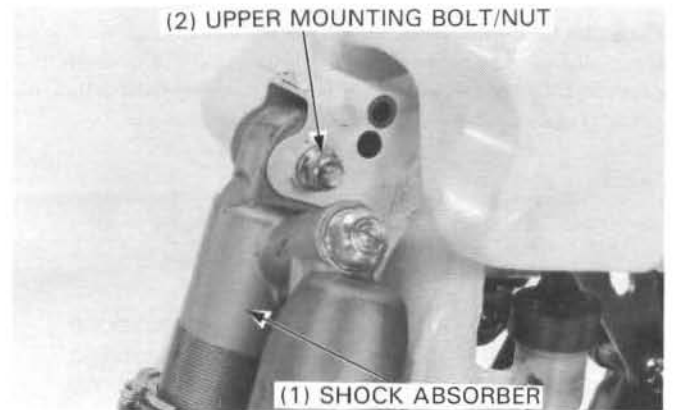

Shock Linkage

Removal

Remove the following:

- Lower chain guide roller
- Swingarm caps
- Shock absorber lower mounting bolt
- Shock arm bolt (swingarm side)
- Shock link bolt (frame-side)
- Shock linkage assembly

Disassemble the shock arm and shock link.

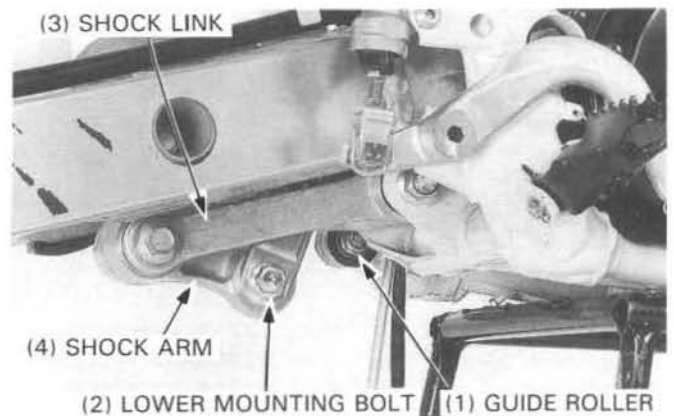

Remove the side collars, pivot collars, dust seals and washers. Inspect the shock arm/shock link collars, dust seals and needle bearings for wear or damage.

Inspect the spherical bearing for wear or damage. Replace any parts that have scratches, score marks, excessive or abnormal wear.

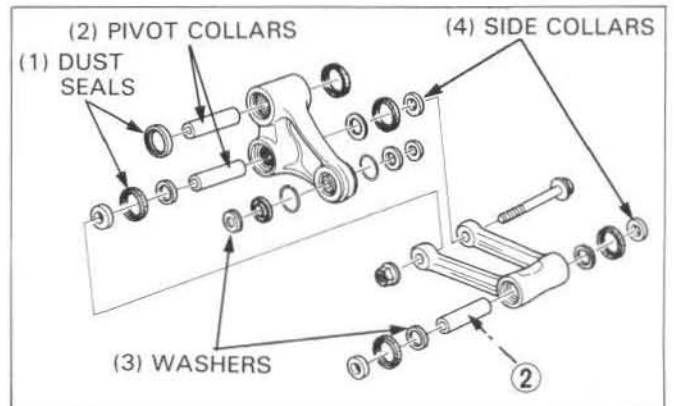

Rear Wheel/Suspension

Bearing Replacement

Shock Arm Needle Bearing:

Press out the needle bearings using the following tools.

S. TOOL

Swingarm side:

Needle bearing driver 07946-MJ00100

Driver head 07946-KM40701

Shock link side:

Needle bearing driver 07946-KA50000

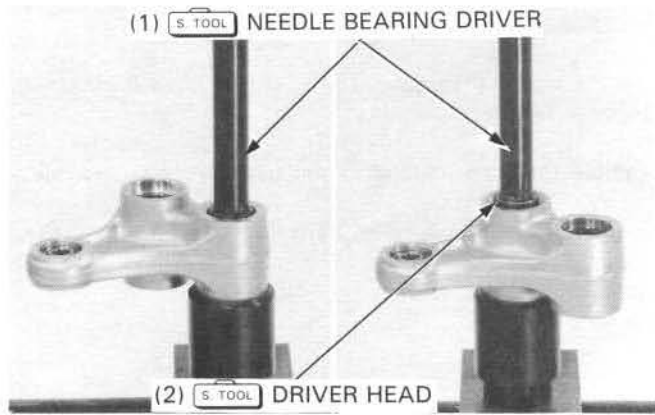

Pack the new needle bearings with grease.

Carefully press the needle bearings into the swingarm side pivot to 5.0–5.5 mm (0.20–0.22 in) below the surface of the pivot on both side.

NOTE

- Install the bearings with the marks facing out.

S. TOOL

Driver 07749-0010000

Attachment, 28 x 30 mm 07946-1870100

Pilot, 22 mm 07746-0041000

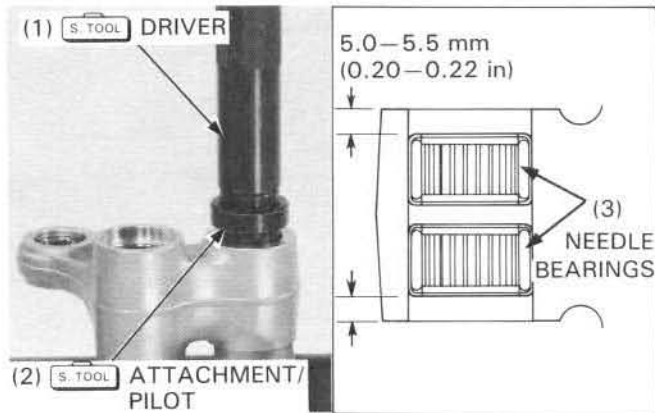

Pack the new needle bearings with grease.

Carefully press the needle bearings into the shock link side pivot to 7.0–7.5 mm (0.28–0.30 in) below the surface of the pivot on both side.

NOTE

- Install the bearings with the marks facing out.

S. TOOL

Driver 07749-0010000

Attachment, 24 x 26 mm 07946-0010700

Pilot, 20 mm 07746-0040500

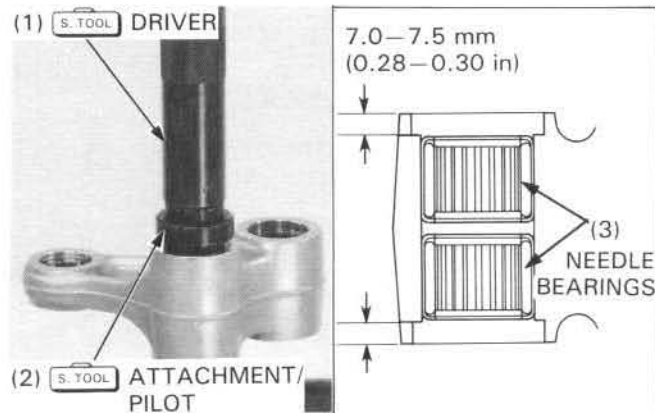

Shock Arm Spherical Bearing:

Remove the stop rings and press the spherical bearing out of the shock arm.

S. TOOL

Spherical bearing driver 07HMF-KS60100

Install the stop ring on one side and press the new spherical bearing using the same tool.

Install the stop ring in the opposite side.

Install the dust seals in the direction shown in the detail to right.

Install the side collars.

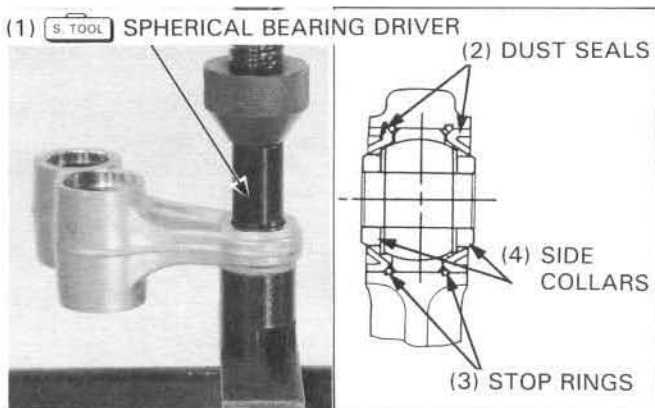

Shock Link Needle Bearing:

Remove the needle bearing using the special tool.

S. TOOL

Bearing remover, 17 mm 07936-3710001
 -remover handle 07936-3710101
 -remover weight 07741-0010201

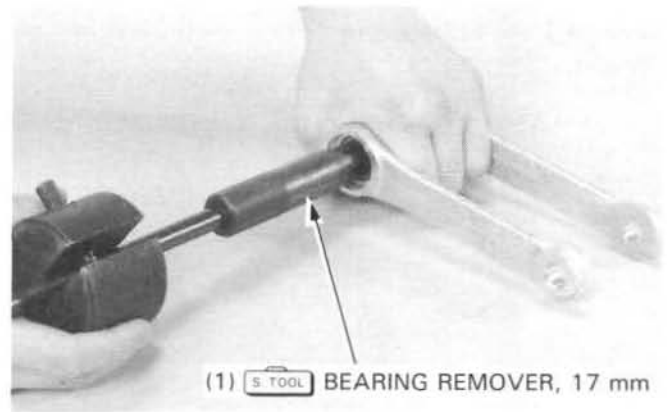

Pack the new needle bearings with grease.

Carefully press the needle bearing into the shock link pivot to 7.0-7.5 mm (0.28-0.30 in) below the surface of the pivot on both side.

NOTE

- Install the bearings with the marks facing out.

S. TOOL

Driver 07749-0010000
Attachment, 24 x 26 mm 07946-0010700
Pilot, 20 mm 07746-0040500

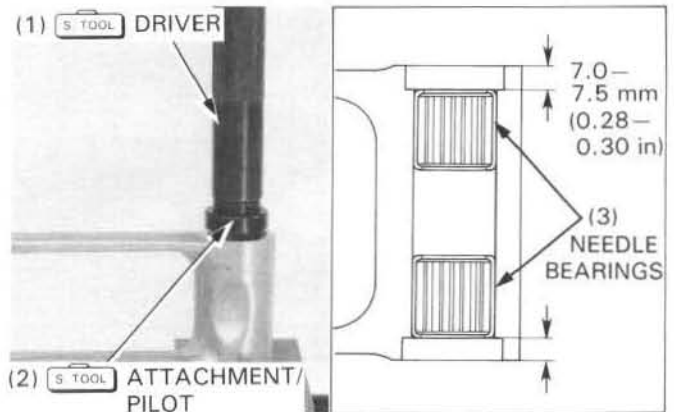

Apply multi-purpose grease NLGI No. 2 (molybdenum disulfide additive) to the shock linkage, collars bearings and dust seal lips.

Install the washers, dust seals, pivot collars and side collars.

NOTE

- Make sure that the needle bearing rollers are in position before installing the pivot collars.
 Number of needle rollers:
 Shock link: 33
 Shock arm: shock link side: 33
 swingarm side: 36

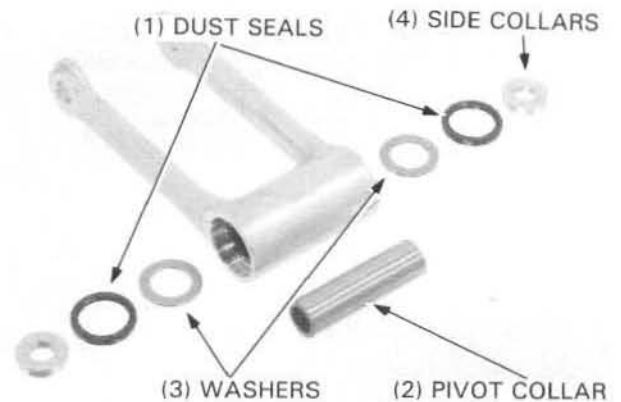
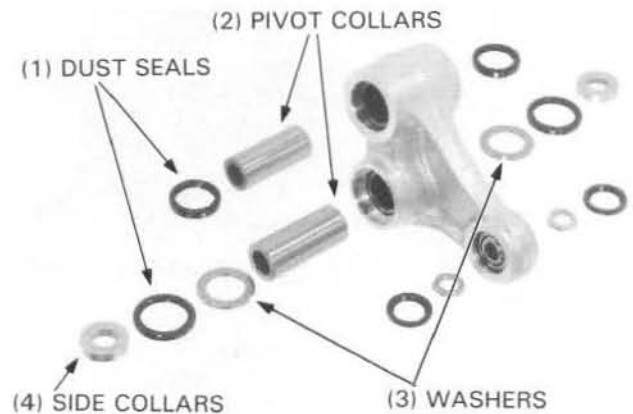

Rear Wheel/Suspension

Connect the shock link to the shock arm with the "UP" mark facing up.

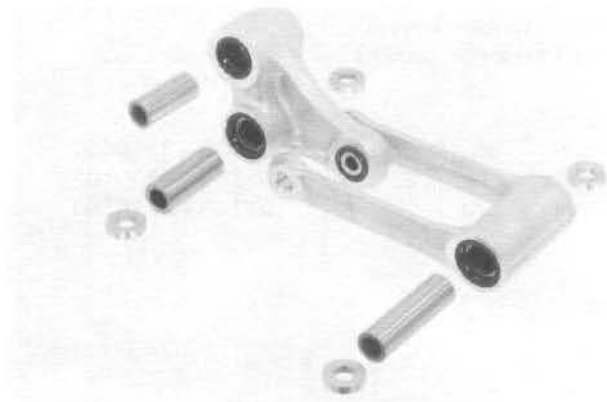

Installation

Install the shock linkage onto the swingarm. Tighten the shock link bolt (frame side).

Torque: 63 N·m (6.3 kg-m, 46 ft-lb)

Tighten the shock arm bolt (swingarm side).

Torque: 63 N·m (6.3 kg-m, 46 ft-lb)

Tighten the rear shock absorber lower mounting bolt.

Torque: 43 N·m (4.3 kg-m, 31 ft-lb)

Install the lower chain guide roller and tighten the bolt.

Torque: 22 N·m (2.2 kg-m, 16 ft-lb)

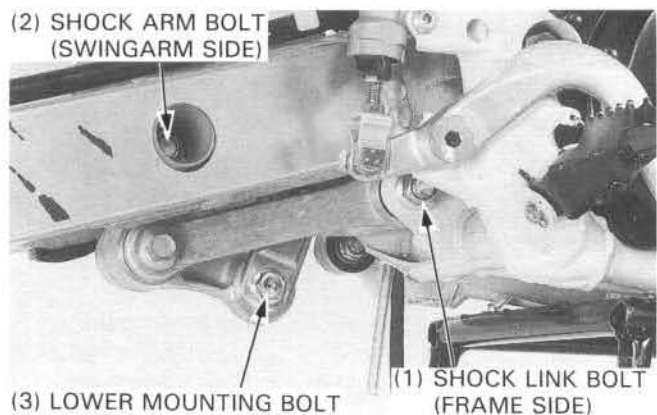

Swingarm

Removal

Raise the rear wheel off the ground with a box or workstand under the engine.

Remove the following:

- Rear wheel (page 12-3)
- Shock linkage (page 12-23)
- Brake pedal (page 13-14)

Remove the brake hose guide and brake hose. Disconnect the carburetor tubes from the clamps.

Remove the drive chain clip and drive chain. Remove the swingarm pivot bolt and swingarm.

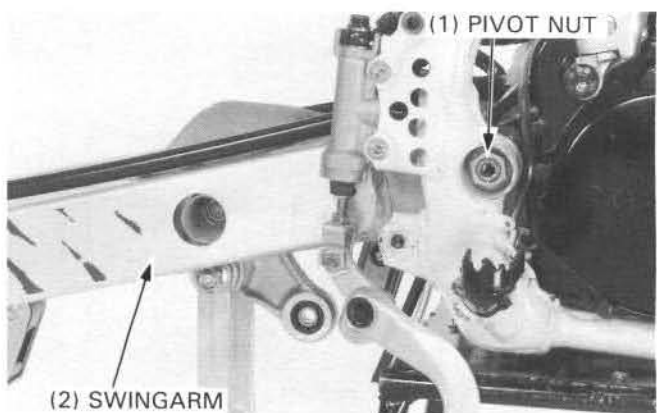
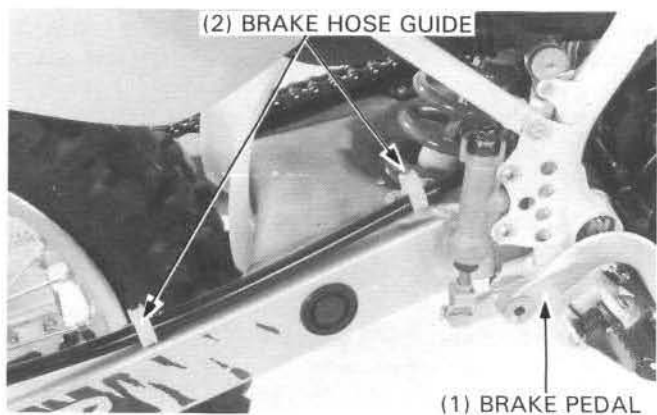

Remove the chain guide and chain slider.

Remove the dust caps, dust seals-and collars.

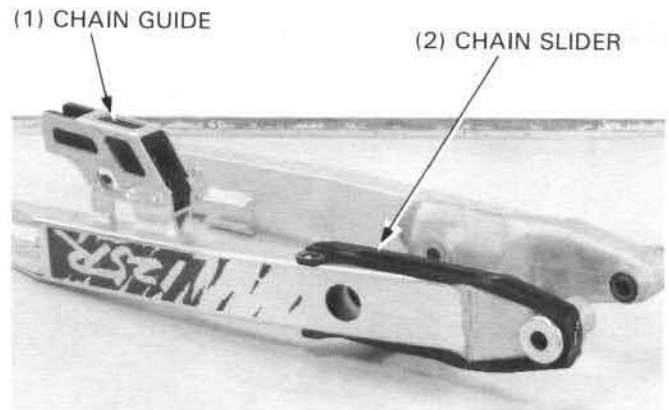

Bearing Replacement

Remove the outside bushings using the screwdriver.
Press out the needle bearings using the following tools.

S. TOOL
Needle bearing driver 07946-MJ00100
Driver head 07946-KM40701

Check the bushings for wear or damage, and replace them if necessary.

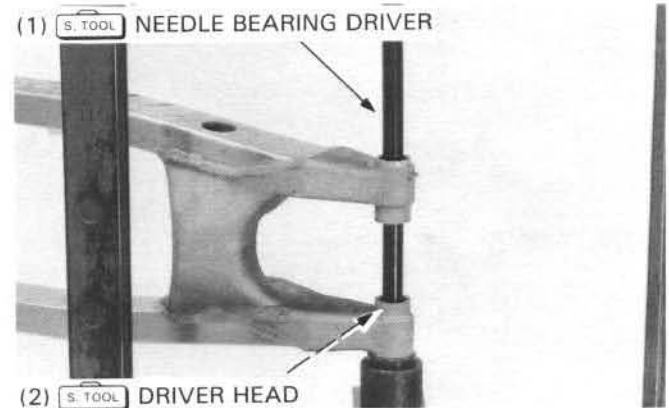

Apply grease to the new needle bearings.

Press the inside bearing into the swingarm pivot.

S. TOOL
Needle bearing driver 07946-MJ00100
Driver head 07946-KM40701

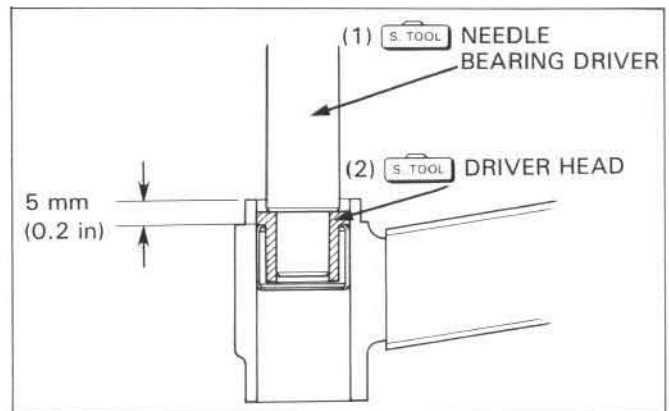

First carefully press the inner needle bearing, then press in the outer bearing and bushing.

NOTE

- Install the bearings with the marks facing out.

S. TOOL
Needle bearing driver 07946-MJ00100
Driver head 07946-KM40701
Attachment, 32 x 35 mm 07746-0010100
Pilot, 22 mm 07746-0041000

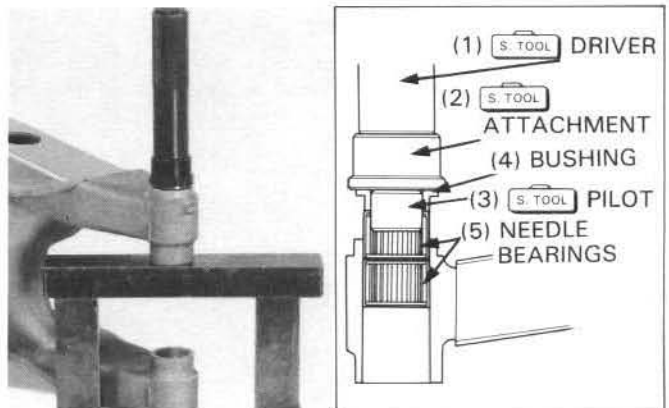

Assembly

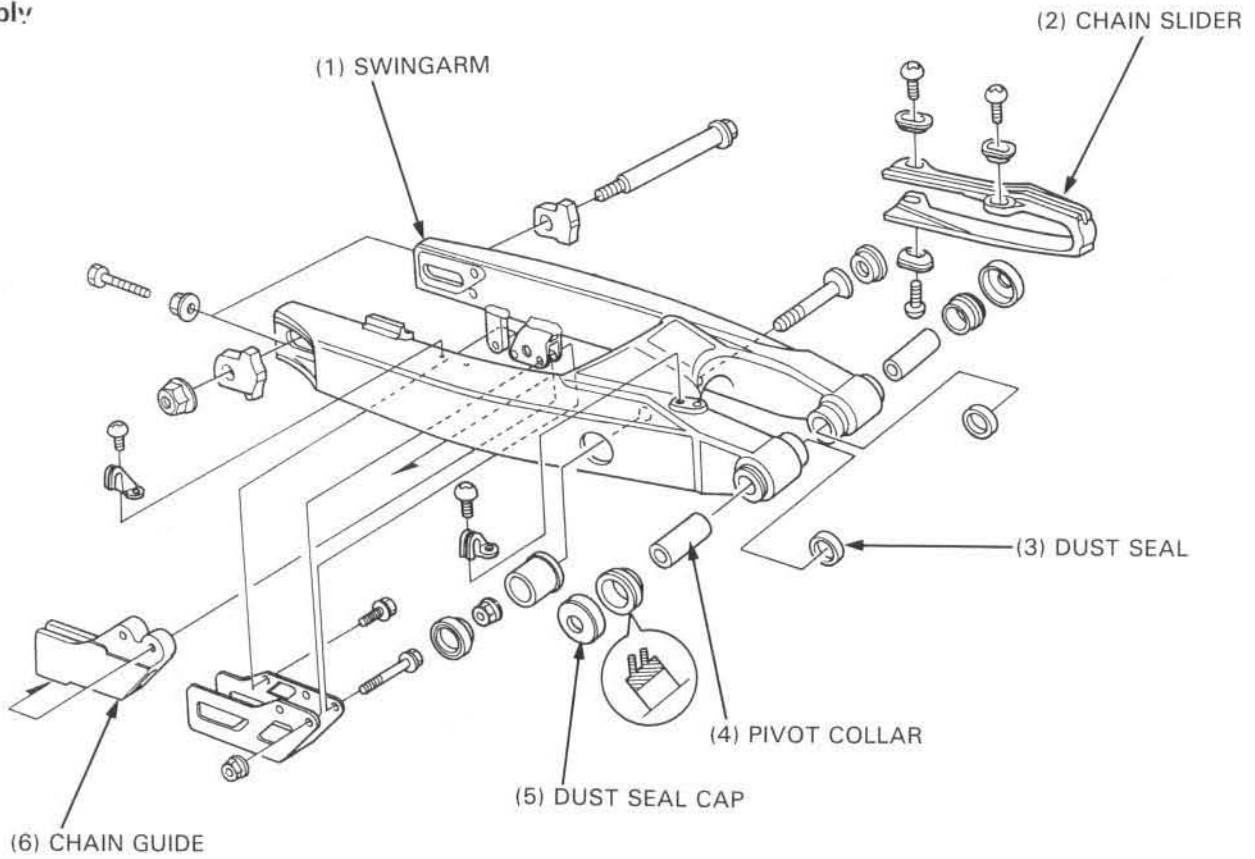

Apply grease to the needle bearing and the inside of the dust seals and collars.

Install the drive chain guide and chain slider.

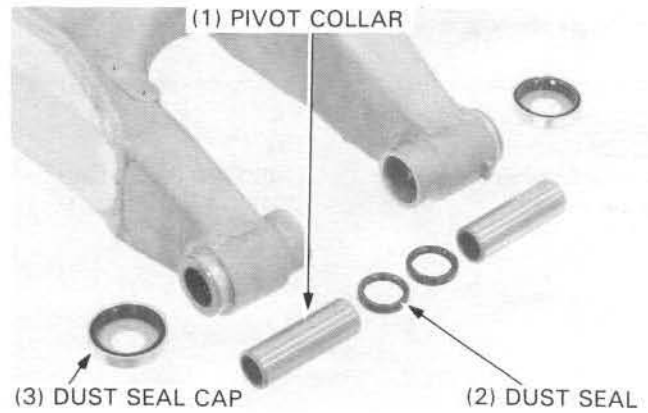

Installation

Install the swingarm onto the frame, and tighten the pivot nut to the specified torque.

Torque: 90 N·m (9.0 kg·m, 65 ft·lb)

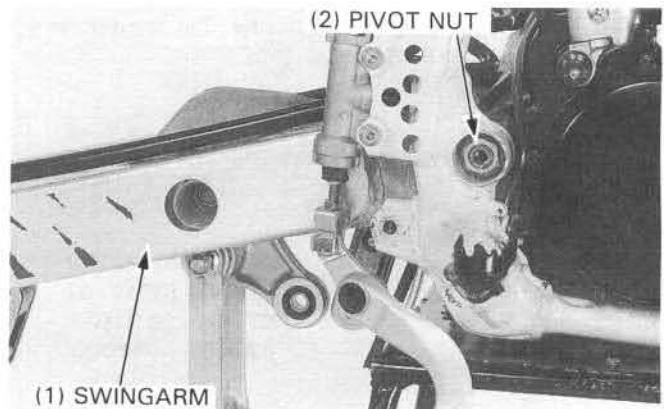

Route the carburetor air bent tube and drain tube.
Route the brake hose and install the brake hose guide.

Install the following:

- Shock linkage (page 12-26)
- Rear wheel (page 12-7)
- Rear brake pedal (page 13-14)
- Drive chain

Adjust the drive chain slack (page 3-10).

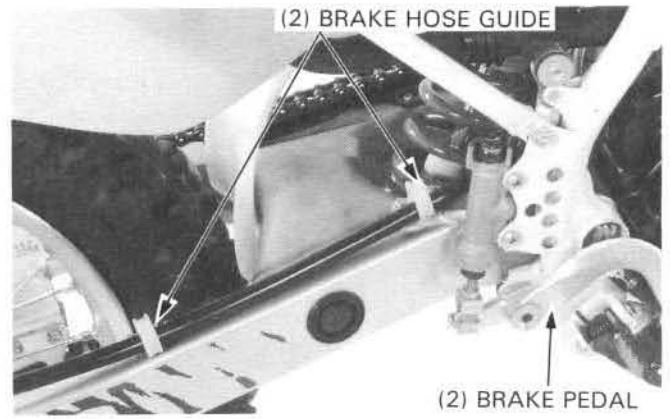

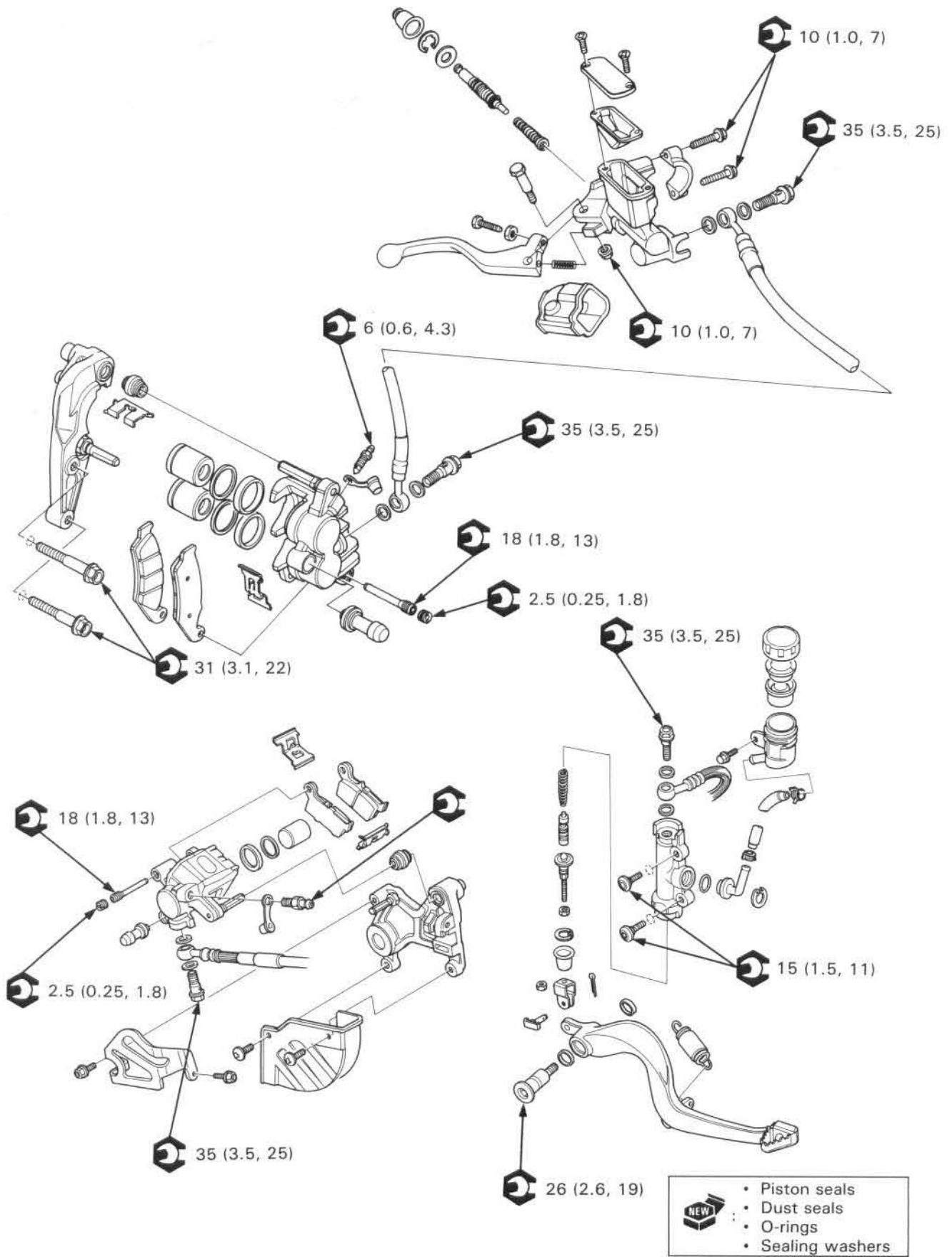

13. Brake System

Service Information	13-1	Rear Master Cylinder	13-8
Troubleshooting	13-2	Front Brake Caliper	13-10
Brake Fluid Replacement/ Air Bleeding	13-3	Rear Brake Caliper	13-12
Brake Pad Replacement	13-5	Rear Brake Pedal	13-14
Front Master Cylinder	13-6		

Service Information

General

Brake dust may contain asbestos fibers.
Never use an air hose or dry brush to clean brake assemblies.

▲ WARNING

- Inhaled asbestos fibers have been found to cause respiratory disease and cancer.

Keep grease off of brake pads and disc.

▲ WARNING

- A contaminated brake disc or pads reduces stopping power. Discard contaminated pads and clean a contaminated disc with Honda Contact/Brake Cleaner or equivalent high quality brake degreasing agent.
- Bleed the hydraulic system if it has been disassembled or if the brake feel spongy.
- Do not allow foreign material to enter the system when filling the reservoir.
- Avoid spilling brake fluid on painted, plastic or rubber parts. Place a rag or shop towel over these parts whenever the system is serviced.

CAUTION

- Spilling fluid on painted, plastic or rubber parts will damage them. Place a clean shop towel over these parts whenever the system is serviced.
KEEP OUT OF REACH OR CHILDREN.
- Always check the brake operation before riding the motorcycle.

Specifications

Unit: mm (in)

Item		Standard	Service Limit
Brake fluid	Front	DOT 3 or 4	—
	Rear	DOT 4	—
Brake disc thickness	Front	3.0 (0.12)	2.5 (0.10)
	Rear	4.5 (0.18)	4.0 (0.16)
Brake disc runout	Front	—	0.15 (0.006)
	Rear	—	0.15 (0.006)
Master cylinder I.D.	Front	11.000—11.043 (0.4330—0.4347)	11.05 (0.435)
	Rear	12.700—12.743 (0.4999—0.5016)	12.76 (0.502)
Master piston O.D.	Front	10.957—10.984 (0.4314—0.4324)	10.84 (0.427)
	Rear	12.657—12.684 (0.4983—0.4993)	12.64 (0.498)
Caliper cylinder I.D.	Front	27.000—27.050 (1.0630—1.0650)	27.06 (1.065)
	Rear	27.000—27.050 (1.0630—1.0650)	27.06 (1.065)
Caliper piston O.D.	Front	26.900—26.950 (1.0590—1.0610)	26.89 (1.059)
	Rear	26.935—26.968 (1.0604—1.0617)	26.89 (1.059)

Brake System

Torque Values

Brake hose banjo bolt	35 N·m (3.5 kg-m, 25 ft-lb)
Brake lever adjuster lock nut	6 N·m (0.6 kg-m, 4.3 ft-lb)
Front brake hose guide	5 N·m (0.5 kg-m, 3.6 ft-lb)
Front master cylinder holder bolt	10 N·m (1.0 kg-m, 7 ft-lb)
Front caliper mounting bolt	31 N·m (3.1 kg-m, 22 ft-lb) Apply a locking agent
Caliper bleeder valve	6 N·m (0.6 kg-m, 4.3 ft-lb)
Rear disc guard mounting screw	7 N·m (0.7 kg-m, 5.1 ft-lb)
Rear master cylinder mounting bolt	15 N·m (1.5 kg-m, 11 ft-lb)
Caliper pin bolt A (front)	23 N·m (2.3 kg-m, 17 ft-lb) Apply a locking agent
(rear)	28 N·m (2.8 kg-m, 20 ft-lb) Apply a locking agent
Caliper pin bolt	13 N·m (1.3 kg-m, 9 ft-lb) Apply a locking agent
Brake caliper pad pin	18 N·m (1.8 kg-m, 13 ft-lb)
Brake caliper pad pin plug	2.5 N·m (0.25 kg-m, 1.8 ft-lb)
Brake pedal pivot bolt	26 N·m (2.6 kg-m, 19 ft-lb)

Troubleshooting

Brake Lever (Pedal) Soft Or Spongy

- Air bubbles in the hydraulic system
- Leaking hydraulic system
- Contaminated brake pads/disc
- Worn caliper piston seal
- Worn master cylinder piston seal
- Worn brake pads/disc
- Contaminated caliper
- Caliper not sliding properly
- Low fluid level
- Clogged fluid passage
- Warped/deformed brake disc
- Sticking/worn caliper piston
- Sticking/worn master cylinder piston
- Contaminated master cylinder
- Bent brake lever

Brake Lever (Pedal) Hard

- Clogged/restricted brake system
- Sticking/worn caliper piston
- Caliper not sliding properly
- Clogged/restricted fluid passage
- Worn caliper piston seal
- Sticking/worn master cylinder piston
- Bent brake lever

Brake Drag

- Contaminated brake pad/disc
- Misaligned wheel
- Worn brake pad/disc
- Warped/deformed brake disc
- Caliper not sliding properly

Brake Fluid Replacement/Air Bleeding

Turn the handlebar so that the front brake reservoir is parallel to the ground. Check the fluid level with the master cylinder or reservoir.

CAUTION

- Avoid spilling fluid on painted, plastic or rubber parts. Place a shop towel over these parts whenever the system is serviced.

Brake Fluid Draining

Connect a bleed hose to the bleed valve. Loosen the caliper bleed valve and pump the brake lever. Stop operating the brake when fluid stops flowing out of the bleed valve.

▲ WARNING

- A contaminated brake disc or pad reduces stopping power. Discard contaminated pads and clean the contaminated disc with a high quality brake degreasing agent.

Brake Fluid Filling/Air Bleeding

CAUTION

- Do not mix different types of fluid since they are not compatible.
- Do not mix brake fluid types and never reuse the contaminated fluid which has been pumped out during brake bleeding, because this will impair the efficiency of the brake system.

Front:

Fill the master cylinder reservoir with DOT 3 or DOT 4 brake fluid from a sealed container to the top of the casting ledge.

Rear:

Fill the reservoir to the upper level line with DOT 4 brake fluid from a sealed container.

Connect the Mityvac Brake Bleeder No.6860 or equivalent to the bleed valve.

NOTE

- Check the fluid level often while bleeding the brakes to prevent air from being pumped into the system.
- When using a brake bleeding tool, follow the manufacturer's operating instruction.

Pump the brake bleeder and loosen the bleed valve. Add fluid when the fluid level in the master cylinder is low to prevent drawing air into the system.

Repeat the above procedures until no air bubbles appear in the plastic hose.

NOTE

- If air is entering the bleeder from around the bleed valve threads, seal the thread with teflon tape.

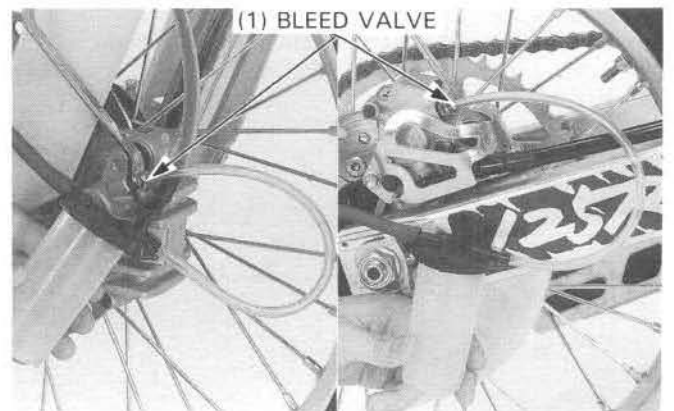
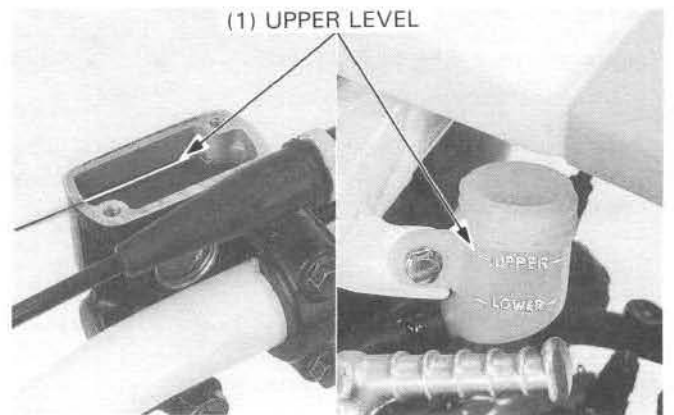
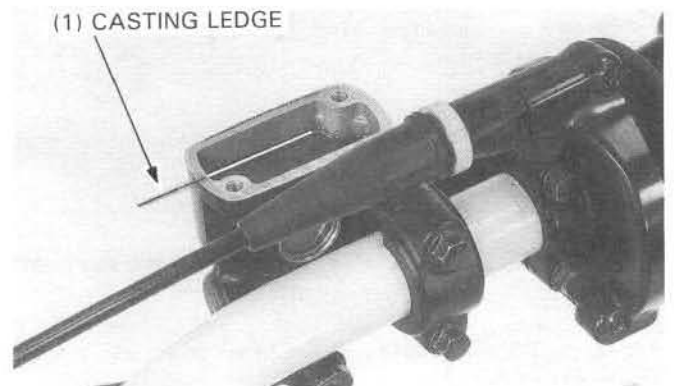
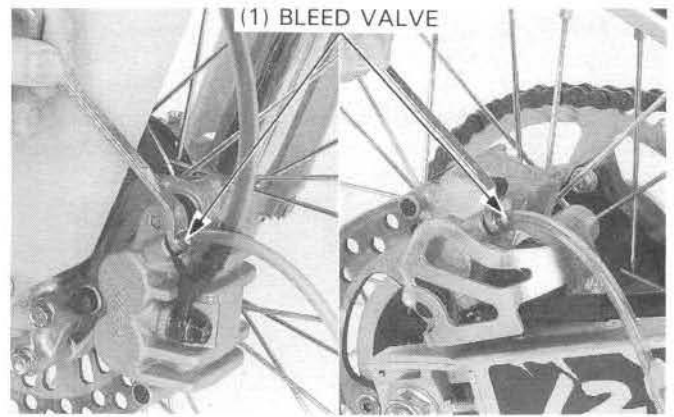

Brake System

If a brake bleeder is not available, perform the following procedure.

Pump up the system pressure with the lever or pedal until there are no air bubbles in the fluid flowing out of the reservoir small hole and lever/pedal resistance is felt.

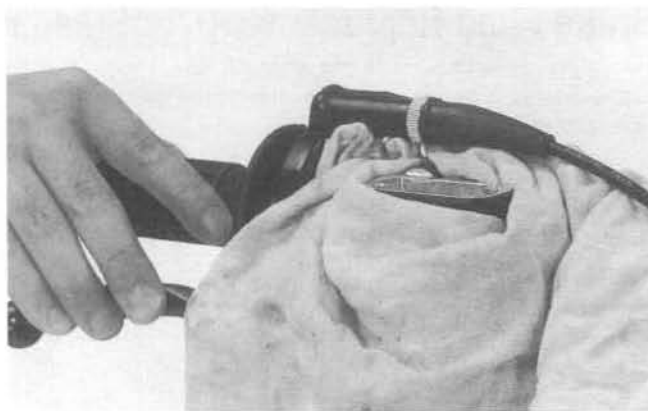

- 1) Operate the brake lever or pedal, then open the bleed valve 1/2 turn and close the valve.

NOTE

- Do not release the brake lever or pedal until the bleed valve has been closed.

- 2) Release the brake lever or pedal slowly and wait several seconds after it reaches the end of its travel.

Repeat step 1 and 2 until bubbles cease to appear in the fluid at the end of the hose.

Tighten the bleed valve to the specified torque.

Torque: 6 N·m (0.6 kg·m, 4.3 ft·lb)

Front:

Fill the master cylinder reservoir with DOT 3 or DOT 4 brake fluid from a sealed container to the top of the casting ledge. Reinstall the diaphragm and master cylinder cover. Tighten the screws securely.

Rear:

Fill the reservoir to the upper level line with DOT 4 brake fluid from a sealed container.

Tighten the rear reservoir cap securely.

⚠ WARNING

- A contaminated brake disc or pad reduces stopping power. Discard contaminated pads and clean the contaminated disc with a high quality brake degreasing agent.

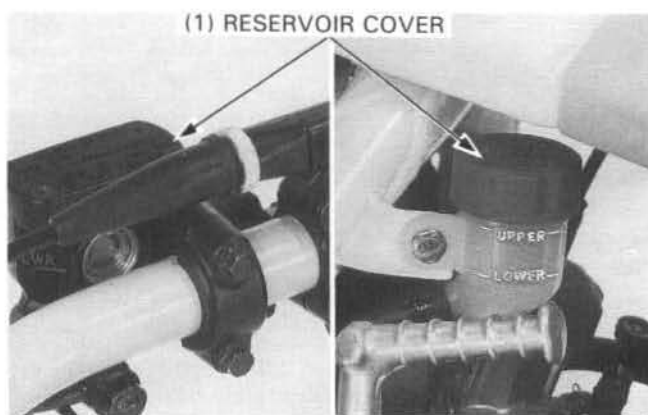
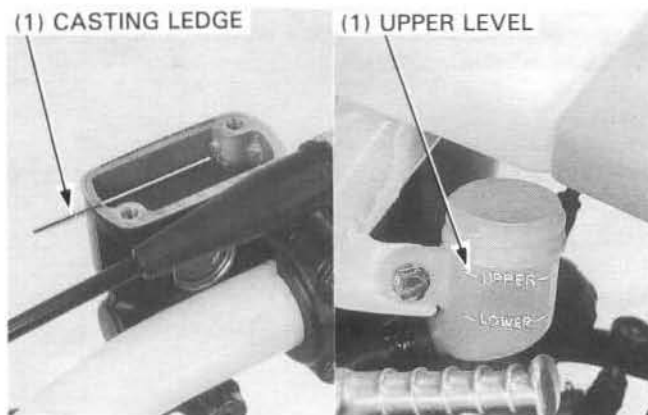
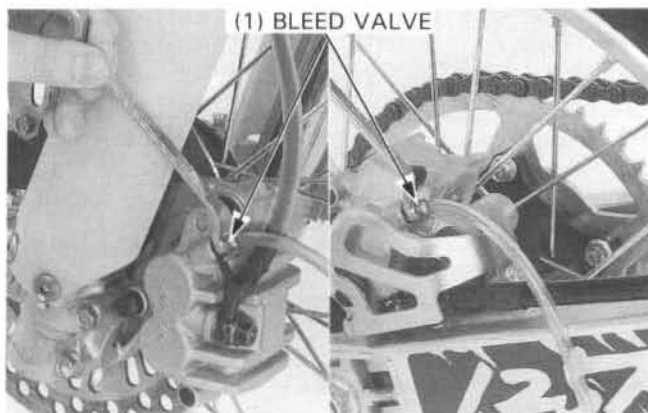

Brake Pad Replacement

▲ WARNING

- A contaminated brake disc or pad reduces stopping power. Discard contaminated pads and clean a contaminated disc with Honda Contact/Brake Cleaner or an equivalent high quality brake degreasing agent.

NOTE

- Always replace the brake pads in pairs to assure even disc pressure.

Remove the pad pin plug and loosen the pad pin.
Pull the pad pin out of the caliper.

Remove the brake pad.

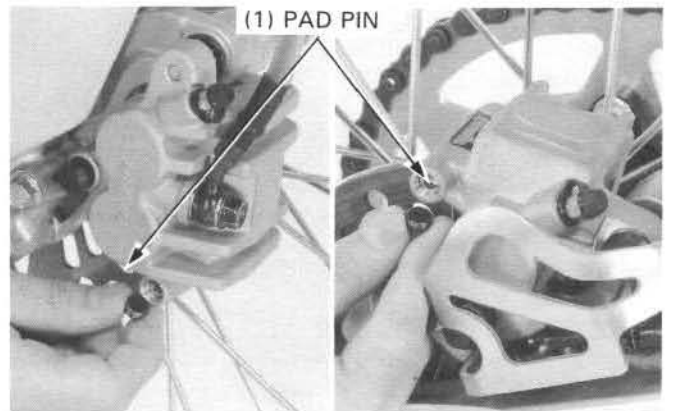
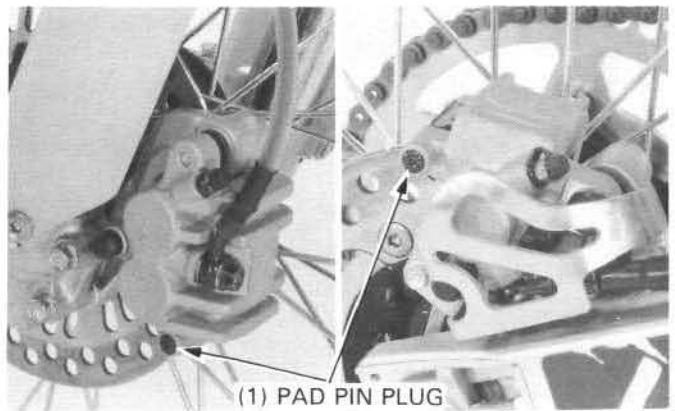

Insert new right side pad and push the caliper piston to allow clearance for that installation of the left side new pad.

Install new left side pad.

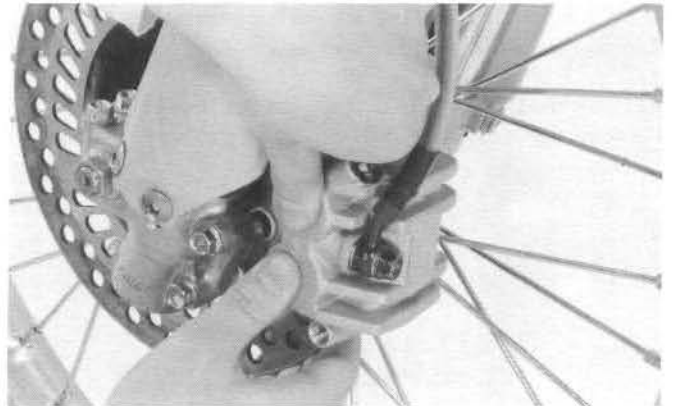

Install the pad pin by pushing the pads against the caliper to depress the pad spring.
Tighten the pad pin to the specified torque.

Torque: 18 N·m (1.8 kg-m, 13 ft-lb)

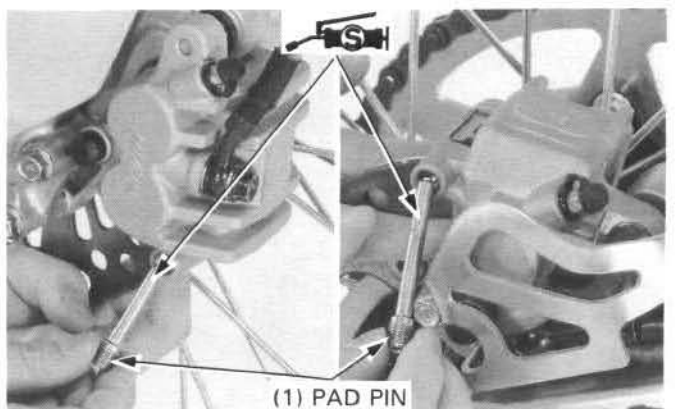

Brake System

Install and tighten the pad pin plug to the specified torque.

Torque: 2.5 N·m (0.25 kg-m, 1.8 ft-lb)

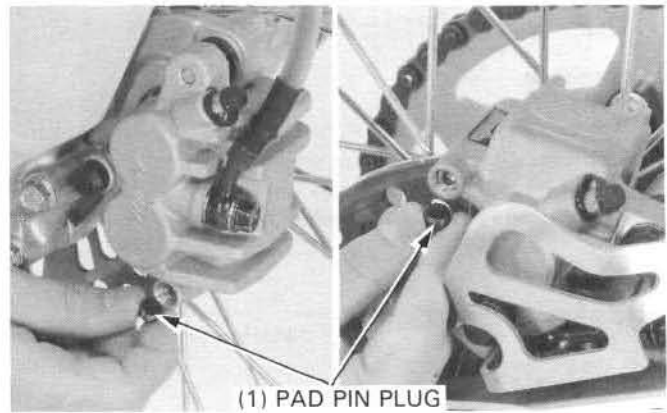

Front Master Cylinder

Removal

CAUTION

- Avoid spilling fluid on painted, plastic or rubber parts. Place a shop towel over these parts whenever the system is serviced.

NOTE

- When removing the brake hose bolt, cover the end of the hose to prevent contamination. Secure the hose to prevent fluid from leaking out.

Drain the front brake hydraulic system (page 13-3).
Remove the pivot nut/bolt and brake lever.

Remove the oil bolt and disconnect the brake hose.
Remove the master cylinder holder and master cylinder.

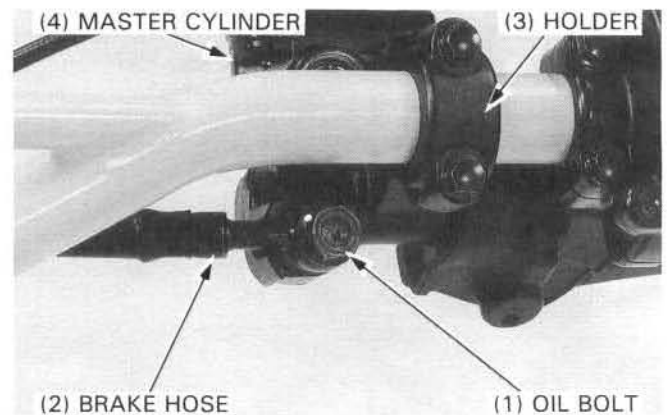
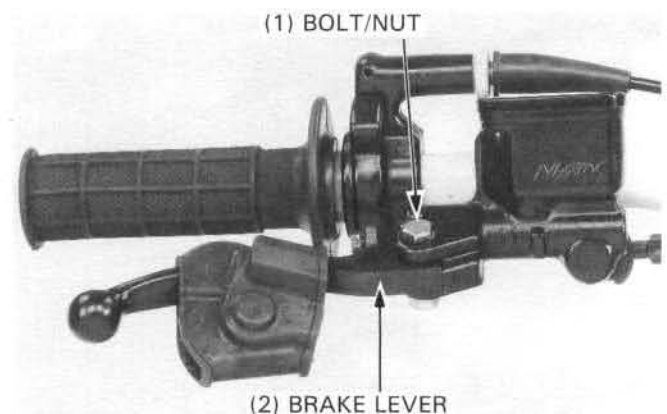

Disassembly

Remove the piston boot, snap ring and washer from the master cylinder body.

 S TOOL

Snap ring pliers

07914-3230001 or
Equivalent commercially
available in U.S.A.

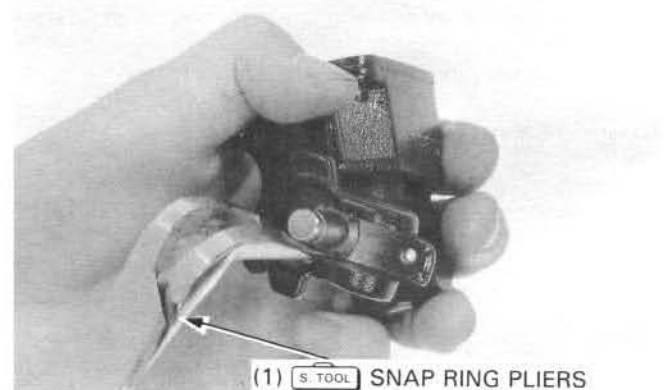

Remove the piston and spring.
Clean the inside of the master cylinder and reservoir with brake fluid.

Inspect the disassembled parts.

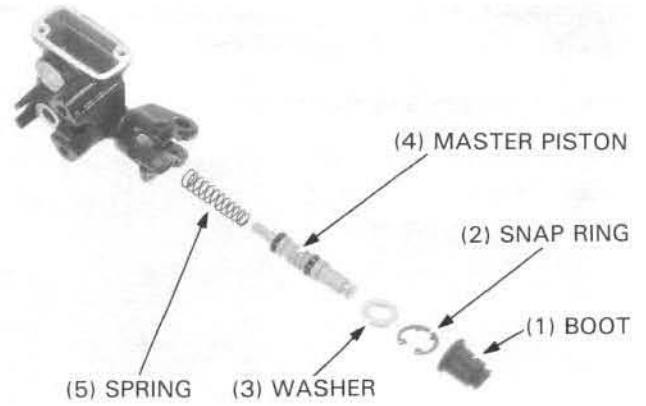

Assembly

CAUTION

- When installing the cups, do not allow the lips to turn inside out. Be certain the snap ring is seated firmly in the groove.

NOTE

- Replace the master cylinder piston, cylinder, spring and washer as a set.

Clean the master cylinder with compressed air.
Assemble the master cylinder.
Dip the piston cups in clean brake fluid before assembly.

Install the washer, snap ring and boot.



Snap ring pliers

07914-3230001 or
Equivalent commercially
available in U.S.A.

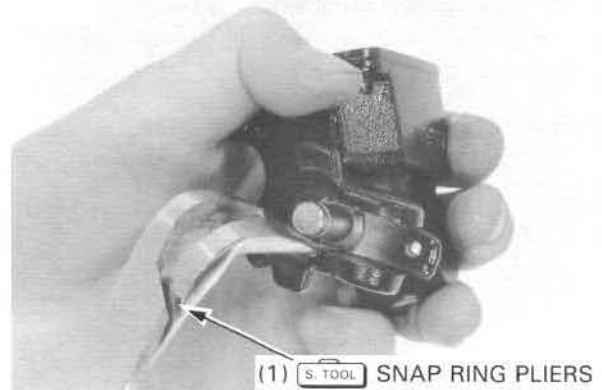
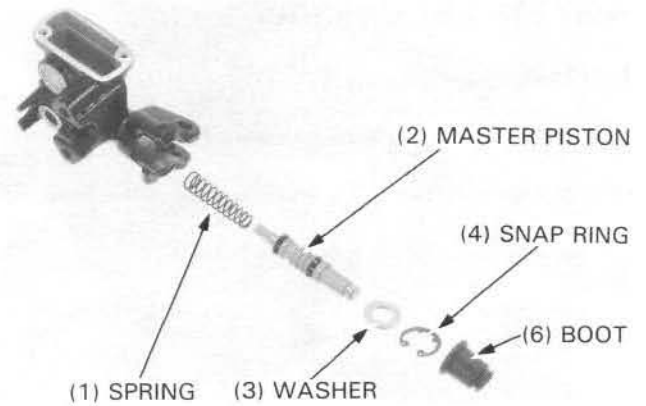

Installation

Place the master cylinder on the handlebar and install the holder and two mounting bolts with holder's "UP" mark facing up.

Align the end of the holder with the punch mark on the handlebar. Torque the upper bolt first, then the lower bolt.

Torque: 10 N·m (1.0 kg-m, 7 ft-lb)

Connect the brake hose eyelet joint with a new sealing washers.
Tighten the oil bolt.

Torque: 35 N·m (3.5 kg-m, 25 ft-lb)

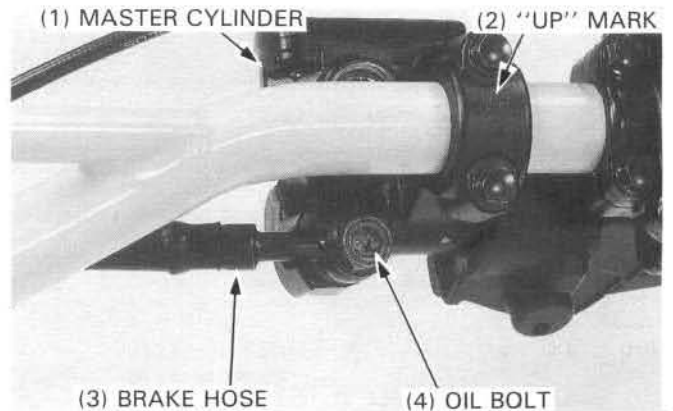

Brake System

Apply silicone grease to the pivot and install the brake lever. Install and tighten the brake lever pivot nut.

Torque: 10 N·m (1.0 kg·m, 7 ft·lb)

Fill the master cylinder to the proper level and bleed the brake system (page 13-3).

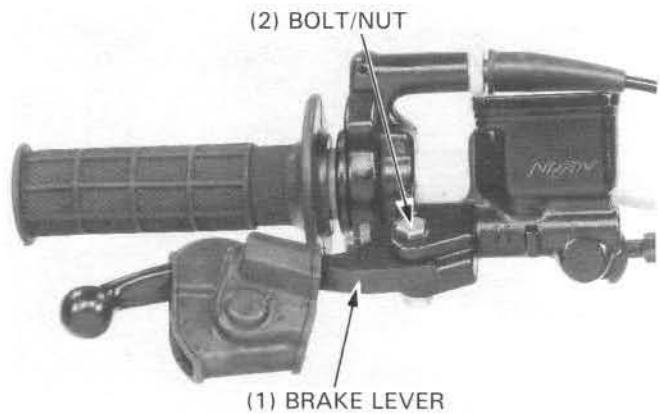

Rear Master Cylinder

Removal

Drain the rear brake hydraulic system (page 13-3).

Remove the brake hose bolt and disconnect the brake hose.

Remove the brake pedal (page 13-14).

Remove the rear master cylinder mounting bolts and rear master cylinder from the frame.

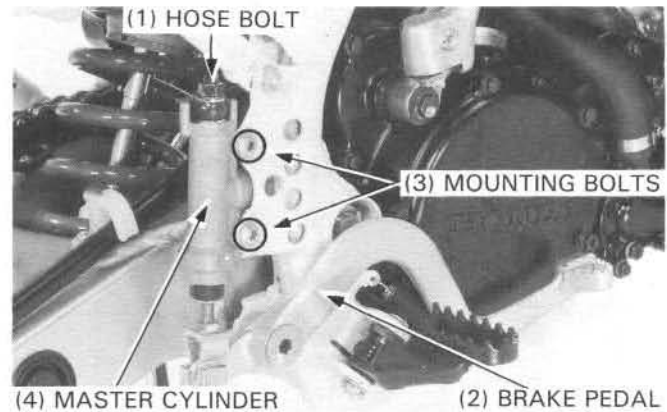

Remove the snap ring and disconnect the reservoir hose joint from the master cylinder.



Snap ring pliers

07914-3230001 or
Equivalent commercially
available in U.S.A.

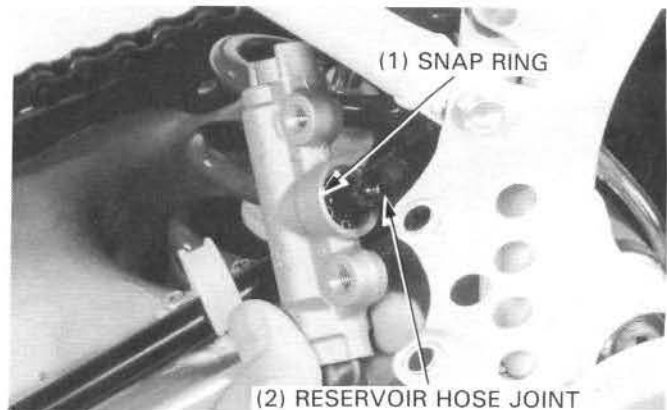

Disassembly

Remove the rubber boot.

Remove the snap ring and push rod from the master cylinder body.

CAUTION

- Be aware that the push rod will pop out when the snap ring is removed.



Snap ring pliers

07914-3230001 or
Equivalent commercially
available in U.S.A.

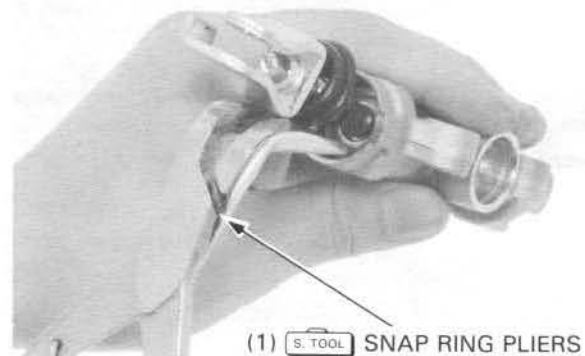

Remove the master piston and spring.

It may be necessary to apply a small amount of air pressure to the fluid outlet to remove the master piston and spring.

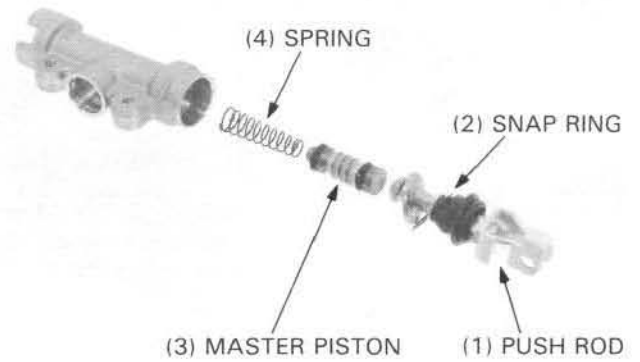

Assembly

CAUTION

- When installing the cups, do not allow the lips to turn inside out. Be certain the snap ring is seated firmly in the groove.

NOTE

- Replace the master cylinder piston, cylinder and spring as a set.

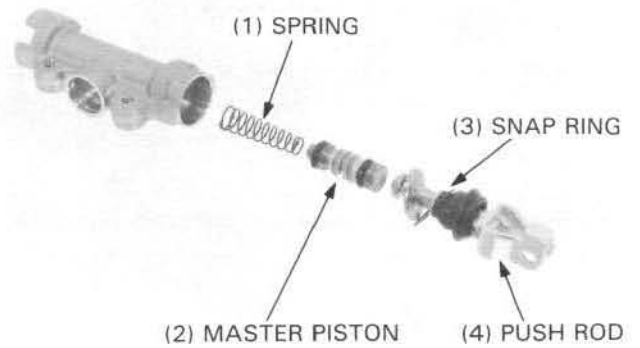

Clean the master cylinder with compressed air.

Dip the piston cups in clean brake fluid before assembly.

Install the spring and master piston together.

Install the push rod and washer into the master cylinder.
Install the snap ring.

S. TOOL

Snap ring pliers

07914-3230001 or
Equivalent commercially
available in U.S.A.

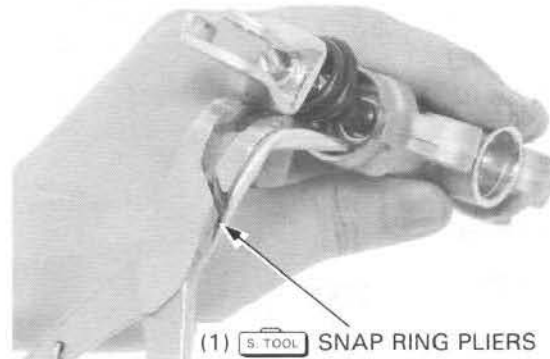

Install the rubber boot.

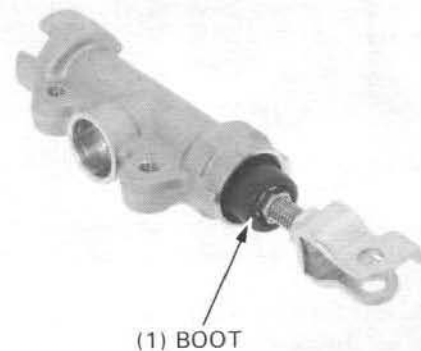

Brake System

Installation

Coat a new O-ring with clean brake fluid and install it in the reservoir hose joint cup. Connect the reservoir hose to the master cylinder with a new snap ring.

5. TOOL

Snap ring pliers

**07914-3230001 or
Equivalent commercially
available in U.S.A.**

Attach the master cylinder to the frame.

Connect the rear brake pedal to the master cylinder push rod and install the brake pedal (page 13-14).

Apply Honda Anaerobic Thread Lock or equivalent to the rear master cylinder mounting bolt threads.

Install and tighten the rear master cylinder mounting bolts to the specified torque.

Torque: 15 N·m (1.5 kg·m, 11 ft·lb)

Connect the rear brake hose eyelet joint with the hose bolt and two new sealing washers.

CAUTION

- Align the eyelet joint with the notch in the master cylinder first, then tighten the bolt.
- After installing the brake hose to the master cylinder, make sure it does not interfere with the movement of the shock absorber.

Tighten the brake oil bolt to the specified torque.

Torque: 35 N·m (3.5 kg·m, 25 ft·lb)

Fill the brake system with DOT 4 brake fluid from a sealed container and bleed the system of air (page 13-3).

Front Brake Caliper

Removal

CAUTION

- Avoid spilling fluid on painted, plastic or rubber parts. Place a shop towel over these parts whenever the system is serviced.

Drain the front brake fluid from the hydraulic system.

Remove the brake pads (page 13-5).

Place a clean container under the caliper and remove the brake hose bolt, sealing washer and eyelet joint from the caliper.

Remove the brake caliper bracket bolt, then remove the brake caliper and bracket as an assembly.

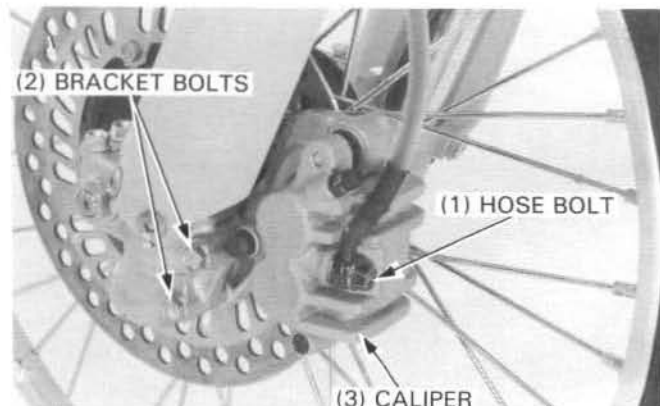
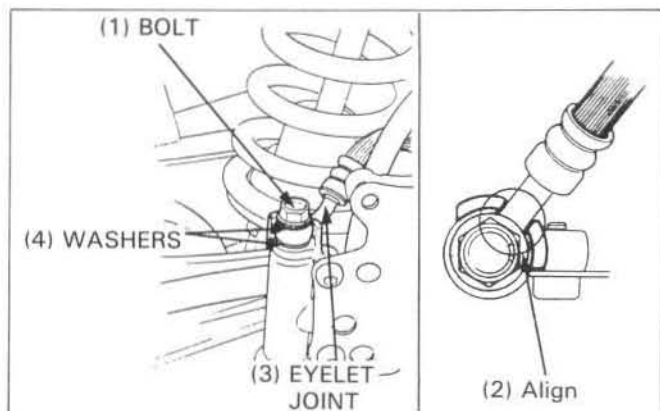
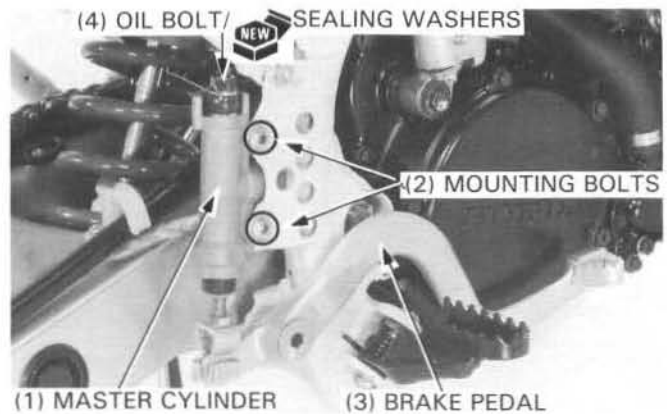
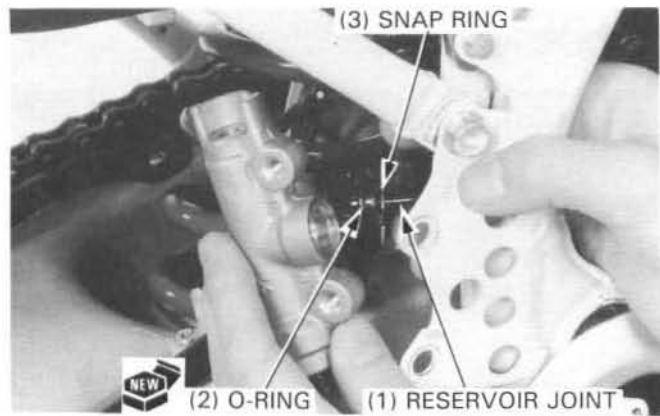

Desassembly

Remove the following:

- Caliper bracket
- Brake pad retainer
- Pad spring
- Caliper pin boot
- Bracket pin boot
- Pistons from cylinder

If necessary, lightly apply compressed air to the caliper fluid inlet to get the piston out.

Place a shop rag under the caliper to cushion the piston when it is expelled.

Use the air in short spurts.

▲ WARNING

- Do not bring the air nozzle too close to the inlet or the pistons may be forced out with excessive force that could cause injury.

Examine the pistons and caliper cylinders for scoring, scratches or other damage.

Replace if necessary.

(1) BRACKET

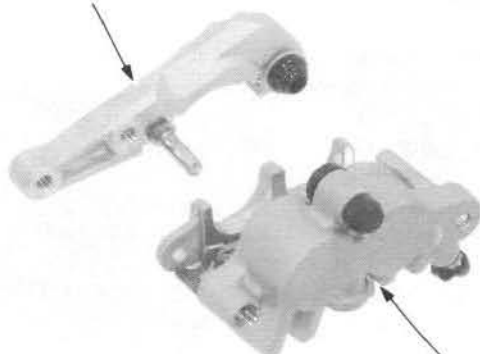

(2) CALIPER

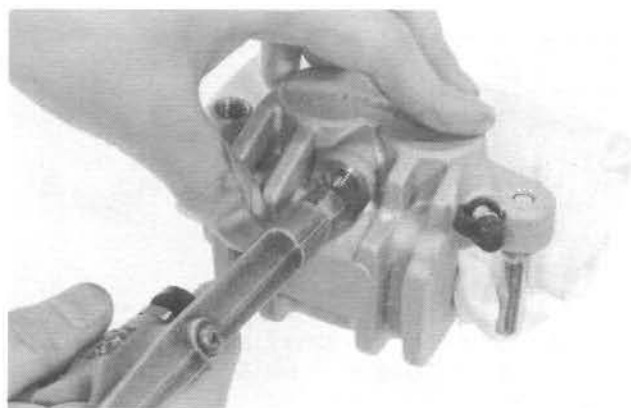

Assembly

Coat the new oil and piston seals with clean brake fluid and install them in the seal grooves of the caliper.

Lubricate the caliper cylinders and pistons with clean brake fluid and install the pistons into the caliper cylinders with the closed end of the piston facing the pad side.

NEW (4) PISTON SEALS (1) BOOT

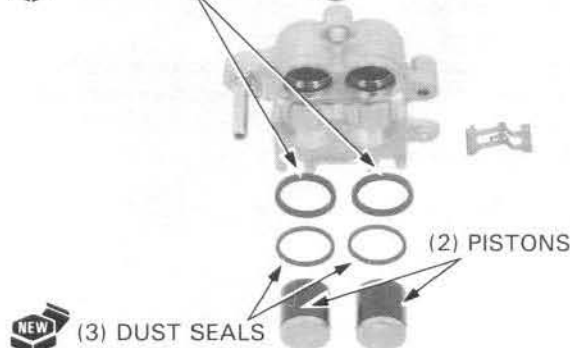

NEW (3) DUST SEALS

Apply silicone grease to the pivot boots and install them making sure that they are seated in the caliper and bracket grooves properly.

Coat the caliper and bracket pins with silicone grease.

Install the pad retainer on the caliper bracket. Install the pad spring on the caliper.

Assemble the caliper and bracket.

(2) BRACKET

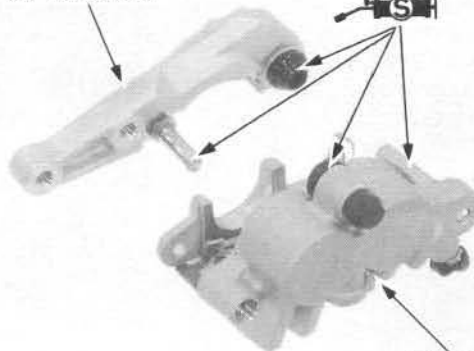

(1) CALIPER

Brake System

Installation

Apply Honda Anaerobic Thread Lock or equivalent to the caliper mounting bolt threads.

Install the caliper and bracket assembly on the fork leg and tighten the bracket bolts.

Torque: 31 N·m (3.1 kg-m, 22 ft-lb)

Connect the brake hose eyelet joint with two new sealing washers, then tighten the oil bolt.

Torque: 35 N·m (3.5 kg-m, 25 ft-lb)

Fill the master cylinder with DOT 4 brake fluid from a sealed container and bleed any air from the front brake system (page 13-3).

Install the brake pads (page 13-5).

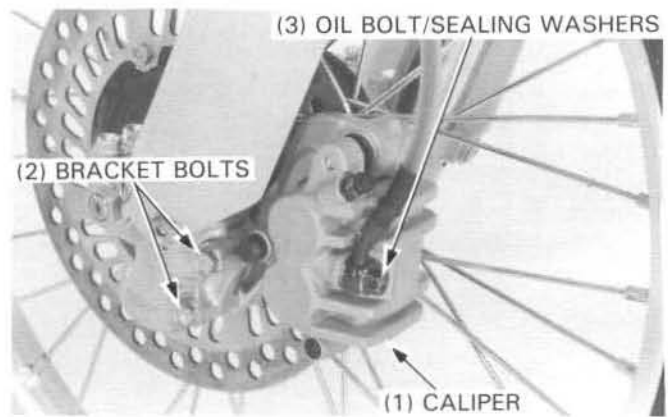

Rear Brake Caliper

Removal

CAUTION

- Avoid spilling fluid on painted, plastic or rubber parts. Place a shop towel over these parts whenever the system is serviced.

Drain the rear brake fluid from the hydraulic system.
Remove the rear wheel (page 12-3).
Remove the brake pads (page 13-5).

Place a clean container under the caliper and remove the brake hose bolt, sealing washer and eyelet joint from the caliper.

Slide the brake caliper backward and pull it off of the swingarm.

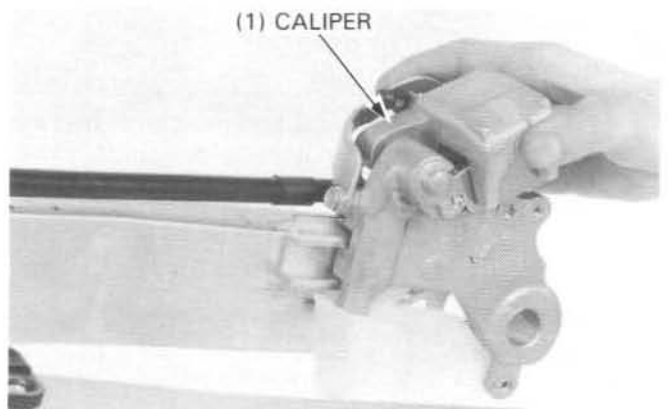
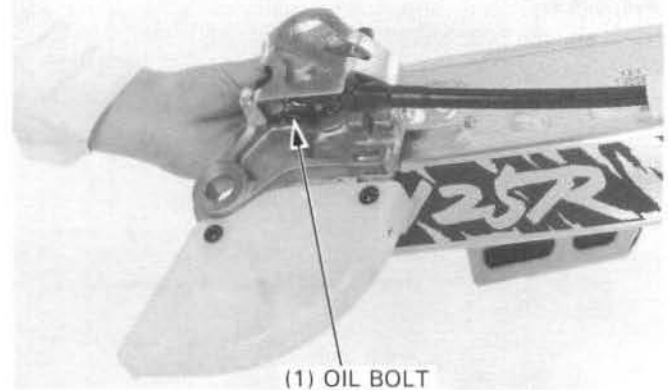

Disassembly

Remove the following:

- Caliper guard plate
- Caliper bracket
- Brake pad retainer
- Pad spring
- Caliper pin boot
- Bracket pin boot
- Piston from cylinder

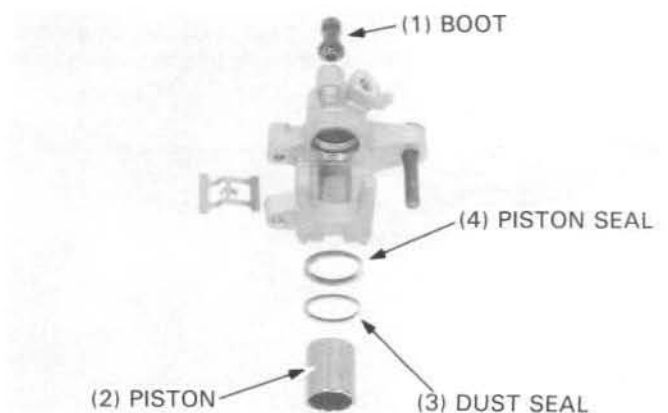

If necessary, lightly apply compressed air to the caliper fluid inlet to get the piston out.
 Place a shop rag under the caliper to cushion the piston when it is expelled.
 Use the air in short spurts.

WARNING

- Do not bring the air nozzle too close to the inlet or the piston may be forced out with excessive force that could cause injury.

Examine the piston and caliper cylinder for scoring, scratches or other damage.
 Replace if necessary.

Assembly

Coat the new dust seal and piston seal with clean brake fluid and install them in the seal grooves of the caliper.

Lubricate the caliper cylinder and piston with clean brake fluid and install the piston into the caliper cylinder with the open end of the piston facing the brake pad.

Apply silicone grease to the pivot boots and install them making sure that they are seated in the caliper and bracket grooves properly.

Coat the caliper caliper and bracket pins with silicone grease.

Install the pad retainer on the caliper bracket.
 Install the pad spring on the caliper.

Assemble the caliper and bracket.

Install the disc guard with two screws and tighten them to the specified torque.

Torque: 7 N·m (0.7 kg-m, 5.1 ft-lb)

Connect the brake hose eyelet joint to the caliper with two new sealing washers.
 Tighten the oil bolt to the specified torque.

Torque: 35 N·m (3.5 kg-m, 25 ft-lb)

Install the rear brake caliper onto the swingarm slide rail.
 Install the following:

- Caliper guard plate
- Rear wheel (page 12-7)
- Rear brake pads (page 13-5)

Fill the master cylinder with DOT 4 brake fluid from a sealed container and bleed the any air from the rear brake system (page 13-3).

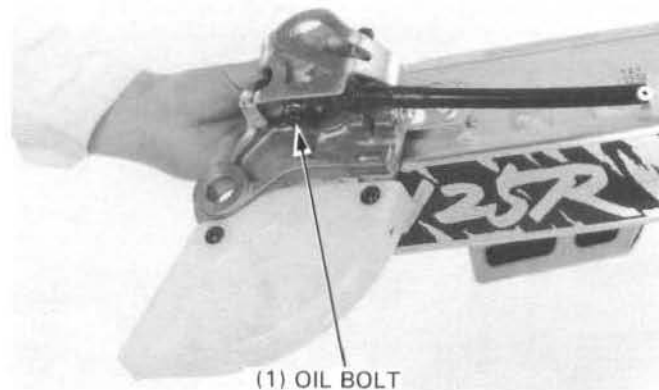
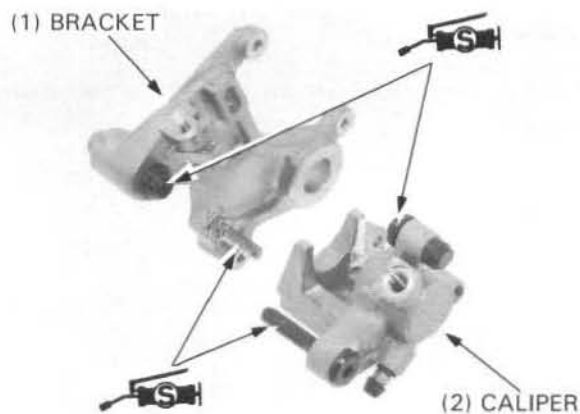
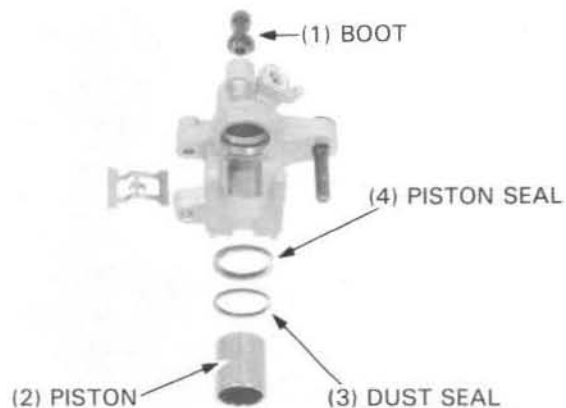
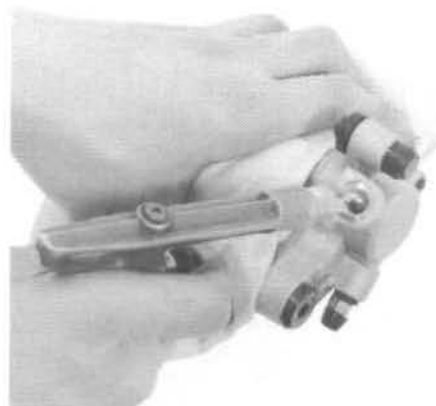

Rear Brake Pedal

Removal

Remove the rear brake pedal pivot bolt and return spring.

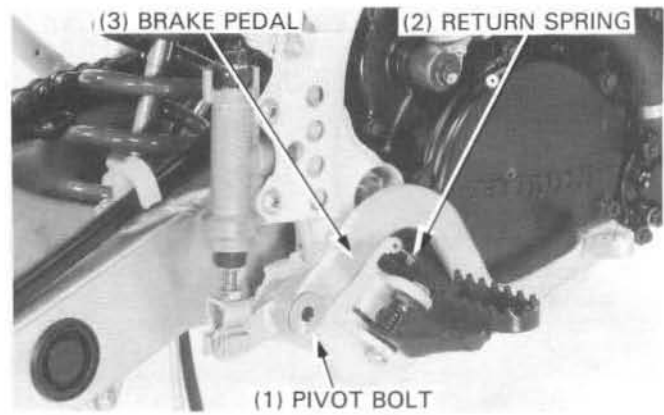

Remove the cotter pin and joint pin.
Remove the brake pedal.

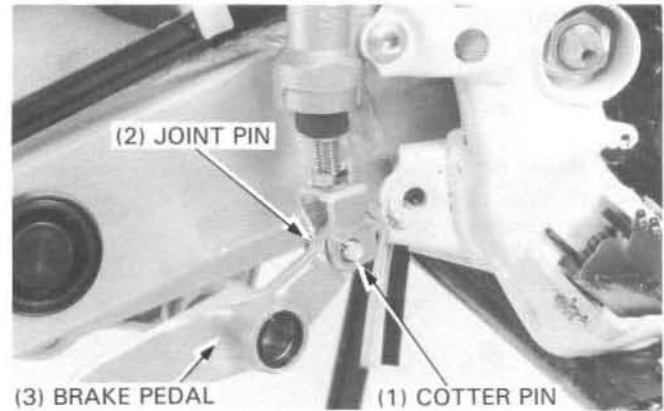

Installation

Install the brake pedal and joint pin and secure them with a new cotter pin.

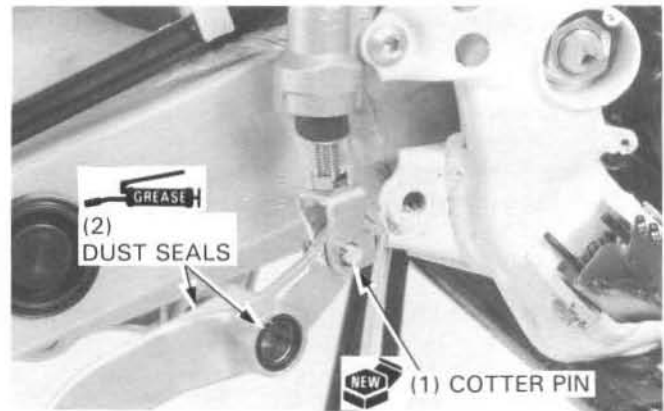

Apply grease to the sliding surface of the pivot bolt and dust seals.

Install the dust seals into the brake pedal pivot.

Install and tighten the pivot bolt to the specified torque.

Torque: 26 N·m (2.6 kg·m, 19 ft·lb)

Install the return spring.

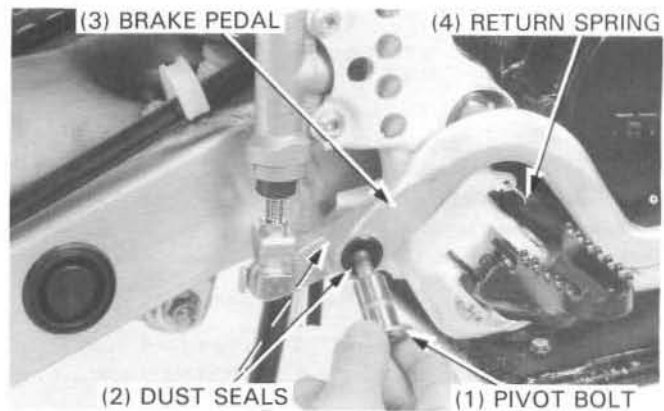

MEMO

RIDE RED

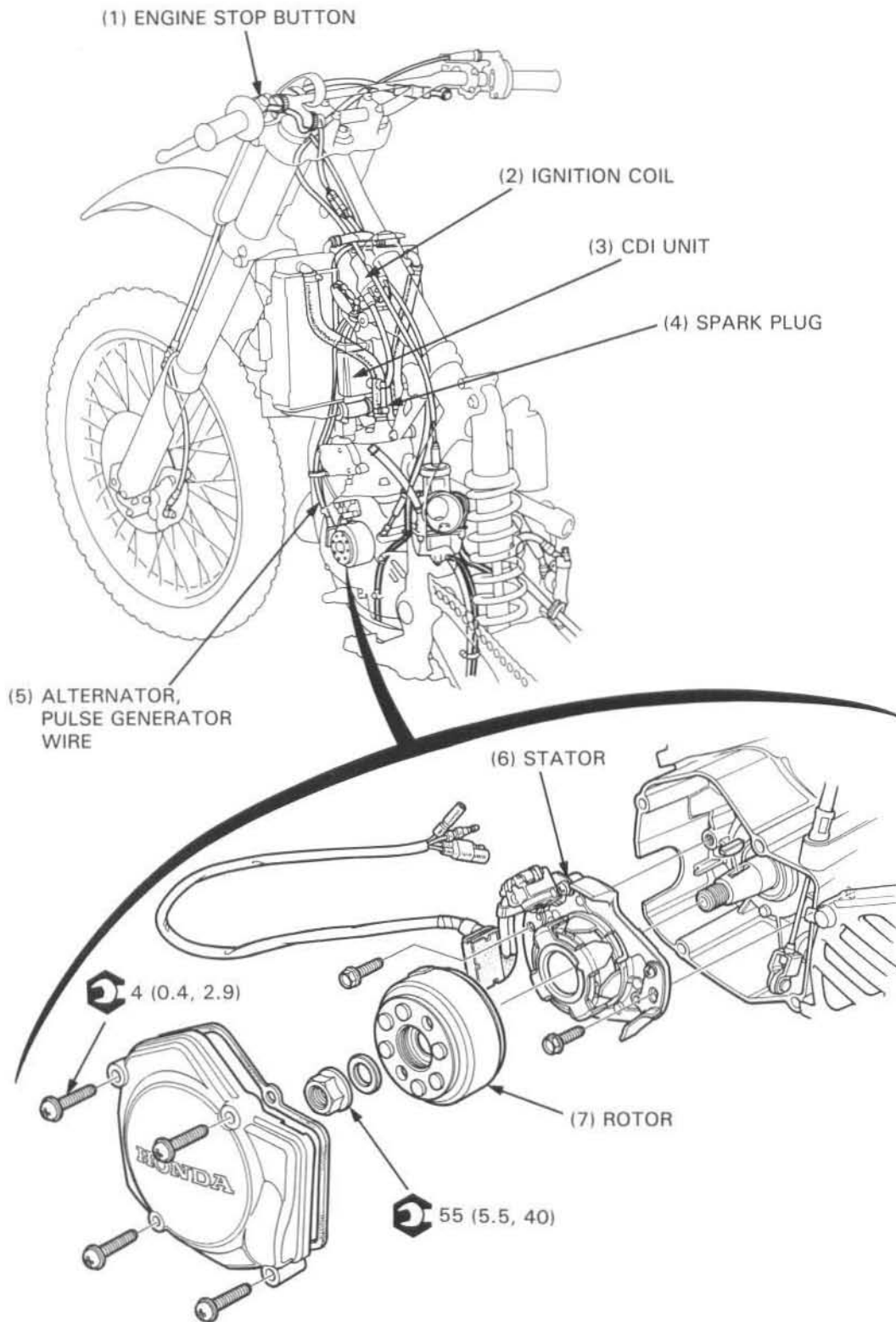

14. Ignition System/Alternator

Service Information	14-1	Ignition coil	14-4
Troubleshooting	14-2	Alternator	14-5
CDI Unit	14-3	Ignition Timing	14-8

Service Information

General

▲ WARNING

- If the engine must be running to do some work, make sure the area is well-ventilated. Never run the engine in an enclosed area. The exhaust contains poisonous carbon monoxide gas that may cause loss of consciousness and lead to death.
- The CDI unit may be damaged if dropped. Also, if the connector is disconnected when current is present, the excessive voltage may damage the unit.
- Ignition timing cannot be adjusted since the CDI unit is non-adjustable. If ignition timing is incorrect, check the system components and replace any faulty parts.
- A faulty ignition system is often related to poorly connected or corroded connectors. Check those connections before proceeding.
- Use a spark plug of the correct heat range. Using a spark plug with an incorrect heat range can damage the engine.
- Replace the pulse generator, exciter coil and stator base as a set.

Specifications

Item		Standard	
Spark plug	Standard	CHAMPION QN84	
		NGK BR9EG	
		NIPPONDENSO W27ESR-V	
	Optional	CHAMPION QN59G	
		NGK BR9EV	
		NIPPONDENSO W27ESR-G	
Spark plug gap		0.5–0.6 mm (0.020–0.024 in)	
Ignition timing "F" mark		30 ± 2° /5,000 rpm	
Ignition coil resistance (At 20°C/68°F)	Primary	0.4–0.6 Ω	
	Secondary	with plug cap	14–23 kΩ
		without plug cap	10–16 kΩ
Alternator exciter coil resistance (At 20°C/68°F)		20–140 Ω	
Pulse generator resistance (At 20°C/68°F)		180–280 Ω	

Torque Values

Alternator cover screw	4 N·m (0.4 kg-m, 2.9 ft-lb)
Flywheel nut	55 N·m (5.5 kg-m, 40 ft-lb)

Tools

Common	
Flywheel puller	07733–0010000
Universal holder	07725–0030000 or equivalent commercially available in U.S.A.

CDI Unit

System Inspection

NOTE

- The CDI unit is semi-conductorized component which includes ignition timing advance, retard system and other calculating circuits. It may be difficult to check the CDI unit by itself. Therefore, testing is done by process of eliminating other causes.

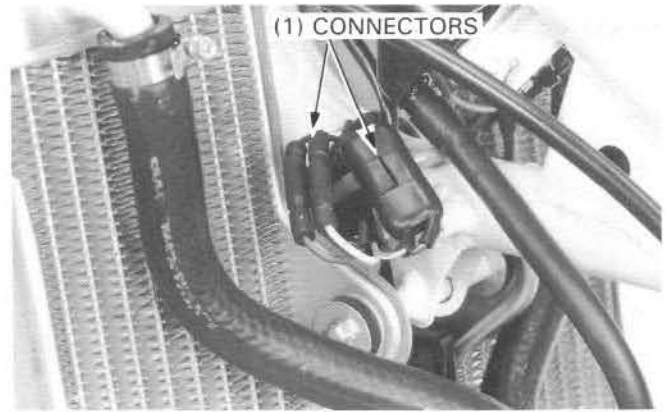

Remove the seat and fuel tank (page 2-2).
Disconnect the CDI unit connectors.

In case of the ignition timing is out of specification or poor or no spark at the plug, check the items below.

- Spark plug
- Connection of all connectors
- Engine stop switch
- Ignition coil
- Alternator excitor coil
- Pulse generator

If all are OK, replace the CDI unit and recheck.

Measure the data between the connector terminals using the following chart.

Item	Terminals	Standard (20°C/68°F)
Ignition primary coil	Black/Yellow and Green	0.4–0.6 Ω
Pulse generator	Blue/Yellow and Green/White	180–280 Ω
Alternator excitor coil	White and Blue	40–140 Ω
Engine stop button	Black/Yellow and Green	<ul style="list-style-type: none"> • Continuity with the stop button pressed • No continuity with the stop button released

Removal/Installation

Drain the radiator coolant (page 5-3).
Remove the seat and fuel tank (page 2-2, 2-3).

Remove the two left radiator mounting bolts and disconnect the lower radiator joint hose.
Swing the left radiator forward.

Disconnect the CDI unit connectors.

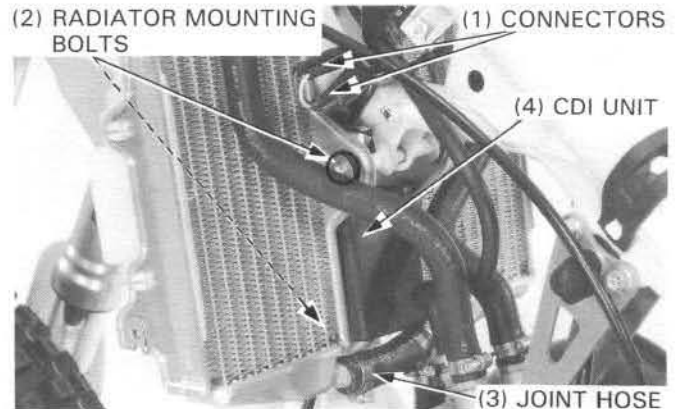

Ignition System/Alternator

Remove the CDI unit, pulling its rubber suspension out of the stay and pin.

Installation is in the reverse order of removal.

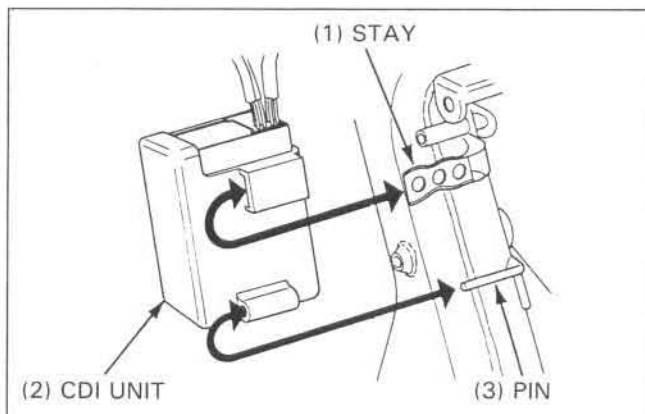

Ignition Coil

Inspection

Remove the seat and fuel tank (page 2-2).

Disconnect the Black/Yellow and Green wires of the ignition coil.

Measure the primary coil resistance of the ignition coil.

Standard: 0.4–0.6 Ω (20°C/68°F)



Disconnect the spark plug cap from the plug and measure the secondary resistance between the plug cap and Green terminal.

Standard: 14–23 k Ω (20°C/68°F)

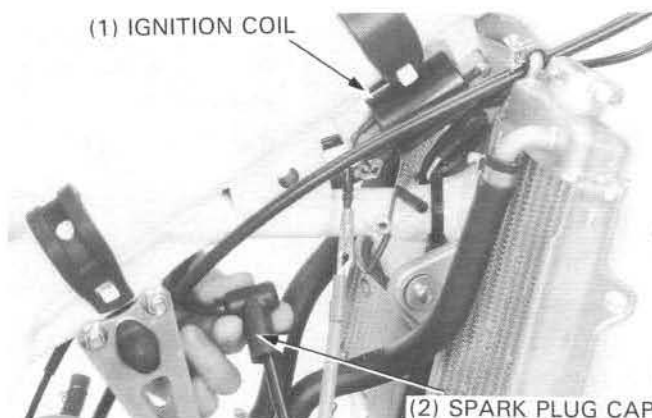

If the resistance is out of range, remove the spark plug cap and measure the secondary coil resistance between the spark plug wire and Green terminal.

Standard: 10–16 k Ω (20°C/68°F)

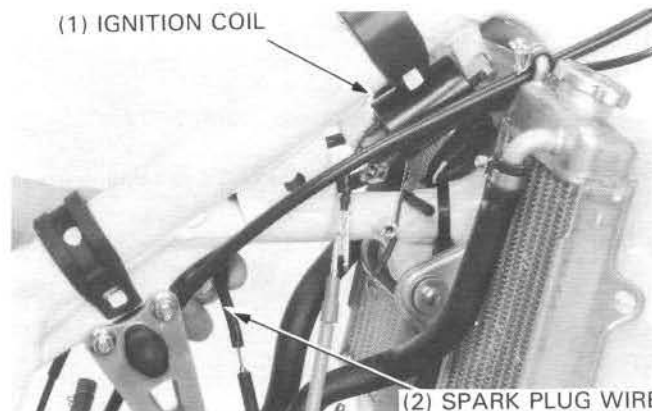

Removal/Installation

Remove the seat and fuel tank (page 2-2).
Remove the spark plug cap from the spark plug.
Disconnect the Black/Yellow and Green wire connector.

Remove the bolts and ignition coil.

Installation is in the reverse order of removal.

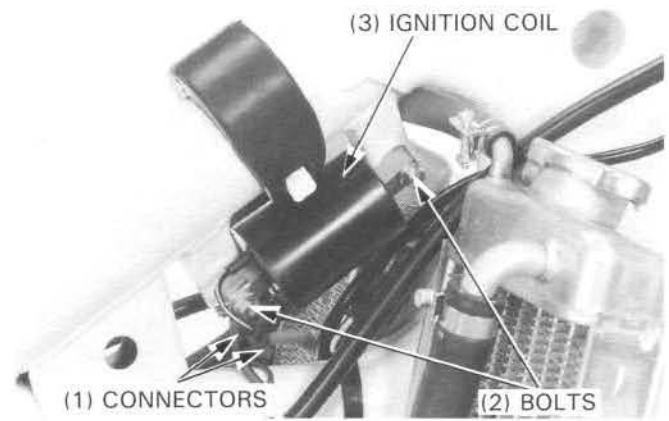

Alternator

Pulse Generator Inspection

Remove the seat and fuel tank (page 2-2).
Disconnect the pulse generator 2P connector.

Measure the resistance between the Blue/Yellow and Green/White terminals.

Standard: 180—280 Ω (20°C/68°F)

If the resistance out of the specification, replace the stator as an assembly.

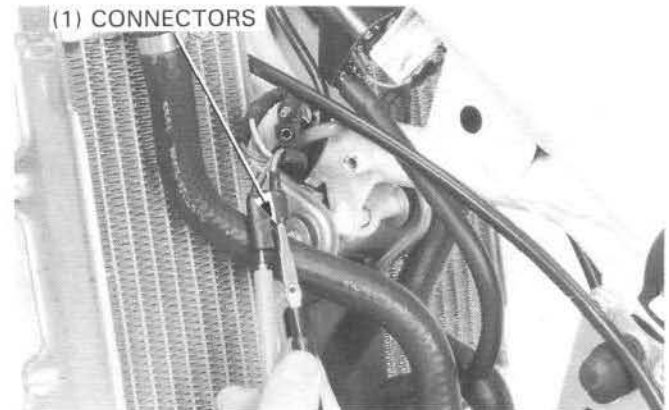

Excitor Coil Inspection

Remove the seat and fuel tank (page 2-2).
Disconnect the excitor 2P connector from the CDI unit.

Measure the resistance between the Blue and White terminals.

Standard: 20—140 Ω (20°C/68°F)

If the resistance out of the specification, replace the stator as an assembly.

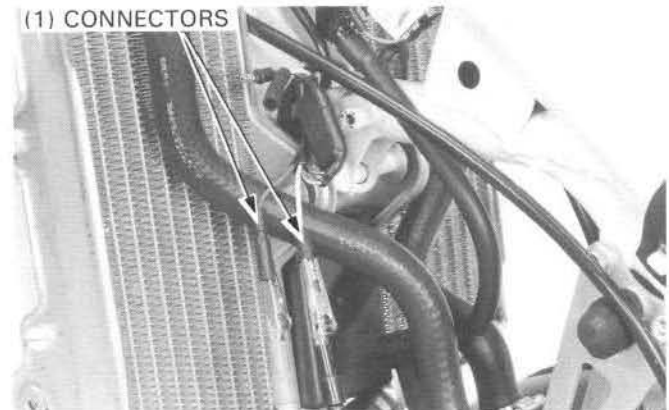

Removal

Remove the seat and fuel tank (page 2-2).
Disconnect the pulse generator and alternator connectors and wire clamp.

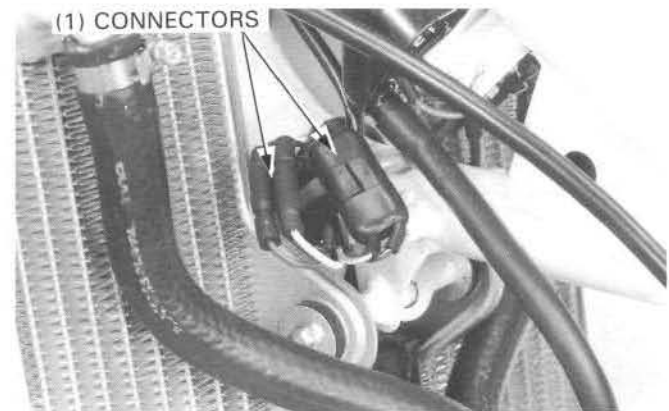

Ignition System/Alternator

Remove the screws and alternator cover.

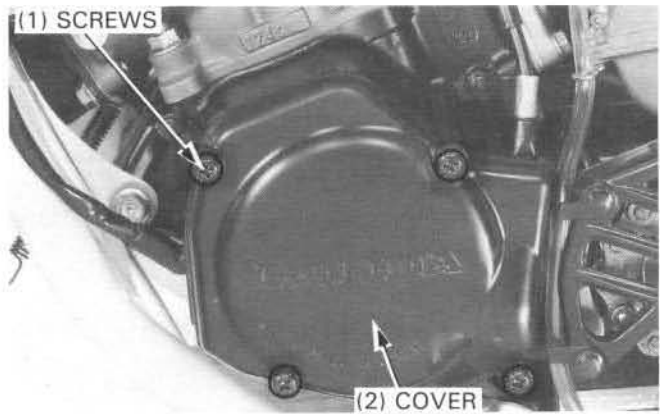

Hold the flywheel with the universal holder and remove the nut.

 S TOOL

Universal holder

07725-0030000 or
Equivalent commercially
available in U.S.A.

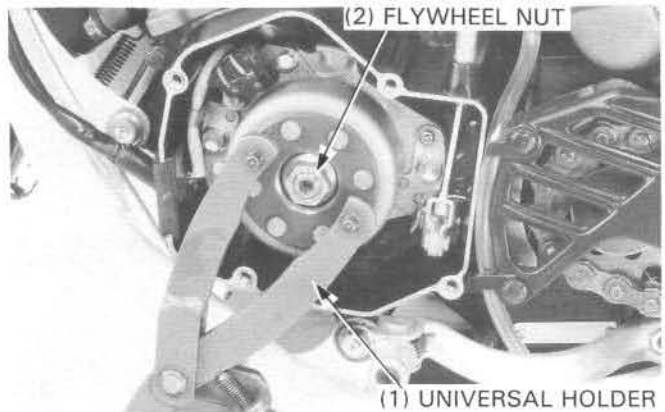

Remove the flywheel using the flywheel puller.

 S TOOL

Flywheel puller

07733-0010000

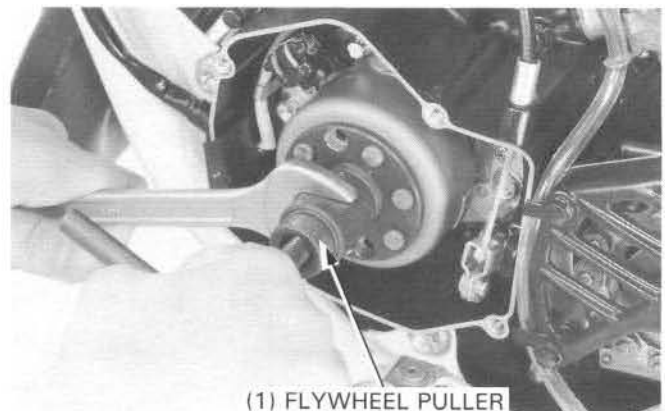

Remove the stator mounting bolts, then remove the stator.

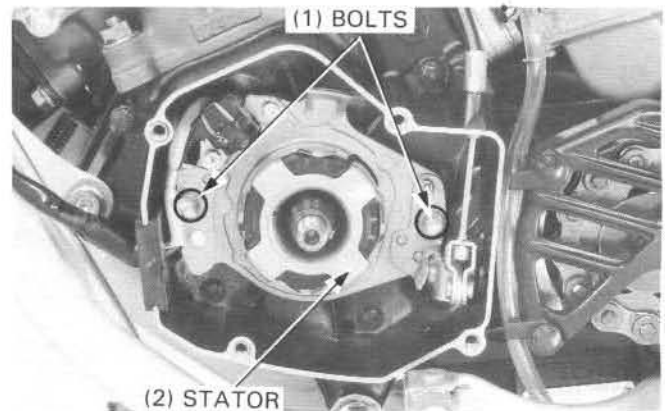

Installation

Install the stator aligning the index mark on the stator with the index mark on the left crankcase.
Install the setting plate.

Install the flywheel and washer.

NOTE

- Be careful not to contact the clutch lifter arm.
- Align the flywheel keyway with the woodruff key in the crankshaft.
- Inspect for proper operation by spinning the flywheel by hand after assembled.

Hold the flywheel with the universal holder and tighten the flywheel nut to the specified torque.



Universal holder

07725-0030000 or
Equivalent commercially
available in U.S.A.

Torque: 55 N·m (5.5 kg-m, 40 ft-lb)

Connect the alternator wire connectors.
Install the wire band.

Check the ignition timing.

Check the alternator cover rubber gasket is in good condition.

Install the alternator cover and tighten the screws.

Torque: 4 N·m (0.4 kg-m, 2.9 ft-lb)

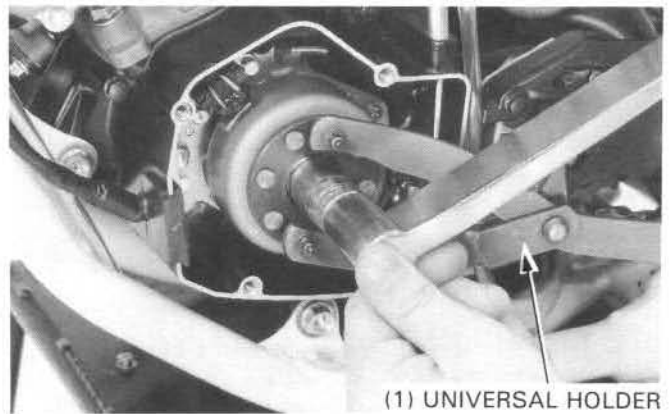
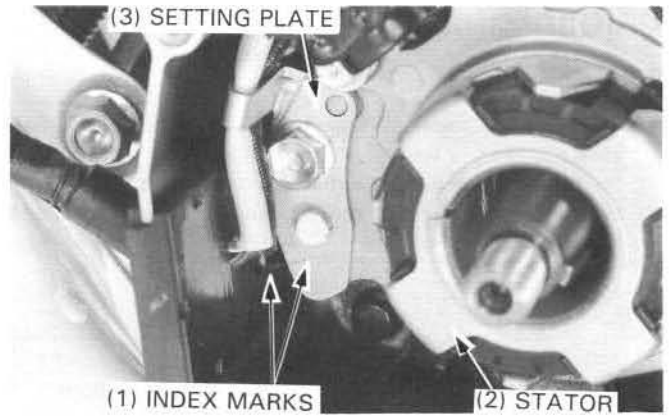

Ignition Timing

▲ WARNING

- If the engine must be running to do some work, make sure the area is well ventilated. Never run the engine in an enclosed area. The exhaust contains poisonous carbon monoxide gas that may cause loss of consciousness and lead to death.

NOTE

- The CDI ignition timing is factory preset and need only be checked when an electrical system component is replaced.

Remove the alternator cover (page 14-6).

Check that the stator index mark is aligned with the index mark on the crankcase.

Warm up the engine to normal operating temperature. Attach the timing light and tachometer according to the manufacturer's instructions.

Start the engine and hold it at 5,000 rpm while pointing the timing light towards the index mark.

If the stator's original index mark aligns between the "F" marks, the engine is timed correctly.

Remove the testing equipment and reassemble the motorcycle.

But if the stator's original index mark does not align between the "F" marks, scribe a temporary index mark on the stator base that will align between the "F" marks at 5,000 rpm. Stop the engine and do the following:

NOTE

- This procedure is to be done after replacing the CDI unit, pulse generator/stator assembly or flywheel.
- If you have checked the ignition timing as a troubleshooting method and the marks did not align, inspect the CDI unit, pulse generator and stator, before performing this procedure.

Remove the stator mounting bolt, setting plate screw and setting plate.

Elongate the setting plate mounting bolt hole, then reinstall it with its temporary index mark aligned with the index mark on the crankcase.

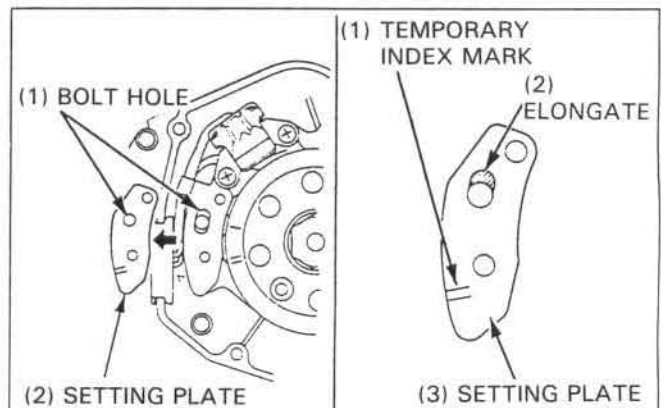
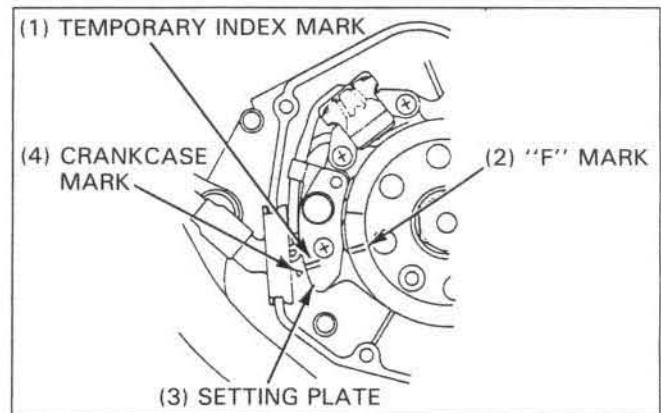
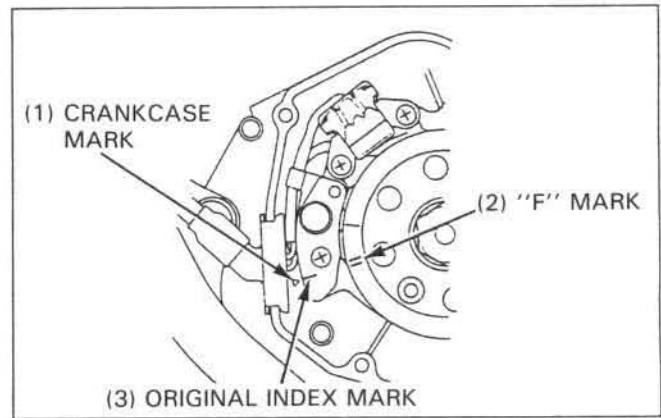

Install the setting plate and tighten the stator front mounting bolt and setting plate screw.

Recheck the ignition timing.

The crankcase index mark should now align between the "F" marks on the flywheel.

Repeat the proceeding steps if the ignition timing is not correct.

Remove the flywheel and stator front setting bolt.

Scribe a new index mark on the stator base and grind off the old index mark.

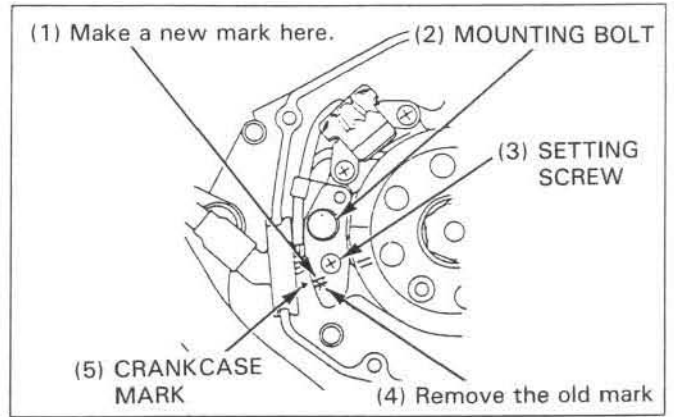

MEMO

RIDE RED

15. Wiring Diagram

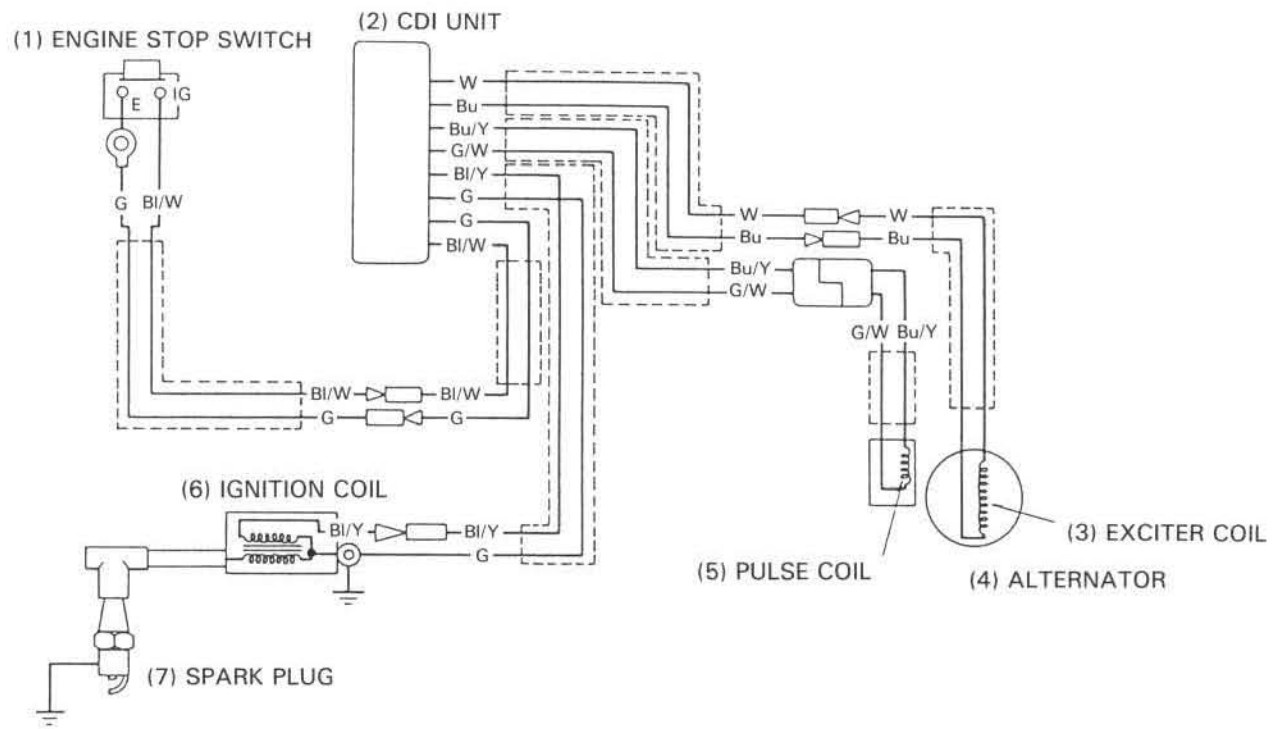

ENGINE STOP SWITCH

BUTTON	IG	E
OUT		
PUSHED IN	○	○
WIRE COLOR	Bi/W	G

Bu..... Blue
 Bl Black
 W White
 G Green
 Y Yellow

MEMO

RIDE RED

16. Technical Feature

H.P.P. (Honda Power Port)

The H.P.P. (Honda Power Port) is designed to broaden the engine's power band without sacrificing peak power. It does this by automatically varying the height of the cylinder's exhaust port. The exhaust port timing changes as engine speed increases or decreases; so that the engine can produce its best possible power output at any given engine speed.

At low engine speed, the exhaust valves are closed for mild exhaust port timing. As the engine speed increases, the exhaust valves begin to open to give maximum efficiency. At high engine speeds, the exhaust valves are fully open.

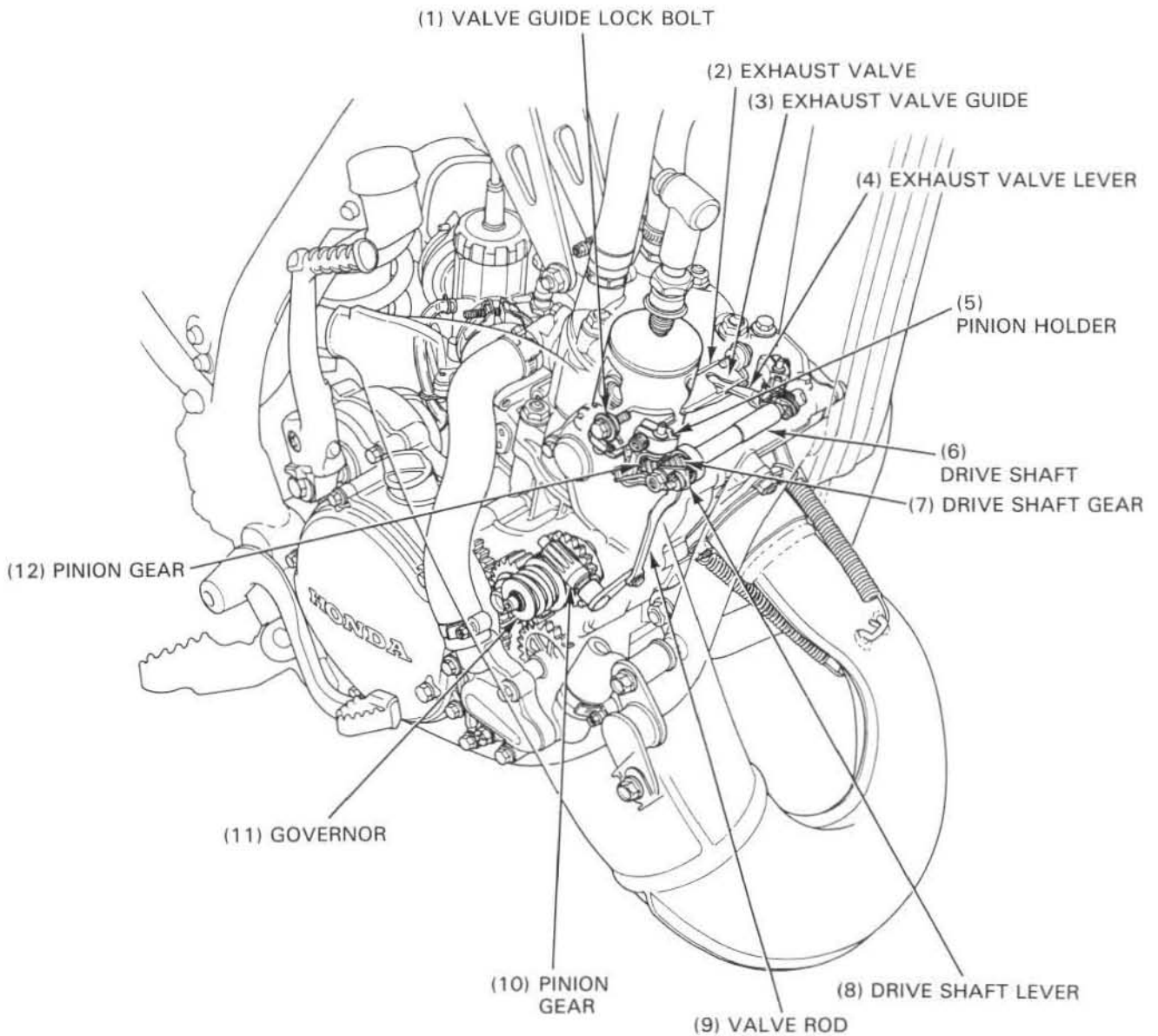

17. Troubleshooting

Engine Does Not Start Or Is Hard To Start	17-1	Poor Performance At High Speed	17-4
Engine Lacks Power	17-2	Poor Handling	17-4
Poor Performance At Low And Idle Speeds	17-3		

Engine Does Not Start Or Is Hard To Start

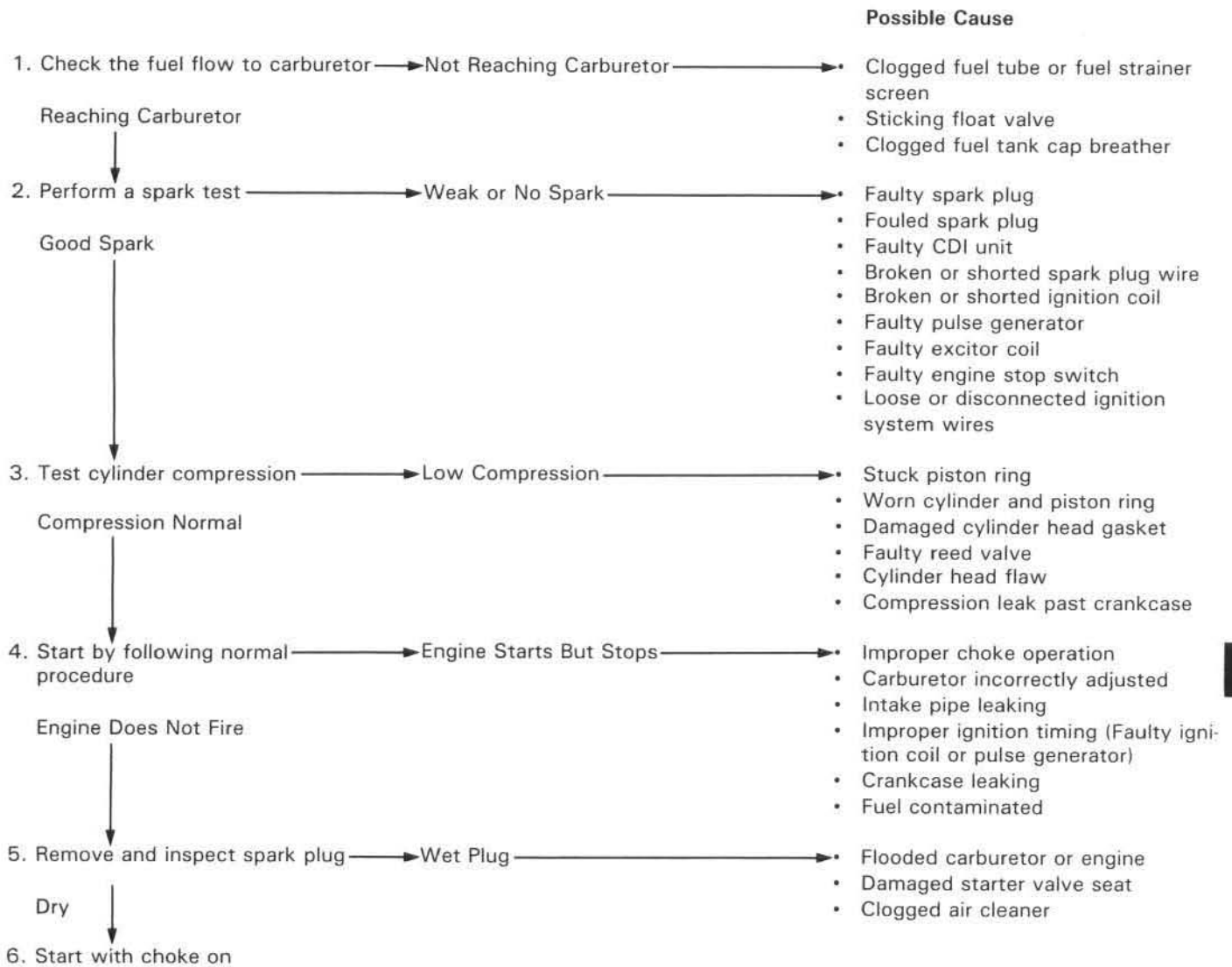

Engine Lacks Power

Possible Cause

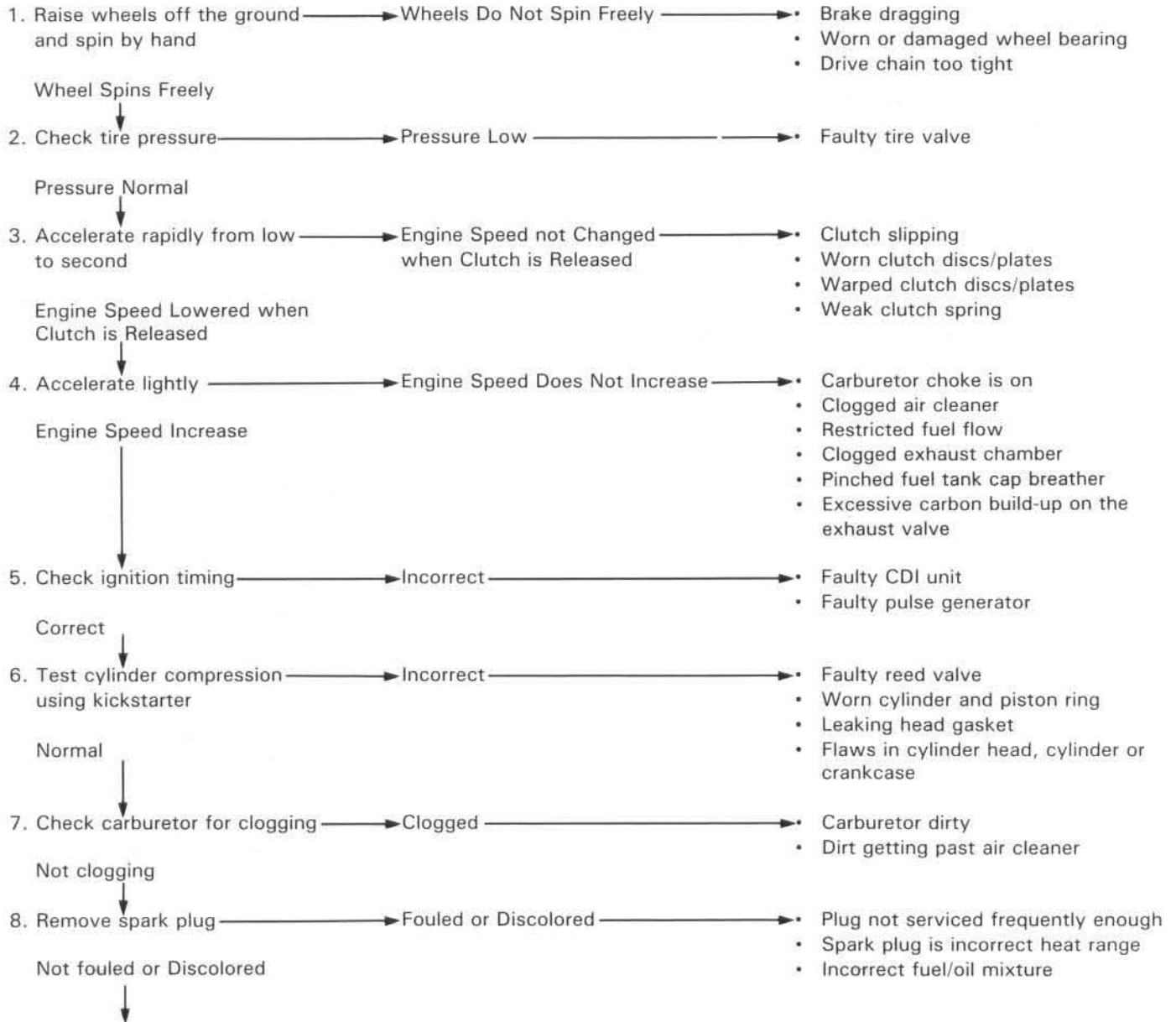

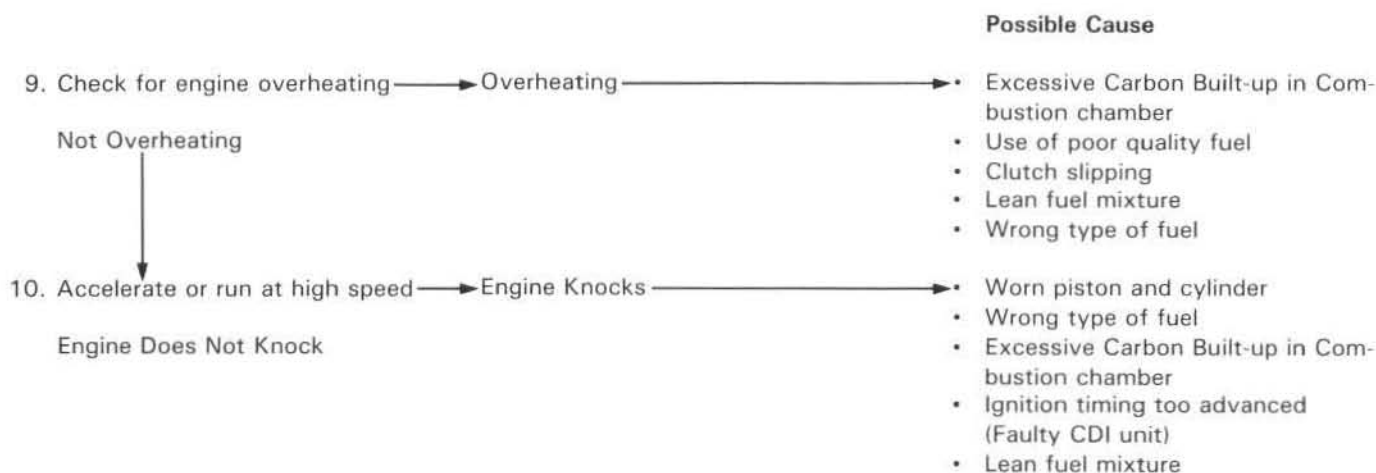

Poor Performance At Low And Idle Speed

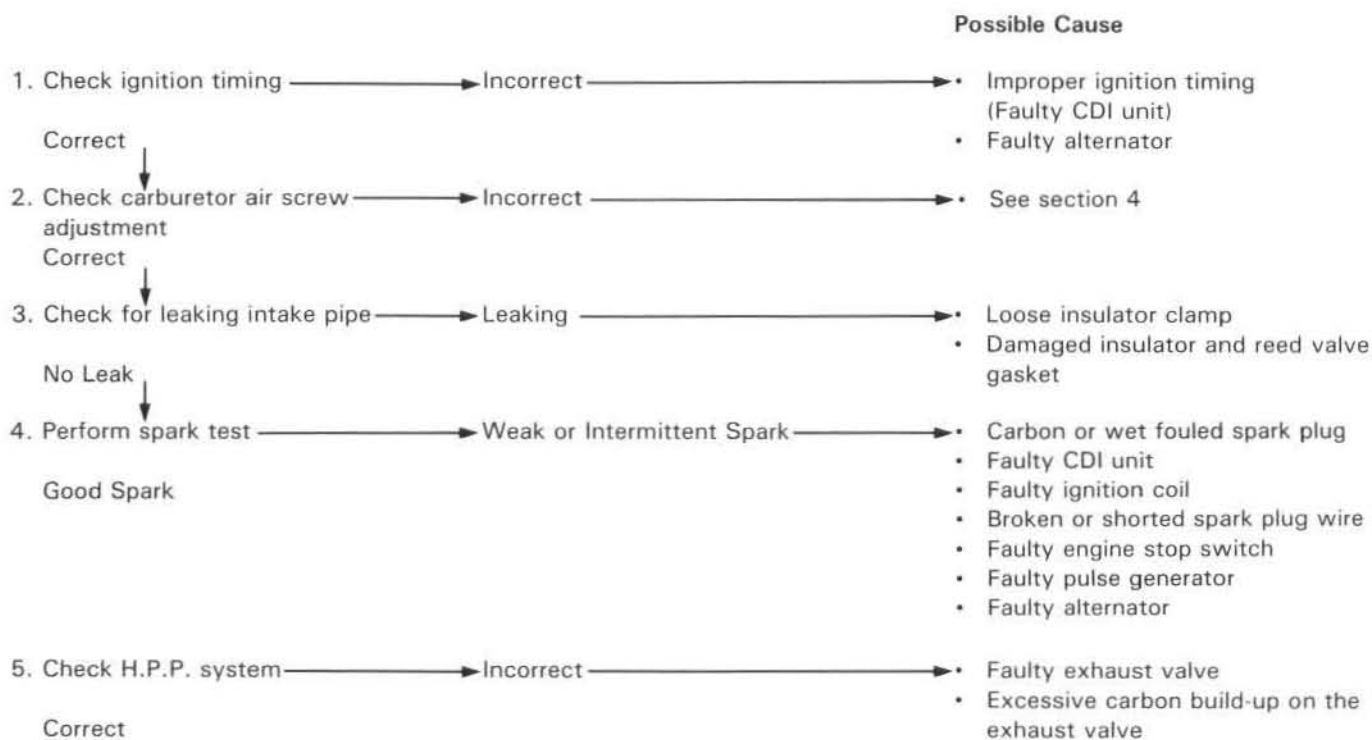

Poor Performance At High Speed

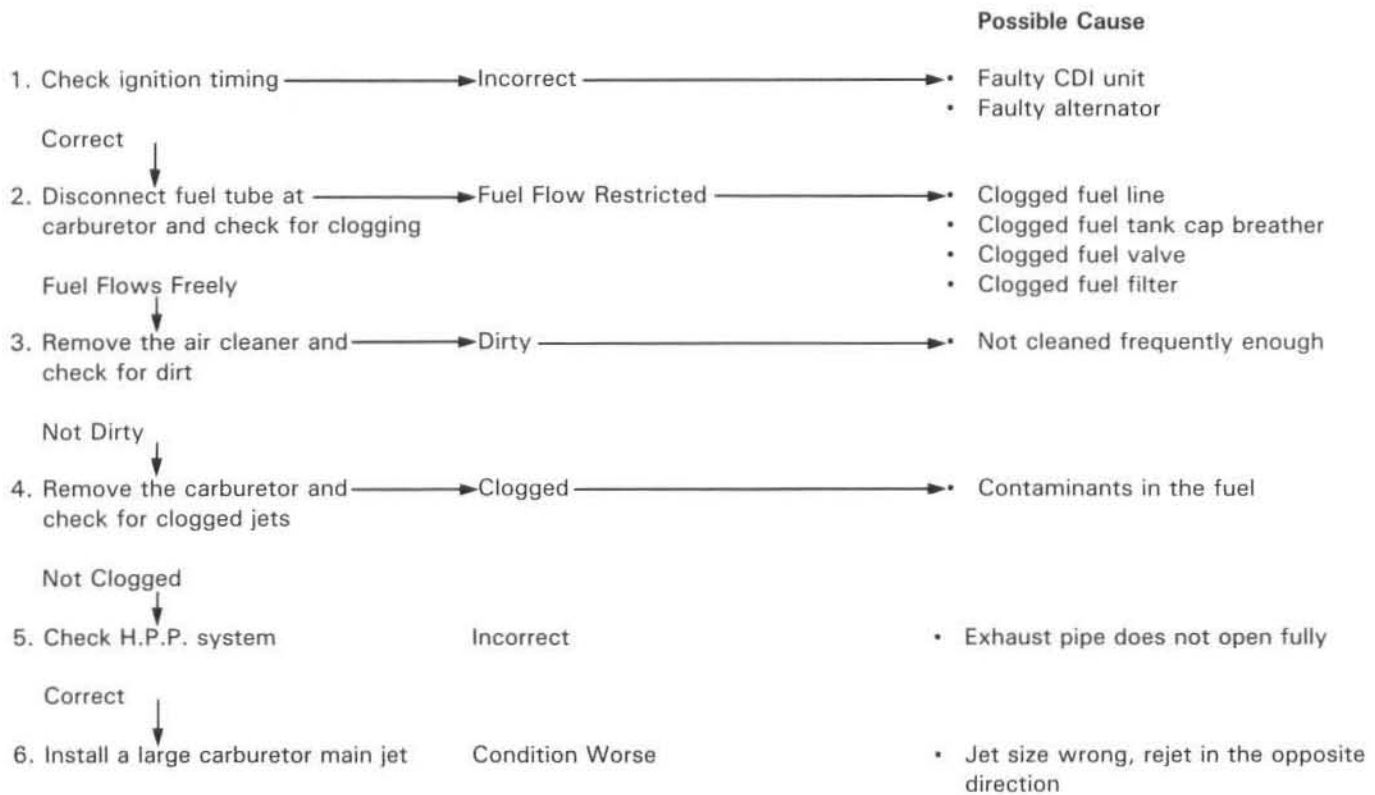

Poor Handling

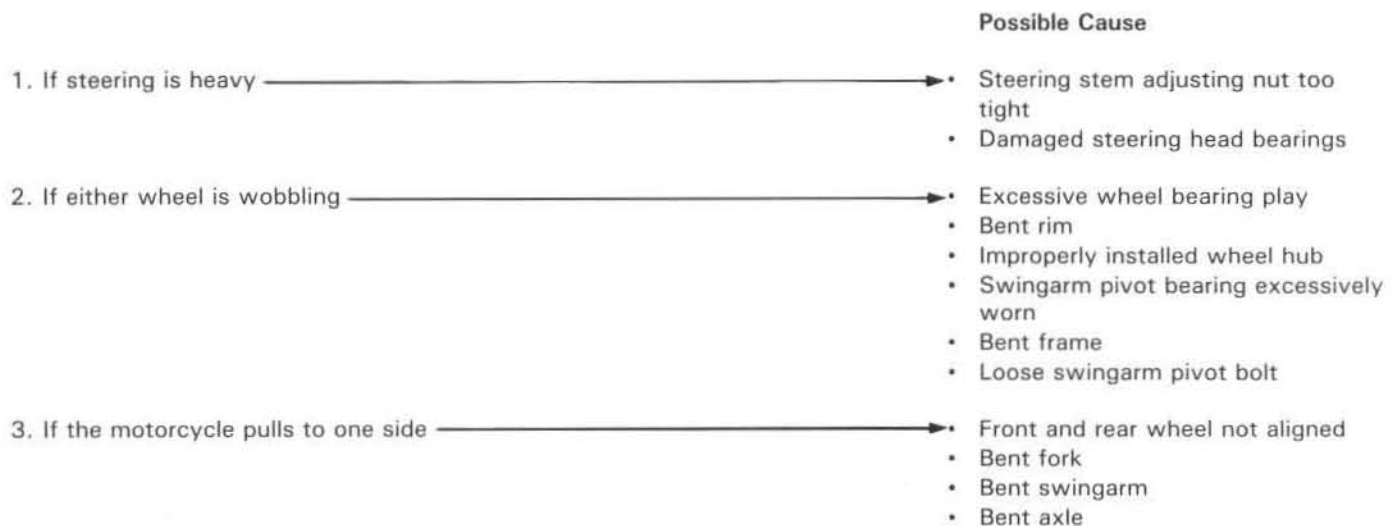

NOTE

- For the recommendations, 4 through 11, to be most useful, the motorcycle must be adjusted as follows:
 Forks— compression damping at standard position, at standard fork oil quantity and viscosity, and air pressure zero.
 Shock— nitrogen pressure 142 psi, compression and rebound damping standard position, and spring preload adjusted so the bikes sags with rider seated—see Owner’s Manual for spring preload adjustment.
- Make only one change at a time, then test ride and evaluate the difference before making further adjustments. The solutions are given in the preferred sequence of adjustment.

Possible Causes

- | | | |
|--|---|---|
| 4. Front end oversteers; it cuts too sharply (such as in sand): | → | <ul style="list-style-type: none"> • Raise fork oil level • Use stiffer fork spring |
| 5. Front end understeers; it washes out or pushes (such as on a tight track with hard ground): | → | <ul style="list-style-type: none"> • Lower fork oil level • Use softer fork spring |
| 6. Front end hunts at high speed; it wanders under power: | → | <ul style="list-style-type: none"> • Raise fork oil level • Increase shock preload |
| 7. Front end shakes under heavy braking: | → | <ul style="list-style-type: none"> • Decrease shock preload • Increase shock rebound damping • Raise fork oil level |
| 8. Front end hops over bumps in smooth turns: | → | <ul style="list-style-type: none"> • Lower fork oil level • Decrease fork compression damping • Use softer fork spring |
| 9. Rear end hops over bumps while accelerating: | → | <ul style="list-style-type: none"> • Decrease shock spring preload • Decrease shock spring compression damping |
| 10. Rear end hops over bumps while braking: | → | <ul style="list-style-type: none"> • Decrease rebound damping |
| 11. Rear end gets poor traction while accelerating away from a bumpy corner: | → | <ul style="list-style-type: none"> • Decrease shock spring preload • Decrease shock spring compression damping |

— Whenever a solution says raise or lower fork oil level, do so in increments of 5 cc (0.2 U.S. oz) and retest each time until you reach the maximum or minimum. If the performance is still unsatisfactory and the next solution is to install a softer or stiffer spring, return the oil level to the standard height and begin testing again.

— Whenever an solution says increase or decrease damping (compression or rebound), do so in increments of two clicks and retest each time until you reach the maximum or minimum. If the next solution is to install a softer or stiffer spring, return the damping adjustment to the “standard setting” and begin testing again.

— Whenever a solution says to increase or decrease shock spring preload, alter the race sag by 2.5 mm (0.1 in) and retest each time until you reach the maximum or minimum.

MEMO

RIDE RED

18. Index

Air Filter	3-6	Right Crankcase Cover	9-2
Air Filter Case	4-10	Seat	2-2
Alternator	14-5	Service Access Guide	3-2
Brake Fluid	3-12	Service Information	
Brake Fluid Replacement/Air Bleeding	13-3	(Brake System)	13-1
Brake Pad Replacement	13-5	(Clutch/Kickstarter/Gearshift Linkage)	9-1
Brake Pad Wear	3-13	(Cooling System)	5-1
Brake System	3-13	(Crankcase/Crankshaft/Transmission)	10-1
CDI Unit	14-4	(Cylinder Head/Cylinder/Piston	7-1
Cable & Harness Routing	1-18	(Engine Removal/Installation)	6-1
Carburetor Assembly/Installation	4-7	(Frame/Body Panels/Exhaust System)	2-1
Carburetor Removal/Disassembly	4-6	(Front Wheel/Suspension/Steering)	11-1
Clutch	9-3	(Fuel System)	4-1
Clutch System	3-13	(H.P.P. Honda Power Port)	8-1
Competition Maintenance Schedule	3-4	(Ignition System/Alternator)	14-1
Control Cables	3-14	(Maintenance)	3-1
Coolant Replacement	5-3	(Rear Wheel/Suspension)	12-1
Cooling System	3-8	Service Rules	1-2
Crankcase Assembly	10-10	Shock Absorber	12-8
Crankcase Bearing Replacement	10-5	Shock Linkage	12-23
Crankcase Separation	10-3	Side Cover	2-2
Crankshaft Installation	10-8	Spark Plug	3-8
Crankshaft Removal	10-5	Specifications	1-4
Cylinder/Piston	7-5	Steering Head Bearings	3-18
Cylinder Head	7-3	Steering Stem	11-22
Drive Chain	3-10	Sub-frame	2-5
Drive Chain Rollers	3-11	Suspension	3-15
Drive Chain Sliders	3-11	Swingarm	12-26
Drive/Driven Sprockets	3-12	Swingarm/Shock Linkage	3-17
Engine Installation	6-3	Technical Feature	16-1
Engine Removal	6-2	Throttle Operation	3-6
Exhaust Deposit Draining	8-2	Tools	1-14
Exhaust Pipe	2-4	Torque Values	1-11
Exhaust Valve	8-2	Transmission Assembly	10-8
Exhaust Valve Drive Shaft	8-7	Transmission Disassembly	10-4
Expansion Chamber/Silencer	3-15	Transmission Oil	3-9
Fork	11-9	Troubleshooting	
Front Brake Caliper	13-10	(Brake System)	13-2
Front Master Cylinder	13-6	(Clutch/Kickstarter/Gearshift Linkage)	9-1
Front Wheel	11-4	(Cooling System)	5-2
Fuel Tank	2-3	(Crankcase/Crankshaft/Transmission)	10-2
Gearshift Linkage	9-11	(Cylinder Head/Cylinder Piston	7-2
General Safety	1-1	(Engine Does Not Start Or Is Hard	
Governor/Valve Linkage	8-9	To Start)	17-1
Handlebar	11-9	(Engine Lacks Power)	17-2
Ignition System	14-8	(Frame/Body Panels/Exhaust System)	2-1
Kickstarter	9-9	(Front Wheel/Suspension Steering)	11-3
Lubrication & Seal Points	1-16	(Fuel System)	4-2
Major Carburetor Adjustment	4-3	(H.P.P. Honda Power Port)	8-1
Minor Carburetor Adjustment	4-3	(Ignition System/Alternator	14-2
Model Identification	1-3	(Poor Handling)	17-4
Nuts, Bolts, Fasteners	3-17	(Poor Performance At High Speed)	17-4
Optional Parts List	1-21	(Poor Performance At Low And Idle	
Radiator	5-4	Speed)	17-3
Radiator Coolant	3-8	(Rear Wheel/Suspension)	12-2
Rear Brake Caliper	13-12	Tuning For Special Condition	4-5
Rear Brake Pedal	13-14	Water Pump	5-5
Rear Master Cylinder	13-8	Wheels/Tires	3-17
Rear Wheel	12-13	Wiring Diagram	15-1
Reed Valve	4-10		

MEMO