

VULCAN 900 CLASSIC

Motorcycle

OWNER'S MANUAL

 Read this manual carefully. It contains safety information.

Kawasaki

Whenever you see the symbols shown below, heed their instructions! Always follow safe operating and maintenance practices.

 **DANGER**

DANGER indicates a hazardous situation which, if not avoided, will result in death or serious injury.

 **WARNING**

WARNING indicates a hazardous situation which, if not avoided, could result in death or serious injury.

NOTICE

NOTICE is used to address practices not related to personal injury.

NOTE

- *NOTE* indicates information that may help or guide you in the operation or service of the vehicle.

NOTICE

**THIS PRODUCT HAS BEEN
MANUFACTURED FOR USE IN A
REASONABLE AND PRUDENT
MANNER BY A QUALIFIED OP-
ERATOR AND AS A VEHICLE
ONLY.**

(Australian model only)

**TAMPERING WITH NOISE CONTROL SYSTEM
PROHIBITED**

Owners are warned that the law may prohibit:

- (a) The removal or rendering inoperative by any person other than for purposes of maintenance, repair or replacement, of any device or element of design incorporated into any new vehicle for the purpose of noise control prior to its sale or delivery to the ultimate purchaser or while it is in use; and
- (b) the use of the vehicle after such device or element of design has been removed or rendered inoperative by any person.

FOREWORD

Congratulations on your purchase of a new Kawasaki Motorcycle. Your new motorcycle is the product of Kawasaki's advanced engineering, exhaustive testing, and continuous striving for superior reliability, safety and performance.

Please read this Owner's Manual carefully before riding so that you will be thoroughly familiar with the proper operation of your motorcycle's controls, its features, capabilities, and limitations. This manual offers many safe riding tips, but its purpose is not to provide instruction in all the techniques and skills required to ride a motorcycle safely. Kawasaki strongly recommends that all operators of this vehicle enroll in a motorcycle rider training program to attain awareness of the mental and physical requirements necessary for safe motorcycle operation.

To ensure a long, trouble-free life for your motorcycle, give it the proper care and maintenance described in this manual. For those who would like more detailed information on their Kawasaki Motorcycle, a Service Manual is available for purchase from any authorized Kawasaki motorcycle dealer. The Service Manual contains detailed disassembly and maintenance information. Those who plan to do their own work should, of course, be competent mechanics and possess the special tools described in the Service Manual.

Keep this Owner's Manual aboard your motorcycle at all times so that you can refer to it whenever you need information.

This manual should be considered a permanent part of the motorcycle and should remain with the motorcycle when it is sold.

All rights reserved. No part of this publication may be reproduced without our prior written permission.

This publication includes the latest information available at the time of printing. However, there may be minor differences between the actual product and illustrations and text in this manual.

All products are subject to change without prior notice or obligation.

KAWASAKI HEAVY INDUSTRIES, LTD.
Motorcycle & Engine Company

TABLE OF CONTENTS

SPECIFICATIONS	8	Brake Lever Adjusters.....	28
LOCATION OF PARTS	12	Fuel	29
LOADING AND ACCESSORIES		Fuel Requirements:	29
INFORMATION	15	Fuel Type and Octane Rating:	30
GENERAL INFORMATION	18	Filling the Tank:.....	32
Meter Instruments	18	Side Stand	35
Speedometer:	19	Seat.....	36
Digital Display	19	Tool Kit Case	37
Fuel Gauge:.....	22	Helmet-Hook	38
RESET Button/MODE button:	22	Steering Lock	39
Warning/Indicator Lights:	22	Electric Accessory Connectors	40
Keys	24	Rear View Mirror	41
Ignition Switch	24	BREAK-IN	43
Right Handlebar Switches.....	26	HOW TO RIDE THE MOTORCYCLE .	45
Engine Stop Switch:	26	Starting the Engine	45
Starter Button:	26	Jump Starting	48
Left Handlebar Switches	27	Moving Off.....	52
Dimmer Switch:	27	Shifting Gears	53
Turn Signal Switch:.....	27	Braking	56
Horn Button:	27	Stopping the Engine.....	57

Stopping the Motorcycle in an Emergency	58	Kawasaki Clean Air System	98
Parking	59	Air Cleaner	99
Catalytic Converter.....	61	Throttle Control System	101
SAFE OPERATION	63	Idle Speed	103
Safe Riding Technique	63	Clutch.....	105
Daily Checks	66	Brakes.....	107
Additional Considerations for High Speed Operation	69	Brake Light Switches.....	111
MAINTENANCE AND ADJUSTMENT	71	Rear Shock Absorber.....	113
Periodic Maintenance Chart.....	72	Wheels	115
Engine Oil	83	Battery.....	120
Cooling System	89	Headlight Beam.....	126
Drive Belt.....	96	Fuses	127
Spark Plugs.....	96	General Lubrication.....	130
Evaporative Emission Control System (Southeast Asia B-1 and Thailand models only)	97	Cleaning Your Motorcycle	132
Valve Clearance	98	STORAGE	138
		OWNER SATISFACTION	141
		ENVIRONMENTAL PROTECTION	143
		LOCATION OF LABELS	144

8 SPECIFICATIONS

SPECIFICATIONS

PERFORMANCE

Maximum Horsepower	37 kW (50 PS) @5 700 r/min (rpm)
	(SEA-B3) 35 kW (48 PS) @5 700 r/min (rpm)
Maximum Torque	78 N·m (8.0 kgf·m, 57.5 ft·lb) @3 700 r/min (rpm)
	(SEA-B3) 77 N·m (8.0 kgf·m, 57.5 ft·lb) @3 700 r/min (rpm)
Minimum Turning Radius	2.9 m (114 in.)

DIMENSIONS

Overall Length	2 465 mm (97.0 in.)
Overall Width	1 005 mm (39.6 in.)
	(AU) 980 mm (38.6 in.)
Overall Height	1 065 mm (41.9 in.)
Wheelbase	1 645 mm (64.8 in.)
Road Clearance	135 mm (5.31 in.)
Curb Mass	282 kg (622 lb)
	(AU) 281 kg (620 lb)

ENGINE

Type	SOHC, V-type 2-cylinder, 4-stroke, liquid-cooled
Displacement	903 cm ³ (55.1 cu in.)
Bore x Stroke	88.0 x 74.2 mm (3.5 x 2.9 in.)
Compression Ratio	9.5 : 1
Starting System	Electric starter
Cylinder Numbering Method	Front to rear, 1-2
Firing Order	1-2
Fuel System	Digital fuel injection system (DFI)
Ignition System	Battery and coil (transistorized ignition)
Ignition Timing (Electronically advanced)	3.5° BTDC @1 000 r/min (rpm) ~ 53° BTDC @5 800 r/min (rpm)
Spark Plugs	NGK CPR7EA-9
Lubrication System	Forced lubrication (wet sump)

10 SPECIFICATIONS

Engine Oil:	Type	API SG, SH, SJ, SL or SM with JASO MA, MA1 or MA2
	Viscosity	SAE 10W-40
	Capacity	3.7 L (3.9 US qt)
Coolant Capacity		2.2 L (2.3 US qt)

TRANSMISSION

Transmission Type		5-speed, constant mesh, return shift
Clutch Type		Wet, multi disc
Driving System		Belt drive
Primary Reduction Ratio		2.184 (83/38)
Final Reduction Ratio		2.063 (66/32)
Overall Drive Ratio		4.338 (Top gear)
Gear Ratio	1st	2.786 (39/14)
	2nd	1.889 (34/18)
	3rd	1.360 (34/25)
	4th	1.107 (31/28)
	5th	0.963 (26/27)

FRAME

Caster		32°
Trail		160 mm (6.3 in.)
Tire Size:	Front	130/90-16 M/C 67H
	Rear	180/70-15 M/C 76H
Rim Size:	Front	J16M/C × MT3.00
	Rear	J15M/C × MT4.50
Fuel Tank Capacity		20 L (5.3 US gal)

ELECTRICAL EQUIPMENT

Battery		12 V 10 Ah (10 HR)
Headlight		12 V 60/55 W
Brake/Tail Light		12 V 21/5 W

(AU): Australian model

(SEA-B3): Southeast Asia B3 model

Specifications are subject to change without notice and may not apply to every countries.

LOCATION OF PARTS

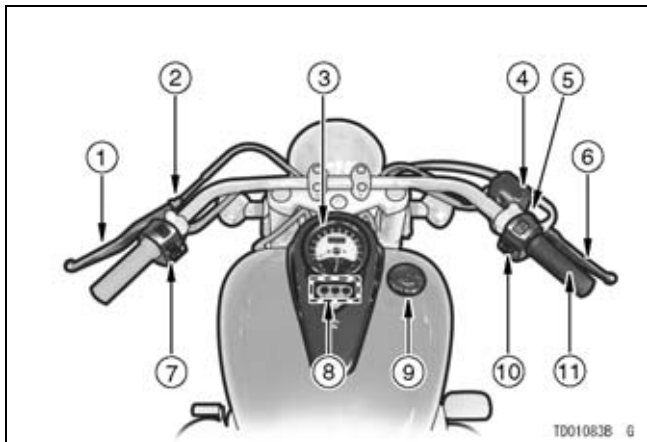

1. Clutch Lever
2. Clutch Lever Adjuster
3. Meter Instruments
4. Brake Fluid Reservoir (Front)
5. Brake Lever Adjuster
6. Front Brake Lever

7. Left Handlebar Switches
8. Indicator Lights
9. Fuel Tank Cap
10. Right Handlebar Switches
11. Throttle Grip

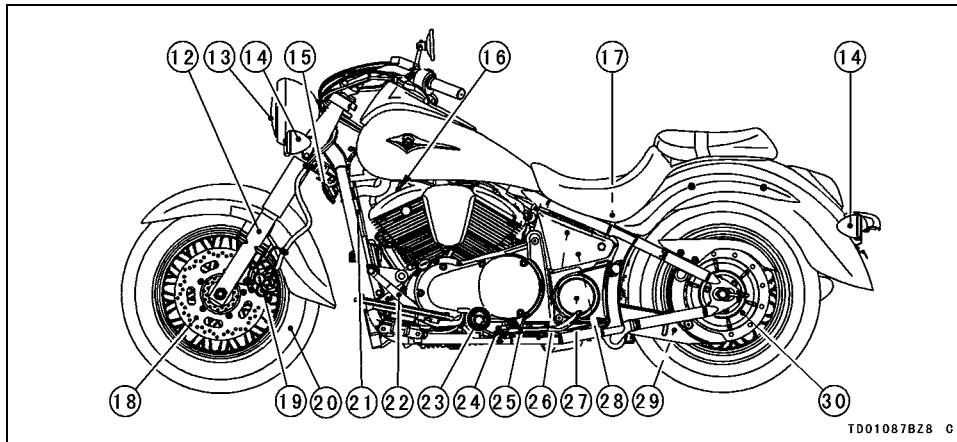

TD01087BZ8 C

- 12. Front Fork
- 13. Headlight
- 14. Turn Signal Light
- 15. Horn
- 16. Spark Plugs
- 17. Battery
- 18. Brake Disc
- 19. Brake Caliper
- 20. Wheel
- 21. Radiator

- 22. Shift Pedal
- 23. Oil Level Inspection Window
- 24. Side Stand Switch
- 25. Side Stand
- 26. Fuse Box
- 27. Coolant Reserve Tank
- 28. Rear Shock Absorber
- 29. Belt
- 30. Belt Pulley

14 LOCATION OF PARTS

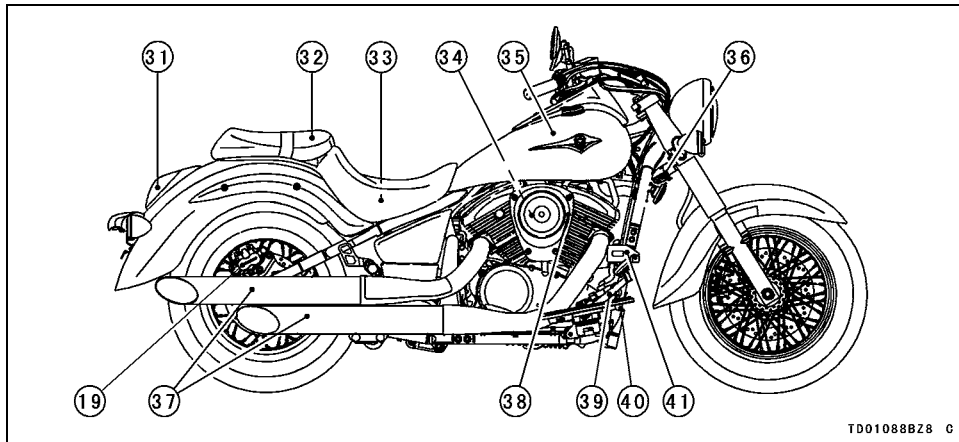

TD01088BZ8 C

31. Tail/Brake Light

32. Seat

33. Tool Kit Case/Tool Kit

34. Air Cleaner Element

35. Fuel Tank

36. Steering Lock

37. Mufflers

38. Idle Speed Adjusting Screw

39. Rear Brake Pedal

40. Rear Brake Light Switch

41. Brake Fluid Reservoir (Rear)

LOADING AND ACCESSORIES INFORMATION

 **WARNING**

Incorrect loading, improper installation or use of accessories, or modification of your motorcycle may result in an unsafe riding condition. Before you ride the motorcycle, make sure it is not overloaded and that you have followed these instructions.

With the exception of genuine Kawasaki Parts and Accessories, Kawasaki has no control over the design or application of accessories. In some cases, improper installation or use of accessories, or motorcycle modification, will void the motorcycle warranty can negatively affect performance, and can even be illegal. In

selecting and using accessories, and in loading the motorcycle, you are personally responsible for your own safety and the safety of other persons involved.

NOTE

○ *Kawasaki Parts and Accessories have been specially designed for use on Kawasaki motorcycles. We strongly recommend that all parts and accessories you add to your motorcycle be genuine Kawasaki components.*

Because a motorcycle is sensitive to changes in weight and aerodynamic forces, you must take extreme care in carrying cargo, passengers and/or in the fitting of additional accessories.

16 LOADING AND ACCESSORIES INFORMATION

The following general guidelines have been prepared to assist you in making your determinations.

1. Any passenger should be thoroughly familiar with motorcycle operation. The passenger can affect control of the motorcycle by improper positioning during cornering and sudden movements. It is important that the passenger sit still while the motorcycle is in motion and not interfere with the operation of the motorcycle. Do not carry animals on your motorcycle.
2. You should instruct any passenger before riding to keep his feet on the passenger footpegs and hold on to the operator or seat strap. Do not carry a passenger unless he or she is tall enough to reach the footpegs and footpegs are provided.
3. All baggage should be carried as low as possible to reduce the effect on the motorcycle center of gravity. Baggage weight should also be distributed equally on both sides of the motorcycle. Avoid carrying baggage that extends beyond the rear of the motorcycle.
4. Baggage should be securely attached. Make sure that the baggage will not move around while you are riding. Recheck baggage security as often as possible (not while the motorcycle is in motion) and adjust as necessary.
5. Do not carry heavy or bulky items on a luggage rack. They are designed for light items, and overloading can affect handling due to changes in weight distribution and aerodynamic forces.
6. Do not install accessories or carry baggage that impairs the performance of the motorcycle. Make sure that you have not adversely

affected any lighting components, road clearance, banking capability (i.e., lean angle), control operation, wheel travel, front fork movement, or any other aspect of the motorcycle's operation.

7. Weight attached to the handlebar or front fork will increase the mass of the steering assembly and can result in an unsafe riding condition.
8. Fairings, windshields, backrests, and other large items have the capability of adversely affecting stability and handling of the motorcycle, not only because of their weight, but also due to the aerodynamic forces acting on these surfaces while the motorcycle is in operation. Poorly designed or installed items can result in an unsafe riding condition.
9. This motorcycle was not intended to be equipped with a sidecar or to

be used to tow any trailer or other vehicle. Kawasaki does not manufacture sidecars or trailers for motorcycles and cannot predict the effects of such accessories on handling or stability, but can only warn that the effects can be adverse and that Kawasaki cannot assume responsibility for the results of such unintended use of the motorcycle. Furthermore, any adverse effects on motorcycle components caused by the use of such accessories will not be remedied under warranty.

Maximum Load

Weight of rider, passenger, baggage, and accessories must not exceed 180 kg (397 lb).

Meter Instruments

- A. Speedometer
- B. Digital Display
- C. Fuel Level Warning Indicator Light
- D. Coolant Temperature Warning Indicator Light
- E. Fuel Gauge
- F. Oil Pressure Warning Indicator Light
- G. Fuel Injection Warning Indicator Light
- H. MODE Button
- I. RESET Button
- J. Neutral Indicator Light
- K. Turn Signal indicator Light
- L. High Beam Indicator Light

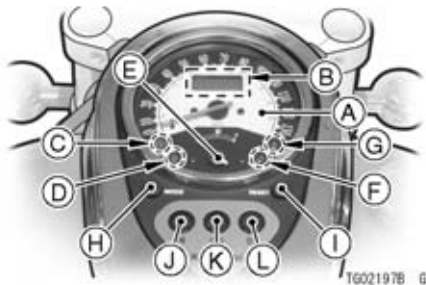

Speedometer:

The speedometer shows the speed of the vehicle.

Digital Display

The digital display located in the speedometer face is used to display the odometer, trip meter, and clock. Pushing the MODE button shifts the display through the following three modes: ODO, TRIP and CLOCK. When the ignition key is turned to "ON", all the segments are displayed for a few seconds, then the clock or meters operates normally depending on the mode selected.

Clock -

To adjust hours and minutes:

- Turn the ignition key to "ON".
- Push the MODE button to display the clock.

- Push the RESET button for more than two seconds. Both the hour and minute displays start flashing.

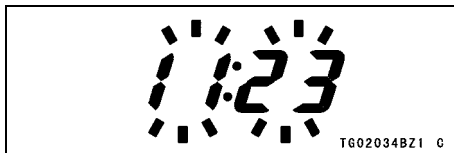

- Again push the RESET button. When only the hour display flashes, push the MODE button to advance the hours.

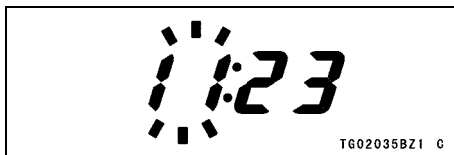

20 GENERAL INFORMATION

- Push the RESET button. The hour display stops flashing and the minute display starts flashing. Push the MODE button to advance the minutes.

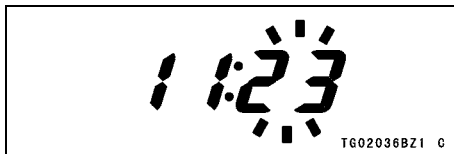

- Push the RESET button. Both the hour and minute displays start flashing again.
- Push the MODE button. The displays stop flashing and the clock starts working.

NOTE

- *Pushing the MODE button momentarily advances the hour or minute step by step. Pushing and holding the button advance the hour or minute continuously.*
- *The clock works normally from the back-up power while the ignition switch is turned off.*
- *When the battery is disconnected, the clock resets to 1:00, and starts working again when the battery is connected.*

Odometer -

The odometer shows the total distance in kilometers (miles) that the vehicle has been ridden. This meter cannot be reset.

NOTE

- *The data is maintained even if the battery is disconnected.*
- *When the figures come to 999999, they are stopped and locked.*

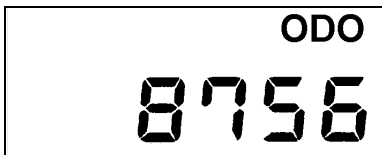
**Trip Meters -**

The trip meter shows the distance in kilometers (miles) traveled since it was last reset to zero.

To reset a trip meter:

- Push the MODE button to display the trip meter.
- Push the RESET button and hold it in.
- After two seconds, the figure display turns to 0.0, and then starts counting when the vehicle is operated. The meter counts until it is next reset.



TG023738 G

NOTE

- *The data is maintained by the back-up power if the ignition key is turned to "OFF".*
- *When the trip meter reaches 999.9 while riding, the meter resets to 0.0 and continue counting.*
- *When the battery is disconnected, the meter display resets to 0.0.*

Fuel Gauge:

The fuel gauge shows the amount of fuel in the fuel tank. When the needle comes near the E (empty) position, refuel at the earliest opportunity.

When vehicle stands with side stand, fuel gauge cannot show the amount of fuel in the fuel tank exactly. Stand upright the vehicle to check the fuel level.

RESET Button/MODE button:

The RESET button is used to reset the trip meter and to adjust the clock. The MODE button is used to shift through the digital display modes and to adjust the clock.

Warning/Indicator Lights:

N: When the transmission is in neutral, the neutral indicator light is lit.

 : When the headlight is on high beam, the high beam indicator light is lit.

 : When the turn signal switch is pushed to left or right, the turn signal indicator light flashes on and off.

 : The oil pressure warning indicator light goes on whenever the oil pressure is dangerously low or the ignition switch is in the ON position with the engine not running, and goes off when the engine oil pressure is high enough. Refer to the Maintenance and Adjustment chapter for more detailed engine oil information.

 : The warning indicator light goes on whenever the coolant temperature rises to 120°C (248°F) or higher when the motorcycle is in operation. If it stays on, stop the engine and check the coolant level in the reserve tank after the engine cools down.

FI: The fuel injection (FI) warning indicator light goes on when the ignition key is turned to “ON” and goes off soon after ensuring that its circuit functions properly. The warning indicator light also goes on whenever the troubles occur in digital fuel injection system (DFI). If the warning indicator light comes on, have the DFI system checked by an authorized Kawasaki dealer.

 : The fuel level warning indicator light goes on when approximately 4.0 L (1.0 US gal) of usable fuel remains. Refuel at the earliest opportunity when the fuel level warning indicator light comes on with the engine running.

When vehicle stands with side stand, fuel level warning indicator light cannot show the amount of fuel in the fuel tank exactly. Stand upright the vehicle to check the fuel level.

24 GENERAL INFORMATION

Keys

This motorcycle has a combination key, which is used for the ignition switch, steering lock, and fuel tank cap.

Blank keys are available at your Kawasaki dealers. Ask your dealer to make any additional spare keys you may need, using your original key as a master.

Ignition Switch

The ignition switch is located at the left side behind the rear cylinder. This is a three-position, key-operated switch. The key can be removed from the switch when it is in the OFF or P (Park) position.

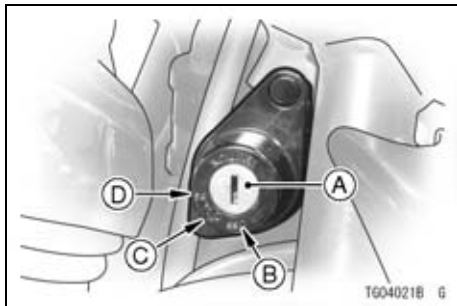

- A. Ignition Switch
- B. OFF
- C. ON
- D. P (Park)

OFF	Engine off. All electrical circuits off.
ON	Engine on. All electrical equipment can be used.
P (Park)	Engine off. Taillight and licence plate light on. All other electrical circuits cut off.

- *If you leave the motorcycle in the P (Park) position or in the ON position without the motorcycle running for a long time (one hour), the battery may become totally discharged.*

NOTE

- *The city (except for Australia model), tail and, license plate lights are on whenever the ignition switch is in the ON position. The headlight goes on when the starter button is released after starting the engine. To avoid battery discharge, always start the engine immediately after turning the ignition key to ON.*

Right Handlebar Switches

Engine Stop Switch:

In addition to the ignition switch, the engine stop switch must be in the  position for the motorcycle to operate.

The engine stop switch is for emergency use. If required, move the engine stop switch to the  position.

NOTE

- *Although the engine stop switch stops the engine, it does not turn off all the electrical circuits. Ordinarily, the ignition switch should be used to stop the engine.*

Starter Button:

The starter button operates the electric starter when the transmission is in neutral.

Refer to the Starting the Engine section of the "How to Ride the Motorcycle" chapter for starting instructions.

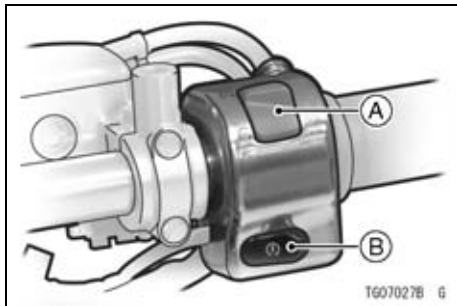



- A. Engine Stop Switch
- B. Starter Button

Left Handlebar Switches

Dimmer Switch:

High or low beam can be selected with the dimmer switch. When the headlight is on high beam (), the high beam indicator light is lit.

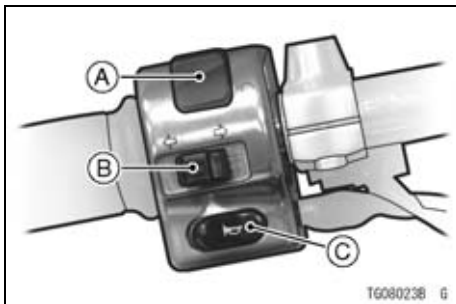

High beam.....()

Low beam.....()



- A. Dimmer Switch
- B. Turn Signal Switch
- C. Horn Button

Turn Signal Switch:

When the turn signal switch is turned to the left () or right (), the corresponding turn signals flash on and off.

To stop flashing, push the switch in.

Horn Button:

When the horn button is pushed, the horn sounds.

28 GENERAL INFORMATION

Brake Lever Adjusters

There is an adjuster on the brake lever. The adjuster has 5 positions so that the released lever position can be adjusted to suit the operator's hands. Push the lever forward and turn the adjuster to align the number with the arrow mark on the lever holder. The distance from the grip to the released lever is minimum at Number 5 and maximum at Number 1.

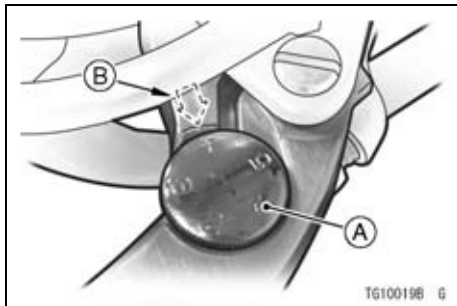

A. Adjuster
B. Arrow Mark

Fuel

Fuel Requirements:

Your Kawasaki engine is designed to use only unleaded gasoline with a minimum octane rating shown below. Never use gasoline with an octane rating lower than the minimum specified by Kawasaki to prevent severe engine damage.

The octane rating of a gasoline is a measure of its resistance to detonation or “knocking”. The term commonly used to describe a gasoline’s octane rating is the Research Octane Number (RON).

NOTICE

Do not use leaded gasoline, as this will destroy the catalytic converter. (For further information, refer to the “Catalytic Converter” section in the “How to Ride the Motorcycle” chapter.)

NOTICE

If engine “knocking” or “pinging” occurs, use a different brand of gasoline of a higher octane rating. If this condition is allowed to continue, it can lead to severe engine damage. Gasoline quality is important. Fuels of low quality or not meeting standard industry specifications may result in unsatisfactory performance. Operating problems that result from the use of poor quality or no recommended fuel may not be covered under your warranty.

Fuel Type and Octane Rating:

(Except for Australia, Brazil and Thailand Specifications)

Use clean, fresh unleaded gasoline with an octane rating equal to or higher than that shown in the table.

Fuel Type	Unleaded Gasoline
Minimum Octane Rating	Research Octane Number (RON) 91

NOTICE

Do not use any fuel with an ethanol in this vehicle. It has not been tested and certified for use with such fuels. Damage to the engine and fuel system, or engine starting and/or performance problems may result from the use of improper fuel.

(For Brazil Specification)

Use clean, fresh unleaded gasoline with an Antiknock Index equal to or higher than that shown in the table.

The Antiknock Index is posted on service station pumps. The Antiknock Index is an average of the Research Octane Number (RON) and the Motor Octane Number (MON) as shown in the table.

Fuel Type	Unleaded Gasoline
Ethanol Content	E25
Minimum Octane Rating	Antiknock Index $\frac{(\text{RON} + \text{MON})}{2}$ 87

NOTICE

Do not use any fuel that contains more ethanol or other oxygenates than specified for E25 fuel* in this vehicle. Damage to the engine and fuel system, or engine starting and/or performance problems may result from the use of improper fuel.

*E25 means fuel containing up to 25% ethanol.

(For Australia and Thailand Specification)

Use clean, fresh unleaded gasoline with an octane rating equal to or higher than that shown in the table.

32 GENERAL INFORMATION

Fuel Type	Unleaded Gasoline
Ethanol Content	E10 or less
Minimum Octane Rating	Research Octane Number (RON) 91

NOTICE

Do not use any fuel that contains more ethanol or other oxygenates than specified for E10 fuel* in this vehicle. Damage to the engine and fuel system, or engine starting and/or performance problems may result from the use of improper fuel.

*E10 means fuel containing up to 10% ethanol.

Filling the Tank:

Avoid filling the tank in the rain or where heavy dust is blowing so that the fuel does not get contaminated.

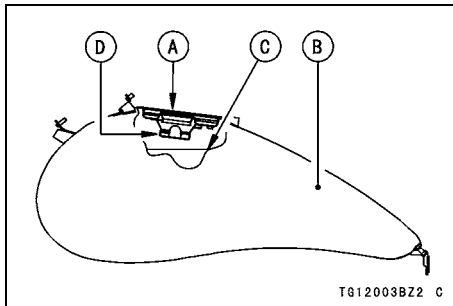

- A. Tank Cap
- B. Fuel Tank
- C. Top Level
- D. Filler Neck

 WARNING

Gasoline is extremely flammable and can be explosive under certain conditions, creating the potential for serious burns. Turn the ignition switch to “OFF”. Do not smoke. Make sure the area is well-ventilated and free from any source of flame or sparks; this includes any appliance with a pilot light. Never fill the tank completely to the top. If the tank is filled completely to the top, heat may cause the fuel to expand and overflow through the vents in the tank cap. After refueling, make sure the tank cap is closed securely. If gasoline is spilled on the fuel tank, wipe it off immediately.

NOTICE

Southeast Asia B-1 and Thailand models only:
Never fill the tank so the fuel level rises into the filler neck. If the tank is overfilled, heat may cause the fuel to expand and flow into the Evaporative Emission Control System resulting in hard starting and engine hesitation and non compliance with the emission regulation.

NOTICE

Certain ingredients in gasoline may cause paint fading or damage. Be extra careful not to spill gasoline or gasoline oxygenates blends during refueling.

34 GENERAL INFORMATION

(Fuel Tank Cap)

To open the fuel tank cap, insert the ignition key into the fuel tank cap and turn the key to the right.

To close the cap, push it down into place with the key inserted. The key can be removed by turning it to the left to the original position. Close the key hole cover.

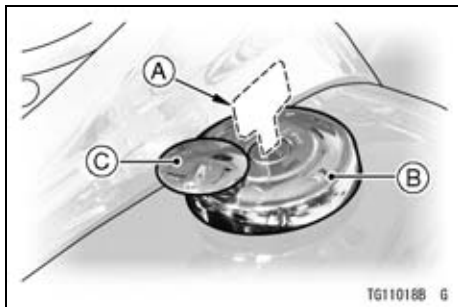

- A. Ignition Key
- B. Fuel Tank Cap
- C. Key Hole Cover

NOTE

- *The fuel tank cap cannot be closed without the key inserted, and the key cannot be removed unless the cap is locked properly.*
- *Do not push on the key to close the cap, or the cap cannot be locked.*

Side Stand

The motorcycle is equipped with a side stand.

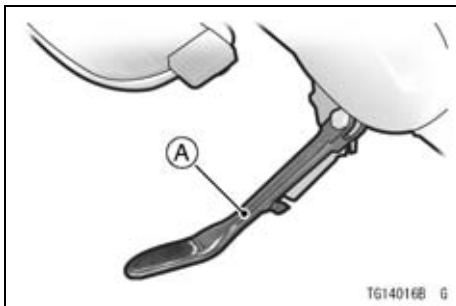

A. Side Stand

Do not sit on the motorcycle while it is on its side stand. Always kick the stand fully up before sitting on the motorcycle.

NOTE

- *The motorcycle is equipped with a side stand switch. This switch is designed so that the engine does not start if the transmission is in gear and the side stand is down.*

NOTE

- *When using the side stand, turn the handlebar to the left.*

36 GENERAL INFORMATION

Seat

Seat Removal

- To remove the seat, insert the ignition key into the seat lock, and turn the key to the right.

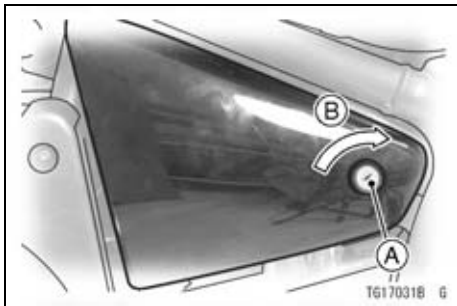

- A. Seat Lock
- B. Turn Key to Right

- Pull the seat to the rear with raising the rear of the seat.

Seat Installation

- To install the seat, insert the projection of the front on the seat into the receptacle on the frame.

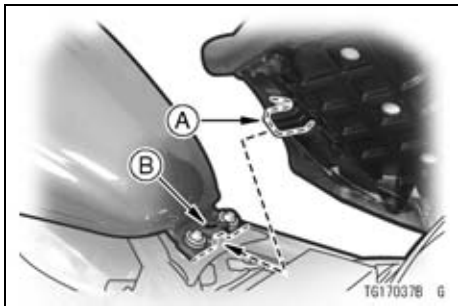

- A. Tab
- B. Slot

- Insert the hook of the middle on the seat into the holder on the frame.

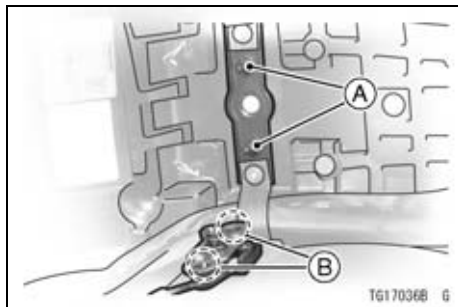

- A. Hook
B. Holder

- Pull the front and rear ends of the seat to make sure they are securely locked.

Tool Kit Case

The tool kit case is located under the seat. The kit contains tools that can be helpful in making roadside repairs, adjustments, and some maintenance procedures explained in this manual. Keep the tool kit in this case.

- Remove the seat.
- Open the tool kit case cover by pulling the knob.

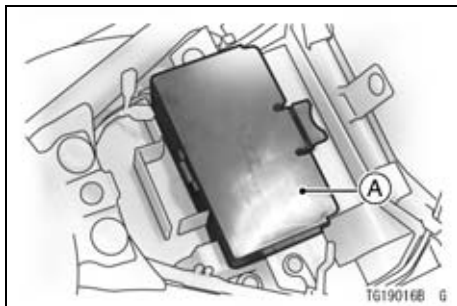

A. Tool Kit Case

38 GENERAL INFORMATION

Helmet-Hook

Helmet can be secured to the motorcycle using the helmet-hook. The helmet hook is located under the seat.

WARNING

Riding with helmet attached to the hook could cause an accident by distracting the operator or interfering with normal vehicle operation. Do not ride the motorcycle with helmet attached to the hook.

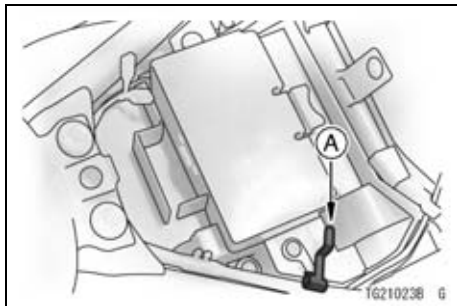

A. Helmet-Hook

Steering Lock

The motorcycle is equipped with the steering lock at the right side of the head pipe.

To lock the steering:

- Turn the handlebar to the left.
- Insert the ignition key.
- Turn the key half a turn to the left.
- Pull the key out.

NOTE

- *If the steering is hard to lock, turn the handlebar slightly to the left or the right.*
- *When unlocking the steering lock, turn the handlebar slightly to the right.*

WARNING

Attempting to ride with the steering locked could cause an accident. Unlock the steering before starting the engine.

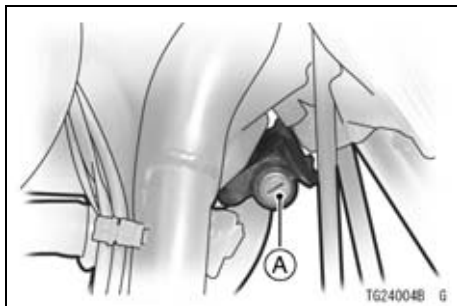

A. Steering Lock

40 GENERAL INFORMATION

Electric Accessory Connectors

The electric power of the battery can be used through the electric accessory connectors regardless of ignition switch position. Observe and follow the notes listed below.

Electric Accessory Connectors

Location	Polarity	Wire Color
Under Rider's Seat	(+)	White/Blue
	(-)	Black/Yellow
Under Fuel Tank	(+)	White/Blue
	(-)	Black/Yellow
Maximum Current :	10 A	

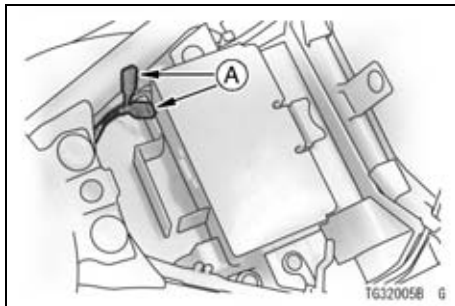

A. Electric Accessory Connectors

- When using the electric accessory connectors under the fuel tank, the electric accessory connection to the connectors should be done by an authorized Kawasaki dealer.

NOTICE

The vehicle has an electrical accessory circuit (10 A fuse) for the connectors.

Always install a fuse 10 A or less in the electrical accessory circuit.

Do not connect more than 70W of total load to the vehicle's electrical system or the battery may become discharged, even with the engine running.

 WARNING

Take care not to pinch any wire between the seat and the frame or between other parts to avoid a short circuit.

Rear View Mirror*Rear View Mirror Adjustment*

- Adjust the rear view mirror by slightly moving only the mirror portion of the assembly.
- If the rear visibility can not be assured by moving the mirror, loosen the upper hexagonal area and turn the stay by hand.

Tightening Torque

Lowering Hexagonal Area:

30 N·m (3.1 kgf·m, 22 ft·lb)

Upper Hexagonal Area:

18 N·m (1.8 kgf·m, 13 ft·lb)

NOTE

- *The upper hexagonal area (locknut) has left hand threads.*

42 GENERAL INFORMATION

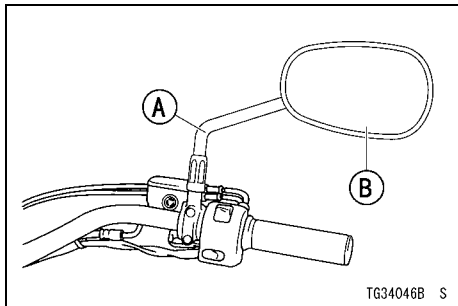

- A. Stay
- B. Rear View Mirror

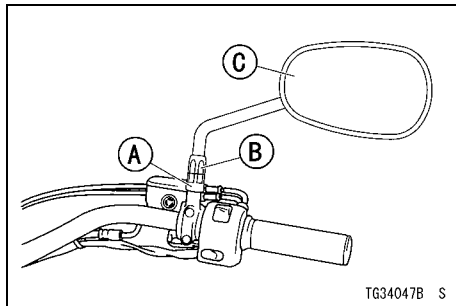

- A. Lower Hexagonal Area for Tightening
- B. Upper Hexagonal Area
- C. Rear View Mirror

NOTE

- *If a torque wrench is not available, this item should be serviced by a Kawasaki dealer.*

BREAK-IN

The first 1 600 km (1 000 mi) that the motorcycle is ridden is designated as the break-in period. If the motorcycle is not used carefully during this period, you may very well end up with a "broken down" instead of a "broken in" motorcycle after a few thousand kilometers.

The following rules should be observed during the break-in period.

- The table shows maximum recommended speed in km/h (mph) during the break-in period.

km/h (mph)

Gear position	1st	2nd	3rd	4th	5th
Distance traveled					
0 ~ 800 km (0 ~ 500 mi)	32 (20)	50 (30)	65 (40)	80 (50)	95 (60)
800 ~ 1 600 km (500 ~ 1 000 mi)	40 (25)	65 (40)	90 (55)	100 (70)	130 (80)

NOTE

- *When operating on public roadways, keep maximum speed under traffic law limits.*
- Do not start moving or race the engine immediately after starting it, even if the engine is already warm. Run the engine for two or three minutes at idle speed to give the oil a chance to work up into all the engine parts.
- Do not race the engine while the transmission is in neutral.

WARNING

New tires are slippery and may cause loss of control and injury. A break-in period of 160 km (100 mi) is necessary to establish normal tire traction. During break-in, avoid sudden and maximum braking and acceleration, and hard cornering.

In addition to the above, at 1 000 km (600 mi) it is extremely important that the owner has the initial maintenance service performed by an authorized Kawasaki dealer.

HOW TO RIDE THE MOTORCYCLE

Starting the Engine

- Check that the engine stop switch is in the  position.

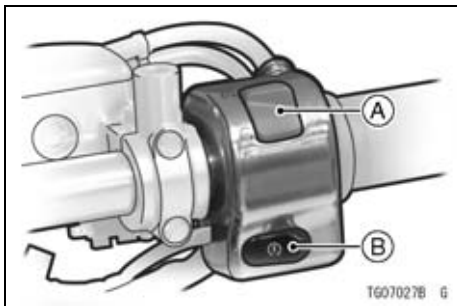

- A. Engine Stop Switch
- B. Starter Button

- Turn the ignition key to ON.

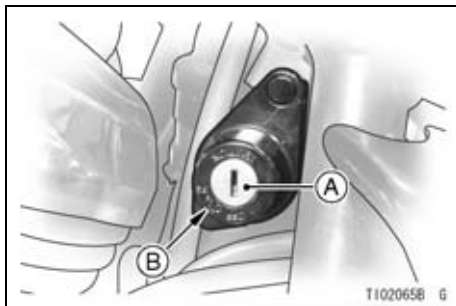

- A. Ignition Switch
- B. ON Position

46 HOW TO RIDE THE MOTORCYCLE

- Make sure the transmission is in neutral.

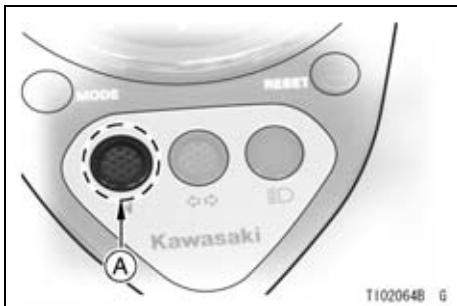

A. Neutral Indicator Light

NOTE

- *While the engine is cold, the fast idle system automatically raises the engine idling speed. At this time, the fuel injection warning indicator light may go on if you operate the throttle grip unnecessarily.*

- *The motorcycle is equipped with a vehicle-down sensor, which causes the engine to stop automatically when the motorcycle falls down. After righting the motorcycle, first turn the ignition key to “OFF” and then back to “ON” before starting the engine.*

- Without holding the throttle grip, push the starter button to start the engine.

NOTICE

Do not operate the starter continuously for more than 5 seconds, or the starter will overheat and the battery power will drop temporarily. Wait 15 seconds between each operation of the starter to let it cool and the battery power recover.

NOTE

- *The motorcycle is equipped with a starter lockout switch. This switch is designed so that the engine does not start if the transmission is in gear and the side stand is down. However, the engine can be started if the clutch lever is pulled and the side stand is fully up.*

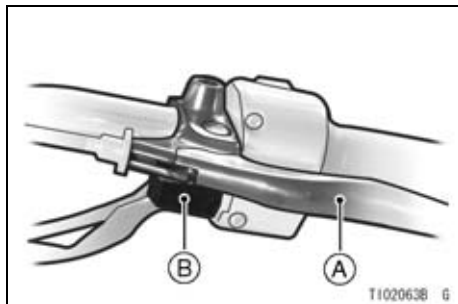

- A. Clutch Lever**
- B. Starter Lockout Switch**

NOTICE

Do not let the engine idle longer than five minutes, or engine overheating and damage may occur.

Jump Starting

If your motorcycle battery is "run down", it should be removed and charged. If this is not practical, a 12 volt booster battery and jumper cables may be used to start the engine.

DANGER

Battery acid generates hydrogen gas which is flammable and explosive under certain conditions. It is present within a battery at all times, even in a discharged condition. Keep all flames and sparks (cigarettes) away from the battery. Wear eye protection when working with a battery. In the event of battery acid contact with skin, eyes, or clothing, wash the affected areas immediately with water for at least five minutes. Seek medical attention.

Connecting Jumper Cables

- Make sure the ignition key is turned to "OFF".
- Remove the seat.
- Remove the tool kit case by unscrewing the helmet-hook mounting screws.

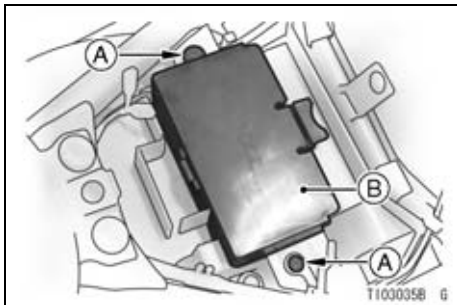

- A. Screw
- B. Tool Kit Case

- Connect a jumper cable from the positive (+) terminal of the booster battery to the positive (+) terminal of the motorcycle battery.

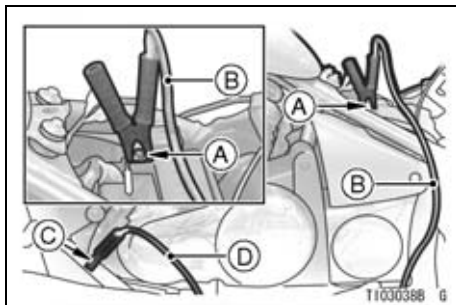

- A. Motorcycle Battery Positive (+) Terminal
- B. From Booster Battery Positive (+) Terminal
- C. Unpainted Metal Surface
- D. From Booster Battery Negative (-) Terminal

50 HOW TO RIDE THE MOTORCYCLE

- Connect another jumper cable from the negative (-) terminal of the booster battery to your motorcycle shift pedal or other unpainted metal surface. Do not use the negative (-) terminal of the battery.

DANGER

Batteries contain sulfuric acid that can cause burns and produce hydrogen gas which is highly explosive. Do not make this last connection at the fuel system or battery. Take care not to touch the positive and negative cables together, and do not lean over the battery when making this last connection. Do not connect to a frozen battery. It could explode. Do not reverse polarity by connecting positive (+) to negative (-), or a battery explosion and serious damage to the electrical system may occur.

- Follow the standard engine starting procedure.

NOTICE

Do not operate the starter continuously for more than 5 seconds or the starter will overheat and the battery power will drop temporarily. Wait 15 seconds between each operation of the starter to let it cool and the battery power recover.

- After the engine has started, disconnect the jumper cables. Disconnect the negative (-) cable from the motorcycle first. Reinstall the parts removed.

NOTE

- *After installing the tool kit case, run the seat lock cable and wires along the guide.*

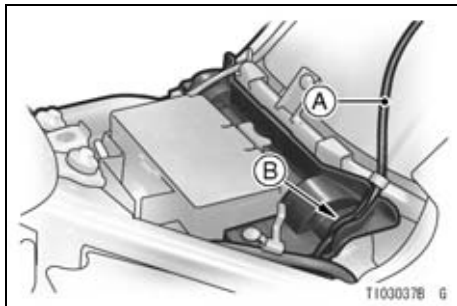

- A. Seat Lock Cable
- B. Guide

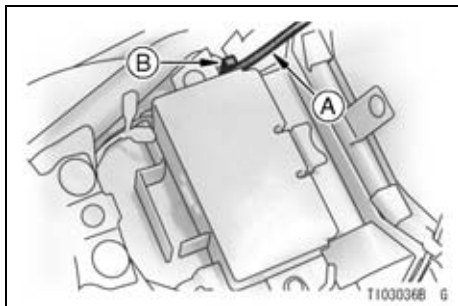

A. Harness

B. Guide

Moving Off

- Check that the side stand is up.
- Pull in the clutch lever.
- Shift into 1st gear.
- Open the throttle a little, and start to let out the clutch lever very slowly.
- As the clutch starts to engage, open the throttle a little more, giving the engine just enough fuel to keep it from stalling.

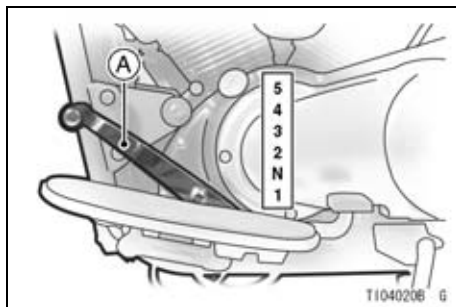

A. Shift Pedal

NOTE

- *The motorcycle is equipped with a side stand switch. This switch is designed so that the engine does not start if the transmission is in gear and the side stand is down.*

Shifting Gears

- Close the throttle while pulling in the clutch lever.
- Shift into the next higher or lower gear.

 **WARNING**

Downshifting at high speed can make the rear wheel skid and cause an accident resulting in severe injury or death, as well as cause the engine to overrev and damage it. When shifting down to a lower gear, do not shift at such a high speed that engine rpm jumps excessively. Downshift at the vehicle speeds shown in the table in this section.

54 HOW TO RIDE THE MOTORCYCLE

- Open the throttle part way, while releasing the clutch lever.

NOTE

- *The transmission is equipped with a positive neutral finder. When the motorcycle is standing still, the transmission cannot be shifted past neutral from 1st gear. To use the positive neutral finder, shift down to 1st gear, then lift up on the shift pedal while standing still. The transmission will shift only into neutral.*

Vehicle speed when downshifting

Shifting down	km/h (mph)
5th → 4th	40 (25)
4th → 3rd	30 (19)
3rd → 2nd	20 (12)
2nd → 1st	15 (9)

Braking

- Close the throttle completely, leaving the clutch engaged (except when shifting gears) so that the engine will help slow down the motorcycle.
- Shift down one gear at a time so that you are in 1st gear when you come to a complete stop.
- When stopping, always apply both brakes at the same time. Normally the front brake should be applied a little more than the rear. Shift down or fully disengage the clutch as necessary to keep the engine from stalling.
- Never lock the brakes, or it will cause the tires to skid. When turning a corner, it is better not to brake at all. Reduce your speed before you get into the corner.

- For emergency braking, disregard downshifting, and concentrate on applying the brakes as hard as possible without skidding.

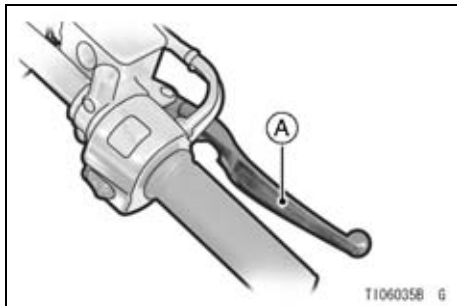

A. Front Brake Lever



A. Rear Brake Pedal

Stopping the Engine

- Close the throttle completely.
- Shift the transmission into neutral.
- Turn the ignition key to “OFF” .
- Support the motorcycle on a firm, level surface with the side stand.
- Lock the steering.

NOTE

- *The motorcycle is equipped with a vehicle-down sensor, which causes the engine to stop automatically when the motorcycle falls down. After righting the motorcycle, first turn the ignition key to “OFF” and then back to “ON” before starting the engine.*

Stopping the Motorcycle in an Emergency

Your Kawasaki Motorcycle has been designed and manufactured to provide you optimum safety and convenience. However, in order to fully benefit from Kawasaki's safety engineering and craftsmanship, it is essential that you, the owner and operator, properly maintain your motorcycle and become thoroughly familiar with its operation. Improper maintenance can create a dangerous situation known as throttle failure.

Two of the most common causes of throttle failure are:

1. An improperly serviced or clogged air cleaner may allow dirt and dust to enter the throttle body and stick the throttle open.

2. During removal of the air cleaner, dirt is allowed to enter and jam the throttle body.

In an emergency situation such as throttle failure, your vehicle may be stopped by applying the brakes and disengaging the clutch. Once this stopping procedure is initiated, the engine stop switch may be used to stop the engine. If the engine stop switch is used, turn off the ignition switch after stopping the motorcycle.

Parking

WARNING

Operating or parking the vehicle near flammable materials can cause a fire, and can result in property damage or severe personal injury.

Do not idle or park your vehicle in an area where tall or dry vegetation, or other flammable materials could come into contact with the muffler or exhaust pipe.

WARNING

The engine and exhaust system get extremely hot during normal operation and can cause serious burns.

Never touch a hot engine, exhaust pipe, or muffler during operation or after stopping the engine.

- Shift the transmission into neutral and turn the ignition key to “OFF”.
- Support the motorcycle on a firm, level surface with the side stand.

NOTICE

Do not park on a soft or steeply inclined surface, or the motorcycle may fall over.

60 HOW TO RIDE THE MOTORCYCLE

- If parking inside a garage or other structure, be sure it is well ventilated and the motorcycle is not close to any source of flame or sparks; this includes any appliance with a pilot light.

WARNING

Gasoline is extremely flammable and can be explosive under certain conditions, creating the potential for serious burns. Turn the ignition switch “OFF”. Do not smoke. Make sure the area is well ventilated and free from any source of flame or sparks; this includes any appliance with a pilot light.

- Lock the steering to help prevent theft.

NOTE

- *When stopping near traffic at night, you can leave the taillight, licence plate light on for greater visibility by turning the ignition key to the P (Park) position.*
- *Do not leave the ignition switch at P position too long, or the battery will discharge.*

Catalytic Converter

This motorcycle is equipped with a catalytic converter in the exhaust system. The converter react with carbon monoxide, hydrocarbons and nitrogen oxides to convert them into carbon dioxide, water, nitrogen and oxygen resulting in much cleaner exhaust gases to be discharged into the atmosphere.

For proper operation of the catalytic converter, the following cautions must be observed.

WARNING

Operating or parking the vehicle near flammable materials can cause a fire, and can result in property damage or severe personal injury.

Do not idle or park your vehicle in an area where tall or dry vegetation, or other flammable materials could come into contact with the muffler or exhaust pipe.

WARNING

The engine and exhaust system get extremely hot during normal operation and can cause serious burns.

Never touch a hot engine, exhaust pipe, or muffler during operation or after stopping the engine.

62 HOW TO RIDE THE MOTORCYCLE

- Use only unleaded gasoline. Never use leaded gasoline. Leaded gasoline significantly reduces the capability of the catalytic converter.
- Do not operate the vehicle with the engine or any one cylinder misfiring. Under these conditions unburned air/fuel mixture flowing out of engine excessively accelerates reaction in the converter allowing the converter to overheat and become damaged when the engine is hot, or reduces converter performance when the engine is cold.

SAFE OPERATION

Safe Riding Technique

The points given below are applicable for everyday motorcycle use and should be carefully observed for safe and effective vehicle operation.

For safety, eye protection and a helmet are strongly recommended. You should be aware of and verify the applicable safety regulations in force prior to riding your motorcycle. Gloves and suitable footwear should also be used for added protection in case of mishap.

A motorcycle does not provide the impact protection of an automobile, so defensive riding in addition to wearing protective apparel is extremely important. Do not let protective apparel give you a false sense of security.

When riding always keep both hands on the handlebars and both feet on the footpegs. Removing your hands from the handlebars or feet from the footpegs while riding can be hazardous. If you remove even one hand or foot, you can reduce your ability to control the motorcycle.

Before changing lanes, look over your shoulder to make sure the way is clear. Do not rely solely on the rear view mirror; you may misjudge a vehicle's distance and speed, or you may not see it at all.

64 SAFE OPERATION

In general your actions should be smooth as sudden acceleration, braking or turning may cause loss of control, especially when riding in wet conditions or on loose roadway surfaces, when the ability to maneuver will be reduced.

When going up steep slopes, shift to a lower gear so that there is plenty of power to spare rather than overloading the engine.

When applying the brakes, use both the front and rear brakes. Applying only one brake for sudden braking may cause the motorcycle to skid and lose control.

When going down long slopes, control vehicle speed by closing the throttle. Use the front and rear brakes for auxiliary braking.

In wet conditions, rely more on the throttle to control vehicle speed and less on the front and rear brakes. The throttle should also be used judiciously to avoid skidding the rear wheel from too rapid acceleration or deceleration.

Riding at the proper rate of speed and avoiding unnecessarily fast acceleration are important not only for safety and low fuel consumption but also for long vehicle life and quieter operation.

On rough roads, exercise caution, slow down, and grip the fuel tank with the knees for better stability.

When quick acceleration is necessary as in passing, shift to a lower gear to obtain the necessary power.

Do not downshift at too high an r/min (rpm) to avoid damage to the engine from overrevving.

Avoiding unnecessary weaving is important to the safety of both the rider and other motorists.

Daily Checks

Check the following items each day before you ride. The time required is minimal, and habitual performance of these checks will help ensure you a safe, reliable ride.

If any irregularities are found during these checks, refer to the Maintenance and Adjustment chapter or see your dealer for the action required to return the motorcycle to a safe operating condition.

WARNING

Failure to perform these checks before operation may result in serious damage or an accident. Always perform daily checks before operation.

DANGER

Exhaust gas contains carbon monoxide, a colorless, odorless poisonous gas.

Inhaling carbon monoxide can cause serious brain injury or death.

Do not run the engine in enclosed areas. Operate only in a well-ventilated area.

Fuel Adequate supply in tank, no leaks.

Engine oil Oil level between level lines.

Tires Air pressure (when cold):

Front	Up to 180 kg Load (397 lb)	200 kPa (2.00 kgf/cm ² , 28 psi)
Rear	Up to 97.5 kg (215 lb) load	200 kPa (2.0 kgf/cm ² , 28 psi)
	97.5 ~ 180 kg (215 ~ 397 lb) load	225 kPa (2.25 kgf/cm ² , 32 psi)

Install the air valve cap.

- Nuts, bolts, fasteners .. Check that steering and suspension components, axles, and all controls are properly tightened or fastened.
- Steering Action smooth but not loose from lock to lock.
No binding of control cables.
- Brakes Brake pad wear: Lining thickness more than 1 mm (0.04 in.) left.
No brake fluid leakage.
- Throttle Throttle grip play 2 ~ 3 mm (0.08 ~ 0.12 in.).
- Clutch Clutch lever play 2 ~ 3 mm (0.08 ~ 0.12 in.).
Clutch lever operates smoothly.
- Coolant No coolant leakage.
Coolant level between level lines (when engine is cold).
- Electrical equipment ... All lights (Headlight, Tail/Brake Lights, Turn Signal Lights Warning/Indicator Lights) and horn work.
- Engine stop switch Stops engine.

68 SAFE OPERATION

Side stand Returns to its fully up position by spring tension.
Return spring not weak or not damaged.

Additional Considerations for High Speed Operation

WARNING

Handling characteristics of a motorcycle at high speeds may vary from those you are familiar with at legal highway speeds. Do not attempt high speed operation unless you have received sufficient training and have the required skills.

Brakes: The importance of the brakes, especially during high speed operation, cannot be overemphasized. Check to see that they are correctly adjusted and functioning properly.

Steering: Looseness in the steering can cause loss of control. Check to see that the handlebar turns freely but has no play.

Tires: High speed operation is hard on tires, and good tires are crucial for riding safety. Examine their overall condition, inflate them to the proper pressure, and check the wheel balance.

Fuel: Have sufficient fuel for the high fuel consumption during high speed operation.

Spark Plugs: For demanding operation such as racing, install spark plugs with one heat colder range NGK CPR8EA-9.

Engine Oil: To avoid engine seizure and resulting loss of control, make sure that the oil level is at the upper level line.

70 SAFE OPERATION

Coolant: To avoid overheating, check that the coolant level is at the upper level line.

Electrical Equipment: Make sure that the headlight, tail/brake light, turn signals, horn, etc., all work properly.

Miscellaneous: Make sure that all nuts and bolts are tight and that all safety related parts are in good condition.

MAINTENANCE AND ADJUSTMENT

The maintenance and adjustments outlined in this chapter must be carried out and must be done in accordance with the Periodic Maintenance Chart to keep the motorcycle in good running condition. **The initial maintenance is vitally important and must not be neglected.**

With a basic knowledge of mechanics and the proper use of tools, you should be able to carry out many of the maintenance items described in this chapter. If you lack proper experience or doubt your ability, all adjustments, maintenance, and repair work should be completed by a qualified technician.

Please note that Kawasaki cannot assume any responsibility for damage resulting from incorrect or improper adjustment done by the owner.

72 MAINTENANCE AND ADJUSTMENT

Periodic Maintenance Chart

K : Should be serviced by an authorized Kawasaki dealer.

* : For higher odometer readings, repeat at the frequency interval established here.

: Service more frequently when operating in severe conditions: dusty, wet, muddy, high speed, or frequent starting/stopping.

1. Periodic Inspection (Engine Related Items)

Frequency	Whichever comes first →								See Page
	*Odometer Reading km × 1000 (mile × 1000)								
Operation (Engine Items)	Every	1 (0.6)	6 (3.75)	12 (7.5)	18 (11.25)	24 (15)	30 (18.75)	36 (22.5)	
K Valve clearance - inspect		Every 42 000 km (26 000 mile)							98
Throttle control system (play, smooth return, no drag) - inspect	year	●		●		●		●	101
Idle speed - inspect		●		●		●		●	103

Frequency	Operation (Engine Items)	Whichever comes first →							*Odometer Reading km × 1000 (mile × 1000)	See Page
		↓ Every	1 (0.6)	6 (3.75)	12 (7.5)	18 (11.25)	24 (15)	30 (18.75)		
K	Fuel leak (fuel hose and pipe) - inspect	year	●		●		●		●	–
K	Fuel hoses damage - inspect	year	●		●		●		●	–
K	Fuel hoses installation condition - inspect	year	●		●		●		●	–
	Coolant level - inspect		●		●		●		●	92
	Coolant leak - inspect	year	●		●		●		●	–
	Radiator hose damage - inspect	year	●		●		●		●	90
	Radiator hoses installation condition - inspect	year	●		●		●		●	90

2. Periodic Inspection (Chassis Related Items)

Frequency	Whichever comes first							*Odometer Reading km × 1000 (mile × 1000)	See Page
	↓	→							
Operation (Chassis Items)	Every	1 (0.6)	6 (3.75)	12 (7.5)	18 (11.25)	24 (15)	30 (18.75)	36 (22.5)	
Clutch and drive train:									
Clutch operation (play, engagement, disengagement) - inspect		•		•		•		•	105
K Drive belt deflection - inspect		•	•	•	•	•	•	•	96
K Drive belt wear - inspect		•	•	•	•	•	•	•	96
Wheels and tires:									
Tire air pressure - inspect	year			•		•		•	116

78 MAINTENANCE AND ADJUSTMENT

Frequency	Whichever comes first →								*Odometer Reading km × 1000 (mile × 1000)	See Page
	↓	1	6	12	18	24	30	36		
Operation (Chassis Items)	Every	(0.6)	(3.75)	(7.5)	(11.25)	(15)	(18.75)	(22.5)		
Suspensions:										
K Front forks/rear shock absorber operation (damping and smooth stroke) - inspect				●		●		●		—
K Front forks/rear shock absorber oil leak - inspect	year			●		●		●		—
K Swing arm pivot - lubricate						●				—
K Uni-trak rocker arm operation - inspect				●		●		●		—
K Uni-trak tie rods operation - inspect				●		●		●		—

Frequency	Whichever comes first →								See Page
	↓	*Odometer Reading km × 1000 (mile × 1000)							
Operation (Chassis Items)	Every	1 (0.6)	6 (3.75)	12 (7.5)	18 (11.25)	24 (15)	30 (18.75)	36 (22.5)	
K Uni-trak rocker arm bearings - lubricate						•			–
K Uni-trak tie rods bearings - lubricate						•			–
Steering system:									
K Steering play - inspect	year	•		•		•		•	–
K Steering stem bearings - lubricate	2 years					•			–
Electrical system:									
Lights and switches operation - inspect	year			•		•		•	–
Headlight aiming - inspect	year			•		•		•	126

80 MAINTENANCE AND ADJUSTMENT

Frequency	Whichever comes first ↓	*Odometer Reading km × 1000 (mile × 1000)							See Page
		→	1 (0.6)	6 (3.75)	12 (7.5)	18 (11.25)	24 (15)	30 (18.75)	
Operation (Chassis Items)	Every								
Side stand switch operation - inspect	year			●		●		●	–
Engine stop switch operation - inspect	year			●		●		●	–
Chassis:									
Chassis parts - lubricate	year			●		●		●	130
Bolts and nuts tightness - inspect		●		●		●		●	–

3. Periodic Replacement

Operation (Chassis Items)	Frequency	*Odometer Reading km × 1000 (mile × 1000)					See Page
	Whichever comes first ↓ Every	1 (0.6)	12 (7.5)	24 (15)	36 (22.5)	48 (30)	
K Air cleaner element # - replace	every 18 000 km (12 000 mile)					100	
Engine oil # - change	year	●	●	●	●	●	85
K Oil filter - replace	year	●	●	●	●	●	85
K Fuel hoses - replace	5 years						–
K Coolant - change	3 years				●		95
K Radiator hoses and O-rings - replace	3 years				●		–
K Brake hoses - replace	4 years						–
K Brake fluid (front and rear) - change	2 years			●		●	110

82 MAINTENANCE AND ADJUSTMENT

Operation (Chassis Items)	Frequency	Whichever comes first → *Odometer Reading km × 1000 (mile × 1000) ↓ Every					See Page
		1 (0.6)	12 (7.5)	24 (15)	36 (22.5)	48 (30)	
K Rubber parts of master cylinder and caliper - replace	4 years					●	–
K Spark plug - replace			●	●	●	●	96

Engine Oil

In order for the engine, transmission, and clutch to function properly, maintain the engine oil at the proper level, and change the oil and replace the oil filter in accordance with the Periodic Maintenance Chart. Not only do dirt and metal particles collect in the oil, but the oil itself loses its lubricative quality if used too long.

WARNING

Motorcycle operation with insufficient, deteriorated, or contaminated engine oil will cause accelerated wear and may result in engine or transmission seizure, accident, and injury. Check the oil level before each ride and change the oil according to the periodic maintenance chart in the Owner's Manual.

Oil Level Inspection

- If the oil has just been changed, start the engine and run it for several minutes at idle speed. This fills the oil filter with oil. Stop the engine, then wait several minutes until the oil settles.

NOTICE

Racing the engine before the oil reaches every part can cause engine seizure.

- If the motorcycle has just been used, wait several minutes for all the oil to drain down.
- Check the engine oil level through the oil level inspection window. With the motorcycle held level, the oil level should come up between the upper and lower level lines next to the oil level inspection window.

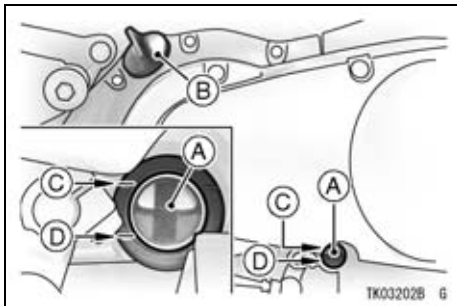

- A. Oil Level Inspection Window
- B. Oil Filler Cap
- C. Upper Level Line
- D. Low Level Line

- If the oil level is too high, remove the excess oil through the oil filler opening using a syringe or some other suitable device.
- If the oil level is too low, add the oil to reach the correct level. Use the same type and brand of oil that is already in the engine.

NOTICE

If the engine oil gets extremely low or if the oil pump does not function properly or oil passages are clogged, the warning indicator light in the speedometer will light. If this light stays on when the engine speed is above the idle speed, stop the engine immediately and find the cause.

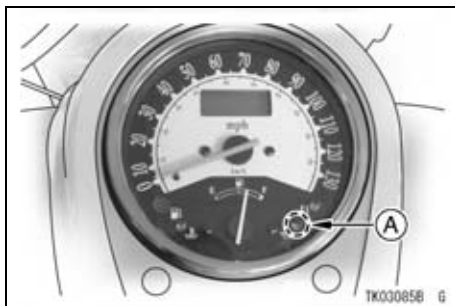

A. Oil Pressure Warning Indicator Light

Oil and/or Oil Filter Change

- Warm up the engine thoroughly, and then stop it.
- Place an oil pan beneath the engine.
- Remove the engine oil drain plug.

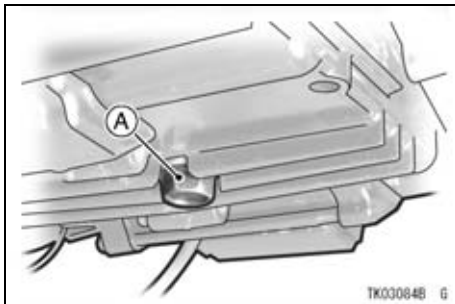

A. Engine Oil Drain Plug

- Let the oil completely drain with the motorcycle perpendicular to the ground.

⚠ WARNING

Engine oil is a toxic substance. Dispose of used oil properly. Contact your local authorities for approved disposal methods or possible recycling.

- Remove the cover.

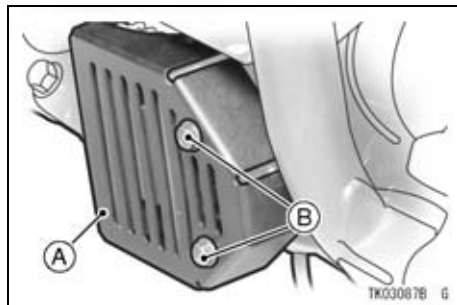

A. Cover

B. Bolt

86 MAINTENANCE AND ADJUSTMENT

- Remove the regulator/rectifier bolt.

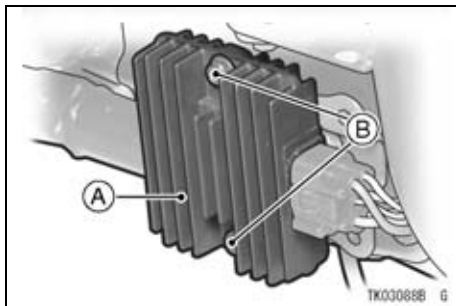

- A. Regulator/Rectifier
- B. Bolt

- Remove the bracket.

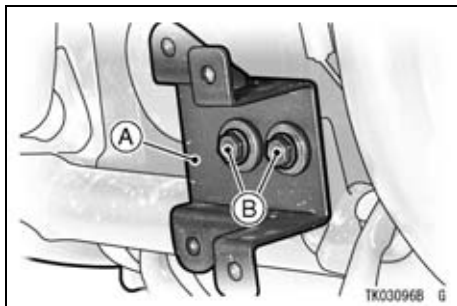

- A. Bracket
- B. Bolt

- Remove the oil filter cartridge and replace it with a new one.

NOTE

- *If a torque wrench or required Kawasaki special tool is not available, this item should be serviced by an authorized Kawasaki dealer.*

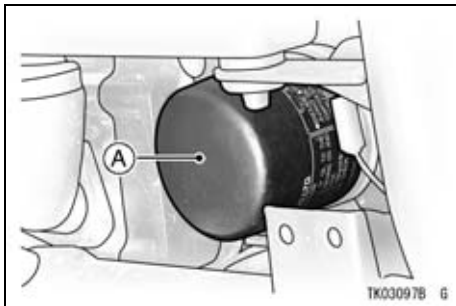

A. Cartridge

- Apply a thin film of oil to the packing and tighten the cartridge to the specified torque.

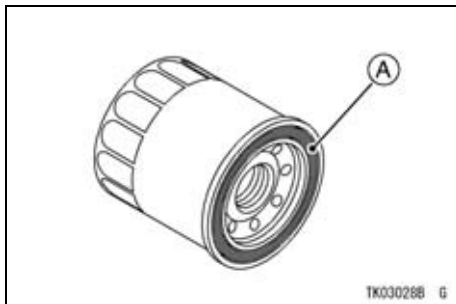

A. Packing

- Install the engine oil drain plug with a new gasket and tighten it to the specified torque.

NOTE

- *Replace any gasket with a new one.*

88 MAINTENANCE AND ADJUSTMENT

- Fill the engine up to the upper level line with a good quality engine oil specified in the table.
- Start the engine.
- Check the oil level and for oil leakage.
- Be sure to install the parts removed.

Tightening Torque

Engine Drain Plug:

20 N·m (2.0 kgf·m, 14.5 ft·lb)

Cartridge:

18 N·m (1.8 kgf·m, 13 ft·lb)

Regulator/Rectifier Bolts:

6.9 N·m (0.7 kgf·m, 61 in·lb)

Recommended Engine Oil

Type: API SG, SH, SJ, SL, or SM
with JASO MA, MA1 or MA2

Viscosity: SAE 10W-40

NOTE

- *Do not add any chemical additive to the oil. Oils fulfilling the above requirements are fully formulated and provide adequate lubrication for both the engine and the clutch.*

Engine Oil Capacity

Capacity:	3.0 L (3.2 US qt)
	[when filter is not removed]
	3.2 L (3.4 US qt)
	[when filter is removed]
	3.7 L (3.9 US qt)
	[when engine is completely dry]

Although 10W-40 engine oil is the recommended oil for most conditions, the oil viscosity may need to be changed to accommodate atmospheric conditions in your riding area.

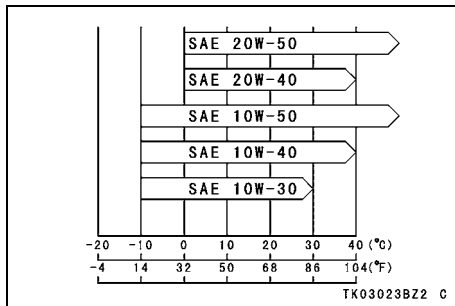

Cooling System

Radiator and Cooling Fan -

Check the radiator fins for obstruction by insects or mud. Clean off any obstructions with a stream of low-pressure water.

WARNING

The cooling fan spins at high speed and can cause serious injuries. Keep your hands and clothing away from the cooling fan blades at all times.

NOTICE

Using high-pressure water, as from a car wash facility, could damage the radiator fins and impair the radiator's effectiveness. Do not obstruct or deflect airflow through the radiator by installing unauthorized accessories in front of the radiator or behind the cooling fan. Interference with the radiator airflow can lead to overheating and consequent engine damage.

Radiator Hoses -

Check the radiator hoses for leakage, cracks or deterioration, and connections for leakage, or looseness each day before riding the motorcycle, and in accordance with the Periodic Maintenance Chart.

Coolant -

Coolant absorbs excessive heat from the engine and transfers it to the air at the radiator. If the coolant level becomes low, the engine overheats and may suffer severe damage. Check the coolant level each day before riding the motorcycle, also in accordance with the periodic maintenance chart and replenish coolant if the level is low. Change the coolant in accordance with the Periodic Maintenance Chart.

Information for Coolant

To protect the cooling system (consisting of the aluminum engine and radiator) from rust and corrosion, the use of corrosion and rust inhibitor chemicals in the coolant is essential. If coolant containing corrosion and rust inhibitor chemicals are not used, over a period of time, the cooling system

accumulates rust and scale in the water jacket and radiator. This will clog up the coolant passages, and considerably reduce the efficiency of the cooling system.

 **WARNING**

Coolant containing corrosion inhibitors for aluminum engines and radiators include harmful chemicals for human body. Drinking coolant can result in serious injury or death. Use coolant in accordance with the instructions of the manufacturer.

Soft or distilled water must be used with the antifreeze (see below for antifreeze) in the cooling system.

NOTICE

If hard water is used in the system, it causes scale accumulation in the water passages, and considerably reduces the efficiency of the cooling system.

If the lowest ambient temperature encountered falls below the freezing point of water, use permanent antifreeze in the coolant to protect the cooling system against engine and radiator freeze-up, as well as from rust and corrosion.

Use a permanent type of antifreeze (soft water and ethylene glycol plus corrosion and rust inhibitor chemicals for aluminum engines and radiators) in the cooling system. On the mixture ratio of coolant, choose the suitable one referring to the relation between freezing point and strength directed on the container.

NOTICE

Permanent types of antifreeze on the market have anti-corrosion and anti-rust properties. When it is diluted excessively, it loses its anti-corrosion property. Dilute a permanent type of antifreeze in accordance with the instructions of the manufacturer.

NOTE

- *A permanent type of antifreeze is installed in the cooling system when shipped. It is colored green and contains ethylene glycol. It is mixed at 50% and has the freezing point of -35°C (-31°F).*

Coolant Level Inspection

- Situate the motorcycle so that it is perpendicular to the ground.
- Check the coolant level through the coolant level gauge. The coolant level should be between the F (Full) and L (Low) marks.

NOTE

- *See the reservoir tank at the inside of the reservoir tank cover under the left side cover.*
- *Check the level when the engine is cold (room or atmospheric temperature).*

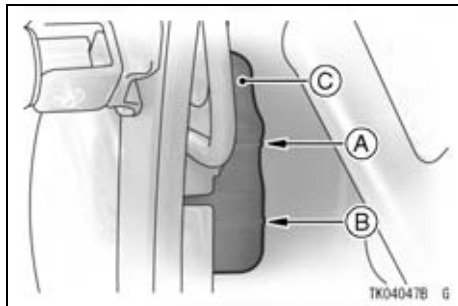

- A. F (Full) Level Line
- B. L (Low) Level Line
- C. Reserve Tank

- If the amount of coolant is insufficient, add coolant.

Coolant Filling

- Remove the seat.
- Remove the left side cover by removing the screw.

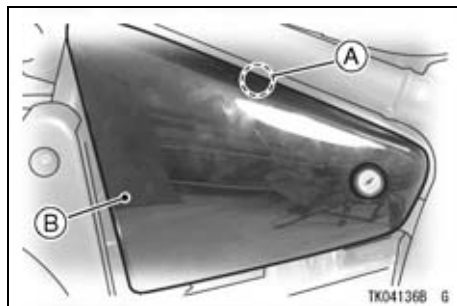

- A. Screw
- B. Left Side Cover

94 MAINTENANCE AND ADJUSTMENT

- Remove the reservoir tank cover.

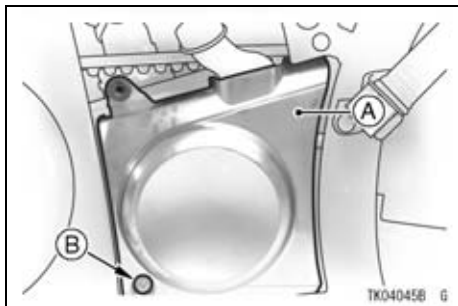

- A. Reservoir Tank Cover
- B. Bolt

- Open the cap from the reservoir tank, and add coolant through the filler opening to the F (Full) mark.

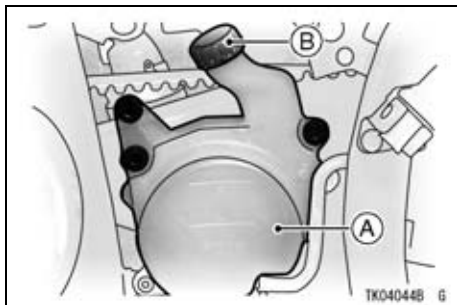

- A. Reserve Tank
- B. Reserve Tank Cap

- Install the cap after filling coolant.
- Install the parts removed.

NOTE

- When installing the left side cover, be sure to insert the projections of the left side cover to each holes.

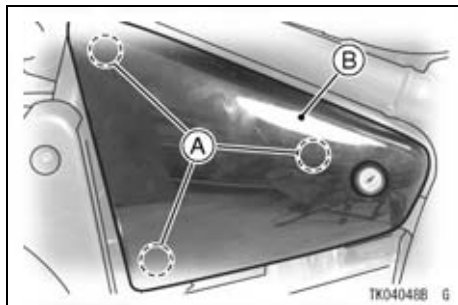

- A. Projections
- B. Left Side Cover

NOTE

- In an emergency you can add water alone to the coolant reserve tank, however it must be returned to the correct mixture ratio by the addition of antifreeze concentrate as soon as possible.

NOTICE

If coolant must be added often, or the reserve tank completely runs dry, there is probably leakage in the system. Have the cooling system inspected by your authorized Kawasaki dealer.

Coolant Change

Have the coolant changed by an authorized Kawasaki dealer.

Drive Belt

In order for the belt and belt pulleys to function properly, check the drive belt in accordance with the Periodic Maintenance Chart.

Belt check and adjustment should be done by an authorized Kawasaki dealer.

NOTICE

Improper drive belt deflection can result in belt damage.

Spark Plugs

The standard spark plug is shown in the table. The spark plugs should be replaced in accordance with the Periodic Maintenance Chart.

Spark plug removal should be done by an authorized Kawasaki dealer.

Spark Plug

Standard Plug	NGK CPR7EA-9
Plug Gap	0.8 ~ 0.9 mm (0.032 ~ 0.036 in.)
Tightening Torque	18 N·m (1.8 kgf·m, 13 ft·lb)

NOTE

- *Fit the plug cap securely onto the spark plug, and pull the cap lightly to make sure that it is properly installed.*

Evaporative Emission Control System (Southeast Asia B-1 and Thailand models only)

This system routes fuel vapors from the fuel system into the running engine or stores the vapors in a canister when the engine is stopped. Although no adjustments are required, a thorough visual inspection must be made at the intervals specified by the Periodic Maintenance Chart.

Inspection

- Check that the hoses are securely connected.
- Replace any kinked, deteriorated, or damaged hoses.

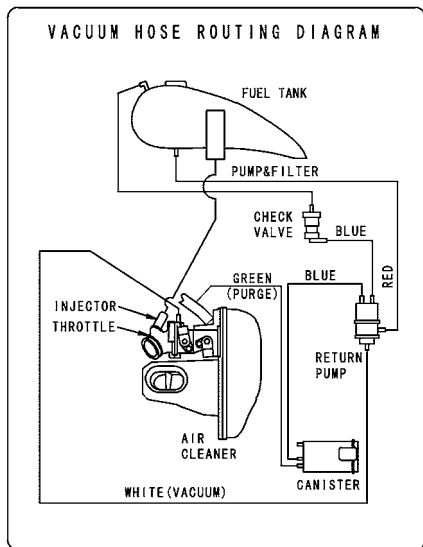

Valve Clearance

Valve and valve seat wear decreases valve clearance, upsetting valve timing.

NOTICE

If valve clearance is left unadjusted, wear will eventually cause the valves to remain partly open; which lowers performance, burns the valves and valve seats, and may cause serious engine damage.

Valve clearance for each valve should be checked and adjusted in accordance with the Periodic Maintenance Chart.

Inspection and adjustment should be done by an authorized Kawasaki dealer.

Kawasaki Clean Air System

The Kawasaki Clean Air System (KCA) is a secondary air suction system that helps the exhaust gases to burn more completely. When the spent fuel charge is released into the exhaust system, it is still hot enough to burn. The KCA System allows extra air into the exhaust system so that the spent fuel charge can continue to burn. This continued burning action tends to burn up a great deal of the normally unburned gases, as well as changing a significant portion of the carbon monoxide into carbon dioxide.

Air Suction Valves -

The air suction valve is essentially a check valve which allows fresh air to flow only from the air cleaner into the exhaust port. Any air that has passed the air suction valve is prevented from returning. Inspect the air suction valves in accordance with the Periodic Maintenance Chart. Also, inspect the air suction valves whenever stable idling cannot be obtained, engine power is greatly reduced, or there are abnormal engine noise.

Air suction valve removal and inspection should be done by an authorized Kawasaki dealer.

Air Cleaner

A clogged air cleaner restricts the engine's air intake, increasing fuel consumption, reducing engine power, and causing spark plug fouling.

The air cleaner element must be replaced in accordance with the Periodic Maintenance Chart. This motorcycle's air cleaner element consists of a wet paper filter, which can not be cleaned. In dusty, rainy, or on muddy conditions, the air cleaner element should be serviced more frequently than the recommended interval.

100 MAINTENANCE AND ADJUSTMENT

Element Removal

- Remove the bolts of the air cleaner cover located on the right-side of the engine.

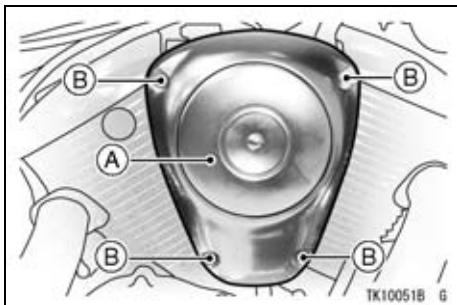

- A. Air Cleaner Cover
- B. Bolt

- Remove the air cleaner screw and the air cleaner. If any part of the element is damaged, the element must be replaced.

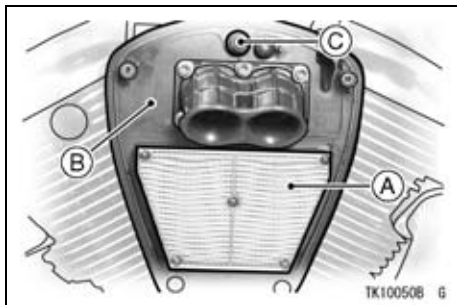

- A. Air Cleaner Element
- C. Screw
- B. Air Cleaner

 **WARNING**

If dirt or dust is allowed to pass through into the fuel injection system, the throttle may stick or become inoperable resulting in a hazardous operating condition.

NOTICE

If dirt gets through into the engine, excessive engine wear and possibly engine damage will occur.

NOTE

- *Element installation is performed in the reverse order of removal.*

Throttle Control System

Check the throttle grip play, in accordance with the Periodic Maintenance Chart, and adjust the throttle grip play.

Throttle Grip -

The throttle grip controls the butterfly valves in the throttle body. If the throttle grip has excessive play due to either cable stretch or maladjustment, it will cause a delay in throttle response, especially at low engine speed. Also, the throttle valve may not open fully at full throttle. On the other hand, if the throttle grip has no play, the throttle will be hard to control, and idle speed will be erratic.

102 MAINTENANCE AND ADJUSTMENT

Inspection

- Check that there is 2 ~ 3 mm (0.08 ~ 0.12 in.) throttle grip play when lightly turning the throttle grip back and forth.

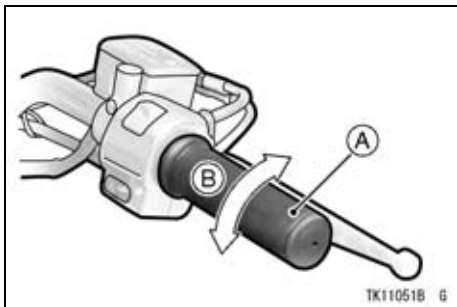

A. Throttle Grip

B. 2 ~ 3 mm (0.08 ~ 0.12 in.)

- If there is improper play, adjust it.

Adjustment

- Loosen the locknuts at the upper ends of the throttle cables, and screw

both throttle cable adjusting nuts in completely so as to give the throttle grip plenty of play.

- Turn out the decelerator cable adjusting nut until there is no play when the throttle grip is completely closed. Tighten the locknut.

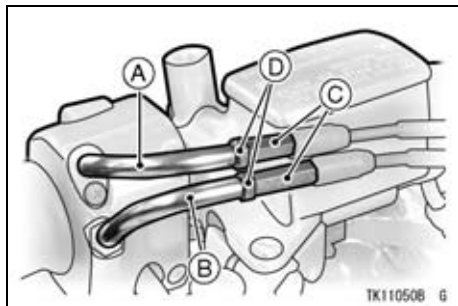

A. Accelerator Cable

B. Decelerator Cable

C. Adjusting Nuts

D. Locknuts

- Turn the accelerator cable adjusting nut until 2 ~ 3 mm (0.08 ~ 0.12 in.) of throttle grip play is obtained. Tighten the locknut.
- If the throttle cables cannot be adjusted by using the cable adjusting nuts at the upper ends of the throttle cables, further adjustment of the throttle cables should be done by an authorized Kawasaki dealer.

 **WARNING**

Operation with improperly adjusted, incorrectly routed, or damaged cables could result in an unsafe riding condition. Be sure the control cables are adjusted and routed correctly, and are free from damage.

Idle Speed

The idle adjustment should be performed in accordance with the Periodic Maintenance Chart or whenever the idle speed is disturbed.

Adjustment

- Start the engine, and warm it up thoroughly.
- Wait until the idle speed drops before making the following adjustment.
- Adjust the idle speed to 950 ~ 1 050 r/min (rpm) by turning the idle adjusting screw located at the right front cylinder.

NOTE

- *While the engine is cold, the fast idle system automatically raises the engine idling speed.*

104 MAINTENANCE AND ADJUSTMENT

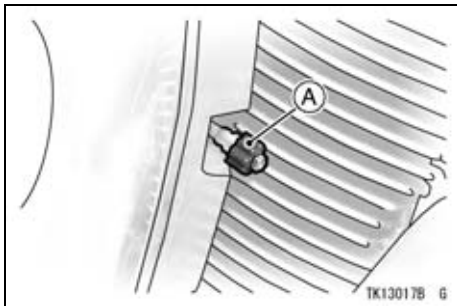

A. Idle Speed Adjusting Screw

- Open and close the throttle a few times to make sure that the idle speed does not change. Readjust if necessary.
- With the engine idling, turn the handlebar to each side. If handlebar movement changes the idle speed, the throttle cables may be improperly adjusted or incorrectly routed, or they may be damaged. Be sure to correct any of these conditions before riding.

⚠ WARNING

Operation with damaged cables could result in an unsafe riding condition. Replace damaged control cables before operation.

Clutch

Due to friction plate wear and clutch cable stretch over a long period of use, the clutch must be adjusted in accordance with the Periodic Maintenance Chart.

WARNING

The engine and exhaust system get extremely hot during normal operation and can cause serious burns. Never touch a hot engine or an exhaust pipe during clutch adjustment.

Inspection

- Check that the clutch lever has 2 ~ 3 mm (0.08 ~ 0.12 in.) of play as shown in the figure.

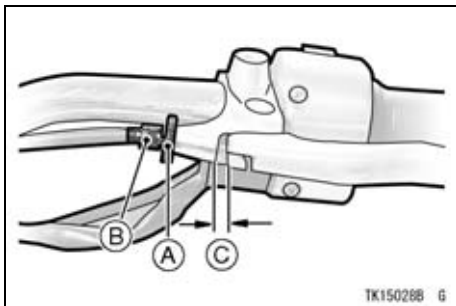

A. Locknut

B. Adjuster

C. 2 ~ 3 mm (0.08 ~ 0.12 in.)

If the play is incorrect, adjust the lever play as follows.

106 MAINTENANCE AND ADJUSTMENT

Adjustment

- Turn the adjuster so that the clutch lever will have 2 ~ 3 mm (0.08 ~ 0.12 in.) of play.

WARNING

Too much cable play can prevent clutch disengagement and cause an accident resulting in serious injury or death. When adjusting the clutch or replacing the cable, be sure the upper end of the clutch outer cable is fully seated in its fitting, or it could slip into place later, creating enough cable play to prevent clutch disengagement.

- If it cannot be done, have the clutch cable adjusted by an authorized Kawasaki dealer.

NOTE

- *After the adjustment is made, start the engine and check that the clutch does not slip and that it releases properly.*

Brakes

Brake Wear Inspection

Inspect the brakes for wear. For each front and rear disc brake caliper, if the thickness of either pad is less than 1 mm (0.04 in), replace both pads in the caliper as a set. Pad replacement should be done by an authorized Kawasaki dealer.

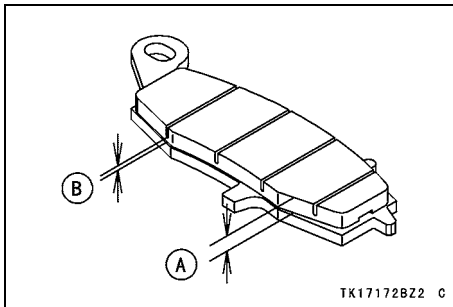

A. Lining Thickness
B. 1 mm (0.04 in.)

Disc Brake Fluid -

In accordance with the Periodic Maintenance Chart, inspect the brake fluid level in both the front and rear brake fluid reservoirs and change the brake fluid. The brake fluid should also be changed if it becomes contaminated with dirt or water.

Fluid Requirement

Use heavy-duty brake fluid only from a container marked DOT4 .

NOTICE

Do not spill brake fluid onto any painted surface.

Do not use fluid from a container that has been left open or that has been unsealed for a long time.

Check for fluid leakage around the fittings.

Check brake hose for damage.

108 MAINTENANCE AND ADJUSTMENT

Fluid Level Inspection

- The brake fluid level in the front brake fluid reservoir must be kept above the line (lower level line) next to the gauge and that in the rear brake fluid reservoir (located near the brake pedal) must be kept between the upper and lower level lines (reservoirs held horizontal).

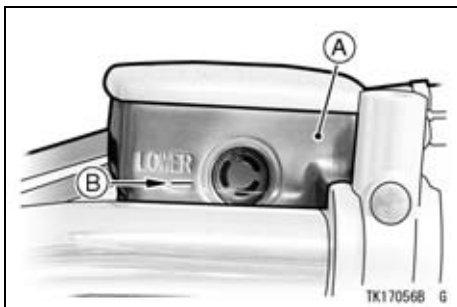

- A. Front Brake Fluid Reservoir
- B. Lower Level Line

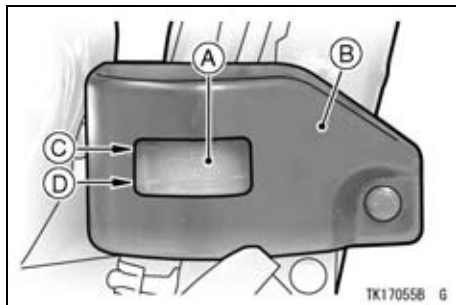

- A. Rear Brake Fluid Reservoir
- B. Cover
- C. Upper Level Line
- D. Lower Level Line

- If the fluid level in either reservoir is lower than the lower level line, check for fluid leaks in the brake lines, and fill the reservoir to the upper level line. Inside the front brake fluid reservoir is a stepped line showing the upper level line. For the rear reservoir, take off the bolt and remove the cover from the reservoir.

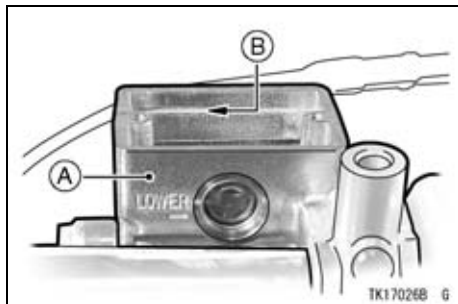

A. Front Brake Fluid Reservoir
B. Upper Level Line

⚠ WARNING

Mixing brands and types of brake fluid can reduce the brake system's effectiveness and cause an accident resulting in injury or death. Do not mix two brands of brake fluid. Change the brake fluid in the brake line completely if the brake fluid must be refilled but the type and brand of the brake fluid that is already in the reservoir are unidentified.

NOTE

- *First, tighten until slight resistance is felt indicating that the cap is seated on the reservoir body; then, tighten the cap an additional 1/6 turn while holding the brake fluid reservoir body.*



- A. Reservoir
- B. Cap
- C. Clockwise
- D. 1/6 turn

Fluid Change

Have the brake fluid changed by an authorized Kawasaki dealer.

Front and Rear Brakes -

Disc and disc pad wear is automatically compensated for and has no effect on the brake lever or pedal action. So there are no parts that require adjustment on the front and rear brakes.

▲ WARNING

Air in the brake lines diminish braking performance and can cause an accident resulting in injury or death. If the brake lever or pedal feels mushy when it is applied, there might be air in the brake lines or the brake may be defective. Have the brake checked immediately by an authorized Kawasaki dealer.

Brake Light Switches

When either the front or rear brake is applied, the brake light goes on. The front brake light switch requires no adjustment, but the rear brake light switch should be adjusted in accordance with the Periodic Maintenance Chart.

Inspection

- Turn the ignition key to “ON”.
- The brake light should go on when the front brake is applied.
- If it does not, ask your authorized Kawasaki dealer to inspect the front brake light switch.

- Check the operation of the rear brake light switch by depressing the brake pedal. The brake light should go on after about 10 mm (0.4 in.) of pedal travel.

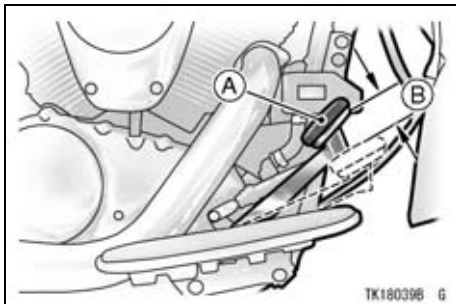

A. Brake Pedal

B. 10 mm (0.4 in.)

- If it does not, adjust the rear brake light switch.

112 MAINTENANCE AND ADJUSTMENT

Adjustment

- To adjust the rear brake light switch, move the switch up or down by turning the adjusting nut.

NOTICE

To avoid damaging the electrical connections inside the switch, be sure that the switch body does not turn during adjustment.

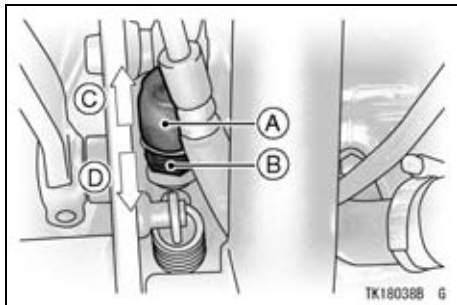

- A. Rear Brake Light Switch
- B. Adjusting Nut
- C. Lights sooner.
- D. Lights later.

Rear Shock Absorber

The rear shock absorber can be adjusted by changing the spring preload for various riding and loading conditions.

Spring Preload Adjustment

The rear shock absorber spring preload adjuster has 7 positions.

- Remove the left side cover and reservoir tank cover (see “Cooling System” section in this chapter).
- Remove the reservoir tank.

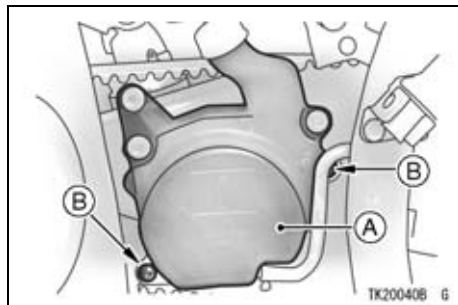

- A. Reservoir Tank
- B. Bolt

NOTE

- *When removing the reservoir tank, hook the under part of the reservoir tank to the holder of the frame as shown in the figure.*

114 MAINTENANCE AND ADJUSTMENT

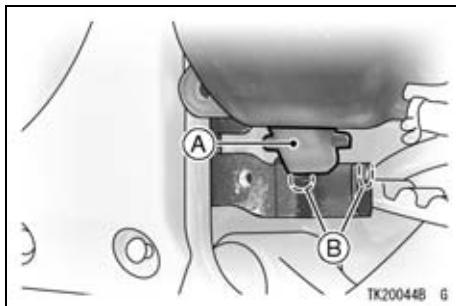

- A. Under Part of Reservoir Tank
- B. Holder

- In accordance with the following table, turn the preload adjuster with the wrench from the tool kit.

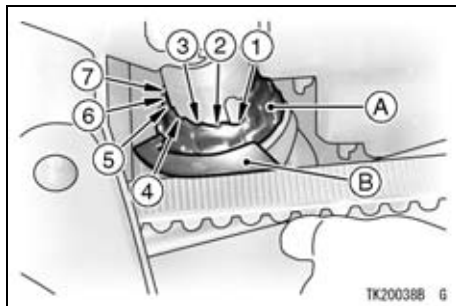

- A. Spring Preload Adjuster
- B. Wrench

Position	1	2	3	4	5	6	7	
Spring Action	←			→	Strong			

The standard setting position for an average-build rider of 68 kg (150 lb) with no passenger and no accessories is No.4.

NOTE

- *This motorcycle has two hook wrenches in the tool kit. When changing the spring preload of the rear shock absorber, turn the adjuster by using the suitable hook wrenches.*

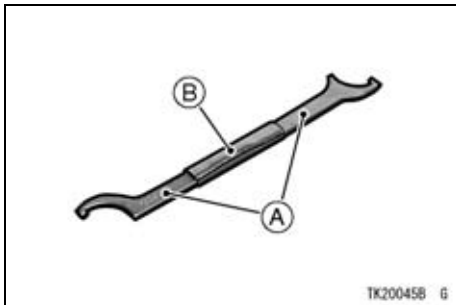

- A. Hook Wrench**
B. Extension Bar

Wheels

Tires -

Payload and Tire Pressure

Failure to maintain proper inflation pressures or observe payload limits for your tires may adversely affect handling and performance of your motorcycle and can result in loss of control. The maximum recommended load in addition to vehicle weight is 180 kg (397 lb), including rider, passenger, baggage, and accessories.

116 MAINTENANCE AND ADJUSTMENT

- Remove the air valve cap.
- Check the tire pressure often, using an accurate gauge.
- Make sure that the air valve cap is securely installed.

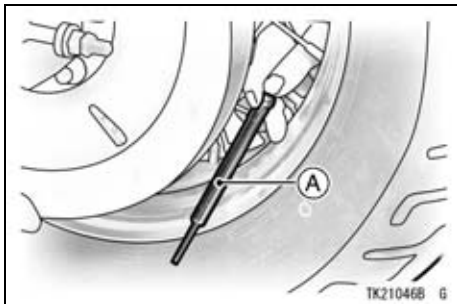

A. Tire Pressure Gauge

NOTE

- Measure the tire pressure when the tires are cold (that is, when the motorcycle has not been ridden more than a mile during the past 3 hours).
- Tire pressure is affected by changes in ambient temperature and altitude, and so the tire pressure should be checked and adjusted when your riding involves wide variations in temperature or altitude.

Tire Air Pressure (when cold)

Front	Up to 180 kg Load (397 lb)	200 kPa (2.00 kgf/cm ² , 28 psi)
Rear	Up to 97.5 kg (215 lb) load	200 kPa (2.00 kgf/cm ² , 28 psi)
	97.5 ~ 180 kg (215 ~ 397 lb) load	225 kPa (2.25 kgf/cm ² , 32 psi)

Tire Wear, Damage

As the tire tread wears down, the tire becomes more susceptible to puncture and failure. An accepted estimate is that 90% of all tire failures occur during the last 10% of tread life (90% worn). So it is false economy and unsafe to use the tires until they are bald.

- In accordance with the Periodic Maintenance Chart, measure the depth of the tread with a depth gauge, and replace any tire that has worn down to the minimum allowable tread depth.

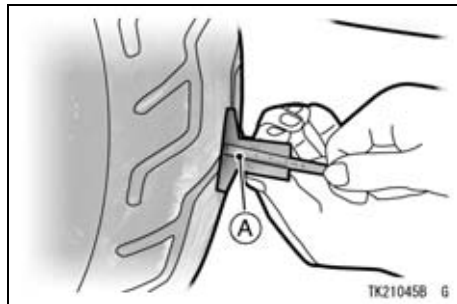

A. Tire Depth Gauge

Minimum Tread Depth

Front	_____	1 mm (0.04 in.)
Rear	Under 130 km/h (80 mph)	2 mm (0.08 in.)
	Over 130 km/h (80 mph)	3 mm (0.12 in.)

- Visually inspect the tire for cracks and cuts, replacing the tire in case of bad damage. Swelling or high spots indicate internal damage, requiring tire replacement.
- Remove any imbedded stones or other foreign particles from the tread.

NOTE

- *Have the wheel balance inspected whenever a new tire is installed.*

⚠ WARNING

Tires that have been punctured and repaired do not have the same capabilities as undamaged tires and can suddenly fail, causing an accident resulting in serious injury or death. Replace damaged tires as soon as possible. To ensure safe handling and stability, use only the recommended standard tires for replacement, inflated to the standard pressure. If it is necessary to ride on a repaired tire, do not exceed 100 km/h (60 mph) until the tire is replaced.

NOTE

- *When operating on public roadways, keep maximum speed under traffic law limits.*

- *Most counters may have their own regulations requiring a minimum tire thread depth; be sure to follow them.*

Standard Tire (Tubeless)

Front	130/90-16 M/C 67H • DUNLOP "D404FP"
Rear	180/70-15 M/C 76H • DUNLOP "D404"

WARNING

Mixing tire brands and types can adversely affect handling and cause an accident resulting in injury or death. Always use the same manufacturer's tires on both front and rear wheels.

WARNING

New tires are slippery and may cause loss of control and injury. A break-in period of 160 km (100 miles) is necessary to establish normal tire traction. During break-in, avoid sudden and maximum braking and acceleration, and hard cornering.

Battery

The battery installed in this vehicle is a sealed type, and the sealing strip should not be removed at any time after the specified electrolyte has been installed in the battery for initial service. It is not necessary to check the battery electrolyte level or add distilled water.

However, in order to maximize battery life and ensure that it will provide the power needed to start the motorcycle you must properly maintain the battery's charge. When used regularly, the charging system in the motorcycle helps keep the battery fully charged. If the motorcycle is only used occasionally or for short periods of time, the battery is more likely to discharge.

Due to their internal composition, batteries continually self discharge. The discharge rate depends on the type of battery and ambient temperature. As temperatures rise, so does the discharge rate. Every 15°C (59°F) doubles the rate.

Electrical accessories, such as digital clocks and computer memory, also draw current from the battery even when the key is switched off. Combine such "key-off" draws with hot temperature, and a battery can go from fully charged to completely discharged in a matter of days.

Self-discharge		
Temperature	Approx. Number of Days From 100% Charged to 100% discharged	
	Lead -Antimony	Lead -Calcium
	Battery	Battery
40°C (104°F)	100 Days	300 Days
25°C (77°F)	200 Days	600 Days
0°C (32°F)	550 Days	950 Days

Current Drain		
Discharging Ampere	Days from 100% Charged to 50% Discharged	Days from 100% Charged to 100% Discharged
7 mA	60 Days	119 Days
10 mA	42 Days	83 Days
15 mA	28 Days	56 Days
20 mA	21 Days	42 Days
30 mA	14 Days	28 Days

In extremely cold weather the fluid in an inadequately charged battery can easily freeze, which can crack the case and buckle the plates. A fully charged battery can withstand sub-freezing temperatures with no damage.

Battery Sulfation

A common cause of battery failure is sulfation.

Sulfation occurs when the battery is left in a discharged condition for an extended time. Sulfate is a normal by product of the chemical reactions within a battery. But when continuous discharge allows the sulfate to crystallize in the cells, the battery plates become permanently damaged and will not hold a charge. Battery failure due to sulfation is not warrantable.

Battery Maintenance

It is the owner's responsibility to keep the battery fully charged. Failure to do so can lead to battery failure and leave you stranded.

If you are riding your vehicle infrequently, inspect the battery voltage weekly using a voltmeter. If it drops below 12.6 volts, the battery should be

charged using an appropriate charger (check with your Kawasaki dealer). If you will not be using the motorcycle for longer than two weeks, the battery should be charged using an appropriate charger. Do not use an automotive-type quick charger that may overcharge the battery and damage it.

NOTE

- *Leaving the battery connected causes the electrical components (clock etc) to make the battery discharged, resulting the over discharge of the battery. In this case, the repair or replacement of the battery is not included in the warranty. If you do not drive for four weeks or more, disconnect the battery from the vehicle.*

Kawasaki-recommended chargers are
Battery Mate 150-9

OptiMate 4
 Yuasa MB-2040/2060
 Christie C10122S

If the above chargers are not available, use equivalent one.

For more details, ask your Kawasaki dealer.

Battery Charging

- Remove the battery from the motorcycle (see Battery Removal).
- Attach the leads from the charger and charge the battery at a rate (amperage × hours) that is indicated on the battery. If it is not possible to read the rate, charge the battery at an amperage that is about 1/10th of the battery capacity.
- The charger will keep the battery fully charged until you are ready to re-install the battery in the motorcycle (see Battery Installation).

NOTICE

Never remove the sealing stirp, or the battery can be damaged. Do not install a conventional battery is this vehicle, or the electrical system cannot work properly.

Make	Yuasa Battery
Type	YTX12-BS

NOTE

- *If you charge the sealed battery, never fail to observe the instructions shown on the label on the battery.*

124 MAINTENANCE AND ADJUSTMENT

Battery Removal

- Remove the seat and tool kit case (see “Jump Starting” section in the “How to Ride the Motorcycle” chapter).
- Disconnect the cables from the battery, first from the (-) terminal and then the (+) terminal.

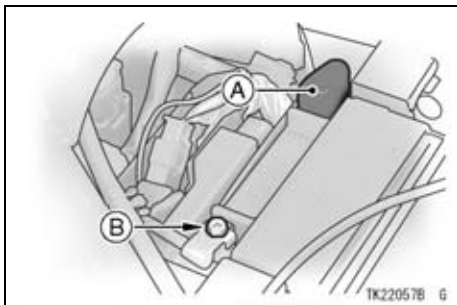

- A. (+) Terminal
- B. (-) Terminal

- Pull the battery out of the motorcycle.

- Clean the battery using a solution of baking soda and water. Be sure that the cable connections are clean.

Battery Installation

- Connect the capped (red) cable to the (+) terminal, and then connect the black cable to the (-) terminal.

NOTE

- *Install the battery in the reverse order of the Battery Removal.*

NOTICE

Installing the (-) cable to the (+) terminal of the battery or the (+) cable to the (-) terminal of the battery can seriously damage the electrical system.

- Put a light coat of grease on the terminals to prevent corrosion.

- Cover the (+) terminal with its protective cap.
- Reinstall the parts removed.

NOTE

- *When installing the seat, or tool kit case, be sure not to pinch the hose, or wires. The hose or wires should be routed as shown in the figure.*
- *After installing the tool kit case, run the seat lock cable or wire along the guide.*

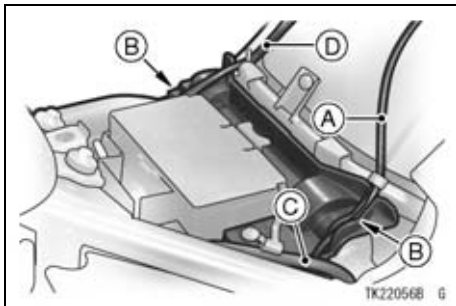

- A. Seat Lock Cable
- B. Guide
- C. Hose
- D. Wires

Headlight Beam

Horizontal Adjustment

The headlight beam is adjustable horizontally. If not properly adjusted horizontally, the beam will point to one side rather than straight ahead.

- Turn the horizontal adjusting screw on the headlight rim in or out until the beam points straight ahead.

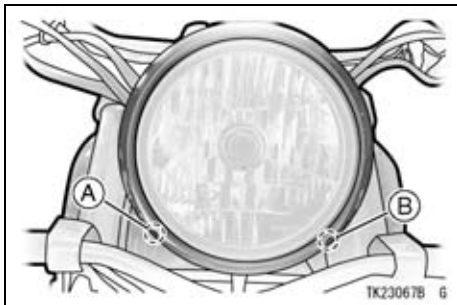

- A. Vertical Adjusting Screw
- B. Horizontal Adjusting Screw

Vertical Adjustment

The headlight beam is adjustable vertically. If adjusted too low, neither low nor high beam will illuminate the road far enough ahead. If adjusted too high, the high beam will fail to illuminate the road close ahead, and the low beam will blind oncoming drivers.

- Turn the vertical adjusting screw on the headlight rim in or out to adjust the headlight vertically.

NOTE

- *On high beam, the brightest point should be slightly below horizontal with the motorcycle on its wheels and the rider seated. Adjust the headlight to the proper angle according to local regulations.*

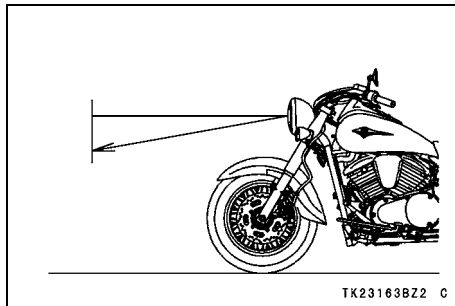

Fuses

The fuses are arranged in the fuse box located behind left side cover.

The main fuse is mounted on the starter relay behind right side cover. If a fuse fails during operation, inspect the electrical system to determine the cause, and then replace it with a new fuse of proper amperage.

128 MAINTENANCE AND ADJUSTMENT

- Remove the seat.
- Remove the left side cover (see “Cooling System” section in this chapter).

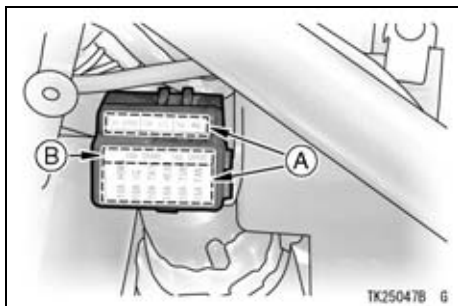

- A. Fuse Box
- B. Spare Fuse

- Remove the screw

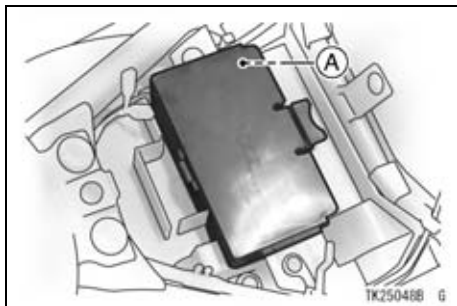

- A. Screw

- Pull out the right side cover and then inspect the main fuse.

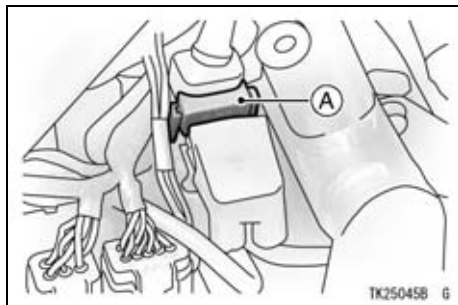

A. Main Fuse

- When installing the right side cover, be sure to insert the projections of the right side cover.

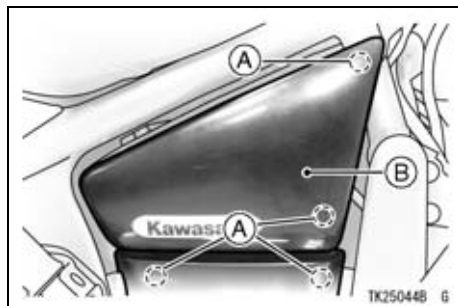

A. Projections
B. Right Side Cover

⚠ WARNING

Substituting fuses can cause wiring to overheat, catch fire and/or fail. Do not use any substitute for the standard fuse. Replace the blown fuse with a new one of the correct capacity, as specified on the junction box and main fuse.



A

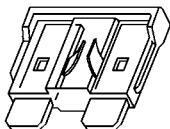

B

TK25007BZ2 C

- A. Normal**
B. Failed

General Lubrication

Lubricate the points shown below, with either motor oil or regular grease, in accordance with the Periodic Maintenance Chart or whenever the vehicle has been operated under wet or rainy conditions.

Before lubricating each part, clean off any rusty spots with rust remover and wipe off any grease, oil, dirt, or grime.

NOTE

- *A few drops of oil are effective to keep bolts and nuts from rusting and sticking. This makes removal easier. Badly rusted nuts, bolts, etc., should be replaced with new ones.*

Apply motor oil to the following pivots -

- Side Stand
- Clutch Lever
- Front Brake Lever

- Rear Brake Pedal

Lubricate the following cables with a pressure cable luber -

- (K) Clutch Inner Cables
- (K) Throttle Inner Cables

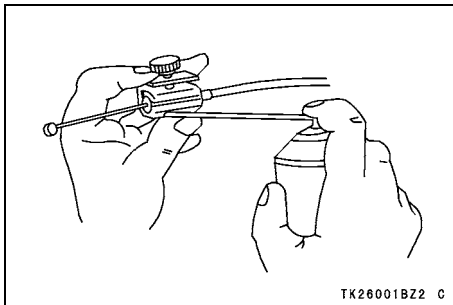

Apply grease to the following points -

- (K) Clutch Inner Cable Upper Ends
- (K) Throttle Inner Cable Upper Ends

(K): Should be serviced by an authorized Kawasaki dealer.

NOTE

- *After connecting the cables, adjust them.*

Cleaning Your Motorcycle

General Precautions

Frequent and proper care of your Kawasaki motorcycle will enhance its appearance, optimize overall performance, and extend its useful life. Covering your motorcycle with a high quality, breathable motorcycle cover will help protect its finish from harmful UV rays, pollutants, and reduce the amount of dust reaching its surfaces.

WARNING

Build-up of debris or flammable material in and around the vehicle chassis, engine, and exhaust can cause mechanical problems and increase the risk of fire.

When operating the vehicle in conditions that allow debris or flammable material to collect in and around the vehicle, inspect the engine, electrical component and exhaust areas frequently. If debris or flammable materials have collected, park the vehicle outside and stop the engine. Allow the engine to cool, then remove any collected debris. Do not park or store the vehicle in an enclosed space prior to inspecting for build-up of debris or flammable materials.

- Be sure the engine and exhaust are cool before washing.
- Avoid applying degreaser to seals, brake pads, and tires.
- Always use non-abrasive wax and cleaner/polisher.
- Avoid all harsh chemicals, solvents, detergents, and household cleaning products such as ammonia-based window cleaners.
- Gasoline, brake fluid, and coolant will damage the finish of painted and plastic surfaces: wash them off immediately.
- Avoid wire brushes, steel wool, and all other abrasive pads or brushes.
- Use care when washing the headlight lens, and the plastic parts as they can easily be scratched.
- Avoid using pressure washers; water can penetrate seals and electrical components and damage your motorcycle.

- Avoid spraying water in delicate areas such as in air intakes, fuel system, brake components, electrical components, muffler outlets, and fuel tank openings.
- After cleaning your motorcycle, check the rubber boot covering the shift pedal ball joint for correct installation. Be sure the sealing lip of the rubber boot fits into the groove of the ball joint.

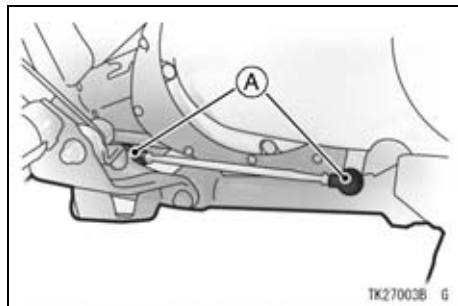

A. Rubber Boot

134 MAINTENANCE AND ADJUSTMENT

- If the boot is damaged, replace it with a new one. If the boot is not positioned in the groove correctly, replace it in the correct position.

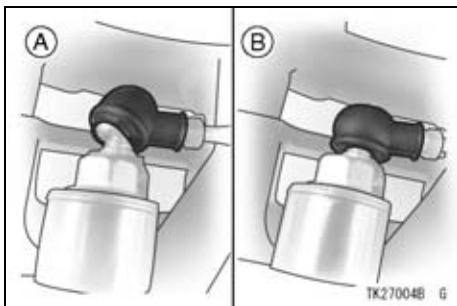

A .Not position
B. Correct position

Washing Your Motorcycle

- Rinse your bike with cold water from a garden hose to remove any loose dirt.
- Mix a mild neutral detergent (designed for motorcycles or automobiles) and water in bucket. Use a soft cloth or sponge to wash your motorcycle. If needed, use a mild degreaser to remove any oil or grease build up.
- After washing, rinse your motorcycle thoroughly with clean water to remove any residue (residue from the detergent can damage parts of your motorcycle).
- Use a soft cloth to dry your motorcycle. As you dry, inspect your motorcycle for chips and scratches. Do not let the water air dry as this can damage the painted surfaces.

- Start the engine and let it idle for several minutes. The heat from the engine will help dry moist areas.
- Carefully ride your motorcycle at a slow speed and apply the brakes several times. This helps dry the brakes and restores them to normal operating performance.

NOTE

- *After riding in an area where the roads are salted or near the ocean, immediately wash your motorcycle with cold water. Do not use warm water as it accelerates the chemical reaction of the salt. After drying, apply a corrosion protection spray on all metal and chrome surfaces to prevent corrosion.*

- *Condensation may form on the inside of the headlight lens after riding in the rain, washing the motorcycle or humid weather. To remove the moisture, start the engine and turn on the headlight. Gradually the condensation on the inside of the lens will clear off.*

Semi-gloss Finish

To clean the semi-gloss finish;

- When washing the motorcycle, always use a mild neutral detergent and water.
- The semi-gloss finish effect may be lost when the finish is excessively rubbed.
- If any doubt, consult an authorized Kawasaki dealer.

Painted Surfaces

After washing your motorcycle, coat painted surfaces, both metal and plastic, with a commercially available motorcycle/automotive wax. Wax should be applied once every three months or as conditions require. Avoid surfaces with “satin” or “flat” finishes. Always use nonabrasive products and apply them according to the instructions on the container.

Plastic Parts

After washing use a soft cloth to gently dry plastic parts. When dry, treat the headlight lens and non-painted plastic parts with an approved plastic cleaner/polisher product.

NOTICE

Plastic parts may deteriorate and break if they come in contact with chemical substances or household cleaning products such as gasoline, brake fluid, window cleaners, thread-locking agents, or other harsh chemicals. If a plastic part comes in contact with any harsh chemical substance, wash it off immediately with water and a mild neutral detergent, and then inspect for damage. Avoid using abrasive pads or brushes to clean plastic parts, as they will damage the part's finish.

Chrome and Aluminum

Chrome and uncoated aluminum parts can be treated with a chrome/aluminum polish. Coated aluminum should be washed with a mild neutral detergent and finished with a spray polish. Aluminum wheels, both painted and unpainted can be cleaned with special non-acid based wheel spray cleaners.

Leather, Vinyl, and Rubber

If your motorcycle has leather accessories, special care must be taken. Use a leather cleaner/treatment to clean and care for leather accessories. Washing leather parts with detergent and water will damage them, shortening their life.

Vinyl parts should be washed with the rest of the motorcycle, then treated with a vinyl treatment.

The sidewalls of tires and other rubber components should be treated with a rubber protectant to help prolong their useful life.

 **WARNING**

Rubber protectants can be slippery and, if used on the tread area, cause loss of traction resulting in accident causing injury or death. Do not apply rubber protectant to any tread area.

STORAGE

Preparation for Storage:

- Clean the entire vehicle thoroughly.
- Run the engine for about five minutes to warm the oil, shut it off and drain the engine oil.



WARNING

Engine oil is a toxic substance. Dispose of used oil properly. Contact your local authorities for approved disposal methods or possible recycling.

- Put in fresh engine oil.
- Empty the fuel from the fuel tank by the pump or siphon.

 **WARNING**

Gasoline is extremely flammable and can be explosive under certain conditions, creating the potential for serious burns. Turn the ignition key to “OFF”. Do not smoke. Make sure the area is well-ventilated and free from any source of flame or sparks; this includes any appliance with a pilot light. Gasoline is a toxic substance. Dispose of gasoline properly. Contact your local authorities for approved disposal methods.

- Empty the fuel system by running the engine at idle speed until all fuel in the fuel system is used up (If left in for a long time, the fuel will break down and clog the fuel system).

 **WARNING**

An air/oil mist may be forcibly ejected from the spark plug holes and could get into your eyes. Do not lean over the engine when performing this procedure. If you do get oil in your eyes, wash them immediately with liberal amounts of clean, fresh water and consult a physician as soon as possible.

- Reduce tire pressure by about 20%.

140 STORAGE

- Set the motorcycle on a box or stand so that both wheels are raised off the ground. (If this cannot be done, put boards under the front and rear wheels to keep dampness away from the tire rubber.)
- Spray oil on all unpainted metal surfaces to prevent rusting. Avoid getting oil on rubber parts or in the brakes.
- Lubricate all the cables.
- Remove the battery, and store it where it will not be exposed to direct sunlight, moisture, or freezing temperatures. During storage it should be given a slow charge (one ampere or less) about once a month. Keep the battery well charged especially during cold weather.
- Tie plastic bags over the mufflers to prevent moisture from entering.
- Put a cover over the motorcycle to keep dust and dirt from collecting on it.

Preparation after Storage:

- Remove the plastic bags from the mufflers.
- Install the battery in the motorcycle and charge the battery if necessary.
- Fill the fuel tank with fuel.
- Check all the points listed in the Daily Checks section.
- Lubricate the pivots, bolts and nuts.

OWNER SATISFACTION

(For Products Sold in Australia Only)

Your satisfaction is important to your authorized Kawasaki dealer and to Kawasaki Motors Pty., Ltd. If you have a problem concerning warranty or service, please take the following action:

Contact the owner and/or service manager of your authorized Kawasaki dealer. Fully explain your problem and ask for assistance in resolving the situation. The OWNER of the dealership is an independent business person and is concerned with your satisfaction and your future business. For this reason the owner is in the best position to assist you. Also, all warranty and service matters are handled and resolved through the authorized Kawasaki dealer network.

If you are unsatisfied after working with your Kawasaki dealer and feel you still require further assistance, WRITE to the address below. Please be certain to provide the model, product identification number, mileage or hours of use, accessories, dates that events occurred and what action has been taken by both you and your dealer. Include the name and address of the dealership. To assist us in resolving your inquiry, please include copies of related receipts and any other pertinent information including the names of the dealership personnel with whom you have been working in the resolution of your problem.

142 OWNER SATISFACTION

Upon receipt of your WRITTEN correspondence we will contact the dealership and work with them in resolving your problem.

In order to provide a permanent record, all warranty and service resolutions take place only through WRITTEN correspondence.

Please send your correspondence to:

Customer Relations:

Technical Services Department
KAWASAKI MOTORS Pty., Ltd.
LOCKED BAG 802,
ERMINGTON. NSW. 1700.
A.C.N. 002 840 315.
E-mail: info@Kawasaki.com.au

ENVIRONMENTAL PROTECTION

To help preserve the environment, properly discard used batteries, tires, oils and fluids, or other vehicle components that you might dispose of in the future. Consult your authorized Kawasaki dealer or local environmental waste agency for their proper disposal procedure. This also applies to disposal of the entire vehicle at the end of its life.

LOCATION OF LABELS

All warning labels which are on your vehicle are repeated here. Read labels on your vehicle and understand them thoroughly. They contain information which is important for your safety and the safety of anyone else who may operate your vehicle. Therefore, it is very important that all warning labels be on your vehicle in the locations shown. If any label is missing, damaged, or worn, get a replacement from your Kawasaki dealer and install it in the correct position.

NOTE

○ *The sample warning labels in this section have part numbers to help you and your dealer obtain the correct replacement.*

○ *Refer to the actual vehicle label for model specific data grayed out in the illustration.*

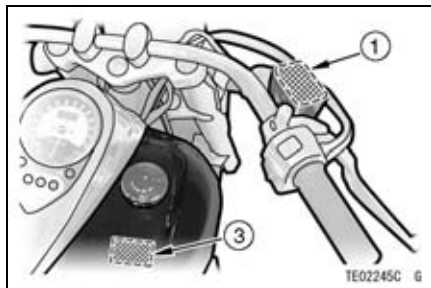

1. Brake Fluid (Front)
*3. Fuel Level

* only on Southeast Asia B1 and Thailand models

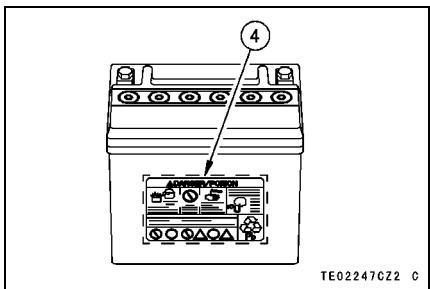
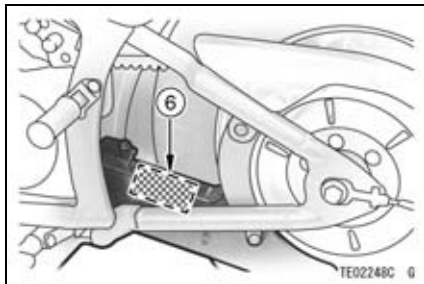
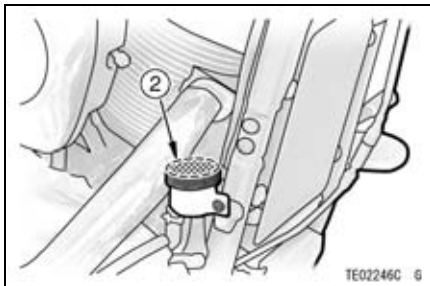

- 2. Brake Fluid (Rear)
- 4. Battery Position/Danger
- 6. Tire and Load Data

146 LOCATION OF LABELS

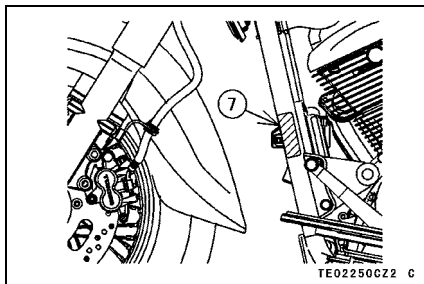
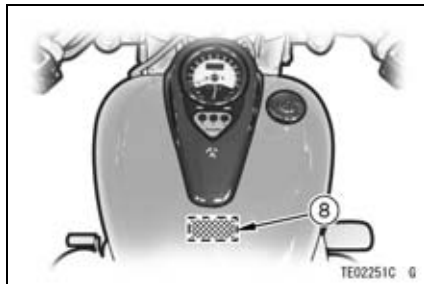
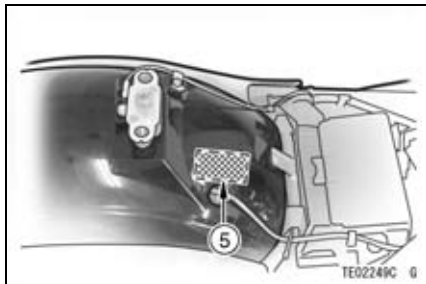

- *5. Vacuum Hose Routing Diagram**
- **7. Stationary Noise Test Information**
- ***8. Helmet**

- * only on Southeast Asia B1 and Thailand models**
- ** only on Australia model**
- *** only on Thailand model**

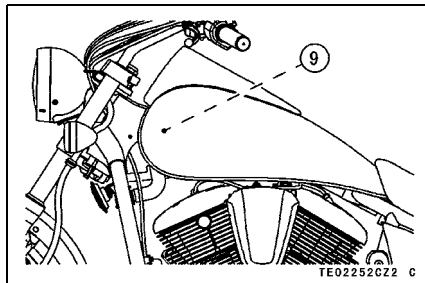

9. Radiator Cap Danger

148 LOCATION OF LABELS

(1)/(2)

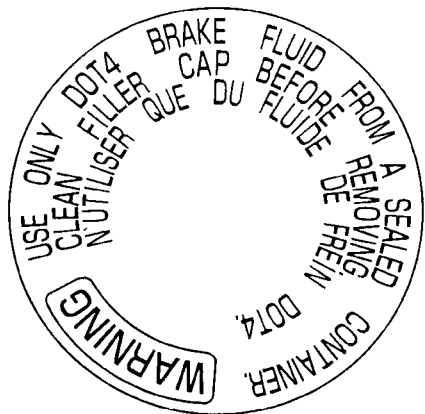



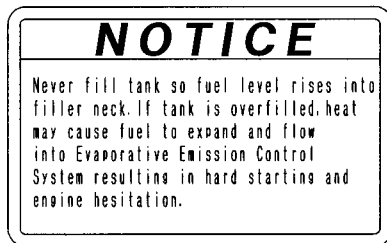









(3) only on Southeast Asia B1 and Thailand models



56071-0158

TE03715D S

(4)

⚠ DANGER/POISON					
					
SHIELD EYES EXPLOSIVE GASES CAN CAUSE BLINDNESS OR INJURY!	NO <ul style="list-style-type: none"> • SPARKS • FLAMES • SMOKING 	SULFURIC ACID CAN CAUSE BLINDNESS OR SEVERE BURNS	FLUSH EYES IMMEDIATELY WITH WATER  GET MEDICAL HELP FAST		
KEEP OUT OF REACH OF CHILDREN					
IN U.S.A., YUASA BATTERY, INC. SERVICED BY : READING, PA. 19605		 LEAD RETURN RECYCLE Pb			
					

150 LOCATION OF LABELS

(5) only on Southeast Asia B1 and Thailand models

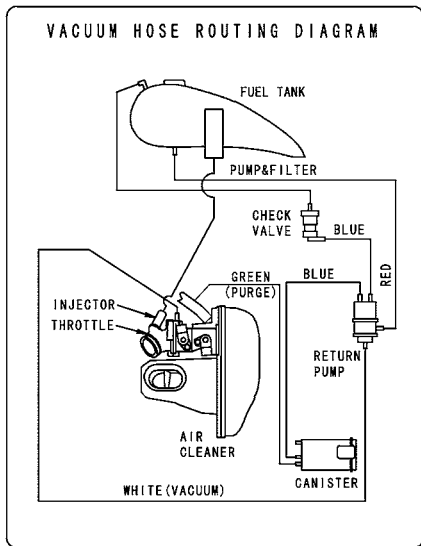

TE03469BN7 C

(6)

TIRE AND LOAD DATA						
The stability and handling characteristics of this motorcycle could become unsafe by the use of improper tire inflation pressures, overworn tires, unsuitable replacement tires, or overloading. When tire tread wears down to the limit, replace the tire with only the standard tire. Maintain the inflation pressure specified.						
	Air Pressure(Cold)		Size & Make Type		Minimum Tread Depth	
Front	Up to 180kg Load (397lbs)	200 kPa (2.00kgf/cm ² , 28psi)	DUNLOP 130/90-16M/C 67H D404FP		1 mm(0.04in)	
Rear	Up to 97.5kg Load (215lbs)	200 kPa (2.00kgf/cm ² , 28psi)	DUNLOP 180/70-15M/C 76H D404		Up to 130 km/h(80MPH)	2 mm(0.08in)
	97.5-180 kg Load (215-397lbs)	225 kPa (2.25kgf/cm ² , 32psi)			Over 130 km/h(80MPH)	3 mm(0.12in)

56053-0176

TE03971C S

152 LOCATION OF LABELS

(6) only on Australia model

TIRE AND LOAD DATA

The stability and handling characteristics of this motorcycle could become unsafe by the use of improper tire inflation pressures, worn tires, unsuitable replacement tires, or overloading. When tire tread wears down to the limit, replace the tire with only the standard tire. Maintain the inflation pressure specified.

	Air Pressure(Cold)		Size & Make Type		Minimum Tread Depth	
Front	Up to 180kg Load (397lbs)	200 kPa (2.00kgf/cm ² , 28psi)	DUNLOP 130/90-16M/C 67H D404FP	BRIDGESTONE 130/90-16M/C 67H G721	1 mm(0.04in)	
Rear	Up to 87.5kg Load (215lbs)	200 kPa (2.00kgf/cm ² , 28psi)	DUNLOP 180/70-15M/C 76H D404	BRIDGESTONE 180/70-15M/C 76H G722	Up to 130 km/h(80MPH)	2 mm(0.08in)
	97.4-180 kg Load (215-387lbs)	225 kPa (2.25kgf/cm ² , 32psi)			Over 130 km/h(80MPH)	3 mm(0.12in)

56053-0513

TE03970C S

VN900BF



Kawasaki Heavy Industries, Ltd. Motorcycle & Engine Company

Printed in Japan

