



YAMAHA

XT250W

OWNER'S MANUAL

3MG-28199-20

IDENTIFICATION NUMBERS RECORD

1. KEY NUMBER:

2. VEHICLE NUMBER:

3. ENGINE NUMBER:

Your key identification number is stamped on your key as shown in the following illustration. Record this number in the space provided for reference if you need a new key.

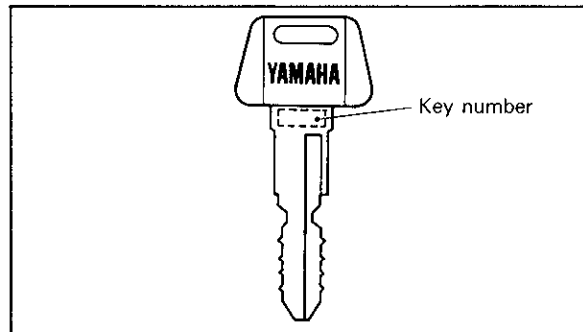

Record your vehicle and engine numbers in the spaces provided to assist you in ordering spare parts from your Yamaha dealer or for reference in case your vehicle is stolen. (See page 2-1)

XT250W

OWNER'S MANUAL

©1988 by Yamaha Motor Co., Ltd.

1st Edition, August 1988

**All rights reserved. Any reprinting or
unauthorized use without the written
permission of Yamaha Motor Co., Ltd.
is expressly prohibited.**

Printed in Japan

INTRODUCTION

Congratulations on your purchase of the Yamaha XT250W. This model is the result of Yamaha's vast experience in the production of sporting, touring, and pacesetter racing machines. It represents the high degree of craftsmanship and reliability that have made Yamaha a leader in these fields.

This manual will give you an understanding of the operation, inspection, and basic maintenance of this motorcycle. If you have any questions about the operation or maintenance of your motorcycle, please consult a Yamaha dealer.

NOTE: _____

Some data in this manual may become outdated due to future improvement on this model. If you have any questions about this manual or your motorcycle, please consult a Yamaha dealer.

**TECHNICAL PUBLICATIONS
SERVICE DIVISION
MOTORCYCLE GROUP
YAMAHA MOTOR CO., LTD.**

⚠ WARNING: _____

PLEASE READ THIS MANUAL CAREFULLY AND COMPLETELY BEFORE OPERATING THIS MOTORCYCLE.

Particularly important information is distinguished in this manual by the following notations:

NOTE:

A NOTE provides key information to make procedures easier or clearer.

⚠ CAUTION:

A CAUTION indicates special procedures that must be followed to avoid damage to the motorcycle.

⚠ WARNING:

A WARNING indicates special procedures that must be followed to avoid injury to a motorcycle operator or person inspecting or repairing the motorcycle.

NOTE: _____

This manual should be considered a permanent part of this motorcycle and should remain with it even if the motorcycle is subsequently sold.

⚠️ THINK OF YOUR SAFETY:

Both motorcycles and mopeds are fascinating vehicles which give a tremendous feeling of freedom to their riders.

They must be correctly maintained at all times in order to ensure optimum performance. However, as a rider you must also ensure that your physical condition is good, and that you are not tired, in order that you too can optimize your vehicle control.

Medicines, drugs and alcohol should not be combined with riding, especially alcohol which increases the individual's likelihood of taking risks.

Alcohol is dangerous, even in small quantities.

Correct protective riding gear is just as much a part of motorcycling safety as the safety belt is in the car; a good leather suit and gloves, sturdy boots and a good quality, properly fitting crash helmet are ideal. But beware: good protective clothing can result in the individual being lulled into a false sense of security. When this happens more risks are taken and speeds increase... this particularly applies in wet weather.

The good motorcyclist therefore rides defensively and protectively in order to minimize risks.

CONTENTS

DESCRIPTION	1-1
MOTORCYCLE IDENTIFICATION	2-1
Vehicle identification number	2-1
Engine serial number	2-1
CONTROL FUNCTIONS	3-1
Main switch	3-1
Indicator lights	3-2
Speedometer	3-2
Tachometer	3-3
Handlebar switches	3-3
Clutch lever	3-4
Change pedal	3-4
Front brake lever	3-5
Rear brake pedal	3-5
Fuel cock	3-5
Starter lever (CHOKE)	3-6
Steering lock	3-6
Helmet holder	3-7
Kick starter	3-8
Sidestand	3-8
Sidestand switch operation check	3-9

PRE-OPERATION CHECKS	4-1
Brakes	4-2
Clutch	4-2
Throttle grip	4-2
Engine oil	4-2
Drive chain	4-2
Tires	4-3
Wheels	4-5
Lights and signals	4-6
Fuel	4-6
OPERATION AND IMPORTANT	
RIDING POINTS	5-1
Starting a cold engine	5-1
Starting a warm engine	5-3
Warming up	5-3
Engine break-in	5-4
Parking	5-4
PERIODIC MAINTENANCE AND	
MINOR REPAIR	6-1
Tool kit	6-1
PERIODIC MAINTENANCE/ LUBRICATION	6-3

Torque specifications	6-5	Lubrication of levers, pedals etc.	6-22
Engine oil	6-6	Front fork inspection	6-22
Air filter	6-9	Steering inspection	6-23
Carburetor adjustment	6-10	Wheel bearings	6-24
Idle speed adjustment	6-11	Battery	6-24
Throttle cable adjustment	6-12	Replenishing the battery fluid	6-25
Cam chain adjustment	6-13	Circuit breaker	6-26
Valve clearance adjustment	6-13	Replacing the headlight and tail/brake light bulb	6-27
Decompression cable adjustment	6-13	Rear shock	6-27
Spark plug inspection	6-13	Front wheel removal	6-28
Front brake adjustment	6-15	Front wheel installation	6-29
Rear brake adjustment	6-16	Rear wheel removal	6-30
Checking the brake shoes (Front brake)	6-17	Rear wheel installation	6-31
Brake lining inspection (Rear brake)	6-17	Troubleshooting	6-32
Brake light switch adjustment	6-18	Troubleshooting chart	6-33
Clutch adjustment	6-18	CLEANING AND STORAGE	7-1
Drive chain slack check	6-19	A. Cleaning	7-1
Drive chain slack adjustment	6-20	B. Storage	7-2
Drive chain lubrication	6-21	SPECIFICATIONS	8-1
Cable inspection and lubrication	6-22	NOISE REGULATION (For Australia)	9-1
		WIRING DIAGRAM	

DESCRIPTION

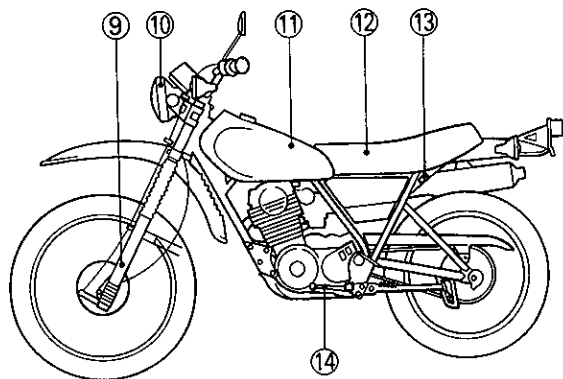
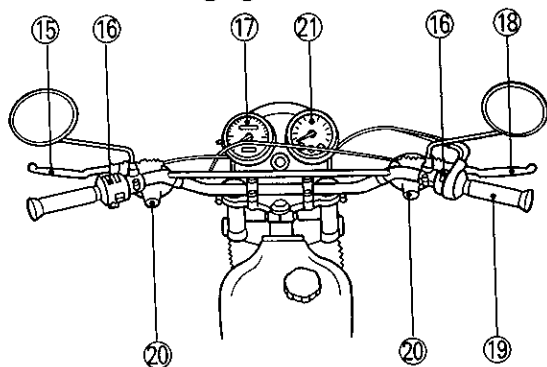
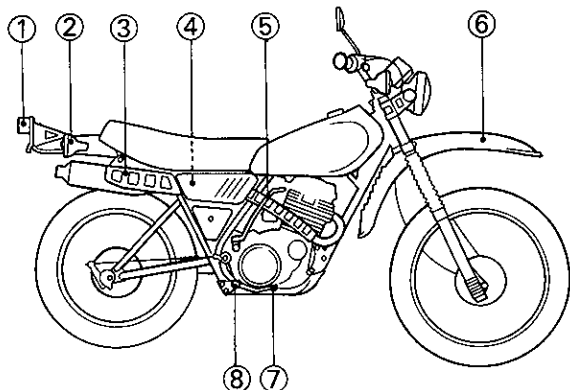

- | | | | |
|----|---------------------|----|---------------------|
| 1 | Taillight | 12 | Seat |
| 2 | Rear flasher light | 13 | Helmet holder |
| 3 | Silencer | 14 | Change pedal |
| 4 | Rear shock absorber | 15 | Clutch lever |
| 5 | Kick crank | 16 | Handlebar switch |
| 6 | Front fender | 17 | Speedometer |
| 7 | Brake pedal | 18 | Brake lever |
| 8 | Footrest | 19 | Throttle grip |
| 9 | Front fork | 20 | Front flasher light |
| 10 | Headlight | 21 | Tachometer |
| 11 | Fuel tank | | |

NOTE:

The motorcycle you have purchased may differ slightly from those shown in the photographs.

MOTORCYCLE IDENTIFICATION

Vehicle identification number

The vehicle identification number is stamped into the steering head pipe.

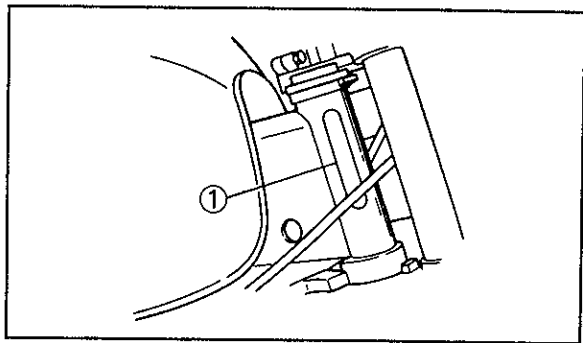

1 Vehicle identification number

NOTE:

The vehicle identification number is used to identify your motorcycle and may be used to register your motorcycle with the licensing authority in your state.

Engine serial number

The engine serial number is stamped into the right side of the engine.

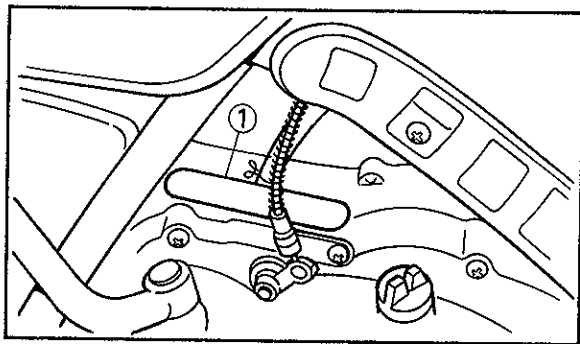

1 Engine serial number

NOTE:

The first three digits of these numbers are for model identification; the remaining digits are the unit production number. Keep a record of these numbers for reference when ordering parts from a Yamaha dealer.

CONTROL FUNCTIONS

Main switch

Functions of the respective switch positions are as follows:

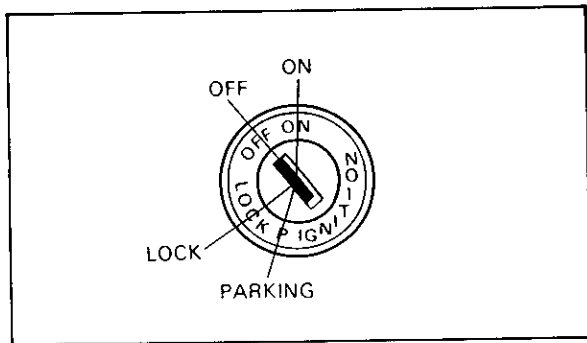

ON:

Electrical circuits are switched on. The engine can be started. The key cannot be removed in this position.

OFF:

All electrical circuits are switched off. The key can be removed in this position.

LOCK:

The steering is locked in this position, and all electrical circuits are switched off. The key can be removed in this position. Refer to "Steering lock" (Page 3-6) for proper operation.

PARKING:

The steering is locked in this position, and the taillight and auxiliary light come on but all other circuits are off. The key can be removed in this position.

NOTE:

Always turn the main switch to "OFF" or "LOCK" position and remove the key when motorcycle is unattended.

Indicator lights

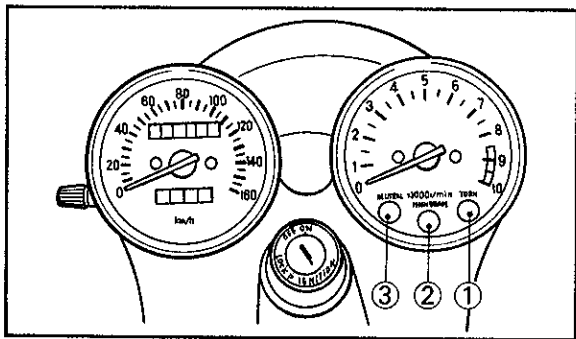

- 1 "TURN" indicator light
- 2 "HIGH BEAM" indicator
- 3 "NEUTRAL" indicator light

"TURN" indicator light (orange):

This indicator flashes when the flasher switch is "ON".

"HIGH BEAM" indicator (blue):

This indicator lights when the headlight high beam is used.

"NEUTRAL" indicator light (green)"

This indicator lights when the transmission is in neutral.

Speedometer

The odometer and trip odometer are built into the speedometer. The trip odometer can be reset to "0" with the reset knob

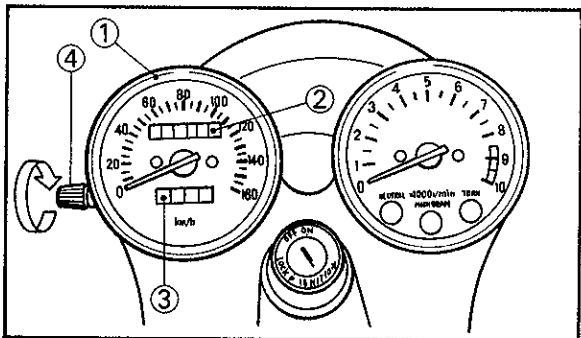

- 1 Speedometer
- 2 Odometer
- 3 Trip odometer
- 4 Reset knob

Tachometer

The tachometer is provided so the rider can keep the engine speed within the ideal power range

Do not operate in the red zone.
Red zone: 8,500 r/min and above

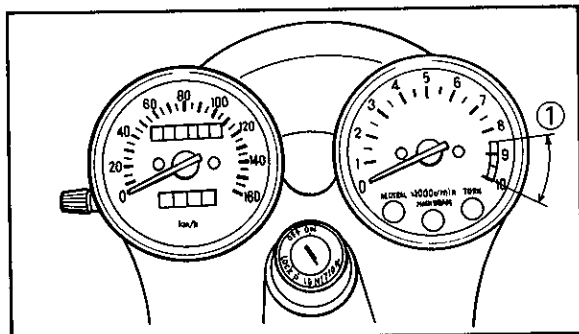

1 Red zone

Handlebar switches: "ENGINE STOP" switch

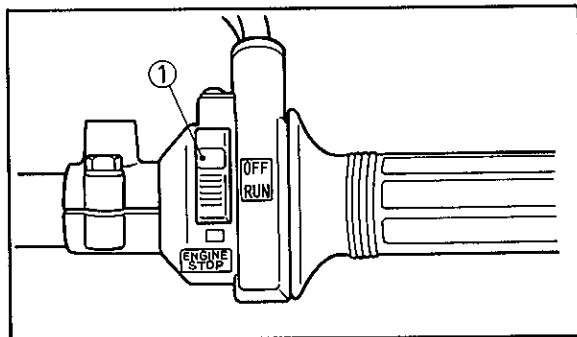

1 "ENGINE STOP" switch

Make sure that the engine stop switch is on "RUN". The engine switch has been equipped to ensure safety in an emergency such as when the motorcycle is upset or trouble takes place in the throttle system. The engine will not start when the engine switch is turned to "OFF".

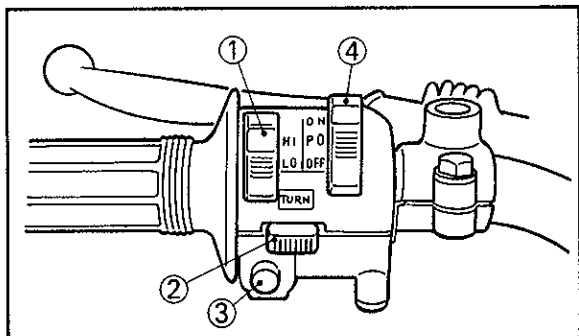

- | | |
|----------------------------|-------------------|
| 1 "LIGHTS" (Dimmer) switch | 2 "TURN" switch |
| 3 "HORN" switch | 4 "LIGHTS" switch |

"LIGHTS" (Dimmer) switch

Turn to the "HI" for the high beam and to the "LO" for the low beam.

"TURN" switch

This is a three-way switch: the center position is off; turn to the "L" for the left flasher and to the "R" for the right flasher.

"HORN" switch

Press the switch to sound the horn.

"LIGHTS" switch

Turn the light switch to the "PO" to turn on the auxiliary light, the taillight and the meter lights. And then, turn the light switch to the "ON" to turn on the headlight, the auxiliary light, the taillight and meter lights.

Clutch lever

The clutch lever is located on the left handlebar and disengages or engages the clutch. Pull the clutch lever to the handlebar to disengage the clutch and release the lever to engage the clutch. The lever should be pulled rapidly and released slowly for smooth starts.

Change pedal

The gear ratios of the constant-mesh 5-speed transmission are ideally spaced. The gears can be shifted by using the change pedal on the left side of the engine. Refer to the illustration for the gear shifting pattern.

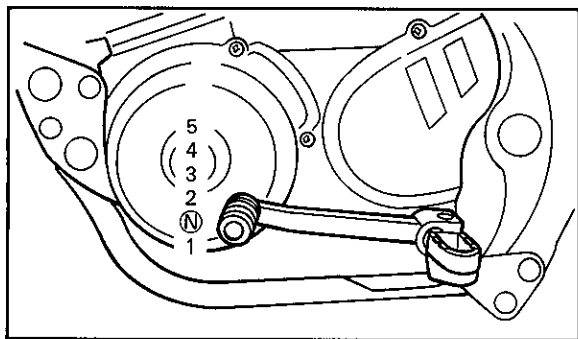

Ⓝ Neutral

Front brake lever

The front brake lever is located on the right handlebar. Pull it toward the handlebar to activate the front brake.

Rear brake pedal

The rear brake pedal is on the right side of the motorcycle and activates the rear brake through a link rod.

Fuel cock

The fuel cock function to supply fuel from the tank to the carburetor and also to filter the fuel.

The fuel cock has the following three positions:

- OFF:** With the lever in this position fuel will not flow. Return the lever to this position when the engine is not running.
- ON:** With the lever in this position fuel flows to the carburetor. Normal riding is done with the lever in this position.
- RES.** This indicates reserve. If you run out of fuel while riding, move the lever to this position. Then, fill the tank at the first opportunity.

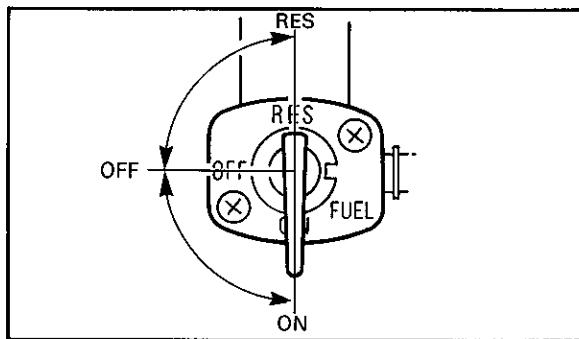

Starter lever (CHOKE)

When cold the engine requires a richer fuel mixture for starting. A separate starter circuit, which is controlled by the starter lever, supplies this mixture.

Push the lever down to open the circuit (for starting) and pull it up to close the circuit.

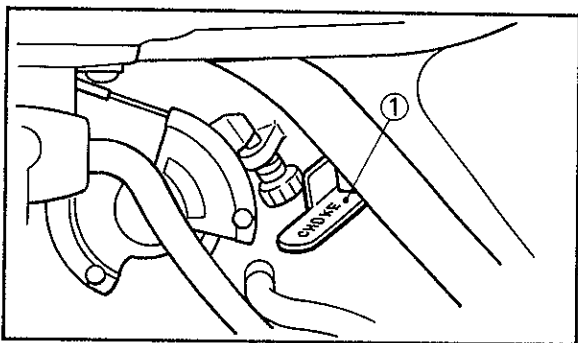

1 Starter lever

Steering lock

The steering is locked when the main switch is in the "LOCK". To lock the steering, turn the handlebars fully to the right or left. Give one push to the key at the "OFF" position; then turn it counterclockwise to the "LOCK" and remove the key. To release the lock, only turn the key clockwise.

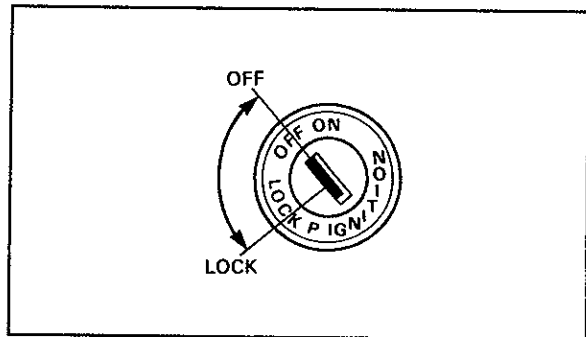

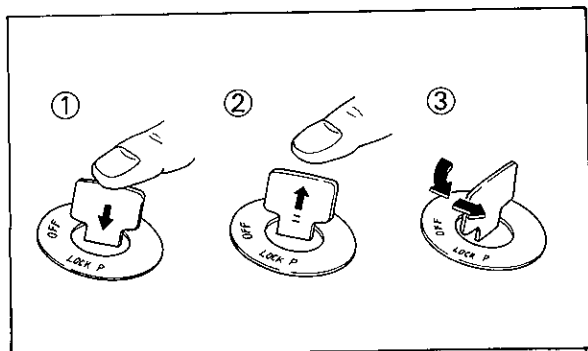

1 Push

2 Release

3 Turn

⚠ WARNING:

Never turn the key to "LOCK" when the motorcycle is moving.

Helmet holder

To open the helmet holder, insert the key in the lock and turn it clockwise. To lock the helmet holder, reverse the above steps.

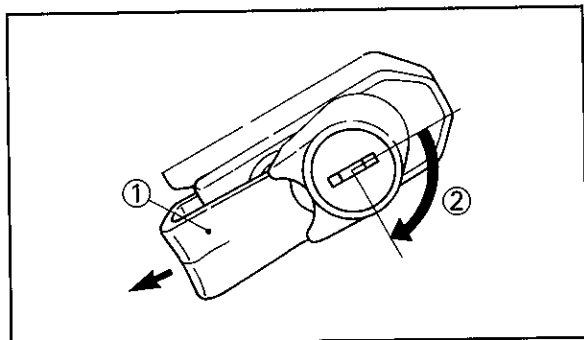

1 Helmet holder

2 Open

⚠ WARNING:

Never ride with a helmet in the helmet holder. It could interfere with rear wheel movement, causing loss of control and possibly an accident.

Kick starter

The kick starter is located on the right, rear side of the engine. To start the engine, rotate the kick crank, push down lightly with foot until gears engage, and then kick with full strength

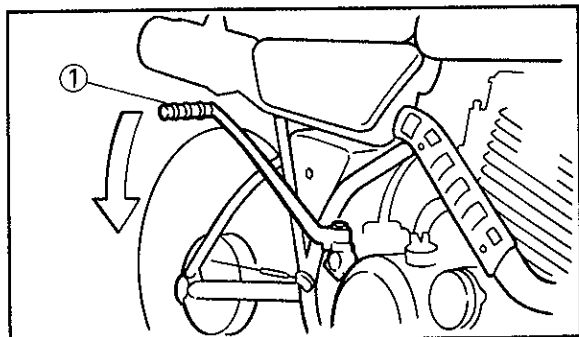

1 Kick starter

NOTE:

This model features an autodecomp. device, which frees the operator from the trouble otherwise required.

Sidestand

This model is equipped with an ignition circuit cut-off system. The motorcycle must not be ridden when the sidestand is down. The sidestand is located on the left side of the frame. (Refer to page 5-2 for an explanation of this system.)

⚠ WARNING:

This motorcycle must not be operated with the sidestand in the down position. If the stand is not properly retracted, it could contact the ground and distract the operator resulting in a possible loss of control. Yamaha has designed into this motorcycle a lockout system to assist the operator in fulfilling his responsibility of retracting the sidestand. Please check carefully the operating instructions listed below and if there is any indication of a malfunction, you must return the motor-

cycle to a Yamaha dealer immediately for repair.

Sidestand switch operation check

Check the operation of the sidestand switch against the information below.

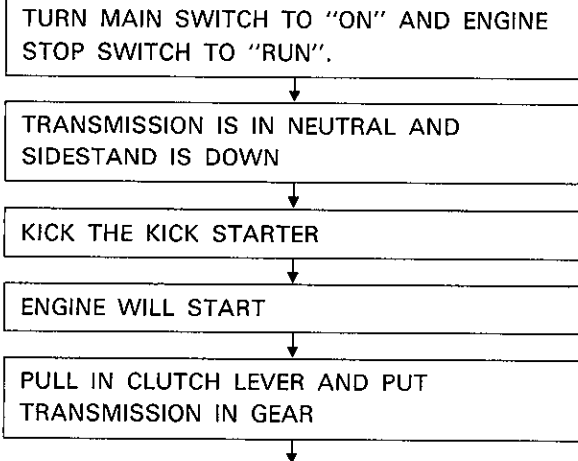

ENGINE WILL STALL

SIDESTAND SWITCH IS OK.

⚠ WARNING:

If improper operation is noted, consult a Yamaha dealer immediately.

PRE-OPERATION CHECKS

Before using this motorcycle please check the following points:

Item	Routine	Page
Brakes	Check operation/adjustment	4-2, 6-15 ~ 6-18
Clutch	Check operation/lever adjustment	4-2, 6-18 ~ 6-19
Throttle	Check for proper throttle cable operation	4-2, 6-12
Engine oil	Check oil level/top-off as required	4-2, 6-6 ~ 6-9
Drive chain	Check alignment/adjustment/lubrication	4-2, 6-19 ~ 6-22
Wheels and tires	Check pressure/runout/spoke tightness	4-3 ~ 4-5, 6-28 ~ 6-32
Fittings/fasteners	Check all-tighten as necessary	6-5
Lights/signals	Check operation	4-6
Battery	Check fluid level, top-up with distilled water if necessary	6-24 ~ 6-26
Fuel tank	Check fuel level/top-off as required	4-6

NOTE:

Pre-operation checks should be made each time the motorcycle is used. Such an inspection can be thoroughly accomplished in a very short time; and the added safety it assures is more than worth the time involved.

⚠WARNING:

If any item in the Pre-Operation Check is not working properly, have it inspected and repaired before operating the motorcycle.

Brakes

Check for correct play in the brake lever and pedal and make sure they are working properly. Check the brakes at low speed shortly after starting out. If the play is incorrect, make an adjustment. (See page 6-15)

Clutch

Check for correct play in the clutch lever and make sure the lever operates properly. If the play is incorrect, make an adjustment (See page 6-18)

Throttle grip

Turn the throttle grip to see if it operates properly and if the play is normal. Make certain the throttle springs closed when released.

Engine oil

Make sure the engine oil is at the specified level.

Add oil as necessary.

Recommended oil:

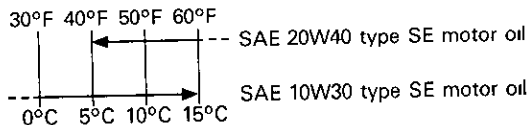

Oil quantity:

Total amount:

1.6 L (1.4 Imp qt, 1.7 US qt)

Periodic oil change:

1.3 L (1.14 Imp qt, 1.37 US qt)

NOTE:

Recommended engine oil classification; API Service "SE", "SF" type or equivalent (e.g. "SF-SE", "SF-SE-CC", "SF-SE-SD" etc.).

Drive chain

Check the chain tension and condition. Adjust if necessary. (See page 6-19)

Tires

To ensure maximum performance, long service, and safe operation, note the following:

1. Tire air pressure

Always check and adjust the tire pressure before operating the motorcycle.

⚠WARNING:

Tire inflation pressure should be checked and adjusted when the temperature of the tire equals the ambient air temperature. Tire inflation pressure must be adjusted according to total weight of cargo, rider, passenger, and accessories (fairing, saddlebags, etc. if approved for this model), and vehicle speed.

Basic weight With oil and full fuel tank	122 kg (269 lb)	
Maximum load*	160 kg (353 lb)	
Cold tire pressure	Front	Rear
Up to 90 kg (198 lb) load*	130 kPa (1.3 kg/cm ² , 18 psi)	150 kPa (1.5 kg/cm ² , 21 psi)
90 kg (198 lb) ~ Maximum load*	150 kPa (1.5 kg/cm ² , 21 psi)	180 kPa (1.8 kg/cm ² , 26 psi)
High speed riding	150 kPa (1.5 kg/cm ² , 21 psi)	180 kPa (1.8 kg/cm ² , 26 psi)

*Load is the total weight of cargo, rider, passenger, and accessories

⚠WARNING:

Proper loading of your motorcycle is important for the handling, braking, and other performance and safety characteristics of your motorcycle. Do not carry loosely packed items that can shift. Securely pack your heaviest items close to the center of the motorcycle, and distrib-

ute the weight evenly from side to side. Check the condition and pressure of your tires. **NEVER OVERLOAD YOUR MOTORCYCLE.** Make sure the total weight of the cargo, rider, passenger, and accessories (fairing, saddlebags, etc. if approved for this model) does not exceed the maximum load of the motorcycle. Operation of an overloaded motorcycle could cause tire damage, an accident, or even injury.

2. Tire inspection

Always check the tires before operating the motorcycle. If a tire tread shows crosswise lines (minimum tread depth), if the tire has a nail or glass fragments in it, or if the side wall is cracked, contact a Yamaha dealer immediately and have him replace the tire.

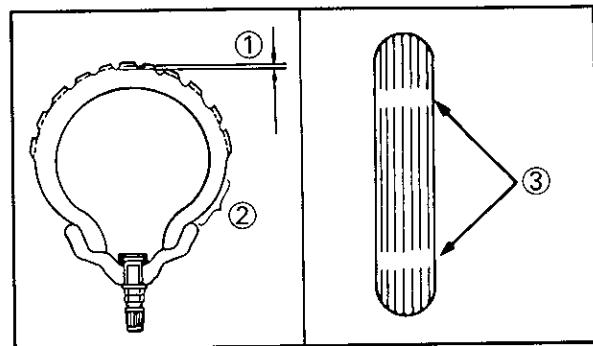

1 Tread depth 2 Side wall 3 Wear indicator

FRONT

Manufacture	Size	Type
Bridgestone	3 00-21 4PR	TRAIL WING-11

REAR

Manufacture	Size	Type
Bridgestone	4 60-17 4PR	TRAIL WING-10

Minimum tire tread depth (front and rear)	1 0 mm (0 04 in)
---	------------------

⚠ WARNING:

- 1. It is dangerous to ride with a worn-out tire. When a tire tread begins to show lines, have a Yamaha dealer replace the tire immediately. Brakes, tires, and related wheel parts replacement should be left to a Yamaha Service Technician.**
 - 2. Patching a punctured tube is not recommended. If it is absolutely necessary to do so, use great care and replace the tube as soon as possible with a good quality replacement.**
-

Wheels

To ensure maximum performance, long service, and safe operation, note the following:

- 1. Always inspect the wheels before a ride. Check for cracks, bends or warpage of the wheel; be sure the spokes are tight and undamaged. If any abnormal condition exists in a wheel, consult a Yamaha dealer. Do not attempt even small repairs to the wheel. If a wheel is deformed or cracked, it must be replaced.**
- 2. Tires and wheels should be balanced whenever either one is changed or replaced. Failure to have a wheel balanced can result in poor performance, adverse handling characteristics, and shortened tire life.**
- 3. After installing a tire, ride conservatively to allow the tire to seat itself on the rim properly. Failure to allow proper seating may cause tire failure, resulting in damage to the motorcycle and injury to the rider.**

Lights and signals

Check the headlight, flasher lights, taillight, brake light, meter lights and all the indicator lights to make sure they are in working condition.

Fuel

Make sure there is sufficient fuel in the tank.

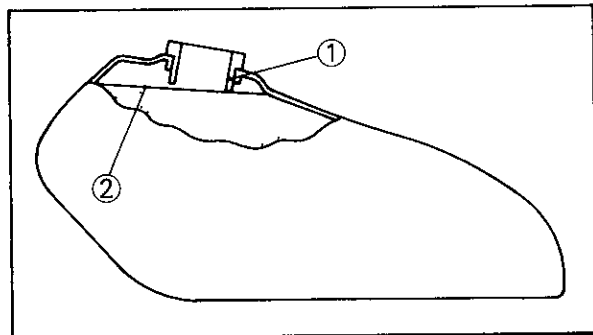

1 Filler tube

2 Fuel level

⚠ WARNING:

Do not overfill the fuel tank. Avoid spilling fuel on the hot engine. Do not fill the fuel tank above the bottom of the filler tube as shown in the illustration or it may overflow when the fuel heats up later and expands.

Recommended fuel: Unleaded fuel only

Fuel tank capacity:

Total:

8.0 L (2.1 Imp gal, 1.8 US gal)

Reserve:

1.7 L (0.37 Imp gal, 0.45 US gal)

OPERATION AND IMPORTANT RIDING POINTS

⚠ WARNING: _____

Before riding this motorcycle, become thoroughly familiar with all operating controls and their function.

Consult your Yamaha dealer regarding any control or function you do not thoroughly understand.

⚠ WARNING: _____

1. Never start your engine or let it run for any length of time in a closed area. The exhaust fumes are poisonous and can cause loss of consciousness and death within a short time. Always operate your motorcycle in an area with adequate ventilation.

2. Before starting out, always be sure the sidestand is up. Failure to retract the sidestand completely can result in a serious accident when you try to turn a corner.
-

Starting a cold engine

NOTE: _____

This motorcycle is equipped with an ignition circuit cut-off switch.

1. The engine can be started only under the following conditions:
 - a. The transmission is in neutral.
 - b. The sidestand is up, the transmission is in gear, and the clutch is disengaged.
 2. The motorcycle must not be ridden when the sidestand is down.
-

⚠ WARNING:

Before going through the following steps, check the function of the sidestand switch. (Refer to page 3-8)

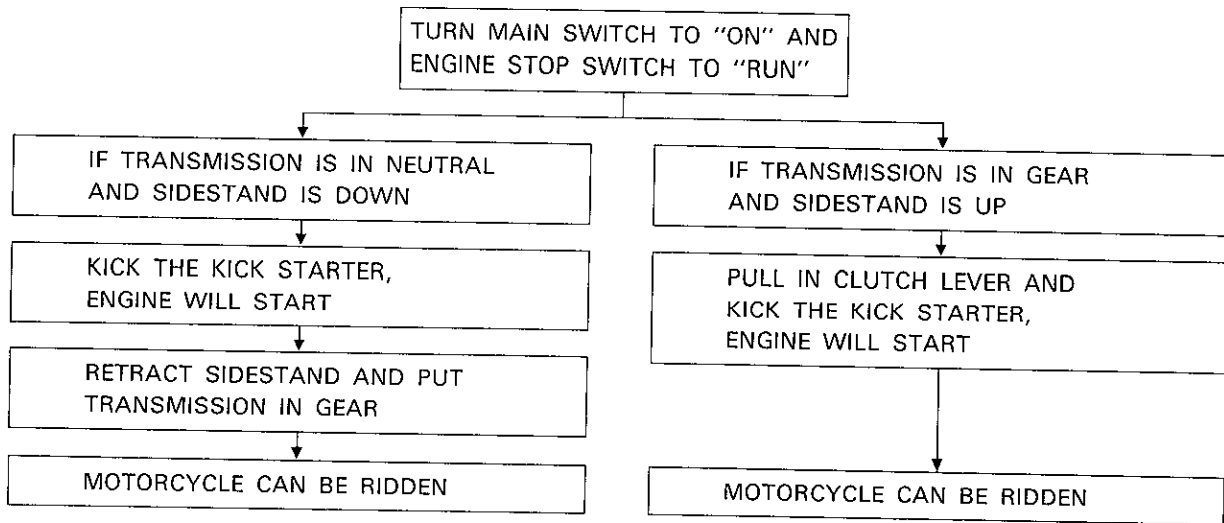

1. Turn the fuel cock to "ON".
2. Turn the ignition key to the "ON" position and the engine stop switch to "RUN".
3. Shift transmission into neutral.

NOTE: _____

When the transmission is in neutral, the neutral indicator light (green) should be on. If the light does not come on ask your Yamaha dealer to inspect.

4. Open the carburetor starter lever (CHOKE) by pushing down on the lever and completely close the throttle grip.
5. Kick the kick crank with full strength to start the engine.
6. After the engine starts, warm up for one or two minutes. Make sure the starter is returned to the original position before riding.

Starting a warm engine

1. Do not use starter lever (CHOKE) but start the engine with the throttle grip slightly opened according steps 5 to 6 in "Starting a cold engine".

NOTE: _____

In case engine does not start after several kicking strokes in above procedure, kick the pedal again, this time with throttle grip opened approx. 1/4 to 1/2.

Warming up

To get maximum engine life, always "warm-up" the engine before starting off. Never accelerate hard with a cold engine! To see whether or not the engine is warm, see if it responds to throttle normally with the starter lever (CHOKE) turned off.

Engine break-in

NOTE:

1. After fueling and pre-operational checks have been made, refer to "OPERATION AND IMPORTANT RIDING POINTS" and start the engine.
 2. Allow the engine to warm-up. Check engine idle speed. Check operating controls and engine stop switch operation.
-

- 1 0 ~ 250 km (0 ~ 150 mi):
Avoid operation above half-throttle.
- 2 250 ~ 500 km (150 ~ 300 mi):
Avoid operation above 3/4 throttle.
3. 500 km (300 mi) and beyond:
Full-throttle operation is allowed, but unnecessary full-throttle operation should be avoided. After 500 km (300 mi) operation, be sure to replace the engine oil and oil filter element, and clean the oil strainers.

CAUTION:

If any engine trouble should occur during the break-in period, consult your Yamaha dealer immediately.

Parking

When parking, stop the engine and remove the ignition key.

WARNING:

The muffler and exhaust pipe are hot. Park the motorcycle in a place where pedestrians or children are not likely to touch the motorcycle.

Do not park the motorcycle on a slope or soft ground; the motorcycle can easily overturn.

PERIODIC MAINTENANCE AND MINOR REPAIR

Periodic inspection adjustment and lubrication will keep your motorcycle in the safest and most efficient condition possible. Safety is an obligation of the motorcycle owner.

The most important points of motorcycle inspection, adjustment and lubrication are explained in the following pages.

⚠ WARNING:

If the owner is not familiar with motorcycle service, this work should be done by a Yamaha dealer.

Tool kit

The servicing information included in this manual is intended to provide you, the owner, with the necessary information for completing your own preventive maintenance and minor repairs. The tools provided in the owner's tool kit are sufficient for this purpose, except that a torque wrench is also necessary to properly tighten nuts and bolts.

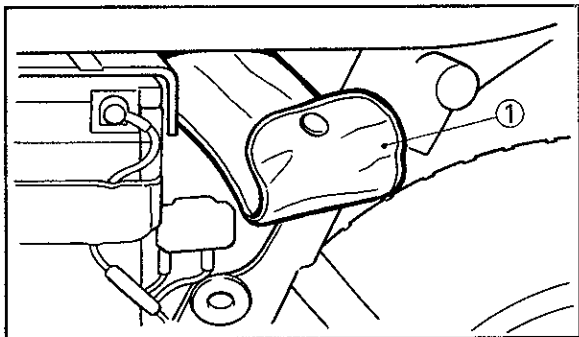

1 Tool kit

NOTE: _____

If you do not have a torque wrench available during a service operation requiring one, take your motorcycle to a Yamaha dealer to check the torque settings and adjust them as necessary.

PERIODIC MAINTENANCE/LUBRICATION

Unit km (miles)

ITEM	REMARKS	BREAK-IN 1,000 (600)	EVERY	
			6,000 (4,000) or 6 months	12,000 (8,000) or 12 months
Valve (s)*	Check valve clearance Adjust if necessary	○	○	○
Cam chain	Check chain tension Adjust if necessary	○	○	○
Spark plug	Check condition Clean or replace if necessary	○	○	○
Air filter	Clean. Replace if necessary.		○	○
Carburetor*	Check idle speed (/synchronization)/starter operation Adjust if necessary	○	○	○
Fuel line*	Check fuel hose for cracks or damage Replace if necessary		○	○
Engine oil	Replace (Warm engine before draining)	○	○	○
Engine oil filter*	Clean	○		○
Brake (for drum brake)	Check operation Adjust if necessary		○	○
Clutch	Check operation Adjust if necessary		○	○
Rear arm pivot* (nipple)	Check rear arm assembly for looseness Correct if necessary Moderately repack **(***)	○	○	○
Wheels* (for spoke wheel)	Check balance/damage/runout/spoke tightness Repair if necessary		○	○
Wheel bearings*	Check bearings assembly for looseness/damage Replace if damaged		○	○

ITEM	REMARKS	BREAK-IN 1,000 (600)	EVERY	
			6,000 (4,000) or 6 months	12,000 (8,000) or 12 months
Steering bearing*	Check bearings assembly for looseness Correct if necessary Moderately repack every 24,000 (16,000) or 24 months **	○		○
Front forks*	Check operation/oil leakage Repair if necessary		○	○
Rear shock absorber*	Check operation/oil leakage Repair if necessary		○	○
Drive chain	Check chain slack/alignment Adjust if necessary Clean and lube	EVERY 500 (300)		
Fittings/Fasteners*	Check all chassis fittings and fasteners Correct if necessary	○	○	○
Sidestand*	Check operation Repair if necessary	○	○	○
Battery*	Check specific gravity Check breather pipe for proper operation Correct if necessary		○	○

* It is recommended that these items be serviced by a Yamaha dealer

** Medium weight wheel bearing grease

*** Lithium soap base grease

Torque specifications

Use a torque wrench to tighten these items. It is recommended that these items be checked occasionally, especially before a long tour. Always check the tightness of these items whenever they are loosened for any reason.

Item	Torque		
	Nm	m kg	ft lb
Spark plug	20	2.0	14.5
Cam chain tensioner cover	5	0.5	3.6
Engine drain plug	32	3.2	23.0
Kick starter	20	2.0	14.5
Change pedal	8	0.8	5.8
Front engine mount bolts	33	3.3	24.0
Rear engine mount bolts	33	3.3	24.0
Steering pinch bolts (8 mm stud)	20	2.0	14.5
Shock absorber (top)	25	2.5	18.0
Front wheel axle	105	10.5	76.0
Rear wheel axle	105	10.5	76.0

A (Nut)	B (Bolt)	Torque specification		
		Nm	m kg	ft lb
10 mm	6 mm	6	0.6	4.3
12 mm	8 mm	15	1.5	11
14 mm	10 mm	30	3.0	22
17 mm	12 mm	55	5.5	40
19 mm	14 mm	85	8.5	61
22 mm	16 mm	130	13.0	94

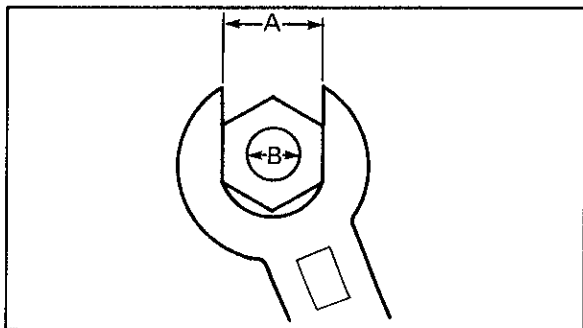

Engine oil

- 1 Oil level measurement
 - a Place the motorcycle on a level place and hold it in an upright position. Warm up the engine for several minutes.

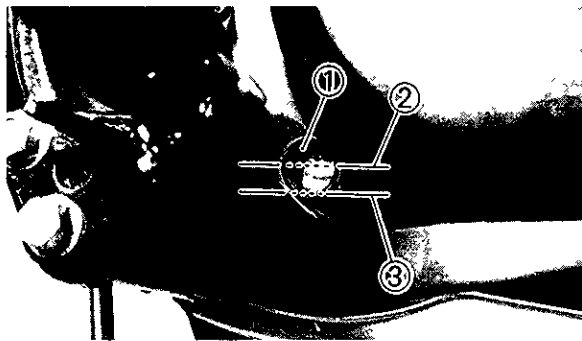

- 1 Level window
2 Maximum mark
3 Minimum mark

NOTE: _____

Be sure the motorcycle is positioned straight up when checking the oil level; a slight tilt toward the side can produce false readings.

- b. With the engine stopped, check the oil level through the level window located at the lower part of the right side crankcase cover.

NOTE: _____

Wait a few minutes until the oil level settles before checking.

- c The oil level should be between maximum and minimum marks. If the level is lower, add sufficient oil to raise it to the proper level.
2. Engine oil replacement
 - a Start the engine and stop after a few minutes of warm-up.
 - b Place an oil receiver under the engine.
 - c. Remove the oil filler cap, drain plug, and air bleeder screw attached to the oil filter cover.

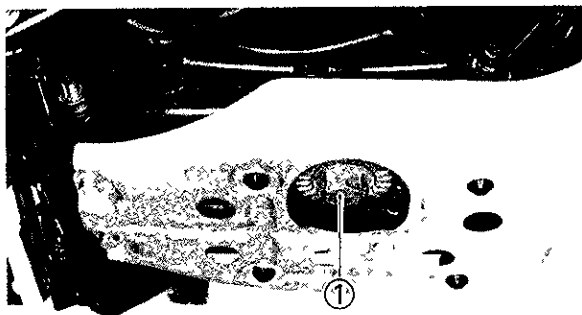

1 Drain plug

NOTE: _____

The oil filter cover is secured by three screws. The lower one should be removed so that the filter cavity will drain.

CAUTION: _____

When removing the drain plug, the compression spring, oil strainer, O-ring, and oil pipe could easily fall off. Take care not to lose these parts.

- d. Check each gasket. If damaged, replace it.
- e. Install the drain plug, the bleed screw, and the filter cover screw.

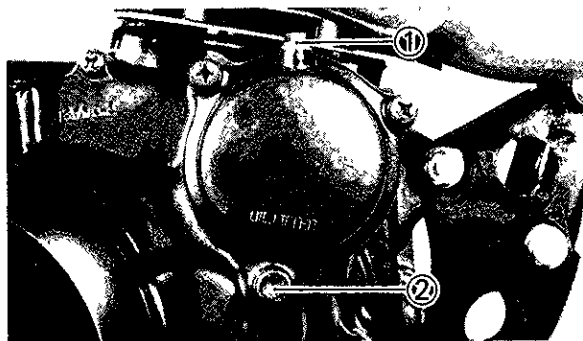

1 Air bleeder screw

2 Filter cover screw

CAUTION: _____

Before reinstalling the drain plug, do not forget to fit the O-ring, compression spring, oil strainer, and oil pipe.

Drain plug torque:

32 Nm (3.2 m·kg, 23.0 ft·lb)

- f. Add 1.3 L (1.4 Imp qt, 1.37 US qt) of engine oil. Install the oil filler cap and tighten.
- g. Start the engine and allow a few minutes of warm-up.
While warming up, check for oil leakage. If oil leaks, stop the engine immediately, and check for the cause.
- h. Stop the engine and check the oil level.

CAUTION

After replacing the engine oil, be sure to check the oil pressure as described below.

1. Remove the air bleed screw from oil filter cover, and remove the check bolt in the cylinder head.

2. Start the engine and keep it idling until oil flows out of the bleed hole, and the check bolt (see the following photo).

If no oil comes out after a lapse of one minute, turn off the engine immediately so it will not seize. In such a case go to the nearest Yamaha dealer for repairs.

3. After checking, tighten the air bleed screw securely.

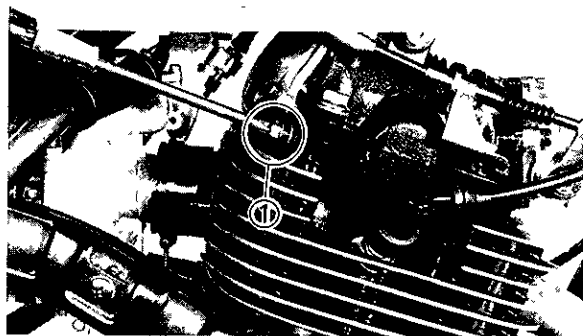

1 Check bolt

3. Oil filter replacement

Ask your Yamaha dealer to replace the engine oil filter element.

Air filter

The air filter protects the engine from dirt which can enter with the intake air and cause rapid engine wear. This dirt is filtered from the air by the air filter element. This model uses a cartridge type air filter element which consists of foam rubber moistened with oil. When this filter element becomes dirty it should be cleaned.

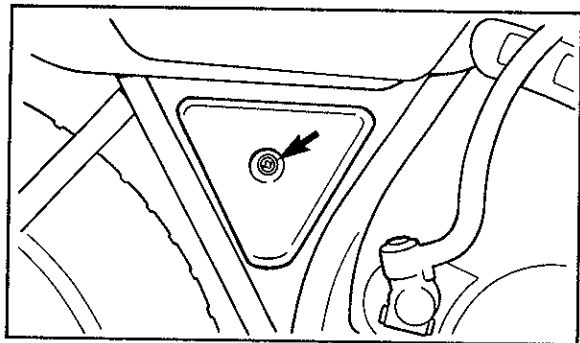

1. Remove the air filter element from its case, remove element from guide and clean with solvent. After cleaning, remove the remaining solvent by squeezing the element.

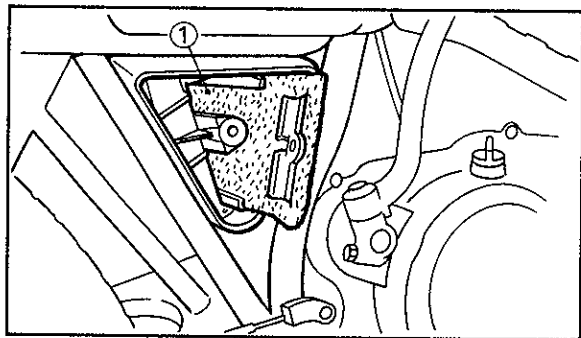

1 Air filter element

⚠ CAUTION:

Before taking out the element, remember the direction in which it was installed. Use this direction in reinstalling the cleaned element; otherwise, it will cause the carburetor to clog.

2. Then apply 2-stroke engine oil to the entire surface and squeeze out the excess oil. Element should be wet but not dripping.
3. When installing the air filter element in its case, be sure its sealing surface matches perfectly the sealing surface of the case so there is not air leakage.
4. The air filter element should be cleaned at the specified intervals. It should be cleaned more often if the motorcycle is operated in dusty or wet areas.

⚠ CAUTION:

The engine should never be run without the air cleaner element installed; excessive piston and/or cylinder wear may result.

Carburetor adjustment

The carburetor is a vital part of the engine and requires very sophisticated adjustment. Most adjusting should be left to a Yamaha dealer who has the professional knowledge and experience to do so. However, the following point may be serviced by the owner as part of his usual maintenance routine.

⚠ CAUTION:

The carburetor was set at the Yamaha factory after many tests. If the settings are disturbed without having technical knowledge, poor engine performance and damage may result.

Idling speed adjustment

- 1 Start the engine and warm it up for a few minutes (normally 1 or 2 minutes) at approximately 1,000 to 2,000 r/min, occasionally raising to 4,000 ~ 5,000 r/min for a few seconds. When the engine responds quickly, the warm-up is complete.

NOTE:

Use a tachometer for proper idling speed setting.

2. Set the engine idle speed to specified revolutions by turning the throttle stop screw in to increase the engine speed and back off the idle speed adjust screw to decrease the engine speed.

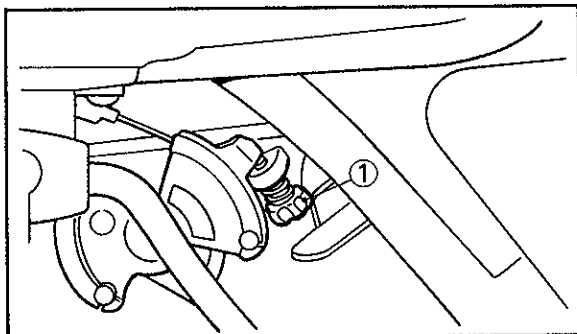

1 Throttle stop screw

Standard idling speed: 1,200 r/min

NOTE:

If the specific idling speed can not be obtained after performing the above adjustment, consult your Yamaha dealer.

Throttle cable adjustment

NOTE:

Idle speed should be set before making this adjustment.

The throttle grip should have a play of 2 ~ 5 mm (0.08 ~ 0.2 in) in the turning direction at the grip flange. If the play is not in this range, take the following steps for adjustment

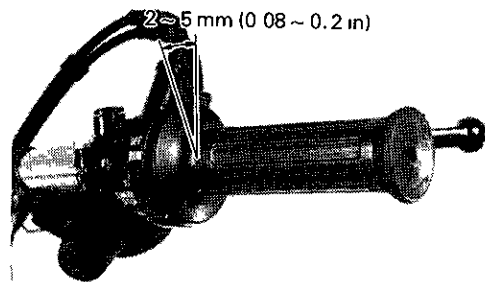

- Loosen the lock nuts on the carburetor side of throttle cable 1, and turn the adjuster in and out so the play is correct. After the adjustment, be sure to tighten the lock nut.
- If the play is still incorrect after the adjuster is loosened 5 mm (0.20 in), make an adjustment with the adjuster on the throttle cable 2

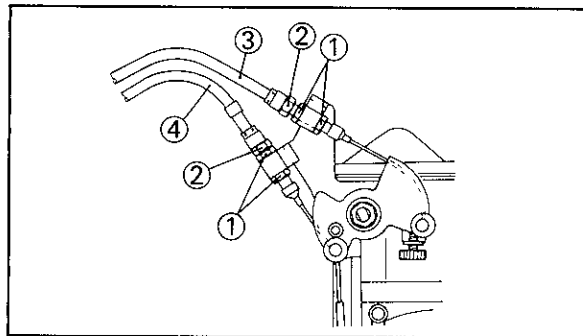

- | | |
|--------------------|--------------------|
| 1 Lock nut | 2 Adjuster |
| 3 Throttle cable 1 | 4 Throttle cable 2 |

Cam chain adjustment

The cam chain becomes longer with use, resulting in improper valve timing and engine noise. To prevent this, the cam chain tensioner must be adjusted regularly. This adjustment, however, should be left to a professional Yamaha service technician.

Valve clearance adjustment

The valve clearance becomes larger with use, resulting in improper fuel/air supply and engine noise.

To prevent this, the valve clearance must be adjusted regularly. This adjustment, however, should be left to a professional Yamaha service technician.

Decompression cable adjustment

The decompression cable becomes longer with use, resulting in improper decompression function. To prevent this, the decompression cable must be adjusted regularly. This adjustment, however, should be left to a professional Yamaha service technician.

Spark plug inspection

The spark plug is an important engine component and is easy to inspect. The condition of the spark plug can indicate something of the condition of the engine.

The ideal color on the white porcelain insulator around the center electrode is a medium to light tan color for a motorcycle that is being ridden normally. Do not attempt to diagnose any problems yourself. Instead, take the motorcycle to a Yamaha dealer. You should periodically remove and inspect the spark plug because heat and deposits will cause the spark plug to slowly break down and erode. If electrode erosion becomes excessive, or if carbon and other deposits are excessive, you should replace the spark plug with a proper type plug.

Standard spark plug:
BP7ES (NGK)

Before installing the spark plug, measure the electrode gap with a wire thickness gauge; adjust the gap to specification as necessary.

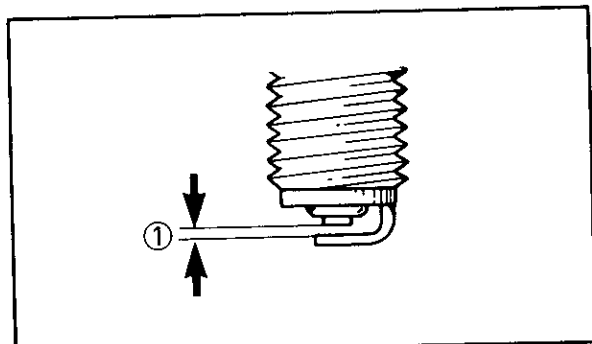

1 Spark plug gap

Spark plug gap:
0.7 ~ 0.8 mm (0.028 ~ 0.031 in)

When installing the plug, always clean the gasket surface and use a new gasket. Wipe off any grime from the threads, and torque the spark plug properly.

Spark plug torque:
20 Nm (2.0 m•kg, 14 ft•lb)

NOTE: _____

If a torque wrench is not available when you are installing a spark plug, a good estimate of the correct torque is 1/4 to 1/2 turns past finger tight. Have the spark plug torqued to the correct value as soon as possible with a torque wrench.

Front brake adjustment

The front brake should be adjusted to suit rider preference within a 5 ~ 8 mm (0.2 ~ 0.3 in) free play at the lever pivot side.

Adjustment is accomplished at one of two places; either the handlebar lever holder or the front brake hub.

1. Loosen the lock nut.
2. Turn the cable length adjuster in or out until adjustment is suitable.
3. Tighten the lock nut.
4. If proper adjustment can not be obtained at the handlebar lever holder, have a Yamaha dealer make a brake hub adjustment.

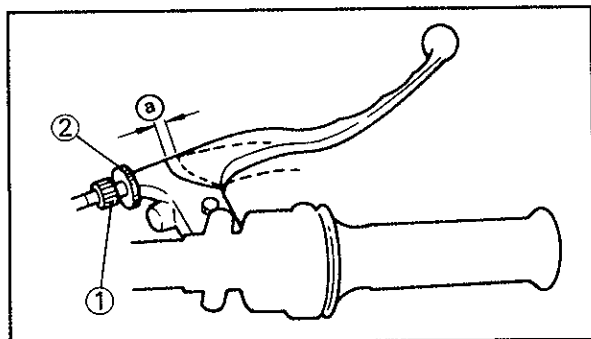

1 Adjuster
2 Lock nut

a 5 ~ 8 mm
(0.2 ~ 0.3 in)

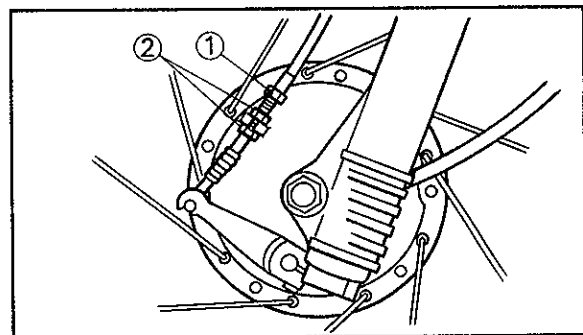

1 Adjuster

2 Lock nut

Rear brake adjustment

The rear brake should be adjusted to suit rider preference within a 20 ~ 30 mm (0.8 ~ 1.2 in) free play at the brake pedal end.

1. Loosen the adjuster lock nut (for pedal height).
2. By turning the adjuster bolt clockwise or counterclockwise, adjust the brake pedal position so that its top end is approx 15 mm (0.6 in) below the footrest top end

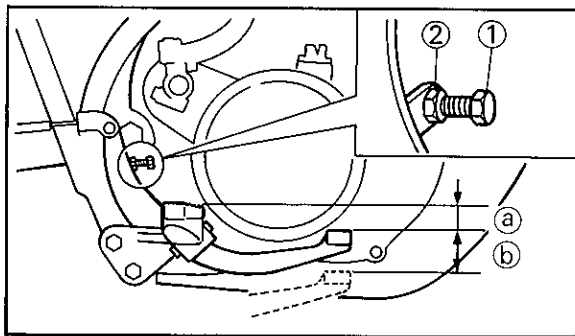

- | | |
|---------------------------------------|-------------------------|
| 1 Adjuster bolt
(For pedal height) | a 15 mm (0.6 in) |
| 2 Lock nut | b 20~30 mm (0.8~1.2 in) |

- 3 Secure the adjuster lock nut
4. To adjust, turn the adjuster on the brake rod clockwise to reduce play; turn the adjuster counterclockwise to increase play

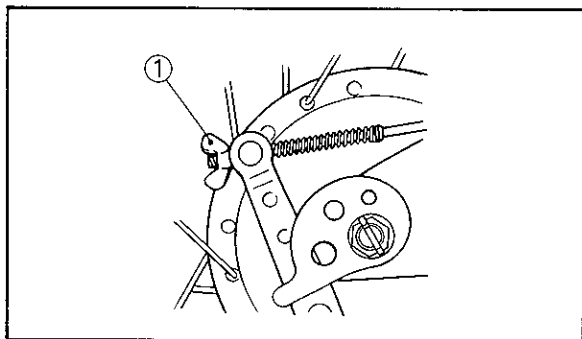

1 Adjuster

⚠ WARNING:

1. The rear brake pedal adjustment must be checked anytime chain is adjusted or rear wheel is removed and then reinstalled.
2. Check whether or not the brake light operates correctly after adjusting.

Checking the brake shoes (Front brake)

A wear indicator is attached to the front brake to facilitate brake shoes check. This indicator permits a visual check without disassembling the brake.

To check, look at the wear indicator while pulling the brake lever. If the indicator reaches to the wear limit line, ask a Yamaha dealer to replace shoes.

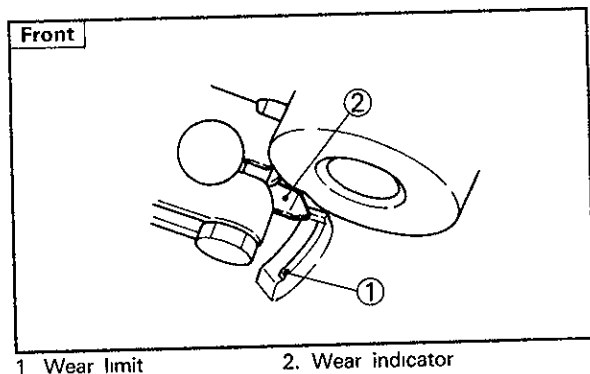

Brake lining inspection (Rear brake)

The specified thickness of the brake lining is 4 mm (0.16 in). The lining should be replaced when it wears to less than 2 mm (0.08 in).

To inspect, remove the plug from the inspection hole on the brake shoe plate and check the thickness of the lining. If worn out, ask your Yamaha dealer to install a new set. Be sure to replace the plug carefully so water cannot enter the shoe plate.

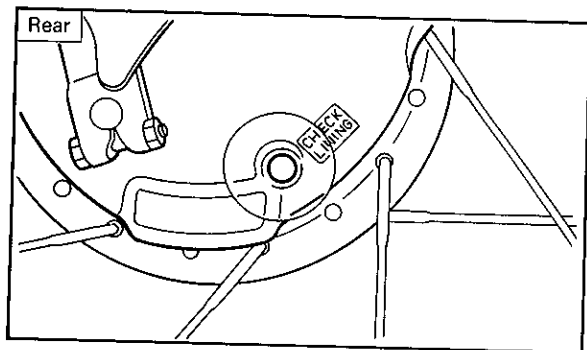

⚠ WARNING:

Be sure to replace the inspection hole plug securely. If water enters the brake shoe area, it can cause a temporary loss of braking capability which may cause loss of control and injury.

Brake light switch adjustment

The brake light switch is operated by movement of the brake pedal. To adjust, hold the main body of the switch with the hand so it does not rotate and turn the adjusting nut.

Proper adjustment is achieved when the brake light comes on slightly before the brake begins to take effect.

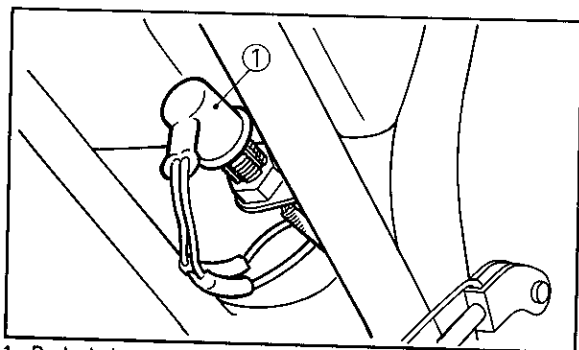

1 Brake light switch

Clutch adjustment

This model has a clutch cable length adjuster and a clutch mechanism adjuster. Adjustment at the clutch lever is normally recommended. Loosen the lock nut and turn the adjuster to adjust the clutch lever. The clutch should be adjusted to suit rider preference within a 2 ~ 3 mm (0.08 ~ 0.12 in) free play at the lever pivot side.

After adjusting, be sure the lock nut is tightened firmly. When it is impossible to make an adjustment at the case cover, ask your Yamaha dealer to adjust the internal mechanism.

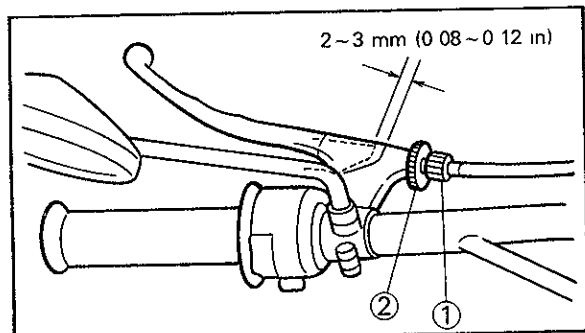

1 Adjuster

2 Lock nut

Drive chain slack check

NOTE:

1. Before checking and/or adjusting, rotate the rear wheel through several revolutions. Check the chain slack at several points to find the tightest point. Check and/or adjust the chain slack with the rear wheel in this "tightest" position.
2. Slack check should be made with the tensioner in the relaxed position (not touching the chain).

To check the chain slack, the motorcycle must stand vertically with its both wheels on the ground and without passenger on it. Check the slack at the position shown in the illustration. The normal vertical deflection is approximately 50~60 mm (2.0~2.4 in). If the deflection exceeds 60 mm (2.4 in) adjust the chain slack.

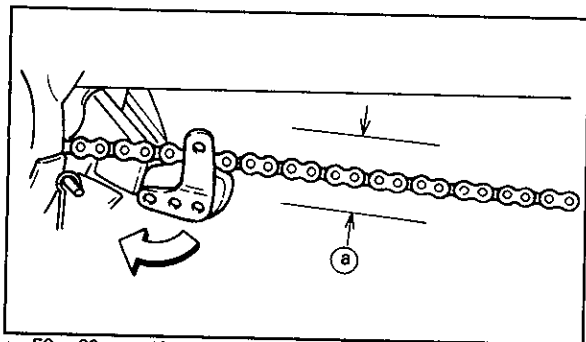

a. 50 ~ 60 mm (2.0 ~ 2.4 in)

Drive chain slack adjustment

1. Loosen the rear brake adjuster.
2. Remove the cotter pin of the rear wheel axle nut.
3. Loosen the rear wheel axle nut.
4. Turn the chain puller both left and right, until axle is situated in same puller slot position on each side
5. Tighten the rear axle nut.

Axle nut torque:

105 Nm (10,5 m · kg, 76,0 ft · lb)

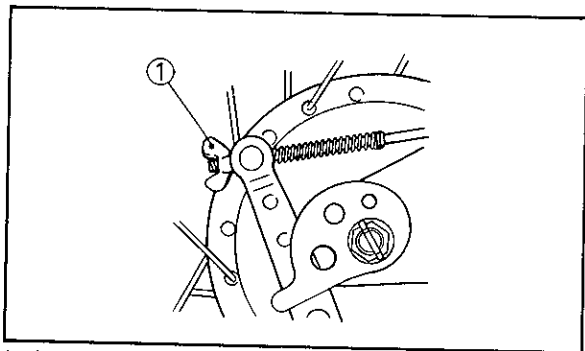

1 Adjuster

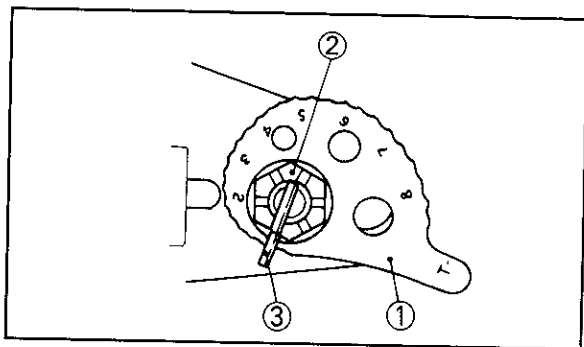

1 Chain puller

2 Axle nut

3 Cotter pin

6. Insert the cotter pin into the rear wheel axle nut and bend the end of the cotter pin as shown in the illustration (if the nut notch, and the cotter pin hole do not match, tighten the nut slightly to match)

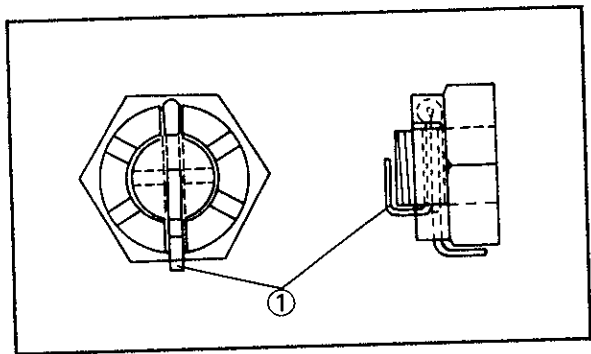

1. Cotter pin

⚠WARNING:

Always use a new cotter pin on the axle nut.

7. In the final step, adjust the play in the brake pedal.

⚠CAUTION:

Too small chain slack will overload the engine and other vital parts; keep the slack within the specified limits.

Drive chain lubrication

The chain consists of many parts which work against each other. If the chain is not maintained properly, it will wear out rapidly, therefore, form the habit of periodically servicing the chain. This service is especially necessary when riding in dusty conditions.

1. First, remove dirt and mud from the chain with a brush or cloth and then spray the lubricant between both rows of side plates and on all center rollers.

2. To clean the entire chain, first remove the chain from the motorcycle, dip it in solvent and clean out as much dirt as possible. Then take the chain out of the solvent and dry it immediately, lubricate the chain to prevent the formation of rust.

Cable inspection and lubrication

⚠WARNING:

Damage to the outer housing of the various cables may cause corrosion and often free movement will be obstructed. An unsafe condition may result so replace such cables as soon as possible.

Lubricate the inner cable and cable end. If they do not operate smoothly, ask your Yamaha dealer to replace them.

Recommended lubricant:
SAE 10W30 motor oil

Lubrication of levers, pedals, etc.

1. Lubricate the pivoting parts of the brake and clutch levers with SAE 10W30 motor oil
2. Lubricate the shaft of the brake pedal with SAE 10W30 motor oil.

Front fork inspection

⚠WARNING:

Securely support the motorcycle so there is no danger of it falling over.

1. Visual check
Check any scratch/damage on the inner tube and excessive oil leakage with the front fork.

NOTE:

If you find any leaks or damage, ask a Yamaha dealer to inspect.

2. Operation check

Place the motorcycle on a level place.

- a. Hold the motorcycle on an upright position with a rider's hands on the handlebar and apply the front brake.
- b. Pump the front fork up and down for several times.

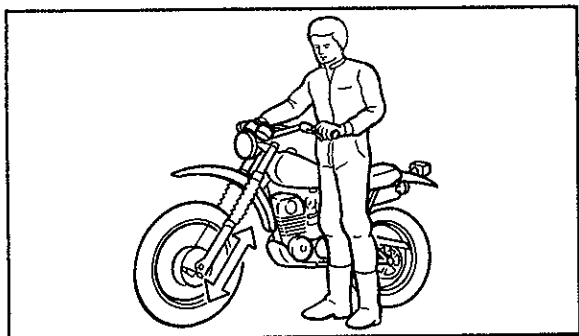

NOTE:

If the front fork movement is not smooth, consult a Yamaha dealer.

Steering inspection

Periodically inspect the condition of the steering. Worn out or loose steering bearings may be dangerous.

Place a block under the engine to raise the front wheel of the motorcycle off the ground, then hold the lower end of the front fork and try to move forward and backward. If any free play can be felt, ask a Yamaha dealer to inspect and adjust the steering assembly.

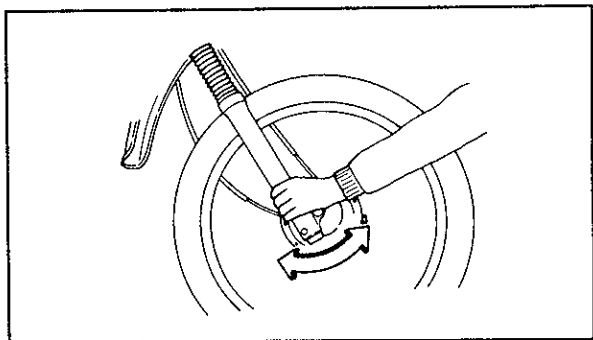

⚠WARNING:

Securely support the motorcycle so there is no danger of it falling over.

Wheel bearings

If the wheel bearings in the front or rear wheel allow play in the wheel hub or if the wheel does not turn smoothly, have a Yamaha dealer inspect the wheel bearings. The wheel bearings should be inspected according to the Maintenance Schedule.

Battery

Check the level of the battery fluid and see if the terminals are tight. Add distilled water if the fluid level is low

⚠CAUTION:

When inspecting the battery, be sure the breather pipe is routed correctly. If the breather pipe touches the frame or exits in such a way as to cause battery electrolyte or gas to exit onto the frame, structural and cosmetic damage to the motorcycle can occur.

⚠WARNING:

Battery fluid is poisonous and dangerous, causing severe burns, etc. Contains sulfuric acid. Avoid contact with skin, eyes or clothing. Antidote: **EXTERNAL**—Flush with water. **INTERNAL**—Drink large quantities of water or milk. Follow with milk of magnesia, beaten egg or vegetable oil. Call physician immediately.

Eyes: Flush with water for 15 minutes and get prompt medical attention. Batteries produce explosive gases. Keep sparks, flame, cigarettes, etc., away. Ventilate when charging or using in enclosed space. Always shield eyes when working near batteries. **KEEP OUT OF REACH OF CHILDREN.**

Replenishing the battery fluid

A poorly maintained battery will deteriorate quickly. The battery fluid should be checked at least once a month.

1. The level should be between the upper and lower level marks. Use only distilled water if refilling is necessary.

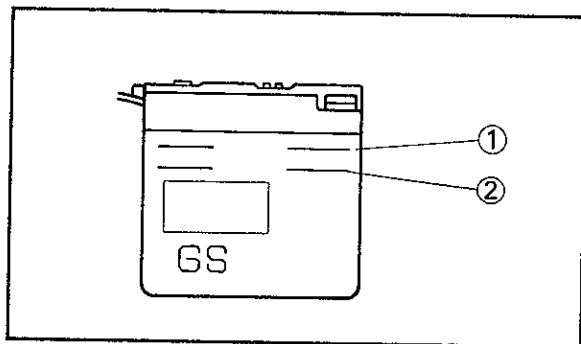

1 Upper level

2 Lower level

CAUTION:

Normal tap water contains minerals which are harmful to a battery; therefore, refill only with distilled water.

WARNING:

Battery fluid on the chain can cause premature failure and a possible accident.

2. When the motorcycle is not to be used for a month or longer, remove the battery and store it in a cool, dark place. Completely recharge the battery before reusing
3. If the battery is to be stored for a longer period than the above, check the specific gravity of the fluid at least once a month and recharge the battery when it is too low.
4. Always make sure the connections are correct when putting the battery back in the motorcycle. Make sure the breather pipe is properly connected and is not damaged or obstructed.

Circuit breaker

This model features a circuit breaker fitted behind the battery. If any problem should occur to an electric component and cause a short circuit, this breaker works to shut off the current.

If the current is thus shut off by the breaker, perform the following procedure:

1. Turn off the ignition switch and the switch in the circuit in question
2. Push in the breaker knob.

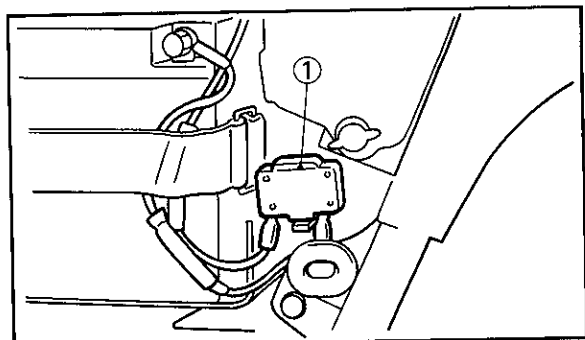

1 Circuit breaker

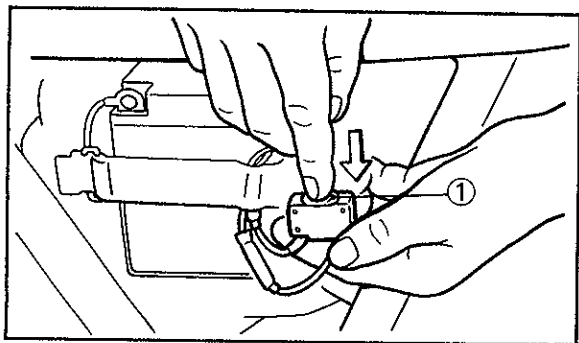

1 Breaker knob

CAUTION

Wait 30 seconds before resetting the circuit breaker.

3. Turn on the switches and see if the electrical device operates. If the circuit breaker interrupts the circuit again, consult a Yamaha dealer.

Replacing the headlight and tail/brake light bulb

If the light burns out, ask your Yamaha dealer for bulb replacement and adjustment.

Rear shock (Monocross suspension "De Carbon" system)

WARNING:

This shock absorber contains highly compressed nitrogen gas.

Read and understand the following information before handling the shock absorber. The manufacturer cannot be held responsible for property damage or personal injury that may result from improper handling.

1. Do not tamper or attempt to open the cylinder assembly.
2. Do not subject shock absorber to an open flame or other high heat. This may cause the unit to explode due

to excessive gas pressure.

3. Do not deform or damage the cylinder in any way. Cylinder damage will result in poor damping performance.
 4. To dispose of a damaged or worn out shock absorber, take the unit to your Yamaha dealer for this disposal procedure.
-

Front wheel removal

1. Elevate the front wheel by placing a suitable stand under the engine.
2. Remove brake cable; loosen all cable adjusters and remove cable from handlebar lever holder. Then remove cable from cam lever at front brake shoe plate.
3. Remove speedometer cable from front brake shoe plate: first remove clip and then pull cable out.

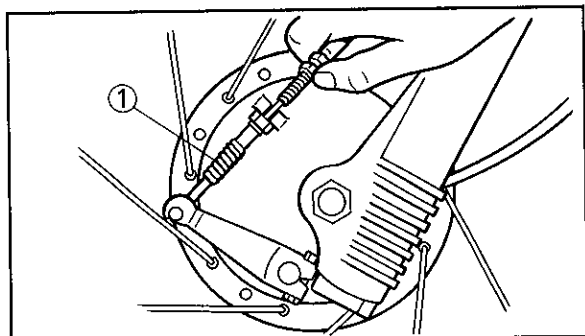

1 Brake cable

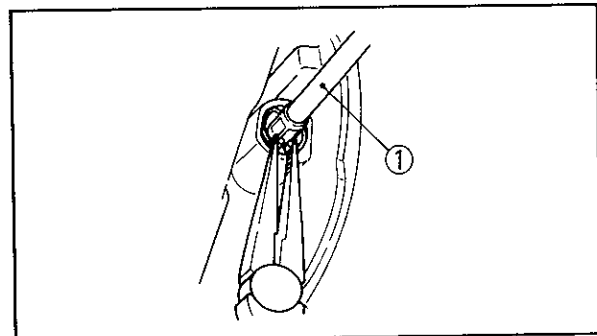

1 Speedometer cable

4. Remove cotter pin from front wheel axle and remove axle nut.

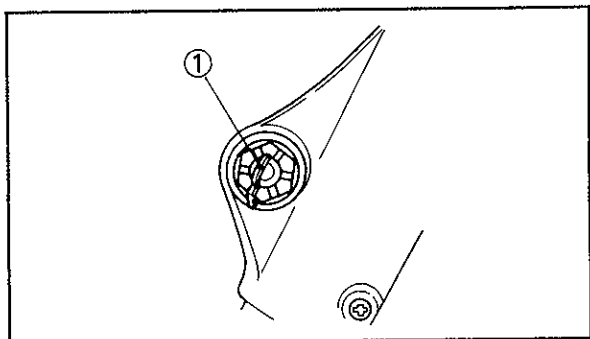

1 Cotter pin

5. Turn and pull out the front wheel axle; the wheel assembly can now be removed.

Front wheel installation

When installing front wheel, reverse the removal procedure taking the following steps:

1. Check for proper engagement of the boss on the outer fork tube with the locating slot on the brake shoe plate.

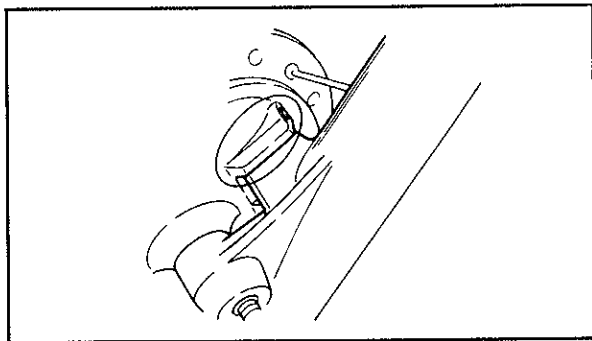

2. Always secure the front wheel axle as follows.
 - a. Torque the front axle nut.

Axle nut torque:
105 Nm (10,5 m · kg, 76,0 ft · lb)

b. Install a new cotter pin, discard old pin.

⚠ WARNING:

Always use a new cotter pin on the axle nut.

c. Adjust the play in the brake lever.

Rear wheel removal

1. Elevate the rear wheel by placing a suitable stand under the engine.
2. Remove the brake rod from the brake shoe plate. The brake rod can be removed by removing the adjuster

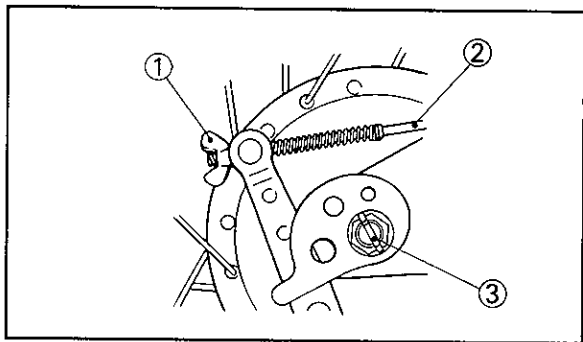

1 Adjuster 2 Brake rod 3 Cotter pin

3. Remove the cotter pin from the wheel axle and remove the rear wheel axle nut.
4. The rear wheel assembly, the collar, the chain puller(s), etc., can be removed from the motorcycle by pulling out the wheel axle.

NOTE:

A special tool is usually required for separating the chain; however, it is usually not necessary to unlink the chain to remove or reinstall the rear wheel.

Rear wheel installation

The rear wheel can be reassembled by reversing the disassembly procedure. Take the following steps:

1. When installing the chain, make certain closed end of master link clip is facing direction of rotation.

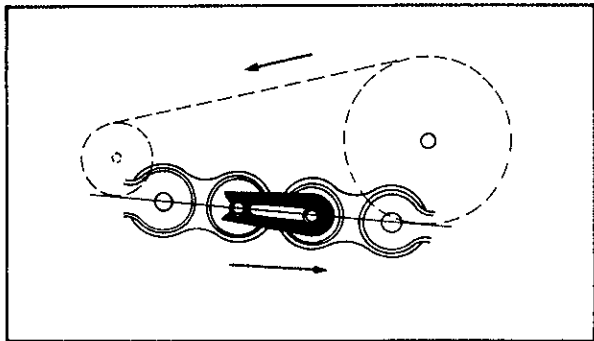

2. Check for proper engagement of the boss on swing arm with the locating slot on brake shoe plate

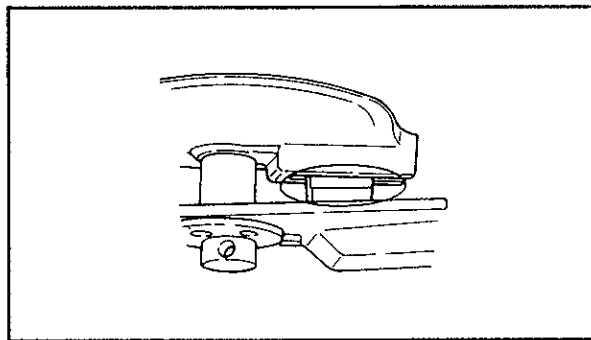

3. Make sure the rear wheel axle is inserted on the left-hand side and that the chain pullers are installed with the number punched side outward
4. Make sure the rear wheel axle nut is properly torqued.

Tightening torque:

105 Nm (10,5 m · kg, 76.0 ft · lb)

5. Adjust the drive chain tension.
6. Install a new cotter pin; discard old pins.

⚠WARNING: _____

Always use a new cotter pin on the axle nut.

7. Adjust the brake pedal and brake light switch.

⚠WARNING: _____

Check the operation of the brake light after adjusting the rear brake.

Troubleshooting

Although Yamaha motorcycles are given a rigid inspection before shipment from the factory, trouble may occur in operation. If this happens, check the motorcycle in accordance with the procedures given in the troubleshooting chart below. If repair is necessary, ask your Yamaha dealer

The skilled technicians at your Yamaha dealer provide excellent service. For replacement parts, use only genuine Yamaha Parts. Imitation parts are similar in shape but often inferior in quality of materials and workmanship, consequently, service life is shorter and more expensive repairs may be necessitated. Any fault in the fuel, compressing or ignition systems can cause poor starting or loss of power while riding. The troubleshooting chart describes quick and easy procedures for checking these systems.

Troubleshooting chart

⚠WARNING:

Never check the fuel system while smoking or in the vicinity of an open flame.

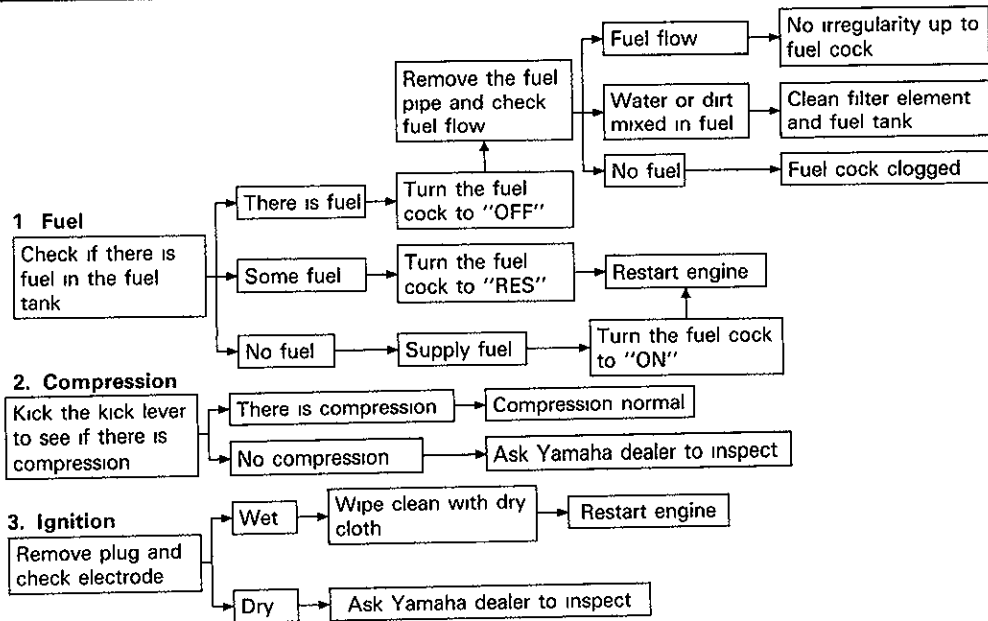

CLEANING AND STORAGE

A. CLEANING

Frequent thorough cleaning of your motorcycle will not only enhance its appearance but will improve general performance and extend the useful life of many components.

1. Before cleaning the motorcycle:
 - a. Block off end of exhaust pipe to prevent water entry; a plastic bag and strong rubber band may be used.
 - b. Remove air cleaner or protect it from water with plastic covering.
 - c. Make sure spark plug and fuel tank cap are properly installed.
2. If engine case is excessively greasy, apply degreaser with a paint brush. Do not apply degreaser to chain, sprockets, or wheel axles.
3. Rinse dirt and degreaser off with garden hose, using only enough hose pressure to do the job.

CAUTION

Excessive hose pressure may cause water seepage and contamination of wheel bearings, front forks, brakes, and transmission seals. Many expensive repair bills have resulted from improper high pressure detergent applications such as those available in coin-operated car washes.

4. Once the majority of the dirt has been hosed off, wash all surfaces with warm water and mild, detergent-type soap. An old tooth brush or bottle brush is handy to reach hard-to-get-to places.
5. Rinse motorcycle off immediately with clean water and dry all surfaces with a chamois, clean towel, or soft absorbent cloth.

6. Immediately after washing, remove excess moisture from chain and lubricate to prevent rust.
7. Clean the seat with a vinyl upholstery cleaner to keep the cover pliable and glossy.
8. Automotive-type wax may be applied to all painted and chrome-plated surfaces. Many contain abrasives which may mar paint or protective finish on fuel
9. After finishing, start the engine immediately and allow to idle for several minutes.

B. STORAGE

Long term storage (60 days or more) of your motorcycle will require some preventive procedures to insure against deterioration.

After cleaning motorcycle thoroughly, prepare for storage as follows:

1. Drain fuel tank, fuel lines, and carburetor float bowl.
2. Remove empty fuel tank, pour a cup of SAE 10W/30 motor oil in tank, shake tank to coat inner surfaces thoroughly and drain off excess oil. Re-install tank.
3. Remove spark plug, pour about one tablespoon of SAE 10W/30 motor oil in spark plug hole and re-install spark plug. Kick engine over several times (with ignition off) to coat cylinder walls with oil.
4. Remove drive chain. Clean thoroughly with solvent and lubricate. Re-install chain or store in a plastic bag (tie to frame for safe-keeping).
5. Lubricate all control cables.
6. Block up frame to raise both wheels off ground.
7. Tie a plastic bag over exhaust pipe outlet to prevent moisture from entering.

8. If storing in humid or salt-air atmosphere, coat all exposed metal surfaces with a light film of oil. Do not apply oil to rubber parts or seat cover.
9. Remove battery and charge. Store in a dry place and re-charge once a month. Do not store battery in an excessively warm or cold place (less than 0°C (30°F) or more than 30°C (90°F)).

NOTE: _____

Make any necessary repairs before storing the motorcycle.

SPECIFICATIONS

Model	XT250W
Dimension:	
Overall length	2,135 mm (84.1 in)
Overall width	890 mm (35.0 in)
Overall height	1,170 mm (46.1 in)
Seat height	840 mm (33.1 in)
Wheel base	1,400 mm (55.1 in)
Minimum ground clearance	250 mm (9.8 in)
Basic weight:	
With oil and full fuel tank	122 kg (269 lb)
Minimum turning radius:	2,200 mm (86.6 in)
Engine:	
Type	Air cooled 4-stroke, gasoline, SOHC
Model	3MG1
Cylinder arrangement	Single cylinder, Forward inclined
Displacement	249 cm ³
Bore × Stroke	75.0 × 56.5 mm (2.953 × 2.224 in)
Compression ratio	9.2 : 1
Starting system	Kick starter
Lubrication system	Wet sump

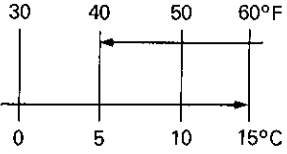
Model	XT250W
<p>Engine oil (4-cycle): Type</p>  <p>Capacity Periodic oil change Total amount</p>	<p>SAE 20W40 type SE motor oil (If temperature does not go below 5°C/40°F) SAE 10W30 type SE motor oil (If temperature does not go above 15°C/60°F)</p> <p>1.3 L (1.14 Imp qt, 1.37 US qt) 1.6 L (1.4 Imp qt, 1.7 US qt)</p>
<p>Air filter:</p>	<p>Wet type element</p>
<p>Fuel Type Tank capacity Reserve amount</p>	<p>Unleaded fuel only 8.0 L (2.1 Imp gal, 1.8 US gal) 1.7 L (0.37 Imp gal, 0.45 US gal)</p>
<p>Carburetor Type/Manufacturer</p>	<p>VM28SS, MIKUMI</p>
<p>Spark plug. Type/Manufacturer Gap</p>	<p>BP7ES/NGK 0.7~0.8 mm (0.028~0.031 in)</p>

Model	XT250W
Clutch type:	Wet, multi-disc
Transmission: Primary reduction system Primary reduction ratio Secondary reduction system Secondary reduction ratio Transmission type Operation	Helical gear 72/23 (3.130) Chain drive 47/15 (3.133) Constant mesh 5-speed Left foot operation
Gear ratio 1st 2nd 3rd 4th 5th	37/14 (2.642) 32/19 (1.684) 29/23 (1.260) 26/26 (1.000) 23/28 (0.821)
Chassis: Frame type Caster angle Trail	Diamond 29°15' 118 mm (4.65 in)

Model	XT250W
Tire: Type Size — Front Rear	With tube 3.00-21-4PR 4.60-17-4PR
Brake. Front brake type Operation Rear brake type Operation	Drum brake Right hand operation Drum brake Right foot operation
Suspension: Front Rear	Telescopic fork Swingarm (Monocross suspension)
Shock absorber: Front Rear	Coil spring, Oil damper Coil spring, Gas, Oil damper
Wheel travel: Front Rear	205 mm (8.07 in) 178 mm (7.01 in)

Model	XT250W
Electrical. Ignition system Generator system Battery type/capacity	CDI Flywheel magneto 6N6-3B/6V 6AH
Headlight type.	Bulb
Bulb wattage/quantity: Headlight Tail/brake light Flasher light Auxiliary light Meter light	6V 35W/35W 6V 5.3W/25W 6V 17W × 4 6V 3W 6V 3W × 2
Indicator light wattage/quantity: "NEUTRAL" "HIGH BEAM" "TURN"	6V 3W 6V 3W 6V 3W

NOISE REGULATION (For Australia)

“TAMPERING WITH NOISE CONTROL SYSTEM PROHIBITED”

Owners are warned that the law may prohibit:

- (a) The removal or rendering inoperative by any person other than for purposes of maintenance, repair or replacement, of any device or element of design incorporated into any new vehicle for the purpose of noise control prior to its sale or delivery to the ultimate purchaser or while it is in use; and
- (b) The use of the vehicle after such device or element of design has been removed or rendered inoperative by any person.

MEMO

MEMO



YAMAHA MOTOR CO.,LTD.

IWATA JAPAN

PRINTED IN JAPAN

88 8-0 25 x 1 ■

(英)

WIRING DIAGRAM

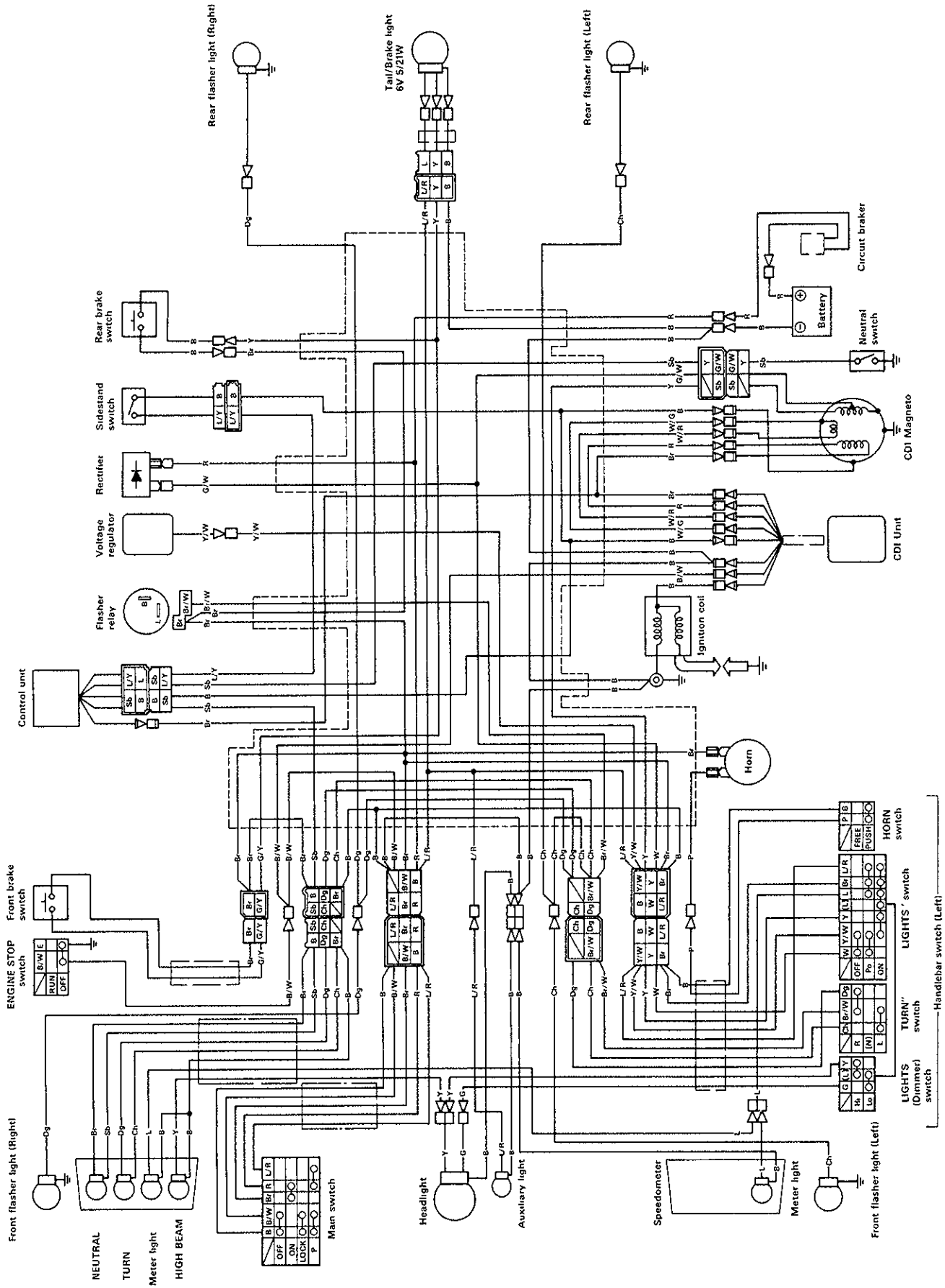

COLOR CODE

B	Black
Br	Brown
Ch	Chocolate
Dg	Dark green
G	Green
L	Blue
O	Orange
P	Pink
R	Red
Sb	Sky blue
W	White
Y	Yellow
B/W	Black/White
Br/W	Brown/White
G/W	Green/White
G/Y	Green/Yellow
L/Y	Blue/Yellow
L/R	Blue/Red
Y/W	Yellow/White
W/G	White/Green
W/R	White/Red