



OWNER'S MANUAL

Venture
XVZ13TFR

5JL-28199-24

Congratulations on your purchase of the Yamaha Royal Star™ VENTURE®. This model is the result of Yamaha's vast experience in the production of fine sporting, touring, and pacesetting racing machines. It represents the high degree of craftsmanship and reliability that have made Yamaha a leader in these fields.

This manual will give you an understanding of the operation, inspection, and basic maintenance of this motorcycle. If you have any questions concerning the operation or maintenance of your motorcycle, please consult a Yamaha dealer.

IMPORTANT MANUAL INFORMATION

EAU00005

Particularly important information is distinguished in this manual by the following notations.



The **Safety Alert Symbol** means **ATTENTION! BECOME ALERT! YOUR SAFETY IS INVOLVED!**



Failure to follow **WARNING** instructions could result in severe injury or death to the motorcycle operator, a bystander, or a person inspecting or repairing the motorcycle.



A **CAUTION** indicates special precautions that must be taken to avoid damage to the motorcycle.

NOTE:

A **NOTE** provides key information to make procedures easier or clearer.

NOTE:

- This manual should be considered a permanent part of this motorcycle and should remain with it even if the motorcycle is subsequently sold.
 - Yamaha continually seeks advancements in product design and quality. Therefore, while this manual contains the most current product information available at the time of printing, there may be minor discrepancies between your motorcycle and this manual. If you have any questions concerning this manual, please consult your Yamaha dealer.
-

IMPORTANT MANUAL INFORMATION

EW000002

 **WARNING**

PLEASE READ THIS MANUAL CAREFULLY AND COMPLETELY BEFORE OPERATING THIS MOTORCYCLE.

IMPORTANT MANUAL INFORMATION

EAU04229

XVZ13TFR

OWNER'S MANUAL

©2002 by Yamaha Motor Co., Ltd.

1st edition, April 2002

All rights reserved.

**Any reprinting or unauthorized use
without the written permission of
Yamaha Motor Co., Ltd.
is expressly prohibited.**

Printed in Japan.

1 SAFETY INFORMATION

1

2 DESCRIPTION

2

3 INSTRUMENT AND CONTROL FUNCTIONS

3

4 AUDIO SYSTEM

4

5 PRE-OPERATION CHECKS

5

6 OPERATION AND IMPORTANT RIDING POINTS

6

7 PERIODIC MAINTENANCE AND MINOR REPAIR

7

8 MOTORCYCLE CARE AND STORAGE

8

9 SPECIFICATIONS

9

10 CONSUMER INFORMATION

10

INDEX

Safe riding	1-1
Protective apparel	1-3
Modifications	1-3
Loading and accessories	1-3
Gasoline and exhaust gas	1-5
Location of important labels	1-7



MOTORCYCLES ARE SINGLE TRACK VEHICLES. THEIR SAFE USE AND OPERATION ARE DEPENDENT UPON THE USE OF PROPER RIDING TECHNIQUES AS WELL AS THE EXPERTISE OF THE OPERATOR. EVERY OPERATOR SHOULD KNOW THE FOLLOWING REQUIREMENTS BEFORE RIDING THIS MOTORCYCLE.

HE OR SHE SHOULD:

1. OBTAIN THOROUGH INSTRUCTIONS FROM A COMPETENT SOURCE ON ALL ASPECTS OF MOTORCYCLE OPERATION
2. OBSERVE THE WARNINGS AND MAINTENANCE REQUIREMENTS IN THE OWNER'S MANUAL.
3. OBTAIN QUALIFIED TRAINING IN SAFE AND PROPER RIDING TECHNIQUES
4. OBTAIN PROFESSIONAL TECHNICAL SERVICE AS INDICATED BY THE OWNER'S MANUAL AND/OR WHEN MADE NECESSARY BY MECHANICAL CONDITIONS.

Safe riding

1. Always make pre-operation checks. Careful checks may help prevent an accident.
2. This motorcycle is designed to carry the operator and a passenger
3. The failure of motorists to detect and recognize motorcycles in traffic is the predominating cause of automobile/motorcycle accidents. Many accidents have been caused by an automobile driver who did not see the motorcycle. Making yourself conspicuous appears to be very effective in reducing the chance of this type of accident.

Therefore:

- a. Wear a brightly colored jacket.
- b. Use extra caution when approaching and passing through intersections, since intersections are the most likely places for motorcycle accidents to occur.
- c. Ride where other motorists can see you. Avoid riding in another motorist's blind spot

4. Many motorcycle accidents involve inexperienced operators. In fact, many operators who have been involved in accidents do not even have a current motorcycle license.
 - a. Make sure that you are qualified and that you only lend your motorcycle to other qualified operators.
 - b. Know your skills and limits. Staying within your limits may help you to avoid an accident.
 - c. We recommend that you practice riding your motorcycle where there is no traffic until you have become thoroughly familiar with the motorcycle and all of its controls.
5. Many motorcycle accidents have been caused by error of the motorcycle operator. A typical error made by the operator is veering wide on a turn due to **EXCESSIVE SPEED** or undercornering (insufficient lean angle for the speed).
 - a. Always obey the speed limit and never travel faster than warranted by road and traffic conditions.
 - b. Always signal before turning or changing lanes. Make sure that other motorists can see you.
6. The posture of the operator and passenger is important for proper control.
 - a. The operator should keep both hands on the handlebar and both feet on the operator footrests during operation to maintain control of the motorcycle.
 - b. The passenger should always hold onto the operator, seat strap, or grab bar, if equipped, with both hands and keep both feet on the passenger footrests.
 - c. Never carry a passenger unless he or she can firmly place both feet on the passenger footrests.
7. Never ride under the influence of alcohol or other drugs.
8. This motorcycle is designed for on-road use only, therefore, it is not suitable for off-road use.

Protective apparel

The majority of fatalities from motorcycle accidents are the result of head injuries. The use of a safety helmet is the single most critical factor in the prevention or reduction of head injuries.

1. Always wear an approved helmet.
2. Wear a face shield or goggles. Wind in your unprotected eyes could contribute to an impairment of vision which could delay seeing a hazard.
3. The use of a jacket, heavy boots, trousers, gloves, etc., is effective in preventing or reducing abrasions or lacerations.
4. Never wear loose-fitting clothes, otherwise they could catch on the control levers, footrests, or wheels and cause injury or an accident.
5. Never touch the engine or exhaust system during or after operation. They become very hot and can cause burns. Always wear protective clothing that covers your legs, ankles, and feet.
6. Passengers should also observe the precautions mentioned above.

Modifications

Modifications made to this motorcycle not approved by Yamaha, or the removal of original equipment, may render the motorcycle unsafe for use and may cause severe personal injury. Modifications may also make your motorcycle illegal to use.

Loading and accessories

Adding accessories or cargo to your motorcycle can adversely affect stability and handling if the weight distribution of the motorcycle is changed. To avoid the possibility of an accident, use extreme caution when adding cargo or accessories to your motorcycle. Use extra care when riding a motorcycle that has added cargo or accessories. Here are some general guidelines to follow if loading cargo or adding accessories to your motorcycle:

Loading

The total weight of the operator, passenger, accessories and cargo must not exceed the maximum load limit of XVZ13TF: 190 kg. When loading within this weight limit, keep the following in mind

1. Cargo and accessory weight should be kept as low and close to the motorcycle as possible. Make sure to distribute the weight as evenly as possible on both sides of the motorcycle to minimize imbalance or instability.
2. Shifting weights can create a sudden imbalance. Make sure that accessories and cargo are securely attached to the motorcycle before riding. Check accessory mounts and cargo restraints frequently.
3. Never attach any large or heavy items to the handlebar, front fork, or front fender. These items, including such cargo as sleeping bags, duffel bags, or tents, can create unstable handling or slow steering response.

Accessories

Genuine Yamaha accessories have been specifically designed for use on this motorcycle. Since Yamaha cannot test all other accessories that may be available, you must personally be responsible for the proper selection, installation and use of non-Yamaha accessories. Use extreme caution when selecting and installing any accessories.

Keep the following guidelines in mind, as well as those provided under "Loading" when mounting accessories.

1. Never install accessories or carry cargo that would impair the performance of your motorcycle. Carefully inspect the accessory before using it to make sure that it does not in any way reduce ground clearance or cornering clearance, limit suspension travel, steering travel or control operation, or obscure lights or reflectors.



SAFETY INFORMATION

1

- a. Accessories fitted to the handlebar or the front fork area can create instability due to improper weight distribution or aerodynamic changes. If accessories are added to the handlebar or front fork area, they must be as lightweight as possible and should be kept to a minimum.
 - b. Bulky or large accessories may seriously affect the stability of the motorcycle due to aerodynamic effects. Wind may attempt to lift the motorcycle, or the motorcycle may become unstable in cross winds. These accessories may also cause instability when passing or being passed by large vehicles.
 - c. Certain accessories can displace the operator from his or her normal riding position. This improper position limits the freedom of movement of the operator and may limit control ability, therefore, such accessories are not recommended.
2. Use caution when adding electrical accessories. If electrical accessories exceed the capacity of the motorcycle's electrical system, an electric failure could result, which could cause a dangerous loss of lights or engine power.

Gasoline and exhaust gas

1. GASOLINE IS HIGHLY FLAMMABLE:
 - a. Always turn the engine off when refueling.
 - b. Take care not to spill any gasoline on the engine or exhaust system when refueling.
 - c. Never refuel while smoking or in the vicinity of an open flame.
2. Never start the engine or let it run for any length of time in a closed area. The exhaust fumes are poisonous and may cause loss of consciousness and death within a short time. Always operate your motorcycle in an area that has adequate ventilation.
3. Always turn the engine off before leaving the motorcycle unattended and remove the key from the main switch. When parking the motorcycle, note the following:

SAFETY INFORMATION

- a. The engine and exhaust system may be hot, therefore, park the motorcycle in a place where pedestrians or children are not likely to touch these hot areas.
 - b. Do not park the motorcycle on a slope or soft ground, otherwise it may fall over.
 - c. Do not park the motorcycle near a flammable source (e.g. a kerosene heater, or near an open flame), otherwise it could catch fire.
4. When transporting the motorcycle in another vehicle, make sure that it is kept upright and that the fuel cock is turned to "ON" or "RES" (for vacuum type) / "OFF" (for manual type). If it should lean over, gasoline may leak out of the carburetor or fuel tank.
 5. If you should swallow any gasoline, inhale a lot of gasoline vapor, or allow gasoline to get into your eyes, see your doctor immediately. If any gasoline spills on your skin or clothing, immediately wash the affected area with soap and water and change your clothes.

SAFETY INFORMATION

EAU01277

Location of important labels

Please read the following important label carefully before operating this motorcycle.

1

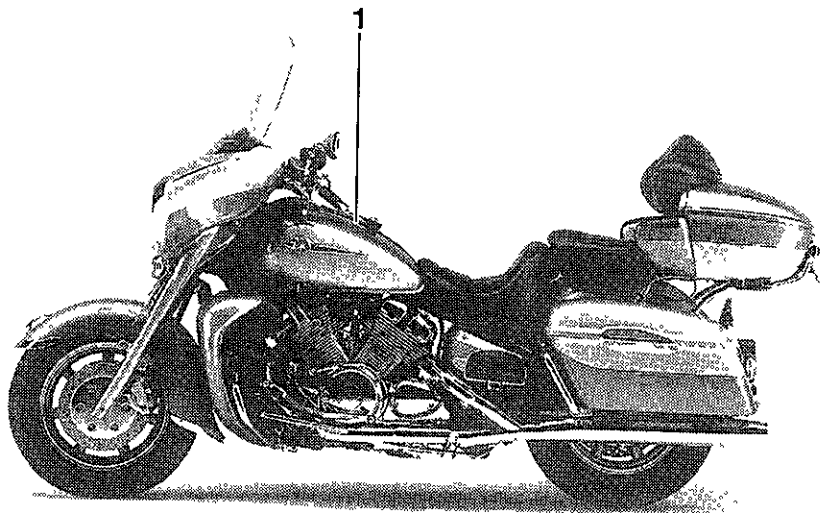

1

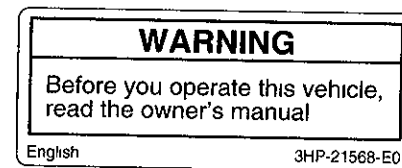

Left view	2-1
Right view	2-2
Controls and instruments	2-3

DESCRIPTION

E-AU00026

Royal Star™ VENTURE®

Left view

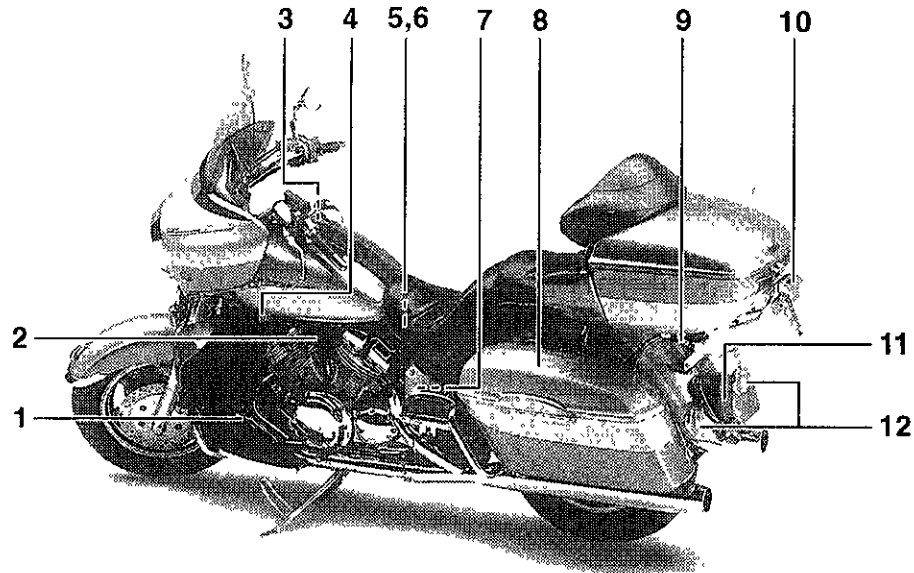

- | | | | |
|-------------------------|-------------|----------------------------|-------------|
| 1. Shift pedal | (page 3-9) | 7 Fuse box 2 | (page 7-34) |
| 2. Starter (choke) knob | (page 3-13) | 8 Side case | (page 3-15) |
| 3. Fuel tank cap | (page 3-10) | 9. Helmet holder | (page 3-14) |
| 4. Fuel cock | (page 3-12) | 10. Licence light | (page 7-37) |
| 5. Battery | (page 7-33) | 11 Tail/brake light | (page 7-37) |
| 6. Coolant reservoir | (page 7-15) | 12 Rear turn signal lights | (page 7-37) |

Royal Star™ VENTURE®

Right view

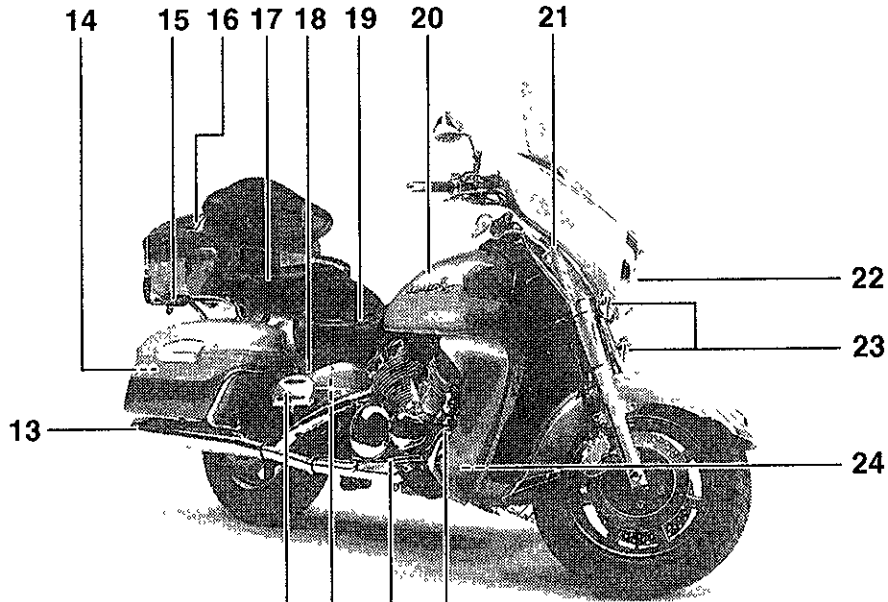

13. Muffler

14. Owner's tool kit

15. Helmet holder

16. Travel trunk

17. Passenger seat

18. Shock absorber assembly air valve

19. Rider seat

20. Fuel tank

28 27 26 25

(page 7-1)

(page 3-14)

(page 3-16)

(page 3-18)

(page 3-13)

(page 3-11)

21. Front fork air valve

22. Headlight

23. Front turn signal lights

24. Fuse box 1

25. Brake pedal

26. Rider footrest

27. Coolant reservoir

28. Passenger footrest

(page 3-17)

(page 7-36)

(page 7-37)

(page 7-34)

(page 3-10)

(page 7-15)

DESCRIPTION

Royal Star™ VENTURE® Controls and instruments

2

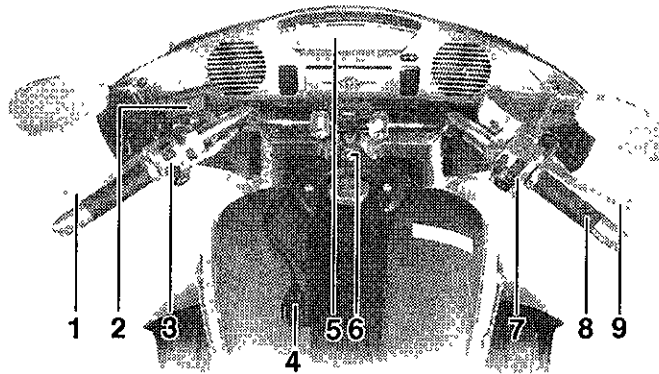

- 1. Clutch lever
- 2. Audio system control unit
- 3. Left handlebar switches
- 4 Rider headset jack
- 5. Speedometer unit

(page 3-9)
(page 4-3)
(page 3-7)
(page 4-2)
(page 3-4)

- 6 Main switch/steering lock
- 7. Right handlebar switches
- 8. Throttle grip
- 9. Brake lever

(page 3-1)
(page 3-8)
(page 7-19)
(page 3-9)

INSTRUMENT AND CONTROL FUNCTIONS

Main switch/steering lock	3-1	Starter (choke) knob	3-13
Indicator and warning lights	3-2	Locking the steering with a padlock	3-13
Speedometer unit	3-4	Rider seat	3-13
Cruise control system	3-5	Helmet holders	3-14
Fuel gauge	3-7	Side cases and travel trunk	3-15
Handlebar switches	3-7	Adjusting the front fork	3-17
Clutch lever	3-9	Adjusting the shock absorber assembly	3-18
Shift pedal	3-9	Locks for the optional side cases and travel trunk	3-19
Brake lever	3-9	Sidestand	3-19
Brake pedal	3-10	Ignition circuit cut-off system	3-20
Fuel tank cap	3-10	Auxiliary DC jack and terminals	3-22
Fuel	3-11		
Fuel cock	3-12		

INSTRUMENT AND CONTROL FUNCTIONS

EAU00027

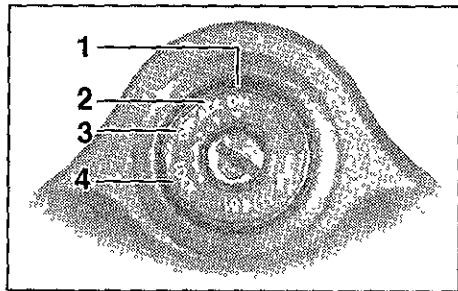

- 1 ON
- 2. ACC (Accessory)
- 3. OFF
- 4 LOCK

Main switch/steering lock

EAU00029

The main switch/steering lock controls the ignition and lighting systems, and is used to lock the steering. The various positions are described below

ON

EAU00031

All electrical systems are supplied with power, and the headlight, meter lighting, taillight and license plate light come on, and the engine can be started. The key cannot be removed.

ACC (Accessory)

EAU01842

The audio system and the auxiliary DC jack and terminals can be used in this position. Therefore, do not use the accessory position for an extended period of time, otherwise the battery may discharge.

The key cannot be removed.

OFF

EAU00038

All electrical systems are off. The key can be removed.

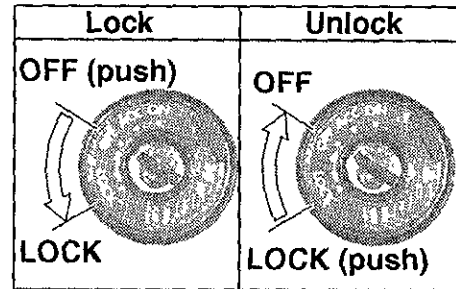

LOCK

EAU00040

The steering is locked, and all electrical systems are off. The key can be removed.

To lock the steering

1. Turn the handlebars all the way to the left.
2. Push the key in from the "OFF" position, and then turn it to "LOCK" while still pushing it.
3. Remove the key.

To unlock the steering

Push the key in, and then turn it to "OFF" while still pushing it.

INSTRUMENT AND CONTROL FUNCTIONS

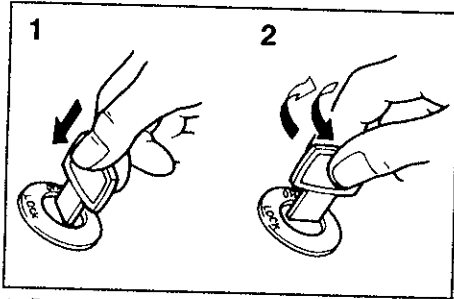

- 1 Push
- 2 Turn

EW000016

⚠ WARNING

Never turn the key to “OFF” or “LOCK” while the motorcycle is moving, otherwise the electrical systems will be switched off, which may result in loss of control or an accident. Make sure that the motorcycle is stopped before turning the key to “OFF” or “LOCK”.

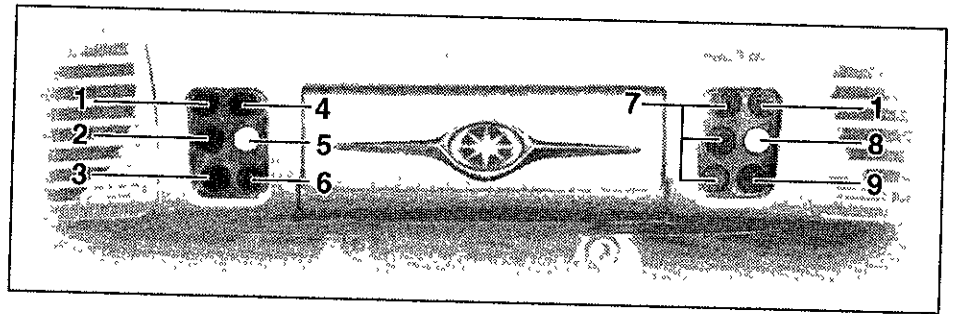

3

Indicator and warning lights

EAU03034

EAU03201

1. Turn signal indicator lights “←” and “→”

EAU04121

The corresponding indicator light flashes when the turn signal switch is pushed to the left or right.

2. High beam indicator light “≡○”

EAU00063

This indicator light comes on when the high beam of the headlight is switched on.

3. Oil level warning light “ ”

This warning light comes on when the engine oil level is low.

The electrical circuit of the warning light can be checked according to the following procedure.

- 1 Set the engine stop switch to “ ” and turn the key to “ON”.
- 2 Shift the transmission into the neutral position or pull the clutch lever.
- 3 Push the start switch. If the warning light does not come on while pushing the start switch, have a Yamaha dealer check the electrical circuit.

INSTRUMENT AND CONTROL FUNCTIONS

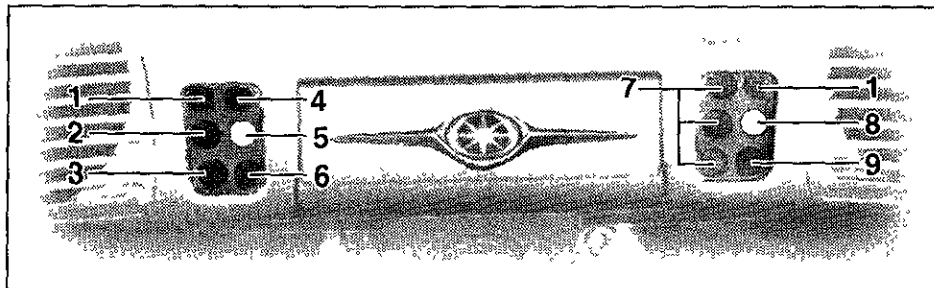

3

NOTE:

Even if the oil level is sufficient, the warning light may flicker when riding on a slope or during sudden acceleration or deceleration, but this is not a malfunction.

4. Overdrive indicator light "O/D"

This indicator light comes on when the transmission is in overdrive (5th gear).

5. Engine trouble warning light

""

This warning light comes on or flashes when an electrical circuit monitoring the engine is defective. When this occurs, have a Yamaha dealer check the self-diagnosis system.

6. Fuel level warning light ""

This warning light comes on when the fuel level drops below approximately 3.5 L. When this occurs, turn the fuel cock lever to the "RES" position and refuel as soon as possible.

7. Cruise control indicator lights

See page 3-5 for an explanation of these indicator lights.

8. Neutral indicator light "N"

This indicator light comes on when the transmission is in the neutral position.

INSTRUMENT AND CONTROL FUNCTIONS

EAU01707

9. Coolant temperature warning light “”

This warning light comes on when the engine overheats. When this occurs, stop the engine immediately and allow the engine to cool.

The electrical circuit of the warning light can be checked according to the following procedure.

1. Set the engine stop switch to “” and turn the key to “ON”
2. Shift the transmission into the neutral position or pull the clutch lever.
3. Push the start switch. If the warning light does not come on while pushing the start switch, have a Yamaha dealer check the electrical circuit.

EC000002

CAUTION:

Do not operate the engine if it is overheated.

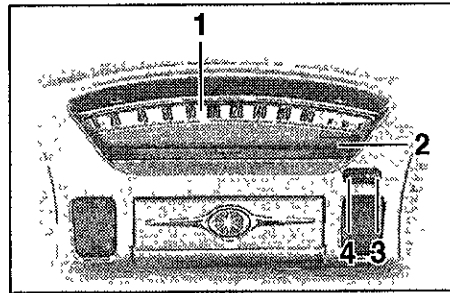

- 1 Speedometer
- 2 Odometer/tripmeter/clock
- 3 “RESET” button
- 4 “SELECT” button

EAU03565

Speedometer unit

The speedometer unit is equipped with the following:

- a digital speedometer (which shows riding speed)
- an odometer (which shows the total distance traveled)
- two tripmeters (which show the distance traveled since they were last set to zero)
- a fuel reserve tripmeter (which shows the distance traveled on the fuel reserve)
- a clock

Odometer and tripmeter modes

Pushing the “SELECT” button switches the display between the odometer mode “ODO” and the tripmeter modes “TRIP 1” and “TRIP 2” in the following order:

ODO → TRIP 1 → TRIP 2 → ODO

If the fuel level warning light comes on (see page 3-3), the odometer display will automatically change to the fuel reserve tripmeter mode “TRIP F” and start counting the distance traveled from that point. In that case, pushing the “SELECT” button switches the display between the various tripmeter and odometer modes in the following order: TRIP F → TRIP 1 → TRIP 2 → ODO → TRIP F

INSTRUMENT AND CONTROL FUNCTIONS

3

To reset a tripmeter, select it by pushing the “SELECT” button, and then push the “RESET” button. If you do not reset the fuel reserve tripmeter manually, it will reset itself automatically and the display will return to “TRIP 1” after refueling and traveling 5 km.

NOTE:

After resetting the fuel reserve tripmeter, the display will return to “TRIP 1”, unless a different mode had been previously selected, in that case, the display automatically returns to the prior mode

Clock mode

To change the display to the clock mode, push both the “SELECT” and “RESET” buttons.

To change the display back to the odometer modes, push the “SELECT” button

To set the clock.

1. Push both the “SELECT” and “RESET” buttons for at least two seconds.
2. When the hour digits start flashing, push the “RESET” button to set the hours
3. Push the “SELECT” button, and the minute digits will start flashing.
4. Push the “RESET” button to set the minutes
5. Push the “SELECT” button to start the clock

NOTE:

After setting the clock, be sure to push the “SELECT” button before turning the key to “OFF”, otherwise the clock will not be set.

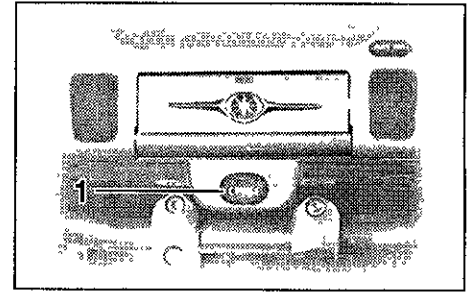

1 “CRUISE” switch

EAU04037

Cruise control system

This motorcycle is equipped with a cruise control system designed to maintain a set traveling speed.

Activating and setting the cruise control system

The cruise control system can only be activated when riding in 4th or 5th gear at speeds between 50 km/h and 130 km/h.

INSTRUMENT AND CONTROL FUNCTIONS

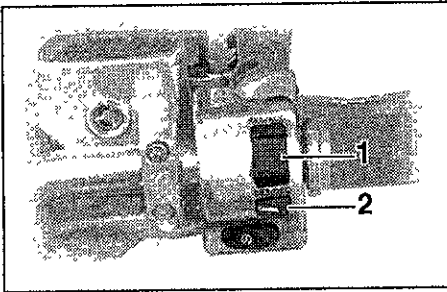

- 1 Cruise control switch
- 2 "CANCEL" switch

To activate and set the cruise control system.

- 1 Push the "CRUISE" switch to the left. The "ON" indicator light will come on.
2. Press the "SET/DEC" (set/decelerate) side of the cruise control switch to activate the cruise control system. The "SET" indicator light comes on.
3. Set the desired traveling speed as follows. Press the "RES/ACC" (resume/accelerate) side of the cruise control switch to increase the set speed or the "SET/DEC" side to decrease the speed.

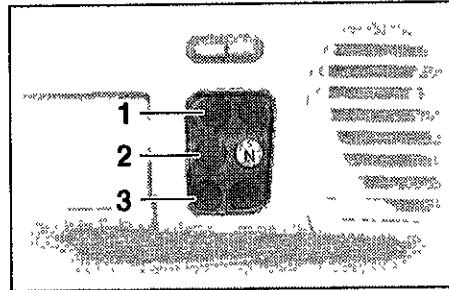

- 1 "SET" indicator light
- 2 "RES" indicator light
- 3 "ON" indicator light

NOTE:

Pressing the cruise control switch once will change the speed in increments of 1.6 km/h. Holding the cruise control switch down will increase or decrease the speed continuously until the switch is released.

The traveling speed can be set to a maximum of 130 km/h and a minimum of 50 km/h.

When the cruise control system is activated and the throttle grip is turned to increase the speed by up to 8 km/h, the cruise control system will return to the

set speed after the throttle grip is released. However, if the speed is increased by more than 8 km/h, the cruise control system will be deactivated until the traveling speed is within 8 km/h of the set speed.

Deactivating the cruise control system

Applying the front or rear brake or disengaging the clutch will automatically deactivate the cruise control system. Push the "CANCEL" switch to manually deactivate cruise control.

NOTE:

- When the cruise control system is deactivated, the "RES" (resume) indicator light will come on.
- Traveling speed decreases as soon as the cruise control system is deactivated; unless the throttle grip is turned

INSTRUMENT AND CONTROL FUNCTIONS

3

Push the "RES/ACC" side of the cruise control switch to reactivate the system. The traveling speed will return to the previously set speed. The "RES" indicator light will flash during this time and then go off. Once the cruise control system is reactivated, the "SET" indicator light will come on.

Push the "CRUISE" switch to the right to turn the cruise control system off completely.

EWA00019

! WARNING

If the cruise control system is defective, the "SET" and "RES" indicator lights will flash simultaneously. If this occurs, turn the cruise control system off and have a Yamaha dealer check it.

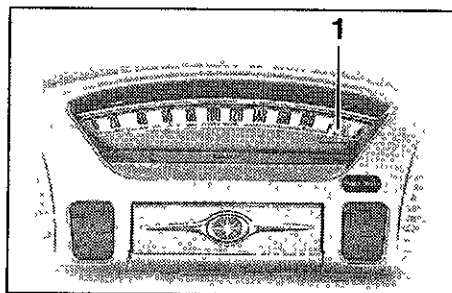

1 Fuel gauge

EAU01779

Fuel gauge

The fuel gauge indicates the amount of fuel in the fuel tank. The display segments of the fuel gauge disappear towards "E" (Empty) as the fuel level decreases. When only one segment is left near "E", refuel as soon as possible.

NOTE:

This fuel gauge is equipped with a self-diagnosis system. If the electrical circuit is defective, first the display segments and then either "E" or "F" will flash. If this occurs, have a Yamaha dealer check the electrical circuit.

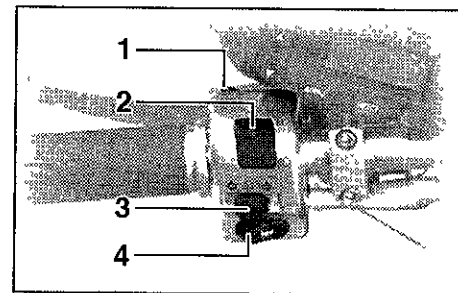

EAU00118

Handlebar switches

EAU00119

1. Pass switch "≡○"

Press this switch to flash the headlight.

EAU03888



2. Dimmer switch "≡○/≡○"

Set this switch to "≡○" for the high beam and to "≡○" for the low beam.

INSTRUMENT AND CONTROL FUNCTIONS

3. Turn signal switch “/”

EAU03889

To signal a right-hand turn, push this switch to “”. To signal a left-hand turn, push this switch to “”. When released, the switch returns to the center position. To cancel the turn signal lights, push the switch in after it has returned to the center position.

4. Horn switch “”

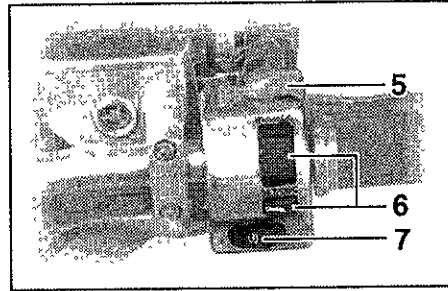

EAU00129

Press this switch to sound the horn.



5. Engine stop switch “/”

EAU03890

Set this switch to “” before starting the engine. Set this switch to “” to stop the engine in case of an emergency, such as when the motorcycle overturns or when the throttle cable is stuck.

6. Cruise control switches

EAU01859

See page 3-5 for an explanation of the cruise control system.

7. Start switch “”

EAU00143

Push this switch to crank the engine with the starter.

EC000005

CAUTION

See page 6-1 for starting instructions prior to starting the engine.

INSTRUMENT AND CONTROL FUNCTIONS

3

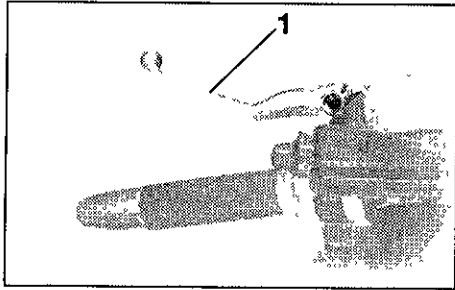

1 Clutch lever

EAU00152

Clutch lever

The clutch lever is located at the left handlebar grip. To disengage the clutch, pull the lever toward the handlebar grip. To engage the clutch, release the lever. The lever should be pulled rapidly and released slowly for smooth clutch operation.

The clutch lever is equipped with a clutch switch, which is part of the ignition circuit cut-off system. (See page 3-20 for an explanation of the ignition circuit cut-off system.)

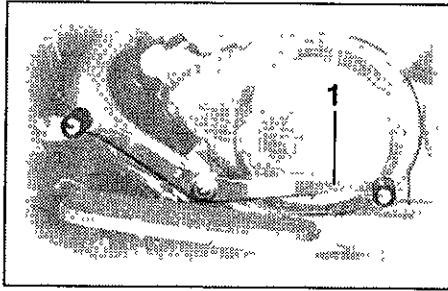

1 Shift pedal

EAU01215

Shift pedal

The shift pedal is located on the left side of the engine and is used in combination with the clutch lever when shifting the gears of the 5-speed constant-mesh transmission equipped on this motorcycle.

NOTE: _____
Use your toes or heel to shift up and your toes to shift down

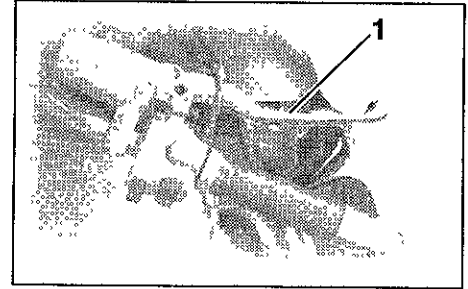

1 Brake lever

EAU00158

Brake lever

The brake lever is located at the right handlebar grip. To apply the front brake, pull the lever toward the handlebar grip.

INSTRUMENT AND CONTROL FUNCTIONS

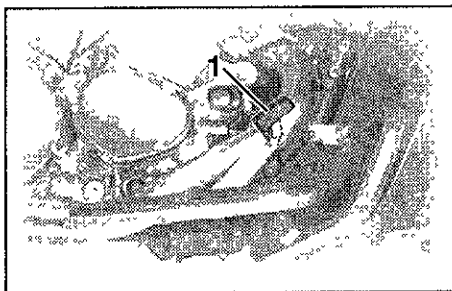

1 Brake pedal

EAU00162

Brake pedal

The brake pedal is on the right side of the motorcycle. To apply the rear brake, press down on the brake pedal.

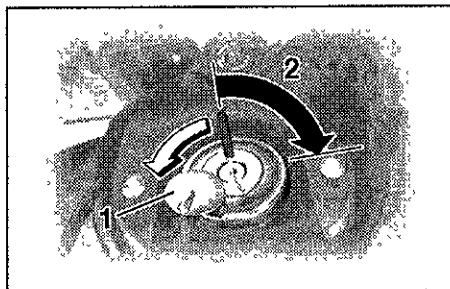

1 Fuel tank cap lock cover
2 Unlock

EAU02917

Fuel tank cap

To remove the fuel tank cap

Slide the lock cover open, insert the key into the lock, and then turn it 1/4 turn clockwise. The lock will be released and the fuel tank cap can be removed.

To install the fuel tank cap

- 1 Insert the fuel tank cap into the tank opening with the key inserted in the lock and with the “△” mark facing forward

- 2 Turn the key counterclockwise to the original position, remove it, and then close the lock cover

NOTE:

The fuel tank cap cannot be installed unless the key is in the lock. In addition, the key cannot be removed if the cap is not properly installed and locked.

EW000024

WARNING

Make sure that the fuel tank cap is properly installed before riding.

INSTRUMENT AND CONTROL FUNCTIONS

3

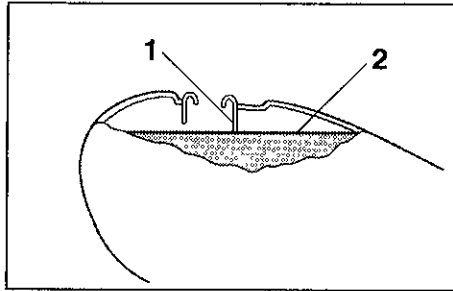

- 1 Fuel tank filler tube
2 Fuel level

EAU03753

Fuel

Make sure that there is sufficient fuel in the tank. Fill the fuel tank to the bottom of the filler tube as shown.

EW000130

⚠ WARNING

- Do not overfill the fuel tank, otherwise it may overflow when the fuel warms up and expands.
- Avoid spilling fuel on the hot engine.

EAU00185

CAUTION:

Immediately wipe off spilled fuel with a clean, dry, soft cloth, since fuel may deteriorate painted surfaces or plastic parts.

EAU04312

Recommended fuel
UNLEADED GASOLINE ONLY
Fuel tank capacity.
Total amount
22.5 L
Reserve amount
3.5 L

ECA00104

CAUTION:

Use only unleaded gasoline. The use of leaded gasoline will cause severe damage to internal engine parts, such as the valves and piston rings, as well as to the exhaust system.

Your Yamaha engine has been designed to use regular unleaded gasoline with a research octane number of 91 or higher. If knocking (or pinging) occurs, use a gasoline of a different brand or premium unleaded fuel. Use of unleaded fuel will extend spark plug life and reduce maintenance costs.

INSTRUMENT AND CONTROL FUNCTIONS

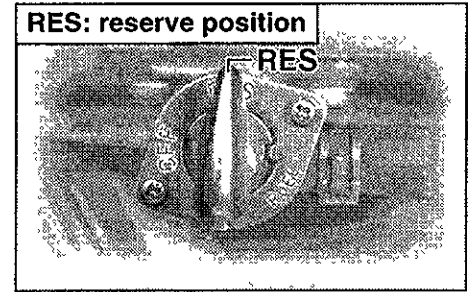
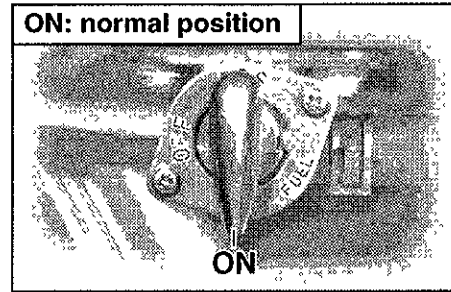
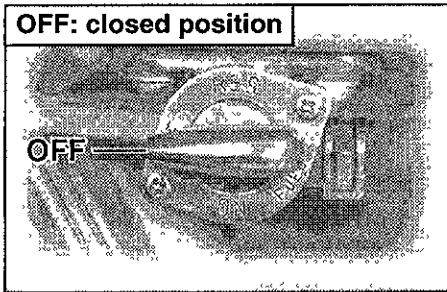

3

Fuel cock

EAU02969

The fuel cock supplies fuel from the tank to the carburetors while also filtering it.

The fuel cock lever positions are explained as follows and shown in the illustrations

OFF

With the fuel cock lever in this position, fuel will not flow. Always turn the fuel cock lever to this position when the engine is not running.

ON

With the fuel cock lever in this position, fuel flows to the carburetors. Turn the fuel cock lever to this position when starting the engine and riding.

RES

This indicates reserve. With the fuel cock lever in this position, the fuel reserve is made available. Turn the fuel cock lever to this position if you run out of fuel while riding. When this occurs, refuel as soon as possible and be sure to turn the fuel cock lever back to "ON"!

INSTRUMENT AND CONTROL FUNCTIONS

3

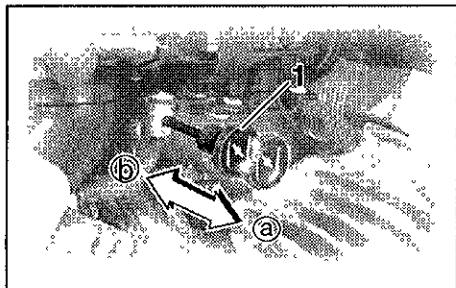

1 Starter (choke) knob “|↘|”

EAU04038

Starter (choke) knob “|↘|”

Starting a cold engine requires a richer air-fuel mixture, which is supplied by the starter (choke).

Move the knob in direction (a) to turn on the starter (choke).

Move the knob in direction (b) to turn off the starter (choke)

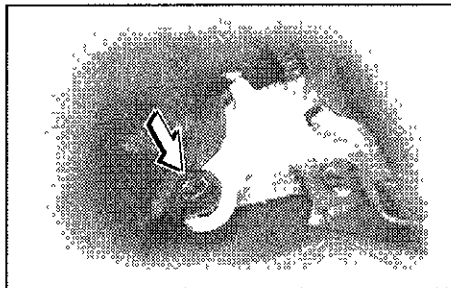

EAU03372

Locking the steering with a padlock

In addition to the main switch/steering lock, there are brackets on the right side of the steering head pipe for locking the steering with a padlock. To do so, turn the handlebar until the holes in the two brackets are aligned, and then lock the steering with a suitable padlock.

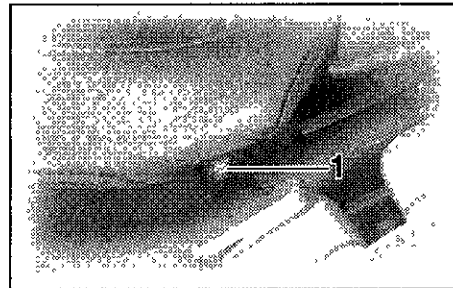

1 Nut (x 2)

FAU01781

Rider seat

To remove the rider seat

Remove the nuts, and then pull the rider seat up

INSTRUMENT AND CONTROL FUNCTIONS

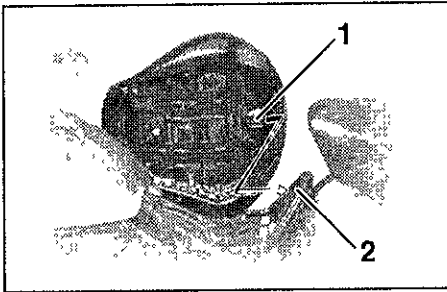

- 1 Projection
- 2 Seat holder

To install the rider seat

Insert the projection on the rear of the rider seat into the seat holder as shown, place the seat in the original position, and then tighten the nuts

NOTE:

Make sure that the rider seat is properly secured before riding.

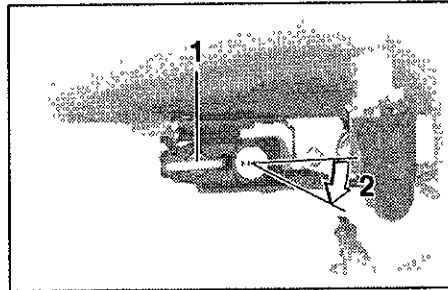

- 1 Helmet holder (right)
- 2 Unlock

Helmet holders

To open a helmet holder

Insert the key into the helmet holder lock, and then turn it as shown

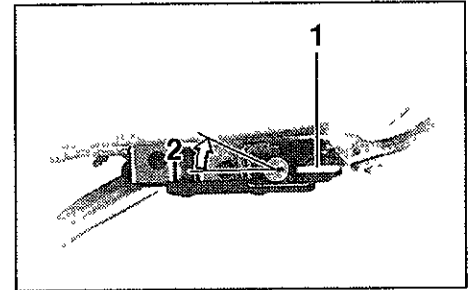

- 1 Helmet holder (left)
- 2 Unlock

To close a helmet holder

Place the helmet holder in the original position, and then remove the key.

EWA00015

! WARNING

Never ride with a helmet attached to a helmet holder, since the helmet may hit objects, causing loss of control and possibly an accident.

INSTRUMENT AND CONTROL FUNCTIONS

3

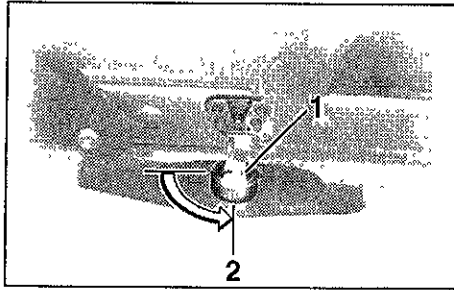

- 1 Side case lock
- 2 Unlock

EAU01866

Side cases and travel trunk

EWA00021

⚠ WARNING

Improper loading or overloading can cause loss of control and possibly an accident or personal injury. See pages 7-20 for important loading and tire pressure information.

- Always securely close the side cases and travel trunk before riding.
- Distribute weight evenly on each side of the motorcycle.

- Do not exceed the load limit of 9 kg for each side case and the travel trunk.
- Do not exceed the maximum load of 190 kg for the vehicle.
- Do not exceed 120 km/h when riding with the travel trunk, side cases or both installed, otherwise handling could be affected. Improper loading, poor tire or overall motorcycle conditions, poor road surfaces or adverse weather conditions may make it necessary to further reduce the riding speed.

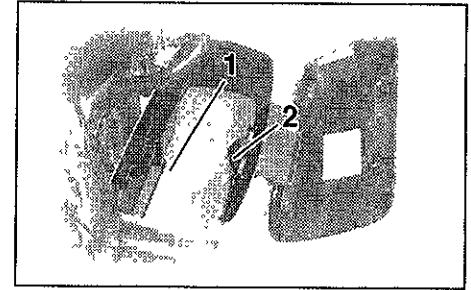

- 1 Storage compartment
- 2 Storage pouch

Side cases

To open a side case

1. Insert the key into the lock, turn it counterclockwise, and then push it in.
2. Fold the side case lid up

To close a side case

1. Fold the side case lid down.
2. Turn the key clockwise, and then remove it

NOTE:

Push both sides of the lid down so that both latches snap into place

INSTRUMENT AND CONTROL FUNCTIONS

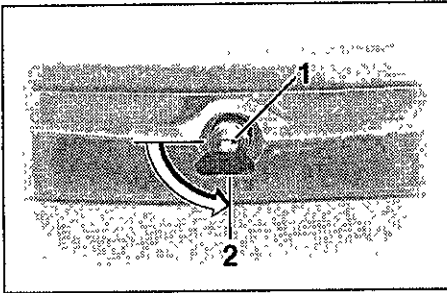

- 1 Travel trunk lock
- 2 Unlock

Travel trunk

To open the travel trunk

1. Insert the key into the lock, turn it counterclockwise, and then push it in.

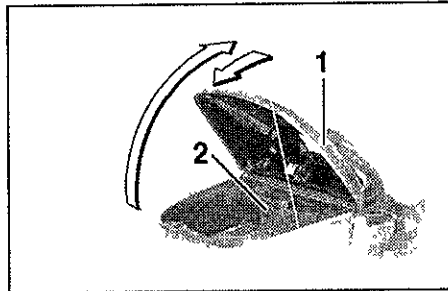

- 1 Lid resting in opened position
- 2 Storage pouch

2. Fold the travel trunk lid up, and then release it so that it will rest in place as shown

ECA00029

CAUTION:

Do not apply excessive pressure on the travel trunk lid when it is open.

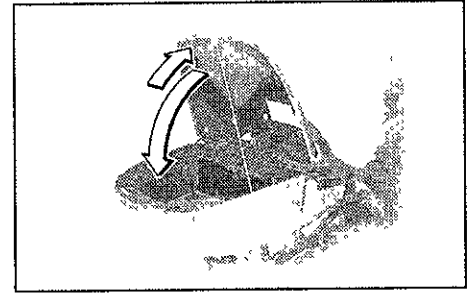

To close the travel trunk

- 1 Fold the travel trunk lid up completely, and then fold it down.

INSTRUMENT AND CONTROL FUNCTIONS

3

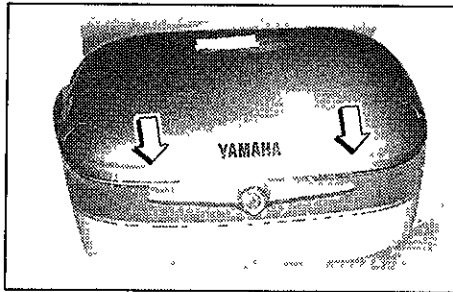

NOTE: _____
Push both sides of the lid down so that both latches snap into place

- 2 Turn the key clockwise, and then remove it

ECA00030

CAUTION: _____
To avoid locking the key in, never lock either side case or the travel trunk and remove the key from the lock before closing the lid.

Adjusting the front fork

EAU03719*

This front fork is equipped with air valves for adjusting the spring rate.

EW000035

! WARNING

Always adjust both fork legs equally, otherwise poor handling and loss of stability may result.

Adjust the spring rate as follows

1. Place the motorcycle on the side-stand

NOTE: _____
When checking and adjusting the air pressure, there should be no weight on the motorcycle.

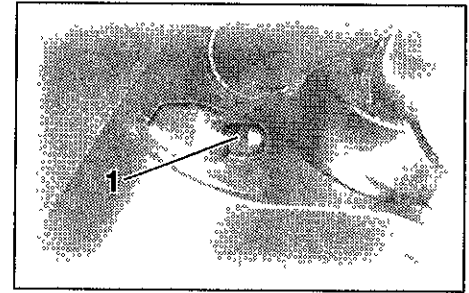

1 Front fork air valve cap

- 2 Remove the air valve cap from each fork leg.
3. Check the air pressure in each fork leg with the air pressure gauge included in the owner's tool kit.
4. To increase the spring rate and thereby harden the suspension, increase the air pressure with an air pump. To decrease the spring rate and thereby soften the suspension, decrease the air pressure by pushing each valve stem down.

INSTRUMENT AND CONTROL FUNCTIONS

Spring rate:

Minimum (soft)/standard.

Air pressure =

0 kPa (0 kgf/cm², 0 bar)

Maximum (hard):

Air pressure =

50 kPa (0.5 kgf/cm², 0.5 bar)

EC000012

CAUTION:

Never exceed the maximum air pressure, otherwise the front fork oil seals may become damaged.

- 5 Securely install the air valve caps

EAU03721*

Adjusting the shock absorber assembly

This shock absorber assembly is equipped with an air valve for adjusting the spring rate.

EC000015

CAUTION:

Never attempt to turn an adjusting mechanism beyond the maximum or minimum settings.

Adjust the spring rate as follows

1. Place the motorcycle on the side-stand

NOTE:

When checking and adjusting the air pressure, there should be no weight on the motorcycle

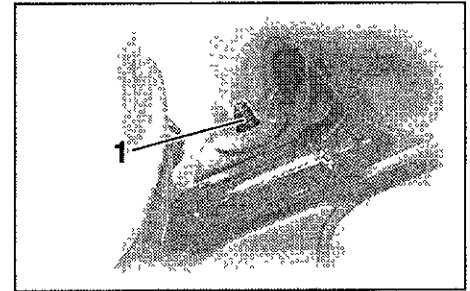

- 1 Shock absorber assembly air valve cap
2. Remove the air valve cap.
3. Check the air pressure with the air pressure gauge included in the owner's tool kit.
4. To increase the spring rate and thereby harden the suspension, increase the air pressure with an air pump. To decrease the spring rate and thereby soften the suspension, decrease the air pressure by pushing the valve stem down

3

INSTRUMENT AND CONTROL FUNCTIONS

3

Spring rate

Minimum (soft)/standard:

Air pressure =

0 kPa (0 kgf/cm², 0 bar)

Maximum (hard)

Air pressure =

400 kPa (4.0 kgf/cm², 4.0 bar)

ECA00050

CAUTION:

Never exceed the maximum air pressure, otherwise the oil seal may become damaged.

5. Securely install the air valve cap.

EAU04043

Locks for the optional side cases and travel trunk

There are three locks in a plastic bag located beside the owner's tool kit. When used to replace the locks of the optional side cases and travel trunk, which can be obtained at a Yamaha dealer, these locks can be operated with the ignition key. Keep these locks in a safe place to prevent losing them.

EAU00330

Sidestand

The sidestand is located on the left side of the frame. Raise the sidestand or lower it with your foot while holding the motorcycle upright.

NOTE:

The built-in sidestand switch is part of the ignition circuit cut-off system, which cuts the ignition in certain situations. (See further down for an explanation of the ignition circuit cut-off system.)

EW000044

EAU03720

WARNING

The motorcycle must not be ridden with the sidestand down, or if the sidestand cannot be properly moved up (or does not stay up), otherwise the sidestand could contact the ground and distract the operator, resulting in a possible loss of control. Yamaha's ignition circuit cut-off system has been designed to assist the operator in fulfilling the responsibility of raising the sidestand before starting off. Therefore, check this system regularly as described below and have a Yamaha dealer repair it if it does not function properly.

Ignition circuit cut-off system

The ignition circuit cut-off system (comprising the sidestand switch, clutch switch and neutral switch) has the following functions

- It prevents starting when the transmission is in gear and the sidestand is up, but the clutch lever is not pulled.
- It prevents starting when the transmission is in gear and the clutch lever is pulled, but the sidestand is still down
- It cuts the running engine when the transmission is in gear and the sidestand is moved down.

Periodically check the operation of the ignition circuit cut-off system according to the following procedure.

EW000045

WARNING

If a malfunction is noted, have a Yamaha dealer check the system before riding.

INSTRUMENT AND CONTROL FUNCTIONS

3

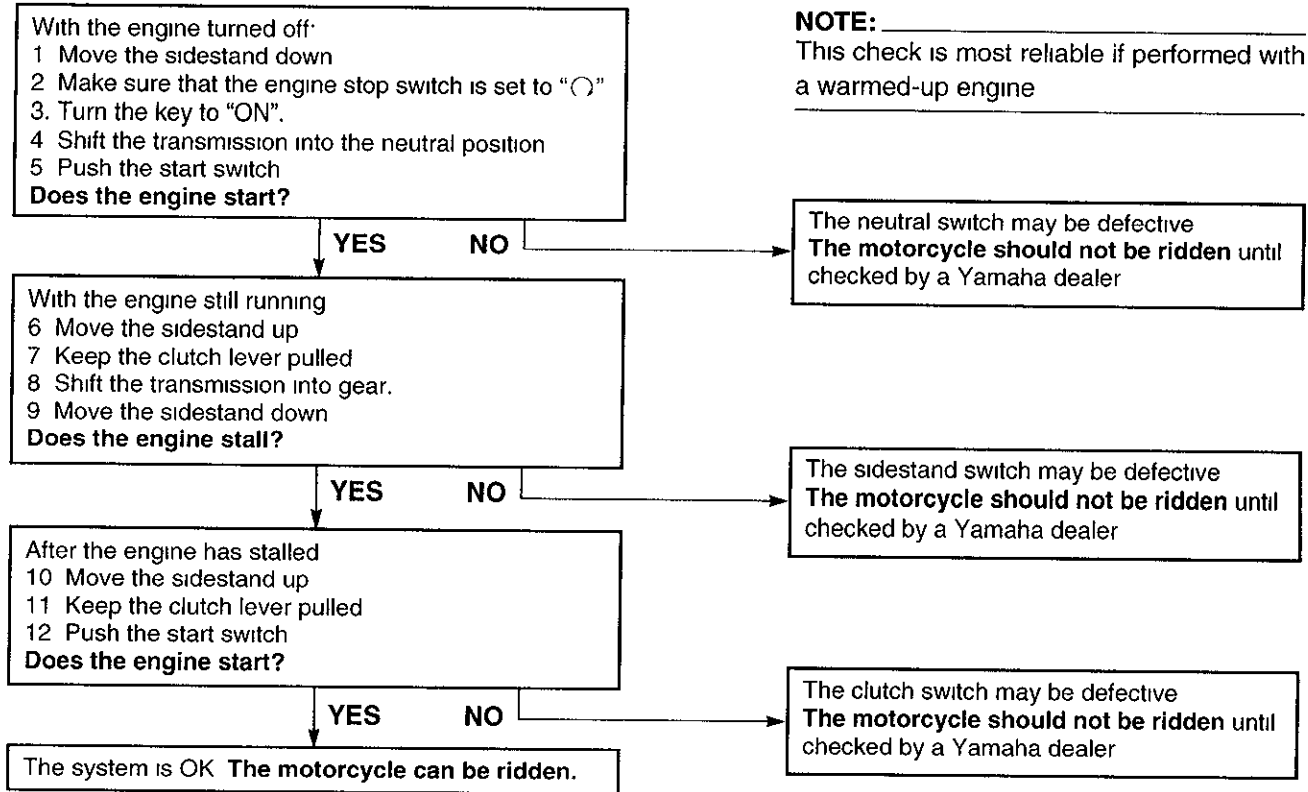

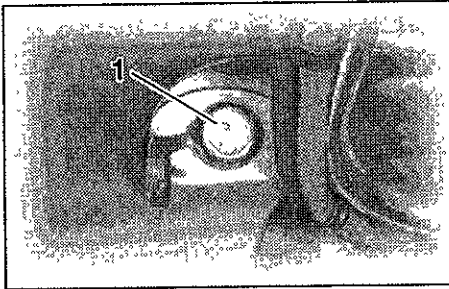

1 Auxiliary DC jack

EAU01788

Auxiliary DC jack and terminals

12-V accessories connected to the auxiliary DC jack at the front and auxiliary DC terminals under the rider seat can be used when the key is in the "ACC" or "ON" position

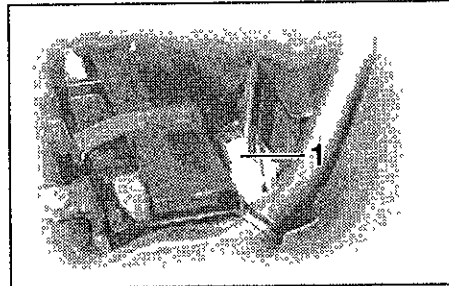

1. Auxiliary DC terminal

ECA00044

CAUTION:

The accessories connected to the auxiliary DC jack and terminals should not be used with the engine turned off, and their combined load must never exceed 5 A or 60 W, otherwise the battery may discharge.

EWA00017

⚠ WARNING

To prevent electrical shock or short-circuiting, make sure that the caps are installed when the auxiliary DC jack and terminals are not being used.

Location of parts	4-1
Headsets (optional)	4-2
Control unit	4-3
Making basic settings	4-4
Making mode settings	4-5
Cassette deck operation	4-8
Radio operation	4-12
Optional CD changer operation	4-16
Auxiliary audio source operation	4-17

Location of parts

4

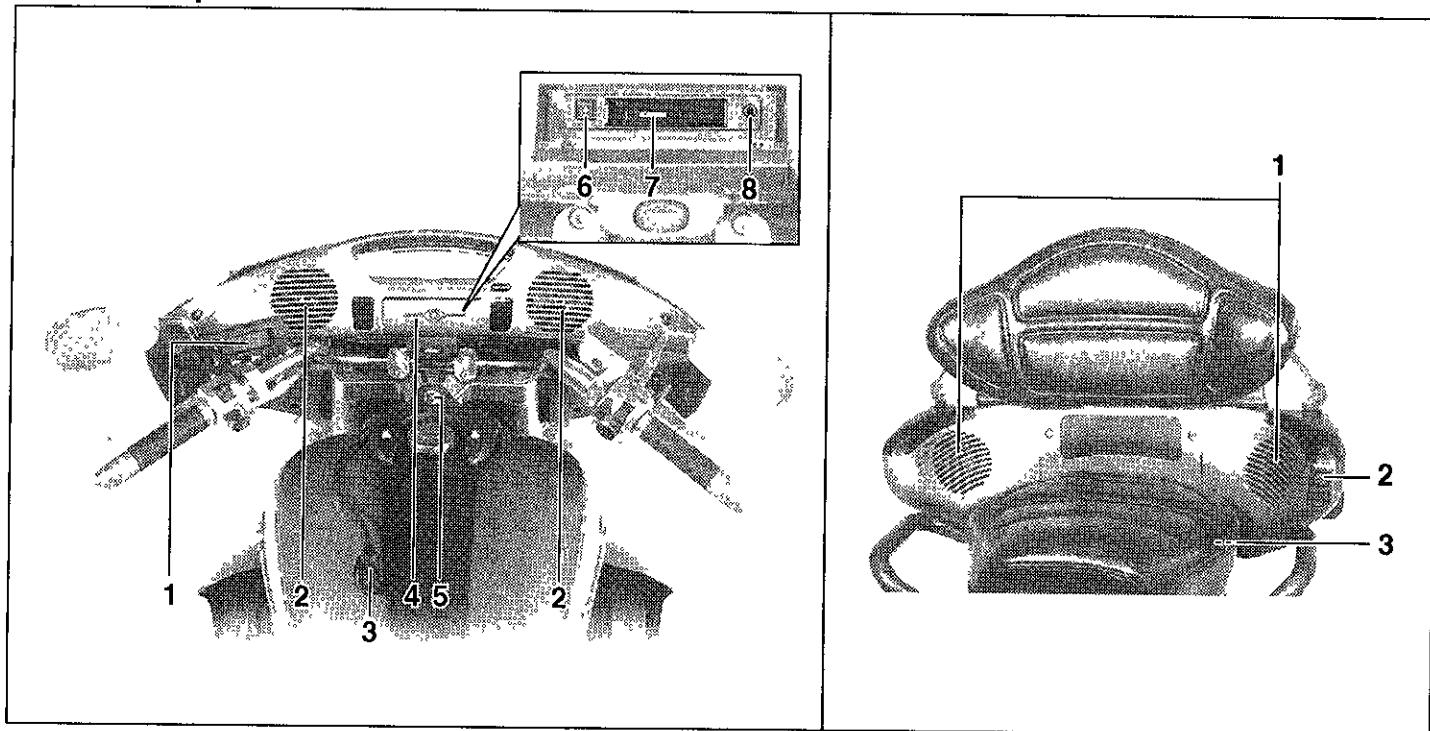

- 1 Audio system control unit
- 2 Front speaker (× 2)
- 3 Rider headset jack
- 4 Cassette deck lid

- 5 Main switch/steering lock
- 6 Eject ("▲") button
- 7 Cassette deck compartment
- 8 Auxiliary audio input jack

- 1 Rear speaker (× 2)
- 2 Passenger volume control knob
- 3 Passenger headset jack

⚠ WARNING

- It is dangerous to operate the audio system controls while riding. Never take your hands off the handlebars while riding.
- Keep the volume at a low enough level to be aware of traffic conditions and ensure safety.

CAUTION

- Do not use the audio system for a long period of time when the engine is not running as the battery may discharge.
- The control unit, cassette deck and speakers are water-resistant; however, it is good practice to cover them with a plastic bag when washing the motorcycle.
- When cleaning the control unit display, use a neutral detergent. Never use strong abrasive cleaning products, fuel (gasoline), thinner, etc.

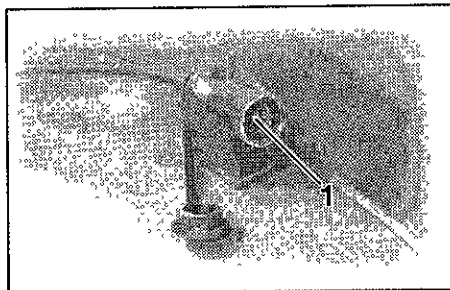

1 Rider headset jack

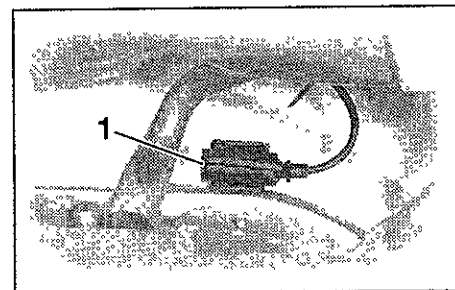

1. Passenger headset jack

Headsets (optional)

For intercom use, two headsets are necessary. Consult a Yamaha dealer if you wish to obtain headsets.

Connect the headsets to the jacks shown in the illustrations and make sure that the headsets are selected as the output. (See the "Selecting the output" section on page 4-5 for further instructions.)

AUDIO SYSTEM

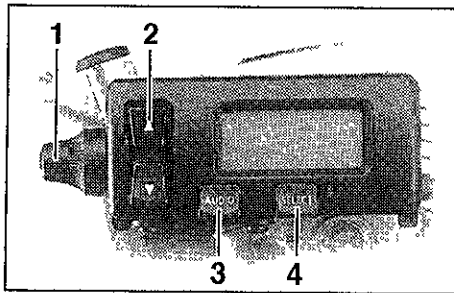

4

- 1 Volume control knob
- 2 Up/down ("◊") switch
- 3 Audio system button "AUDIO"
- 4 Selection button "SELECT"

Control unit

Volume control knob

This knob adjusts the audio system volume

Up/down ("◊") switch

This switch is used to perform the following operations

Short push (less than one second)

- Skipping songs on the cassette tape
- Selecting a preset radio station
- Selecting a track on the optional CD changer
- Tuning in a radio station manually
- Adjusting the intercom volume
- Changing the settings in a mode

Long push (one second or more)

- Changing the cassette deck play direction
- Tuning in a radio station automatically
- Selecting a CD in the optional CD changer

Audio system button "AUDIO"

This button is used to perform the following operations

Short push (less than one second)

- Turning on the audio system
- Changing the audio source in the following sequence

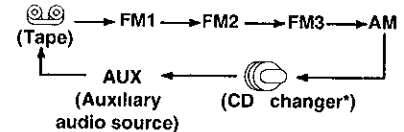

* The CD mode appears in the display only when the optional CD changer is installed

Long push (one second or more)

- Turning off the audio system

Selection button “SELECT”

This button is used to perform the following operations.

Short push (less than two seconds)

- Changing modes in the following sequence

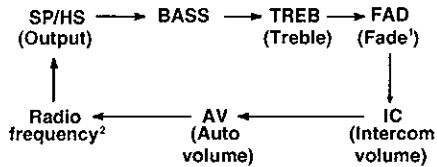

¹ This mode does not appear in the display when the headsets are selected as the output

² This mode appears in the display only when one of the radio frequency bands is selected as the audio source

- Programming preset radio stations

Long push (two seconds or more)

- Selecting the preset radio station programming mode

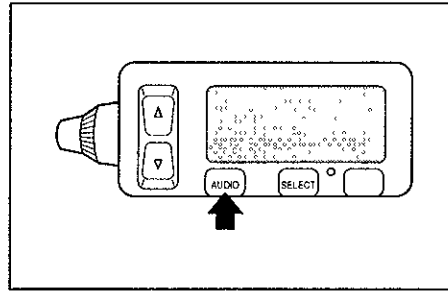

Making basic settings

Turning on/off the audio system

To turn the power on

1. Make sure that the key is in the “ACC” or “ON” position.
2. Push the “AUDIO” button once for less than one second

To turn the power off

Push the “AUDIO” button once for one second or more.

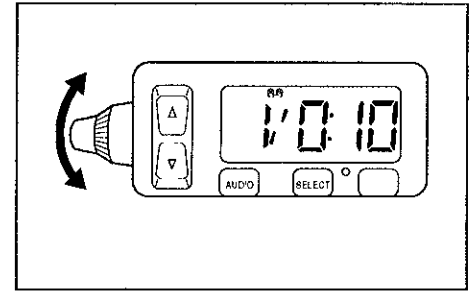

Adjusting the audio system volume

Turn the volume control knob until the desired audio system volume is displayed (e.g., “Vo:10”). The audio system volume can be set between “0” and “30”. After the adjustment is made, the audio system returns to normal operation and the current audio mode appears in the display.

AUDIO SYSTEM

Making mode settings

General procedure

The following setting procedure applies to the audio system and optional CD changer.

NOTE:

In order to make settings in any of the audio system modes, make sure that the audio system is selected. If necessary, push the "AUDIO" button for less than one second

1. Push the "AUDIO" button for less than one second.
2. Repeatedly push the "SELECT" button for less than one second until the desired mode appears in the display. With each press of the button, the mode changes in the following sequence

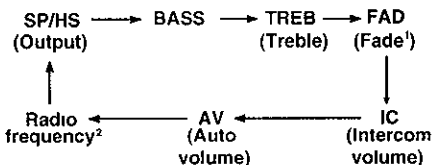

¹ This mode does not appear in the display when the headsets are selected as the output

² This mode appears in the display only when one of the radio frequency bands is selected as the audio source

3. While the selected mode is displayed (for about five seconds), repeatedly push either side of the up/down switch for less than one second until the desired setting is displayed

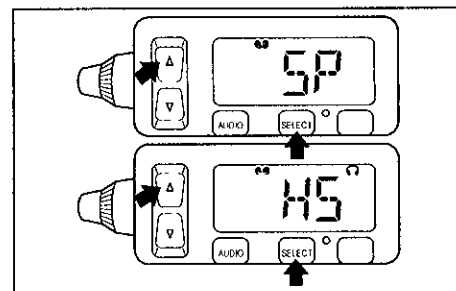

Selecting the output (speakers or headsets)

1. Repeatedly push the "SELECT" button for less than one second until either "SP" (speakers) or "HS" and "🎧" (headsets) appear in the display
2. Push either side of the up/down switch for less than one second to change the setting.

NOTE:

The speakers and headsets cannot be used at the same time.

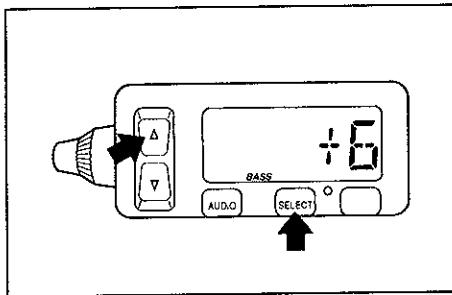

Adjusting the bass level

1. Repeatedly push the "SELECT" button for less than one second until "BASS" appears at the bottom of the display.
2. Repeatedly push either side of the up/down switch for less than one second until the desired level is displayed. The bass level can be set between "-6" and "+6".

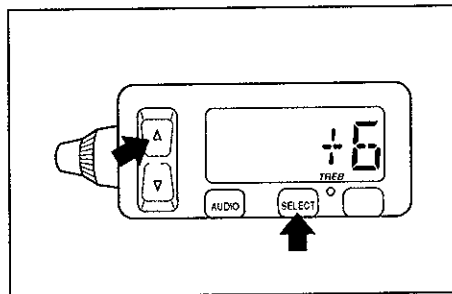

Adjusting the treble level

1. Repeatedly push the "SELECT" button for less than one second until "TREB" appears at the bottom of the display.
2. Repeatedly push either side of the up/down switch for less than one second until the desired level is displayed. The treble level can be set between "-6" and "+6".

AUDIO SYSTEM

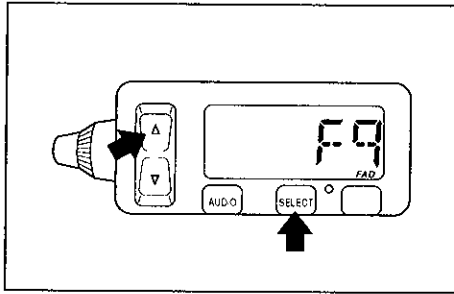

set between "F9" (front speakers only) and "R9" (rear speakers only)

NOTE: _____
When the fade level is set to "0", the front and rear speaker levels are the same.

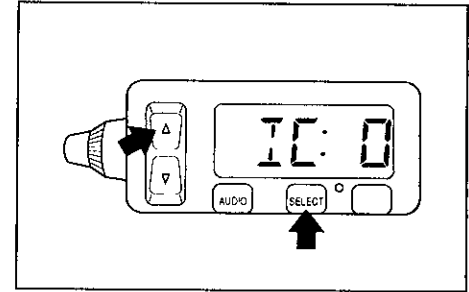

4

Adjusting the fade level (balance between front and rear speakers)

1. Make sure that the speakers are selected as the output source. (See the "Selecting the output" section on page 4-5 for selection procedures)
2. Repeatedly push the "SELECT" button for less than one second until "FAD" appears at the bottom of the display.
3. Repeatedly push either side of the up/down switch for less than one second until the desired level is displayed. The fade level can be

Adjusting the intercom volume

1. Repeatedly push the "SELECT" button for less than one second until the intercom volume (e.g., "IC:10") appears in the display.
2. Repeatedly push either side of the up/down switch for less than one second until the desired volume is displayed. The intercom volume can be set between "0" and "20"

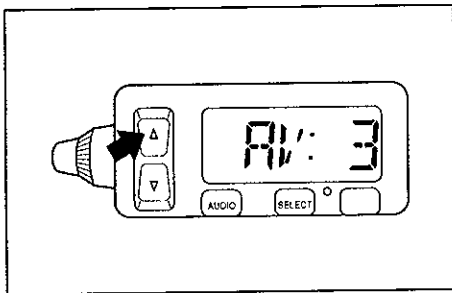

Adjusting the auto volume

When riding the motorcycle, external noise may override the audio system output volume. The audio system features an automatic volume control function which compensates for external noise.

1. Repeatedly push the "SELECT" button for less than one second until the auto volume (e.g., "AV: 3") appears in the display.
2. Repeatedly push either side of the up/down switch for less than one second until the desired volume is displayed. The auto volume can be set between "0" and "5".

Intercom operation

Provided both the rider and passenger are wearing headsets, they can talk to each other through the intercom at any time. (See the "Adjusting the intercom volume" section on page 4-7 for adjustment procedures.)

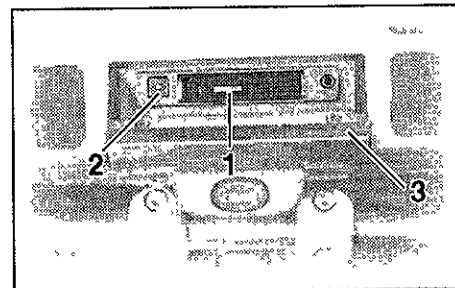

1. Cassette deck compartment
2. Eject ("▲") button
3. Cassette deck lid

Cassette deck operation

⚠ WARNING

- It is dangerous to operate the cassette deck while riding. Never take your hands off the handlebars while riding.
- Keep the volume at a low enough level to be aware of traffic conditions and ensure safety.

AUDIO SYSTEM

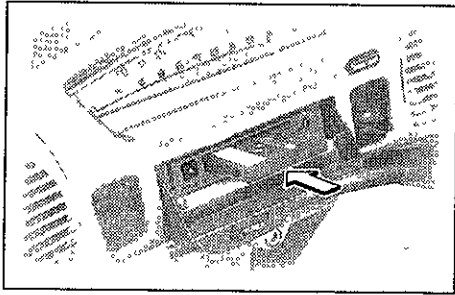

- To clean the tape head, use a de-magnetizing cleaning cassette, but be sure to turn the volume all the way down to avoid speaker damage.

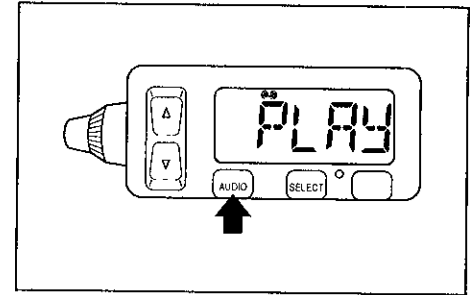

4

CAUTION:

- Keep the cassette deck lid closed at all times, except when inserting or removing a cassette.
- Do not leave cassette tapes in direct sunlight for a long period of time.
- Do not allow the inside of the cassette deck to get wet. If this happens, keep the cassette deck lid open and dry out the deck in the shade.

Playing a cassette tape

- 1 Make sure that the audio system is turned on. (See page 4-3.)
- 2 Insert a cassette tape into the cassette compartment as shown. "LOAD", then "PLAY" appears in the display. (If a cassette is already inserted, push the "AUDIO" button until "PLAY" appears in the display.) The tape starts playing

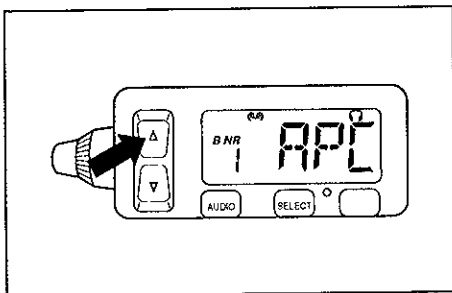

- NOTE:**
- The maximum number of songs that can be skipped in either direction is 9.
 - To stop skipping songs, push the up/down switch in the opposite direction that songs are being skipped.

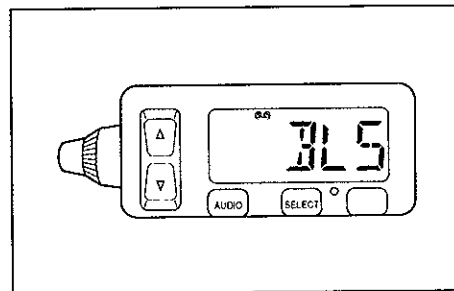

Skipping songs

While a cassette tape is playing, push either side of the up/down switch once for less than one second for each song to be skipped. Pushing "▽" skips songs in the forward direction. Pushing "△" skips songs in the reverse direction. "APC" (auto program control) and the number of songs to be skipped (e.g., "3") appear in the display. When skipping songs in reverse, a minus sign appears in front of the number of songs to be skipped (e.g., "-2"). ("−1" indicates that the current song will be played again.)

Skipping a blank

When there is a long blank portion of tape on the cassette, "BLS" appears in the display and the cassette deck automatically fast-forwards the tape to the next song.

AUDIO SYSTEM

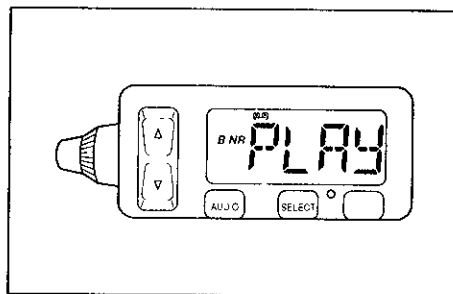
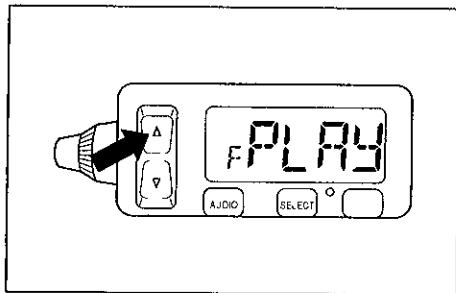

4

Changing the tape play direction

While the cassette tape is playing, push either side of the up/down switch for more than one second to reverse the play direction. "F" appears in the display when the tape is played in the forward direction. "R" appears in the display when the tape is played in the reverse direction.

Turning on/off the Dolby noise reduction system

While the cassette tape is playing, push the eject ("▲") button for more than two seconds to turn the Dolby B noise reduction system on or off. "B NR" appears in the display when the noise reduction system is turned on.

NOTE:

- The Dolby noise reduction system has been manufactured under license from Dolby Laboratories Licensing Corporation.
- Dolby and the double "D" symbol are registered trademarks of Dolby Laboratories Licensing Corporation.

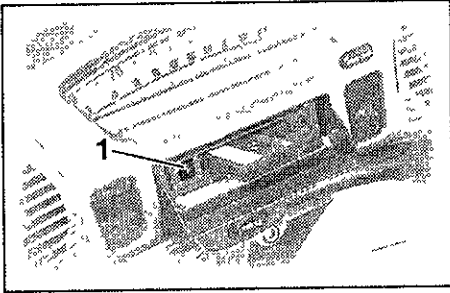

1 Eject ("▲") button

Ejecting the cassette tape

Push the eject ("▲") button to eject the tape from the cassette deck. "EJCT" appears in the display, and then "CASS" starts flashing.

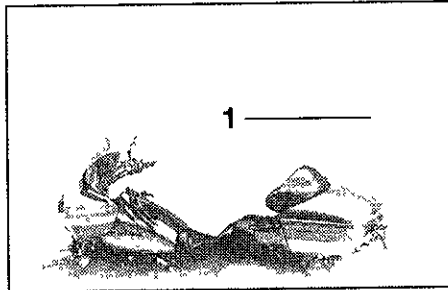

1 Radio antenna

Radio operation

⚠ WARNING

- It is dangerous to operate the radio while riding. Never take your hands off the handlebars while riding.
- Keep the volume at a low enough level to be aware of traffic conditions and ensure safety.
- Never ride the motorcycle with the radio antenna folded down.

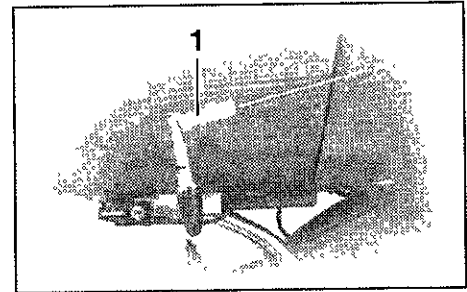

1 Sleeve

NOTE:

- Lift the sleeve to fold the antenna down
- Be sure to lower the sleeve fully after putting the antenna back to the original position.

AUDIO SYSTEM

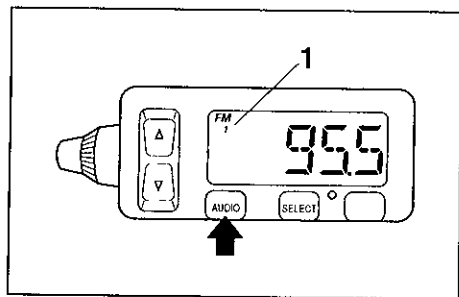

1 Frequency band

4

Selecting a frequency band

This radio offers three FM bands and one AM band. Since all three FM bands cover the whole FM frequency range, any one of them can be selected for tuning in an FM station. These three FM bands are useful for categorizing FM preset stations. Repeatedly push the "AUDIO" button for less than one second until the desired frequency band appears in the display.

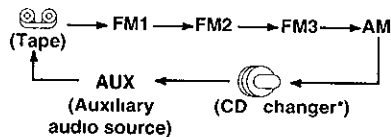

* The CD mode appears in the display only when the optional CD changer is installed

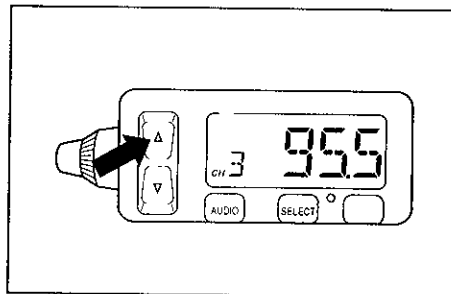

Tuning in a radio station automatically

1. Select a frequency band (See page 4-13)
2. Push either side of the up/down switch once for one second or more. The radio automatically tunes in the first station that has a strong enough signal to be received.

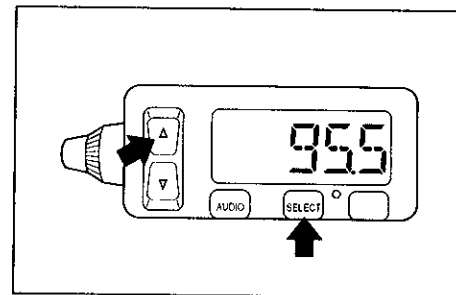

Tuning in a radio station manually

In order to tune in a particular radio station (e.g., when the signal is too weak for automatic tuning), the radio frequency can be selected manually as follows:

1. Select a frequency band. (See page 4-13.)
2. Repeatedly push the "SELECT" button for less than one second until the currently selected radio frequency appears in the display.

3. Push either side of the up/down switch for less than one second until the desired frequency is displayed. The frequency changes in 0.2-MHz steps for FM and in 10-kHz steps for AM.

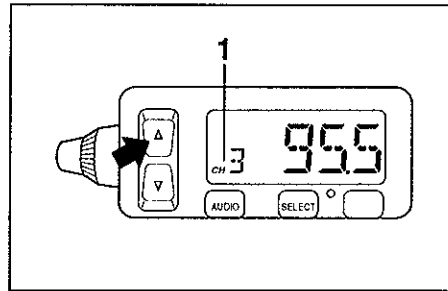

1 Preset station number

Tuning in a preset radio station

1. Select a frequency band (See page 4-13)
2. Repeatedly push either side of the up/down switch for less than one second until the desired preset station number is displayed

NOTE:

To be able to tune in a preset radio station, you must have previously programmed at least one. (See the following sections.)

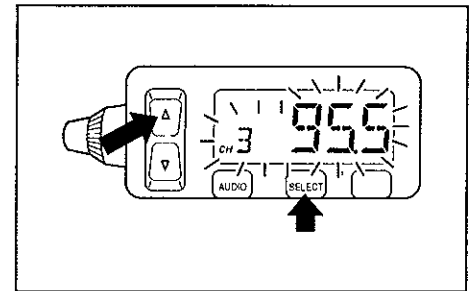

Programming preset radio stations manually

Up to six stations can be programmed for each frequency band (FM1, FM2, FM3, and AM) using either manual or automatic tuning

Using manual tuning

1. Manually tune in a radio station that you wish to preset (See page 4-15.)
2. Push the "SELECT" button once for two seconds or more. The radio frequency and preset station number "1" (to the right of "CH") start flashing.

AUDIO SYSTEM

- 3 Repeatedly push either side of the up/down switch for less than one second until the desired preset number ("1" through "6") is displayed.

NOTE: _____

Selecting "A" will automatically program the preset stations. See the following section

4

4. Push the "SELECT" button once for less than one second to store the radio station selected in step 1 under the preset number selected in step 3.
- 5 Repeat this procedure to preset other radio stations

Using automatic tuning

- 1 Select a frequency band. (See page 4-13)
2. Push the "SELECT" button once for two seconds or more. The radio frequency and preset station number "1" (to the right of "CH.") start flashing
3. Push either side of the up/down switch once for one second or more to tune in a station automatically
- 4 Repeatedly push either side of the up/down switch for less than one second until the desired preset number ("1" through "6") is displayed.
- 5 Push the "SELECT" button once for less than one second to store the radio station selected in step 3 under the preset number selected in step 4
- 6 Repeat this procedure to preset other radio stations

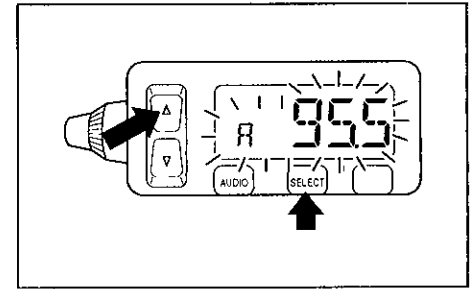

Programing preset radio stations automatically

Up to six stations can be programmed automatically for each frequency band (FM1, FM2, FM3, and AM) as follows

NOTE: _____

This function works best in areas with strong radio signals.

1. Select a frequency band. (See page 4-13.)
- 2 Push the "SELECT" button once for two seconds or more. The radio frequency and preset station number "1" (to the right of "CH.") start flashing

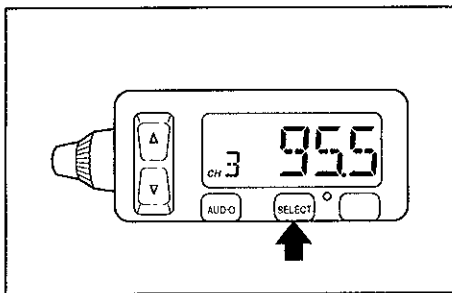

3. Repeatedly push either side of the up/down switch for less than one second until "A" (automatic) appears in the display.
4. Push the "SELECT" button once for less than one second to program preset radio stations automatically

Optional CD changer operation

! WARNING

- It is dangerous to operate the CD changer while riding. Never take your hands off the handlebars while riding.
- Keep the volume at a low enough level to be aware of traffic conditions and ensure safety.

An optional six-disc CD changer can be mounted in the travel trunk. Ask a Yamaha dealer to install the genuine Clarion CDC635 model

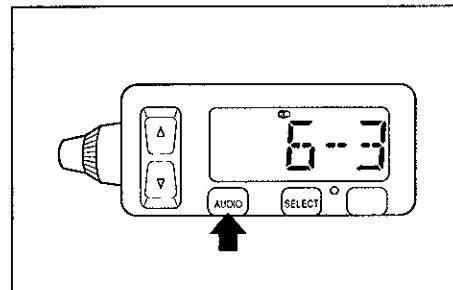

Playing a CD

1. Insert up to six CDs into the CD changer. Follow the manufacturer's directions.
2. Push the "AUDIO" button until "Ⓢ" as well as the CD number and track number (e.g., "6-3") appear in the display. The CD starts playing.

NOTE:

"6-3" indicates track no 3 on CD no 6.

AUDIO SYSTEM

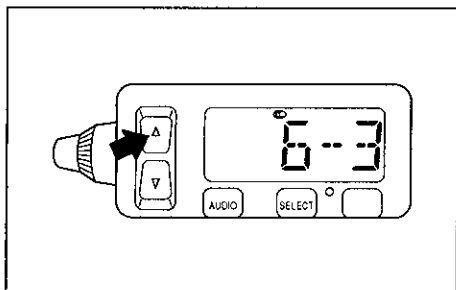

4

Selecting a CD

Repeatedly push either side of the up/down switch for one second or more until the number for the desired CD appears in the display.

Selecting a CD track

Repeatedly push either side of the up/down switch for less than one second until the number for the desired CD track appears in the display.

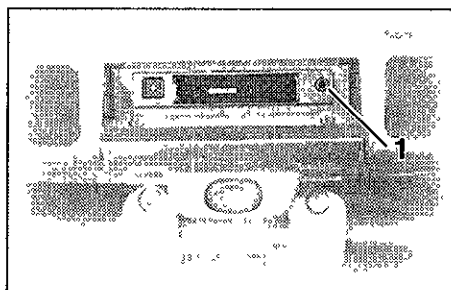

1 Auxiliary audio input jack

Auxiliary audio source operation

Auxiliary audio equipment can be connected to, and played through, the audio system

1. Insert the output plug of the auxiliary equipment into the jack located at the right of the cassette deck

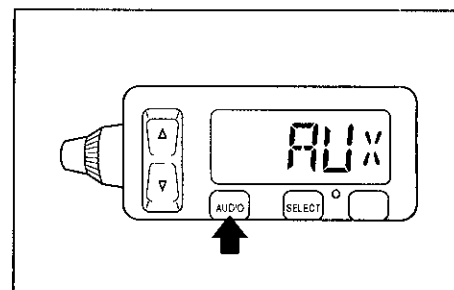

2. Repeatedly push the "AUDIO" button for less than one second until "AUX" appears in the display. The auxiliary equipment can now be played through the audio system.

PRE-OPERATION CHECKS

Pre-operation check list 5-1

PRE-OPERATION CHECKS

The condition of a vehicle is the owner's responsibility. Vital components can start to deteriorate quickly and unexpectedly, even if the vehicle remains unused (for example, as a result of exposure to the elements). Any damage, fluid leakage or loss of tire air pressure could have serious consequences. Therefore, it is very important, in addition to a thorough visual inspection, to check the following points before each ride.

Pre-operation check list

ITEM	CHECKS	PAGE
Fuel	<ul style="list-style-type: none">• Check fuel level in fuel tank• Refuel if necessary• Check fuel line for leakage	3-11
Engine oil	<ul style="list-style-type: none">• Check oil level in engine• If necessary, add recommended oil to specified level• Check vehicle for oil leakage	7-12
Final gear oil	<ul style="list-style-type: none">• Check vehicle for oil leakage	7-15
Coolant	<ul style="list-style-type: none">• Check coolant level in reservoir• If necessary, add recommended coolant to specified level• Check cooling system for leakage	7-15-7-16
Front brake	<ul style="list-style-type: none">• Check operation• If soft or spongy, have Yamaha dealer bleed hydraulic system• Check lever free play• Adjust if necessary• Check fluid level in reservoir• If necessary, add recommended brake fluid to specified level• Check hydraulic system for leakage	7-24, 7-26-7-29
Rear brake	<ul style="list-style-type: none">• Check operation• If soft or spongy, have Yamaha dealer bleed hydraulic system• Check fluid level in reservoir• If necessary, add recommended brake fluid to specified level• Check hydraulic system for leakage	7-25-7-29

PRE-OPERATION CHECKS

ITEM	CHECKS	PAGE
Clutch	<ul style="list-style-type: none"> • Check operation • If soft or spongy, have Yamaha dealer bleed hydraulic system • Check fluid level in reservoir • If necessary, add recommended fluid to specified level • Check hydraulic system for leakage 	7-24, 7-27-7-29
Throttle grip	<ul style="list-style-type: none"> • Make sure that operation is smooth • Check cable free play • If necessary, have Yamaha dealer adjust cable free play and lubricate cable and grip housing 	7-19
Control cables	<ul style="list-style-type: none"> • Make sure that operation is smooth • Lubricate if necessary 	7-28
Wheels and tires	<ul style="list-style-type: none"> • Check for damage • Check tire condition and tread depth • Check air pressure • Correct if necessary 	7-20-7-23
Brake and shift pedals	<ul style="list-style-type: none"> • Make sure that operation is smooth • Lubricate pedal pivoting points if necessary 	7-29
Brake and clutch levers	<ul style="list-style-type: none"> • Make sure that operation is smooth • Lubricate lever pivoting points if necessary 	7-29
Sidestand	<ul style="list-style-type: none"> • Make sure that operation is smooth • Lubricate pivot if necessary 	7-30
Chassis fasteners	<ul style="list-style-type: none"> • Make sure that all nuts, bolts and screws are properly tightened • Tighten if necessary 	—
Instruments, lights, signals and switches	<ul style="list-style-type: none"> • Check operation • Correct if necessary 	—
Sidestand switch	<ul style="list-style-type: none"> • Check operation of ignition circuit cut-off system • If system is defective, have Yamaha dealer check vehicle 	3-19-3-20

PRE-OPERATION CHECKS

NOTE:

Pre-operation checks should be made each time the motorcycle is used. Such an inspection can be accomplished in a very short time; and the added safety it assures is more than worth the time involved

LWA00033

 **WARNING**

If any item in the Pre-operation check list is not working properly, have it inspected and repaired before operating the motorcycle.

OPERATION AND IMPORTANT RIDING POINTS

Starting and warming up a cold engine	6-1
Starting a warm engine	6-3
Shifting	6-3
Tips for reducing fuel consumption	6-4
Engine break-in	6-5
Parking	6-6

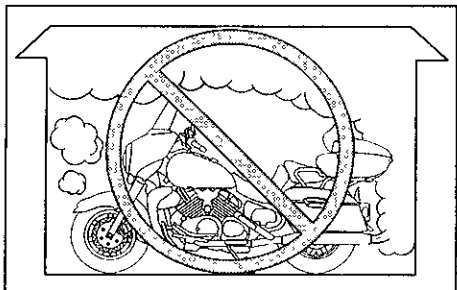

EAU00373

⚠ WARNING

- Become thoroughly familiar with all operating controls and their functions before riding. Consult a Yamaha dealer regarding any control or function that you do not thoroughly understand.
- Never start the engine or operate it in a closed area for any length of time. Exhaust fumes are poisonous, and inhaling them can cause loss of consciousness and death within a short time. Always make sure that there is adequate ventilation.

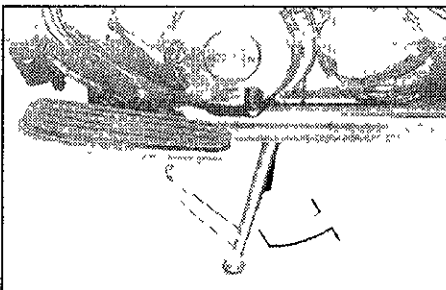

- Before starting out, make sure that the sidestand is up. If the sidestand is not raised completely, it could contact the ground and distract the operator, resulting in a possible loss of control.

Starting and warming up a cold engine

EAU01843

In order for the ignition circuit cut-off system to enable starting, one of the following conditions must be met:

- The transmission is in the neutral position.
- The transmission is in gear with the clutch lever pulled and the sidestand up

EW000054

⚠ WARNING

- Before starting the engine, check the function of the ignition circuit cut-off system according to the procedure described on page 3-21.
- Never ride with the sidestand down.

OPERATION AND IMPORTANT RIDING POINTS

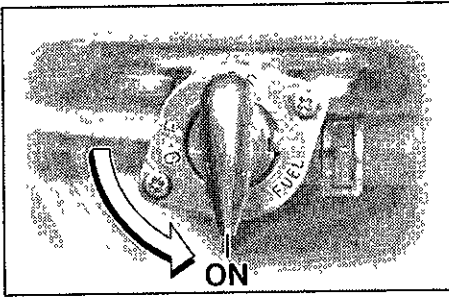

1. Turn the fuel cock lever to "ON".
2. Turn the key to "ON" and make sure that the engine stop switch is set to "O".

EC000035

CAUTION:

If the fuel level warning light comes on, check the fuel level, and, if necessary, refuel as soon as possible.

3. Shift the transmission into the neutral position.

NOTE:

When the transmission is in the neutral position, the neutral indicator light should be on, otherwise have a Yamaha dealer check the electrical circuit.

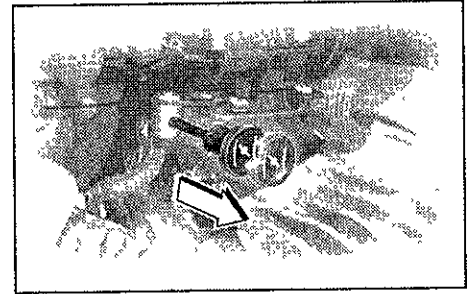

4. Turn the starter (choke) on and completely close the throttle. (See page 3-13 for starter (choke) operation.)
5. Start the engine by pushing the start switch

NOTE:

If the engine fails to start, release the start switch, wait a few seconds, and then try again. Each starting attempt should be as short as possible to preserve the battery. Do not crank the engine more than 10 seconds on any one attempt.

OPERATION AND IMPORTANT RIDING POINTS

ECA00031

CAUTION:

The engine trouble warning light should come on when the start switch is pushed, and it should go off when the start switch is released. If the engine trouble warning does not come on when pushing the start switch, or it remains on after starting, have a Yamaha dealer check the self-diagnosis device.

- 6 After starting the engine, move the starter (choke) knob back halfway

ECA00045

CAUTION:

For maximum engine life, never accelerate hard when the engine is cold!

- 7 When the engine is warm, turn the starter (choke) off

NOTE:

The engine is warm when it responds normally to the throttle with the starter (choke) turned off

EAU01258

Starting a warm engine

Follow the same procedure as for starting a cold engine with the exception that the starter (choke) is not required when the engine is warm

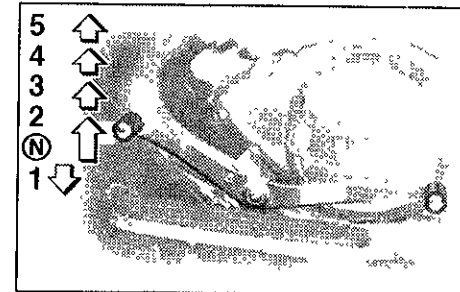

EAU00423

Shifting

Shifting gears lets you control the amount of engine power available for starting off, accelerating, climbing hills, etc

The gear positions are shown in the illustration

NOTE:

To shift the transmission into the neutral position, press the shift pedal down repeatedly until it reaches the end of its travel, and then slightly raise it.

EC000048

EAU04577

CAUTION:

- Even with the transmission in the neutral position, do not coast for long periods of time with the engine off, and do not tow the motorcycle for long distances. The transmission is properly lubricated only when the engine is running. Inadequate lubrication may damage the transmission.
- Always use the clutch while changing gears to avoid damaging the engine, transmission, and drive train, which are not designed to withstand the shock of forced shifting.

Tips for reducing fuel consumption

Fuel consumption depends largely on your riding style. Consider the following tips to reduce fuel consumption

- Turn the starter (choke) off as soon as possible
- Shift up swiftly, and avoid high engine speeds during acceleration.
- Do not rev the engine while shifting down, and avoid high engine speeds with no load on the engine.
- Turn the engine off instead of letting it idle for an extended length of time (e.g., in traffic jams, at traffic lights or at railroad crossings)

OPERATION AND IMPORTANT RIDING POINTS

EAU01128

Engine break-in

There is never a more important period in the life of your engine than the period between 0 and 1,600 km. For this reason, you should read the following material carefully.

Since the engine is brand new, do not put an excessive load on it for the first 1,600 km. The various parts in the engine wear and polish themselves to the correct operating clearances. During this period, prolonged full-throttle operation or any condition that might result in engine overheating must be avoided.

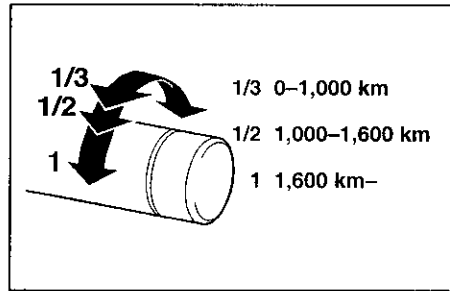

EAU01171*

0–1,000 km

Avoid prolonged operation above 1/3 throttle.

1,000–1,600 km

Avoid prolonged operation above 1/2 throttle.

EC000056*

CAUTION:

After 1,000 km of operation, the engine oil and final gear oil must be changed, and the oil filter cartridge replaced.

1,600 km and beyond

The vehicle can now be operated normally.

EC000049

CAUTION:

If any engine trouble should occur during the engine break-in period, immediately have a Yamaha dealer check the vehicle.

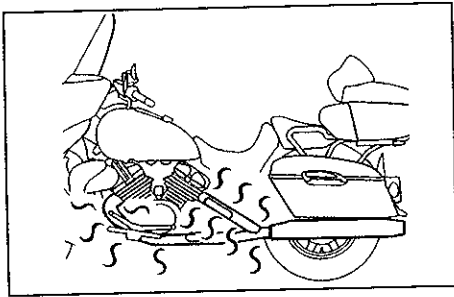

EAU00457

Parking

When parking, stop the engine, remove the key from the main switch, and then turn the fuel cock lever to "OFF".

EW000058

WARNING

- Since the engine and exhaust system can become very hot, park in a place where pedestrians or children are not likely to touch them.
- Do not park on a slope or on soft ground, otherwise the motorcycle may overturn.

PERIODIC MAINTENANCE AND MINOR REPAIR

Owner's tool kit	7-1	Checking and lubricating the cables	7-28
Periodic maintenance and lubrication chart	7-3	Checking and lubricating the throttle grip and cable	7-28
Removing and installing cowlings and panels ..	7-6	Checking and lubricating the brake and shift pedals	7-29
Checking the spark plugs	7-10	Checking and lubricating the brake and clutch levers	7-29
Engine oil and oil filter cartridge	7-12	Checking and lubricating the sidestand	7-30
Final gear oil	7-15	Checking the front fork	7-31
Coolant	7-15	Checking the steering	7-31
Cleaning the air filter elements	7-17	Checking the wheel bearings	7-32
Adjusting the carburetors ..	7-19	Battery	7-33
Adjusting the throttle cable free play	7-19	Replacing the fuses	7-34
Adjusting the valve clearance	7-20	Replacing the headlight bulb	7-36
Tires ..	7-20	Replacing a turn signal light bulb or the tail/brake light bulb	7-37
Cast wheels	7-23	Replacing the license plate light bulb	7-37
Clutch lever free play	7-24	Supporting the motorcycle	7-38
Adjusting the brake lever free play ..	7-24	Troubleshooting	7-39
Adjusting the brake pedal position ..	7-25	Troubleshooting charts	7-40
Adjusting the rear brake light switch ..	7-25		
Checking the front and rear brake pads	7-26		
Checking the brake and clutch fluid levels	7-27		
Changing the brake and clutch fluids	7-28		

PERIODIC MAINTENANCE AND MINOR REPAIR

EAU00462

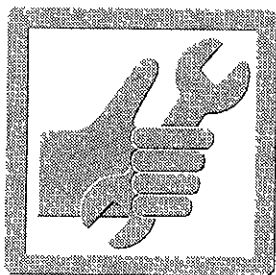

WARNING

If you are not familiar with motorcycle maintenance work, have a Yamaha dealer do it for you.

EW000060

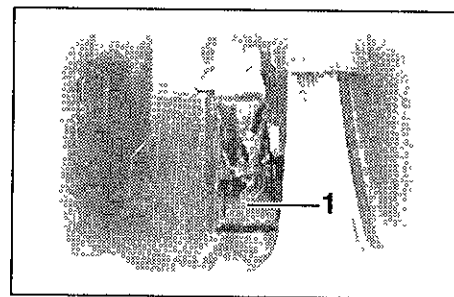

1 Owner's tool kit

EAU00464

Safety is an obligation of the owner. Periodic inspection, adjustment and lubrication will keep your vehicle in the safest and most efficient condition possible. The most important points of inspection, adjustment, and lubrication are explained on the following pages.

7

The intervals given in the periodic maintenance and lubrication chart should be simply considered as a general guide under normal riding conditions. However, **DEPENDING ON THE WEATHER, TERRAIN, GEOGRAPHICAL LOCATION, AND INDIVIDUAL USE, THE MAINTENANCE INTERVALS MAY NEED TO BE SHORTENED**

IAU03568

Owner's tool kit

The owner's tool kit is located inside the right side case. (See page 3-15 for side case opening procedures.)

The service information included in this manual and the tools provided in the owner's tool kit are intended to assist you in the performance of preventive maintenance and minor repairs. However, additional tools such as a torque wrench may be necessary to perform certain maintenance work correctly.

PERIODIC MAINTENANCE AND MINOR REPAIR

NOTE:

If you do not have the tools or experience required for a particular job, have a Yamaha dealer perform it for you.

EW000063

WARNING

Modifications not approved by Yamaha may cause loss of performance and render the vehicle unsafe for use. Consult a Yamaha dealer before attempting any changes.

PERIODIC MAINTENANCE AND MINOR REPAIR

EAU03685

Periodic maintenance and lubrication chart

NOTE:

- The annual checks must be performed every year, except if a kilometer-based maintenance is performed instead.
- From 50,000 km, repeat the maintenance intervals starting from 10,000 km.
- Items marked with an asterisk should be performed by a Yamaha dealer as they require special tools, data and technical skills.

NO	ITEM	CHECK OR MAINTENANCE JOB	ODOMETER READING (× 1,000 km)					ANNUAL CHECK
			1	10	20	30	40	
1	* Fuel line	• Check fuel hoses for cracks or damage		√	√	√	√	√
2	* Fuel filter	• Check condition			√		√	
3	Spark plugs	• Check condition		√		√		
		• Clean and regap			√			
		• Replace			√		√	
4	* Valves	• Check valve clearance • Adjust	Every 40,000 km					
5	Air filter element	• Clean		√		√		
		• Replace			√		√	
6	* Clutch	• Check operation, fluid level and vehicle for fluid leakage (See NOTE on page 7-5)	√	√	√	√	√	
7	* Front brake	• Check operation, fluid level and vehicle for fluid leakage (See NOTE on page 7-5)	√	√	√	√	√	√
		• Replace brake pads	Whenever worn to the limit					
8	* Rear brake	• Check operation, fluid level and vehicle for fluid leakage (See NOTE on page 7-5)	√	√	√	√	√	√
		• Replace brake pads	Whenever worn to the limit					
9	* Brake hoses	• Check for cracks or damage		√	√	√	√	√
		• Replace (See NOTE on page 7-5)	Every 4 years					

PERIODIC MAINTENANCE AND MINOR REPAIR

NO.	ITEM	CHECK OR MAINTENANCE JOB	ODOMETER READING (× 1,000 km)					ANNUAL CHECK
			1	10	20	30	40	
10	* Wheels	• Check runout and for damage		√	√	√	√	
11	* Tires	• Check tread depth and for damage • Replace if necessary • Check air pressure • Correct if necessary		√	√	√	√	√
12	* Wheel bearings	• Check bearing for looseness or damage		√	√	√	√	
13	* Swingarm	• Check operation and for excessive play • Lubricate with lithium-soap-based grease		√	√	√	√	
14	* Steering bearings	• Check bearing play and steering for roughness • Lubricate with lithium-soap-based grease	√	√	√	√	√	
15	* Chassis fasteners	• Make sure that all nuts, bolts and screws are properly tightened		√	√	√	√	√
16	Sidestand	• Check operation • Lubricate		√	√	√	√	√
17	* Sidestand switch	• Check operation	√	√	√	√	√	√
18	* Front fork	• Check operation and for oil leakage		√	√	√	√	
19	* Shock absorber assembly	• Check operation and shock absorber for oil leakage		√	√	√	√	
20	* Rear suspension relay arm and connecting arm pivoting points	• Check operation • Lubricate with lithium-soap-based grease		√	√	√	√	
21	* Carburetors	• Check starter (choke) operation • Adjust engine idling speed and synchronization	√	√	√	√	√	√
22	Engine oil	• Change • Check oil level and vehicle for oil leakage	√	√	√	√	√	√
23	Engine oil filter cartridge	• Replace	√		√		√	
24	* Cooling system	• Check coolant level and vehicle for coolant leakage • Change		√	√	√	√	√
			Every 3 years					

PERIODIC MAINTENANCE AND MINOR REPAIR

NO.	ITEM	CHECK OR MAINTENANCE JOB	ODOMETER READING (× 1,000 km)					ANNUAL CHECK
			1	10	20	30	40	
25	* Final gear oil	• Check oil level and vehicle for oil leakage	√	√		√		
		• Change	√		√		√	
26	* Front and rear brake switches	• Check operation	√	√	√	√	√	√
27	Moving parts and cables	• Lubricate		√	√	√	√	√
28	* Throttle grip housing and cable	• Check operation and free play • Adjust the throttle cable free play if necessary • Lubricate the throttle grip housing and cable		√	√	√	√	√
29	* Lights, signals and switches	• Check operation • Adjust headlight beam	√	√	√	√	√	√

E AU04408

NOTE:

- The air filter needs more frequent service if you are riding in unusually wet or dusty areas.
- Hydraulic brake and clutch service
 - Regularly check and, if necessary, correct the brake and clutch fluid levels.
 - Every two years replace the internal components of the brake master cylinders and calipers as well as clutch master and release cylinders, and change the brake and clutch fluids.
 - Replace the brake and clutch hoses every four years and if cracked or damaged.

PERIODIC MAINTENANCE AND MINOR REPAIR

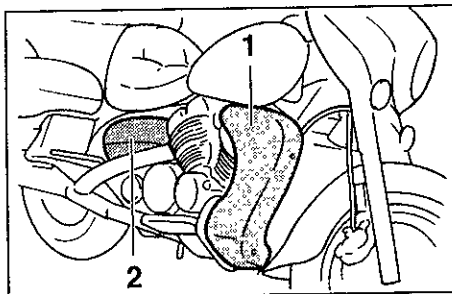

- 1 Cowling A
- 2 Panel A

EAU01139

Removing and installing cowlings and panels

The cowlings and panels shown above need to be removed to perform some of the maintenance jobs described in this chapter. Refer to this section each time a cowling or panel needs to be removed and installed.

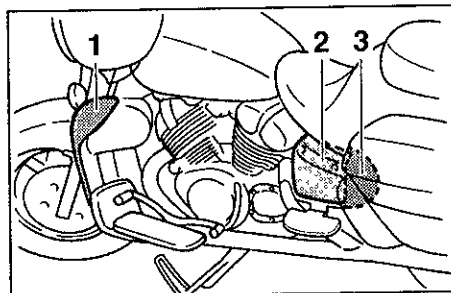

- 1 Cowling B
- 2 Panel B
- 3 Panel C

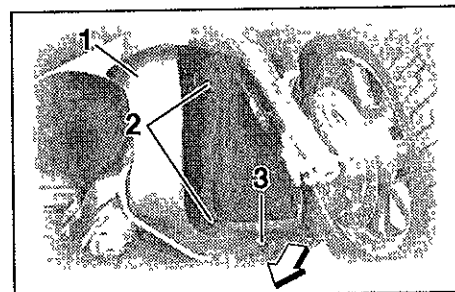

- 1 Cowling A
- 2 Screw (x 2)
- 3 Quick fastener

EAU04039

Cowling A

To remove the cowling

Remove the screws and the quick fastener, and then pull the cowling off as shown

NOTE:

The quick fastener is removed by pushing the center pin in with a screwdriver, then pulling the fastener out

PERIODIC MAINTENANCE AND MINOR REPAIR

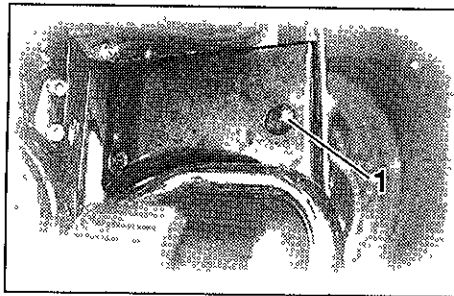

1 Screw

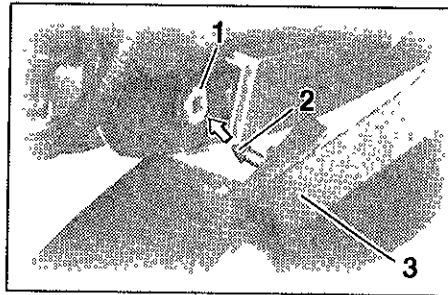

1 Grommet
2 Projection
3 Cowling A

To install the cowling

Place the cowling in the original position, and then install the screws and the quick fastener

NOTE:

- Make sure that the projection fits into the grommet
- To install the quick fastener, push the center pin out so that it will protrude from the fastener head, insert the fastener into the cowling, and then push the protruding pin in until it is flush with the fastener head

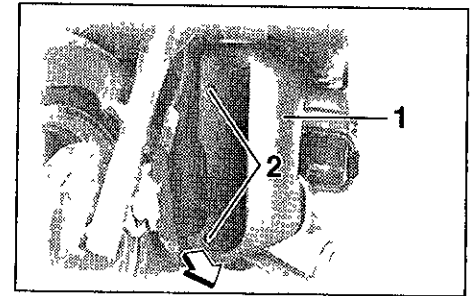

1 Cowling B
2 Screw (x 2)

Cowling B

To remove the cowling

- 1 Remove cowling A.
2. Remove the screws, and then pull the cowling off as shown.

EAU03634

PERIODIC MAINTENANCE AND MINOR REPAIR

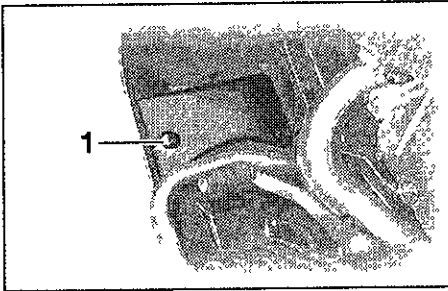

1 Screw

To install the cowling

- 1 Place the cowling in the original position, and then install the screws.

NOTE: _____

Make sure that the projection fits into the grommet.

- 2 Install cowling A.

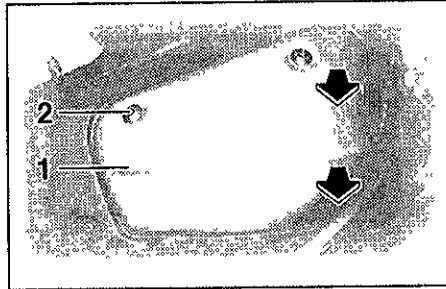

1 Panel A
2 Screw

Panel A

To remove the panel

Remove the screw, and then pull outward on the areas shown.

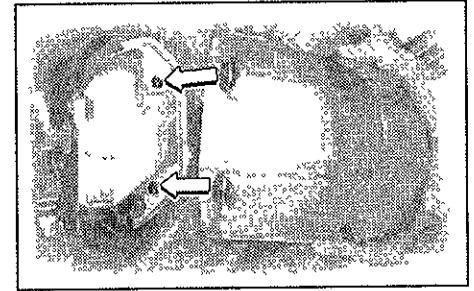

To install the panel

Place the panel in the original position, and then install the screw

EAU04807

PERIODIC MAINTENANCE AND MINOR REPAIR

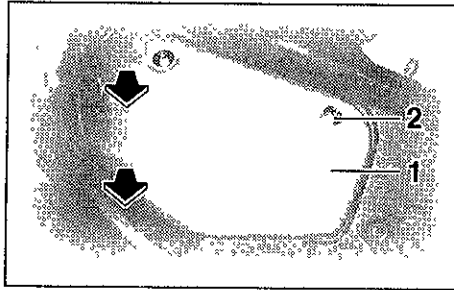

- 1 Panel B
- 2 Screw

Panel B

To remove the panel

Remove the screw, and then pull outward on the areas shown.

EAU04807

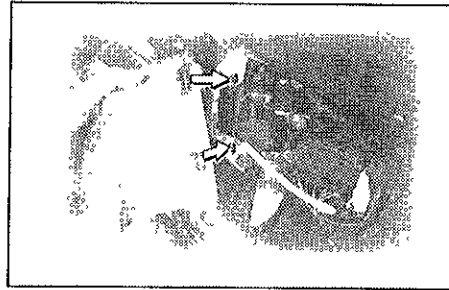

To install the panel

Place the panel in the original position, and then install the screw

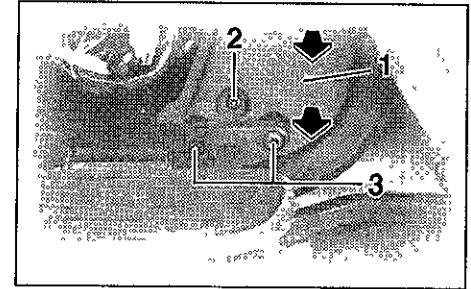

- 1 Panel C
- 2 Screw
- 3 Bolt (× 2)

Panel C

To remove the panel

- 1 Remove the left passenger footrest by removing the bolts
- 2 Remove the screw, and then pull the panel off as shown

EAU01785

PERIODIC MAINTENANCE AND MINOR REPAIR

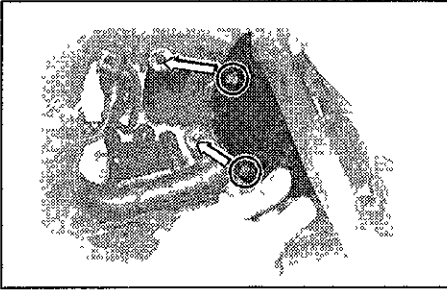

To install the panel

1. Place the panel in the original position, and then install the screw.
2. Install the passenger footrest by installing the bolts.

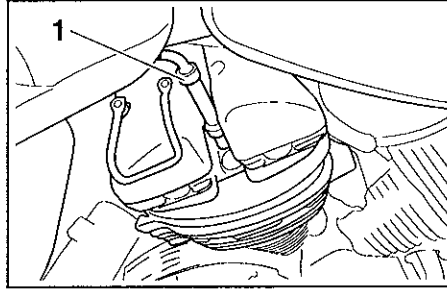

1 Spark plug cap

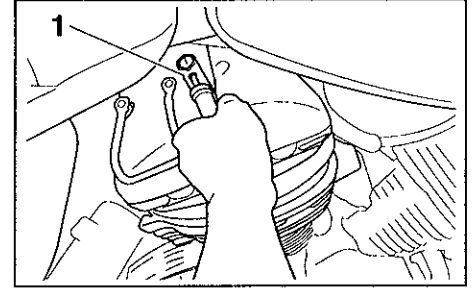

1 Spark plug wrench

Checking the spark plugs

EAU03329

The spark plugs are important engine components, which are easy to check. Since heat and deposits will cause any spark plug to slowly erode, the spark plugs should be removed and checked in accordance with the periodic maintenance and lubrication chart. In addition, the condition of the spark plugs can reveal the condition of the engine

To remove a spark plug

- 1 Remove the spark plug cap.

2. Remove the spark plug as shown, with the spark plug wrench included in the owner's tool kit

To check the spark plugs

1. Check that the porcelain insulator around the center electrode on each spark plug is a medium-to-light tan (the ideal color when the motorcycle is ridden normally).
- 2 Check that all spark plugs installed in the engine have the same color.

PERIODIC MAINTENANCE AND MINOR REPAIR

NOTE:

If any spark plug shows a distinctly different color, the engine could be defective. Do not attempt to diagnose such problems yourself. Instead, have a Yamaha dealer check the motorcycle.

3. Check each spark plug for electrode erosion and excessive carbon or other deposits, and replace it if necessary.

Specified spark plug
DPR8EA-9 (NGK) or
X24EPR-U9 (DENSO)

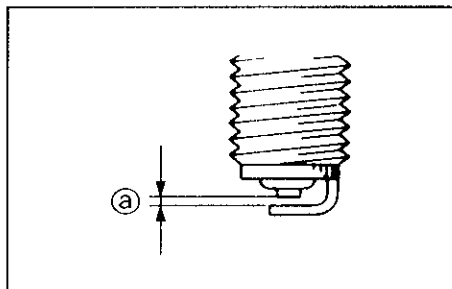

a Spark plug gap

To install a spark plug

1. Measure the spark plug gap with a wire thickness gauge and, if necessary, adjust the gap to specification.

Spark plug gap
0.8–0.9 mm

2. Clean the surface of the spark plug gasket and its mating surface, and then wipe off any grime from the spark plug threads.
3. Install the spark plug with the spark plug wrench, and then tighten it to the specified torque.

Tightening torque:

Spark plug
17.5 Nm (1.75 m·kgf)

NOTE:

If a torque wrench is not available when installing a spark plug, a good estimate of the correct torque is 1/4–1/2 turn past finger tight. However, the spark plug should be tightened to the specified torque as soon as possible.

4. Install the spark plug cap.

PERIODIC MAINTENANCE AND MINOR REPAIR

EAU04626

Engine oil and oil filter cartridge

The engine oil level should be checked before each ride. In addition, the oil must be changed and the oil filter cartridge replaced at the intervals specified in the periodic maintenance and lubrication chart

To check the engine oil level

1. Place the motorcycle on a level surface and hold it in an upright position

NOTE:

Make sure that the motorcycle is positioned straight up when checking the oil level. A slight tilt to the side can result in a false reading.

- 2 Start the engine, warm it up for several minutes, and then turn it off.

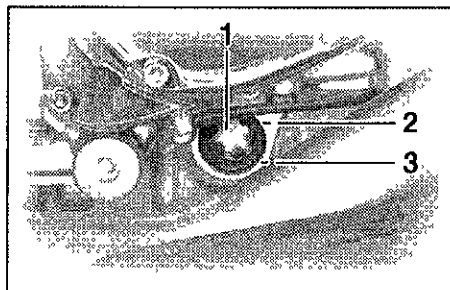

- 1 Engine oil level check window
- 2 Maximum level mark
- 3 Minimum level mark

- 3 Wait a few minutes until the oil settles, and then check the oil level through the check window located at the bottom-right side of the crankcase.

NOTE:

The engine oil should be between the minimum and maximum level marks.

4. If the engine oil is below the minimum level mark, add sufficient oil of the recommended type to raise it to the correct level.

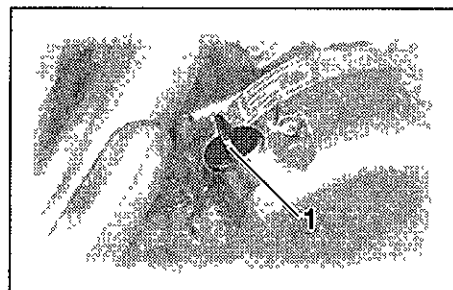

- 1 Engine oil filler cap

To change the engine oil (with or without oil filter cartridge replacement)

- 1 Start the engine, warm it up for several minutes, and then turn it off.
- 2 Place an oil pan under the engine to collect the used oil

PERIODIC MAINTENANCE AND MINOR REPAIR

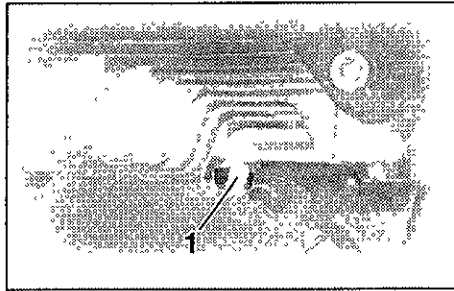

1 Engine oil drain bolt

3. Remove the engine oil filler cap and drain bolt to drain the oil from the crankcase

NOTE: _____
Skip steps 4–6 if the oil filter cartridge is not being replaced.

7

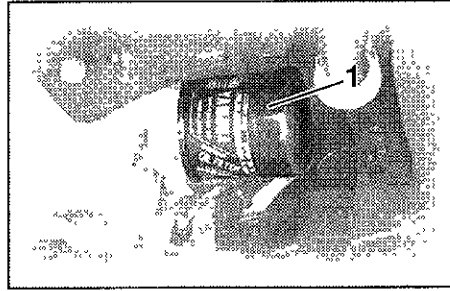

1 Engine oil filter cartridge

- 4 Remove the oil filter cartridge with an oil filter wrench.

NOTE: _____
An oil filter wrench is available at a Yamaha dealer

5. Apply a thin coat of engine oil to the O-ring of the new oil filter cartridge

NOTE: _____
Make sure that the O-ring is properly seated.

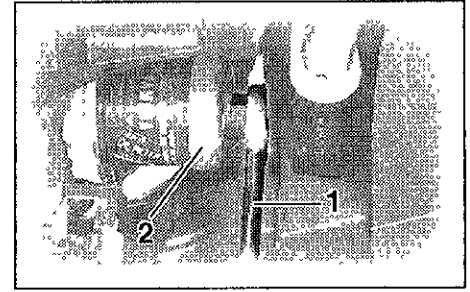

1 Torque wrench
2 Oil filter wrench

6. Install the new oil filter cartridge with an oil filter wrench, and then tighten it to the specified torque with a torque wrench.

Tightening torque:
Oil filter cartridge:
17 Nm (1.7 m·kgf)

7. Install the engine oil drain bolt, and then tighten it to the specified torque.

Tightening torque:
Engine oil drain bolt:
43 Nm (4.3 m·kgf)

PERIODIC MAINTENANCE AND MINOR REPAIR

ECA00133

EC000067

- 8 Add the specified amount of the recommended engine oil, and then install and tighten the oil filler cap

Recommended engine oil

See page 9-1

Oil quantity:

Without oil filter cartridge
replacement:

3.5 L

With oil filter cartridge
replacement:

3.7 L

Total amount (dry engine).

4.3 L

CAUTION:

- In order to prevent clutch slip-page (since the engine oil also lubricates the clutch), do not mix any chemical additives. Do not use oils with a diesel specification of "CD" or oils of a higher quality than specified. In addition, do not use oils labeled "ENERGY CONSERVING II" or higher.
- Make sure that no foreign material enters the crankcase.

9. Start the engine, and then let it idle for several minutes while checking it for oil leakage. If oil is leaking, immediately turn the engine off and check for the cause.

NOTE:

After the engine is started, the engine oil level warning light should go off if the oil level is sufficient.

CAUTION:

If the oil level warning light flickers or remains on, immediately turn the engine off and have a Yamaha dealer check the vehicle.

- 10 Turn the engine off, and then check the oil level and correct it if necessary.

PERIODIC MAINTENANCE AND MINOR REPAIR

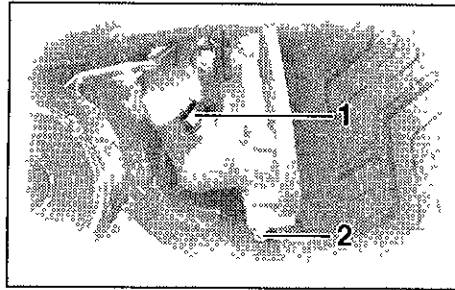

- 1 Final gear oil filler bolt
- 2 Final gear oil drain bolt

EAU01220

Final gear oil

The final gear case must be checked for oil leakage before each ride. If any leakage is found, have a Yamaha dealer check and repair the motorcycle. In addition, have a Yamaha dealer change the final gear oil at the intervals specified in the periodic maintenance and lubrication chart

7

Coolant

EAU01197

To check the coolant level

- 1 Place the motorcycle on a level surface and hold it in an upright position
2. Remove panel A (See page 7-8 for panel removal and installation procedures)

NOTE:

- The coolant level must be checked on a cold engine since the level varies with engine temperature.
- Make sure that the motorcycle is positioned straight up when checking the coolant level. A slight tilt to the side can result in a false reading.

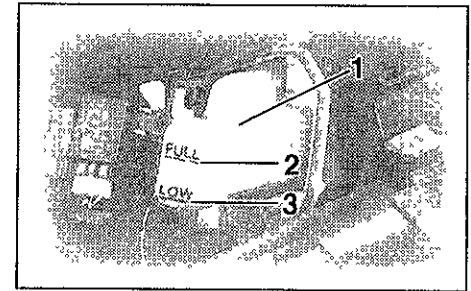

- 1 Coolant reservoir
- 2 Maximum level mark
- 3 Minimum level mark

- 3 Check the coolant level in the coolant reservoir

NOTE:

The coolant should be between the minimum and maximum level marks.

PERIODIC MAINTENANCE AND MINOR REPAIR

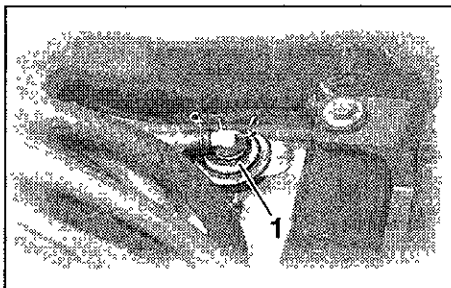

1 Coolant reservoir cap

4. If the coolant is at or below the minimum level mark, remove the rider seat (See page 3-13 for rider seat removal and installation procedures), open the reservoir cap, add coolant to the maximum level mark, and then close the reservoir cap and install the rider seat.

Coolant reservoir capacity:
0.84 L

EC000080

CAUTION:

- If coolant is not available, use distilled water or soft tap water instead. Do not use hard water or salt water since it is harmful to the engine.
- If water has been used instead of coolant, replace it with coolant as soon as possible, otherwise the engine may not be sufficiently cooled and the cooling system will not be protected against frost and corrosion.
- If water has been added to the coolant, have a Yamaha dealer check the antifreeze content of the coolant as soon as possible, otherwise the effectiveness of the coolant will be reduced.

NOTE:

The radiator fan is automatically switched on or off according to the coolant temperature in the radiator. If the engine overheats, see page 7-41 for further instructions.

EW000067

⚠ WARNING

Never attempt to remove the radiator cap when the engine is hot.

- 5 Install the panel.

PERIODIC MAINTENANCE AND MINOR REPAIR

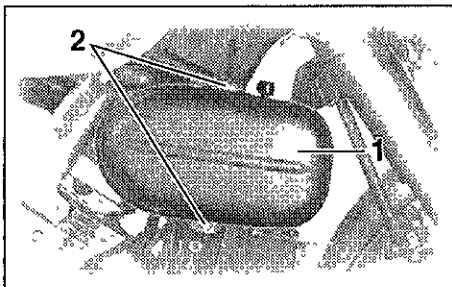

- 1 Air filter case
- 2 Bolt (x 2)

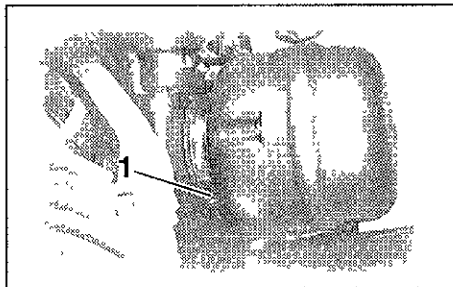

- 1 Air filter joint clamp screw

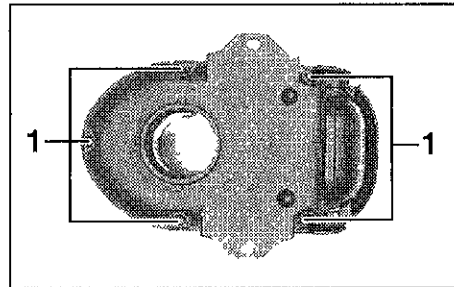

- 1 Air filter case bolt (x 5)

Cleaning the air filter elements

EAU03569

The air filter elements should be cleaned at the intervals specified in the periodic maintenance and lubrication chart. Clean the air filter elements more frequently if you are riding in unusually wet or dusty areas.

- 1 Remove cowlings A and B. (See pages 7-6 and 7-7 for cowlings removal and installation procedures.)

NOTE:

Continue as follows for each air filter element

- 2 Remove the air filter case by removing the bolts
- 3 Loosen the air filter joint clamp screw, and then pull the air filter off

- 4 Remove the air filter case cover by removing the bolts

PERIODIC MAINTENANCE AND MINOR REPAIR

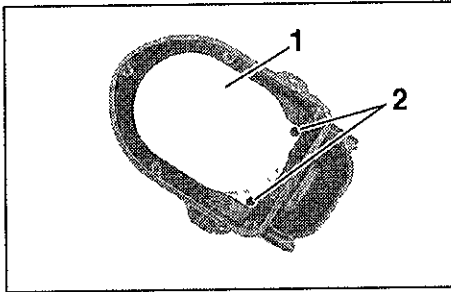

- 1 Air filter element
- 2 Air filter element screw (x 2)

5. Remove the air filter element by removing the screws.

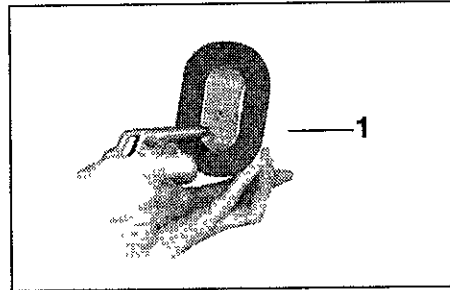

- 1 Air filter element

6. Lightly tap the air filter element to remove most of the dust and dirt, and then blow the remaining dirt out with compressed air as shown. If the air filter element is damaged, replace it.

7. Install the air filter element by fitting the projection on the air filter element into the holder in the air filter case, then tightening the screws.

EC000082*

CAUTION

- Make sure that the air filter element is properly seated in the air filter case.
- The engine should never be operated without the air filter element installed, otherwise the pistons and/or cylinders may become excessively worn.

PERIODIC MAINTENANCE AND MINOR REPAIR

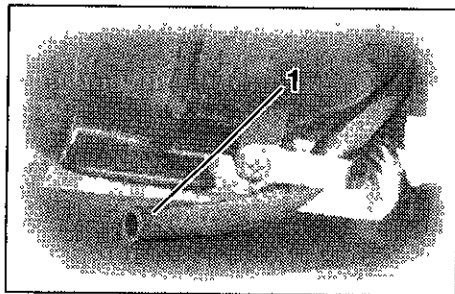

1 Air filter case drain hose

8. Install the air filter case cover by installing the bolts.
9. Install the air filter by pushing it onto the air filter joint, then tightening the air filter joint clamp screw.
10. Install the air filter case by installing the bolts.
11. Install the cowlings.

NOTE:

Make sure that the air filter case drain hose is routed as shown

EAU00630

Adjusting the carburetors

The carburetors are important parts of the engine and require very sophisticated adjustment. Therefore, most carburetor adjustments should be left to a Yamaha dealer, who has the necessary professional knowledge and experience. The adjustment described in the following section, however, may be serviced by the owner as part of routine maintenance.

CAUTION:

The carburetors have been set and extensively tested at the Yamaha factory. Changing these settings without sufficient technical knowledge may result in poor performance of or damage to the engine.

EC000095

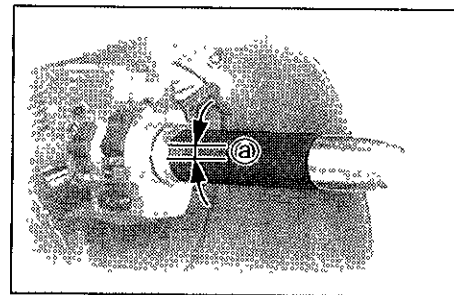

a Throttle cable free play

FAU00635

Adjusting the throttle cable free play

The throttle cable free play should measure 4–6 mm at the throttle grip. Periodically check the throttle cable free play and, if necessary, have a Yamaha dealer adjust it.

PERIODIC MAINTENANCE AND MINOR REPAIR

EAU00637

Adjusting the valve clearance

The valve clearance changes with use, resulting in improper air-fuel mixture and/or engine noise. To prevent this from occurring, the valve clearance must be adjusted by a Yamaha dealer at the intervals specified in the periodic maintenance and lubrication chart

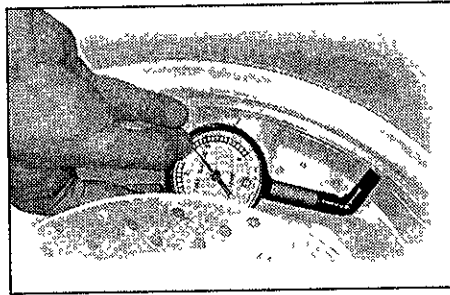

EAU03853

Tires

To maximize the performance, durability, and safe operation of your motorcycle, note the following points regarding the specified tires

Tire air pressure

The tire air pressure should be checked and, if necessary, adjusted before each ride

EWA00041

! WARNING

Tire inflation pressure should be checked and adjusted when the temperature of the tire equals the ambient air temperature. Tire inflation pressure must be adjusted according to total weight of cargo, rider, passenger, and accessories (cowling, side cases, etc.).

Tire air pressure (measured on cold tires)		
Load*	Front	Rear
Up to 90 kg	250 kPa (2 50 kgf/cm ² , 36 psi)	250 kPa (2 50 kgf/cm ² , 36 psi)
90 kg--maximum	250 kPa (2 50 kgf/cm ² , 36 psi)	280 kPa (2 80 kgf/cm ² , 41 psi)
Maximum load*	190 kg	

* Total weight of rider, passenger, cargo and accessories

7

PERIODIC MAINTENANCE AND MINOR REPAIR

EWA00042

⚠ WARNING

Proper loading of your motorcycle is important for several characteristics of your motorcycle, such as handling, braking, performance and safety. Do not carry loosely packed items that can shift. Securely pack your heaviest items close to the center of the motorcycle, and distribute the weight evenly from side to side. Properly adjust the suspension for your load, and check the condition and pressure of your tires. **NEVER OVERLOAD YOUR MOTORCYCLE.** Make sure the total weight of the cargo, rider, passenger, and accessories (cowling, side cases, etc. if approved for this model) does not exceed the maximum load of the motorcycle. Operation of an overloaded motorcycle could cause tire damage, an accident, or even injury.

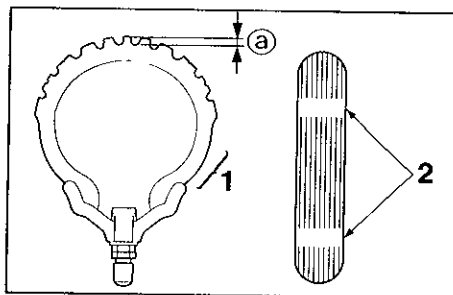

- 1 Tire sidewall
- 2 Tire wear indicator
- a Tire tread depth

Tire inspection

Always check the tires before operating the motorcycle. If a tire tread shows crosswise lines (minimum tread depth), if the tire has a nail or glass fragments in it, or if the side wall is cracked, contact a Yamaha dealer immediately and have the tire replaced.

EW000079

⚠ WARNING

- Have a Yamaha dealer replace excessively worn tires. Besides being illegal, operating the motorcycle with excessively worn tires decreases riding stability and can lead to loss of control.
- The replacement of all wheel- and brake-related parts, including the tires, should be left to a Yamaha dealer, who has the necessary professional knowledge and experience.

Minimum tire tread depth (front and rear)	1.0 mm
--	--------

NOTE:

These limits may be different by regulation from country to country. If so, conform to the limits specified by the regulations of your own country.

PERIODIC MAINTENANCE AND MINOR REPAIR

EW000132

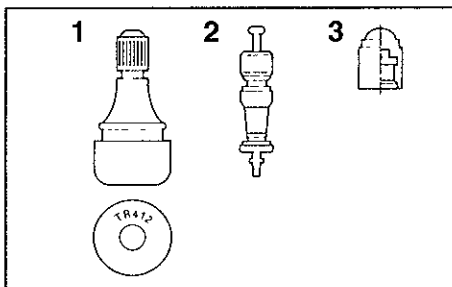

- 1 Tire air valve
- 2 Valve core
- 3 Valve cap with seal

Tire information

This motorcycle is equipped with tubeless tires, tire valves and cast wheels.

⚠ WARNING

- The front and rear tires should be of the same make and design, otherwise the handling characteristics of the motorcycle cannot be guaranteed.
- After extensive tests, only the tires listed below have been approved for this model by Yamaha Motor Co., Ltd.
- Always make sure that the valve caps are securely installed to prevent air pressure leakage.
- Use only the tire valves and valve cores listed below to avoid tire deflation during a ride.

FRONT

Manufacturer	Size	Model
Dunlop	150/80-16 71H	D404F
	150/80-16 M/C 71H	
Bridgestone	150/80-16 71H	G705
	150/80-16 M/C 71H	

Tire air valve	TR412
Valve core	#9000A

REAR

Manufacturer	Size	Model
Dunlop	150/90B 15 M/C 74H	D404
Bridgestone	150/90B 15 M/C 74H	G702

Tire air valve	PVR59A
Valve core	#9000

PERIODIC MAINTENANCE AND MINOR REPAIR

EAU00683

EAU03763

WARNING

- Have a Yamaha dealer replace excessively worn tires. Besides being illegal, operating the motorcycle with excessively worn tires decreases riding stability and can lead to loss of control.
- The replacement of all wheel- and brake-related parts, including the tires, should be left to a Yamaha dealer, who has the necessary professional knowledge and experience.

Cast wheels

To maximize the performance, durability, and safe operation of your motorcycle, note the following points regarding the specified wheels.

- The wheel rims should be checked for cracks, bends, warpage or damage before each ride. If any damage is found, have a Yamaha dealer replace the wheel. Do not attempt even the smallest repair to the wheel. A deformed or cracked wheel must be replaced.
- The wheel should be balanced whenever either the tire or wheel has been changed or replaced. An unbalanced wheel can result in poor performance, adverse handling characteristics, and a shortened tire life.
- Ride at moderate speeds after changing a tire since the tire surface must first be “broken in” for it to develop its optimal characteristics.

- After repairing or replacing the rear tire, tighten the valve stem nut and locknut to the specified torques

Tightening torques

Valve stem nut	1.6 Nm (0.16 m·kgf)
Valve stem locknut:	1.6 Nm (0.16 m·kgf)

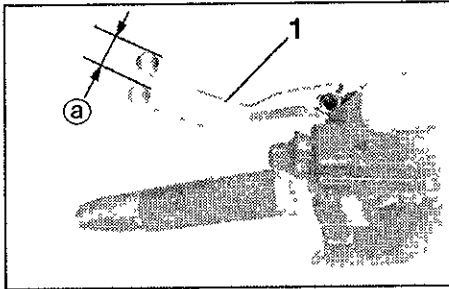

a Clutch lever free play

EAU00695

Clutch lever free play

Since this model is equipped with a hydraulic clutch, adjusting the clutch lever free play is not needed. However, it is necessary to check the clutch fluid level and check the hydraulic system for leakage before each ride. If the clutch lever free play does become excessive, and shifting becomes rough or clutch slippage occurs, causing poor acceleration, there may be air in the clutch system. If there is air in the hydraulic system, have a Yamaha dealer bleed the system before operating the motorcycle.

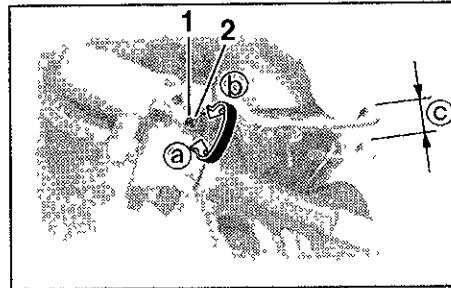

- 1 Locknut
- 2 Adjusting bolt
- c Brake lever free play

EAU00696

Adjusting the brake lever free play

The brake lever free play should measure 2–5 mm as shown. Periodically check the brake lever free play and, if necessary, adjust it as follows.

1. Loosen the locknut at the brake lever.
2. To increase the brake lever free play, turn the adjusting bolt in direction (a). To decrease the brake lever free play, turn the adjusting bolt in direction (b).

- 3 Tighten the locknut

EW000099

! WARNING

- After adjusting the brake lever free play, check the free play and make sure that the brake is working properly.
- A soft or spongy feeling in the brake lever can indicate the presence of air in the hydraulic system. If there is air in the hydraulic system, have a Yamaha dealer bleed the system before operating the motorcycle. Air in the hydraulic system will diminish the braking performance, which may result in loss of control and an accident.

PERIODIC MAINTENANCE AND MINOR REPAIR

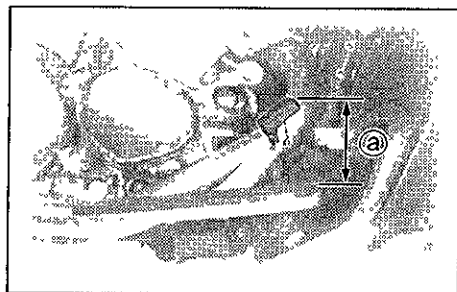

a Distance between brake pedal and footrest

Adjusting the brake pedal position

EAU01746

The top of the brake pedal should be positioned approximately 100 mm above the top of the footrest as shown. Periodically check the brake pedal position and, if necessary, have a Yamaha dealer adjust it.

E-W000109

⚠ WARNING

A soft or spongy feeling in the brake pedal can indicate the presence of air in the hydraulic system. If there is air in the hydraulic system, have a Yamaha dealer bleed the system before operating the motorcycle. Air in the hydraulic system will diminish the braking performance, which may result in loss of control and an accident.

EAU01799

Adjusting the rear brake light switch

The rear brake light switch, which is activated by the brake pedal, is properly adjusted when the brake light comes on just before braking takes effect. Since the brake light switch is a component of the cruise control system, it must be adjusted by a Yamaha dealer, who has the necessary professional knowledge and experience.

PERIODIC MAINTENANCE AND MINOR REPAIR

EAU00721

Checking the front and rear brake pads

The front and rear brake pads must be checked for wear at the intervals specified in the periodic maintenance and lubrication chart.

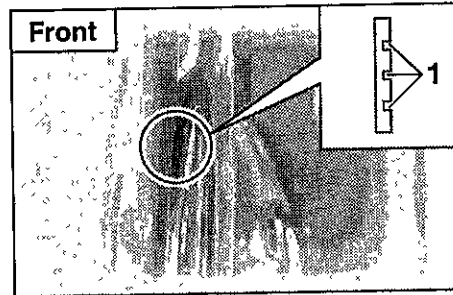

1 Wear indicator groove (× 3)

EAU03938

Front brake pads

Each front brake pad is provided with wear indicator grooves, which allow you to check the brake pad wear without having to disassemble the brake. To check the brake pad wear, check the wear indicator grooves. If a brake pad has worn to the point that the wear indicator grooves have almost disappeared, have a Yamaha dealer replace the brake pads as a set.

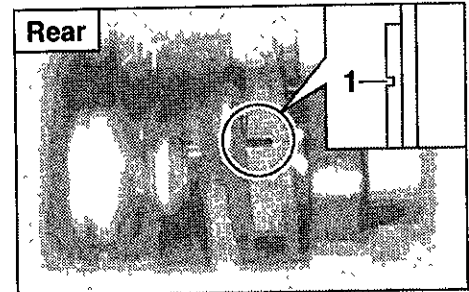

1 Wear indicator groove

EAU03939

Rear brake pads

Each rear brake pad is provided with a wear indicator groove, which allows you to check the brake pad wear without having to disassemble the brake. To check the brake pad wear, check the wear indicator groove. If a brake pad has worn to the point that the wear indicator groove has almost disappeared, have a Yamaha dealer replace the brake pads as a set.

PERIODIC MAINTENANCE AND MINOR REPAIR

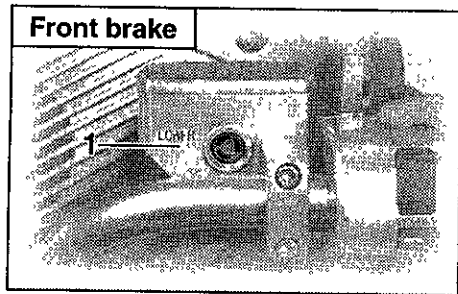

1 Minimum level mark

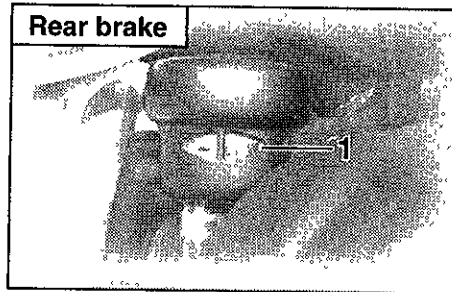

1 Minimum level mark

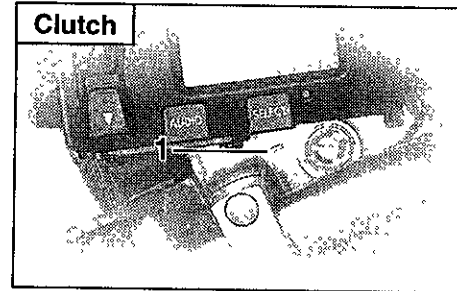

1 Minimum level mark

Checking the brake and clutch fluid levels

EAU03914

Insufficient brake or clutch fluid may allow air to enter the brake or clutch systems, possibly causing them to become ineffective.

Before riding, check that the brake and clutch fluids are above the minimum level marks and replenish if necessary. A low brake or clutch fluid level may indicate brake or clutch system leakage and/or worn brake pads. If the brake or clutch levels are low, be sure to check the brake or clutch systems for leakage and the brake pads for wear.

Observe these precautions:

- When checking the brake and clutch fluid levels, make sure that the top of each reservoir is level.
- Use only the recommended quality brake fluid, otherwise the rubber seals may deteriorate, causing leakage and poor braking or clutch performance.

Recommended brake and clutch fluid:

DOT 4 brake fluid

- Refill with the same type of brake fluid. Mixing fluids may result in a harmful chemical reaction and lead to poor braking or clutch performance.

- Be careful that water does not enter the brake or clutch fluid reservoir when refilling. Water will significantly lower the boiling point of the fluid and may result in vapor lock.
- Brake fluid may deteriorate painted surfaces or plastic parts. Always clean up spilled fluid immediately.
- As the brake pads wear, it is normal for the brake fluid level to gradually go down. However, if the brake fluid level goes down suddenly, have a Yamaha dealer check the cause.

PERIODIC MAINTENANCE AND MINOR REPAIR

Changing the brake and clutch fluids

EAU03984

Have a Yamaha dealer change the brake and clutch fluids at the intervals specified in the NOTE after the periodic maintenance and lubrication chart. In addition, have the oil seals of the brake and clutch master cylinders and calipers as well as the brake and clutch hoses replaced at the intervals listed below or whenever they are damaged or leaking.

- Oil seals: Replace every two years
- Brake and clutch hoses: Replace every four years.

Checking and lubricating the cables

EAU02962

The operation of all control cables and the condition of the cables should be checked before each ride, and the cables and cable ends should be lubricated if necessary. If a cable is damaged or does not move smoothly, have a Yamaha dealer check or replace it.

Recommended lubricant:
Engine oil

EW000112

WARNING

Damage to the outer sheath may interfere with proper cable operation and will cause the inner cable to rust. Replace a damaged cable as soon as possible to prevent unsafe conditions.

Checking and lubricating the throttle grip and cable

EAU04034

The operation of the throttle grip should be checked before each ride. In addition, the cable should be lubricated or replaced at the intervals specified in the periodic maintenance chart.

PERIODIC MAINTENANCE AND MINOR REPAIR

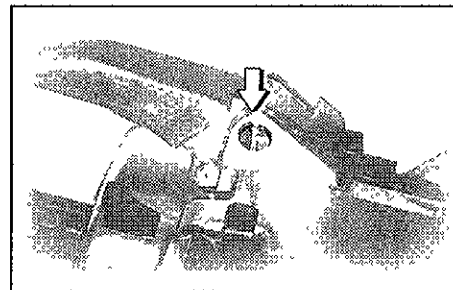
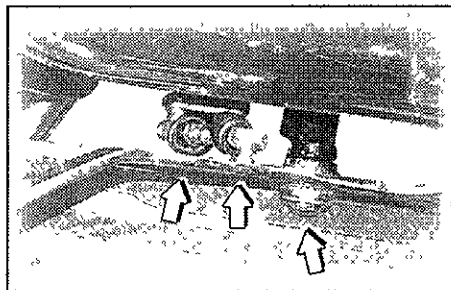
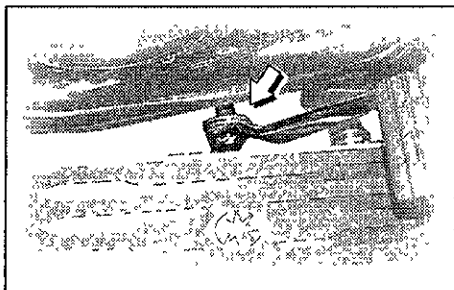

EAU03370

Checking and lubricating the brake and shift pedals

The operation of the brake and shift pedals should be checked before each ride, and the pedal pivots should be lubricated if necessary.

7

Recommended lubricant:
Lithium-soap-based grease
(all-purpose grease)

EAU03164

Checking and lubricating the brake and clutch levers

The operation of the brake and clutch levers should be checked before each ride, and the lever pivots should be lubricated if necessary.

Recommended lubricant:
Lithium-soap-based grease
(all-purpose grease)

PERIODIC MAINTENANCE AND MINOR REPAIR

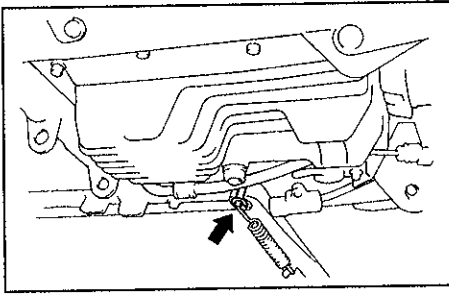

Recommended lubricant:
Lithium-soap-based grease
(all-purpose grease)

EAU03165

Checking and lubricating the sidestand

The operation of the sidestand should be checked before each ride, and the sidestand pivot and metal-to-metal contact surfaces should be lubricated if necessary.

EW000113

WARNING

If the sidestand does not move up and down smoothly, have a Yamaha dealer check or repair it.

PERIODIC MAINTENANCE AND MINOR REPAIR

Checking the front fork

EAU02939

The condition and operation of the front fork must be checked as follows at the intervals specified in the periodic maintenance and lubrication chart.

To check the condition

EW000115

⚠ WARNING

Securely support the motorcycle so that there is no danger of it falling over.

Check the inner tubes for scratches, damage and excessive oil leakage.

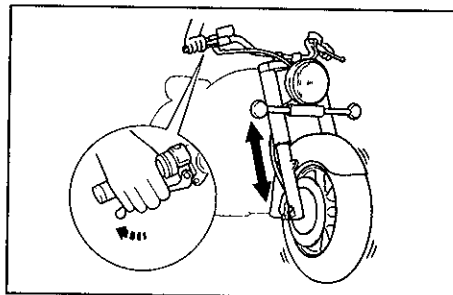

To check the operation

1. Place the motorcycle on a level surface and hold it in an upright position.
2. While applying the front brake, push down hard on the handlebars several times to check if the front fork compresses and rebounds smoothly

EC000098

CAUTION

If any damage is found or the front fork does not operate smoothly, have a Yamaha dealer check or repair it.

Checking the steering

EAU00794

Worn or loose steering bearings may cause danger. Therefore, the operation of the steering must be checked as follows at the intervals specified in the periodic maintenance and lubrication chart.

1. Place a stand under the engine to raise the front wheel off the ground.

EW000115

⚠ WARNING

Securely support the motorcycle so that there is no danger of it falling over.

PERIODIC MAINTENANCE AND MINOR REPAIR

EAU01144

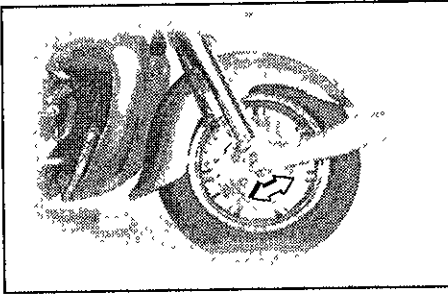

Checking the wheel bearings

The front and rear wheel bearings must be checked at the intervals specified in the periodic maintenance and lubrication chart. If there is play in the wheel hub or if the wheel does not turn smoothly, have a Yamaha dealer check the wheel bearings.

2. Hold the lower ends of the front fork legs and try to move them forward and backward. If any free play can be felt, have a Yamaha dealer check or repair the steering

PERIODIC MAINTENANCE AND MINOR REPAIR

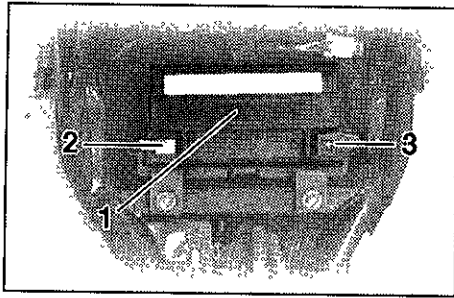

- 1 Battery
- 2 Negative terminal
- 3 Positive terminal

EAU00800

Battery

This motorcycle is equipped with a sealed-type (MF) battery, which does not require any maintenance. There is no need to check the electrolyte or to add distilled water.

EC000101

CAUTION:

Never attempt to remove the battery cell seals, as this would permanently damage the battery.

EW000116

WARNING

- **Electrolyte is poisonous and dangerous since it contains sulfuric acid, which causes severe burns. Avoid any contact with skin, eyes or clothing and always shield your eyes when working near batteries. In case of contact, administer the following FIRST AID.**
 - **EXTERNAL:** Flush with plenty of water.
 - **INTERNAL:** Drink large quantities of water or milk and immediately call a physician.
 - **EYES:** Flush with water for 15 minutes and seek prompt medical attention.
- **Batteries produce explosive hydrogen gas. Therefore, keep sparks, flames, cigarettes, etc., away from the battery and provide sufficient ventilation when charging it in an enclosed space.**
- **KEEP THIS AND ALL BATTERIES OUT OF THE REACH OF CHILDREN.**

To charge the battery

Have a Yamaha dealer charge the battery as soon as possible if it seems to have discharged. Keep in mind that the battery tends to discharge more quickly if the motorcycle is equipped with optional electrical accessories.

To store the battery

1. If the motorcycle will not be used for more than one month, remove the battery, fully charge it, and then place it in a cool, dry place.
2. If the battery will be stored for more than two months, check it at least once a month and fully charge it if necessary.
3. Fully charge the battery before installation.
4. After installation, make sure that the battery leads are properly connected to the battery terminals.

PERIODIC MAINTENANCE AND MINOR REPAIR

EC000102

CAUTION:

- Always keep the battery charged. Storing a discharged battery can cause permanent battery damage.
- To charge a sealed-type (MF) battery, a special (constant-voltage) battery charger is required. Using a conventional battery charger will damage the battery. If you do not have access to a sealed-type (MF) battery charger, have a Yamaha dealer charge your battery.

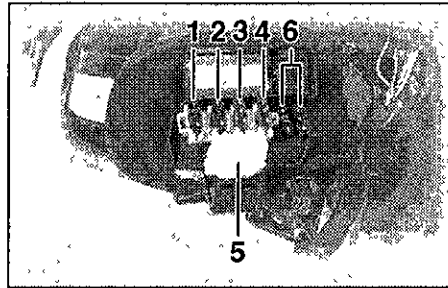

1. Cruise control fuse
2. Carburetor heater fuse
3. Auxiliary DC terminal fuse
4. Auxiliary DC jack fuse
5. Audio system fuse
6. Spare fuse (x 2)

EAU01801

Replacing the fuses

The main fuse box is located behind panel C. (See page 7-9 for panel removal and installation procedures.)

Fuse box 1 is located behind cowling A. (See page 7-6 for cowling removal and installation procedures)

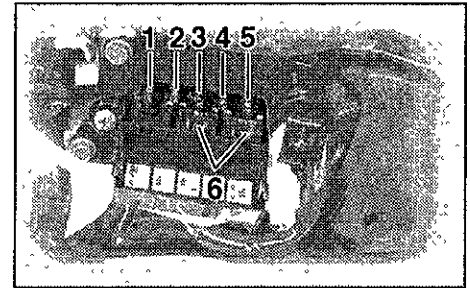

1. Odometer fuse
2. Radiator fan fuse
3. Headlight fuse
4. Signaling system fuse
5. Ignition fuse
6. Spare fuse (x 2)

Fuse box 2 is located behind panel B. (See page 7-9 for panel removal and installation procedures.)

PERIODIC MAINTENANCE AND MINOR REPAIR

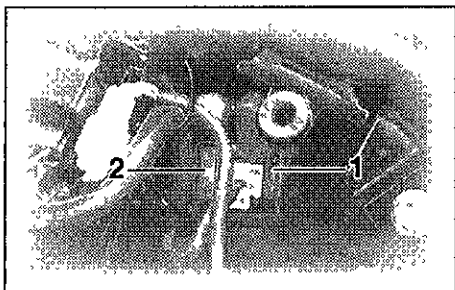

- 1 Main fuse
- 2 Spare main fuse

If a fuse is blown, replace it as follows.

1. Turn the key to "OFF" and turn off the electrical circuit in question.
2. Remove the blown fuse, and then install a new fuse of the specified amperage.

Specified fuses:

Fuse box 1

Cruise control fuse:	10 A
Carburetor heater fuse:	10 A
Auxiliary DC terminal fuse:	5 A
Auxiliary DC jack fuse:	5 A
Audio system fuse:	10 A

Fuse box 2

Ignition fuse:	10 A
Signaling system fuse:	15 A
Headlight fuse:	15 A
Radiator fan fuse:	10 A
Odometer fuse:	10 A
Main fuse:	30 A

- 3 Turn the key to "ON" and turn on the electrical circuit in question to check if the device operates.
4. If the fuse immediately blows again, have a Yamaha dealer check the electrical system.

EC000103

CAUTION:

Do not use a fuse of a higher amperage rating than recommended to avoid causing extensive damage to the electrical system and possibly a fire.

PERIODIC MAINTENANCE AND MINOR REPAIR

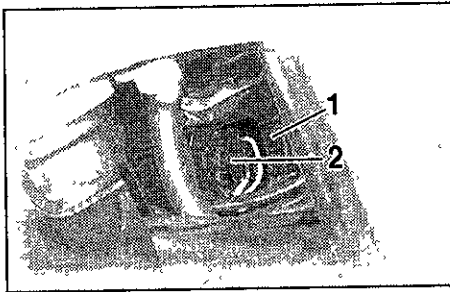

1. Headlight bulb cover
2. Headlight coupler

Replacing the headlight bulb

EAU01802

This motorcycle is equipped with a quartz bulb headlight. If the headlight bulb burns out, replace it as follows

1. Disconnect the headlight coupler, and then remove the headlight bulb cover.

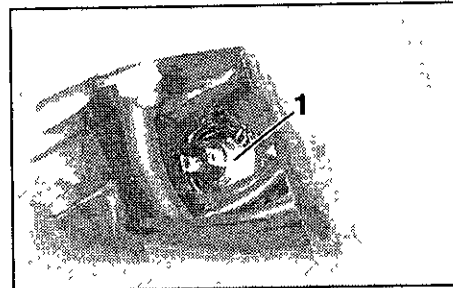

1. Headlight bulb holder
2. Remove the headlight bulb holder by turning it counterclockwise, and then remove the defective bulb.

EW000119

⚠ WARNING

Headlight bulbs get very hot. Therefore, keep flammable products away from a lit headlight bulb, and do not touch the bulb until it has cooled down.

3. Place a new bulb into position, and then secure it with the bulb holder.

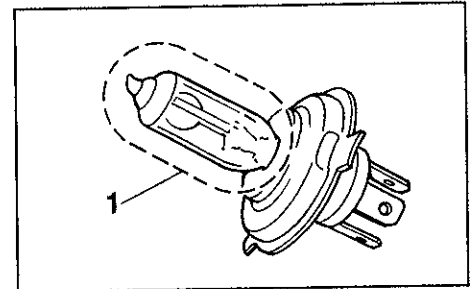

1. Do not touch this area

EC000105

CAUTION

Do not touch the glass part of the headlight bulb to keep it free from oil, otherwise the transparency of the glass, the luminosity of the bulb, and the bulb life will be adversely affected. Thoroughly clean off any dirt and fingerprints on the headlight bulb using a cloth moistened with alcohol or thinner.

4. Install the bulb cover, and then connect the coupler.
5. Have a Yamaha dealer adjust the headlight beam if necessary.

PERIODIC MAINTENANCE AND MINOR REPAIR

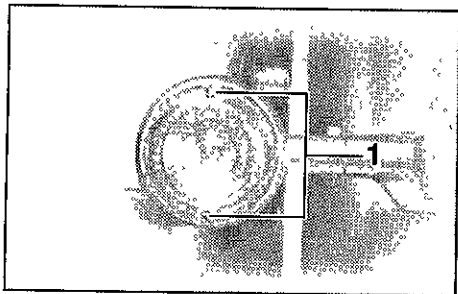

1 Screw (x 2)

Replacing a turn signal light bulb or the tail/brake light bulb

EAU00855

1. Remove the lens by removing the screws.
2. Remove the defective bulb by pushing it in and turning it counter-clockwise.

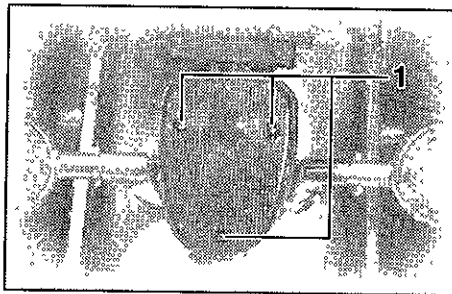

1 Screw (x 3)

3. Insert a new bulb into the socket, push it in, and then turn it clockwise until it stops
4. Install the lens by installing the screws.

EC000108

CAUTION:

Do not overtighten the screws, otherwise the lens may break.

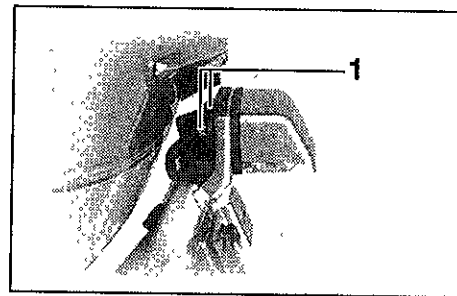

1 Nut (x 3)

Replacing the license plate light bulb

EAU04313

1. Remove the license plate light by removing the nuts.

PERIODIC MAINTENANCE AND MINOR REPAIR

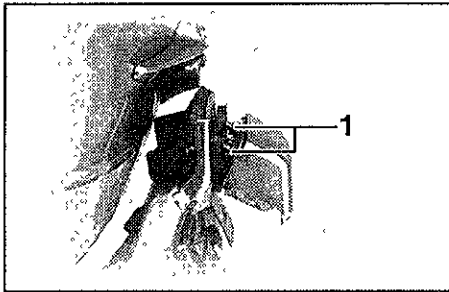

1 Nut (× 2)

2. Remove the license plate light lens by removing the nuts.
3. Remove the defective bulb by pulling it out.
4. Insert a new bulb into the socket.
5. Install the lens by installing the nuts.
6. Install the license plate light by installing the nuts.

ECA00107

CAUTION:

Do not overtighten the nuts, otherwise the lens may break.

EAU01579

Supporting the motorcycle

Since this model is not equipped with a centerstand, follow these precautions when removing the front and rear wheel or performing other maintenance requiring the motorcycle to stand upright. Check that the motorcycle is in a stable and level position before starting any maintenance. A strong wooden box can be placed under the engine for added stability.

To service the front wheel

1. Stabilize the rear of the motorcycle by using a motorcycle stand or, if an additional motorcycle stand is not available, by placing a jack under the frame in front of the rear wheel.
2. Raise the front wheel off the ground by using a motorcycle stand.

To service the rear wheel

Raise the rear wheel off the ground by using a motorcycle stand or, if a motorcycle stand is not available, by placing a jack either under each side of the frame in front of the rear wheel or under each side of the swingarm.

PERIODIC MAINTENANCE AND MINOR REPAIR

EAU03087

Troubleshooting

Although Yamaha motorcycles receive a thorough inspection before shipment from the factory, trouble may occur during operation. Any problem in the fuel, compression, or ignition systems, for example, can cause poor starting and loss of power.

The following troubleshooting charts represent quick and easy procedures for checking these vital systems yourself. However, should your motorcycle require any repair, take it to a Yamaha dealer, whose skilled technicians have the necessary tools, experience, and know-how to service the motorcycle properly.

Use only genuine Yamaha replacement parts. Imitation parts may look like Yamaha parts, but they are often inferior, have a shorter service life and can lead to expensive repair bills.

PERIODIC MAINTENANCE AND MINOR REPAIR

EAU02990

Troubleshooting charts

Starting problems or poor engine performance

EW000125

⚠ WARNING

Keep away open flames and do not smoke while checking or working on the fuel system.

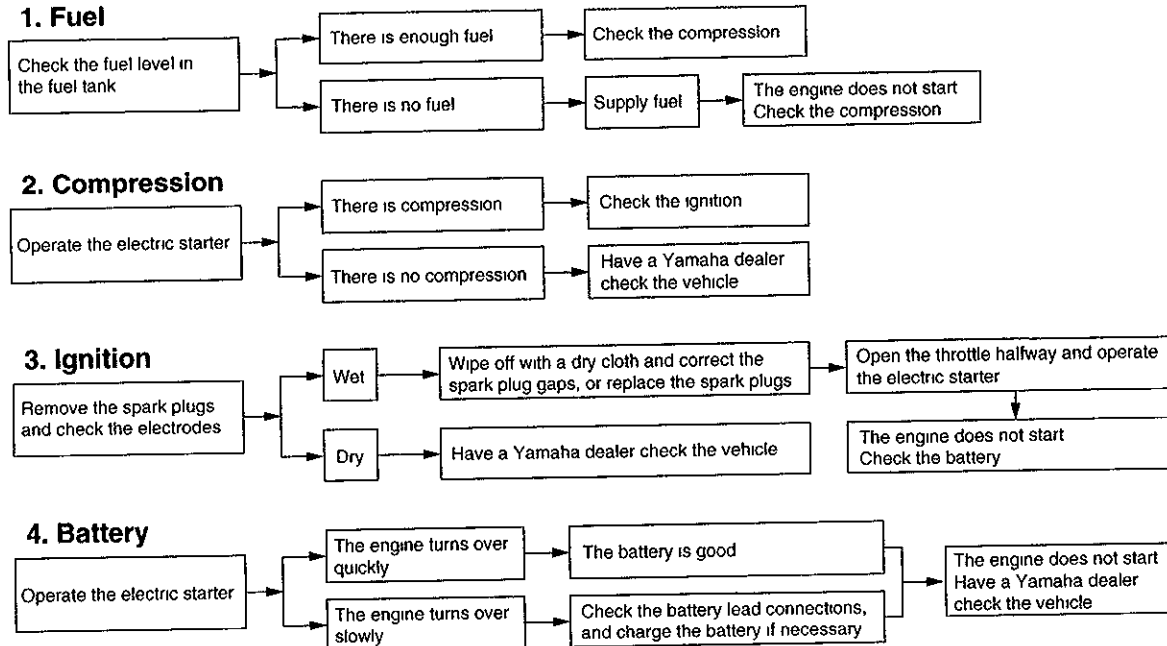

PERIODIC MAINTENANCE AND MINOR REPAIR

Engine overheating

EW000070

WARNING

- Do not remove the radiator cap when the engine and radiator are hot. Scalding hot fluid and steam may be blown out under pressure, which could cause serious injury. Be sure to wait until the engine has cooled.
- After removing the radiator cap retaining bolt, place a thick rag, like a towel, over the radiator cap, and then slowly rotate the cap counterclockwise to the detent to allow any residual pressure to escape. When the hissing sound has stopped, press down on the cap while turning it counterclockwise, and then remove the cap.

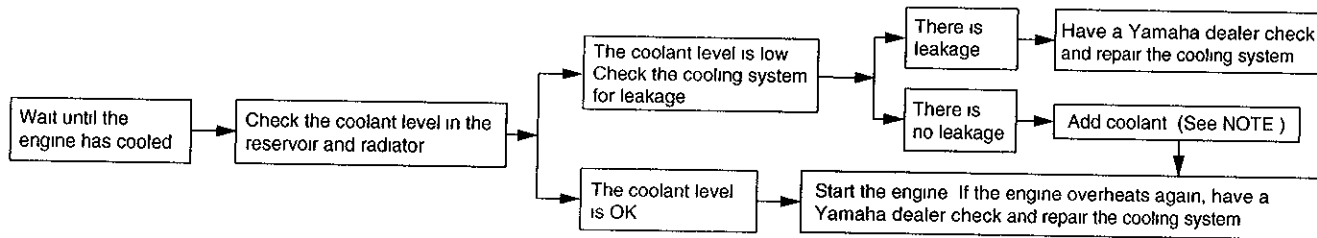

NOTE:

If coolant is not available, tap water can be temporarily used instead, provided that it is changed to the recommended coolant as soon as possible

MOTORCYCLE CARE AND STORAGE

Care	8-1
Storage	8-4

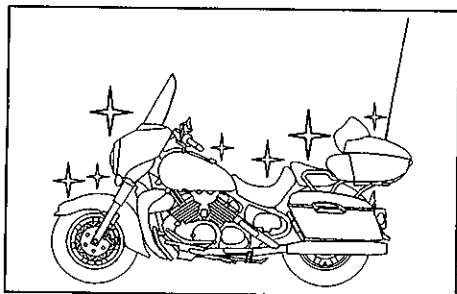

Care

While the open design of a motorcycle reveals the attractiveness of the technology, it also makes it more vulnerable. Rust and corrosion can develop even if high-quality components are used. A rusty exhaust pipe may go unnoticed on a car, however, it detracts from the overall appearance of a motorcycle. Frequent and proper care does not only comply with the terms of the warranty, but it will also keep your motorcycle looking good, extend its life and optimize its performance

8

Before cleaning

1. Cover the muffler outlets with plastic bags after the engine has cooled down.
2. Make sure that all caps and covers as well as all electrical couplers and connectors, including the spark plug caps, are tightly installed.
3. Remove extremely stubborn dirt, like oil burnt onto the crankcase, with a degreasing agent and a brush, but never apply such products onto seals, gaskets and wheel axles. Always rinse the dirt and degreaser off with water.

Cleaning

ECA00036

CAUTION:

- **Avoid using strong acidic wheel cleaners, especially on spoked wheels. If such products are used on hard-to-remove dirt, do not leave the cleaner on the affected area any longer than instructed. Also, thoroughly rinse the area off with water, immediately dry it, and then apply a corrosion protection spray.**
- **Improper cleaning can damage windshields, cowlings, panels and other plastic parts. Use only a soft, clean cloth or sponge with mild detergent and water to clean plastic.**
- **Do not use any harsh chemical products on plastic parts. Be sure to avoid using cloths or sponges which have been in contact with strong or abrasive cleaning products, solvent or**

MOTORCYCLE CARE AND STORAGE

thinner, fuel (gasoline), rust removers or inhibitors, brake fluid, antifreeze or electrolyte.

- Do not use high-pressure washers or steam-jet cleaners since they cause water seepage and deterioration in the following areas: seals (of wheel and swing-arm bearings, fork and brakes), electric components (couplers, connectors, instruments, switches, lights, audio system and speakers), sidecases, travel trunk, breather hoses and vents.

- For motorcycles equipped with a windshield: Do not use strong cleaners or hard sponges as they will cause dulling or scratching. Some cleaning compounds for plastic may leave scratches on the windshield. Test the product on a small hidden part of the windshield to make sure that it does not leave any marks. If the windshield is scratched, use a quality plastic polishing compound after washing.

After normal use

Remove dirt with warm water, a mild detergent, and a soft, clean sponge, and then rinse thoroughly with clean water. Use a toothbrush or bottlebrush for hard-to-reach areas. Stubborn dirt and insects will come off more easily if the area is covered with a wet cloth for a few minutes before cleaning.

After riding in the rain, near the sea or on salt-sprayed roads

Since sea salt or salt sprayed on roads during winter are extremely corrosive in combination with water, carry out the following steps after each ride in the rain, near the sea or on salt-sprayed roads.

NOTE:

Salt sprayed on roads in the winter may remain well into spring.

1. Clean the motorcycle with cold water and a mild detergent, after the engine has cooled down.

ECA00012

CAUTION:

Do not use warm water since it increases the corrosive action of the salt.

2. Apply a corrosion protection spray on all metal, including chrome- and nickel-plated, surfaces to prevent corrosion.

MOTORCYCLE CARE AND STORAGE

After cleaning

1. Dry the motorcycle with a chamois or an absorbing cloth.
2. Use a chrome polish to shine chrome, aluminum and stainless-steel parts, including the exhaust system. (Even the thermally induced discoloring of stainless-steel exhaust systems can be removed through polishing.)
3. To prevent corrosion, it is recommended to apply a corrosion protection spray on all metal, including chrome- and nickel-plated, surfaces.
4. Use spray oil as a universal cleaner to remove any remaining dirt.
5. Touch up minor paint damage caused by stones, etc.
6. Wax all painted surfaces.
7. Let the motorcycle dry completely before storing or covering it.

EWA00001

WARNING

- **Make sure that there is no oil or wax on the brakes or tires. If necessary, clean the brake discs and brake linings with a regular brake disc cleaner or acetone, and wash the tires with warm water and a mild detergent.**
- **Before operating the motorcycle test its braking performance and cornering behavior.**

ECA00013

CAUTION:

- **Apply spray oil and wax sparingly and make sure to wipe off any excess.**
- **Never apply oil or wax to any rubber and plastic parts, but treat them with a suitable care product.**
- **Avoid using abrasive polishing compounds as they will wear away the paint.**

NOTE:

Consult a Yamaha dealer for advice on what products to use

MOTORCYCLE CARE AND STORAGE

ECA00014

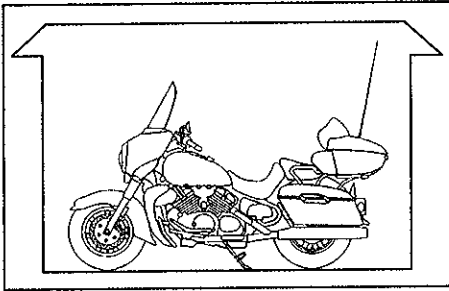

Storage

Short-term

Always store your motorcycle in a cool, dry place and, if necessary, protect it against dust with a porous cover.

CAUTION:

- Storing the motorcycle in a poorly ventilated room or covering it with a tarp, while it is still wet, will allow water and humidity to seep in and cause rust.
- To prevent corrosion, avoid damp cellars, stables (because of the presence of ammonia) and areas where strong chemicals are stored.

Long-term

Before storing your motorcycle for several months:

1. Follow all the instructions in the "Care" section of this chapter.
2. For motorcycles equipped with a fuel cock that has an "OFF" position: Turn the fuel cock lever to "OFF".
3. Drain the carburetor float chamber by loosening the drain bolt; this will prevent fuel deposits from building up. Pour the drained fuel into the fuel tank.
4. Fill up the fuel tank and add fuel stabilizer (if available) to prevent the fuel tank from rusting and the fuel from deteriorating.
5. Perform the following steps to protect the cylinders, piston rings, etc from corrosion.

MOTORCYCLE CARE AND STORAGE

- a. Remove the spark plug caps and spark plugs.
 - b. Pour a teaspoonful of engine oil into each spark plug bore.
 - c. Install the spark plug caps onto the spark plugs, and then place the spark plugs on the cylinder head so that the electrodes are grounded. (This will limit sparking during the next step.)
 - d. Turn the engine over several times with the starter. (This will coat the cylinder walls with oil.)
 - e. Remove the spark plug caps from the spark plugs, and then install the spark plugs and the spark plug caps.
6. Lubricate all control cables and the pivoting points of all levers and pedals as well as of the sidestand/centerstand.
7. Check and, if necessary, correct the tire air pressure, and then lift the motorcycle so that both of its wheels are off the ground. Alternatively, turn the wheels a little every month in order to prevent the tires from becoming degraded in one spot.
8. Cover the muffler outlets with plastic bags to prevent moisture from entering them.
9. Remove the battery and fully charge it. Store it in a cool, dry place and charge it once a month. Do not store the battery in an excessively cold or warm place (less than 0 °C or more than 30 °C). For more information on storing the battery, see page7-33.

NOTE: _____
Make any necessary repairs before storing the motorcycle.

8

 **WARNING**

To prevent damage or injury from sparking, make sure to ground the spark plug electrodes while turning the engine over.

EWA00003

Specifications	9-1
Conversion table	9-5

Specifications

Model	XVZ13TF
Dimensions	
Overall length	2,705 mm
Overall width	900 mm
Overall height	1,565 mm
Seat height	750 mm
Wheelbase	1,705 mm
Minimum ground clearance	155 mm
Minimum turning radius	3,500 mm
Basic weight (with oil and full fuel tank)	394 kg
Engine	
Engine type	Liquid cooled 4-stroke, DOHC
Cylinder arrangement	V-type, 4-cylinder
Displacement	1,294 cm ³
Bore × stroke	79 × 66 mm
Compression ratio	10.1
Starting system	Electric starter
Lubrication system	Wet sump

Engine oil

Type

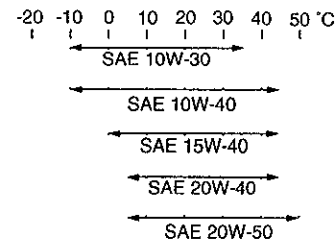

Recommended engine oil classification

API Service SE, SF, SG or higher

CAUTION:

In order to prevent clutch slippage (since the engine oil also lubricates the clutch), do not mix any chemical additives. Do not use oils with a diesel specification of "CD" or oils of a higher quality than specified. In addition, do not use oils labeled "ENERGY CONSERVING II" or higher.

Quantity

Without oil filter cartridge replacement	3.5 L
With oil filter cartridge replacement	3.7 L
Total amount (dry engine)	4.3 L

SPECIFICATIONS

Final gear oil

Type SAE80API "GL-4" Hypoid Gear Oil

Quantity 0.2 L

Cooling system capacity (total amount)

3.5 L

Air filter

Dry type element

Fuel

Type UNLEADED GASOLINE ONLY

Fuel tank capacity 22.5 L

Fuel reserve amount 3.5 L

Carburetor

Manufacturer MIKUNI

Model × quantity BDR32 × 4

Spark plug

Manufacturer/model NGK / DPR8EA-9 or DENSO / X24EPR-U9

Gap 0.8–0.9 mm

Clutch type

Wet, multiple-disc

Transmission

Primary reduction system Spur gear

Primary reduction ratio 1.776

Secondary reduction system Shaft drive

Secondary reduction ratio 2.567

Transmission type Constant-mesh 5-speed

Operation

Left foot

Gear ratio

1st 2.529

2nd 1.632

3rd 1.200

4th 0.960

5th 0.786

Chassis

Frame type Double cradle

Caster angle 29.17°

Trail 152 mm

Tire

Front

Type Tubeless tire

Size 150/80-16 71H

150/80-16 M/C 71H

Manufacturer / model

Dunlop / D404F

Bridgestone / G705

Rear

Type Tubeless tire

Size 150/90B 15 M/C 74H

Manufacturer / model

Dunlop / D404

Bridgestone / G702

SPECIFICATIONS

Maximum load*	190 kg
Tire air pressure (measured on cold tires)	
Up to 90 kg	
Front	250 kPa (2 50 kgf/cm ² , 2 50 bar)
Rear	250 kPa (2 50 kgf/cm ² , 2 50 bar)
90 kg—maximum*	
Front	250 kPa (2 50 kgf/cm ² , 2 50 bar)
Rear	280 kPa (2 80 kgf/cm ² , 2 80 bar)

* Total weight of rider, passenger, cargo and accessories

Wheels

Front		
	Type	Cast wheel
	Size	16 × MT 3 50
		16 M/C × MT 3 50
Rear		
	Type	Cast wheel
	Size	15 M/C × MT 4 00

Brakes

Front		
	Type	Dual disc brake
	Operation	Right hand
	Fluid	DOT 4

Rear		
	Type	Single disc brake
	Operation	Right foot
	Fluid	DOT 4

Suspension

Front	Telescopic fork
Rear	Swingarm (link suspension)

Spring/shock absorber

Front	Coil-air spring / oil damper
Rear	Coil-air spring / oil damper

Wheel travel

Front	140 mm
Rear	105 mm

Electrical

Ignition system	Transistorized coil ignition (digital)	
Charging system		
	Type	A C magneto
	Standard output	14 V, 29 A @ 5,000 r/min
Battery		
	Model	YTX20L-BS
	Voltage, capacity	12 V, 18 Ah
Headlight type	Quartz bulb (halogen)	

Bulb voltage, wattage × quantity

Headlight	12 V, 60/55 W × 1
Tail/brake light	12 V, 5/21 W × 1
Turn signal light	12 V, 21 W × 4
Licence light	12 V, 5 W × 2
Neutral indicator light	12 V, 1.7 W × 1
High beam indicator light	12 V, 1.7 W × 1
Oil level warning light	12 V, 1.7 W × 1
Turn signal indicator light	12 V, 1.7 W × 2
Fuel level warning light	14 V, 3 W × 1
Coolant temperature warning light	12 V, 1.7 W × 1
Overdrive indicator light	12 V, 1.7 W × 1
Engine trouble warning light	12 V, 1.7 W × 1
Cruise control "SET" indicator light	12 V, 1.7 W × 1
Cruise control "RES" indicator light	12 V, 1.7 W × 1
Cruise control "ON" indicator light	12 V, 1.7 W × 1

Audio system amplifier

Output power	
Speaker	14 W × 4
Headset	1 W × 2
Auto-volume range	5 steps

Output impedance

Speaker	4 Ω
Headset	8 Ω–16 Ω

Fuses

Main fuse	30 A
Headlight fuse	15 A
Signaling system fuse	15 A
Ignition fuse	10 A
Radiator fan fuse	10 A
Odometer fuse	10 A
Cruise control fuse	10 A
Carburetor heater fuse	10 A
Audio system fuse	10 A
Auxiliary DC jack fuse	5 A
Auxiliary DC terminal fuse	5 A

SPECIFICATIONS

EAU04513

Conversion table

All specification data in this manual are listed in SI and METRIC UNITS

Use this table to convert METRIC unit values to IMPERIAL unit values.

Example:

METRIC VALUE	CONVERSION FACTOR		IMPERIAL VALUE
2 mm	× 0.03937	=	0.08 in

Conversion table

METRIC SYSTEM TO IMPERIAL SYSTEM			
	Metric unit	Conversion factor	Imperial unit
Torque	m kgf	× 7.233	ft lbf
	m kgf	× 86.794	in lbf
	cm·kgf	× 0.0723	ft lbf
	cm kgf	× 0.8679	in lbf
Weight	kg	× 2.205	lb
	g	× 0.03527	oz
Speed	km/h	× 0.6214	mi/h
Distance	km	× 0.6214	mi
	m	× 3.281	ft
	m	× 1.094	yd
	cm	× 0.3937	in
	mm	× 0.03937	in
Volume, Capacity	cc (cm ³)	× 0.03527	oz (IMP liq)
	cc (cm ³)	× 0.06102	cu in
	L (liter)	× 0.8799	qt (IMP liq)
	L (liter)	× 0.2199	gal (IMP liq)
Miscellaneous	kg/mm	× 55.997	lb/in
	kgf/cm ²	× 14.2234	psf (lbf/in ²)
	°C	× 1.8 + 32	°F

Identification numbers .. .	10-1
Key identification number	10-1
Vehicle identification number	10-1
Model label	10-2
Motorcycle noise regulation	10-2

Identification numbers

Record the key identification number, vehicle identification number and model label information in the spaces provided below for assistance when ordering spare parts from a Yamaha dealer or for reference in case the vehicle is stolen.

EAU02944

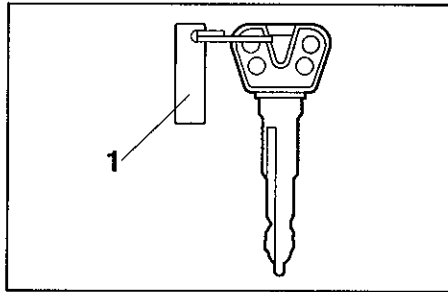

1 Key identification number

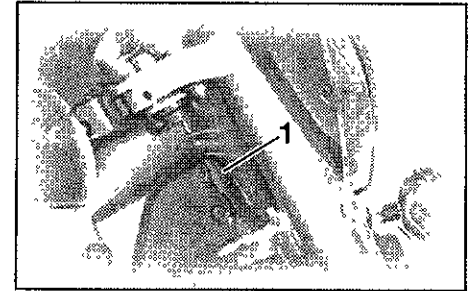

1 Vehicle identification number

1 KEY IDENTIFICATION NUMBER:

2 VEHICLE IDENTIFICATION NUMBER:

3. MODEL LABEL INFORMATION:

EAU01041

Key identification number

The key identification number is stamped into the key tag. Record this number in the space provided and use it for reference when ordering a new key.

EAU01043

Vehicle identification number

The vehicle identification number is stamped into the steering head pipe. Record this number in the space provided.

NOTE: _____
The vehicle identification number is used to identify your motorcycle and may be used to register your motorcycle with the licensing authority in your area

EAU01388*

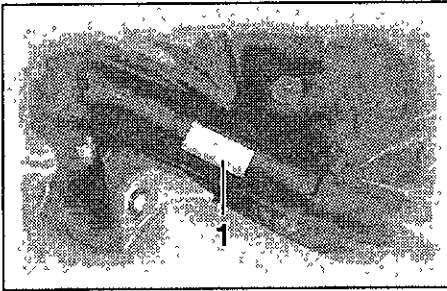

1. Model label

EAU01804

Model label

The model label is affixed to the frame under the rider seat. (See page 3-13 for rider seat removal and installation procedures.) Record the information on this label in the space provided. This information will be needed when ordering spare parts from a Yamaha dealer.

Motorcycle noise regulation

TAMPERING WITH NOISE CONTROL SYSTEM PROHIBITED:

Owners are warned that the law may prohibit:

- (a) The removal or rendering inoperative by any person other than for purposes of maintenance, repair or replacement, of any device or element of design incorporated into any new vehicle for the purpose of noise control prior to its sale or delivery to the ultimate purchaser or while it is in use; and
- (b) The use of the vehicle after such device or element of design has been removed or rendered inoperative by any person.

INDEX

- A**
Air filter elements, cleaning . . . 7-17
Audio settings (basic) . . . 4-4
Audio settings (modes) . . . 4-5
Audio system parts, location of . . . 4-1
Auxiliary audio source . . . 4-17
Auxiliary DC jack and terminals 3-22
- B**
Battery . . . 7-33
Brake and clutch fluid levels, checking . 7-27
Brake and clutch fluids, changing 7-28
Brake and clutch levers, checking and lubricating . . . 7-29
Brake and shift pedals, checking and lubricating . . . 7-29
Brake lever . . . 3-9
Brake lever free play, adjusting 7-24
Brake light switch (rear), adjusting 7-25
Brake pads, checking . . . 7-26
Brake pedal . . . 3-10
Brake pedal position, adjusting 7-25
- C**
Cables, checking and lubricating . . . 7-28
Carburetors, adjusting 7-19
Care . . . 8-1
Cassette deck operation . . . 4-8
CD changer operation . . . 4-16
Clutch lever . . . 3-9
Clutch lever free play 7-24
Conversion table . . . 9-5
Coolant . . . 7-15
 Checking . . . 7-15
- Coolant temperature warning light . . . 3-4
Cowlings and panels, removing and installing . . . 7-6
Cruise control indicator lights . . . 3-3
Cruise control switches . . . 3-8
Cruise control system . . . 3-5
- D**
Dimmer switch . . . 3-7
- E**
Engine break-in . . . 6-5
Engine oil and oil filter cartridge 7-12
Engine stop switch . . . 3-8
Engine trouble warning light . . . 3-3
- F**
Final gear oil . . . 7-15
Front fork, adjusting . . . 3-17
Front fork, checking 7-31
Fuel . . . 3-11
Fuel cock . . . 3-12
Fuel consumption, tips for reducing . . . 6-4
Fuel gauge . . . 3-7
Fuel level warning light . . . 3-3
Fuel tank cap 3-10
Fuses, replacing 7-34
- H**
Handlebar switches . . . 3-7
Headlight bulb, replacing 7-36
Headsets . . . 4-2
Helmet holders 3-14
High beam indicator light 3-2
Horn switch . . . 3-8
- I**
Identification numbers . . . 10-1
Ignition circuit cut-off system . . . 3-20
Indicator and warning lights . . . 3-2
- K**
Key identification number 10-1
- L**
Labels, location . . . 1-7
License plate light bulb, replacing 7-37
Locks for optional side cases and travel trunk . . . 3-19
- M**
Main switch/steering lock 3-1
Model label 10-2
- N**
Neutral indicator light . . . 3-3
Noise regulation . . . 10-2
- O**
Oil level warning light . . . 3-2
Overdrive indicator light 3-3
- P**
Parking . . . 6-6
Part locations 2-1
Pass switch . . . 3-7
Periodic maintenance and lubrication chart . . . 7-3
Pre-operation check list 5-1

R

Radio operation	4-12
Rider seat	3-13

S

Safety information	1-1
Shifting	6-3
Shift pedal	3-9
Shock absorber assembly, adjusting	3-18
Side cases and travel trunk	3-15
Sidestand	3-19
Sidestand, checking and lubricating	7-30
Sound control unit	4-3
Spark plugs, checking	7-10
Specifications	9-1
Speedometer unit	3-4
Starter (choke) knob	3-13
Starting and warming up a cold engine .	6-1
Starting a warm engine	6-3
Start switch	3-8
Steering, checking	7-31
Steering, locking with a padlock	3-13
Storage	8-4
Supporting the motorcycle	7-38

T

Throttle cable free play, adjusting . . .	7-19
Throttle grip and cable, checking and lubricating	7-28
Tires	7-20
Tool kit	7-1
Troubleshooting	7-39
Troubleshooting charts	7-40
Turn signal indicator lights	3-2

Turn signal light or tail/brake light

bulb, replacing	7-37
Turn signal switch	3-8

V

Valve clearance, adjusting	7-20
Vehicle identification number	10-1

W

Wheel bearings, checking	7-32
Wheels	7-23

PRINTED ON RECYCLED PAPER



PRINTED IN JAPAN
2002 06-0 3x1 CR
(E)