

YAMAHA

OWNER'S MANUAL

Virago

XV250S

3LV-28199-29

INTRODUCTION

EAA20301

Congratulations on your purchase of the Yamaha XV250S. This model is the result of Yamaha's vast experience in the production of fine sporting, touring, and pacesetting racing machines. It represents the high degree of craftsmanship and reliability that have made Yamaha a leader in these fields.

This manual will give you an understanding of the operation, inspection, and basic maintenance of this motorcycle. If you have any questions about the operation or maintenance of your motorcycle, please consult a Yamaha dealer.

IMPORTANT MANUAL INFORMATION

EAA10603

Particularly important information is distinguished in this manual by the following notations:



The Safety Alert Symbol means **ATTENTION! BECOME ALERT! YOUR SAFETY IS INVOLVED!**



Failure to follow **WARNING** instructions could result in severe injury or death to the motorcycle operator, a bystander or a person inspecting or repairing the motorcycle.



A **CAUTION** indicates special precautions that must be taken to avoid damage to the motorcycle.

NOTE:

A **NOTE** provides key information to make procedures easier or clearer

EUU00001

NOTE:

- This manual should be considered a permanent part of this motorcycle and should remain with it even if the motorcycle is subsequently sold.
 - Yamaha continually seeks advancements in product design and quality. Therefore, while this manual contains the most current product information available at the time of printing, there may be minor discrepancies between your motorcycle and this manual. If there is any question concerning this manual, please consult your Yamaha dealer.
-

IMPORTANT MANUAL INFORMATION

EUU60100

 **WARNING**

PLEASE READ THIS MANUAL CAREFULLY AND COMPLETELY BEFORE OPERATING THIS MOTORCYCLE.

EAA00100

XV250S

OWNER'S MANUAL

©1997 by Yamaha Motor Co., Ltd.

1st Edition, July 1997

**All rights reserved. Any reprinting or
unauthorized use without the written
permission of Yamaha Motor Co., Ltd.**

is expressly prohibited.

Printed in Japan.

TABLE OF CONTENTS

1	SAFETY INFORMATION	1-1	Steering lock	3-8	
	Safe riding	1-1	Seat.....	3-9	
	Protective apparel	1-3	Helmet holder	3-9	
	Modification	1-3	Rear shock absorber adjustment	3-10	
	Loading and accessories	1-3	Sidestand	3-10	
	Gasoline and exhaust gas	1-5	Sidestand/clutch switch operation check	3-11	
	Location of the important labels	1-7			
2	DESCRIPTION	2-1	4	PRE-OPERATION CHECKS ..	4-1
	Left view	2-1	5	OPERATION AND IMPORTANT RIDING	
	Right view	2-2	POINTS	5-1	
	Controls/Instruments	2-3	Starting and warming up a cold engine	5-1	
			Starting a warm engine.. .. .	5-4	
3	INSTRUMENT AND CONTROL FUNCTIONS ..	3-1	Shifting	5-4	
	Main switch	3-1	Tips for reducing fuel consumption	5-5	
	Indicator lights	3-2	Engine break-in	5-5	
	Handlebar switches	3-2	Parking.....	5-6	
	Speedometer	3-4			
	Clutch lever	3-4	6	PERIODIC MAINTENANCE AND MINOR	
	Shift pedal.....	3-4	REPAIR	6-1	
	Front brake lever	3-5	Tool kit	6-1	
	Rear brake pedal.	3-5	Periodic maintenance and lubrication	6-2	
	Fuel tank cap.	3-6	Engine oil	6-5	
	Fuel.....	3-6	Air filter.	6-7	
	Fuel cock	3-7	Carburetor adjustment	6-9	
	Starter (choke)	3-8	Idle speed adjustment	6-9	

TABLE OF CONTENTS

Valve clearance adjustment	6-10	Fuse replacement	6-26
Spark plug inspection	6-11	Headlight bulb replacement	6-27
Tires	6-12	Supporting the motorcycle	6-28
Wheels	6-13	Front wheel removal.	6-29
Throttle cable free play inspection.	6-14	Front wheel installation	6-29
Front brake lever free play adjustment.	6-14	Rear wheel removal	6-30
Rear brake pedal height and free play adjustment.	6-15	Rear wheel installation	6-31
Brake light switch adjustment	6-16	Troubleshooting	6-32
Checking the front brake pads and rear brake shoes	6-16	Troubleshooting chart	6-33
Inspecting the brake fluid level	6-17	7 CLEANING AND STORAGE	7-1
Brake fluid replacement	6-18	A. Cleaning.	7-1
Clutch lever free play adjustment	6-18	B. Storage	7-2
Drive chain slack check	6-19	8 SPECIFICATIONS	8-1
Drive chain slack adjustment	6-19	Specifications	8-1
Drive chain lubrication	6-21	9 CONSUMER INFORMATION	9-1
Cable inspection and lubrication.	6-21	How to use the conversion table	9-1
Throttle cable and grip lubrication	6-21	Identification numbers record	9-2
Brake and shift pedal lubrication	6-22	Key identification number	9-2
Brake and clutch lever lubrication.	6-22	Vehicle identification number	9-2
Sidestand lubrication	6-22	Model label	9-3
Front fork inspection	6-23	NOISE REGULATION (FOR Australia)	9-3
Steering inspection	6-23		
Wheel bearings.	6-24		
Battery	6-24		



SAFETY INFORMATION

EUU75302

1

TWO-WHEELED MOTORCYCLES ARE SINGLE TRACK VEHICLES THEIR SAFE USE AND OPERATION ARE DEPENDENT UPON THE USE OF PROPER RIDING TECHNIQUES AS WELL AS THE EXPERTISE OF THE OPERATOR EVERY OPERATOR SHOULD KNOW THE FOLLOWING REQUIREMENTS BEFORE RIDING

HE OR SHE SHOULD

- 1 OBTAIN THOROUGH INSTRUCTIONS FROM A COMPETENT SOURCE ON ALL ASPECTS OF MOTORCYCLE OPERATION.
- 2 OBSERVE THE WARNINGS AND MAINTENANCE REQUIREMENTS IN THE OWNER'S MANUAL.
3. OBTAIN QUALIFIED TRAINING IN SAFE AND PROPER RIDING TECHNIQUES.
- 4 OBTAIN PROFESSIONAL TECHNICAL SERVICE AS INDICATED BY THE OWNER'S MANUAL AND/OR WHEN MADE NECESSARY BY MECHANICAL CONDITIONS.

Safe riding

- 1 Always make pre-operation checks Careful checks may help prevent an accident
2. This motorcycle is designed to carry the operator and a passenger.
3. The failure of motorists to detect and recognize motorcycles in traffic is the predominating cause of automobile/motorcycle accidents. Many accidents have been caused by an automobile driver who did not see the motorcycle. Making yourself conspicuous appears to be very effective in reducing the chance of this type of accident.

Therefore.

- a. Wear a brightly colored jacket.
- b. Use extra caution when you approach and pass through intersections, since intersections are the most likely places for motorcycle accidents.
- c Ride where other motorists can see you. Avoid riding in another motorist's "blind spot".



SAFETY INFORMATION

4. Many accidents involve inexperienced operators. In fact, many operators who have been involved in accidents do not even have a current motorcycle license.
 - a. Make sure you are qualified. Also, only lend your motorcycle to experienced operators
 - b. Know your skills and limits. Staying within your limits may help you to avoid an accident
 - c. We recommend that you practice riding your motorcycle where there is no traffic until you have become thoroughly familiar with your motorcycle and all of its controls.
5. Many motorcycle accidents have been caused by motorcycle operator errors. A typical error made by the operator is veering wide on a turn due to EXCESSIVE SPEED or undercornering (insufficient lean angle for the speed).
 - a. Always obey the speed limits and never travel faster than warranted by road and traffic conditions
 - b. Always signal before turning or changing lanes. Make sure other motorists see you
6. The operator's and passenger's posture are important for proper control.
 - a. The operator should keep both hands on the handlebars and both feet on the operator footrests during operation to maintain control of the motorcycle.
 - b. The passenger should always hold on to the operator, or the seat strap or grab bar if the motorcycle is so equipped, with both hands and keep both feet on the passenger footrests.
 - c. Never carry a passenger unless he or she can firmly place both feet on the passenger footrests
7. Never ride under the influence of alcohol or drugs.
8. This motorcycle is designed for on-road use only. It is not suitable for off-road use



SAFETY INFORMATION

1

Protective apparel

The majority of fatalities from motorcycle accidents are the result of head injuries. The use of a safety helmet is the single most critical factor in the prevention or reduction of head injuries

1. Always wear an approved helmet.
2. Wear a face shield or goggles. Wind on your unprotected eyes could contribute to an impairment of vision which could delay seeing a hazard.
3. The use of heavy boots, jacket, trousers, gloves, etc. is effective in preventing or reducing abrasions or lacerations.
4. Never wear loose fitting clothing. It could catch on the control levers, footrests, or wheels and cause injury or accident.
5. Never touch the engine or exhaust system during or after operation. They become very hot and can cause burns. Always wear protective clothing that covers your legs, ankles, and feet.
6. A passenger should also observe the above precautions.

Modification

Modifications made to the motorcycle not approved by Yamaha, or the removal of original equipment, may render your motorcycle unsafe for use and may cause severe personal injury. Modifications may also make your motorcycle illegal to use.

Loading and accessories

Adding accessories or cargo to your motorcycle can adversely affect stability and handling if the weight distribution of the machine is changed. To avoid the possibility of an accident, extreme caution should be used if adding cargo or accessories to your motorcycle. Use extra care if riding a motorcycle which has added cargo or accessories. Here are some general guidelines to follow if loading cargo or adding accessories to your motorcycle.



Loading

The total weight of the operator, passenger, accessories and cargo must not exceed the maximum load limit of 183 kg.

When loading within these weight limits, keep the following in mind:

1. Cargo and accessory weight should be kept as low and close to the motorcycle as possible. Be sure to distribute the weight as evenly as possible on both sides of the machine to minimize imbalance or instability.
2. Shifting weights can create a sudden imbalance. Make sure that accessories and cargo are securely attached to the motorcycle before riding. Recheck accessory mounts and cargo restraints frequently.
3. Never attach any large or heavy items to the handlebars, front forks, or front fender. These items, including such cargo as sleeping bags, duffle bags, or tents, can create unstable handling or slow steering response

Accessories

Genuine Yamaha accessories have been specifically designed for use on this motorcycle. Since Yamaha cannot test all other accessories which may be available, you must personally be responsible for the proper selection, installation and use of non-Yamaha accessories. You should use extreme caution when selecting and installing any accessories.

Keep in mind these guidelines for mounting accessories in addition to those provided under "LOADING"

1. Never install accessories or carry cargo that would impair the performance of your motorcycle. Carefully inspect the accessory before using it to make sure it does not in any way reduce ground clearance or cornering clearance, limit suspension travel, steering travel or control operation, or obscure lights or reflectors.



SAFETY INFORMATION

1

- a. Accessories fitted to the handlebar or the front fork area can create instability due to improper weight distribution or aerodynamic changes. If accessories are added to the handlebar or front fork area, they must be as lightweight as possible and should be kept to a minimum.
 - b. Bulky or large accessories may seriously affect the stability of the motorcycle due to aerodynamic effects. Wind may attempt to lift the motorcycle, or the motorcycle may become unstable in cross winds. These accessories may also cause instability when being passed by or passing large vehicle.
 - c. Certain accessories can displace the operator from his or her normal riding position. This improper position limits the freedom of movement of the operator and may limit control ability. Therefore such accessories are not recommended.
2. Caution must be used if adding electrical accessories. If these accessories exceed the capacity of the motorcycle's electrical system, an electric failure could result, which could cause a dangerous loss of lights or engine power.

Gasoline and exhaust gas

1. **GASOLINE IS HIGHLY FLAMMABLE.**
 - a. Always turn off the engine when refueling.
 - b. Take care not to spill any gasoline on the engine or exhaust system when refueling.
 - c. Never refuel while smoking or in the vicinity of an open flame.
2. Never start the engine or let it run for any length of time in a closed area. The exhaust fumes are poisonous and may cause loss of consciousness and death within a short time. Always operate your motorcycle in an area that has adequate ventilation.
3. Always turn off the engine before leaving the motorcycle unattended and remove the ignition key. When parking the motorcycle, note the following:



SAFETY INFORMATION

- a The engine and exhaust system may be hot. Park the motorcycle in a place where pedestrians or children are not likely to touch these hot areas.
 - b. Do not park the motorcycle on a slope or soft ground, the motorcycle may fall over
 - c Do not park the motorcycle near a flammable source, e.g. a kerosene heater, or near an open flame. The motorcycle could catch fire.
- 4 When transporting the motorcycle in another vehicle, be sure it is kept upright and that the fuel cock is turned to "ON" or "RES" (for vacuum type)/"OFF" (for manual type). If it should lean over, gasoline may leak out of the carburetor or fuel tank
 - 5 If you should swallow any gasoline, inhale a lot of gasoline vapor, or allow gasoline to get in your eyes, see your doctor immediately. If any gasoline spills on your skin or clothing, immediately wash it off with soap and water and change your clothes.



SAFETY INFORMATION

LOCATION OF THE IMPORTANT LABELS

EAA40000

Please read the following labels carefully before operating this motorcycle

1

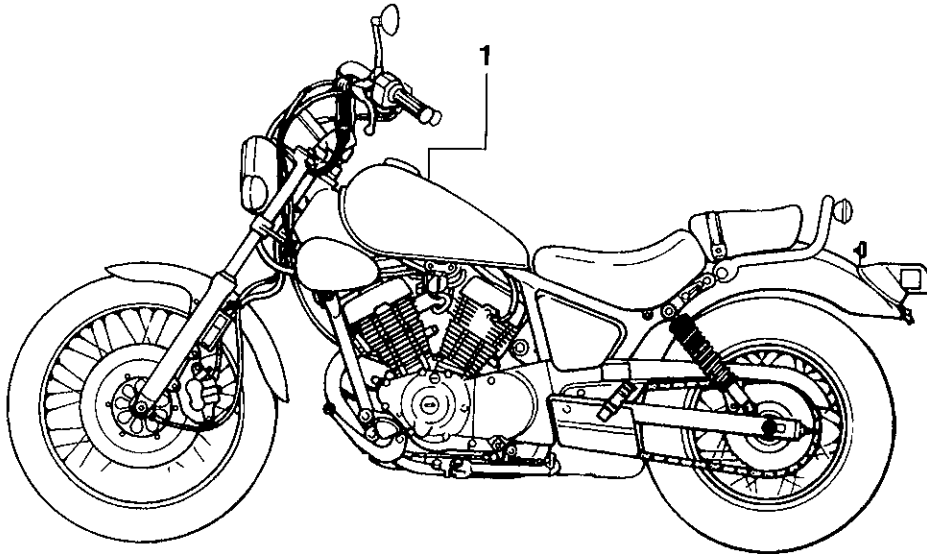



SAFETY INFORMATION

1

WARNING	
Before you operate this vehicle, read the owner's manual	
English	3HP-21568-00

1

Left view

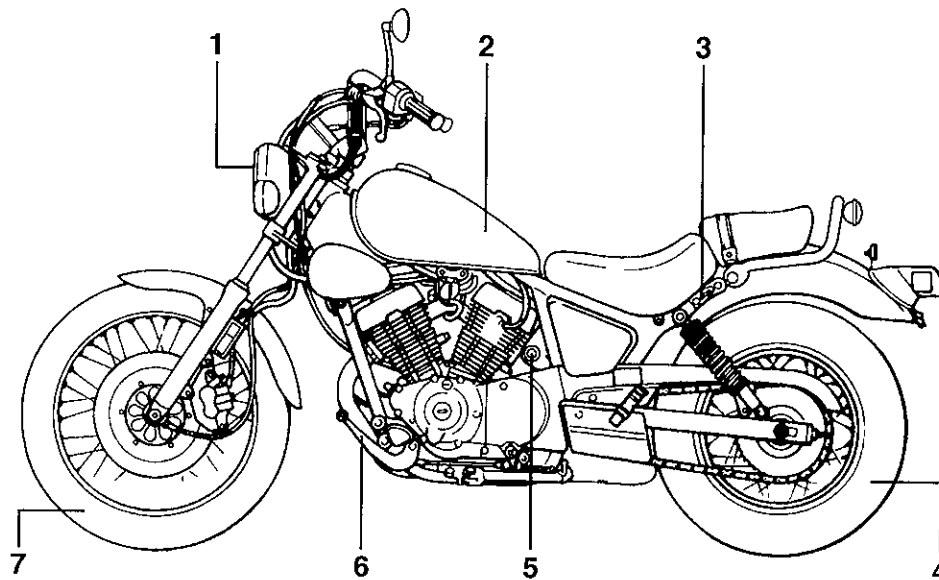

1. Headlight

(page 6-27)

2. Fuel tank

(page 3-6)

3. Helmet holder

(page 3-9)

4. Rear wheel

(page 6-30)

5. Main switch

(page 3-1)

6. Shift pedal

(page 3-4)

7. Front wheel

(page 6-29)

Right view

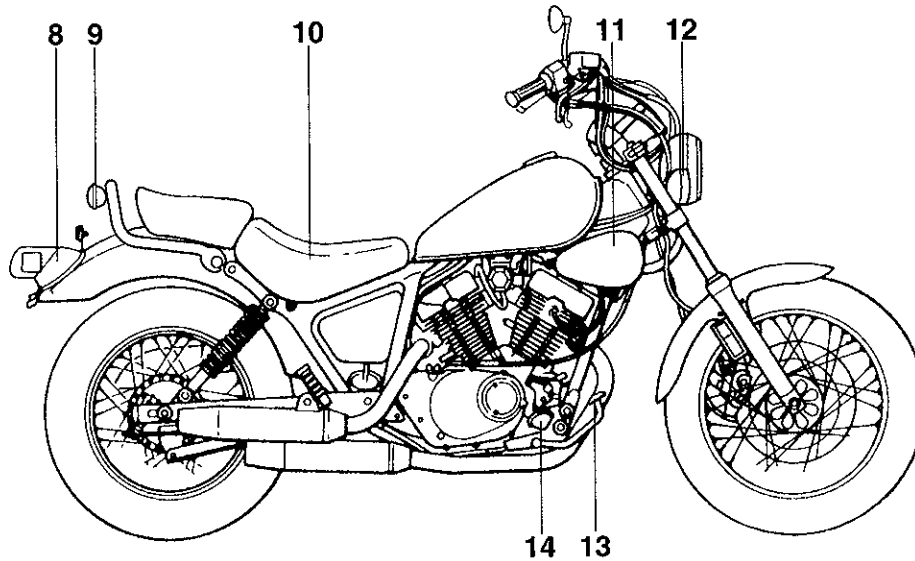

- 8. Tail/Brake light
- 9. Rear flasher light
- 10. Rider seat
- 11. Air filter

(page 6-16)
(page 3-9)
(page 6-7)

- 12. Front flasher light
- 13. Rear brake pedal
- 14. Footrest

(page 3-5)

DESCRIPTION

Controls/Instruments

2

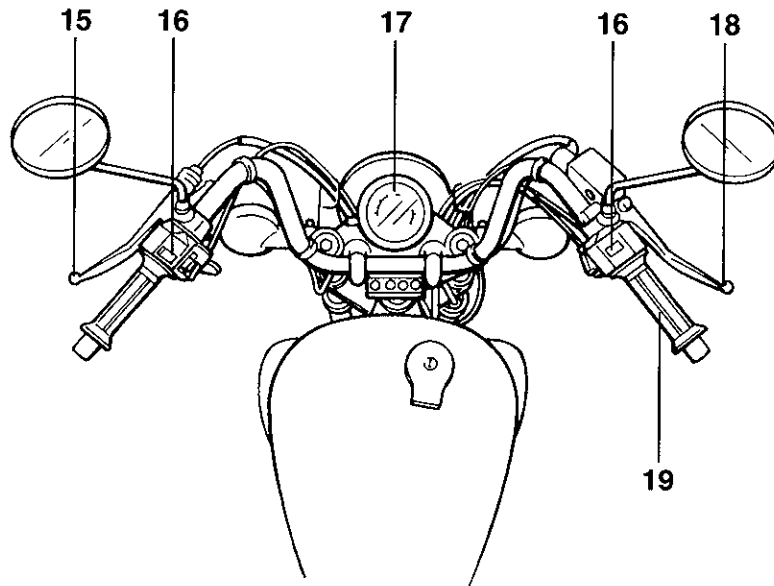

- | | |
|------------------------|-------------|
| 15. Clutch lever | (page 3-4) |
| 16. Handlebar switches | (page 3-2) |
| 17. Speedometer | (page 3-4) |
| 18. Front brake lever | (page 3-5) |
| 19. Throttle grip | (page 6-14) |

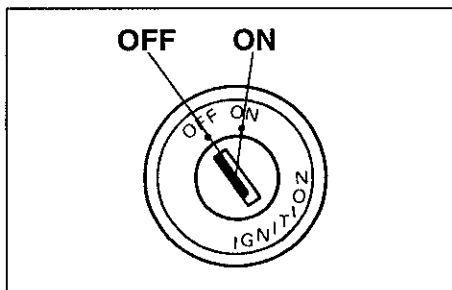

EAB00100

Main switch

The main switch controls the ignition and lighting systems. Its operation is described below

EAB01300

ON.

Electrical circuits are switched on, and the headlight, meter light, and taillight come on. The engine can be started. The key cannot be removed in this position.

EAB00600

OFF.

All electrical circuits are switched off. The key can be removed in this position.

EUU08800

NOTE:

Always turn the main switch to "OFF" and remove the key when the motorcycle is unattended.

INSTRUMENT AND CONTROL FUNCTIONS

3

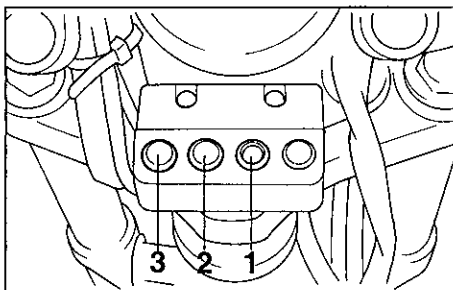

- 1 Turn indicator light "TURN"
- 2 Neutral indicator light "NEUTRAL"
- 3 High beam indicator light "HIGH BEAM"

EAB10000

Indicator lights

EAB12403

Turn indicator light "TURN"

This indicator flashes when the turn switch is moved to the left or right.

EAB10201

Neutral indicator light "NEUTRAL"

This indicator comes on when the transmission is in neutral.

EAB10301

High beam indicator light "HIGH BEAM"

This indicator comes on when the headlight high beam is used

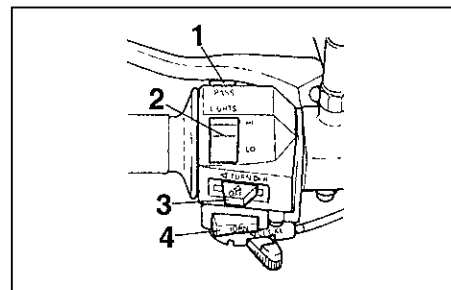

- 1 Pass switch "PASS"
- 2 Dimmer switch "LIGHTS"
- 3 Turn signal switch "TURN"
- 4 Horn switch "HORN"

EAB60000

Handlebar switches

EAB63201

Pass switch "PASS"

Press the switch to operate the passing light.

EAB60101

Dimmer switch "LIGHTS"

Turn the switch to "HI" for the high beam and to "LO" for the low beam

INSTRUMENT AND CONTROL FUNCTIONS

EAB62102

Turn signal switch "TURN"

To signal a right-hand turn, push the switch to the right. To signal a left-hand turn, push the switch to the left. Once the switch is released it will return to the center position. To cancel the signal, push the switch in after it has returned to the center position.

EAB60201

Horn switch "HORN"

Press the switch to sound the horn

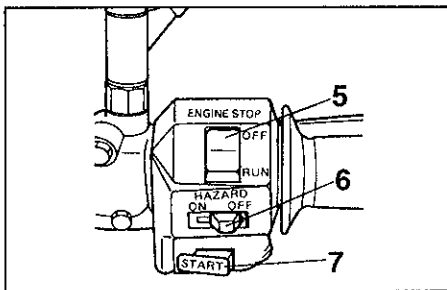

- 5 Engine stop switch "ENGINE STOP"
- 6 Hazard switch "HAZARD"
- 7 Start switch "START"

EAB62802

Hazard switch "HAZARD"

The hazard switch should be turned on under emergency or hazardous conditions. All turn signal lights will flash simultaneously when this switch is turned on with the main switch in the "ON" position

EUU46100

CAUTION:

The battery can discharge from extended use, making it difficult to operate the starter.

EUU01101

NOTE:

Turn on the hazard switch to warn other drivers if your motorcycle must be stopped where it might be a traffic hazard.

EAB60902

Engine stop switch "ENGINE STOP"

The engine stop switch is a safety device for use in an emergency such as when the motorcycle overturns or if trouble occurs in the throttle system. Turn the switch to "RUN" to start the engine. In case of emergency, turn the switch to "OFF" to stop the engine

EAB60703

Start switch "START"

The starter motor cranks the engine when pushing the start switch.

EUU30700

CAUTION:

See starting instructions prior to starting the engine.

INSTRUMENT AND CONTROL FUNCTIONS

3

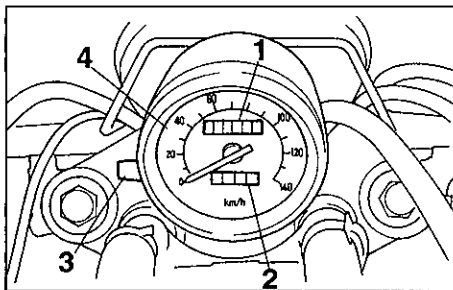

- 1 Odometer
- 2 Trip odometer
- 3 Reset knob
- 4 Speedometer

EAB40005

Speedometer

The speedometer shows riding speed. This speedometer is equipped with an odometer and trip odometer. The trip odometer can be reset to "0" with the reset knob. Use the trip odometer to estimate how far you can ride on a tank of fuel. This information will enable you to plan fuel stops in the future.

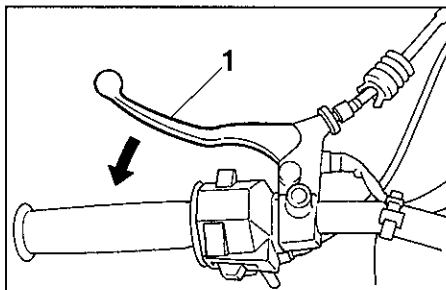

- 1 Clutch lever

EAB70003

Clutch lever

The clutch lever is located on the left handlebar, and the ignition circuit cut-off system is incorporated in the clutch lever holder. Pull the clutch lever to the handlebar to disengage the clutch, and release the lever to engage the clutch. The lever should be pulled rapidly and released slowly for smooth clutch operation. (Refer to the engine starting procedures for a description of the ignition circuit cut-off system.)

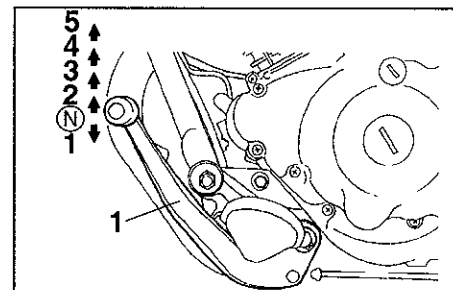

- 1 Shift pedal
- N Neutral

EAB80001

Shift pedal

This motorcycle is equipped with a constant-mesh 5-speed transmission. The shift pedal is located on the left side of the engine and is used in combination with the clutch when shifting.

INSTRUMENT AND CONTROL FUNCTIONS

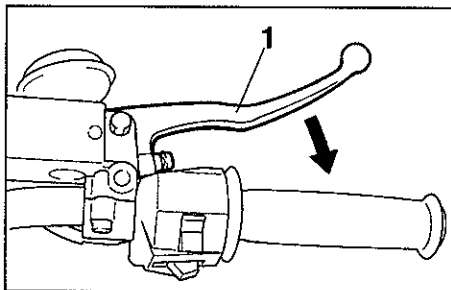

1 Front brake lever

EAB90001

Front brake lever

The front brake lever is located on the right handlebar. Pull it toward the handlebar to apply the front brake.

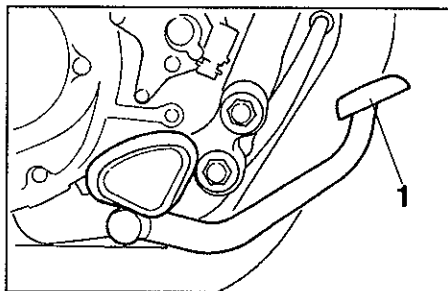

1 Rear brake pedal

EAB90101

Rear brake pedal

The rear brake pedal is on the right side of the motorcycle. Press down on the brake pedal to apply the rear brake.

INSTRUMENT AND CONTROL FUNCTIONS

3

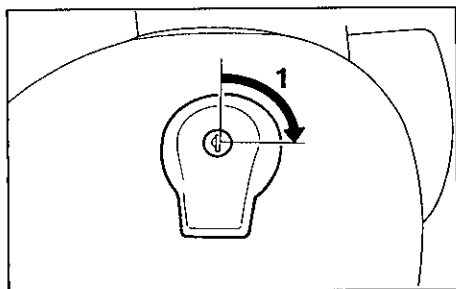

1 Open

EAC00101

Fuel tank cap

TO OPEN:

Insert the key and turn it 1/4 turn clockwise. The lock will be released and the cap can be opened.

TO CLOSE

Push the tank cap into position with the key inserted. To remove the key, turn it counterclockwise to the original position.

EUU01200

NOTE: This tank cap cannot be closed unless the key is in the lock. The key cannot be removed if the cap is not locked properly.

EUU61100

WARNING

Be sure the cap is properly installed and locked in place before riding the motorcycle.

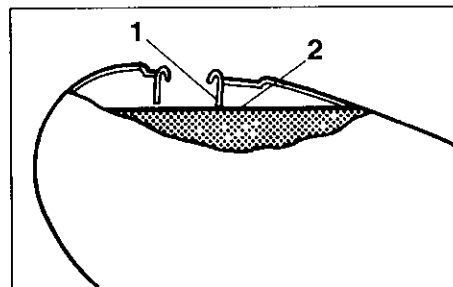

- 1 Filler tube
- 2 Fuel level

EAE80000

Fuel

Make sure there is sufficient fuel in the tank.

EUU61000

WARNING

Do not overfill the fuel tank. Avoid spilling fuel on the hot engine. Do not fill the fuel tank above the bottom of the filler tube as shown in the illustration or it may overflow when the fuel heats up later and expands.

INSTRUMENT AND CONTROL FUNCTIONS

EUU39302

CAUTION:

Always wipe off spilled fuel immediately with a dry and clean soft cloth. Fuel may deteriorate painted surfaces or plastic parts.

EAEB0900

Recommended fuel
Regular gasoline
For Australia,
Unleaded fuel only
Fuel tank capacity:
Total
9.5 L
Reserve:
2.6 L

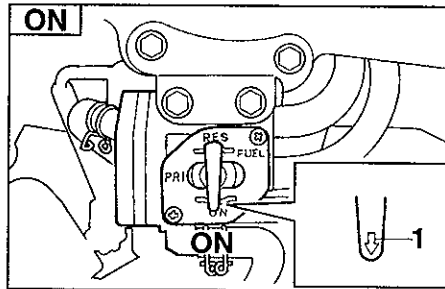

1 Arrow mark

EAC10300

Fuel cock

The negative pressure fuel cock supplies fuel from the tank to the carburetor while filtering it also

The fuel cock has the following three positions:

ON: With the lever in this position, fuel flows if the engine is running, but stops if the engine is not running.

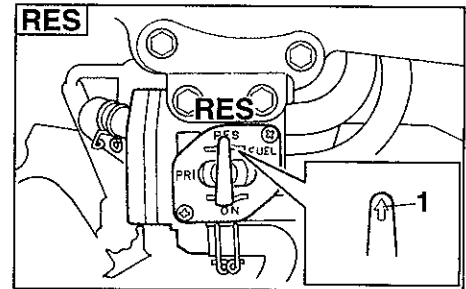

1 Arrow mark

RES: This indicates reserve. If you run out of fuel while riding, move the lever to "PRI", start the engine, then move the lever to "RES" FILL THE TANK AT THE FIRST OPPORTUNITY. BE SURE TO MOVE THE LEVER TO "ON" AFTER REFUELING.

EUU01400

NOTE:

The fuel cock operates on vacuum from the engine when set at "ON" or "RES". If the line connecting the cock to the carburetor intake manifold is not connected or has a leak, the cock will not function properly.

INSTRUMENT AND CONTROL FUNCTIONS

3

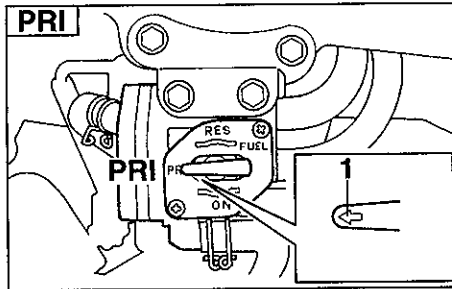

1 Arrow mark

PRI This indicates prime. With the lever in this position, fuel flows whether the engine is running or not. If the fuel tank is completely empty, refill the tank and move the lever to "PRI" to prime the carburetor. Move the lever to "ON" after starting the engine

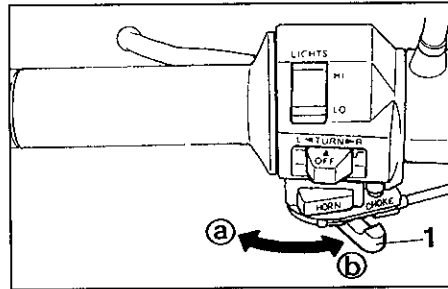

1 Starter (choke)

Starter (choke)

Starting a cold engine requires a richer air-fuel mixture. A separate starter circuit supplies this mixture

Move in direction (a) to turn on the starter (choke)

Move in direction (b) to turn off the starter (choke)

EAC21400

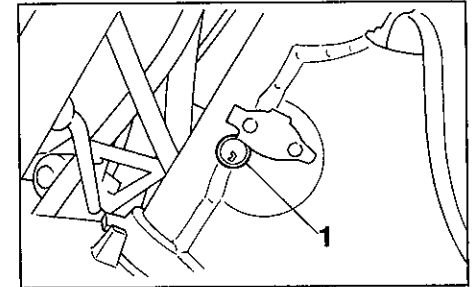

1 Steering lock

Steering lock

To lock the steering, turn the handlebars all the way to the right. Open the steering lock cover, turn the key 1/8 counterclockwise then push the key in and turn it 1/8 turn clockwise. After checking to see that the steering is locked, remove the key from the lock and close the cover. To release the lock, reverse the above procedure

EAC30201

INSTRUMENT AND CONTROL FUNCTIONS

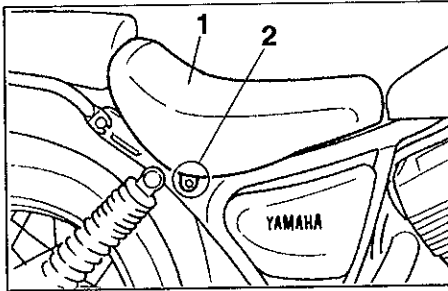

- 1 Rider seat
- 2 Bolt (x 2)

EAC41504

Seat

To remove the rider seat, remove the bolts.

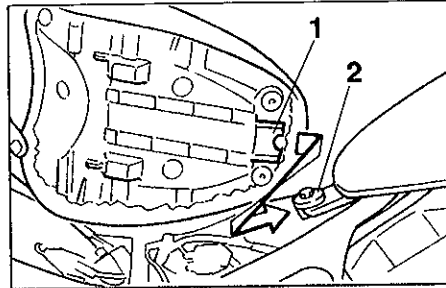

- 1 Projection
- 2. Seat holder

To reinstall the rider seat, insert the projection on the front of the seat into the seat holder, then tighten the bolts

EUU01700

NOTE:

Make sure that the seat is securely fitted.

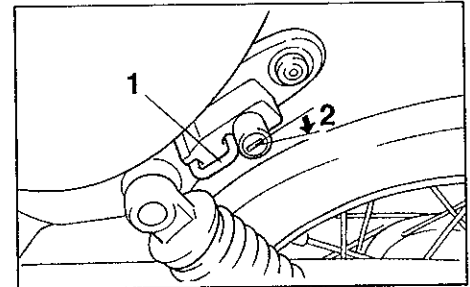

- 1 Helmet holder
- 2 Open

EAC50001

Helmet holder

To open the helmet holder, insert the key in the lock and turn it as shown. To lock the helmet holder, replace the holder in its original position.

EUU72900

! WARNING

Never ride with a helmet in the helmet holder. The helmet may hit objects, causing loss of control and possibly an accident.

INSTRUMENT AND CONTROL FUNCTIONS

EAD20101

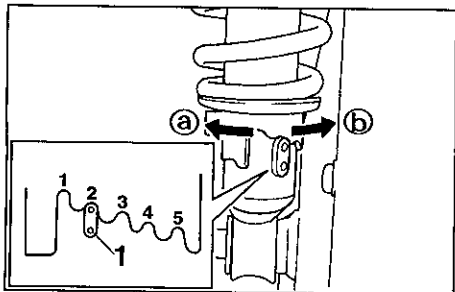

1 Position indicator

EAI50904

Rear shock absorber adjustment

Each shock absorber is equipped with a spring preload adjusting ring. Adjust spring preload as follows. Turn the adjusting ring in direction (a) to increase spring preload and in direction (b) to decrease spring preload. Make sure that the appropriate notch in the adjusting ring is aligned with the position indicator on the rear shock absorber

	Soft	Standard	Hard		
Adjusting position	1	2	3	4	5

EUU65200

⚠ WARNING

Always adjust each shock absorber to the same setting. Uneven adjustment can cause poor handling and loss of stability.

Sidestand

This model is equipped with an ignition circuit cut-off system. The motorcycle must not be ridden when the sidestand is down. The sidestand is located on the left side of the frame. (Refer to page 5-1 for an explanation of this system.)

EUU68901

⚠ WARNING

This motorcycle must not be operated with the sidestand in the down position. If the stand is not properly retracted, it could contact the ground and distract the operator, resulting in a possible loss of control. Yamaha has designed into this motorcycle a lockout system to assist the operator in fulfilling the responsibility of retracting the sidestand. Please check carefully the operating instructions listed below and if there is any indication of a malfunction, return the motorcycle to a Yamaha dealer immediately for repair.

INSTRUMENT AND CONTROL FUNCTIONS

EAD30802

Sidestand/clutch switch operation check

Check the operation of the sidestand switch and clutch switch against the information below

TURN THE MAIN SWITCH TO "ON" AND THE ENGINE STOP SWITCH TO "RUN"

TRANSMISSION IS IN GEAR AND SIDESTAND IS UP

PULL IN CLUTCH LEVER AND PUSH THE START SWITCH

ENGINE WILL START.

CLUTCH SWITCH IS OK

SIDESTAND IS DOWN

ENGINE WILL STALL

SIDESTAND SWITCH IS OK.

EUU69100

WARNING

If improper operation is noted, consult a Yamaha dealer immediately.

PRE-OPERATION CHECKS

EAE00001

Owners are personally responsible for their vehicle's condition. Your motorcycle's vital functions can start to deteriorate quickly and unexpectedly, even if it remains unused (for instance, if it is exposed to the elements). Any damage, fluid leak or loss of tire pressure could have serious consequences. Therefore, it is very important that, in addition to a thorough visual inspection, you check the following points before each ride.

ITEM	CHECKS	PAGE
Front brake	<ul style="list-style-type: none">• Check operation, free play, fluid level and fluid leakage• Fill with DOT 4 (or DOT 3) brake fluid if necessary	6-14 ~ 6-18
Rear brake	<ul style="list-style-type: none">• Check operation, condition and free play• Adjust if necessary	
Clutch	<ul style="list-style-type: none">• Check operation, condition and free play• Adjust if necessary	6-18
Throttle grip and housing	<ul style="list-style-type: none">• Check for smooth operation• Lubricate if necessary	6-14
Engine oil	<ul style="list-style-type: none">• Check oil level• Fill with oil if necessary	6-5 ~ 6-7
Drive chain	<ul style="list-style-type: none">• Check chain slack and condition• Adjust if necessary	6-19 ~ 6-21
Wheels and tires	<ul style="list-style-type: none">• Check tire pressure, wear, damage and spoke tightness• Tighten spokes if necessary	6-12 ~ 6-13, 6-29 ~ 6-31
Control and meter cables	<ul style="list-style-type: none">• Check for smooth operation• Lubricate if necessary	6-21
Brake and shift pedal shafts	<ul style="list-style-type: none">• Check for smooth operation• Lubricate if necessary	6-22
Brake and clutch lever pivots	<ul style="list-style-type: none">• Check for smooth operation• Lubricate if necessary	6-22
Sidestand pivot	<ul style="list-style-type: none">• Check for smooth operation• Lubricate if necessary	6-22

PRE-OPERATION CHECKS

ITEM	CHECKS	PAGE
Chassis fasteners	<ul style="list-style-type: none">• Make sure that all nuts, bolts and screws are properly tightened.• Tighten if necessary	—
Fuel tank	<ul style="list-style-type: none">• Check fuel level• Fill with fuel if necessary.	3-6 ~ 3-7
Lights, signals and switches	<ul style="list-style-type: none">• Check for proper operation	6-27 ~ 6-28
Battery	<ul style="list-style-type: none">• Check fluid level.• Fill with distilled water if necessary.	6-24 ~ 6-25

NOTE:

Pre-operation checks should be made each time the motorcycle is used. Such an inspection can be thoroughly accomplished in a very short time, and the added safety it assures is more than worth the time involved.

WARNING

If any item in the Pre-Operation Check is not working properly, have it inspected and repaired before operating the motorcycle.

OPERATION AND IMPORTANT RIDING POINTS

EAF00000

5

EUU67201

WARNING

1. Before riding this motorcycle, become thoroughly familiar with all operating controls and their functions. Consult a Yamaha dealer regarding any control or function that you do not thoroughly understand.
2. Never start your engine or let it run for any length of time in a closed area. The exhaust fumes are poisonous and can cause loss of consciousness and death within a short time. Always operate your motorcycle in an area with adequate ventilation.
3. Before starting out, always be sure the sidestand is up. Failure to retract the sidestand completely can result in a serious accident when you try to turn a corner.

EAF19800*

Starting and warming up a cold engine

EUU07401

NOTE:

This motorcycle is equipped with an ignition circuit cut-off system.

- 1 The engine can be started only under the following conditions:
 - a. The transmission is in neutral.
 - b. The sidestand is up, the transmission is in gear and the clutch is disengaged.
- 2 The motorcycle must not be ridden when the sidestand is down.

EUU69200

WARNING

Before going through the following steps, check the function of the sidestand switch and clutch switch. (Refer to page 3-11.)

OPERATION AND IMPORTANT RIDING POINTS

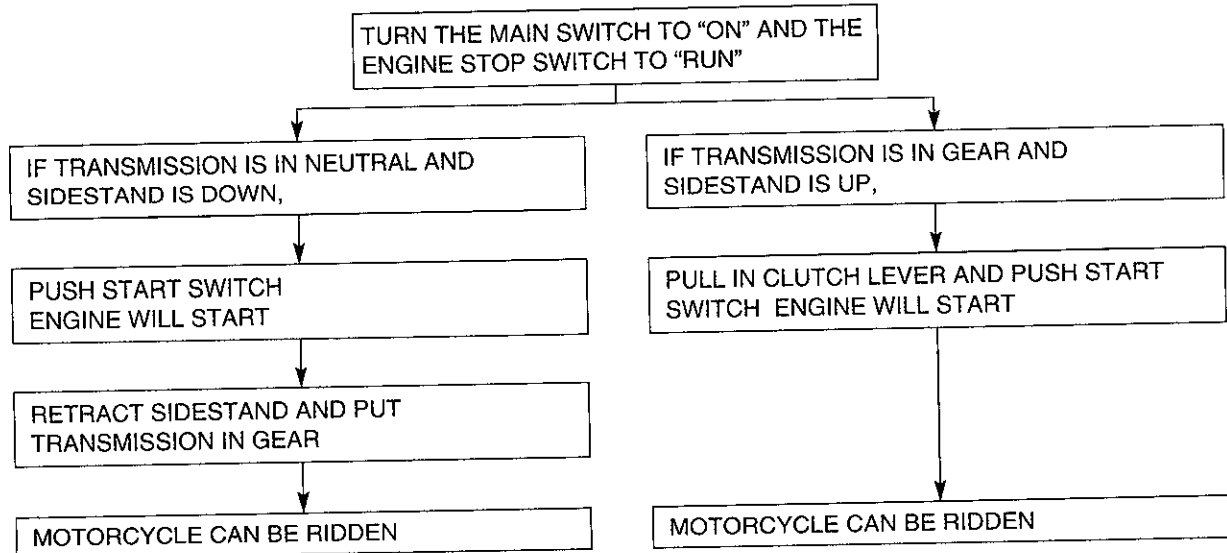

OPERATION AND IMPORTANT RIDING POINTS

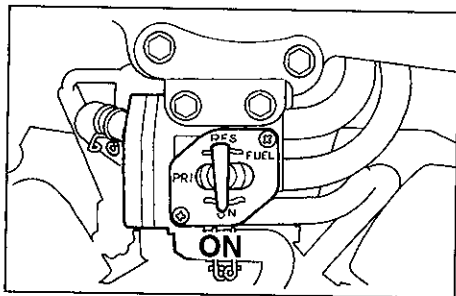

1. Turn the fuel cock to "ON"
2. Turn the main switch to "ON" and the engine stop switch to "RUN".
3. Shift transmission into neutral

EUU03001

NOTE:

When the transmission is in neutral, the neutral indicator light should be on. If the light does not come on, ask a Yamaha dealer to inspect it.

4. Turn on the starter (choke) and completely close the throttle grip
5. Start the engine by pushing the start switch

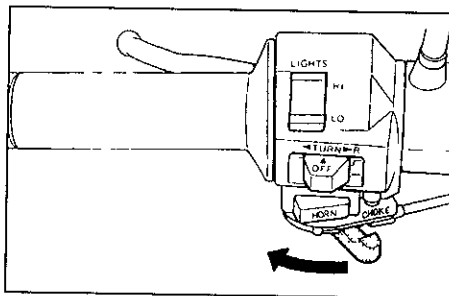

EUU02501

NOTE:

If the engine fails to start, release the start switch, wait a few seconds, then try again. Each attempt should be as short as possible to preserve the battery. Do not crank the engine more than 10 seconds on any one attempt.

6. After starting the engine, move the starter to the halfway position.

EUU02600

NOTE:

For maximum engine life, always warm up the engine before starting off. Never accelerate hard with a cold engine.

7. After warming up the engine, turn off the starter completely.

EUU02701

NOTE:

The engine is warm when it responds normally to the throttle with the starter (choke) turned off.

OPERATION AND IMPORTANT RIDING POINTS

EAJ10802

Starting a warm engine

The starter (choke) is not required when the engine is warm

EUU31401

CAUTION

See the "Engine break-in" section prior to operating the motorcycle for the first time.

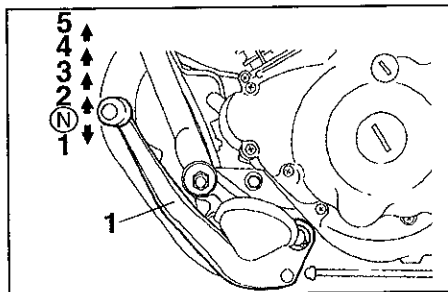

1 Shift pedal
N Neutral

EAJ20004

Shifting

The transmission lets you control the amount of power you have available at a given speed for starting, accelerating, climbing hills, etc. The use of the shift pedal is shown in the illustration.

To shift into neutral, depress the shift pedal repeatedly until it reaches the end of its travel, then raise the pedal slightly.

EUU31501

CAUTION

1. Do not coast for long periods with the engine off, and do not tow the motorcycle a long distance. Even with gears in neutral, the transmission is only properly lubricated when the engine is running. Inadequate lubrication may damage the transmission.
2. Always use the clutch when changing gears. The engine, transmission, and driveline are not designed to withstand the shock of forced shifting and can be damaged by shifting without using the clutch.

OPERATION AND IMPORTANT RIDING POINTS

EAF00100*

Tips for reducing fuel consumption

Your motorcycle's fuel consumption depends to a large extent on your riding style. The following tips can help reduce fuel consumption:

1. Warm up the engine before riding
2. Turn off the starter (choke) as soon as possible.
3. Shift up swiftly and avoid high engine speeds during acceleration
4. Do not double-clutch or rev the engine while shifting down and avoid high engine speeds with no load on the engine
5. Turn off the engine instead of letting it idle for an extended length of time, i.e. in traffic jams, at traffic lights or railroad crossings

EAF30000

Engine break-in

There is never a more important period in the life of your motorcycle than the period between zero and 1,000 km. For this reason we ask that you carefully read the following material. Because the engine is brand new, you must not put an excessive load on it for the first 1,000 km. The various parts in the engine wear and polish themselves to the correct operating clearances. During this period, prolonged full throttle operation, or any condition which might result in excessive heating of the engine, must be avoided.

EAF33001

- 1 0 ~ 150 km:
Avoid operation above 1/3 throttle. Stop the engine and let it cool for 5 to 10 minutes after every hour of operation. Vary the speed of the motorcycle from time to time. Do not operate it at one set throttle position.
- 2 150 ~ 500 km.
Avoid prolonged operation above 1/2 throttle. Rev the motorcycle freely through the gears, but do not use full throttle at any time.
- 3 500 ~ 1,000 km
Avoid cruising speeds in excess of 3/4 throttle.
4. 1,000 km and beyond:
Avoid prolonged full throttle operation. Vary speeds occasionally.

OPERATION AND IMPORTANT RIDING POINTS

EUU37201

EAF40001

CAUTION

- After 1,000 km of operation, be sure to replace the engine oil and oil filter, and clean the oil strainer.
 - If any engine trouble should occur during the break-in period, consult a Yamaha dealer immediately.
-

Parking

When parking the motorcycle, stop the engine and remove the ignition key.

EUU63001

WARNING

The exhaust system is hot. Park the motorcycle in a place where pedestrians or children are not likely to touch the motorcycle. Do not park the motorcycle on a slope or soft ground; the motorcycle may overturn.

EAH00400

Periodic inspection, adjustment and lubrication will keep your motorcycle in the safest and most efficient condition possible. Safety is an obligation of the motorcycle owner. The maintenance and lubrication schedule chart should be considered strictly as a guide to general maintenance and lubrication intervals. **YOU MUST TAKE INTO CONSIDERATION THAT WEATHER, TERRAIN, GEOGRAPHICAL LOCATIONS, AND A VARIETY OF INDIVIDUAL USES ALL TEND TO DEMAND THAT EACH OWNER ALTER THIS TIME SCHEDULE TO SHORTER INTERVALS TO MATCH THE ENVIRONMENT.** The most important points of motorcycle inspection, adjustment, and lubrication are explained in the following pages.

EUU63200

⚠ WARNING

If you are not familiar with motorcycle service, this work should be done by a Yamaha dealer.

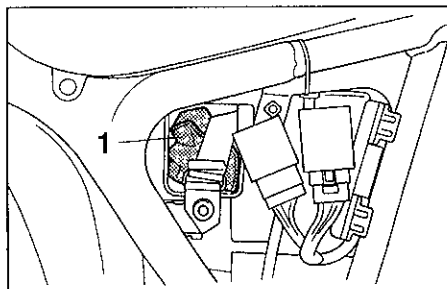

1 Tool kit

EAH10300

Tool kit

The service information included in this manual is intended to provide you, the owner, with the necessary information for completing some of your own preventive maintenance and minor repairs. The tools provided in the owner's tool kit are to assist you in the performance of periodic maintenance. However, some other tools such as a torque wrench are also necessary to perform the maintenance correctly.

EUU18500

NOTE:

If you do not have necessary tools required during a service operation, take your motorcycle to a Yamaha dealer for service.

EUU67100

⚠ WARNING

Modifications to this motorcycle not approved by Yamaha may cause loss of performance, and render it unsafe for use. Consult a Yamaha dealer before attempting any changes.

PERIODIC MAINTENANCE AND MINOR REPAIR

EAH01601

PERIODIC MAINTENANCE AND LUBRICATION

NO.	ITEM	CHECKS AND MAINTENANCE JOBS	After break-in (1,000 km)	EVERY	
				6,000 km or 6 months (whichever comes first)	12,000 km or 12 months (whichever comes first)
1	* Fuel line	<ul style="list-style-type: none"> • Check fuel hoses and vacuum hose for cracks or damage • Replace if necessary 		√	√
2	* Fuel filter	<ul style="list-style-type: none"> • Check condition • Replace if necessary 			√
3	Spark plugs	<ul style="list-style-type: none"> • Check condition • Clean, regap or replace if necessary 	√	√	√
4	* Valves	<ul style="list-style-type: none"> • Check valve clearance • Adjust if necessary 	√	√	√
5	Air filter	<ul style="list-style-type: none"> • Clean or replace if necessary 		√	√
6	* Battery	<ul style="list-style-type: none"> • Check electrolyte level and specific gravity • Correct or recharge if necessary • Make sure that the breather hose is properly routed 		√	√
7	Clutch	<ul style="list-style-type: none"> • Check operation • Adjust or replace cable 		√	√
8	* Front brake	<ul style="list-style-type: none"> • Check operation, fluid level and vehicle for fluid leakage (See NOTE on page 6-4) • Correct accordingly • Replace brake pads if necessary 		√	√
9	* Rear brake	<ul style="list-style-type: none"> • Check operation • Adjust cable and replace brake shoes if necessary 		√	√
10	* Wheels	<ul style="list-style-type: none"> • Check balance, runout, spoke tightness and for damage • Tighten spokes and rebalance, replace if necessary 		√	√

6

PERIODIC MAINTENANCE AND MINOR REPAIR

NO.	ITEM	CHECKS AND MAINTENANCE JOBS	After break-in (1,000 km)	EVERY	
				6,000 km or 6 months (whichever comes first)	12,000 km or 12 months (whichever comes first)
11	* Tires	<ul style="list-style-type: none"> • Check tread depth and for damage • Replace if necessary • Check air pressure • Correct if necessary 		√	√
12	* Wheel bearings	<ul style="list-style-type: none"> • Check bearing for looseness or damage • Replace if necessary 		√	√
13	* Swingarm	<ul style="list-style-type: none"> • Check swingarm pivoting point for play • Correct if necessary • Lubricate with molybdenum disulfide grease every 24,000 km or 24 months (whichever comes first) 	√	√	√
14	Drive chain	<ul style="list-style-type: none"> • Check chain slack • Adjust if necessary Make sure that the rear wheel is properly aligned • Clean and lubricate 	Every 1,000 km and after washing the motorcycle or riding in the rain		
15	* Steering bearings	<ul style="list-style-type: none"> • Check bearing play and steering for roughness • Correct accordingly • Lubricate with lithium soap base grease every 24,000 km or 24 months (whichever comes first) 	√		√
16	* Chassis fasteners	<ul style="list-style-type: none"> • Make sure that all nuts, bolts and screws are properly tightened • Tighten if necessary 	√	√	√
17	Sidestand	<ul style="list-style-type: none"> • Check operation • Lubricate and repair if necessary 	√	√	√
18	× Sidestand switch	<ul style="list-style-type: none"> • Check operation • Replace if necessary 	√	√	√
19	* Front fork	<ul style="list-style-type: none"> • Check operation and for oil leakage • Correct accordingly 		√	√
20	* Rear shock absorber assemblies	<ul style="list-style-type: none"> • Check operation and shock absorbers for oil leakage • Replace shock absorber assembly if necessary 		√	√

PERIODIC MAINTENANCE AND MINOR REPAIR

NO	ITEM	CHECKS AND MAINTENANCE JOBS	After break-in (1,000 km)	EVERY	
				6,000 km or 6 months (whichever comes first)	12,000 km or 12 months (whichever comes first)
21	* Carburetor	<ul style="list-style-type: none"> • Check engine idling speed and starter operation • Adjust if necessary 	√	√	√
22	Engine oil	<ul style="list-style-type: none"> • Check oil level and vehicle for oil leakage • Correct if necessary • Change (Warm engine before draining) 	√	√	√
23	Engine oil filter element	<ul style="list-style-type: none"> • Replace 	√		√
24	Engine oil strainer	<ul style="list-style-type: none"> • Clean or replace if necessary 	√	√	√

* Since these items require special tools, data and technical skills, they should be serviced by a Yamaha dealer

EUU21500

NOTE:

- The air filter needs more frequent service if you are riding in unusually wet or dusty areas
- Brake fluid replacement
 - 1 When disassembling the master cylinder or caliper cylinder, always replace the brake fluid. Check the brake fluid level regularly and fill as required
 - 2 Replace the oil seals on the inner parts of the master cylinder and caliper cylinder every two years
 - 3 Replace the brake hoses every four years or if cracked or damaged.

PERIODIC MAINTENANCE AND MINOR REPAIR

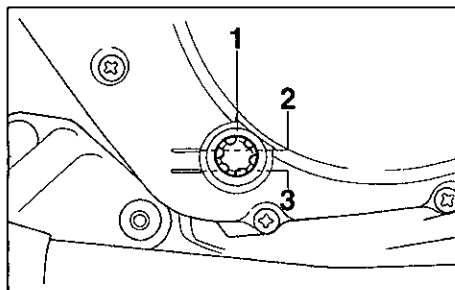

- 1 Level window
- 2 Maximum level mark
- 3 Minimum level mark

EAH44706*

Engine oil

6

1 Oil level inspection

- a. Place the motorcycle on a level place and hold it in an upright position. Warm up the engine for several minutes

EUU03901

NOTE:

Be sure the motorcycle is positioned straight up when checking the oil level. A slight tilt toward the side can result in false readings

- b. With the engine stopped, check the oil level through the level window located at the lower part of the right side crankcase cover

EUU04000

NOTE:

Wait a few minutes until the oil level settles before checking.

- c. The oil level should be between maximum level and minimum level marks. If the level is low, fill engine with sufficient oil to raise it to the specified level

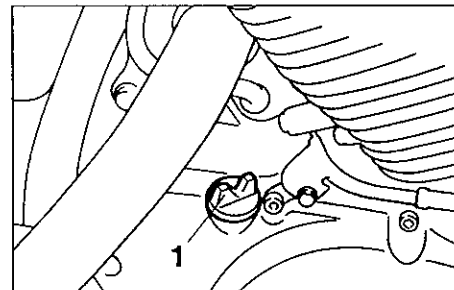

- 1 Engine oil filler cap
- 2 Engine oil and oil filter element replacement
 - a. Warm up the engine for a few minutes.
 - b. Stop the engine. Place an oil pan under the engine and remove the oil filler cap

PERIODIC MAINTENANCE AND MINOR REPAIR

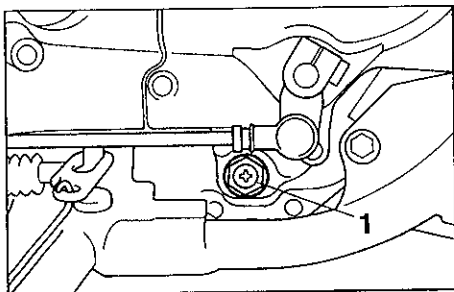

1 Engine oil drain plug

c. Remove the drain plug and drain the oil.

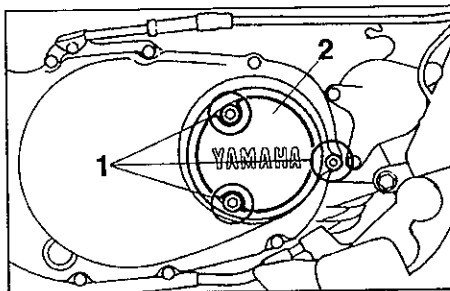

1 Oil filter cover bolt (× 3)

2 Oil filter cover

- d. Remove the oil filter cover bolts and the oil filter cover.
e. Remove the oil filter and O-ring.
f. Reinstall the drain plug and tighten it to the specified torque.

Tightening torque:
Drain plug:
34 Nm (3.4 m·kg)

- g. Install the new oil filter, new O-ring and the oil filter cover. Tighten the oil filter cover bolts to the specified torque

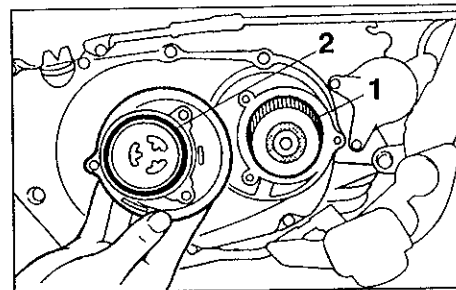

1 Oil filter

2 O-ring

Tightening torque:
Oil filter cover bolt
7 Nm (0.7 m·kg)

NOTE:
Make sure the O-ring is seated properly

- h. Fill the engine with oil. Install the oil filler cap and tighten it

EUU04101

PERIODIC MAINTENANCE AND MINOR REPAIR

Recommended oil:

See page 8-1.

Oil quantity

Total amount.

1 8 L

Periodic oil change:

1 4 L

With oil filter replacement:

1 6 L

EUU32401

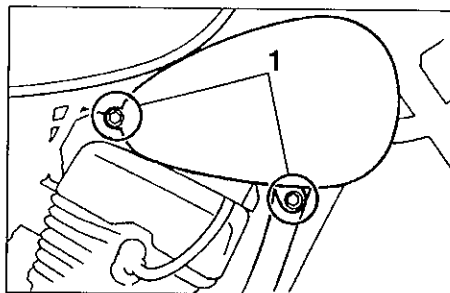

1 Bolt (x 2)

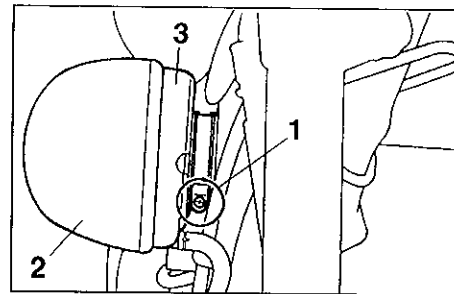

1 Bolt
2 Air filter cover
3 Air filter case

EAH64008

Air filter

The air filter should be cleaned at the specified intervals. It should be cleaned more frequently if you are riding in unusually wet or dusty areas

- 1 Remove the bolts and the air filter case

CAUTION:

- Do not put in any chemical additives. Engine oil also lubricates the clutch and additives could cause clutch slippage.
- Be sure no foreign material enters the crankcase.

- i Start the engine and warm up for a few minutes. While warming up, check for oil leakage. If oil leakage is found, stop the engine immediately and check for the cause.
- j Stop the engine and check the oil level

PERIODIC MAINTENANCE AND MINOR REPAIR

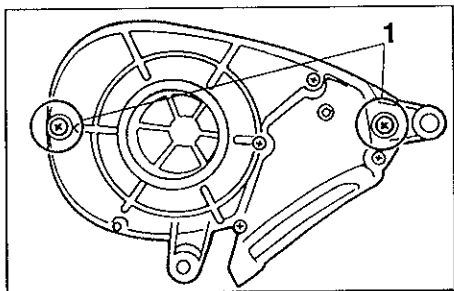

- 1 Screw (x 2)
- 2 Remove the screws and the air filter cover

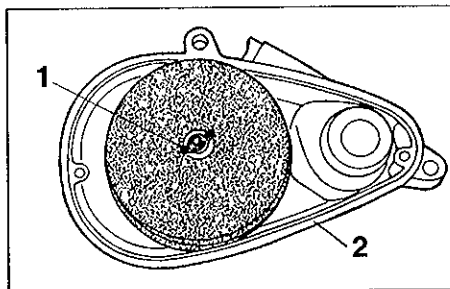

- 1 Wing nut
- 2 Air filter case
3. Remove the wing nut and the air filter

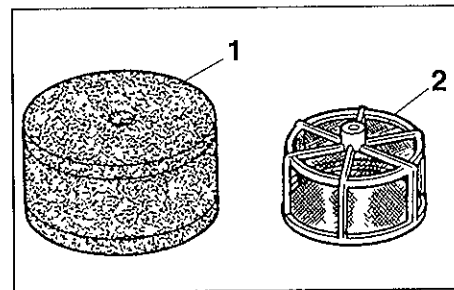

- 1 Foam element
- 2 Frame
- 4 Remove the foam element from its frame and clean it with solvent. After cleaning, remove the remaining solvent by squeezing it.
- 5 Apply recommended oil to the entire surface of the element and squeeze out the excess oil. It should be wet but not dripping.

Recommended oil
Same as engine oil

6. Pull the element over its frame, install the air filter in the case and tighten the wing nut

PERIODIC MAINTENANCE AND MINOR REPAIR

7. Install the air filter cover and air filter case

EUU42403

CAUTION:

- Make sure the air filter is properly seated in the air filter case.
- The engine should never be run without the air filter installed. Excessive piston and/or cylinder wear may result.

Carburetor adjustment

EAH90001

The carburetor is a vital part of the engine and requires very sophisticated adjustment. Most adjustments should be left to a Yamaha dealer who has the professional knowledge and experience to do so. However, the following may be serviced by the owner as part of routine maintenance.

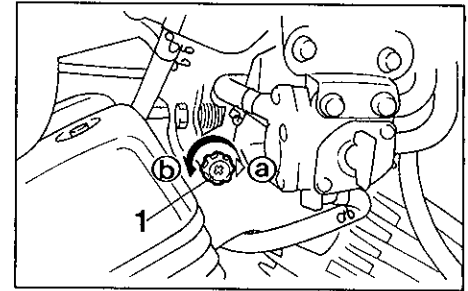

- 1 Throttle stop screw

EUU33001

CAUTION:

The carburetor was set at the Yamaha factory after many tests. If the settings are changed, poor engine performance and damage may result.

EAH92002

Idle speed adjustment

EUU13700

NOTE:

A diagnostic tachometer must be used for this procedure.

- 1 Attach the tachometer. Start the engine and warm it up for a few minutes at approximately 1,000 to 2,000 r/min. Occasionally rev the engine to 4,000 to 5,000 r/min. The engine is warm when it quickly responds to the throttle.

PERIODIC MAINTENANCE AND MINOR REPAIR

EAH90801

2. Set the idle to the specified engine speed by adjusting the throttle stop screw. Turn the screw in direction ① to increase engine speed and in direction ② to decrease engine speed.

Standard idle speed:
1,250 ~ 1,350 r/min

EUU04500

NOTE:

If the specified idle speed cannot be obtained by performing the above adjustment, consult a Yamaha dealer.

Valve clearance adjustment

The correct valve clearance changes with use, resulting in improper fuel/air supply or engine noise. To prevent this, the valve clearance must be adjusted regularly. This adjustment however, should be left to a professional Yamaha service technician.

PERIODIC MAINTENANCE AND MINOR REPAIR

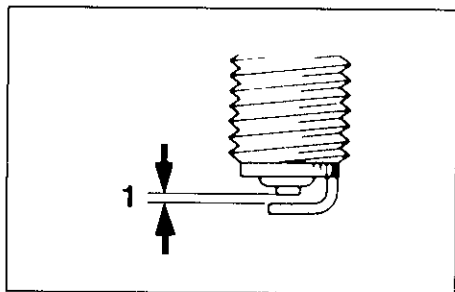

1 Spark plug gap

EAH20102

Spark plug inspection

The spark plug is an important engine component and is easy to inspect. The condition of the spark plug can indicate the condition of the engine.

Normally, all spark plugs from the same engine should have the same color on the white insulator around the center electrode. The ideal color at this point is a medium-to-light tan color for a motorcycle that is being ridden normally. If one spark plug shows a distinctly different color, there could be something wrong with the engine.

Do not attempt to diagnose such problems yourself. Instead, take the motorcycle to a Yamaha dealer. You should periodically remove and inspect the spark plugs because heat and deposits will cause any spark plug to slowly break down and erode. If electrode erosion becomes excessive, or if carbon and other deposits are excessive, you should replace the spark plug with the specified plug.

Specified spark plug:
C6HSA (NGK) or
U20FS-U (DENSO)

Before installing any spark plug, measure the electrode gap with a wire thickness gauge. Adjust the gap to specification.

Spark plug gap
0.6 ~ 0.7 mm

When installing the spark plug, always clean the gasket surface and use a new gasket. Wipe off any grime from the threads and tighten the spark plug to the specified torque.

Tightening torque
Spark plug
12.5 Nm (1.25 m·kg)

EUJ003802

NOTE:

If a torque wrench is not available when you are installing a spark plug, a good estimate of the correct torque is 1/4 to 1/2 turn past finger tight. Have the spark plug tightened to the specified torque as soon as possible.

PERIODIC MAINTENANCE AND MINOR REPAIR

EUU67500

EUU67701

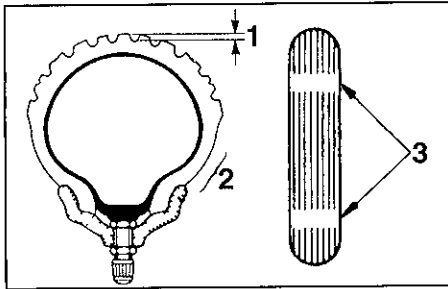

- 1 Tread depth
- 2 Side wall
- 3 Wear indicator

EAE97900

Tires

To ensure maximum performance, long service and safe operation, note the following.

1. Tire air pressure

Always check and adjust the tire pressure before operating the motorcycle.

⚠ WARNING

Tire inflation pressure should be checked and adjusted when the temperature of the tire equals the ambient air temperature. Tire inflation pressure must be adjusted according to total weight of cargo, rider, passenger, and accessories (fairing, saddlebags, etc. if approved for this model), and vehicle speed.

Maximum load*	183 kg	
Cold tire pressure	Front	Rear
Up to 90 kg	175 kPa (1.75 kg/cm ² , 1.75 bar)	200 kPa (2.00 kg/cm ² , 2.00 bar)
90 kg load ~ Maximum load*	200 kPa (2.00 kg/cm ² , 2.00 bar)	225 kPa (2.25 kg/cm ² , 2.25 bar)

* Load is the total weight of cargo, rider, passenger and accessories

⚠ WARNING

Proper loading of your motorcycle is important for several characteristics of your motorcycle, such as handling, braking, performance and safety. Do not carry loosely packed items that can shift. Securely pack your heaviest items close to the center of the motorcycle, and distribute the weight evenly from side to side. Properly adjust the suspension for your load, and check the condition and pressure of your tires. **NEVER OVERLOAD YOUR MOTORCYCLE.** Make sure the total weight of the cargo, rider, passenger, and accessories (fairing, saddlebags, etc. if approved for this model) does not exceed the maximum load of the motorcycle. Operation of an overloaded motorcycle could cause tire damage, an accident, or even injury.

PERIODIC MAINTENANCE AND MINOR REPAIR

EUU68402

EAE93401

2 Tire inspection

Always check the tires before operating the motorcycle. If a tire tread shows crosswise lines (minimum tread depth), if the tire has a nail or glass fragments in it, or if the side wall is cracked, contact a Yamaha dealer immediately and have the tire replaced.

FRONT

Manufacturer	Size	Type
CHENG SHIN	3 00-18 47P	C-916

REAR

Manufacturer	Size	Type
CHENG SHIN	130/90-15M/C 66P	C-915

Minimum tire tread depth (front and rear)	1 0 mm
---	--------

EUU12600

NOTE:

These limits may be different by regulation from country to country. If so, conform to the limits specified by the regulations of your own country.

WARNING

1. It is dangerous to ride with a worn-out tire. When a tire tread begins to show lines, have a Yamaha dealer replace the tire immediately. Brakes, tires, and related wheel parts replacement should also be left to a Yamaha dealer.
2. Patching a punctured tube is not recommended. If it is absolutely necessary to do so, use great care and replace the tube as soon as possible with a good quality replacement.

Wheels

To ensure maximum performance, long service, and safe operation, note the following.

- 1 Always inspect the wheels before a ride. Check for cracks, bends or warpage of the wheel. Be sure the spokes are tight and undamaged. If any abnormal condition exists in a wheel, consult a Yamaha dealer. Do not attempt even small repairs to the wheel. If a wheel is deformed or cracked, it must be replaced.
- 2 Tires and wheels should be balanced whenever either one is changed or replaced. Failure to have a wheel balanced can result in poor performance, adverse handling characteristics, and shortened tire life.
- 3 Ride at moderate speeds after changing a tire since the tire surface must first be broken in for it to develop its optimal characteristics.

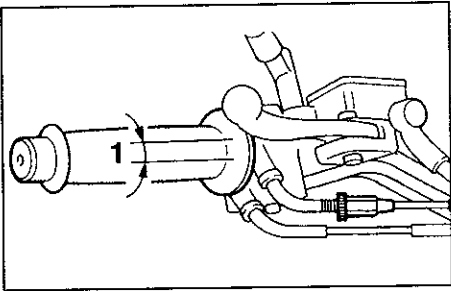

1 Free play

EAH92202

Throttle cable free play inspection

There should be a free play of 3 ~ 5 mm at the throttle grip. If the free play is incorrect, ask a Yamaha dealer to make this adjustment.

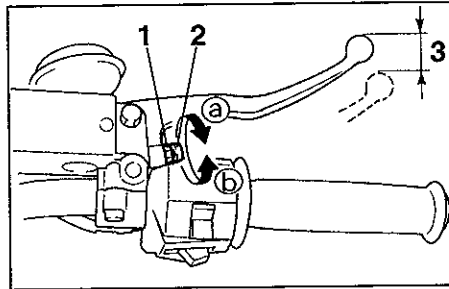

1 Locknut

2 Adjusting bolt

3 Free play

EAH80104

Front brake lever free play adjustment

The free play at the front brake lever should be 2 ~ 5 mm.

- 1 Loosen the locknut
- 2 Turn the adjusting bolt in direction **(a)** to increase free play or in direction **(b)** to decrease free play.
- 3 After adjusting, tighten the locknut.

! WARNING

- Check the brake lever free play. Be sure the brake is working properly.
- A soft or spongy feeling in the brake lever can indicate the presence of air in the brake system. This air must be removed by bleeding the brake system before the motorcycle is operated. Air in the system will cause greatly diminished braking capability and can result in loss of control and an accident. Have a Yamaha dealer inspect and bleed the system if necessary.

PERIODIC MAINTENANCE AND MINOR REPAIR

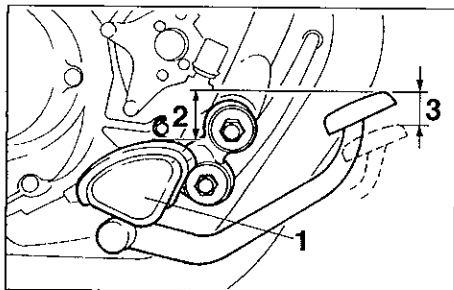

- 1 Footrest
- 2 Pedal height
- 3 Free play

EAH87106

Rear brake pedal height and free play adjustment

EUU64301

⚠ WARNING

It is advisable to have a Yamaha dealer make this adjustment.

- 1 Pedal height
The brake pedal should be positioned so that its top end is approximately 60 mm above the top of the footrest

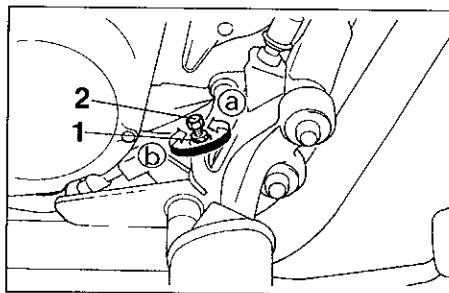

- 1 Locknut
- 2 Adjusting bolt

- a Loosen the locknut
- b Turn the adjusting bolt in direction (a) to raise pedal height or in direction (b) to lower pedal height.
- c Tighten the locknut

EUU64400

⚠ WARNING

After adjusting the pedal height adjust brake pedal free play.

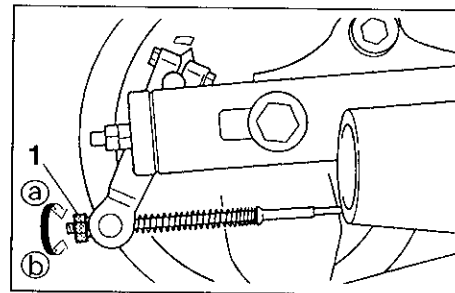

- 1 Adjusting nut

2 Free play

The rear brake pedal free play should be adjusted to 20 ~ 30 mm at the brake pedal end. Turn the adjusting nut on the brake rod in direction (a) to increase free play or in direction (b) to decrease free play.

PERIODIC MAINTENANCE AND MINOR REPAIR

EUU82700

⚠ WARNING

- Brake pedal free play should be checked whenever the chain is adjusted or the rear wheel is removed and then reinstalled.
- Check the operation of the brake light after adjusting the rear brake.
- If it is impossible to make proper adjustment, consult a Yamaha dealer.

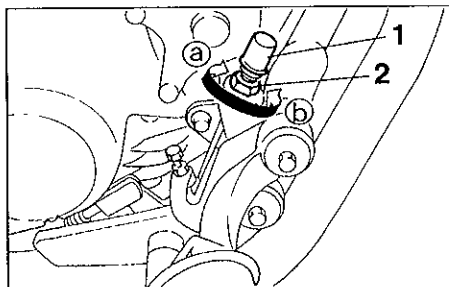

- 1 Main body
2 Adjusting nut

EAH83302

Brake light switch adjustment

The rear brake light switch is activated by the brake pedal and is properly adjusted when the brake light comes on just before braking takes effect. To adjust the rear brake light switch, hold the switch body so it does not rotate while turning the adjusting nut. Turn the adjusting nut in direction (a) to make the brake light come on earlier. Turn the adjusting nut in direction (b) to make the brake light come on later.

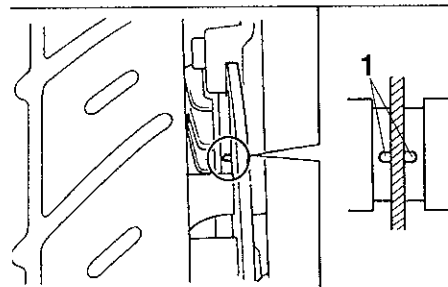

- 1 Wear indicator groove

EAH81402

Checking the front brake pads and rear brake shoes

EAH817A0

FRONT

A wear indicator groove is provided on each brake pad. This indicator allows checking of brake pad wear without disassembling the brake. Inspect the groove. If the groove has almost disappeared, ask a Yamaha dealer to replace the pads.

PERIODIC MAINTENANCE AND MINOR REPAIR

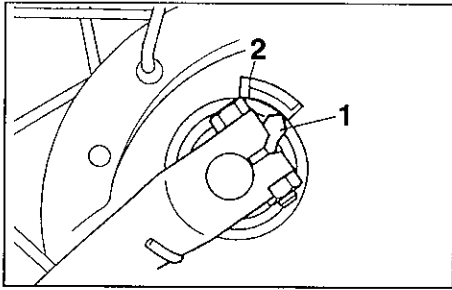

- 1 Wear indicator
- 2 Wear limit line

EAH82601

REAR

Apply the brake and inspect the wear indicator

If the indicator reaches the wear limit line, ask a Yamaha dealer to replace the shoes.

6

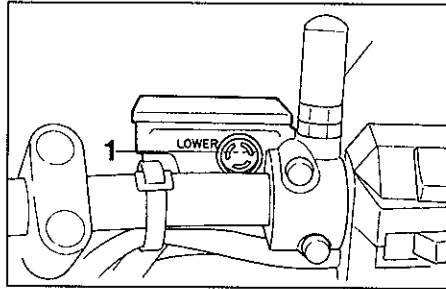

- 1 Minimum level mark

EAH88203

Inspecting the brake fluid level

Insufficient brake fluid may let air enter the brake system, possibly causing the brakes to become ineffective.

Before riding, check that the brake fluid is above the minimum level and fill when necessary.

Observe these precautions:

- 1 When checking the fluid level, make sure the top of the master cylinder is level by turning the handlebars.

- 2 Use only the designated quality brake fluid. Otherwise, the rubber seals may deteriorate, causing leakage and poor brake performance.

Recommended brake fluid: DOT 4

EUU13100

NOTE:

If DOT 4 is not available, DOT 3 can be used

3. Refill with the same type of brake fluid. Mixing fluids may result in a harmful chemical reaction and lead to poor brake performance.
4. Be careful that water does not enter the master cylinder when refilling. Water will significantly lower the boiling point of the fluid and may result in vapor lock.
5. Brake fluid may deteriorate painted surfaces or plastic parts. Always clean up spilled fluid immediately.
6. Have a Yamaha dealer check the cause if the brake fluid level goes down

PERIODIC MAINTENANCE AND MINOR REPAIR

Brake fluid replacement

EAH83502

The brake fluid should be replaced only by trained Yamaha service personnel. Have the Yamaha dealer replace the following components during periodic maintenance or when they are damaged or leaking:

- a. oil seals (every two years)
- b. brake hoses (every four years)

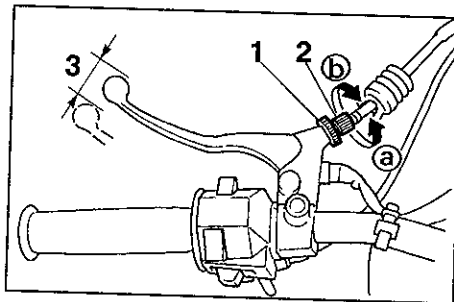

- 1 Locknut
- 2 Adjusting bolt
- 3 Free play

Clutch lever free play adjustment

EA100505

The clutch lever free play should be adjusted to 10 ~ 15 mm.

1. Loosen the locknut at the clutch lever
2. Turn the adjusting bolt at the clutch lever in direction (a) to increase free play or in direction (b) to decrease free play.
3. Tighten the locknut at the clutch lever.

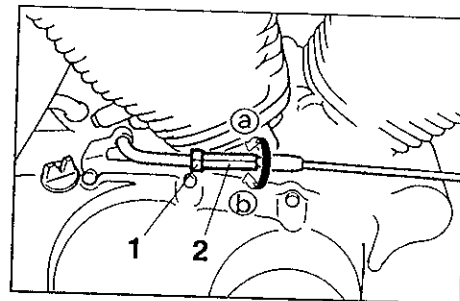

- 1 Locknut
- 2 Adjusting nut

If the specified free play cannot be obtained, proceed with the following steps.

4. Loosen the locknut at the clutch lever
5. Turn the adjusting bolt at the clutch lever in direction (a) to loosen the cable
6. Loosen the locknut at the crankcase side.
7. Turn the adjusting nut at the crankcase in direction (a) to increase free play or in direction (b) to decrease free play.
8. Tighten the locknut at the crankcase and the clutch lever

PERIODIC MAINTENANCE AND MINOR REPAIR

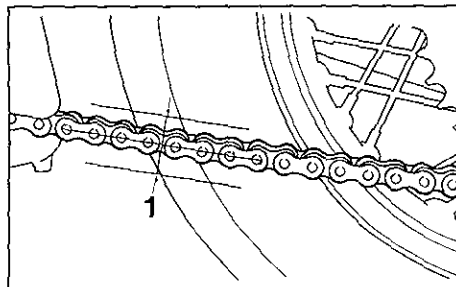

1 Chain slack

EAI40601

Drive chain slack check

EUU04801

NOTE:

Spin the wheel several times and find the tightest position of the chain. Check and/or adjust the chain slack while it's in this tightest position.

To check the chain slack the motorcycle must be held straight up with both wheels on the ground and without rider. Check the slack at the position shown in the illustration. Normal slack is approximately 30 ~ 40 mm. If the slack exceeds 40 mm, adjust.

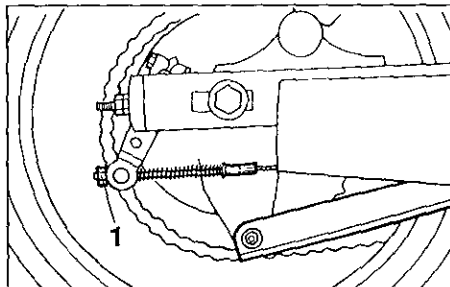

1 Adjusting nut

EAI44000

Drive chain slack adjustment

- 1 Loosen the rear brake pedal free play adjusting nut.

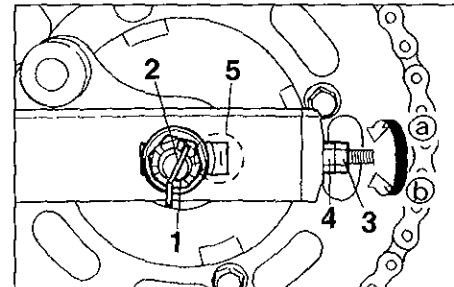

- 1 Axle nut
- 2 Cotter pin
- 3 Locknut
- 4 Adjusting nut
- 5 Alignment marks

2. Remove the cotter pin from the axle nut.
3. Loosen the axle nut.
4. Loosen the chain adjusting locknuts on each chain puller. To tighten the chain, turn the chain adjusting nuts in direction (a). To loosen the chain, turn the chain adjusting nuts in direction (b) and push the wheel forward. Turn each chain adjusting nut exactly the same amount to maintain correct axle alignment. There are marks

PERIODIC MAINTENANCE AND MINOR REPAIR

EUU64500

on each side of the swingarm. Use these marks to align the rear wheel.

EUU33301

CAUTION

Too little chain slack will overload the engine and other vital parts. Keep the slack within the specified limits.

- 5 After adjusting, be sure to tighten each chain adjusting locknut. Then tighten the axle nut to the specified torque.

Tightening torque
Axle nut
105 Nm (10.5 m·kg)

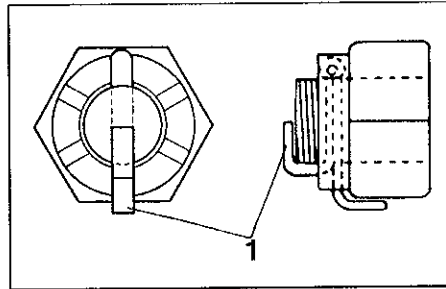

1 Cotter pin

- 6 Insert a new cotter pin into the axle nut and bend the end of the cotter pin as shown. If the notch in the axle nut and the cotter pin hole do not match, tighten the nut slightly to align them.

EUU64700

WARNING

Always use a new cotter pin on the axle nut.

- 7 Adjust the free play in the brake pedal.

WARNING

Check the operation of the brake light after adjusting the rear brake.

PERIODIC MAINTENANCE AND MINOR REPAIR

Drive chain lubrication

EAI40702

The chain consists of many parts which work with each other. If the chain is not maintained properly, it will wear out quickly. Therefore, the chain must be serviced regularly. This service is especially necessary when riding in dusty areas. This motorcycle is equipped with a sealed type chain. Steam cleaning, high-pressure washes, and solvents can damage chain so do not use these for cleaning it. Use only kerosene to clean the drive chain. Wipe it dry, and thoroughly lubricate it with engine oil. Do not use any other lubricants on the drive chain. They may contain solvents that could damage the sealed chain.

EUU48300

CAUTION

Be sure to oil the chain after washing the motorcycle or riding in the rain.

Cable inspection and lubrication

EAI10703

EUU64602

⚠ WARNING

Damage to the outer housing of cables may lead to internal rusting and interfere with the cable movement. Replace damaged cables as soon as possible to prevent unsafe conditions.

Lubricate the cables and cable ends. If a cable does not operate smoothly, ask a Yamaha dealer to replace it.

Recommended lubricant
Same as engine oil

Throttle cable and grip lubrication

EAI10201

The throttle twist grip assembly should be greased at the time that the cable is lubricated, since the grip must be removed to get at the end of the throttle cable. After removing the screws, hold the end of the cable up in the air and put in several drops of lubricant. With the throttle grip disassembled, coat the metal surface of the grip assembly with a suitable all-purpose grease.

PERIODIC MAINTENANCE AND MINOR REPAIR

Brake and shift pedal lubrication

EAI30604

Lubricate the pivoting parts.

Recommended lubricant.
Same as engine oil

Brake and clutch lever lubrication

EAI30703

Lubricate the pivoting parts.

Recommended lubricant.
Same as engine oil

Sidestand lubrication

EAI31106

Lubricate the sidestand pivoting point and metal-to-metal contact surfaces. Check that the sidestand moves up and down smoothly.

Recommended lubricant
Same as engine oil

EUU70401

WARNING

If the sidestand does not move smoothly, consult a Yamaha dealer.

PERIODIC MAINTENANCE AND MINOR REPAIR

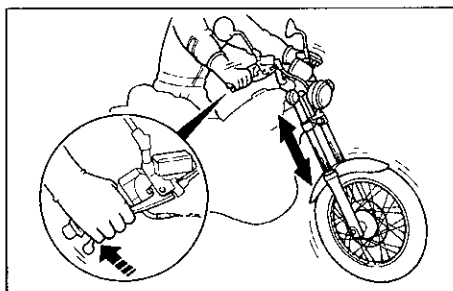

EAI20502

Front fork inspection

EUU65700

! WARNING

Securely support the motorcycle so there is no danger of it falling over.

6

- 1 Visual check
Check for scratches or damage on the inner tube and excessive oil leakage from the front fork
- 2 Operation check
Place the motorcycle on a level place.

- a Hold the motorcycle in an upright position and apply the front brake
- b Push down hard on the handlebars several times and check if the fork rebounds smoothly

EUU42500

CAUTION:

If any damage or unsmooth movement is found with the front fork, consult a Yamaha dealer.

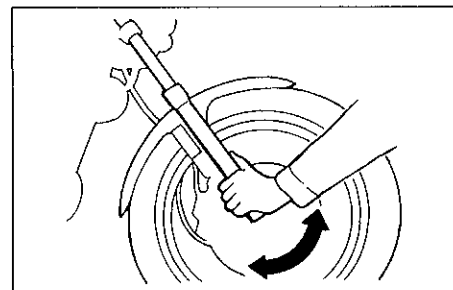

EAI60301

Steering inspection

Periodically inspect the condition of the steering. Worn out or loose steering bearings may be dangerous. Place a stand under the engine to raise the front wheel off the ground. Hold the lower end of the front forks and try to move them forward and backward. If any free play can be felt, ask a Yamaha dealer to inspect and adjust the steering. Inspection is easier if the front wheel is removed.

EUU65700

! WARNING

Securely support the motorcycle so there is no danger of it falling over.

PERIODIC MAINTENANCE AND MINOR REPAIR

EAI60103

Wheel bearings

If there is play in the front or rear wheel hub or if the wheel does not turn smoothly, have a Yamaha dealer inspect the wheel bearings. The wheel bearings should be inspected according to the General Maintenance Schedule

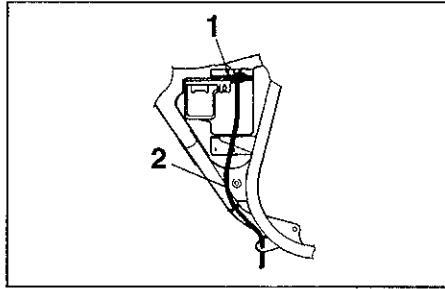

- 1 Battery
- 2 Battery breather hose

EAI70005

Battery

Check the level of the battery electrolyte and make sure that the terminals are tight. Fill with distilled water if the electrolyte level is low

EUU33602

CAUTION:

When inspecting the battery, be sure the breather hose is routed correctly. If the breather hose is positioned in such a way as to cause battery electrolyte or gas to exit onto the frame, structural and cosmetic damage to the motorcycle can occur.

PERIODIC MAINTENANCE AND MINOR REPAIR

EUU65800

WARNING

Battery electrolyte is poisonous and dangerous, causing severe burns, etc. It contains sulfuric acid. Avoid contact with skin, eyes or clothing.

Antidote:

EXTERNAL: Flush with water.

INTERNAL: Drink large quantities of water or milk. Follow with milk of magnesia, beaten egg, or vegetable oil. Call a physician immediately.

EYES: Flush with water for 15 minutes and get prompt medical attention. Batteries produce explosive gases. Keep sparks, flame, cigarettes etc., away. Ventilate when charging or using in an enclosed space. Always shield your eyes when working near batteries.

KEEP OUT OF REACH OF CHILDREN.

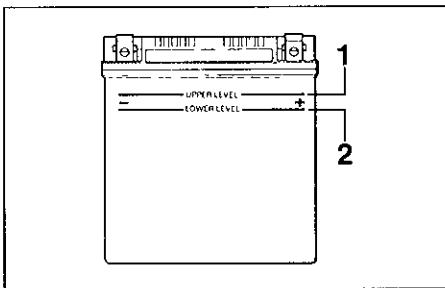

1 Maximum level mark

2 Minimum level mark

Replenishing the battery fluid

A poorly maintained battery will corrode and discharge quickly. The battery fluid should be checked at least once a month. The level should be between the minimum level and maximum level marks. Use only distilled water if refilling is necessary.

EUU33800

CAUTION:

Normal tap water contains minerals which are harmful to a battery; therefore, refill only with distilled water.

EUU65901

WARNING

Take care not to spill battery fluid on the chain. Battery fluid may weaken the chain causing shorter chain life and possibly result in an accident.

Battery storage

- 1 When the motorcycle will not be used for a month or longer, remove the battery, fully charge it and store it in a cool, dry place. Completely recharge the battery before reinstallation
2. If the battery will be stored for longer than two months, check the specific gravity of the fluid at least once a month and fully recharge the battery when it is too low.
3. Always make sure the connections are correct when putting the battery back in the motorcycle. Make sure the breather hose is properly connected and is not damaged or obstructed

PERIODIC MAINTENANCE AND MINOR REPAIR

EUU34400

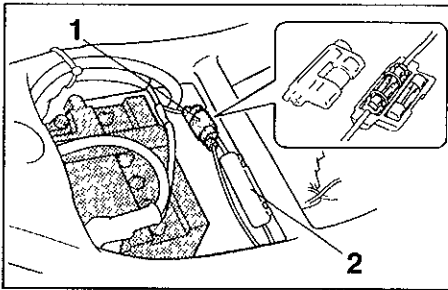

- 1 Main fuse
- 2 Signaling system fuse

EAI93403

Fuse replacement

The fuse cases are located under the rider seat

If a fuse is blown, turn off the main switch and the switch of the circuit in question. Install a new fuse of specified amperage. Turn on the switches and see if the electrical device operates. If the fuse immediately blows again, consult a Yamaha dealer.

CAUTION:

Do not use fuses of higher amperage rating than those recommended. Substitution of a fuse of improper rating can cause extensive electrical system damage and possibly a fire.

Specified fuses:

Main fuse.	20 A
Signaling system fuse:	10 A

PERIODIC MAINTENANCE AND MINOR REPAIR

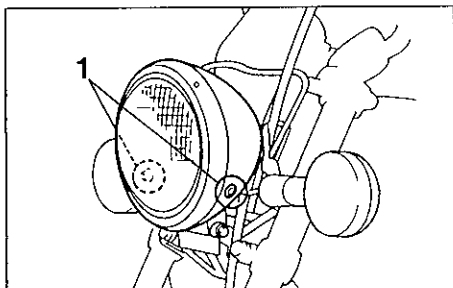

- 1 Screw (x 2)

EAI88305*

Headlight bulb replacement

This motorcycle is equipped with a quartz bulb headlight

If the headlight bulb burns out, replace the bulb as follows:

- 1 Remove the headlight unit screws

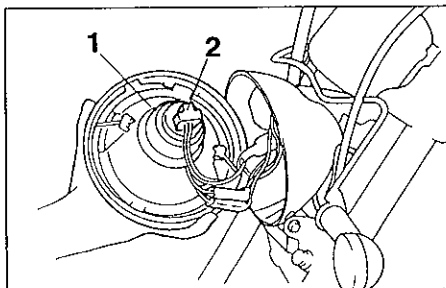

- 1 Bulb cover
 - 2 Connector
- 2 Remove the connector, the headlight unit and then the bulb cover

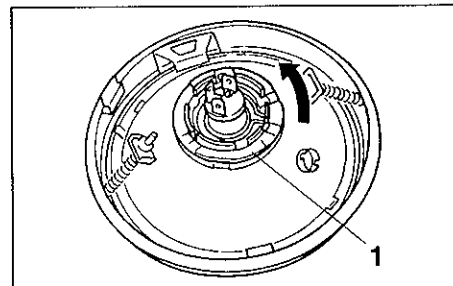

- 1 Bulb holder
3. Turn the bulb holder counterclockwise to remove it and remove the defective bulb

EUU66002

WARNING

Keep flammable products and your hands away from a bulb while it is on, as it is hot. Do not touch a bulb until it cools down.

- 4 Put a new bulb into position and secure it in place with the bulb holder

EAJ83700

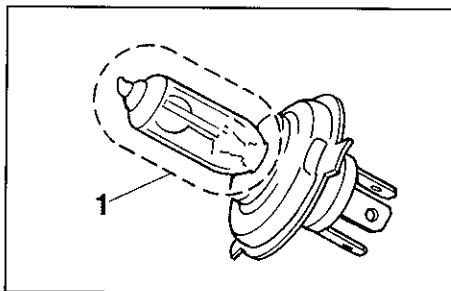

1 Don't touch

EUJ34101

CAUTION:

Avoid touching the glass part of a bulb. Keep it free from oil; otherwise, the transparency of the glass, life of the bulb, and luminous flux will be adversely affected. If oil gets on a bulb, thoroughly clean it with a cloth moistened with alcohol or lacquer thinner.

- 5 Install the bulb cover, connector and headlight unit. Ask a Yamaha dealer to adjust the headlight beam if necessary.

Supporting the motorcycle

Since the Yamaha XV250S has no centerstand, follow these precautions when removing the front and rear wheel or performing other maintenance requiring the motorcycle to stand upright.

Front wheel service.

To stabilize the rear of the motorcycle, either use a motorcycle stand or place a motorcycle jack under the frame in front of the rear wheel to prevent it from moving from side to side. Then use a motorcycle stand to elevate the front wheel off of the ground.

Rear wheel service

Use a motorcycle stand or motorcycle jack to elevate the motorcycle so the rear wheel is off the ground. Alternatively, two jacks can be placed under the frame or swingarm

Check that the motorcycle is in a stable and level position before starting any maintenance. A strong wooden box can be placed under the engine for added stability

PERIODIC MAINTENANCE AND MINOR REPAIR

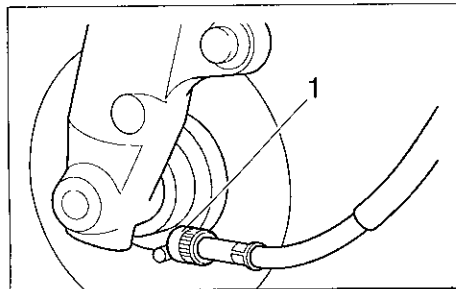

1 Speedometer cable

EAJ24404

Front wheel removal

EUU66202

⚠ WARNING

6

- It is advisable to have a Yamaha dealer service the wheel.
- Securely support the motorcycle so there is no danger of it falling over.

- 1 Remove the speedometer cable from the front wheel side

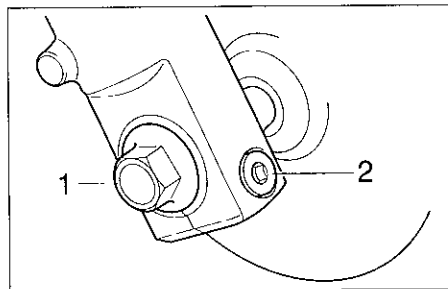

1 Axle

2 Pinch bolt

- 2 Loosen the pinch bolt and wheel axle
3. Elevate the front wheel by placing a suitable stand under the engine
4. Remove the wheel axle and the front wheel

EUU05401

NOTE:

Do not depress the brake lever when the disc and caliper are separated.

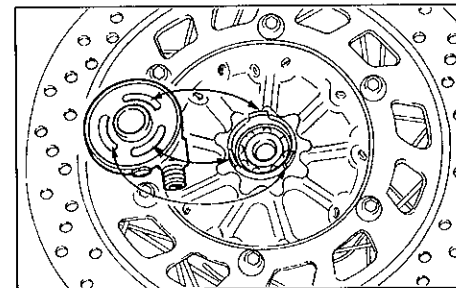

EAJ83600

Front wheel installation

- 1 Install the speedometer gear unit housing into the wheel hub. Make sure the slot in the speedometer gear unit housing fits over the stopper on the front fork outer tube.
- 2 Lift up the wheel between the front fork legs and guide the brake disc between the brake pads.
- 3 Install the wheel axle and tighten it to the specified torque.

Tightening torque.

Wheel axle

59 Nm (5.9 m·kg)

PERIODIC MAINTENANCE AND MINOR REPAIR

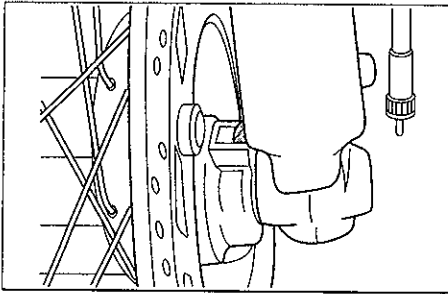

- 4 Push down hard on the handlebars several times to check for proper fork operation.
5. Install the pinch bolt and tighten it to the specified torque

Tightening torque:
Pinch bolt
20 Nm (2.0 m·kg)

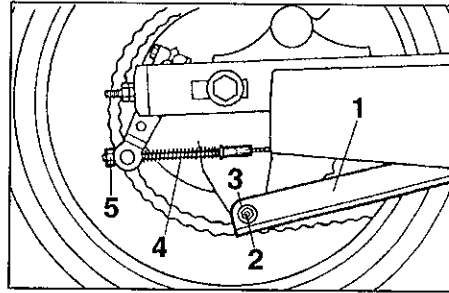

- 1 Tension bar
- 2 Cotter pin
- 3 Nut (tension bar bolt)
- 4 Brake rod
- 5 Adjusting nut (pedal free play)

2. Remove the cotter pin, nut and tension bar bolt from the brake shoe plate
- 3 Remove the rear brake pedal free play adjusting nut and brake rod from the brake cam lever.
4. Loosen the locknuts and chain adjusting nuts on each side.

Rear wheel removal

EAJ31205

EUU66202

⚠ WARNING

- It is advisable to have a Yamaha dealer service the wheel.
- Securely support the motorcycle so there is no danger of it falling over.

1. Elevate the rear wheel by placing a suitable stand under the engine.

PERIODIC MAINTENANCE AND MINOR REPAIR

EAJ34004

EUU64500

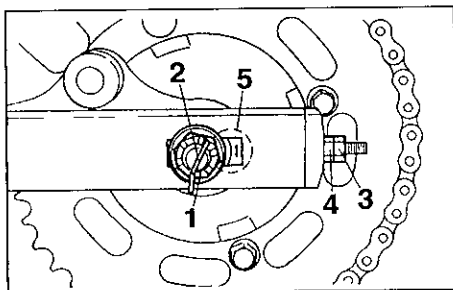

- 1 Axle nut
- 2 Cotter pin
- 3 Locknut
- 4 Adjusting nut
- 5 Alignment marks

Rear wheel installation

- 1 Install the rear wheel and the axle.
- 2 Insert the brake rod into the brake cam lever and install the brake pedal free play adjusting nut.
- 3 Install the tension bar bolt and tighten to the specified tightening torque. Then install the cotter pin.

Specified torque:

Tension bar bolt:
23 Nm (2.3 m·kg)

4. Adjust the drive chain free play. (See page 6-19.)
5. Tighten the axle nut to the specified tightening torque.

Specified torque:

Axle nut
105 Nm (10.5 m·kg)

6. Adjust the rear brake pedal height and free play. (See page 6-15.)

WARNING

Check the operation of the brake light after adjusting the rear brake.

6

5. Remove the axle nut, cotter pin and the axle nut.
6. Pull out the wheel axle and remove the wheel assembly.

PERIODIC MAINTENANCE AND MINOR REPAIR

EAJ50002

Troubleshooting

Although Yamaha motorcycles receive a rigid inspection before shipment from the factory, trouble may occur during operation

Any problem in the fuel, compression, or ignition systems can cause poor starting and loss of power. The troubleshooting chart describes a quick, easy procedure for making checks.

If your motorcycle requires any repair, bring it to a Yamaha dealer. The skilled technicians at a Yamaha dealership have the tools, experience, and know-how to properly service your motorcycle. Use only genuine Yamaha parts on your motorcycle. Imitation parts may look like Yamaha parts, but they are often inferior. Consequently, they have a shorter service life and can lead to expensive repair bills.

PERIODIC MAINTENANCE AND MINOR REPAIR

EAJ51600

Troubleshooting chart

EUU66300

⚠ WARNING

Never check the fuel system while smoking or in the vicinity of an open flame.

1. Fuel

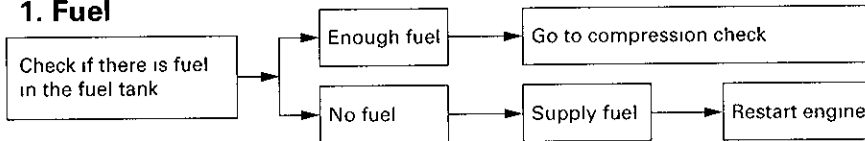

2. Compression

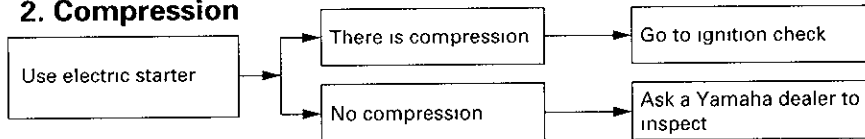

3. Ignition

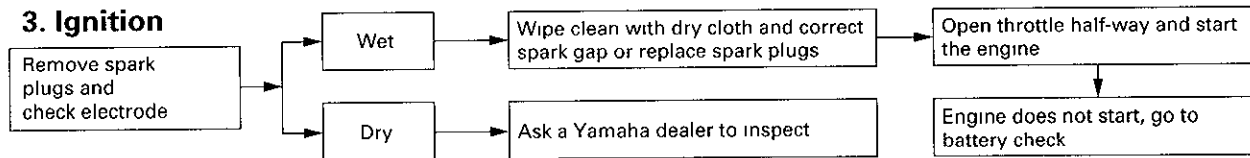

4. Battery

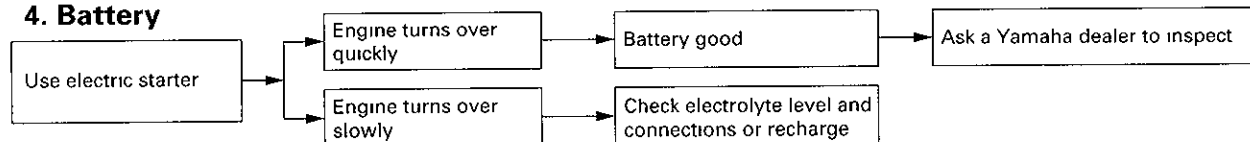

EAK02002

EUU34602

A. CLEANING

Frequent, thorough cleaning of your motorcycle will not only enhance its appearance but will improve its general performance and extend the useful life of many components.

- 1 Before cleaning the motorcycle
 - a Block off the end of the exhaust pipes to prevent water entry, a plastic bag and strong rubber band may be used.
 - b. Make sure the spark plugs and all filler caps are properly installed.
- 2 If the engine case is excessively greasy, apply degreaser with a paint brush. Do not apply degreaser to the chain, sprockets, or wheel axles
- 3 Rinse the dirt and degreaser off with a garden hose Use only enough pressure to do the job

CAUTION

Excessive hose pressure may cause water seepage and deterioration of wheel bearings, front fork, brakes, transmission seals and electrical parts.

Many expensive repair bills have resulted from improper high pressure detergent applications such as those available in coin-operated car washers.

4. After riding on salted roads, wash the motorcycle with cold water immediately. Do not use warm water as it increases the chemical reaction of the salt
5. Once the majority of the dirt has been hosed off, wash all surfaces with warm water and mild, detergent-type soap. An old toothbrush or bottle brush is handy for hard-to-get-at places

6. Rinse the motorcycle off immediately with clean water and dry all surfaces with a chamois, clean towel, or soft absorbent cloth.
7. Dry the chain and lubricate it to prevent rust.
- 8 Clean the seat with a vinyl upholstery cleaner to keep the cover pliable and glossy
9. Automotive type wax may be applied to all painted and chrome-plated surfaces Avoid combination cleaner-waxes Many contain abrasives which may mar the paint or protective finish. When finished, start the engine and let it idle for several minutes.

CLEANING AND STORAGE

B. STORAGE

EAK02105

Long term storage (60 days or more) of your motorcycle will require some preventive procedures to guard against deterioration. After thoroughly cleaning the motorcycle, prepare for storage as follows:

1. Fill the fuel tank with fuel and add fuel stabilizer (if available)
2. Remove each spark plug, pour about one tablespoon of engine oil in each spark plug hole and reinstall the spark plugs. Turn the engine over several times (ground spark plug leads) to coat the cylinder walls with oil.

EUU66400

WARNING

When using the starter motor to crank the engine, remove the spark plug wires, and ground them to prevent sparking.

3. Clean the chain and lubricate it (refer to "Drive chain lubrication")

4. Lubricate all control cables.
5. Block up the frame to raise both wheels off the ground.
6. Tie a plastic bag over the exhaust pipe outlets to prevent moisture from entering.
7. If storing in a humid or salt-air atmosphere, coat all exposed metal surfaces with a light film of oil. Do not apply oil to any rubber parts or the seat cover.
8. Remove the battery and fully charge it. Store it in a cool, dry place and recharge it once a month. Do not store the battery in an excessively warm or cold place (less than 0°C or more than 30°C). See page 6-25 for battery storage precautions.

EUU05800

NOTE: _____
Make any necessary repairs before storing the motorcycle

Specifications

Model	XV250S
Dimensions:	
Overall length	2,190 mm
Overall width	815 mm
Overall height	1,140 mm
Seat height	685 mm
Wheelbase	1,490 mm
Ground clearance	145 mm
Minimum turning radius	2,800 mm
Basic weight (with oil and full fuel tank)	147 kg
Engine:	
Engine type	Air-cooled 4-stroke, SOHC
Cylinder arrangement	V type 2-cylinder
Displacement	249 cm ³
Bore × Stroke	49 × 66 mm
Compression ratio	10.1
Starting system	Electric starter
Lubrication system	Wet sump

Engine oil:

Type

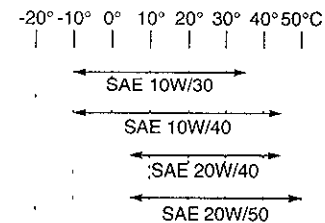

Classification

API Service "SE", "SF" type or equivalent
(e.g. "SF-SE", "SF-SE-CC", "SF-SE-SD" etc.)

Quantity

Periodic oil change	1.4 L
With oil filter replacement	1.6 L
Total amount	1.8 L

Air filter

Wet type element

Fuel:

Type	Regular gasoline
	Unleaded fuel only For Australia
Fuel tank capacity	9.5 L
Reserve amount	2.6 L

SPECIFICATIONS

Carburetor:

Type × quantity	BDS26 × 1
Manufacturer	MIKUNI

Spark plug:

Type/Manufacturer	C6HSA / NGK or U20FS-U / DENSO
-------------------	-----------------------------------

Gap	0.6 ~ 0.7 mm
-----	--------------

Clutch type

Wet, multiple-disc

Transmission:

Primary reduction system	Spur gear
Primary reduction ratio	72/23 (3.130)
Secondary reduction system	Chain drive
Secondary reduction ratio	45/16 (2.813)
Transmission type	Constant mesh 5-speed
Operation	Left foot operation
Gear ratio	1st 37/14 (2.643)
	2nd 32/19 (1.684)
	3rd 29/23 (1.261)
	4th 26/26 (1.000)
	5th 23/28 (0.821)

Chassis:

Frame type	Double cradle
Caster angle	32°
Trail	120 mm

Tire:

Type	Tube
Size	
Front	3.00-18 47P
Rear	130/90-15M/C 66P
Manufacturer/model	
Front	CHENG SHIN / C-916
Rear	CHENG SHIN / C-915
Maximum load*	183 kg
Air pressure (cold tire)	
Up to 90 kg load*	
Front	175 kPa, 1.75 kg/cm ² , 1.75 bar
Rear	200 kPa, 2.00 kg/cm ² , 2.00 bar
90 kg load ~ maximum load*	
Front	200 kPa, 2.00 kg/cm ² , 2.00 bar
Rear	225 kPa, 2.25 kg/cm ² , 2.25 bar

* Load is total weight of cargo, rider, passenger and accessories

Wheels:

Type	
Front	Spoke
Rear	Spoke

SPECIFICATIONS

Size		
	Front	18 × 1 60
	Rear	15M/C × MT 2 75
Brakes:		
Front:		
	Type	Single disc brake
	Operation	Right hand operation
	Fluid	DOT 4 or DOT 3
Rear:		
	Type	Drum brake
	Operation	Right foot operation
Suspension:		
Front:		
	Type	Telescopic fork
	Inner tube outer diameter	33 mm
Rear:		
	Type	Swingarm
Shock absorbers		
	Front	Coil spring / oil damper
	Rear	Coil spring / oil damper
Wheel travel:		
	Front	140 mm
	Rear	100 mm

Electrical system:

Ignition system	T C I (digital)
Charging system	
Type	A C magneto
Standard output	14 V, 25 A @ 5,000 rpm
Battery	
Type	GM10-3A-2
Voltage, capacity	12 V, 10 AH

Headlight type

Quartz bulb (halogen)

Bulb voltage, wattage × quantity:

Headlight	12 V, 60 W / 55 W × 1
Tail/brake light	12 V, 5 W / 21 W × 1
Turn signal lights	12 V, 21 W × 4
Meter light	12 V, 3 W × 1
Neutral indicator light	12 V, 3 W × 1
High beam indicator light	12 V, 17 W × 1
Turn indicator light	12 V, 3 W × 1

Fuses:

Main fuse	20 A
Signaling system fuse	10 A

CONSUMER INFORMATION

EAL10001

HOW TO USE THE CONVERSION TABLE

All specification data in this manual are listed in SI and METRIC UNITS.

Use this table to convert METRIC unit data to IMPERIAL unit data.

Ex

METRIC		MULTIPLIER	=	IMPERIAL
**mm	×	0.03937	=	**in
2 mm	×	0.03937	=	0.08 in

CONVERSION TABLE

METRIC TO IMPERIAL			
	Metric unit	Multiplier	Imperial unit
Torque	m kg	7.233	ft lb
	m kg	86.794	in lb
	cm kg	0.0723	ft lb
	cm kg	0.8679	in lb
Weight	kg	2.205	lb
	g	0.03527	oz
Speed	km/hr	0.6214	mph
Distance	km	0.6214	mi
	m	3.281	ft
	m	1.094	yd
	cm	0.3937	in
	mm	0.03937	in
Volume / Capacity	cc (cm ³)	0.03527	oz (IMP liq)
	cc (cm ³)	0.06102	cu in
	lt (liter)	0.8799	qt (IMP liq)
	lt (liter)	0.2199	gal (IMP liq)
Misc	kg/mm	55.997	lb/in
	kg/cm ²	14.2234	psi (lb/in ²)
	Centigrade (°C)	9/5 + 32	Fahrenheit (°F)

EAA61800

Identification numbers record

Record the key identification number, vehicle identification number and model label information in the spaces provided for assistance when ordering spare parts from a Yamaha dealer or for reference in case the vehicle is stolen.

1 KEY IDENTIFICATION NUMBER

2 VEHICLE IDENTIFICATION NUMBER

3 MODEL LABEL INFORMATION:

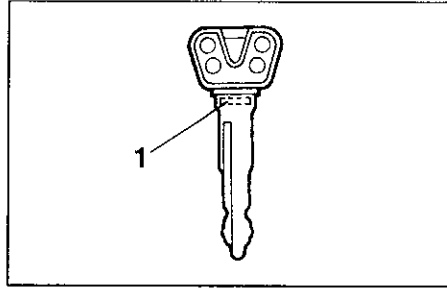

1 Key identification number

EAA61400

Key identification number

The key identification number is stamped on the key. Record this number in the space provided and use it for reference when obtaining a new key

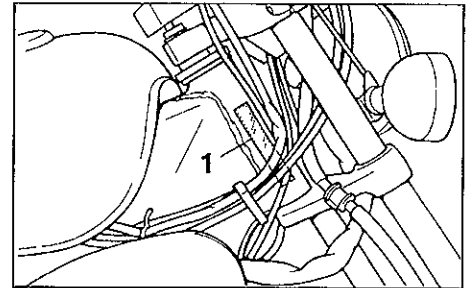

1 Vehicle identification number

EAA80001

Vehicle identification number

The vehicle identification number is stamped into the steering head pipe. Record this number in the space provided.

EUU00400

NOTE: _____

The vehicle identification number is used to identify your motorcycle and may be used to register your motorcycle with the licensing authority in your state

CONSUMER INFORMATION

EAL00800

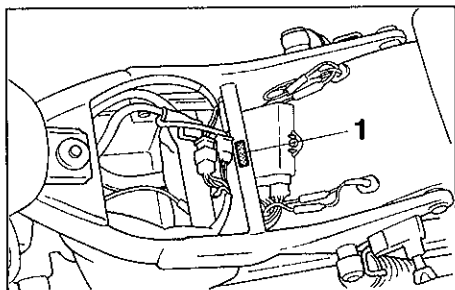

1 Model label

EAA62200

Model label

The model label is affixed to the frame under the seat. (See page 3-9 for seat removal procedures.) Record the information on this label in the space provided. This information will be needed to order spare parts from your Yamaha dealer

NOISE REGULATION (FOR Australia)

"TAMPERING WITH NOISE CONTROL SYSTEM PROHIBITED"

Owners are warned that the law may prohibit:

- (a) The removal or rendering inoperative by any person other than for purposes of maintenance, repair or replacement, of any device or element of design incorporated into any new vehicle for the purpose of noise control prior to its sale or delivery to the ultimate purchaser or while it is in use; and
- (b) the use of the vehicle after such device or element of design has been removed or rendered inoperative by any person

PRINTED ON RECYCLED PAPER

YAMAHA
YAMAHA MOTOR CO., LTD

PRINTED IN JAPAN
97 · 7 - 03 × 1 CR
(E)