



**Includes:**

- Important Safety Information
- Operating Instructions
- Maintenance and Storage

**Ninja 650**  
**Ninja 650 ABS**  
**Motorcycle**

**OWNER'S MANUAL**

# Quick Reference Guide

This Quick Reference Guide will assist you in finding the information you're looking for.

**GENERAL INFORMATION**

**HOW TO RIDE THE MOTORCYCLE**

**SAFE OPERATION**

**MAINTENANCE AND ADJUSTMENT**

**STORAGE**

**TROUBLESHOOTING GUIDE**

A Table of Contents is included after the Foreword.

Whenever you see the symbols shown below, heed their instructions! Always follow safe operating and maintenance practices.

 **DANGER**

**DANGER** indicates a hazardous situation which, if not avoided, will result in death or serious injury.

 **WARNING**

**WARNING** indicates a hazardous situation which, if not avoided, could result in death or serious injury.

**NOTICE**

**NOTICE** is used to address practices not related to personal injury.

**NOTE**

○ *NOTE* indicates information that may help or guide you in the operation or service of the vehicle.

 **WARNING**

Engine exhaust, some of its constituents, and certain vehicle components contain or emit chemicals known to the State of California to cause cancer and birth defects or other reproductive harm.

***NOTICE***

**THIS PRODUCT HAS BEEN MANUFACTURED FOR USE IN A REASONABLE AND PRUDENT MANNER BY A QUALIFIED OPERATOR AND AS A VEHICLE ONLY.**

## FOREWORD

Congratulations on your purchase of a new Kawasaki motorcycle. Your new motorcycle is the product of Kawasaki's advanced engineering, exhaustive testing, and continuous striving for superior reliability, safety and performance.

**Please read this Owner's Manual carefully before riding** so that you will be thoroughly familiar with the proper operation of your motorcycle's controls, its features, capabilities, and limitations. This manual offers many safe riding tips, but its purpose is not to provide instruction in all the techniques and skills required to ride a motorcycle safely. Kawasaki strongly recommends that all operators of this vehicle enroll in a motorcycle rider training program to attain awareness of the mental and physical requirements necessary for safe motorcycle operation.

To ensure a long, trouble-free life for your motorcycle, give it the proper care and maintenance described in this manual. For those who would like more detailed information on their Kawasaki Motorcycle, a Service Manual is available for purchase from any authorized Kawasaki motorcycle dealer. The Service Manual contains detailed disassembly and maintenance information. Those who plan to do their own work should, of course, be competent mechanics and possess the special tools described in the Service Manual.

Keep this Owner's Manual aboard your motorcycle at all times so that you can refer to it whenever you need information.

This manual should be considered a permanent part of the motorcycle and should remain with the motorcycle when it is sold.

All rights reserved. No part of this publication may be reproduced without our prior written permission.

This publication includes the latest information available at the time of printing. However, there may be minor differences between the actual product and illustrations and text in this manual.

All products are subject to change without prior notice or obligation.

**KAWASAKI HEAVY INDUSTRIES, LTD.**  
**Motorcycle & Engine Company**

---

## TABLE OF CONTENTS

---

<b>SPECIFICATIONS</b> .....	9	Passing Button: .....	39
<b>SERIAL NUMBER LOCATIONS</b> .....	13	Hazard Switch: .....	39
<b>LOCATION OF PARTS</b> .....	14	Brake/Clutch Lever Adjusters.....	40
<b>LOADING AND ACCESSORIES</b>		Fuel Tank Cap .....	41
<b>INFORMATION</b> .....	17	Fuel Tank .....	42
<b>GENERAL INFORMATION</b> .....	20	Fuel Requirement .....	43
Meter Instruments .....	20	Stand.....	47
Tachometer .....	21	Seats.....	48
Multifunction Meter.....	22	Helmet Hooks.....	50
Multifunction Display.....	24	Tool Kit .....	51
Warning/Indicator Lights: .....	31	Tying Hooks .....	52
Keys .....	34	Windshield.....	52
Ignition Switch/Steering Lock.....	35	<b>BREAK-IN</b> .....	54
Right Handlebar Switches.....	37	<b>HOW TO RIDE THE MOTORCYCLE</b> .	56
Engine Stop Switch: .....	37	Starting the Engine .....	56
Starter Button: .....	38	Jump Starting.....	58
Left Handlebar Switches .....	38	Moving Off.....	61
Dimmer Switch: .....	38	Shifting Gears .....	62
Turn Signal Switch:.....	39	Braking.....	64
Horn Button: .....	39		

Anti-lock Brake System (ABS) for models equipped with ABS.....	65	Throttle Control System .....	118
Yellow ABS Indicator Light:.....	67	Engine Vacuum Synchronization .....	121
Stopping the Engine.....	68	Idle Speed .....	121
Stopping the Motorcycle in an Emergency .....	69	Clutch.....	123
Parking .....	70	Drive Chain .....	125
Catalytic Converter.....	72	Brakes.....	132
<b>SAFE OPERATION</b> .....	74	Brake Light Switches.....	136
Safe Riding Technique .....	74	Front Fork.....	139
Daily Checks .....	77	Rear Shock Absorber.....	140
Additional Considerations for High Speed Operation .....	80	Wheels .....	143
<b>MAINTENANCE AND ADJUSTMENT</b> .....	82	Battery.....	148
Periodic Maintenance Chart.....	87	Headlight Beam.....	153
Engine Oil .....	99	Fuses .....	155
Cooling System .....	105	General Lubrication.....	157
Spark Plugs.....	113	Cleaning Your Motorcycle .....	159
Evaporative Emission Control System (California model only).....	114	Bolt and Nut Tightening.....	164
Kawasaki Clean Air System.....	115	<b>STORAGE</b> .....	166
Valve Clearance .....	116	<b>TROUBLESHOOTING GUIDE</b> .....	169
Air Cleaner .....	117	<b>YOUR WARRANTY/OWNER</b>	
		<b>SATISFACTION</b> .....	170
		<b>REPORTING SAFETY DEFECTS</b> .....	176
		<b>ENVIRONMENTAL PROTECTION</b> .....	177
		<b>MAINTENANCE RECORD</b> .....	178



**LOCATION OF LABELS..... 186**

---

## SPECIFICATIONS

---

### PERFORMANCE

Minimum Turning Radius 2.7 m (106.3 in.)

### DIMENSIONS

Overall Length 2 110 mm (83.07 in.)

Overall Width 770 mm (30.31 in.)

Overall Height 1 180 mm (46.46 in.)

Wheelbase 1 410 mm (55.51 in.)

Road Clearance 130 mm (5.12 in.)

Curb Mass (E) 209 kg (461 lb)

(F) 211 kg (465 lb)

### ENGINE

Type DOHC, 4-valve, 2-cylinder, 4-stroke, liquid-cooled

Displacement 649 cm<sup>3</sup> (39.6 cu in.)

Bore × Stroke 83.0 × 60.0 mm (3.27 × 2.36 in.)

Compression Ratio 10.8 : 1

## 10 SPECIFICATIONS

Starting System	Electric starter
Cylinder Numbering Method	Left to right, 1-2
Firing Order	1-2
Fuel System	FI (Fuel Injection)
Ignition System	Battery and coil (transistorized ignition)
Ignition Timing (Electronically advanced)	10° BTDC @1 300 r/min (rpm) ~ 37° BTDC @5 000 r/min (rpm)
Spark Plugs	NGK CR9EIA-9
Lubrication System	Forced lubrication (semi-dry sump)
Engine Oil	Type : API SG, SH, SJ, SL or SM with JASO MA, MA1 or MA2
	Viscosity: SAE 10W-40
	Capacity: 2.3 L (2.4 US qt)
Coolant Capacity	1.2 L (1.3 US qt)

## TRANSMISSION

Transmission Type	6-speed, constant mesh, return shift
Clutch Type	Wet, multi disc

Driving System		Chain drive
Primary Reduction Ratio		2.095 (88/42)
Final Reduction Ratio		3.067 (46/15)
Overall Drive Ratio		5.473 (Top gear)
Gear Ratio	1st	2.438 (39/16)
	2nd	1.714 (36/21)
	3rd	1.333 (32/24)
	4th	1.111 (30/27)
	5th	0.966 (28/29)
	6th	0.852 (23/27)

**FRAME**

Castor		25°
Trail		110 mm (4.3 in.)
Tire Size:	Front	120/70ZR17 M/C (58 W)
	Rear	160/60ZR17 M/C (69 W)
Rim Size:	Front	J17M/C × MT3.50
	Rear	J17M/C × MT4.50

## 12 SPECIFICATIONS

Fuel Tank Capacity	16 L (4.2 US gal)
--------------------	-------------------

### **ELECTRICAL EQUIPMENT**

Battery	12 V 10 Ah
---------	------------

Headlight	12 V 55 W/55 W (Hi/Lo)
-----------	------------------------

Tail/Brake Light	LED
------------------	-----

Even if one of LED (Light Emitting Diode) tail/brake light does not go on, consult with an authorized Kawasaki dealer.

Specifications are subject to change without notice.

(E): EX650E

(F): EX650F

---

## SERIAL NUMBER LOCATIONS

---

The engine and frame serial numbers are used to register the motorcycle. They are the only means of identifying your particular machine from others of the same model type. These serial numbers may be needed by your dealer when ordering parts. In the event of theft, the investigating authorities will require both numbers as well as the model type and any peculiar features of your machine that can help them identify it.

### Frame No.

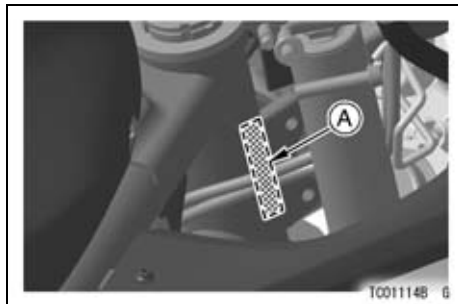

A. Frame Number

### Engine No.

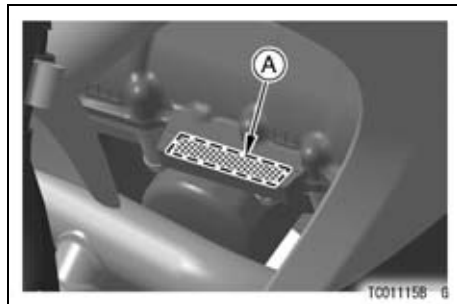

A. Engine Number

## LOCATION OF PARTS

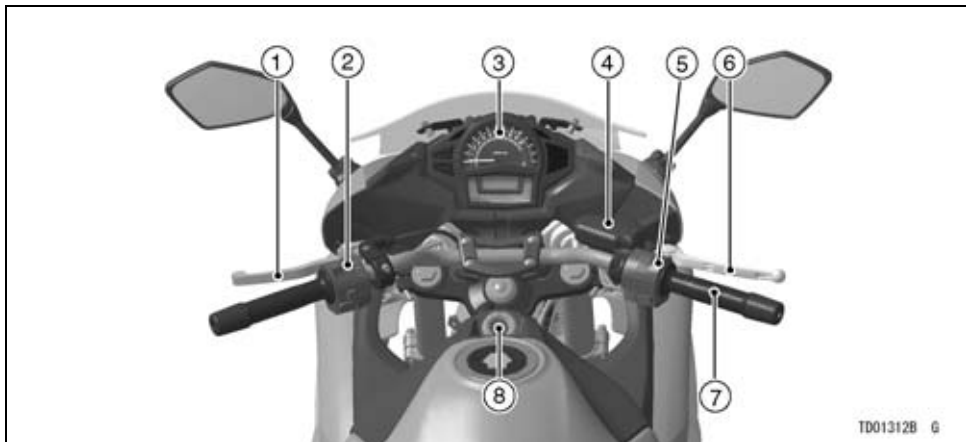

TD01312B G

1. Clutch Lever
2. Left Handlebar Switches
3. Meter Instruments
4. Brake Fluid Reservoir (Front)

5. Right Handlebar Switches
6. Front Brake Lever
7. Throttle Grip
8. Ignition Switch/Steering Lock

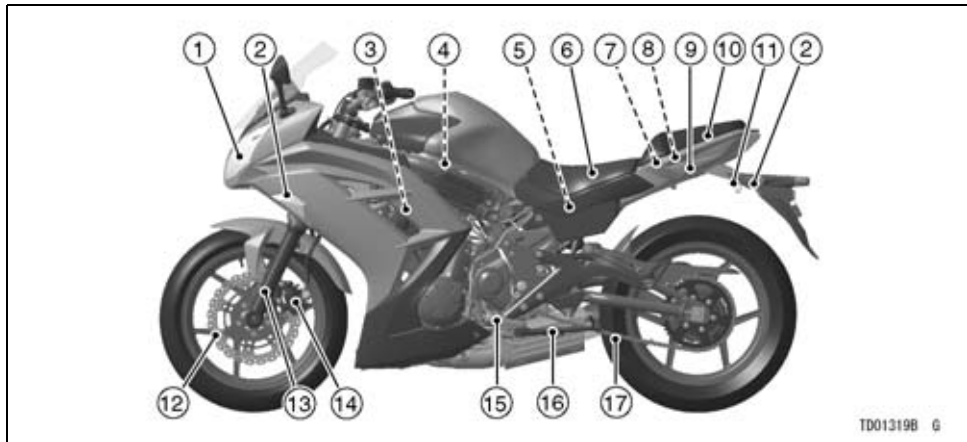

1. Headlight
2. Turn Signal Light
3. Spark Plugs
4. Air Cleaner
5. Battery
6. Rider's Seat

7. Helmet Holding Hooks
8. Tool Kit
9. Seat Lock
10. Passenger's Seat
11. Tying Hooks

12. Brake Disc
13. Front Fork
14. Brake Caliper
15. Shift Pedal
16. Side Stand
17. Drive Chain



## 16 LOCATION OF PARTS

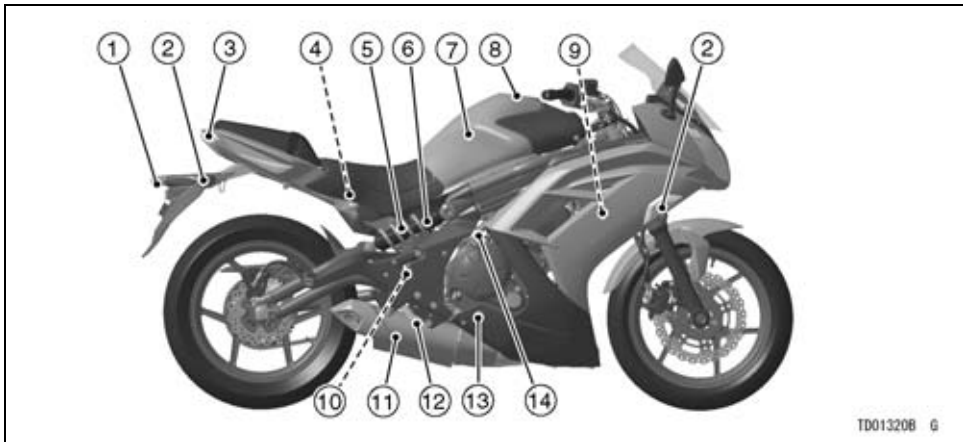

TD01320B G

- |                                 |                                 |
|---------------------------------|---------------------------------|
| 1. License Plate Light          | 8. Fuel Tank Cap                |
| 2. Turn Signal Light            | 9. Coolant Reserve Tank         |
| 3. Tail/Brake Light             | 10. Rear Brake Light Switch     |
| 4. Brake Fluid Reservoir (Rear) | 11. Muffler                     |
| 5. Rear Shock Absorber          | 12. Rear Brake Pedal            |
| 6. Spring Preload Adjuster      | 13. Oil Level Inspection Window |
| 7. Fuel Tank                    | 14. Idle Adjusting Screw        |

---

**LOADING AND ACCESSORIES INFORMATION**

---

 **WARNING**

**Incorrect loading, improper installation or use of accessories, or modification of your motorcycle may result in an unsafe riding condition. Before you ride the motorcycle, make sure it is not overloaded and that you have followed these instructions.**

With the exception of genuine Kawasaki Parts and Accessories, Kawasaki has no control over the design or application of accessories. In some cases, improper installation or use of accessories, or motorcycle modification, will void the motorcycle warranty, can negatively affect performance, and can even be illegal.

In selecting and using accessories, and in loading the motorcycle, you are personally responsible for your own safety and the safety of other persons involved.

**NOTE**

○ *Kawasaki Parts and Accessories have been specially designed for use on Kawasaki motorcycles. We strongly recommend that all parts and accessories you add to your motorcycle be genuine Kawasaki components.*

Because a motorcycle is sensitive to changes in weight and aerodynamic forces, you must take extreme care in carrying cargo, passengers and/or in

## 18 LOADING AND ACCESSORIES INFORMATION

fitting additional accessories. The following general guidelines have been prepared to assist you in making your determinations.

1. Any passenger should be thoroughly familiar with motorcycle operation. The passenger can affect control of the motorcycle by improper positioning during cornering and sudden movements. It is important that the passenger sit still while the motorcycle is in motion and not interfere with the operation of the motorcycle. Do not carry animals on your motorcycle.
2. You should instruct any passenger before riding to keep his feet on the passenger footpegs and hold on to the operator or seat strap. Do not carry a passenger unless he or she is tall enough to reach the footpegs and footpegs are provided.
3. All baggage should be carried as low as possible to reduce the effect on the motorcycle center of gravity. Baggage weight should also be distributed equally on both sides of the motorcycle. Avoid carrying baggage that extends beyond the rear of the motorcycle.
4. Baggage should be securely attached. Make sure that the baggage will not move around while you are riding. Recheck baggage security as often as possible (not while the motorcycle is in motion) and adjust as necessary.
5. Do not carry heavy or bulky items on a luggage rack. They are designed for light items, and overloading can affect handling due to changes in weight distribution and aerodynamic forces.

6. Do not install accessories or carry baggage that impairs the performance of the motorcycle. Make sure that you have not adversely affected any lighting components, road clearance, banking capability (i.e., lean angle), control operation, wheel travel, front fork movement, or any other aspect of the motorcycle's operation.
7. Weight attached to the handlebar or front fork will increase the mass of the steering assembly and can result in an unsafe riding condition.
8. Fairings, windshields, backrests, and other large items have the capability of adversely affecting stability and handling of the motorcycle, not only because of their weight, but also due to the aerodynamic forces acting on these surfaces while the motorcycle is in operation. Poorly designed or installed items can result in an unsafe riding condition.
9. This motorcycle is not intended to be equipped with a sidecar or to be used to tow any trailer or other vehicle. Kawasaki does not manufacture sidecars or trailers for motorcycles and cannot predict the effects of such accessories on handling or stability, but can only warn that the effects can be adverse and that Kawasaki cannot assume responsibility for the results of such unintended use of the motorcycle. Furthermore, any adverse effects on motorcycle components caused by the use of such accessories will not be remedied under warranty.

**Maximum Load**

Weight of rider, passenger, baggage, and accessories must not exceed 200 kg (441 lb).

## GENERAL INFORMATION

## Meter Instruments

- A. MODE Button
- B. Green Left Turn Signal Indicator Light
- C. Tachometer
- D. Red Zone
- E. Green Right Turn Signal Indicator Light
- F. Yellow ABS Indicator Light (Only on ABS model)
- G. Yellow Engine Warning Indicator Light
- H. Red Battery Voltage Warning Indicator Light
- I. RESET Button
- J. Multifunction Meter
- K. Green Neutral Indicator Light
- L. Blue High Beam Indicator Light
- M. Red Coolant Temperature Warning Indicator Light
- N. Red Oil Pressure Warning Indicator Light

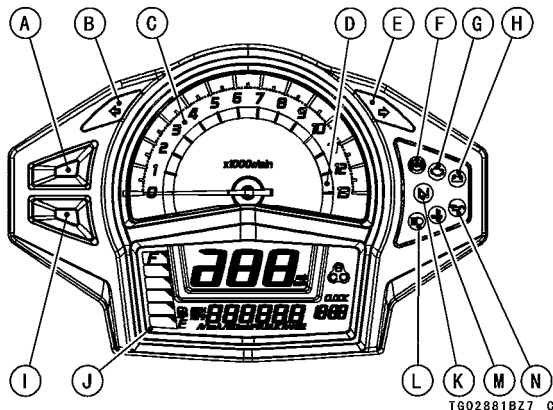

**NOTE**

- For safety, do not operate the instrument buttons while riding the motorcycle.

**Tachometer**

The tachometer shows the engine speed in revolutions per minute (r/min, rpm). On the right side of the tachometer face is a portion called the “red zone”. Engine r/min (rpm) in the red zone is above maximum recommended engine speed and is also above the range for good performance.

**NOTICE**

**Engine r/min (rpm) should not be allowed to enter the red zone; operation in the red zone will overstress the engine and may cause serious engine damage.**

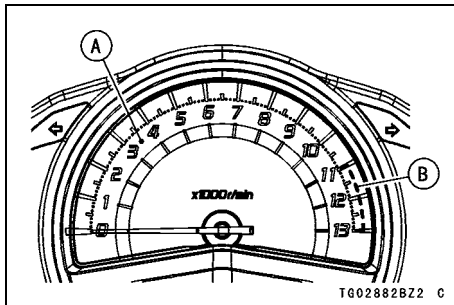

- A. Tachometer
- B. Red Zone

When the ignition key is turned to “ON”, the tachometer needle momentarily goes from the minimum to the maximum, then goes back from the maximum to the minimum reading to check its operation. If the tachometer does not operate correctly, have it checked by an authorized Kawasaki dealer.

## 22 GENERAL INFORMATION

### Multifunction Meter

The multifunction meter displays the following functions.

- A. Fuel Gauge
- B. Speedometer
- C. Economical Riding Indicator
- D. Fuel Level Warning Symbol
- E. Multifunction Display
  - Odometer
  - Trip meter A
  - Trip meter B
  - Current Mileage
  - Average Mileage
  - Cruising Range
- F. Clock

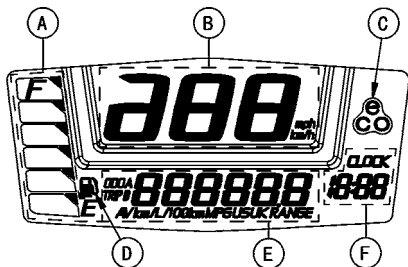

TG02883BZ2 C

When the ignition key is turned to "ON", all LCD segments are displayed with opening display functions for few seconds, then the multifunction meter turns to operational mode.

## Speedometer -

The speedometer shows the speed of the vehicle in digital values.

## Unit Setting -

The unit setting in the meter instrument can be changed according to local regulations. Make sure the unit setting is correctly displayed before riding.

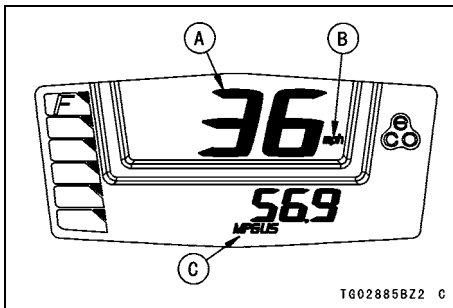

- A. Speedometer
- B. Speed Unit
- C. Mileage Unit

## NOTE

- Do not operate the motorcycle with wrong unit (mph or km/h) of the speedometer.

To change the meter display units in the meter instrument as follows:

- Display the odometer in the multi-function display. Refer to the Multi-function Display section.
- Push the RESET button while pushing the MODE button to select the display units.

L/100km (km/h) → km/L (km/h) → MPG US (mph) → MPG UK (mph) → L/100km (km/h)...

- The display units on the multifunction meter can be changed depending on the selected mileage unit as shown.



## 24 GENERAL INFORMATION

Mileage Units	Speed Units	Distance Units
L/100km	km/h	km
km/L		
MPG US	mph	mile
MPG UK		

### Multifunction Display

The following display modes can be shifted by pushing the MODE button.

Odometer → Trip meter A → Trip meter B → Current Mileage → Average Mileage → Cruising Range → Odometer...

### NOTE

- *For safety, do not operate the instrument buttons while riding the motorcycle.*
- *The multifunction display is displayed in the unit depending on the*

*unit mode setting, refer to the “Unit Setting” item in this section.*

### Odometer -

The odometer shows the total distance in kilometers or miles that the vehicle has been ridden. This meter cannot be reset.

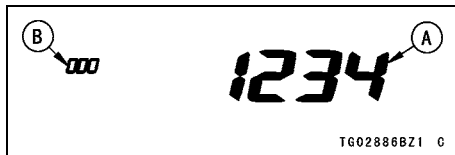

- A. Odometer
- B. “ODO”

### NOTE

- *The data is maintained even if the battery is disconnected.*
- *When the figures come to 999999, they are stopped and locked.*

**Trip Meter -**

The trip meters show the distance in kilometers (miles) traveled since they were last reset to zero.

TRIP A: 0.0 ~ 9999.9

TRIP B: 0.0 ~ 9999.9

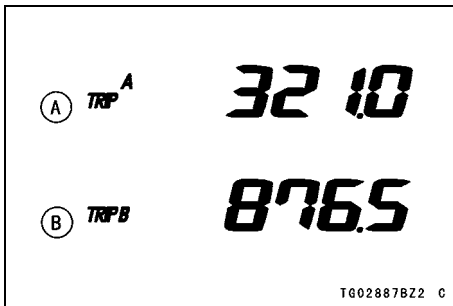

A. Trip A

B. Trip B

To reset the trip meter:

- Push the MODE button to display the trip meter A or B.

- Push the RESET button and hold it in.
- After two seconds, the figure display turns to 0.0, and then starts counting when the vehicle is operated. The meter counts until it is reset.

**NOTE**

- *The data is maintained by the back-up power if the ignition key is turned off.*
- *When the trip meter reaches 9999.9 while running, the meters reset to 0.0 and continues counting.*
- *When the battery is disconnected, the meter display resets to 0.0.*

**Current Mileage -**

This display mode shows the current mileage by numerical value. The current mileage display is renewed every 4 seconds.



- A. Current Mileage  
B. "km/L"

### NOTE

- *The display unit modes can be changed, refer to the "Unit Setting" item in this section.*
- *The numerical value shows "--. --" until 4 seconds have passed and the speedometer is rises to above 5 km/h (3 mph).*

### Average Mileage -

This display mode shows the average mileage by numerical value counted from the start of measuring to present time. The average mileage

display is renewed every 4 ~ 6 seconds.

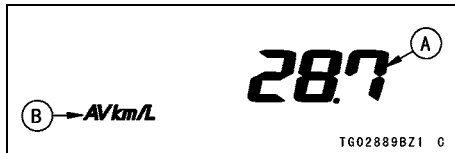

- A. Average Mileage  
B. "AV km/L"

- While the average mileage is displayed, push the RESET button and hold it in until the average mileage values resets to "--. --".

### NOTE

- *The display unit modes can be changed, refer to the "Unit Setting" item in this section.*
- *After resetting the average mileage, the numerical value is not displayed until 5 mL (0.2 US oz.) of fuel has*

*been used and 100 m (328 ft) has been traveled.*

- *The data is maintained by back up power if the ignition switch is turned "OFF".*
- *When the battery is disconnected, the data resets to "--."*

### **Cruising Range -**

This display shows the cruising range by numerical value and indicates the cruising range from the remaining fuel in the fuel tank. This cruising range display is renewed every 20 seconds.

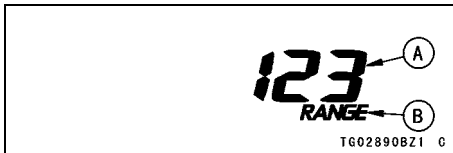

- A. Cruising Range
- B. "RANGE"

The cruising range value displays "--" when the fuel warning symbol (⛽) blinks in the multifunction meter.

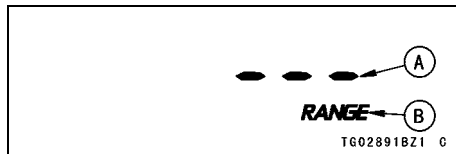

- A. "--" display
- B. "RANGE"

### **NOTE**

- *The display unit modes can be changed, refer to the "Unit Setting" in this section.*
- *The display range for cruising range is 0 ~ 999.*
- *The cruising range value may not indicate the actual value. Use this value for your reference only.*

## 28 GENERAL INFORMATION

### Clock -

To adjust hours and minutes, do the followings while the motorcycle is at a stop.

- Turn the ignition switch to “ON”.
- Display the odometer in the multi-function display. Refer to the “Multi-function Display” item in this section.
- Push the RESET button for more than 2 seconds. Both the hour and minute displays start blinking.

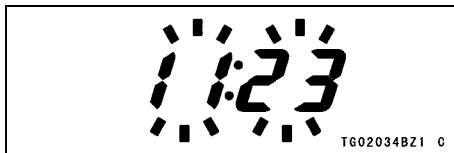

- Push the RESET button. The hour display only blinks. Push the MODE button to advance the hours.

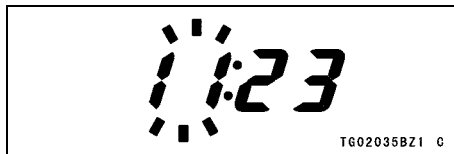

- Push the RESET button. The hour display stops blinking and the minute display starts blinking. Push the MODE button to advance the minutes.

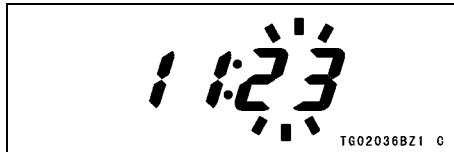

- Push the RESET button. Both the hour and minute displays start blinking again.
- Push the MODE button. The displays stop blinking and the clock starts working.

**NOTE**

- *Pushing the MODE button momentarily advances the hour or minute step by step. Pushing and holding the button advances the hour or minute continuously.*
- *The clock works normally by the back-up power while the ignition switch is turned "OFF".*
- *When the battery is disconnected, the clock is reset to 1:00 and starts working again when the battery is connected.*

**Economical Riding Indicator -**

When the operator is driving the motorcycle for optimum fuel-efficiency, the economical riding indicator appears on the multifunction meter to indicate favorable fuel consumption. Monitoring the economical riding indicator can help the rider maximize fuel efficiency.

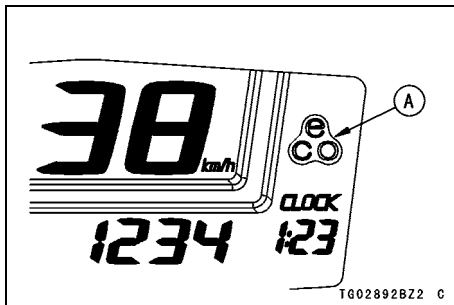

A. Economical Riding Indicator

**⚠ WARNING**

**Failing to properly observe the road ahead increases the chance of an accident resulting in severe injury or death. Do not concentrate on the economical riding indicator by taking your eyes off the road; observe using peripheral vision.**

## 30 GENERAL INFORMATION

### Fuel Gauge –

The fuel in the fuel tank is shown by the number of segments displayed. When the fuel tank is full, all 6 segments are displayed.

If the fuel gauge is not correctly displayed, have the fuel gauge checked by an authorized Kawasaki dealer.

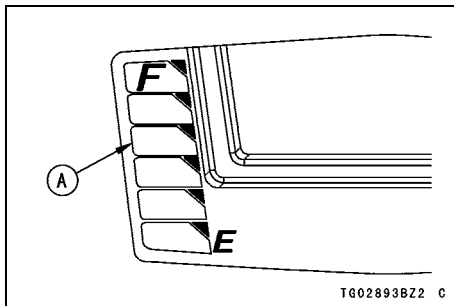

A. Fuel Gauge

As the fuel level in the tank goes down, the segments disappear one by one from F (full) to E (empty). When

only the last 1 segment (E) is displayed in the fuel gauge, the fuel warning symbol (⛽) and the segment (E) are blinks.

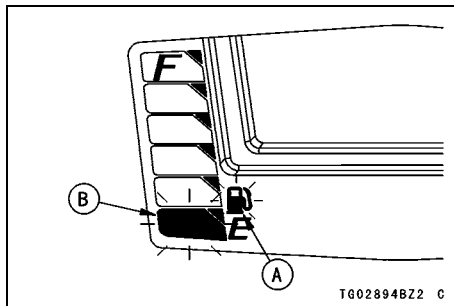

- A. Fuel Warning Symbol (⛽)
- B. Segment (E)

This indicates that the remaining fuel in the tank is approximately 4 L (1.1 US gal). Refuel at the earliest opportunity if the fuel warning symbol (⛽) is displayed in the multifunction meter.

When vehicle stands with Side Stand, Fuel Gauge cannot show the amount of fuel in the fuel tank exactly. Stand upright the vehicle to check the fuel level.

All of the segments and fuel symbol will blink in case of the open or short of the wiring. Have the wiring inspected by an authorized Kawasaki dealer immediately.

### NOTE

- *When pushing the MODE button while low fuel warning is displayed, the multifunction display modes can be shifted.*
- *The cruising range value indicate the “— — —” when the low fuel warning is displayed.*

### Warning/Indicator Lights:

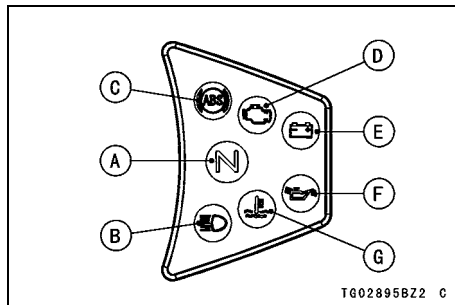



- A. Green Neutral Indicator Light**
- B. Blue High Beam Indicator Light**
- C. Yellow ABS Indicator Light (Only on ABS model)**
- D. Yellow Engine Warning Indicator Light**
- E. Red Battery Voltage Warning Indicator Light**
- F. Red Oil Pressure Warning Indicator Light**
- G. Red Coolant Temperature Warning Indicator Light**

**N:** When the transmission is in neutral, the neutral indicator light goes on.



## 32 GENERAL INFORMATION

 : When the headlight is on high beam, the high beam indicator light goes on.

 : When the turn signal switch is pushed to the left or right, the corresponding turn signal indicator light blinks.

### **Yellow ABS Indicator Light (For models equipped with ABS)**

 : The ABS (Anti-lock Brake System) indicator light goes on when the ignition switch is turned on and goes off shortly after the motorcycle starts moving. If the ABS is normal, it stays off. If something is wrong with the ABS, the indicator goes on and stays on. When the indicator light is on, the ABS does not function but if the ABS fails, the conventional brake system will still work normally.

For more detailed information about ABS, see the Anti-lock Brake System (ABS) section in the How to Ride the Motorcycle chapter.

### **Yellow Engine Warning Indicator Light**

 : The engine warning indicator light goes on when the ignition key is turned to “ON” and goes off soon after ensuring that its circuit functions properly. The indicator light also goes on or blinking whenever the troubles occur in digital fuel injection system (DFI).

The blinking of this indicator light indicates the condition that the engine cannot be started.

Refer to the Stopping the Engine section of the “How to Ride the Motorcycle” chapter for more information. If the indicator light goes on, have the DFI system checked by an authorized Kawasaki dealer.

## Red Warning Indicator Lights

If any red warning indicator light goes on with the engine running, have its cause checked by an authorized Kawasaki dealer.

: This warning indicator light should go on whenever the ignition switch is turned to "ON" and go off after starting the engine.

The oil pressure warning indicator light goes on whenever the oil pressure is dangerously low while the engine running. Refer to the Maintenance and Adjustment chapter for more detailed engine oil information.

: The coolant temperature warning indicator light goes on whenever the coolant temperature rises to 118°C (245°F) when the motorcycle is in operation. This warns the operator that the coolant temperature is too high.

If the warning indicator light goes on, stop the engine and check the coolant level in the reserve tank after the engine cools down.

### **NOTICE**

**Do not let the engine continue running when the warning indicator light goes on. Prolonged engine operation will result in severe damage from overheating.**

: The battery charging system warning indicator light goes on whenever the battery voltage is less than 11 V or higher than 16 V.

The warning indicator light and the battery warning indicator light still go on even after the battery is charged, ask an authorized Kawasaki dealer for an inspection.

## 34 GENERAL INFORMATION

### Keys

This motorcycle has a combination key, which is used for the ignition switch, steering lock, seat lock, and fuel tank cap.

Included with the key is a key number, which may be stamped on a separate plate. Record the key number in the space provided and store the number in a safe place. If your keys came with a plate, store it in a safe place as well.

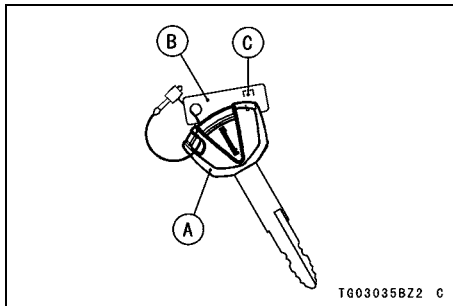

- A. Ignition Key
- B. Tag
- C. Key Number

Write your key number here.

In the event you lose your keys, you will need the key number to have a duplicate made. If you cannot locate your key number, contact the dealer where you purchased your Kawasaki motorcycle. It's possible the dealer may have the number in its records. If the key number is lost completely, you will need to replace the ignition switch and all other locks operated by that key.

Contact your Kawasaki dealer to purchase additional spare keys either using your original key as a master or using the key code on the tag or your key. Store one key at home and keep another spare in your wallet or riding gear, in case the original is lost.

## Ignition Switch/Steering Lock

This is a four-position, key-operated switch. The key can be removed from the switch when it is in the OFF, LOCK, or  position.

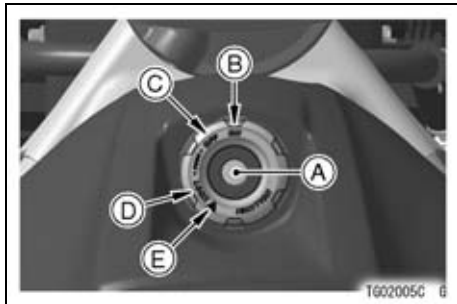

- A. Ignition Switch/Steering Lock
- B. ON position
- C. OFF position
- D. LOCK position
- E.  position

## 36 GENERAL INFORMATION

<b>OFF</b>	Engine off. Electrical circuits off.
<b>ON</b>	Engine on. All electrical equipment can be used.
<b>LOCK</b>	Steering locked. Engine off. Electrical circuits off.
	Steering locked. Engine off. Turn signals can be used. Other electrical circuits off.

### NOTE

- *The city, tail and license plate lights are on whenever the ignition key is in the ON position. One headlight goes on when the starter button is released after starting the engine. To avoid battery discharge, always start the engine immediately after turning the ignition key to "ON".*

To operate the ignition Switch:

LOCK ← OFF ↔ ON



1. Turn the handlebar fully to the left.
2. For locking push down the key in the OFF position and turn it to LOCK.

T604142B22 C

## **NOTICE**

**Do not use a metallic or heavy key ring or related accessory or put other keys on the same key ring as they could contact and damage your motorcycle. When your key is in the ignition, make sure the handlebars can be turned fully right and left without any interference. If a spare key or accessory becomes trapped, it could restrict steering operation, snap the ignition key or damage the ignition switch.**

## **Right Handlebar Switches**

### **Engine Stop Switch:**

In addition to the ignition switch, the engine stop switch must be in the  position for the motorcycle to operate.

The engine stop switch is for emergency use. If required, move the engine stop switch to the  position.

### **NOTE**

- *Although the engine stop switch stops the engine, it does not turn off all the electrical circuits. Ordinarily, the ignition switch should be used to stop the engine.*

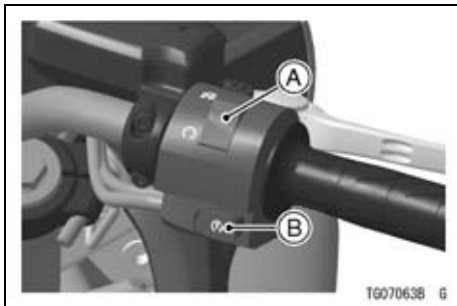

- A. Engine Stop Switch
- B. Starter Button

### Starter Button:

The starter button operates the electric starter when the transmission is in neutral.

Refer to the Starting the Engine section of the “How to Ride the Motorcycle” chapter for starting instructions.

## Left Handlebar Switches

### Dimmer Switch:

High or low beam can be selected with the dimmer switch. When the headlight is on high beam (  ), the high beam indicator light is lit.

High beam.....(  )

Low beam.....(  )

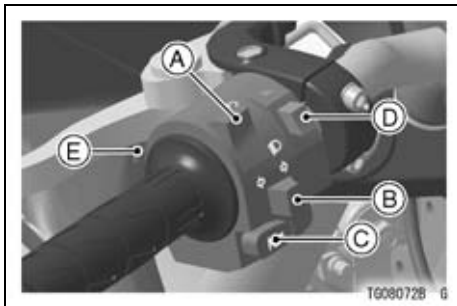

### NOTE

- *When the headlight is on high beam, both head lights go on. When the headlight is on low beam, only one headlight goes on.*



- A. Dimmer Switch
- B. Turn Signal Switch
- C. Horn Button
- D. Hazard Switch
- E. Passing Button

### Turn Signal Switch:

When the turn signal switch is turned to the left (  ) or right (  ), the corresponding turn signal blinks on and off.

To stop blinking, push the switch in.

### Horn Button:

When the horn button is pushed, the horn sounds.

### Passing Button:

When the passing button is pushed, the headlight high beam (passing beam) goes on to signal the driver of the vehicle ahead that you are about to pass him. The passing light shuts off as soon as the button is released.

### Hazard Switch:

If an emergency requires you to park on the highway shoulder, turn on the hazard lights to warn other drivers of your location.

Push in the hazard switch with the ignition switch in the ON or  position. All the turn signals and turn signal indicator lights will blink on and off.



***NOTICE***

**If you leave the switch on for a long time, the battery may become totally discharged. So be careful not to use the hazard lights for more than 30 minutes.**

**Brake/Clutch Lever Adjusters**

There is an adjuster on both the brake and clutch levers. Each adjuster has 5 positions so that the released lever position can be adjusted to suit the operator's hands. Push the lever forward and turn the adjuster to align the number with the mark on the lever holder.

The distance from the grip to the released lever is minimum at Number 5 and maximum at Number 1.

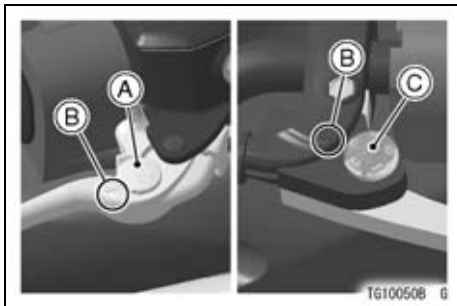

- A. Brake Lever Adjuster
- B. Mark
- C. Clutch Lever Adjuster

## Fuel Tank Cap

To open the fuel tank cap, pull up the key hole cover. Insert the ignition key into the fuel tank cap and turn the key clockwise.

To close the cap, push it down into place with the key inserted. The key can be removed by turning it counterclockwise to the original position. Close the key hole cover.

## NOTE

- *The fuel tank cap cannot be closed without the key inserted, and the key cannot be removed unless the cap is locked properly.*
- *Do not push on the key to close the cap, or the cap cannot be locked.*

## 42 GENERAL INFORMATION

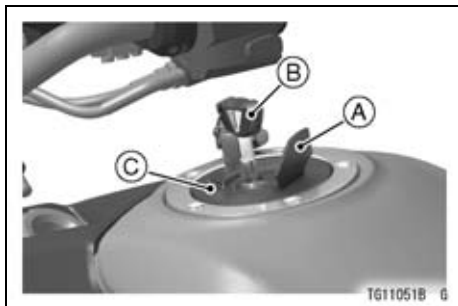

- A. Key Hole Cover
- B. Ignition Key
- C. Fuel Tank Cap

## Fuel Tank

The following octane rating gasoline is recommended for the fuel tank. Avoid filling the tank in the rain or where heavy dust is blowing so that the fuel does not get contaminated.

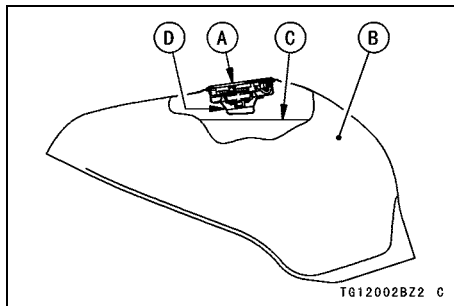

- A. Tank Cap
- B. Fuel Tank
- C. Top Level
- D. Filler Neck

 **WARNING**

Gasoline is extremely flammable and can be explosive under certain conditions, creating the potential for serious burns. Turn the ignition switch to “OFF”. Do not smoke. Make sure the area is well-ventilated and free from any source of flame or sparks; this includes any appliance with a pilot light. Never fill the tank completely to the top. If the tank is filled completely to the top, heat may cause the fuel to expand and overflow through the vents in the tank cap. After refueling, make sure the tank cap is closed securely. If gasoline is spilled on the fuel tank, wipe it off immediately.

**NOTICE**

California model only: Never fill the tank so the fuel level rises into the filler neck. If the tank is overfilled, heat may cause the fuel to expand and flow into the Evaporative Emission Control System resulting in hard starting and engine hesitation and in compliance with the emission regulation.

**Fuel Requirement***Fuel Type*

Use clean, fresh unleaded gasoline with a minimum Antiknock Index of 87. The Antiknock Index is posted on service station pumps. The octane rating of a gasoline is a measure of its resistance to detonation or “knocking.” The Antiknock Index is an average of the Research Octane Number (RON) and

#### 44 GENERAL INFORMATION

the Motor Octane Number (MON) as shown in the table.

Octane Rating Method	Minimum Rating
Antiknock Index $\frac{(\text{RON} + \text{MON})}{2}$	87

#### ***NOTICE***

**Use minimum of 87 octane gasoline only to prevent severe engine damage.**

#### ***NOTICE***

**If engine “knocking” or “pinging” occurs, use a different brand of gasoline of a higher octane rating. If this condition is allowed to continue it can lead to severe engine damage.**

**Gasoline quality is important. Fuels of low quality or not meeting standard industry specifications may result in unsatisfactory performance. Operating problems that result from the use of poor quality or nonrecommended fuel may not be covered under your warranty.**

### *Fuels Containing Oxygenates*

Gasoline frequently contains oxygenates (alcohols and ethers) especially in areas of the U.S. and Canada which are required to sell such reformulated fuels as part of a strategy to reduce exhaust emissions.

The types and volume of fuel oxygenates approved for use in unleaded gasoline by the U.S. Environmental Protection Agency include a broad range of alcohols and ethers, but only two components have seen any significant level of commercial use.

**Gasoline/Alcohol Blends** - Gasoline containing up to 10% ethanol (alcohol produced from agricultural products such as corn), also known as "gasohol" is approved for use.

## **NOTICE**

**Avoid using blends of unleaded gasoline and methanol (wood alcohol) whenever possible, and never use "gasohol" containing more than 5% methanol. Fuel system damage and performance problems may result.**

**Gasoline/Ether Blends** - The most common ether is methyl tertiary butyl ether (MTBE). You may use gasoline containing up to 15% MTBE.

## **NOTE**

- *Other oxygenates approved for use in unleaded gasoline include TAME (up to 16.7%) and ETBE (up to 17.2%). Fuel containing these oxygenates can also be used in your Kawasaki.*

## ***NOTICE***

Never use gasoline with an octane rating lower than the minimum specified by Kawasaki.

Never use “gasohol” with more than 10% ethanol, or more than 5% methanol. Gasoline containing methanol must also be blended with cosolvents and corrosion inhibitors.

Certain ingredients of gasoline may cause paint fading or damage. Be extra careful not to spill gasoline or gasoline oxygenate blends during refueling.

When not operating your Kawasaki for 30 to 60 days, mix a fuel stabilizer (such as STA-BIL) with the gasoline in the fuel tank. Fuel stabilizer additives inhibit oxidation of the fuel which minimizes gummy deposits.

## ***NOTICE***

Never store this product with “gasohol” in the fuel system. Before storage it is recommended that you drain all fuel from the fuel system. See the Storage section in this manual.

## Stand

The motorcycle is equipped with a side stand.

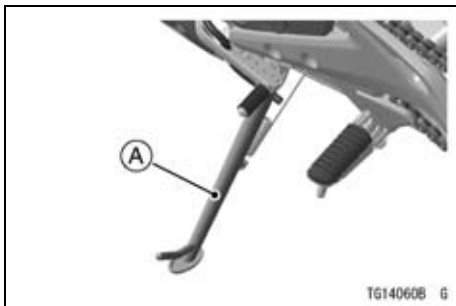

A. Side Stand

Do not sit on the motorcycle while it is on its side stand. Always kick the stand fully up before sitting on the motorcycle.

## NOTE

- *The motorcycle is equipped with a side stand switch. This switch is designed so that the engine does not start if the transmission is in gear and the side stand is down.*

## NOTE

- *When using the side stand, turn the handlebar to the left.*



## Seats

### *Passenger's Seat Removal*

- Insert the ignition key into the seat lock, and turn it clockwise.
- Remove the passenger's seat by pulling up the front of seat while turning the ignition key.

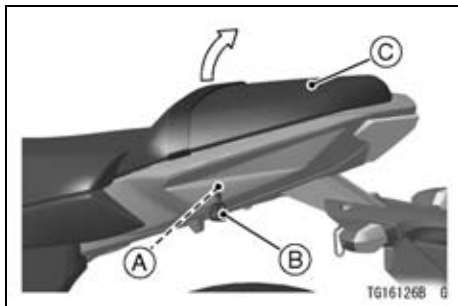

- A. Seat Lock
- B. Ignition Key
- C. Passenger's Seat

### *Rider's Seat Removal*

- Remove the passenger's seat.
- Slide the rider's seat rearward then pull the front of seat upward to remove it.

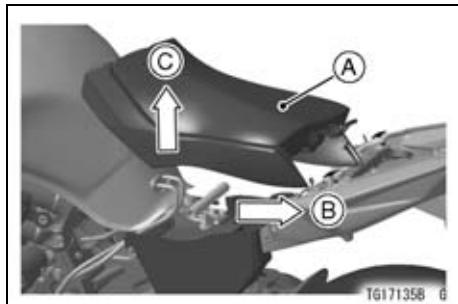

- A. Rider's Seat
- B. Slide Seat Rearward
- C. Pull Seat Upward

### *Rider's Seat Installation*

- Slide the rider's seat rearward to position it on the frame.

- Slide the rider's seat forward to engage the tab under the seat with the bracket on the frame.

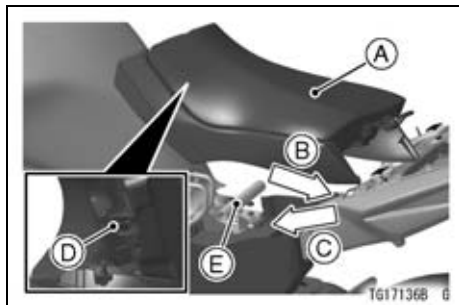

- A. Rider's Seat
- B. Slide Seat Rearward
- C. Slide Seat Forward
- D. Tab
- E. Bracket

### *Passenger's Seat Installation*

- Insert the tab under the passenger's seat into the hole in the frame.

- Insert the lock plate of the passenger's seat into the slot on the frame while aligning the projection with the hole on the frame.

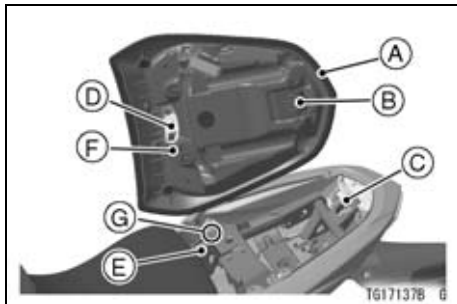

- A. Passenger's Seat
- B. Tab
- C. Hole
- D. Lock Plate
- E. Slot
- F. Projections
- G. Hole

## 50 GENERAL INFORMATION

- Push down the front part of the passenger's seat until the lock clicks.
- Pull up the front and rear ends of the passenger's seat to make sure they are securely locked.

### Helmet Hooks

Helmets can be secured to the motorcycle by the helmet hooks located under the passenger's seat.

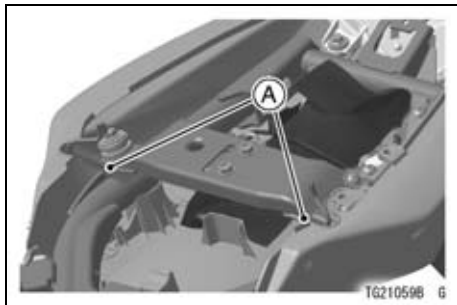

A. Helmet Hooks

**⚠ WARNING**

Riding with helmets attached to the hooks could cause an accident by distracting the operator or interfering with normal vehicle operation. Do not ride the motorcycle with helmets attached to the hooks.

**Tool Kit**

The tool kit is located under the passenger's seat.

The kit contains tools that are helpful in making roadside repairs, adjustments, and some maintenance procedures explained in this manual. Keep the tool kit in the original place.

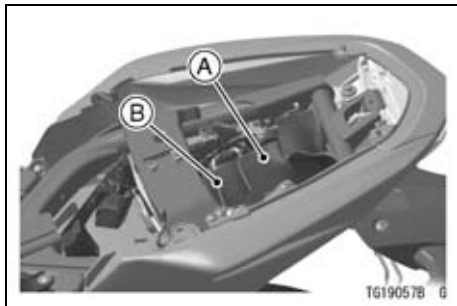

**A. Tool Kit**

**B. Band**

## Tying Hooks

When tying up light loads to the passenger's seat, use the tying hooks located on the left and right sides of the rear fender.

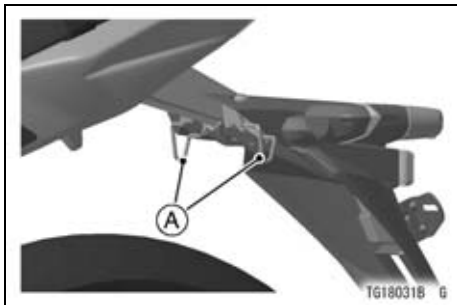

A. Tying Hooks

## Windshield

The windshield can be adjusted within 3 positions in height to suit the rider's preference.

- Remove the four bolts and windshield.

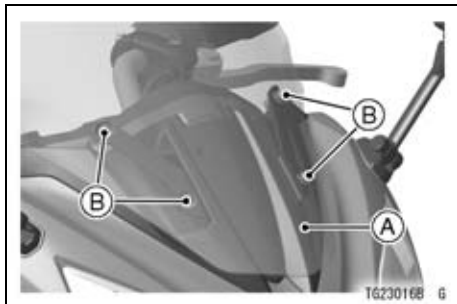

A. Windshield

B. Bolts and Nylon Washers

- Remove the windshield bracket mounting bolts.

- Reinstall the removed parts in the windshield positions to suit the rider's preference.

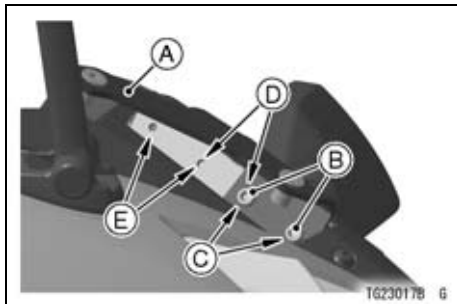

- A. Windshield Bracket**
- B. Bolts**
- C. Low Position**
- D. Middle Position**
- E. High Position**

---

**BREAK-IN**

---

The first 1 600 km (1 000 mi) that the motorcycle is ridden is designated as the break-in period. If the motorcycle is not used carefully during this period, you may very well end up with a “broken down” instead of a “broken in” motorcycle after a few thousand kilometers.

The following rules should be observed during the break-in period.

- The table shows maximum recommended engine speed during the break-in period.

Distance traveled	Maximum engine speed
0 ~ 800 km (0 ~ 500 mi)	4 000 r/min (rpm)
800 ~ 1 600 km (500 ~ 1 000 mi)	6 000 r/min (rpm)

**NOTE**

- *When operating on public roadways, keep maximum speed under traffic law limits.*
- Do not start moving or race the engine immediately after starting it, even if the engine is already warm. Run the engine for two or three minutes at idle speed to give the oil a chance to work up into all the engine parts.
- Do not race the engine while the transmission is in neutral.

 **WARNING**

**New tires are slippery and may cause loss of control and injury. A break-in period of 160 km (100 miles) is necessary to establish normal tire traction. During break-in, avoid sudden and maximum braking and acceleration, and hard cornering.**

In addition to the above, at 1 000 km (600 mi) it is extremely important that the owner have the initial maintenance service performed by a competent mechanic following the procedures in the Service Manual.



---

## HOW TO RIDE THE MOTORCYCLE

---

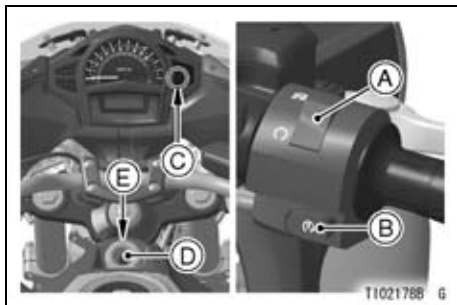

### Starting the Engine

- Check that the engine stop switch is in the  position.
- Turn the ignition key to “ON”.
- Make sure the transmission is in neutral.
- Without holding the throttle grip, push the starter button to start the engine.



- A. Engine Stop Switch
- B. Starter Button
- C. Neutral Indicator Light
- D. Ignition Switch
- E. ON position

**NOTE**

- *The engine warning indicator light (  ) may stay on for a few seconds. However, as long as it goes off soon, there is no problem with the motorcycle riding.*
- *While the engine is cold, the fast idle system automatically raises the engine idling speed. At this time, the engine warning indicator light (  ) may go on if you operate the throttle grip unnecessarily.*
- *The motorcycle is equipped with a vehicle-down sensor which causes the engine to stop automatically if the motorcycle falls down. The engine warning indicator light (  ) blinks when the starter button pressed if the engine cannot be started. After righting the motorcycle, first turn the ignition key to “OFF” and then back to “ON” before starting the engine.*

**NOTICE**

**Do not operate the starter continuously for more than 5 seconds, or the starter will overheat and the battery power will drop temporarily. Wait 15 seconds between each operation of the starter to let it cool and the battery power recover.**

**NOTE**

- *The motorcycle is equipped with a starter lockout switch. This switch is designed so that the engine does not start if the transmission is in gear and the side stand is down. However, the engine can be started if the clutch lever is pulled and the side stand is fully up.*

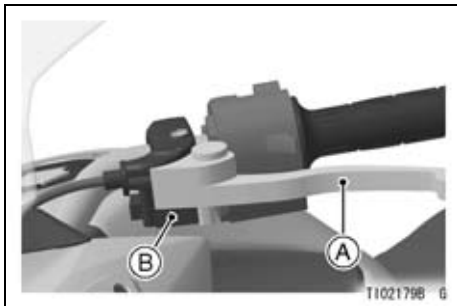

- A. Clutch Lever
- B. Starter Lockout Switch

## Jump Starting

If your motorcycle battery is “run down,” it should be removed and charged. If this is not practical, a 12 volt booster battery and jumper cables may be used to start the engine.

### ***NOTICE***

**Do not let the engine idle longer than five minutes, or engine overheating and damage may occur.**

**⚠ DANGER**

Battery acid generates hydrogen gas which is flammable and explosive under certain conditions. It is present within a battery at all times, even in a discharged condition. Keep all flames and sparks (cigarettes) away from the battery. Wear eye protection when working with a battery. In the event of battery acid contact with skin, eyes, or clothing, wash the affected areas immediately with water for at least five minutes. Seek medical attention.

*Connecting Jumper Cables*

- Remove the passenger's seat and rider's seat.
- Make sure the ignition key is turned to OFF.

- Connect a jumper cable from the positive (+) terminal of the booster battery to the positive (+) terminal of the motorcycle battery.

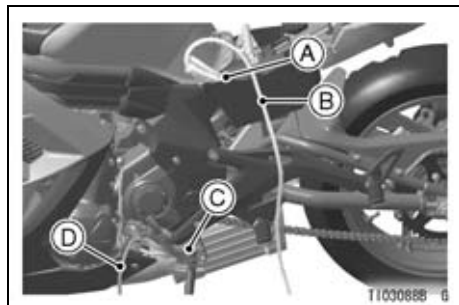

- A. Motorcycle Battery Positive (+) Terminal
- B. From Booster Battery Positive (+) Terminal
- C. Shift Pedal
- D. From Booster Battery Negative (-) Terminal

- Connect another jumper cable from the negative (-) terminal of the booster battery to shift pedal or other

unpainted metal surface on your motorcycle. Do not use the negative (-) terminal of the battery.

**⚠ DANGER**

**Batteries contain sulfuric acid that can cause burns and produce hydrogen gas which is highly explosive. Do not make this last connection at the fuel system or battery. Take care not to touch the positive and negative cables together, and do not lean over the battery when making this last connection. Do not connect to a frozen battery. It could explode. Do not reverse polarity by connecting positive (+) to negative (-), or a battery explosion and serious damage to the electrical system may occur.**

- Follow the standard engine starting procedure.

**NOTICE**

**Do not operate the starter continuously for more than 5 seconds or the starter will overheat and the battery power will drop temporarily. Wait 15 seconds between each operation of the starter to let it cool and the battery power recover.**

- After the engine has started, disconnect the jumper cables. Disconnect the negative (-) cable from the motorcycle first.
- Reinstall the removed parts.

## Moving Off

- Check that the side stand is up.
- Pull in the clutch lever.
- Shift into 1st gear.
- Open the throttle a little, and start to let out the clutch lever very slowly.
- As the clutch starts to engage, open the throttle a little more, giving the engine just enough fuel to keep it from stalling.

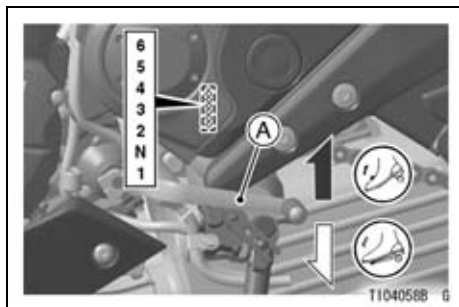

A. Shift Pedal

## NOTE

- *The motorcycle is equipped with a side stand switch. This switch is designed so that the engine does not start if the transmission is in gear and the side stand is down.*
- *When the headlight is on high beam, two headlight beams go on, and on low beam, one headlight goes on.*

## Shifting Gears

- Close the throttle while pulling in the clutch lever.
- Shift into the next higher or lower gear.
- Open the throttle part way, while releasing the clutch lever.
- For smooth riding, each gear position should cover the proper rate of speed shown in the table.

### **WARNING**

**Downshifting to a lower gear at high speed causes engine rpm to increase excessively, potentially damaging the engine and it may also cause the rear wheel to skid and cause an accident. Downshifting should be done below the vehicle speeds for each gear shown in the table.**

**Vehicle speed when shifting**

Shifting up	km/h (mph)	Shifting down	km/h (mph)
1st → 2nd	15 ( 9)	6th → 5th	30 (19)
2nd → 3rd	25 (15)	5th → 4th	25 (15)
3rd → 4th	35 (21)	4th → 3rd	20 (12)
4th → 5th	45 (27)	3rd → 2nd	15 ( 9)
5th → 6th	55 (34)	2nd → 1st	15 ( 9)

**NOTE**

- *The transmission is equipped with a positive neutral finder. When the motorcycle is standing still, the transmission cannot be shifted past neutral from 1st gear. To use the positive neutral finder, shift down to 1st gear, then lift up on the shift pedal while standing still. The transmission will shift only into neutral.*



### Braking

- Close the throttle completely, leaving the clutch engaged (except when shifting gears) so that the engine will help slow down the motorcycle.
- Shift down one gear at a time so that you are in 1st gear when you come to a complete stop.
- When stopping, always apply both brakes at the same time. Normally the front brake should be applied a little more than the rear. Shift down or fully disengage the clutch as necessary to keep the engine from stalling.
- Never lock the brakes, or it will cause the tires to skid. When turning a corner, it is better not to brake at all. Reduce your speed before you get into the corner.
- For emergency braking, disregard downshifting, and concentrate on

applying the brakes as hard as possible without skidding.

- Even in motorcycles equipped with ABS, braking during cornering may cause wheel slip. When turning a corner, it is better to limit braking to the light application of both brakes or not to brake at all. Reduce your speed before you get into the corner.

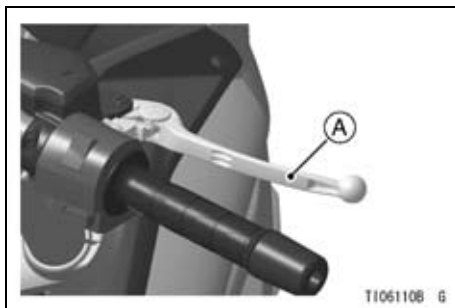

A. Front Brake Lever

## Anti-lock Brake System (ABS) for models equipped with ABS

ABS is designed to help prevent the wheels from locking up when hard brakes are applied while running straight. The ABS automatically regulates brake force. Intermittently gaining gripping force and braking force helps prevent wheel lock-up and allows stable steering control while stopping.

Brake control function is identical to that of a conventional motorcycle. The brake lever is used for the front brake and the brake pedal for the rear brake.

Although the ABS provides stability while stopping by preventing wheel lock-up, remember the following characteristics:

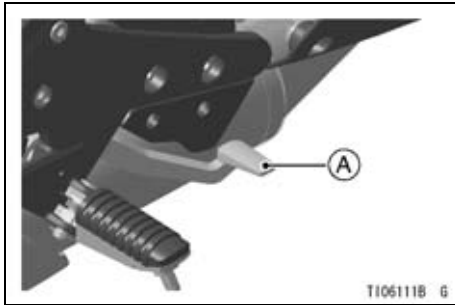

A. Rear Brake Pedal

## 66 HOW TO RIDE THE MOTORCYCLE

- ABS cannot compensate for adverse road conditions, misjudgement or improper application of brakes. You must take the same care as with motorcycles not equipped with ABS.
- ABS is not designed to shorten the braking distance. On loose, uneven or downhill surfaces, the stopping distance of a motorcycle with ABS may be longer than that of an equivalent motorcycle without ABS. Use special caution in such areas.
- ABS will help prevent wheel lock-up during straight-up braking, but it cannot control wheel slip which may be caused by braking during cornering. When turning a corner, it is better to limit braking to the light application of both brakes or not to brake at all. Reduce your speed before you get into the corner.

- The computers integrated in the ABS compare vehicle speed with wheel speed. Since non-recommended tires can affect wheel speed, they may confuse the computers, which can extend braking distance.

### **WARNING**

**ABS cannot protect the rider from all possible hazards and is not a substitute for safe riding practices. Be aware of how the ABS system operates and its limitations. It is the rider's responsibility to ride at appropriate speeds and manner for weather, road surface and traffic conditions.**

 **WARNING**

Use of non-recommended tires may cause malfunctioning of ABS and can lead to extended braking distance. The rider could have an accident as a result. Always use recommended standard tires for this motorcycle.

**NOTE**

- *When the ABS is functioning, you may feel a pulsing in the brake lever or pedal. This is normal. You need not suspend applying brakes.*
- *ABS does not function at the speed of approx. 6 km/h or below.*
- *ABS does not function if the battery is discharged.*

- *ABS indicator light may go on under motorcycle riding condition. (ex. The front or rear wheel races.) In this case, first turn the ignition key to "OFF", and then back to "ON". ABS indicator light goes off by this operation, but if ABS indicator light stays on after the motorcycle runs at the speed of approx. 6 km/h or below, you should have the ABS checked by an authorized Kawasaki dealer.*

**Yellow ABS Indicator Light:**

Normally the ABS indicator light goes on when the ignition switch is turned on and goes off shortly after the motorcycle starts moving.

If the indicator light shows any of the following, a fault or faults may have taken place in the ABS. You should have the ABS checked by an authorized Kawasaki dealer.

## 68 HOW TO RIDE THE MOTORCYCLE

- The light does not go on when the ignition switch is turned on.
- The light stays on lit after the motorcycle starts moving.
- The light goes on and stays on after the motorcycle starts moving.

Remember that the ABS does not function when the indicator light is on, but if the ABS fails, the conventional brake system still works normally.

### Stopping the Engine

- Close the throttle completely.
- Shift the transmission into neutral.
- Turn the ignition key to “OFF”.
- Support the motorcycle on a firm, level surface with the side stand.
- Lock the steering.

### NOTE

- *The motorcycle is equipped with a vehicle-down sensor which causes the engine to stop automatically if the motorcycle falls down. The engine warning indicator light (  ) blinks when the starter button pressed if the engine cannot be started. After righting the motorcycle, first turn the ignition key to “OFF” and then back to “ON” before starting the engine.*

## Stopping the Motorcycle in an Emergency

Your Kawasaki Motorcycle has been designed and manufactured to provide you optimum safety and convenience. However, in order to fully benefit from Kawasaki's safety engineering and craftsmanship, it is essential that you, the owner and operator, properly maintain your motorcycle and become thoroughly familiar with its operation. Improper maintenance can create a dangerous situation known as throttle failure. Two of the most common causes of throttle failure are:

1. An improperly serviced or clogged air cleaner may allow dirt and dust to enter the throttle body and stick the throttle open.
2. During removal of the air cleaner, dirt is allowed to enter and jam the fuel injection system.

In an emergency situation such as throttle failure, your vehicle may be stopped by applying the brakes and disengaging the clutch. Once this stopping procedure is initiated, the engine stop switch may be used to stop the engine. If the engine stop switch is used, turn off the ignition switch after stopping the motorcycle.

## Parking

### **WARNING**

Operating or parking the vehicle near flammable materials can cause a fire, and can result in property damage or severe personal injury.

Do not idle or park your vehicle in an area where tall or dry vegetation, or other flammable materials could come into contact with the muffler or exhaust pipe.

### **WARNING**

The engine and exhaust system get extremely hot during normal operation and can cause serious burns.

Never touch a hot engine, exhaust pipe, or muffler during operation or after stopping the engine.

- Shift the transmission into neutral and turn the ignition key to “OFF”.
- Support the motorcycle on a firm, level surface with the side stand.

### ***NOTICE***

Do not park on a soft or steeply inclined surface, or the motorcycle may fall over.

- If parking inside a garage or other structure, be sure it is well ventilated and the motorcycle is not close to any source of flame or sparks; this includes any appliance with a pilot light.

 **WARNING**

**Gasoline is extremely flammable and can be explosive under certain conditions, creating the potential for serious burns. Turn the ignition switch to “OFF”. Do not smoke. Make sure the area is well ventilated and free from any source of flame or sparks; this includes any appliance with a pilot light.**

- Lock the steering to prevent theft.

**NOTE**

- *When stopping near traffic at night, you can leave the turn signals blinking for greater visibility by turning the ignition key to the  position and push in the hazard switch.*



## Catalytic Converter

This motorcycle is equipped with a catalytic converter in the exhaust system. The converter reacts with carbon monoxide, hydrocarbons and nitrogen oxides to convert them into carbon dioxide, water, nitrogen and oxygen resulting in much cleaner exhaust gases to be discharged into the atmosphere.

For proper operation of the catalytic converter, the following cautions must be observed.

### **WARNING**

**Operating or parking the vehicle near flammable materials can cause a fire, and can result in property damage or severe personal injury.**

**Do not idle or park your vehicle in an area where tall or dry vegetation, or other flammable materials could come into contact with the muffler or exhaust pipe.**

### **WARNING**

**The engine and exhaust system get extremely hot during normal operation and can cause serious burns.**

**Never touch a hot engine, exhaust pipe, or muffler during operation or after stopping the engine.**

- Use only unleaded gasoline. Never use leaded gasoline. Leaded gasoline significantly reduces the capability of the catalytic converter.
- Do not operate the vehicle with the engine or any one cylinder misfiring. Under these conditions unburned

air/fuel mixture flowing out of engine excessively accelerates reaction in the converter allowing the converter to overheat and become damaged when the engine is hot, or reduces converter performance when the engine is cold.

---

## SAFE OPERATION

---

### Safe Riding Technique

The points given below are applicable for everyday motorcycle use and should be carefully observed for safe and effective vehicle operation.

**For safety, eye protection and a helmet are strongly recommended. You should be aware of and verify the applicable safety regulations in force prior to riding your motorcycle. Gloves and suitable footwear should also be used for added protection in case of a mishap.**

**A motorcycle does not provide the impact protection of an automobile, so defensive riding in addition to wearing protective apparel is extremely important. Do not let protective apparel give you a false sense of security.**

**When riding always keep both hands on the handlebars and both feet on the footpegs. Removing your hands from the handlebars or feet from the footpegs while riding can be hazardous. If you remove even one hand or foot, you can reduce your ability to control the motorcycle.**

**Before changing lanes, look over your shoulder to make sure the way is clear. Do not rely solely on the rear view mirror; you may misjudge a vehicle's distance and speed, or you may not see it at all.**

**In general your actions should be smooth as sudden acceleration, braking or turning may cause loss of control, especially when riding in wet conditions or on loose roadway surfaces, when the ability to maneuver will be reduced.**

**When going up steep slopes, shift to a lower gear so that there is plenty of power to spare rather than overloading the engine.**

**When applying the brakes, use both the front and rear brakes. Applying only one brake for sudden braking may cause the motorcycle to skid and lose control.**

**When going down long slopes, control vehicle speed by closing the throttle. Use the front and rear brakes for auxiliary braking.**

**In wet conditions, rely more on the throttle to control vehicle speed and less on the front and rear brakes. The throttle should also be used judiciously to avoid skidding the rear wheel from too rapid acceleration or deceleration.**

**Riding at the proper rate of speed and avoiding unnecessarily fast acceleration are important not only for safety and low fuel consumption but also for long vehicle life and quieter operation.**

**On rough roads, exercise caution, slow down, and grip the fuel tank with the knees for better stability.**

**When quick acceleration is necessary as in passing, shift to a lower gear to obtain the necessary power.**

## **76 SAFE OPERATION**

**Do not downshift at too high an r/min (rpm) to avoid damage from overrevving to the engine.**

**Avoiding unnecessary weaving is important to the safety of both the rider and other motorists.**

## Daily Checks

Check the following items each day before you ride. The time required is minimal, and habitual performance of these checks will help ensure you a safe, reliable ride.

If any irregularities are found during these checks, refer to the Maintenance and Adjustment chapter or see your dealer for the action required to return the motorcycle to a safe operating condition.

### **WARNING**

**Failure to perform these checks before operation may result in serious damage or an accident. Always perform daily checks before operation.**

### **DANGER**

**Exhaust gas contains carbon monoxide, a colorless, odorless poisonous gas.**

**Inhaling carbon monoxide can cause serious brain injury or death.**

**Do not run the engine in enclosed areas. Operate only in a well-ventilated area.**

- |                  |                                    |
|------------------|------------------------------------|
| Fuel .....       | Adequate supply in tank, no leaks. |
| Engine oil ..... | Oil level between level lines.     |
| Tires .....      | Air pressure (when cold):          |

## 78 SAFE OPERATION

Front	Up to 200 kg (441 lb) Load	225 kPa (2.25 kgf/cm <sup>2</sup> , 32 psi)
Rear	Up to 200 kg (441 lb) Load	250 kPa (2.50 kgf/cm <sup>2</sup> , 36 psi)

- Install the air valve cap.
- Drive chain ..... Slack 25 ~ 35 mm (1.0 ~ 1.4 in.)  
Lubricate the drive chain if dry.
- Nuts, bolts, fasteners .. Check that steering and suspension components, axles, and all controls are properly tightened or fastened.
- Steering ..... Action smooth but not loose from lock to lock.  
No binding of control cables.
- Brakes ..... Brake pad wear: Lining thickness more than 1 mm (0.04 in.) left.  
No brake fluid leakage.
- Throttle ..... Throttle grip play 2 ~ 3 mm (0.08 ~ 0.12 in.).
- Clutch ..... Clutch lever play 2 ~ 3 mm (0.08 ~ 0.12 in.).  
Clutch lever operates smoothly.
- Coolant ..... No coolant leakage.  
Coolant level between level lines (when engine is cold).
- Electrical equipment ... All lights (Headlight, Tail/Brake Lights, Turn Signal Lights, Warning/Indicator Lights) and horn work.
- Engine stop switch ..... Stops engine.

Side stand ..... Returns to its fully up position by spring tension.  
Returns spring not weak or not damaged.





## Additional Considerations for High Speed Operation

**Brakes:** The importance of the brakes, especially during high speed operation, cannot be overemphasized. Check to see that they are correctly adjusted and functioning properly.

**Steering:** Looseness in the steering can cause loss of control. Check to see that the handlebar turns freely but has no play.

**Tires:** High speed operation is hard on tires, and good tires are crucial for riding safety. Examine their overall condition, inflate them to the proper pressure, and check the wheel balance.

**Fuel:** Have sufficient fuel for the high fuel consumption during high speed operation.

**Engine Oil:** To avoid engine seizure and resulting loss of control, make sure that the oil level is at the upper level line.

**Coolant:** To avoid overheating, check that the coolant level is at the upper level line.

**Electrical Equipment:** Make sure that the headlight, tail/brake light, turn signals, horn, etc., all work properly.

**Miscellaneous:** Make sure that all nuts and bolts are tight and that all safety related parts are in good condition.

 **WARNING**

**Handling characteristics of a motorcycle at high speeds may vary from those you are familiar with at legal highway speeds. Do not attempt high speed operation unless you have received sufficient training and have the required skills.**

---

## MAINTENANCE AND ADJUSTMENT

---

The maintenance and adjustments outlined in this chapter must be carried out and must be done in accordance with the Periodic Maintenance Chart to keep the motorcycle in good running condition. **The initial maintenance is vitally important and must not be neglected.**

With a basic knowledge of mechanics and the proper use of tools, you should be able to carry out many of the maintenance items described in this chapter. If you lack proper experience or doubt your ability, all adjustments, maintenance, and repair work should be completed by a qualified technician.

Please note that Kawasaki cannot assume any responsibility for damage resulting from incorrect or improper adjustment done by the owner.

## EMISSION CONTROL INFORMATION

To protect the environment in which we all live, Kawasaki has incorporated crankcase emission (1), exhaust emission (2) control systems in compliance with applicable regulations of the United States Environmental Protection Agency and California Air Resources Board. Additionally, Kawasaki has incorporated an evaporative emission control system (3) in compliance with applicable regulations of the United States Environmental Protection Agency.

### 1. Crankcase Emission Control System

This system eliminates the release of crankcase vapors into the atmosphere. Instead, the vapors are routed through an oil separator to the intake side of the engine. While the engine is operating, the vapors are drawn into the combustion chamber, where they are burned along with the fuel and air supplied by the fuel injection system.

### 2. Exhaust Emission Control System

This system reduces the amount of pollutants discharged into the atmosphere by the exhaust of this motorcycle. The fuel, ignition and exhaust systems of this motorcycle have been carefully designed and constructed to ensure an efficient engine with low exhaust pollutant levels. The exhaust system of this model motorcycle includes a catalytic converter system.

## **84 MAINTENANCE AND ADJUSTMENT**

### **3. Evaporative Emission Control System**

The evaporative emission control system for this vehicle consists of low permeation fuel hoses and fuel tank.

### **3. Evaporative Emission Control System (California model only)**

Vapors caused by fuel evaporation in the fuel system are not vented into the atmosphere. Instead, fuel vapors are routed into the running engine to be burned, or stored in a canister when the engine is stopped.

### **High Altitude Performance Adjustment Information**

High altitude adjustment is not required.

## MAINTENANCE AND WARRANTY

Proper maintenance is necessary to ensure that your motorcycle will continue to have low emission levels. This Owner's Manual contains those maintenance recommendations for your motorcycle. Those items identified by the Periodic Maintenance Chart are necessary to ensure compliance with the applicable standards.

As the owner of this motorcycle, you have the responsibility to make sure that the recommended maintenance is carried out according to the instructions in this Owner's Manual at your own expense.

The Kawasaki Limited Emission Control System Warranty requires that you return your motorcycle to an authorized Kawasaki dealer for remedy under warranty. Please read the warranty carefully, and keep it valid by complying with the owner's obligations it contains.

You should keep a maintenance record for your motorcycle. To assist you in keeping this record, we have provided space on pages 178 through 185 of this manual where an authorized Kawasaki dealer, or someone equally competent, can record the maintenance. You should also retain copies of maintenance work orders, bills, etc., as verification of this maintenance.

## **TAMPERING WITH NOISE CONTROL SYSTEM PROHIBITED:**

Federal law prohibits the following acts or the causing thereof: (1) the removal or rendering inoperative by any person other than for purposes of maintenance, repair, or replacement, of any device or element of design incorporated into any new vehicle for the purpose of noise control prior to its sale or delivery to the ultimate purchaser or while it is in use, or (2) the use of the vehicle after such device or element of design has been removed or rendered inoperative by any person.

Among those acts presumed to constitute tampering are the acts listed below:

- \* Replacement of the original exhaust system or muffler with a component not in compliance with Federal regulations.
- \* Removal of the muffler(s) or any internal portion of the muffler(s).
- \* Removal of the air box or air box cover.
- \* Modifications to the muffler(s) or air intake system by cutting, drilling, or other means if such modifications result in increased noise levels.

## Periodic Maintenance Chart

K: Should be serviced by an authorized Kawasaki dealer.

\*: For higher odometer readings, repeat at the frequency interval established here.

#: Service more frequently when operating in severe conditions: dusty, wet, muddy, high speed, or frequent starting/stopping.

(e): Emission Related Item

### 1. Periodic Inspection (Engine Related Items)

Frequency	Whichever comes first ↓	*Odometer Reading km × 1 000 (mile × 1 000)							See Page
		1 (0.6)	6 (3.75)	12 (7.5)	18 (11.25)	24 (15)	30 (18.75)	36 (22.5)	
Operation (Engine Items)	Every								
Valve clearance - inspect (e)						•			116
Throttle control system (play, smooth return, no drag) - inspect (e)	year	•		•		•		•	118



## 88 MAINTENANCE AND ADJUSTMENT

Frequency	Whichever comes first ↓ Every	*Odometer Reading km × 1 000 (mile × 1 000)							See Page
		1 (0.6)	6 (3.75)	12 (7.5)	18 (11.25)	24 (15)	30 (18.75)	36 (22.5)	
Engine vacuum synchronization - inspect				•		•		•	121
Idle speed - inspect (e)		•		•		•		•	121
<b>K</b> Fuel leak (fuel hose and pipe) - inspect	year	•		•		•		•	—
<b>K</b> Fuel hoses damage - inspect	year	•		•		•		•	—
<b>K</b> Fuel hoses installation condition - inspect	year	•		•		•		•	—

Frequency	Operation (Engine Items)	Whichever comes first →							*Odometer Reading km × 1 000 (mile × 1 000)	See Page
		Every	1 (0.6)	6 (3.75)	12 (7.5)	18 (11.25)	24 (15)	30 (18.75)		
	Coolant level - inspect		•		•		•		•	107
	Coolant leak - inspect	year	•		•		•		•	105
	Radiator hoses damage - inspect	year	•		•		•		•	105
	Radiator hoses installation condition - inspect	year	•		•		•		•	105

## 90 MAINTENANCE AND ADJUSTMENT

Frequency  Operation (Engine Items)	Whichever comes first →								See Page
	↓ Every	*Odometer Reading km × 1 000 (mile × 1 000)							
		1 (0.6)	6 (3.75)	12 (7.5)	18 (11.25)	24 (15)	30 (18.75)	36 (22.5)	
Evaporative emission control system - function (California model only) (e)		•	•	•	•	•	•	•	114
Air suction system damage - inspect (e)				•		•		•	115

## 2. Periodic Inspection (Chassis Related Items)



Frequency	Whichever comes first ↓	*Odometer Reading km × 1000 (mile × 1000)							See Page
		→	1 (0.6)	6 (3.75)	12 (7.5)	18 (11.25)	24 (15)	30 (18.75)	
Operation (Chassis Items)	Every								
<b>Clutch and drive train:</b>									
Clutch operation (play, engagement, disengagement) - inspect		•		•		•		•	123
Drive chain lubrication condition - inspect #		every 600 km (400 mile)							131
Drive chain slack - inspect #		every 1 000 km (600 mile)							125
Drive chain wear - inspect #				•		•		•	129

## 92 MAINTENANCE AND ADJUSTMENT

Frequency	Operation (Chassis Items)	*Odometer Reading km × 1000 (mile × 1000)							See Page
		1 (0.6)	6 (3.75)	12 (7.5)	18 (11.25)	24 (15)	30 (18.75)	36 (22.5)	
	<b>K</b> Drive chain guide wear - inspect			•		•		•	–
<b>Wheels and tires:</b>									
	Tire air pressure - inspect	year		•		•		•	144
	Wheels/tires damage - inspect			•		•		•	145
	Tire tread wear, abnormal wear - inspect			•		•		•	145
	<b>K</b> Wheel bearings damage - inspect	year		•		•		•	–



## 94 MAINTENANCE AND ADJUSTMENT

Frequency	Whichever comes first  								See Page
	Operation (Chassis Items)	*Odometer Reading km × 1000 (mile × 1000)							
Every	1 (0.6)	6 (3.75)	12 (7.5)	18 (11.25)	24 (15)	30 (18.75)	36 (22.5)		
Brake operation (effectiveness, play, drag) - inspect	year	•	•	•	•	•	•	•	135
Brake light switch operation - inspect		•	•	•	•	•	•	•	136
<b>Suspensions:</b>									
Front forks/rear shock absorber operation (damping and smooth stroke) - inspect				•		•		•	139, 140

Frequency	Whichever comes first →								See Page
	↓	*Odometer Reading km × 1000 (mile × 1000)							
Operation (Chassis Items)	Every	1 (0.6)	6 (3.75)	12 (7.5)	18 (11.25)	24 (15)	30 (18.75)	36 (22.5)	
Front forks/rear shock absorber oil leak - inspect	year			•		•		•	139, 140
<b>Steering System:</b>									
<b>K</b> Steering play - inspect	year	•		•		•		•	–
<b>K</b> Steering stem bearings - lubricate	2 years					•			–
<b>Electrical System:</b>									
Lights and switches operation - inspect	year			•		•		•	–



## 96 MAINTENANCE AND ADJUSTMENT

Frequency	Operation (Chassis Items)	*Odometer Reading km × 1000 (mile × 1000)							See Page	
		Whichever comes first ↓	1 (0.6)	6 (3.75)	12 (7.5)	18 (11.25)	24 (15)	30 (18.75)		36 (22.5)
	Headlight aiming - inspect	Every year			•		•		•	153
	Side stand switch operation - inspect	year			•		•		•	–
	Engine stop switch operation - inspect	year			•		•		•	–
<b>Chassis:</b>										
	Chassis parts - lubricate	year			•		•		•	157
	Bolts and nuts tightness - inspect		•		•		•		•	164

## 3. Periodic Replacement

Change/Replacement Items	Frequency	*Odometer Reading km × 1 000 (mile × 1 000)					See Page
	Whichever comes first ↓ Every	1 (0.6)	12 (7.5)	24 (15)	36 (22.5)	48 (30)	
Air cleaner element - replace # (e)	every 18 000 km (11 250 mile)					117	
Engine oil - change #	year	●	●	●	●	●	101
Oil filter - replace	year	●	●	●	●	●	101
<b>K</b> Fuel hoses - replace	5 years						–
<b>K</b> Coolant - change	3 years				●		112
<b>K</b> Radiator hoses and O-rings - replace	3 years				●		–
<b>K</b> Brake hoses - replace	4 years					●	–
<b>K</b> Brake fluid (front and rear) - change	2 years			●		●	135

## 98 MAINTENANCE AND ADJUSTMENT

Change/Replacement Items	Frequency	*Odometer Reading km × 1 000 (mile × 1 000)					See Page
	Whichever comes first ↓ Every	1 (0.6)	12 (7.5)	24 (15)	36 (22.5)	48 (30)	
<b>K</b> Rubber parts of master cylinder and caliper - replace	4 years					●	–
Spark plug - replace (e)			●	●	●	●	113

## Engine Oil

In order for the engine, transmission, and clutch to function properly, maintain the engine oil at the proper level, and change the oil and replace the oil filter in accordance with the Periodic Maintenance Chart. Not only do dirt and metal particles collect in the oil, but the oil itself loses its lubricative quality if used too long.

### WARNING

**Motorcycle operation with insufficient, deteriorated, or contaminated engine oil will cause accelerated wear and may result in engine or transmission seizure, accident, and injury. Check the oil level before each ride and change the oil according to the periodic maintenance chart in the owner's manual.**

### *Oil Level Inspection*

- If the oil has just been changed, start the engine and run it for several minutes at idle speed. This fills the oil filter with oil. Stop the engine, then wait several minutes until the oil settles.

### **NOTICE**

**Racing the engine before the oil reaches every part can cause engine seizure.**

- If the motorcycle has just been used, wait several minutes for all the oil to drain down.
- Check the engine oil level through the oil level inspection window. With the motorcycle held level, the oil level should come up between the upper and lower level lines next to the oil level inspection window.

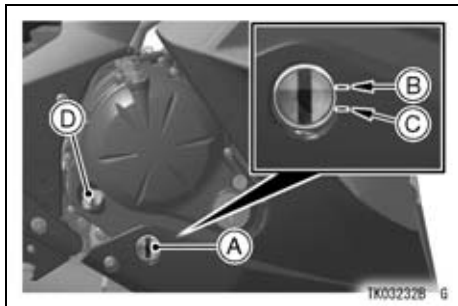

- A. Oil Level Inspection Window
- B. Upper Level Line
- C. Lower Level Line
- D. Oil Filler Cap

- If the oil level is too high, remove the excess oil through the oil filler opening using a syringe or some other suitable device.

- If the oil level is too low, add the oil to reach the correct level. Use the same type and brand of oil that is already in the engine.

### ***NOTICE***

**If the engine oil gets extremely low or if the oil pump does not function properly or oil passages are clogged, the warning indicator light (  ) will go on. If this warning indicator light stays on when the engine speed is slightly above the idle speed, stop the engine immediately and find the cause.**

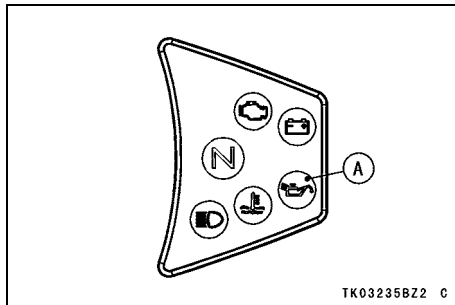

A. Red Oil Pressure Warning Indicator Light

### *Oil and/or Oil Filter Change*

- Warm up the engine thoroughly, and then stop it.
- Place an oil pan beneath the engine.
- Remove the engine oil drain plug.

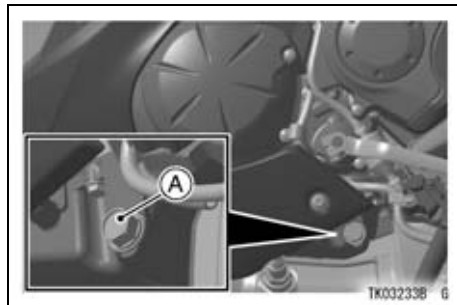

A. Drain Plug

- Let the oil completely drain with the motorcycle perpendicular to the ground.

## **⚠ WARNING**

**Engine oil is a toxic substance. Dispose of used oil properly. Contact your local authorities for approved disposal methods or possible recycling.**

## 102 MAINTENANCE AND ADJUSTMENT

- Remove the right side fairing (refer to the “Cooling System” section in this chapter).
- Remove the oil filter cartridge and replace it with a new one.

### NOTE

- *If a torque wrench or required Kawasaki special tool is not available, this item should be serviced by an authorized Kawasaki dealer.*

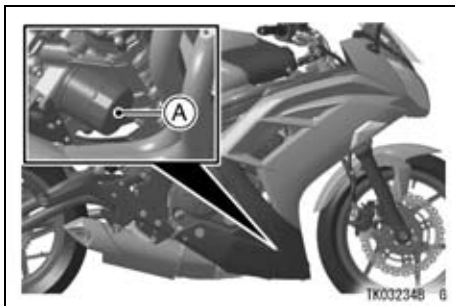

A. Oil Filter Cartridge

- Apply a thin film of oil to the packing and tighten the cartridge to the specified torque.

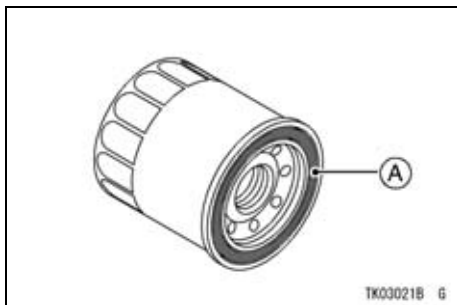

### A. Packing

- Install the drain plug with its new gasket. Tighten it to the specified torque.

### NOTE

- *Replace any gaskets with new ones.*

- Fill the engine up to the upper level line with a good quality engine oil specified in the table.
- Start the engine.
- Check the oil level and oil leakage.

### Tightening Torque

Engine Oil Drain Plug :

30 N·m (3.1 kgf·m, 22 ft·lb)

Oil Filter Cartridge :

17.5 N·m (1.75 kgf·m, 13 ft·lb)

### Recommended Engine Oil

Type:

Kawasaki Performance 4-Stroke  
Motorcycle Oil\*

Kawasaki Performance 4-Stroke  
Semi-Synthetic Oil\*

Kawasaki Performance 4-Stroke Full  
Synthetic Oil\*

or other 4-stroke oils with API SG, SH,  
SJ, SL, SM and JASO MA, MA1, MA2  
rating

Viscosity:

SAE10W-40

\*Kawasaki Performance Oils and Lubricants have been specifically engineered for your vehicle. Consistent use of these products meets or exceeds warranty and service requirements and can help to extend the life of your Kawasaki.



**NOTE**

- Do not add any chemical additive to the oil. Oils fulfilling the above requirements are fully formulated and provide adequate lubrication for both the engine and the clutch.

**Engine Oil Capacity**

Capacity : 1.6 L (1.7 US qt)  
 [when filter is not removed]  
 1.8 L (1.9 US qt)  
 [when filter is removed]  
 2.3 L (2.4 US qt)  
 [when engine is completely dry]

- Install the right side fairing (refer to the "Cooling System" section in this chapter).

Although 10W-40 engine oil is the recommended oil for most conditions, the oil viscosity may need to be changed to accommodate atmospheric conditions in your riding area.

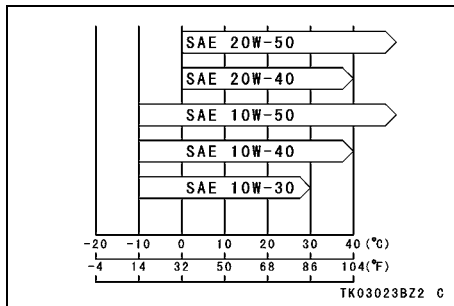

## Cooling System

### Radiator and Cooling Fan -

Check the radiator fins for obstruction by insects or mud. Clean off any obstructions with a stream of low-pressure water.

**WARNING**

The cooling fan spins at high speed and can cause serious injuries. Keep your hands and clothing away from the cooling fan blades at all times.

**NOTICE**

Using high-pressure water, as from a car wash facility, could damage the radiator fins and impair the radiator's effectiveness. Do not obstruct or deflect airflow through the radiator by installing unauthorized accessories in front of the radiator or behind the cooling fan. Interference with the radiator airflow can lead to overheating and consequent engine damage.

### Radiator Hoses -

Check the radiator hoses for leakage, cracks or deterioration, and connections for leakage or looseness each day before riding the motorcycle, and carry out the maintenance and adjustments in accordance with the Periodic Maintenance Chart.

### Coolant -

Coolant absorbs excessive heat from the engine and transfers it to the air at the radiator. If the coolant level becomes low, the engine overheats and may suffer severe damage. Check the coolant level each day before riding the motorcycle, and carry out the maintenance and adjustments in accordance with the periodic maintenance chart. Replenish coolant if the level is low. Change the coolant in accordance with the Periodic Maintenance Chart.

#### *Information for Coolant*

To protect the cooling system (consisting of the aluminum engine and radiator) from rust and corrosion, the use of corrosion and rust inhibitor chemicals in the coolant is essential. If coolant containing corrosion and rust inhibitor chemicals is not used, over a

period of time, the cooling system accumulates rust and scale in the water jacket and radiator. This will clog up the coolant passages, and considerably reduce the efficiency of the cooling system.

### **WARNING**

**Coolant containing corrosion inhibitors for aluminum engines and radiators include harmful chemicals for human body. Drinking coolant can result in serious injury or death. Use coolant in accordance with the instructions of the manufacturer.**

Soft or distilled water must be used with the antifreeze (see below for antifreeze) in the cooling system.

**NOTICE**

**If hard water is used in the system, it causes scale accumulation in the water passages, and considerably reduces the efficiency of the cooling system.**

If the lowest ambient temperature encountered falls below the freezing point of water, use permanent antifreeze in the coolant to protect the cooling system against engine and radiator freeze-up, as well as from rust and corrosion.

Use a permanent type of antifreeze (soft water and ethylene glycol plus corrosion and rust inhibitor chemicals for aluminum engines and radiators) in the cooling system. On the mixture ratio of coolant, choose the suitable one referring to the relation between freezing point and strength directed on the container.

**NOTICE**

**Permanent types of antifreeze on the market have anti-corrosion and anti-rust properties. When it is diluted excessively, it loses its anti-corrosion property. Dilute a permanent type of antifreeze in accordance with the instructions of the manufacturer.**

**NOTE**

- *A permanent type of antifreeze is installed in the cooling system when shipped. It is colored green and contains ethylene glycol. It is mixed at 50% and has the freezing point of  $-35^{\circ}\text{C}$  ( $-31^{\circ}\text{F}$ ).*

*Coolant Level Inspection*

- Situate the motorcycle so that it is perpendicular to the ground.

## 108 MAINTENANCE AND ADJUSTMENT

- Check the coolant level if it is between the F (Full) and L (Low) level lines on the reserve tank located right side of the radiator.

### NOTE

- *Check the level when the engine is cold (room or atmospheric temperature).*

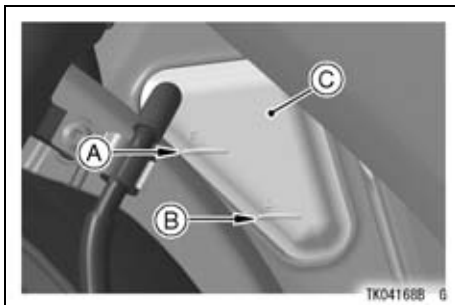

- A. F (Full) Level Line
- B. L (Low) Level Line
- C. Coolant Reserve Tank

- If the amount of coolant is insufficient, remove the right side fairing and add coolant into the reserve tank.

### *Coolant Filling*

- Remove three large quick rivets on the bottom of the fairing. The large quick rivets can be removed by pulling the center pin with a screw driver.
- Remove three small quick rivets behind the right side fairing. The small quick rivets can be removed by pushing the center pin into the rivet.

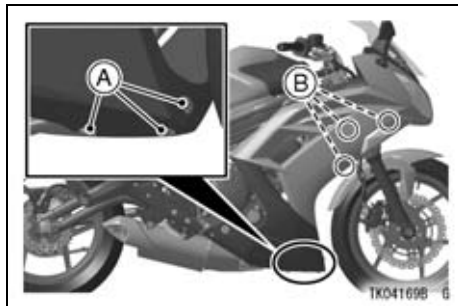

- A. Large Quick Rivets
- B. Small Quick Rivets

### NOTE

- When installing the large quick rivet, insert them into the holes on the fairing and push the center pin to secure them.

- When installing the small quick rivets, pull the center pin fully up first, and push the center pin after inserting them.

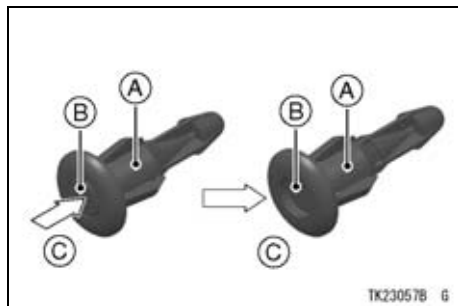

- A. Quick Rivet
- B. Center Pin
- C. Push in.

## 110 MAINTENANCE AND ADJUSTMENT

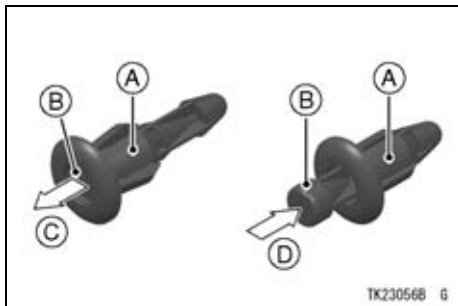

- A. Quick Rivet
- B. Center Pin
- C. Pull up fully.
- D. Push in.

- Remove the right side fairing mounting bolts, nylon washers and collars.

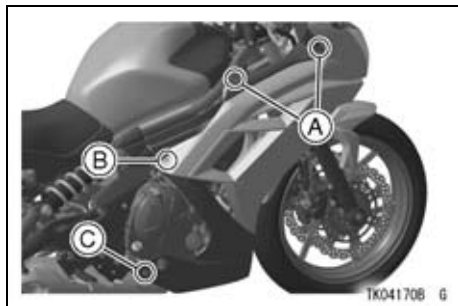

- A. Bolts (Black) and Nylon Washers
- B. Bolt and Collar
- C. Bolt, Nylon Washer and Collar

- Slide the upper edge of the right side fairing rearward carefully to detach all tabs from the holes on the fairings.
- Disconnect the right turn signal light connector and remove the right side fairing.

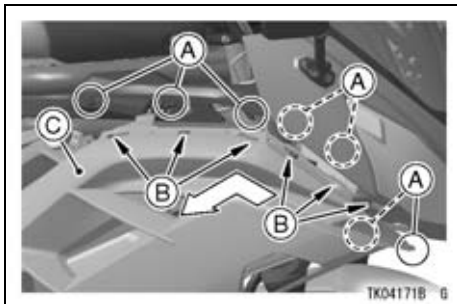

- A. Tabs
- B. Holes
- C. Right Side Fairing

- Remove the cap from the reserve tank and add coolant through the filler opening to the F (Full) level line.

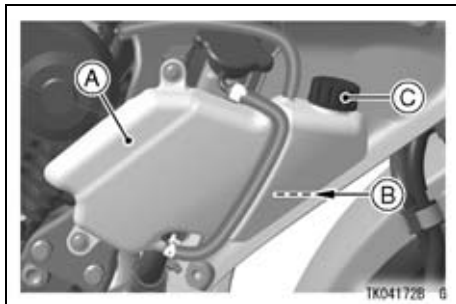

- A. Reserve Tank
- B. F (Full) Level Line
- C. Cap

- Position the right side fairing aligning the tabs with the holes carefully.
- Install the three small quick rivets behind the right side fairing and three large quick rivets at the bottom of the fairing.
- Install the mounting bolts, nylon washers and collars to secure right side fairing.



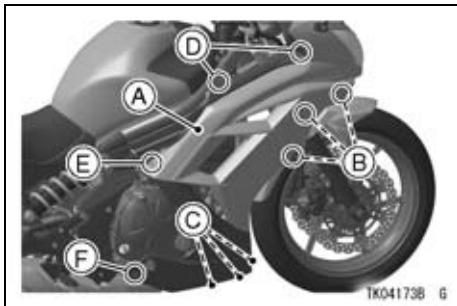

- A. Right Side Fairing
- B. Small Quick Rivets
- C. Large Quick Rivets
- D. Bolts (Black) and Nylon Washers
- E. Bolt and Collar
- F. Bolt, Nylon Washer and Collar

### NOTE

○ *In an emergency you can add water alone to the coolant reserve tank,*

*however it must be returned to the correct mixture ratio by the addition of antifreeze concentrate as soon as possible.*

### NOTICE

**If coolant must be added often, or the reserve tank completely runs dry, there is probably leakage in the system. Have the cooling system inspected by your authorized Kawasaki dealer.**

### *Coolant Change*

Have the coolant changed by an authorized Kawasaki dealer.

## Spark Plugs

The standard spark plug is shown in the table. The spark plugs should be replaced in accordance with the Periodic Maintenance Chart.

Spark plug removal should be done by a competent mechanic following the procedures in the Service Manual.

### Spark Plug

Standard Plug	NGK CR9EIA-9
Plug Gap	0.8 ~ 0.9 mm (0.031 ~ 0.035 in.)
Tightening Torque	15 N·m (1.5 kgf·m, 11 ft·lb)

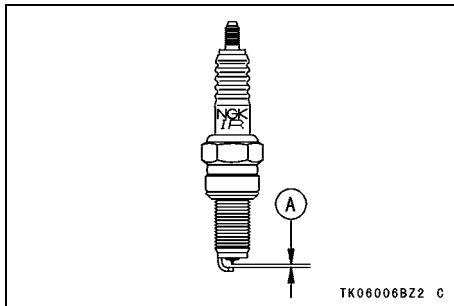

A. Plug Gap

## Evaporative Emission Control System (California model only)

This system routes fuel vapors from the fuel system into the running engine or stores the vapors in a canister when the engine is stopped. Although no adjustments are required, a thorough visual inspection must be made at the intervals specified by the Periodic Maintenance Chart.

### Inspection

- Check that the hoses are securely connected.
- Replace any kinked, deteriorated, or damaged hoses.

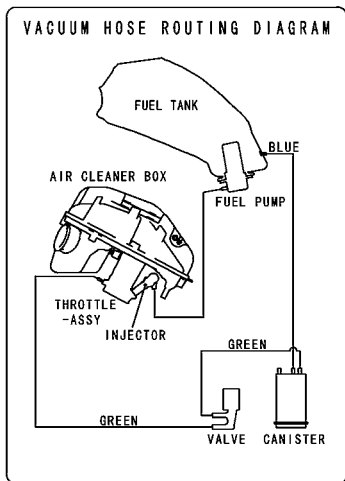

59465-0562

## **Kawasaki Clean Air System**

The Kawasaki Clean Air System (KCA) is a secondary air suction system that helps the exhaust gases to burn more completely. When the spent fuel charge is released into the exhaust system, it is still hot enough to burn. The KCA System allows extra air into the exhaust system so that the spent fuel charge can continue to burn. This continued burning action tends to burn up a great deal of the normally unburned gases, as well as changing a significant portion of the carbon monoxide into carbon dioxide.

### **Air Suction Valves -**

The air suction valve is essentially a check valve which allows fresh air to flow only from the air cleaner into the exhaust port. Any air that has passed

the air suction valve is prevented from returning. Inspect the air suction valves in accordance with the Periodic Maintenance Chart. Also, inspect the air suction valves whenever stable idling cannot be obtained, engine power is greatly reduced, or there are abnormal engine noises.

Air suction valve removal and inspection should be done by a competent mechanic following the procedures in the Service Manual.

## Valve Clearance

Valve and valve seat wear decreases valve clearance, upsetting valve timing.

<b><i>NOTICE</i></b>
----------------------

<p><b>If valve clearance is left unadjusted, wear will eventually cause the valves to remain partly open, which lowers performance, burns the valves and valve seats, and may cause serious engine damage.</b></p>
--

Valve clearance for each valve should be checked and adjusted in accordance with the Periodic Maintenance Chart.

Inspection and adjustment should be done by a competent mechanic following the procedures in the Service Manual.

## Air Cleaner

A clogged air cleaner restricts the engine's air intake, increasing fuel consumption, reducing engine power, and causing spark plug fouling.

The air cleaner element must be replaced in accordance with the Periodic Maintenance Chart. This motorcycle's air cleaner element consists of a wet paper filter, which cannot be cleaned. In dusty, rainy, or on muddy conditions, the air cleaner element should be serviced more frequently than the recommended interval.

### **NOTICE**

**Use only the recommended air cleaner element (Kawasaki part number 11013-0713). Using the any other air cleaner element will wear the engine prematurely or lower the engine performance.**

## Oil Draining

- Inspect the drain hose located on the left side of the engine to see if any oil or water has run down from the air cleaner housing.

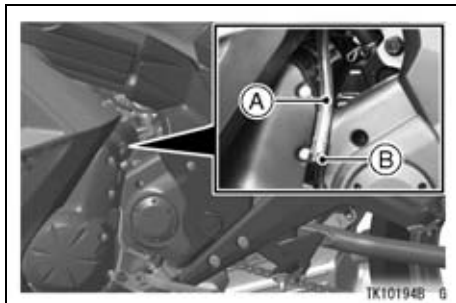

- A. Drain Hose
- B. Plug

- If there is any oil in the hose, remove the plug and drain the oil.

 **WARNING**

**Oil on tires will make them slippery and can cause an accident and injury. Be sure to install the plug in the drain hose after draining.**

## **Throttle Control System**

Check the throttle grip play in accordance with the Periodic Maintenance Chart, and adjust it if necessary.

### **Throttle Grip -**

The throttle grip controls the butterfly valves in the throttle body. If the throttle grip has excessive play due to either cable stretch or maladjustment, it will cause a delay in throttle response, especially at low engine speed. Also, the throttle valve may not open fully at full throttle. On the other hand, if the throttle grip has not play, the throttle will be hard to control, and the idle speed will be erratic.

#### *Inspection*

- Check that the throttle grip play is correct by lightly turning the throttle grip back and forth.

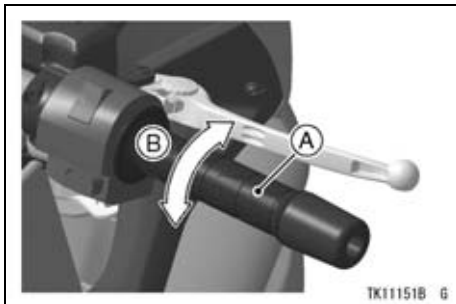

- A. Throttle Grip
- B. Throttle Grip Play

### Throttle Grip Play

2 ~ 3 mm (0.08 ~ 0.12 in.)

- If there is improper play, adjust it.

### Adjustment

- Loosen the locknut at the throttle grip, and turn the adjuster until the proper amount of throttle grip play is obtained.

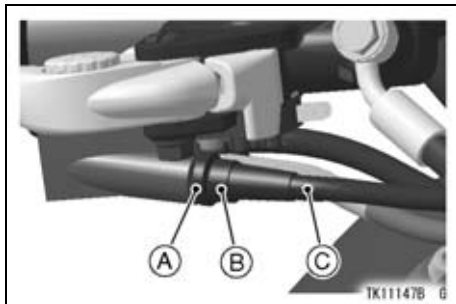

- A. Locknut
- B. Adjuster
- C. Throttle Cable (Accelerator Cable)

- If the throttle grip play cannot be adjusted with the accelerator cable adjuster at the throttle grip, use the decelerator cable adjuster located under the fuel tank.
- Remove the right side fairing (refer to the “Cooling System” section in this chapter).



## 120 MAINTENANCE AND ADJUSTMENT

- Turn out the decelerator cable adjusting nut until there is no play when the throttle grip is completely closed.
- Tighten the locknut.

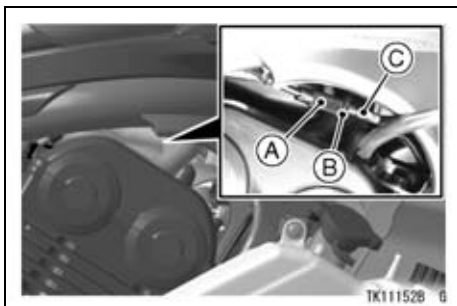

- A. Adjuster
- B. Locknut
- C. Throttle Cable (Decelerator Cable)

- Turn the accelerator cable adjusting nut until a play of 2 ~ 3 mm (0.08 ~ 0.12 in.) is obtained at the throttle grip.

- Tighten the locknut.
- With the engine idling, turn the handlebar to each side. If handlebar movement changes the idle speed, the throttle cables may be improperly adjusted or incorrectly routed, or they may be damaged. Be sure to correct any of these conditions before idling.

### **⚠ WARNING**

**Operation with improperly adjusted, incorrectly routed, or damaged cables could result in an unsafe riding condition. Be sure the control cables are adjusted and routed correctly, and are free from damage.**

- Install the right side fairing (refer to the “Cooling System” section in this chapter).

## Engine Vacuum Synchronization

Engine vacuum synchronization must be checked and adjusted periodically in accordance with the Periodic Maintenance Chart by a competent mechanic following the procedures in the Service Manual.

### NOTE

- *Poor engine vacuum synchronization will cause unstable idling, sluggish throttle response, and reduce engine power and performance.*

## Idle Speed

The idle speed check should be performed in accordance with the Periodic Maintenance Chart or whenever the idle speed is disturbed.

### Adjustment

- Start the engine, and warm it up thoroughly.
- Adjust the idle speed by turning the idle adjusting screw.

### NOTE

- *While the engine is cold, the fast idle system automatically raises the engine idling speed.*

## Idle Speed

1 250 ~ 1 350 r/min (rpm)
---------------------------

## 122 MAINTENANCE AND ADJUSTMENT

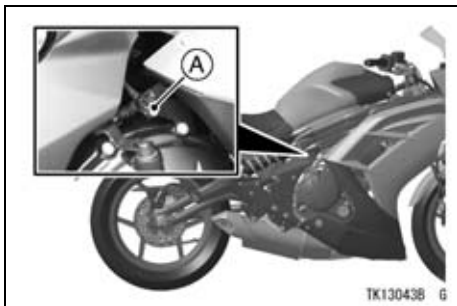

### A. Idle Adjusting Screw

- Open and close the throttle a few times to make sure that the idle speed does not change. Readjust if necessary.
- With the engine idling, turn the handlebar to each side. If handlebar movement changes the idle speed, the throttle cables may be improperly adjusted or incorrectly routed, or they may be damaged. Be sure to correct any of these conditions before riding.

### **⚠ WARNING**

**Operation with damaged cables could result in an unsafe riding condition. Replace damaged control cables before operation.**

## Clutch

Due to friction plate wear and clutch cable stretch over a long period of use, the clutch operation should be checked each day before riding the motorcycle, and carry out the maintenance and adjustments in accordance with the Periodic Maintenance Chart.

### **⚠ WARNING**

**The engine and exhaust system get extremely hot during normal operation and can cause serious burns. Never touch a hot engine or an exhaust pipe during clutch adjustment.**

#### *Inspection*

- Check that the clutch lever operates properly and that the inner cable

slides smoothly. If there is any irregularity, have the clutch cable checked by an authorized Kawasaki dealer.

- Check the clutch lever play as shown in the figure.

#### Clutch Lever Play

2 ~ 3 mm (0.08 ~ 0.12 in.)

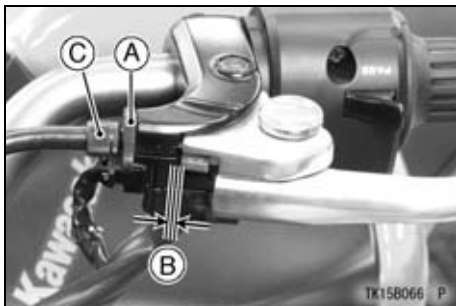

- A. Locknut
- B. Clutch Lever Play
- C. Adjuster

## 124 MAINTENANCE AND ADJUSTMENT

If the play is incorrect, adjust the lever play as follows.

### *Adjustment*

- Loosen the locknut, and turn the adjuster so that the clutch lever will have the proper play.

### **WARNING**

Too much cable play can prevent clutch disengagement and cause an accident resulting in serious injury or death. When adjusting the clutch or replacing the cable, be sure the upper end of the clutch outer cable is fully seated in its fitting, or it could slip into place later, creating enough cable play to prevent clutch disengagement.

- If it cannot be done, have the clutch cable adjusted by an authorized Kawasaki dealer.

### **NOTE**

- *After the adjustment is made, start the engine and check that the clutch does not slip and releases properly.*

## Drive Chain

The drive chain slack and lubrication must be checked each day before riding the motorcycle, and must be maintained in accordance with the Periodic Maintenance Chart for safety and to prevent excessive wear. If the chain becomes badly worn or maladjusted - either too loose or too tight - the chain could jump off the sprockets or break.

### WARNING

**A chain that breaks or jumps off the sprockets could snag on the engine sprocket or lock the rear wheel, severely damaging the motorcycle and causing it to go out of control. Inspect the chain for damage and proper adjustment before each ride.**

### *Chain Slack Inspection*

- Set the motorcycle up on its side stand.
- Rotate the rear wheel to find the position where the chain is tightest, and measure the maximum chain slack by pulling up and pushing down the chain midway between the engine sprocket and rear wheel sprocket.

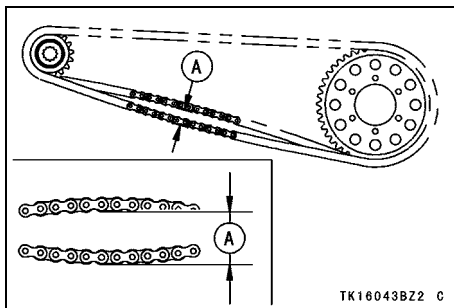

A. Chain Slack

TK16043BZ2 C

## 126 MAINTENANCE AND ADJUSTMENT

- If the drive chain is too tight or too loose, adjust it so that the chain slack will be within the standard value.

### Drive Chain Slack

Standard	25 ~ 35 mm (1.0 ~ 1.4 in.)
----------	----------------------------

### *Chain Slack Adjustment*

- Loosen the left and right chain adjuster locknuts.
- Remove the cotter pin, and loosen the axle nut.

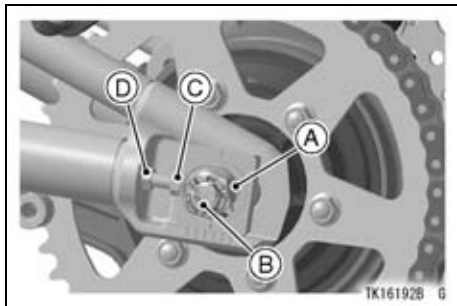

- A. Axle Nut**
- B. Cotter Pin**
- C. Adjuster**
- D. Locknut**

- If the chain is too loose, turn out the left and right chain adjusters evenly.
- If the chain is too tight, turn in the left and right chain adjusters evenly.
- Turn out both chain adjusters evenly until the drive chain has the correct amount of slack. To keep the chain and wheel properly aligned, the notch on the left wheel alignment

indicator should align with the same swingarm mark that the right indicator notch aligns with.

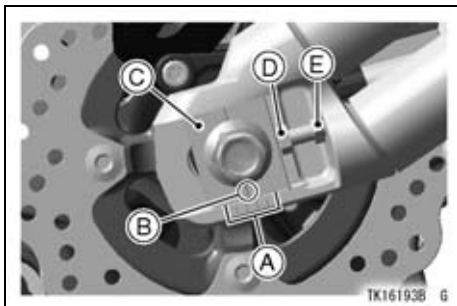

- A. Marks
- B. Notch
- C. Indicator
- D. Adjuster
- E. Locknut

## NOTE

- *Wheel alignment can also be checked using the straightedge or string method.*

## **⚠** WARNING

Misalignment of the wheel will result in abnormal wear, and may result in an unsafe riding condition. Align the rear wheel using the marks on the swingarm or measuring the distance between the center of the axle and swingarm pivot.

- Tighten both chain adjuster locknuts.
- Tighten the rear axle nut to the specified torque.

### Tightening Torque

Axle Nut:

108 N·m (11 kgf·m, 80 ft·lb)



**NOTE**

- If a torque wrench is not available, this item should be serviced by an authorized Kawasaki dealer.
- Rotate the wheel, measure the chain slack again at the tightest position, and readjust if necessary.
- Install a new cotter pin through the rear axle nut and axle, and spread its ends.

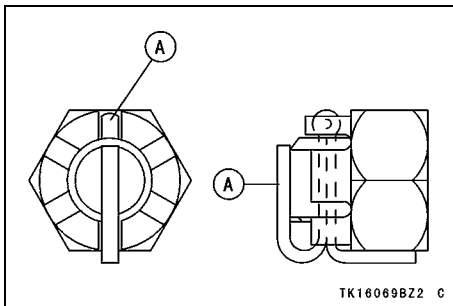
**A. Cotter Pin****NOTE**

- When inserting the cotter pin, if the slots in the nut do not align with the cotter pin hole in the axle shaft, tighten the nut clockwise up to the next alignment.
- It should be within 30 degrees.
- Loosen once and tighten again when the slot goes past the nearest hole.

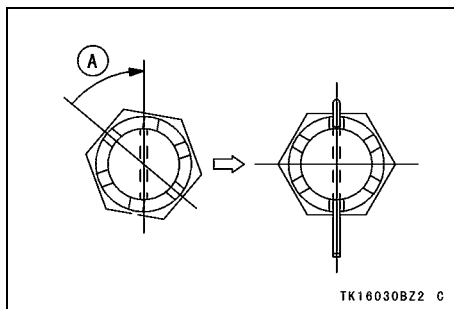
**A. Turning Clockwise**

## **⚠ WARNING**

A loose axle nut can lead to an accident resulting in serious injury or death. Tighten the axle nut to the proper torque and install a new cotter pin.

- Check the rear brake (see the Brakes section).

### *Wear Inspection*

- Remove the bolts and chain cover.

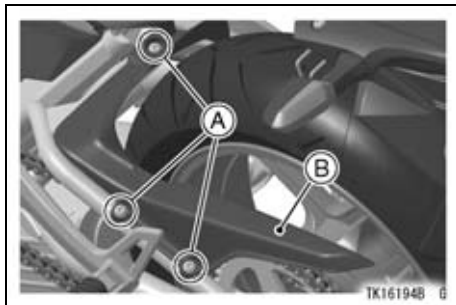

**A. Bolts**

**B. Chain Cover**

- Stretch the chain taut either by using the chain adjusters, or by hanging a 10 kg (22 lb) weight on the chain.
- Measure the length of 20 links on the straight part of the chain from pin center of the 1st pin to pin center of the 21st pin. Since the chain may wear unevenly, take measurements at several places.

## 130 MAINTENANCE AND ADJUSTMENT

- If the length exceeds the service limit, the chain should be replaced.

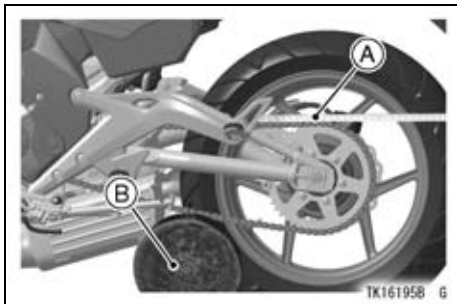

- A. Measure
- B. Weight

### *Drive Chain 20-Link Length*

Service Limit: 323 mm (12.7 in.)

## **⚠ WARNING**

**For safety, use only the standard chain. It is an endless type and should not be cut for installation; have it installed by an authorized Kawasaki dealer.**

- Install the chain cover and bolts.
- Rotate the rear wheel to inspect the drive chain for damaged rollers, and loose pins and links.
- Also inspect the sprockets for unevenly or excessively worn teeth, and damaged teeth.

## **NOTE**

- *Sprocket wear is exaggerated for illustration. See Service Manual for wear limits.*

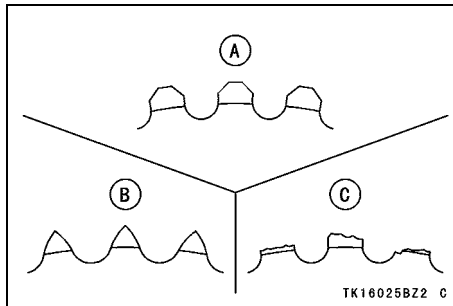

- A. Good Teeth
- B. Worn Teeth
- C. Damaged Teeth

- If there is any irregularity, have the drive chain and/or the sprockets replaced by an authorized Kawasaki dealer.

### Lubrication

Lubrication is necessary after riding through rain or on wet roads, or any time that the chain appears dry.

Use a lubricant for sealed chains to prevent deterioration of chain seals. If the chain is especially dirty, clean it using a cleaner for sealed chains following the instructions supplied by the chain cleaner manufacturer.

- Apply lubricant to the sides of the rollers so that it will penetrate to the rollers and bushings. Apply lubricant to the seals so that the seals will be coated with lubricant. Wipe off any excess lubricant.

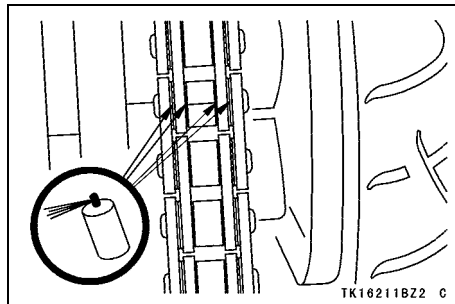

## 132 MAINTENANCE AND ADJUSTMENT

- Wipe off any lubricant that gets on the tire surface.

### Brakes

#### *Brake Wear Inspection*

Inspect the brakes for wear. For each front and rear disc brake caliper, if the thickness of either pad is less than 1 mm (0.04 in.), replace both pads in the caliper as a set. Pad replacement should be done by an authorized Kawasaki dealer.

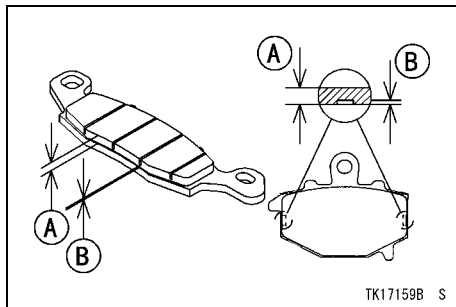

**A. Lining Thickness**

**B. 1 mm (0.04 in.)**

## Brake Fluid -

In accordance with the Periodic Maintenance Chart, inspect the brake fluid level in both the front and rear brake fluid reservoirs and change the brake fluid. The brake fluid should also be changed if it becomes contaminated with dirt or water.

### *Fluid Requirement*

Use heavy-duty brake fluid only from a container marked DOT4.

## **NOTICE**

**Do not spill brake fluid onto any painted surface.**

**Do not use fluid from a container that has been left open or that has been unsealed for a long time.**

**Check for fluid leakage around the fittings.**

**Check brake hose for damage.**

### *Fluid Level Inspection*

- The brake fluid level in the front brake fluid reservoir must be kept above the line (lower level line) next to the gauge and that in the rear brake fluid reservoir (located under the rider's seat) must be kept between the upper and lower level lines (reservoirs held horizontal).

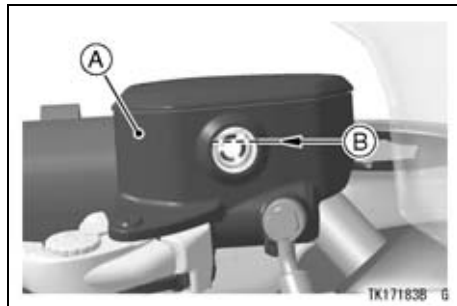

**A. Front Brake Fluid Reservoir**

**B. Lower Level Line**

## 134 MAINTENANCE AND ADJUSTMENT

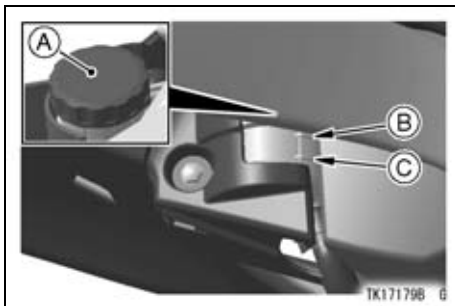

- A. Rear Brake Fluid Reservoir**
- B. Upper Level Line**
- C. Lower Level Line**

- If the fluid level in either reservoir is lower than the lower level line, check for fluid leaks in the brake lines, and fill the reservoir to the upper level

line. Inside the front brake fluid reservoir is a stepped line showing the upper level line.

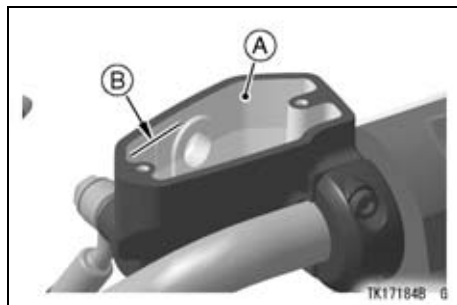

- A. Front Brake Fluid Reservoir**
- B. Upper Level Line**

## **⚠ WARNING**

Mixing brands and types of brake fluid can reduce the brake system's effectiveness and cause an accident resulting in injury or death. Do not mix two brands of brake fluid. Change the brake fluid in the brake line completely if the brake fluid must be refilled but the type and brand of the brake fluid that is already in the reservoir are unidentified.

## **NOTE**

- *First, tighten until slight resistance is felt, which indicates that the cap is seated on the reservoir body; then, tighten the cap an additional 1/6 turn while holding the brake fluid reservoir body.*



- A. Reservoir
- B. Cap
- C. Clockwise
- D. 1/6 turn

## *Fluid Change*

Have the brake fluid changed by an authorized Kawasaki dealer.

## **Front and Rear Brakes -**

Disc and disc pad wear is automatically compensated for and has no effect on the brake lever or pedal action.



So there are no parts that require adjustment on the front brakes and rear brakes.

### **WARNING**

**Air in the brake lines diminish braking performance and can cause an accident resulting in injury or death. If the brake lever or pedal feels mushy when it is applied, there might be air in the brake lines or the brake may be defective. Have the brake checked immediately by an authorized Kawasaki dealer.**

## **Brake Light Switches**

When either the front or rear brake is applied, the brake light goes on. The front brake light switch requires no adjustment, but the rear brake light switch should be adjusted in accordance with the Periodic Maintenance Chart.

### *Inspection*

- Turn the ignition key to “ON”.
- The brake light should go on when the front brake is applied.
- If it does not, ask your authorized Kawasaki dealer to inspect the front brake light switch.
- Check the operation of the rear brake light switch by depressing the brake pedal. The brake light should go on after the proper pedal travel.

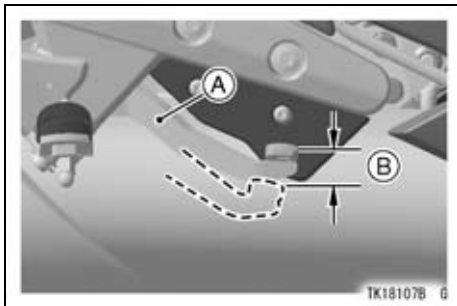

- A. Brake Pedal
- B. Pedal Travel

- If it does not, adjust the rear brake light switch.

**Brake Pedal Travel**

**10 mm (0.4 in.)**

*Adjustment*

- To adjust the rear brake light switch, remove bolt and the right frame side cover.

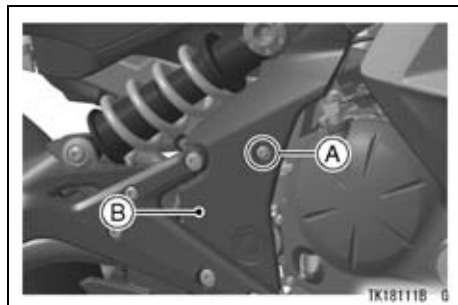

- A. Bolt
- B. Right Frame Side Cover

- Move the switch up or down by turning the adjusting nut.

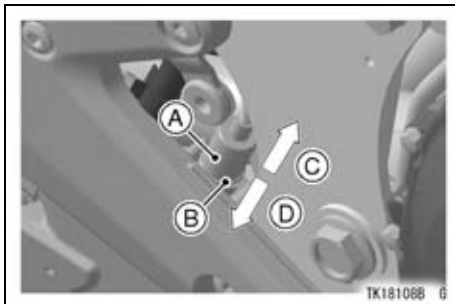

A. Rear Brake Light Switch

B. Adjusting Nut

C. Lights sooner

D. Lights later

- Reinstall the right frame side cover and bolt.

## ***NOTICE***

To avoid damaging the electrical connections inside the switch, be sure that the switch body does not turn during adjustment.

## Front Fork

The front fork operation and oil leakage should be checked in accordance with the Periodic Maintenance Chart.

### *Front Fork Inspection*

- Holding the brake lever, pump the front fork up and down several times to inspect smooth stroke.
- Visually inspect the front fork for oil leakage, scoring or scratches on the outer surface of the inner tube.
- If any doubt about the front fork, it should be checked by an authorized Kawasaki dealer.

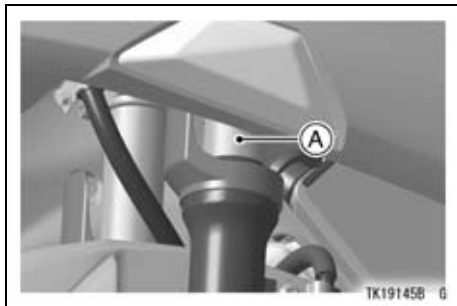

**A. Inner Tube**

### Rear Shock Absorber

The rear shock absorber should be checked operation and oil leakage in accordance with the Periodic Maintenance Chart.

#### *Rear Shock Absorber Inspection*

- Press down on the seat several times to check if the rear shock absorber stroke is smooth.
- Visually inspect the rear shock absorber for oil leaks.
- If there is any doubt about the rear shock absorber, it should be inspected by an authorized Kawasaki dealer.



**A. Rear Shock Absorber**

The rear shock absorber can be adjusted by changing the spring preload for various riding and loading conditions.

### Spring Preload Adjustment

The spring preload adjuster on the rear shock absorber has 7 positions.

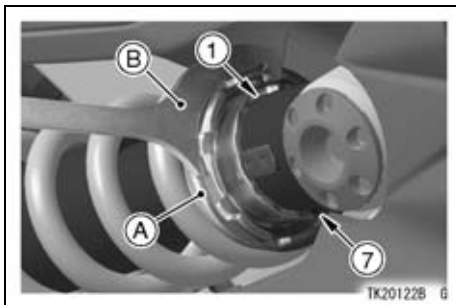

A. Spring Preload Adjuster

B. Wrench

- In accordance with the following table, turn the preload adjuster with the wrench from the tool kit.

## 142 MAINTENANCE AND ADJUSTMENT

### Spring Preload Setting

Adjuster Position	1	2	3	4	5	6	7
Spring Action	Weak		← <b>Standard</b> →	Strong			
Setting	Soft		← <b>Standard</b> →	Hard			
Load	Light		← <b>Standard</b> →	Heavy			
Road	Good		← <b>Standard</b> →	Bad			
Speed	Low		← <b>Standard</b> →	High			

## Wheels

Tubeless tires are installed on the wheels of this motorcycle. The indications of TUBELESS on the tire side wall and the rim show that the tire and rim are specially designed for tubeless use.



**A. TUBELESS Mark**

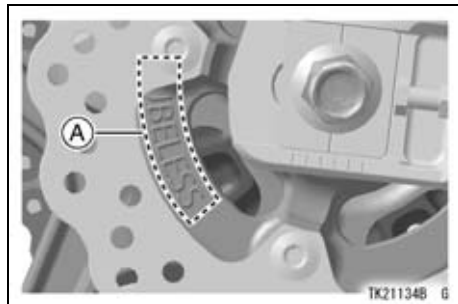

**A. TUBELESS Mark**

The tire and rim form a leakproof unit by making airtight contacts at the tire chamfers and the rim flanges instead of using an inner tube.



 **WARNING**

Installing a tube inside a tubeless-type tire can create excessive heat build up that can damage the tube and cause rapid deflation. The tires, rims, and air valves on this motorcycle are designed only for tubeless type wheels. The recommended standard tires, rims, and air valves must be used for replacement. Do not install tube-type tires on tubeless rims. The beads may not seat properly on the rim causing tire deflation. Do not install a tube inside a tubeless tire. Excessive heat build-up may damage the tube causing tire deflation.

**Tires -***Payload and Tire Pressure*

Failure to maintain proper inflation pressures or observe payload limits for your tires may adversely affect handling and performance of your motorcycle and can result in loss of control. The maximum recommended load in addition to vehicle weight is 200 kg (441 lb), including rider, passenger, baggage, and accessories.

- Remove the air valve cap.
- Check the tire pressure often, using an accurate gauge.
- Make sure to install the air valve cap securely.

**NOTE**

- *Measure the tire pressure when the tires are cold (that is, when the motorcycle has not been ridden more than a mile during the past 3 hours).*

- *Tire pressure is affected by changes in ambient temperature and altitude, and so the tire pressure should be checked and adjusted when your riding involves wide variations in temperature or altitude.*

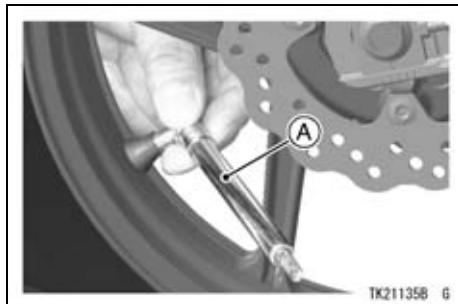

**A. Tire Pressure Gauge**

#### **Tire Air Pressure (when cold)**

Front	225 kPa (2.25 kgf/cm <sup>2</sup> , 32 psi)
Rear	250 kPa (2.50 kgf/cm <sup>2</sup> , 36 psi)

#### **Tire Wear, Damage**

As the tire tread wears down, the tire becomes more susceptible to puncture and failure. An accepted estimate is that 90% of all tire failures occur during the last 10% of tread life (90% worn). So it is false economy and unsafe to use the tires until they are bald.

- In accordance with the Periodic Maintenance Chart, measure the depth of the tread with a depth gauge, and replace any tire that has worn down to the minimum allowable tread depth.

#### **Minimum Tread Depth**

Front	—————	1 mm (0.04 in.)
Rear	Up to 130 km/h (80 mph)	2 mm (0.08 in.)
	Over 130 km/h (80 mph)	3 mm (0.12 in.)

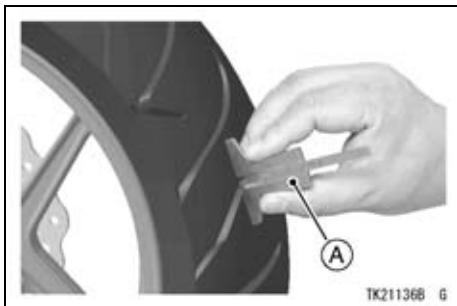

#### A. Tire Depth Gauge

- Visually inspect the tire for cracks and cuts, replacing the tire in case of bad damage. Swelling or high spots indicate internal damage, requiring tire replacement.
- Remove any imbedded stones or other foreign particles from the tread.

#### NOTE

- *Have the wheel balance inspected whenever a new tire is installed.*

## **⚠ WARNING**

Tires that have been punctured and repaired do not have the same capabilities as undamaged tires and can suddenly fail, causing an accident resulting in serious injury or death. Replace damaged tires as soon as possible. To ensure safe handling and stability, use only the recommended standard tires for replacement, inflated to the standard pressure. If it is necessary to ride on a repaired tire, do not exceed 100 km/h (60 mph) until the tire is replaced.

#### NOTE

- *When operating on public roadways, keep maximum speed under traffic law limits.*

**Standard Tire (Tubeless)**

Front	Size: 120/70ZR17 M/C (58W) DUNLOP ROADSMART II J
Rear	Size: 160/60ZR17 M/C (69W) DUNLOP ROADSMART II J

 **WARNING**

Mixing tire brands and types can adversely affect handling and cause an accident resulting in injury or death. Always use the same manufacturer's tires on both front and rear wheels.

 **WARNING**

New tires are slippery and may cause loss of control and injury. A break-in period of 160 km (100 miles) is necessary to establish normal tire traction. During break-in, avoid sudden and maximum braking and acceleration, and hard cornering.

### Battery

The battery installed in this motorcycle is a sealed type, so it is not necessary to check the battery electrolyte level or add distilled water.

The sealing strip should not be pulled off once the specified electrolyte has been installed in the battery for initial service.

However, in order to maximize battery life and ensure that it will provide the power needed to start the motorcycle you must properly maintain the battery's charge. When used regularly, the charging system in the motorcycle helps keep the battery fully charged. If your motorcycle is only used occasionally or for short periods of time, the battery is more likely to discharge.

Due to their internal composition, batteries continually self discharge. The discharge rate depends on the type of battery and ambient temperature. As temperature rises, so does the discharge rate. Every 15°C (59°F) doubles the rate.

Electrical accessories, such as digital clocks and computer memory, also draw current from the battery even when the key is switched off. Due to a combination of such "key-off" draws and hot temperature, a battery can go from fully charged to completely discharged in a matter of days.

Self-discharge		
Temperature	Approx. Number of Days From 100% Charged to 100% discharged	
	Lead -Antimony	Lead -Calcium
	Battery	Battery
40°C (104°F)	100 Days	300 Days
25°C (77°F)	200 Days	600 Days
0°C (32°F)	550 Days	950 Days

Current Drain		
Discharging Ampere	Days from 100% charged to 50% Discharged	Days from 100% charged to 100% Discharged
7 mA	60 Days	119 Days
10 mA	42 Days	83 Days
15 mA	28 Days	56 Days
20 mA	21 Days	42 Days
30 mA	14 Days	28 Days

In extremely cold weather the fluid in an inadequately charged battery can easily freeze, which can crack the case and buckle the plates. A fully charged battery can withstand sub-freezing temperature with no damage.

### Battery Sulfation

A common cause of battery failure is sulfation.

## 150 MAINTENANCE AND ADJUSTMENT

Sulfation occurs when the battery is left in a discharged condition for an extended time. Sulfate is a normal by product of the chemical reactions within a battery. But when continuous discharge allows the sulfate to crystallize in the cells, the battery plates become permanently damaged and will not hold a charge. Battery failure due to sulfation is not warrantable.

### **Battery Maintenance**

It is the owner's responsibility to keep the battery fully charged. Failure to do so can lead to battery failure and leave you stranded.

If you are riding your vehicle infrequently, inspect the battery voltage weekly using a voltmeter. If it drops below 12.8 volts, the battery should be charged using an appropriate charger (check with an authorized Kawasaki dealer). If you will not be using the

motorcycle for longer than two weeks, the battery should be charged using an appropriate charger. Do not use an automotive-type quick charger that may overcharge the battery and damage it.

### **NOTE**

○ *Leaving the battery connected causes the electrical components (clock etc) to make the battery discharged, resulting the over discharge of the battery. In this case, the repair or replacement of the battery is not included in the warranty. If you do not drive for four weeks or more, disconnect the battery from the vehicle.*

### **Kawasaki-recommended chargers are:**

Battery Mate 150-9

OptiMate 4

Yuasa MB-2040/2060

Christie C10122S

If the above chargers are not available, use equivalent one.

For more details, ask your Kawasaki dealer.

### Battery Charging

- Remove the battery from the motorcycle (see Battery Removal).
- Attach the leads from the charger and charge the battery at a rate (amperage × hours) that is indicated on the battery. If it is not possible to read the rate, charge the battery at an amperage that is about 1/10th of the battery capacity.
- The charger will keep the battery fully charged until you are ready to re-install the battery in the motorcycle (see Battery Installation).

## NOTICE

**Never remove the sealing strip, or the battery can be damaged. Do not install a conventional battery in this motorcycle, or the electrical system cannot work properly.**

Make	Yuasa Battery
Type	YT12A-BS

## NOTE

- *If you charge the sealed battery, never fail to observe the instructions shown in the label on the battery.*



## **⚠ WARNING**

**Battery posts, terminals and related accessories contain lead and lead compounds, chemicals known to the State of California to cause cancer and reproductive harm. Wash hands after handling.**

### *Battery Removal*

- Remove the passenger's seat and rider's seat.
- Disconnect the cables from the battery, first from the (-) terminal and then the (+) terminal.
- Remove the bolts and bracket, then take the battery out of the case.
- Clean the battery using a solution of baking soda and water. Be sure that the cable connections are clean.

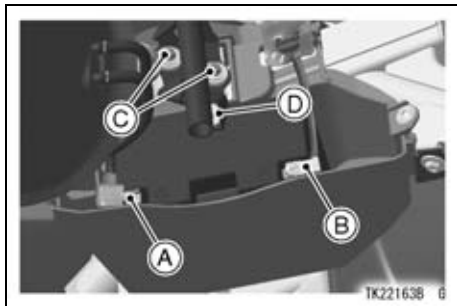

- A. (+) Terminal
- B. (-) Terminal
- C. Bolts
- D. Bracket

### *Battery Installation*

- Place the battery in the battery case.
- Connect the capped cable to the (+) terminal, and then connect the black cable to the (-) terminal.

**NOTE**

- *Install the battery in the reverse order of the Battery Removal.*

**NOTICE**

**Installing the (-) cable to the (+) terminal of the battery or the (+) cable to the (-) terminal of the battery can seriously damage the electrical system.**

- Put a light coat of grease on the terminals to prevent corrosion.
- Cover the (+) terminal with its protective cap.
- Reinstall the removed parts.

**Headlight Beam***Horizontal Adjustment*

The headlight beam is adjustable horizontally. If not properly adjusted horizontally, the beam will point to one side rather than straight ahead.

- Turn the horizontal adjuster clockwise or counterclockwise until the beam points straight ahead.

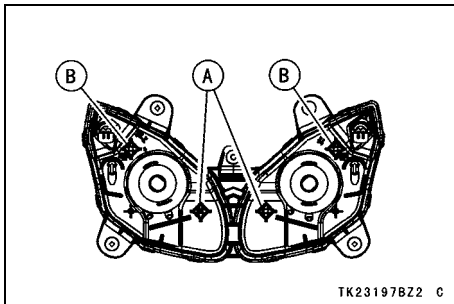

- A. Horizontal Adjuster**
- B. Vertical Adjuster**

TK23197B22 C



## Fuses

Fuses are arranged in the fuse boxes located under the fuel tank cover and the left frame cover for ABS model. The main fuse is mounted on the starter relay under the rider's seat. If a fuse fails during operation, inspect the electrical system to determine the cause, and then replace it with a new fuse of proper amperage.

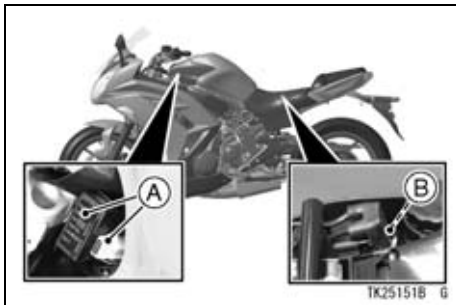

A. Fuse Boxes  
B. Main Fuse

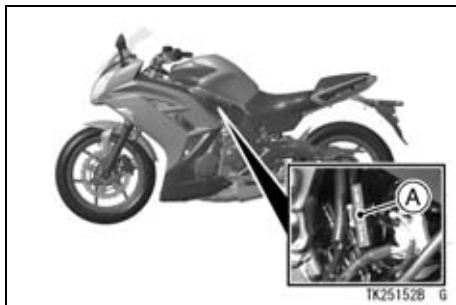

A. Fuse Box (for models equipped with ABS)

## **⚠** WARNING

Substituting fuses can cause wiring to overheat, catch fire and/or fail. Do not use any substitute for the standard fuse. Replace the blown fuse with a new one of the correct capacity, as specified on the junction box and main fuse.

## 156 MAINTENANCE AND ADJUSTMENT

- To access the fuse boxes, remove the bolts and slide each side of the tank front cover forwards then pull up the front of the cover to remove it.

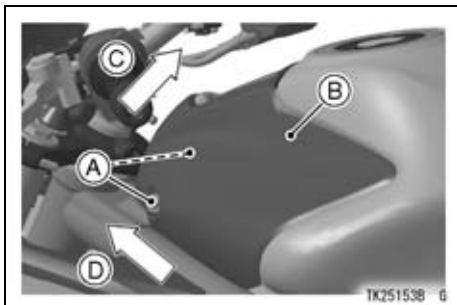

- A. Bolts
- B. Tank Front Cover
- C. Pull Up Cover
- D. Slide Cover Forward

- To access the fuse box for ABS, remove the left frame side cover by removing the bolt.

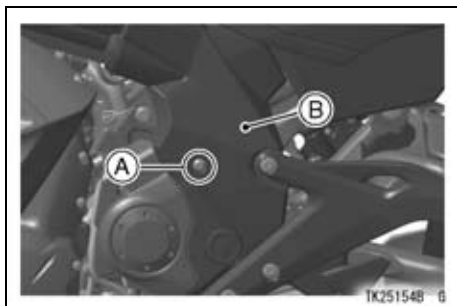

- A. Bolt
- B. Left Frame Side Cover

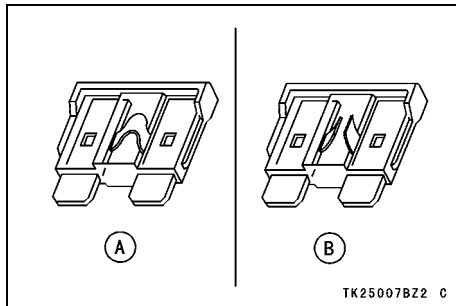

- A. Normal  
B. Failed

## General Lubrication

Lubricate the points shown below, with either motor oil or regular grease, in accordance with the Periodic Maintenance Chart or whenever the vehicle has been operated under wet or rainy conditions.

Before lubricating each part, clean off any rusty spots with rust remover and wipe off any grease, oil, dirt, or grime.

### NOTE

- *A few drops of oil are effective to keep bolts and nuts from rusting and sticking. This makes removal easier. Badly rusted nuts, bolts, etc., should be replaced with new ones.*

## 158 MAINTENANCE AND ADJUSTMENT

### Apply engine oil to the following pivots -

- Side Stand
- Clutch Lever
- Front Brake Lever
- Rear Brake Pedal

### Lubricate the following cables with a pressure cable luber -

- (K) Clutch Inner Cable
- (K) Throttle Inner Cables

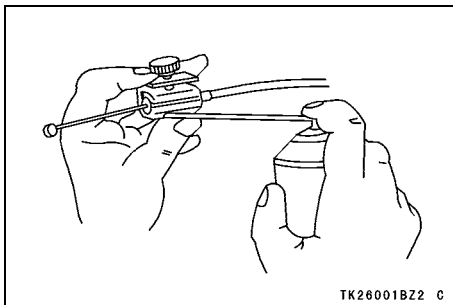

### Apply grease to the following points -

- (K) Clutch Inner Cable Upper End
- (K) Throttle Inner Cable Upper Ends

(K): Should be serviced by an authorized Kawasaki dealer.

### NOTE

- *After connecting the cables, adjust them.*

## Cleaning Your Motorcycle

### *General Precautions*

Frequent and proper care of your Kawasaki motorcycle will enhance its appearance, optimize overall performance, and extend its useful life. Covering your motorcycle with a high quality, breathable motorcycle cover will help protect its finish from harmful UV rays, pollutants, and reduce the amount of dust reaching its surfaces.

### **WARNING**

**Build-up of debris or flammable material in and around the vehicle chassis, engine, and exhaust can cause mechanical problems and increase the risk of fire.**

**When operating the vehicle in conditions that allow debris or flammable material to collect in and around the vehicle, inspect the engine, electrical component and exhaust areas frequently. If debris or flammable materials have collected, park the vehicle outside and stop the engine. Allow the engine to cool, then remove any collected debris. Do not park or store the vehicle in an enclosed space prior to inspecting for build-up of debris or flammable materials.**



## 160 MAINTENANCE AND ADJUSTMENT

- Be sure the engine and exhaust are cool before washing.
- Avoid applying degreaser to seals, brake pads, and tires.
- Always use non-abrasive wax and cleaner/polisher.
- Avoid all harsh chemicals, solvents, detergents, and household cleaning products such as ammonia-based window cleaners.
- Gasoline, brake fluid, and coolant will damage the finish of painted and plastic surfaces: wash them off immediately.
- Avoid wire brushes, steel wool, and all other abrasive pads or brushes.
- Use care when washing the windshield, headlight lens, and other plastic parts as they can easily be scratched.
- Avoid using pressure washers; water can penetrate seals and electrical

components and damage your motorcycle.

- Avoid spraying water in delicate areas such as in air intakes, fuel system, brake components, electrical components, muffler outlets, and fuel tank openings.

### *Washing Your Motorcycle*

- Rinse your bike with cold water from a garden hose to remove any loose dirt.
- Mix a mild neutral detergent (designed for motorcycles or automobiles) and water in a bucket. Use a soft cloth or sponge to wash your motorcycle. If needed, use a mild degreaser to remove any oil or grease which build up.
- After washing, rinse your motorcycle thoroughly with clean water to remove any residue (residue from the

detergent can damage parts of your motorcycle).

- Use a soft cloth to dry your motorcycle. As you dry, inspect your motorcycle for chips and scratches. Do not let the water air dry as this can damage the painted surfaces.
- Start the engine and let it idle for several minutes. The heat from the engine will help dry moist areas.
- Carefully ride your motorcycle at a slow speed and apply the brakes several times. This helps the brakes dry and restores its normal operating performance.
- Lubricate the drive chain to prevent rusting.

### NOTE

- *After riding in an area where the roads are salted or near the ocean, immediately wash your motorcycle with cold water. Do not use warm*

*water as it accelerates the chemical reaction of the salt. After drying, apply a corrosion protection spray on all metal and chrome surfaces to prevent corrosion.*

- *Condensation may form on the inside of the headlight lens after riding in the rain or washing the motorcycle. To remove the moisture, start the engine and turn on the headlight. Gradually the condensation on the inside of the lens will clear off.*

### Semi-gloss Finish

To clean the semi-gloss finish;

- When washing the motorcycle, always use a mild neutral detergent and water.
- The semi-gloss finish effect may be lost when the finish is excessively rubbed.
- If any doubt, consult an authorized Kawasaki dealer.

### *Painted Surfaces*

After washing your motorcycle, coat painted surfaces, both metal and plastic, with a commercially available motorcycle/automotive wax. Wax should be applied once every three months or as conditions require. Avoid surfaces with “satin” or “flat” finishes. Always use non-abrasive products and apply them according to the instructions on the container.

### *Windshield and Other Plastic Parts*

After washing use a soft cloth to gently dry plastic parts. When dry, treat the windshield, headlight lens, and other non-painted plastic parts with an approved plastic cleaner/polisher product.

## **NOTICE**

**Plastic parts may deteriorate and break if they come in contact with chemical substances or household cleaning products such as gasoline, brake fluid, window cleaners, thread-locking agents, or other harsh chemicals. If a plastic part comes in contact with any harsh chemical substance, wash it off immediately with water and a mild neutral detergent, and then inspect for damage. Avoid using abrasive pads or brushes to clean plastic parts, as they will damage the part's finish.**

### *Chrome and Aluminum*

Chrome and uncoated aluminum parts can be treated with a chrome/aluminum polish. Coated aluminum should be washed with a mild neutral detergent and finished with a spray polish. Aluminum wheels, both painted and unpainted can be cleaned with special non-acid based wheel spray cleaners.

### *Leather, Vinyl, and Rubber*

If your motorcycle has leather accessories, special care must be taken. Use a leather cleaner/treatment to clean and care for leather accessories. Washing leather parts with detergent and water will damage them, shortening their life.

Vinyl parts should be washed with the rest of the motorcycle, then treated with a vinyl treatment.

The sidewalls of tires and other rubber components should be treated with a rubber protectant to help prolong their useful life.

## **WARNING**

**Rubber protectants can be slippery and, if used on the tread area, cause loss of traction resulting in accident causing injury or death. Do not apply rubber protectant to any tread area.**

### Bolt and Nut Tightening

In accordance with the Periodic Maintenance Chart, it is very important to check the tightness of the bolts and nuts listed here. Also, check to see that each cotter pin is in place and in good condition. Please ask your authorized Kawasaki dealer for torque values.

1. Front Fender Mounting Bolts
2. Front Fork Clamp Bolts
3. Handlebar Clamp Bolts
4. Clutch Lever Holder Bolts
5. Steering Stem Head Bolt
6. Steering Stem Nut
7. Pivot Shaft Bolt
8. Step Stay Mounting Bolt
9. Front Brake Disk Mounting Bolts
10. Front Caliper Mounting Bolts
11. Engine Mounting Bolts and Nuts
12. Side Stand Bolt
13. Rear Axle Nut
14. Rear Sprocket Mounting Bolts

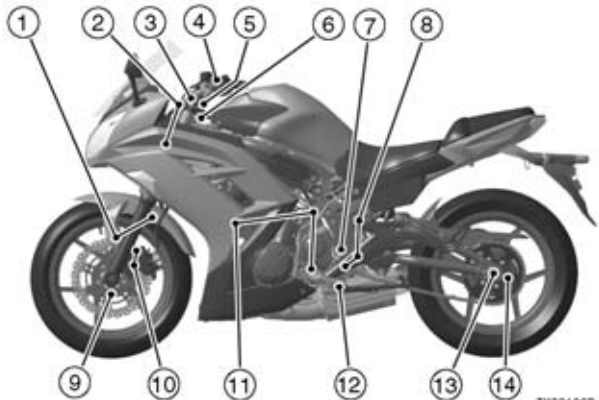

1. Rear Shock Absorber Mounting Bolts
2. Front Brake Master Cylinder Clamp Bolt
3. Rear Caliper Mounting Bolts
4. Rear Brake Disk Mounting Bolts
5. Rear Master Cylinder Mounting Bolts
6. Brake Pedal Mounting Bolt
7. Front Axle Shaft
8. Front Axle Clamp Bolt

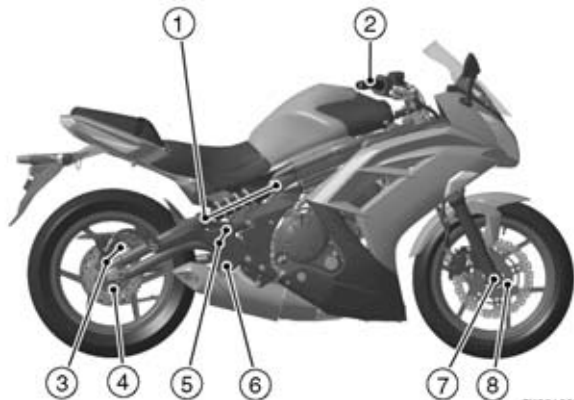

---

## STORAGE

---

### Preparation for Storage:

- Clean the entire vehicle thoroughly.
- Run the engine for about five minutes to warm the oil, shut it off, and drain the engine oil.

 <b>WARNING</b>
--

<p><b>Engine oil is a toxic substance. Dispose of used oil properly. Contact your local authorities for approved disposal methods or possible recycling.</b></p>
--

- Put in fresh engine oil.
- Empty the fuel from the fuel tank by the pump or siphon.

 **WARNING**

**Gasoline is extremely flammable and can be explosive under certain conditions, creating the potential for serious burns. Turn the ignition key to "OFF". Do not smoke. Make sure the area is well-ventilated and free from any source of flame or sparks; this includes any appliance with a pilot light. Gasoline is a toxic substance. Dispose of gasoline properly. Contact your local authorities for approved disposal methods.**

- Empty the fuel system by running the engine at idle speed until the engine stalls. (If left in for a long time, the fuel will break down and could clog the fuel system.)
- Reduce tire pressure by about 20%.
- Set the motorcycle on a box or stand so that both wheels are raised off the ground. (If this cannot be done, put boards under the front and rear wheels to keep dampness away from the tire rubber.)
- Spray oil on all unpainted metal surfaces to prevent rusting. Avoid getting oil on rubber parts or in the brakes.
- Lubricate the drive chain and all the cables.
- Remove the battery, and store it where it will not be exposed to direct sunlight, moisture, or freezing temperature. During storage it should be given a slow charge (one ampere or less) about once a month. Keep the battery well charged especially during cold weather.
- Tie plastic bags over the mufflers to prevent moisture from entering.



## 168 STORAGE

- Put a cover over the motorcycle to keep dust and dirt from accumulating on it.

### **Preparation after Storage:**

- Remove the plastic bags from the mufflers.
- Install the battery in the motorcycle and charge the battery if necessary.
- Fill the fuel tank with fuel.
- Check all the points listed in the Daily Checks section.
- Lubricate the points listed in the General Lubrication section.

---

## TROUBLESHOOTING GUIDE

---

### **Engine Does Not Start -**

#### *Starter Motor Won't Turn*

- Engine stop switch off
- Transmission not in neutral
- Fuse blown
- Battery leads do not make good electrical contact with battery terminals
- Battery discharged

#### *Engine Cranks, But Won't Start*

- No fuel in tank
- Fuel line clogged
- Fuel broken down
- Engine flooded
- Spark plugs not in good contact
- Spark plugs fouled or wet

- Incorrect spark plug gap
- Incorrect valve clearance
- No first turning the ignition key to "OFF" when the motorcycle falls down.

### **Engine Stalls -**

#### *Just When Shifting Into 1st Gear*

- Side stand has been left down
- Clutch does not properly disengage

#### *While Riding*

- No fuel in tank
- Fuel tank air vent is obstructed
- Overheating
- Battery discharged

---

## YOUR WARRANTY/OWNER SATISFACTION

---

Welcome to the Kawasaki family!

Congratulations on buying your Kawasaki vehicle. You've chosen a great, high-quality product with state-of-the-art features and built to Kawasaki's high standards. Your satisfaction is important to your authorized Kawasaki dealer and to Kawasaki Motors Corp., U.S.A. Here is some important information regarding your vehicle's limited warranty.

Frequently Asked Questions

### **What is a Limited Warranty?**

The most important thing to know about your warranty is that it protects you from manufacturing defects in material or workmanship during the warranty period. You can find the warranty period in the Kawasaki Limited Warranty Certificate your Kawasaki dealer provided to you at the time of sale. The warranty does not cover the cost of regularly-scheduled maintenance. The warranty also does not apply to the normal wear of items such as tires, brake pads, transmission drive belts, chains, sprockets, etc.

## **What is the Good Times Protection Plan?**

Much of the warranty coverage offered by the limited warranty can be extended by purchasing Kawasaki's Good Time™ Protection Plan (GTPP). See your Kawasaki dealer or go to [Kawasaki.com](http://Kawasaki.com) for more information if you don't already have the GTPP.

## **What Am I Responsible For?**

You are responsible for maintaining your vehicle according to the maintenance schedule shown in this owner's manual.

You are responsible for notifying your dealer immediately if there is a problem, and you, as the owner, will need to authorize the dealer to inspect the unit.

You will be responsible for paying for routine maintenance, including the first scheduled service. You can have the required servicing done by your Kawasaki dealer (recommended) or an equally-qualified service facility. You can also do your own maintenance work if you have the proper tools, service references, and mechanical skills. However, if a failure is found to be caused by improper servicing, it would not be covered by the limited warranty.

## **172 YOUR WARRANTY/OWNER SATISFACTION**

You may purchase a Kawasaki Service Manual and any necessary special tools directly from your Kawasaki dealer.

You will be responsible for paying for repairs needed because of an accident, to replace worn parts such as tires, chains, brakes, and for repairs needed because of a lack of maintenance, misuse or racing.

Whether you do it yourself or take your vehicle to a Kawasaki dealer, be sure to record your service in the Maintenance Record section of this Owner's Manual. Keep all receipts for the service and/or items necessary to perform the maintenance so that in the event of a failure you can document the service history.

### **What Are The Dealership's Responsibilities?**

Your Kawasaki dealer offers a wide range of services, parts, accessories, and information on your product and on Kawasaki.

Each dealer is independently owned and operated and is responsible for the dealership's operations, its repair, warranty, and service work, and its personnel.

Your dealer is responsible for completing the set up and pre-delivery service of your new Kawasaki vehicle. The dealership should also explain its operation, maintenance, and warranty provisions so you understand them at the time of purchase or at any other time you have questions.

The dealership is responsible for inspecting your Kawasaki vehicle if there is a failure, investigating the cause of the problem, and getting any needed authorization from Kawasaki if the repair is one that will be covered by the limited warranty. The dealership will also file all necessary paperwork. The dealership is responsible for correctly completing any necessary repairs, whether they are covered by the limited warranty or not.

### **How Do I Get Warranty Service?**

If there is a problem with your vehicle within the limited warranty period, you will need to schedule a service appointment and provide any maintenance records to an authorized Kawasaki dealer for inspection and diagnosis. You can go to any Kawasaki dealer for warranty repairs. Your Kawasaki dealer will inspect your vehicle and give you the results of the inspection. The dealer will perform the repairs at no cost to you if it is determined that the problem is covered by the warranty.

## **174 YOUR WARRANTY/OWNER SATISFACTION**

Kawasaki will work with your dealer to resolve any warranty issues. No authorization for warranty work can be given until your vehicle has been inspected by a Kawasaki dealer.

### **What if I am not Satisfied With My Warranty Service?**

If you aren't satisfied with your dealership's repair work or operations, it is best to discuss the situation with the appropriate dealership manager. If you have already done this, then contact the dealership's owner or general manager to request a review of the issue.

If you are unable to resolve a problem after consulting with the dealership management and need further assistance, contact Kawasaki Motors Corp., U.S.A. at the address below. Please be certain to provide the model, vehicle identification number (VIN), mileage or hours of use, accessories, dates that events occurred and what action has been taken by both you and your dealer. Include the name and address of the dealership. To assist us in resolving your inquiry, please include copies of related receipts and any other pertinent information including the name of the dealership personnel with whom you have been working. Upon receipt of your correspondence, Kawasaki Motors Corp., U.S.A. will contact the dealership and work with it in resolving your problem.

## **Want to Contact Kawasaki?**

This owner's manual should answer most of your questions about your Kawasaki. Your Kawasaki dealer should either be able to answer any other questions you might have immediately or be able to find the answer for you.

Please send your correspondence to:

Consumer Services

Kawasaki Motors Corp., U.S.A.

P.O. Box 25252

Santa Ana, CA 92799-5252

(949) 460-5688



---

## REPORTING SAFETY DEFECTS

---

### **(For Products Sold in the United States of America, District of Columbia, and U.S. Territories Only)**

If you believe that your vehicle has a defect which could cause a crash or could cause injury or death, you should immediately inform the National Highway Traffic Safety Administration (NHTSA) in addition to notifying Kawasaki Motors Corporation, U.S.A.

If NHTSA receives similar complaints, it may open an investigation, and if it finds that a safety defect exists in a group of vehicles, it may order a recall and remedy campaign. However, NHTSA cannot become involved in individual problems between you, your dealer, or Kawasaki Motors Corporation, U.S.A.

To contact NHTSA, you may either call the Auto Safety Hotline toll-free at 1-800-424-9393 (or 366-0123 in Washington, D.C. area) or write to: NHTSA, U.S. Department of Transportation, Washington, D.C. 20590. You can also obtain other information about motor vehicle safety from the Hotline.

---

## ENVIRONMENTAL PROTECTION

---

To help preserve the environment, properly discard used batteries, tires, oils and fluids, or other vehicle components that you might dispose of in the future. Consult your authorized Kawasaki dealer or local environmental waste agency for their proper disposal procedure. This also applies to disposal of the entire vehicle at the end of its life.

---

**MAINTENANCE RECORD**

---

Owner Name.....

Address .....

Phone Number .....

Engine Number .....

Vehicle Number.....

Key Code .....

Selling Dealer Name .....

Phone Number .....

Warranty Start Date .....

**Note:** Keep this information and a spare key in a secure location.

Date	Odometer Reading	Maintenance Performed	Dealer Name	Dealer Address

















---

## LOCATION OF LABELS

---

All warning labels which are on your vehicle are repeated here. Read labels on your vehicle and understand them thoroughly. They contain information which is important for your safety and the safety of anyone else who may operate your vehicle. Therefore, it is very important that all warning labels be on your vehicle in the locations shown. If any label is missing, damaged, or worn, get a replacement from your Kawasaki dealer and install it in the correct position.

### NOTE

- *The sample warning labels in this section have part numbers to help you and your dealer obtain the correct replacement.*

- *Refer to the actual vehicle label for model specific data grayed out in the illustration.*

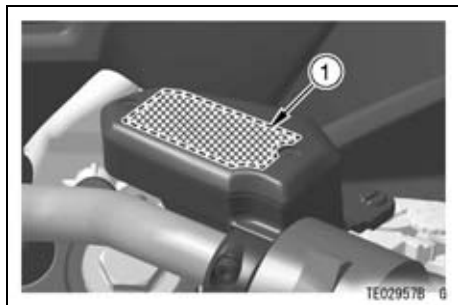

**1. Brake Fluid (Front)**

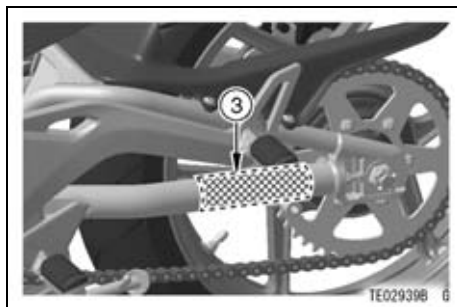
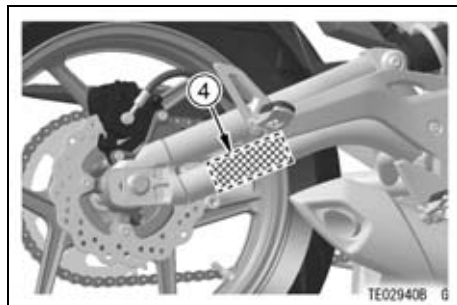
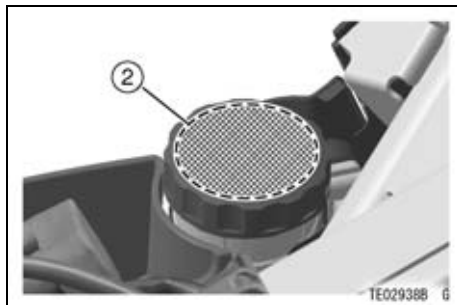

- 2. Brake Fluid (Rear)
- 3. Important Drive Chain Information
- 4. Tire and Load Data

## 188 LOCATION OF LABELS

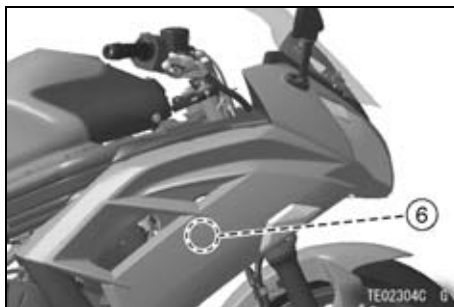
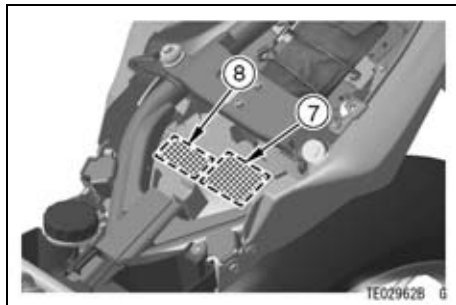
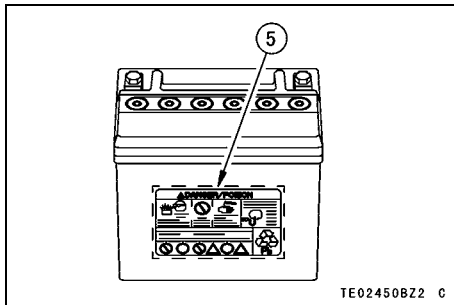

- 5. Battery Poison/Danger
- 6. Radiator Cap Danger
- 7. Vehicle Emission Control Information
- 8. Noise Emission Control Information

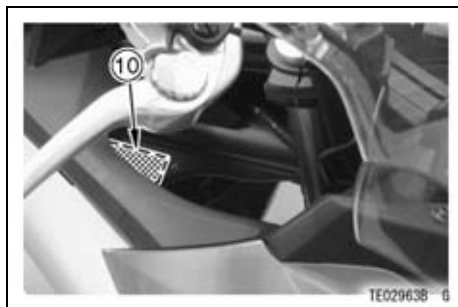
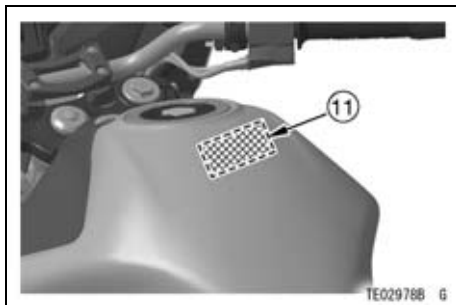
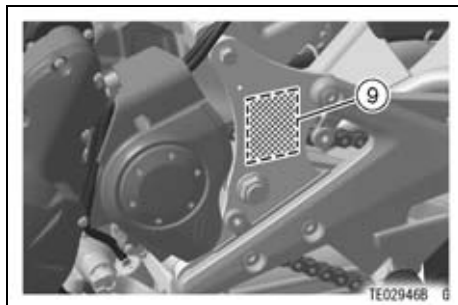

- \*9. Vacuum Hose Routing Diagram
- 10. Weight and Manufacture
- \*11. Fuel Notice

\*: only on California model

## 190 LOCATION OF LABELS

(1)

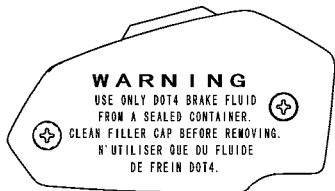

TE03841BN9 C

(2)

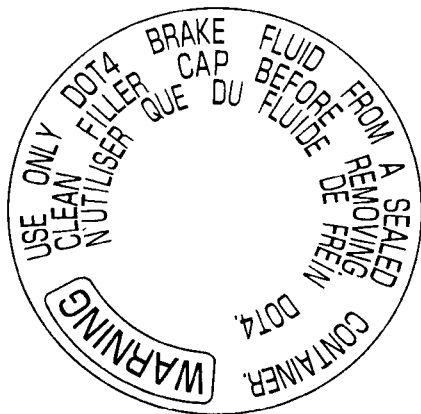

TE03097B S

(3)

### IMPORTANT DRIVE CHAIN INFORMATION

To prevent an accident and/or damage to the motorcycle, the drive chain must be properly maintained. It should be lubricated every 600km(400mi) and adjusted as often as necessary to keep chain slack at about 25~35mm(1.0~1.4in) measured midway between sprockets on the lower chain run with the motorcycle on the side stand. The standard chain is an DAIDO D10520VP2 with estimated service life of 15000~45000km(9400~28000mi), depending on the severity of use and the frequency of lubrication and adjustment. For safety, replace the chain with only the standard chain any time it wears to over 323mm(12.7in), measured over a 20-link portion pulled straight with 98N(10kgf, 20lbf) of tension. See the Owner's Manual for chain information.

56033-0252

TE03107DN8 C

(4)

TIRE AND LOAD DATA			
The stability and handling characteristics of this motorcycle could become unsafe by the use of improper tire inflation pressures, overrated tires, unsuitable replacement tires, or overloading. When tire tread wears down to the limit, replace the tire with only the standard tire. Maintain the inflation pressure specified.			
Air Pressure(kgf)	Size & Make Type (Tubeless Tire)	Minimum Tread Depth	
Front	Up to 200kg Load (440lbs)	2.50 LF (12.589in)	1 mm(0.04in)
	250 LF (12.589in)	1.75 LF (6.889in)	
REAR	Up to 200kg Load (440lbs)	2.50 LF (12.589in)	1.75 LF (6.889in)
	250 LF (12.589in)	1.75 LF (6.889in)	1.75 LF (6.889in)

56053-0626

(5)

**⚠ DANGER/POISON**

 <b>SHIELD EYES</b> EXPLOSIVE GASES CAN CAUSE BLINDNESS OR INJURY	 <b>NO</b> • SPARKS • FLAMES • SMOKING → SEVERE BURNS	 <b>SULFURIC ACID</b> • CAN CAUSE BLINDNESS OR SEVERE BURNS
--	--	--

**FLUSH EYES IMMEDIATELY WITH WATER GET MEDICAL HELP FAST**

**KEEP OUT OF REACH OF CHILDREN**

IN U.S.A., SERVICED BY: **YUASA BATTERY, INC.** READING, PA. 19605







  
**RECYCLE**  
**Pb**

TE03478D S

TE03481D S





(9) only on California model

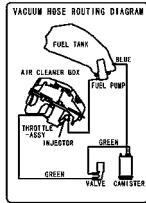

TE03483DN9 C

(11) only on California model

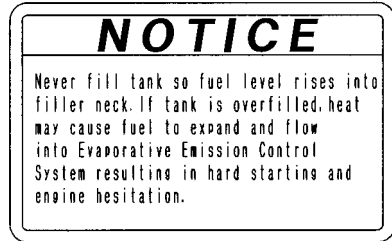

56071-0158

TE03715D S

(10)

MFD. BY KAWASAKI HEAVY INDUSTRIES, LTD.  
 DATE: [ ] THIS VEHICLE CONFORMS  
 TO ALL APPLICABLE FEDERAL MOTOR VEHICLE  
 SAFETY STANDARDS IN EFFECT ON THE DATE  
 OF MANUFACTURE SHOWN ABOVE. GVWR [ ] LBS.  
 GAWR F [ ] LBS. WITH [ ]  
 TIRE, [ ] RIM, AT [ ] PSI, COLD.  
 GAWR R [ ] LBS. WITH [ ]  
 TIRE, [ ] RIM, AT [ ] PSI, COLD.  
 [ ]  
 MOTOR CYCLE [ ] MADE IN THAILAND

TE03442DN9 C

**EX650EE**

**EX650FE**



\* 9 9 9 8 7 - 1 7 9 7 \*



**KAWASAKI HEAVY INDUSTRIES, LTD.**

Motorcycle & Engine Company

Part No. 99987-1797

Printed in Thailand

GB