

KLX140
KLX140L

Motorcycle

OWNER'S MANUAL

 Read this manual carefully. It contains safety information.

Kawasaki

Quick Reference Guide

This Quick Reference Guide will assist you in finding the information you're looking for.

GENERAL INFORMATION

MAINTENANCE AND ADJUSTMENT

TROUBLESHOOTING GUIDE

STORAGE

A Table of Contents is included after the Foreword.

IMPORTANT INFORMATION

- This vehicle is designed for the operator only, no passengers.
- This vehicle is an off-road motorcycle only and was not manufactured for use on public streets, roads or highways.
- Respect the environment and the rights of other people.
- Read owner's manual.

Whenever you see the symbols shown below, heed their instructions! Always follow safe operating and maintenance practices.

 **DANGER**

DANGER indicates a hazardous situation which, if not avoided, will result in death or serious injury.

 **WARNING**

WARNING indicates a hazardous situation which, if not avoided, could result in death or serious injury.

NOTICE

NOTICE is used to address practices not related to personal injury.

NOTE

○ *NOTE* indicates information that may help or guide you in the operation or service of the vehicle.

IMPORTANT

Off-road motorcycling is a wonderful sport, and we hope you will enjoy it to the fullest. However, if improperly conducted, this sport has the potential to cause environmental problems as well as conflicts with other people.

Responsible use of your off-road motorcycle will ensure that these problems and conflicts do not occur. **TO PROTECT THE FUTURE OF YOUR SPORT, MAKE SURE YOU USE YOUR MOTORCYCLE LEGALLY, SHOW CONCERN FOR THE ENVIRONMENT, AND RESPECT THE RIGHTS OF OTHER PEOPLE.**

WARNING

- **THIS VEHICLE IS AN OFF-ROAD VEHICLE ONLY AND WAS NOT MANUFACTURED FOR USE ON PUBLIC STREETS, ROADS, OR HIGH-WAYS.**
- **USE YOUR BIKE LEGALLY.**
- **RESPECT THE ENVIRONMENT AND THE RIGHTS OF OTHER PEOPLE.**

IMPORTANT NOTE TO PARENTS ABOUT SAFE RIDING

Your youngster's safety will depend on your commitment to always provide a safe riding environment and a properly maintained vehicle. As with any moving vehicle there are possible safety risks; be sure to heed these precautions.

1. Always equip your child with suitable protective gear and riding apparel. Be sure he or she always wears a helmet, over-the-ankle footwear or sturdy boots, eye protection, gloves, long pants, and a long-sleeved shirt while riding.
2. Never allow your child to carry a passenger. This motorcycle is designed for an OPERATOR ONLY.
3. This motorcycle is designed for off-road riding and should never be operated on public roads or paved surfaces.
4. This motorcycle was not designed for hard riding such as motocross.
5. Always obey local off-road riding laws and regulations. Obtain permission to ride on private property.
6. You, the parent (and most likely "riding instructor/mechanic" as well), must be familiar with motorcycle controls and maintenance requirements plus riding techniques. Read and understand the owner's manual provided with the motorcycle. Review all instructions and warnings with your child.
7. You must determine your child's readiness to ride this off-road motorcycle. Your child should already be familiar with motorcycle controls (location and function) and basic riding techniques. Your child should also be physically large enough, and strong enough to be able to straddle the motorcycle and hold it up, plus be able to pick up it up if it is on its side.
8. Your child's safety depends in part on the good mechanical condition of the motorcycle. Be sure to follow the maintenance and adjustment requirements contained in the Periodic Maintenance Chart, Daily Pre-ride Inspection, and After-Race Check Points. Be sure your child understands the importance of checking all items thoroughly before riding the motorcycle. Also, familiarity with the motorcycle is important should a problem occur far from help.
9. Do not allow your child to ride unsupervised. He or she should always ride in the company of an experienced adult.

10. Encourage your child not to ride beyond his or her skill level or faster than conditions safely allow. Have them practice advanced riding maneuvers under controlled conditions.
11. Tell someone where you and your child are planning to ride and when you intend to return. Discuss the ride with your child before you leave so he or she will know in advance what riding techniques may be necessary to negotiate the terrain safely. If you are not familiar with the area, lead the way and reduce your speed.

KLX140A only

NOTICE

KLX140A is designed for a rider weighting less than 70 kg (154 pounds). Exceeding this limit could damage the motorcycle.

PLEASE DO NOT TAMPER WITH NOISE CONTROL SYSTEM

To minimize the noise emissions from this product, Kawasaki has equipped it with effective intake and exhaust silencing system. They are designed to give optimum performance while maintaining a low noise level. Please do not remove these systems, or alter them in any way which results in an increase in noise level.

FOREWORD

We wish to thank you for choosing this Kawasaki Motorcycle. It is the end product of Kawasaki's advanced engineering, exhaustive testing, and continuous striving for superior reliability, and performance. By giving your motorcycle the proper care and maintenance outlined in this manual, you will be helping to ensure it a long, trouble-free life.

Before starting to ride your motorcycle, please read this manual thoroughly in order to know your motorcycle's capabilities, its limitations, and above all, how to operate it safely.

Due to improvements in design and performance made during production, in some cases there may be minor discrepancies between the actual vehicle and the illustrations and text in this manual.

KAWASAKI HEAVY INDUSTRIES, LTD.
Motorcycle & Engine Company

©2014 Kawasaki Heavy Industries, Ltd.

Feb. 22, 2014. (1)

TABLE OF CONTENTS

SPECIFICATIONS	10	Clutch	53
GENERAL INFORMATION	13	Valve Clearance	55
Location of Labels	13	Spark Arrester	55
Location of Parts	18	Drive Chain.....	57
Side Stand	21	Handlebar	63
Fuel	21	Brakes	65
Engine Stop Switch	24	Steering	68
Starter Button	25	Front Suspension	70
Starting the Engine	25	Rear Suspension.....	71
Moving Off	28	Wheels	74
Shifting Gears.....	28	Hoses Inspection	77
Stopping the Motorcycle.....	29	Battery	78
Stopping the Engine	30	Fuse	82
Break-In.....	30	Tightening Torques of Nuts and Bolts.....	83
Daily Pre-Ride Checks	31	Cleaning Your Motorcycle.....	88
MAINTENANCE AND ADJUSTMENT	33	Lubrication	91
Periodic Maintenance Chart	33	TROUBLESHOOTING GUIDE	94
Engine Oil.....	38	STORAGE	96
Spark Plug	42	Before Storage	96
Air Cleaner	43	After Storage	97
Throttle Cable.....	48	ENVIRONMENTAL PROTECTION	98
Choke Knob.....	51	WIRING DIAGRAM	99
Idle Speed	52		

SPECIFICATIONS

DIMENSIONS

Overall length	1 820 mm (71.7 in.)	B: 1 895 mm (74.6 in.)
Overall width	790 mm (31.1 in.)	
Overall height	1 050 mm (41.3 in.)	B: 1 075 mm (42.3 in.)
Wheelbase	1 260 mm (49.6 in.)	B: 1 285 mm (50.6 in.)
Road clearance	235 mm (9.3 in.)	B: 255 mm (10.0 in.)
Curb Mass	93 kg (205 lb)	B: 95 kg (209 lb)
Fuel tank capacity	5.8 L (1.5 US gal)	

ENGINE

Type	SOHC, 2-valve, single-cylinder, 4-stroke, Air-cooled
Bore × stroke	58.0 × 54.4 mm (2.3 × 2.1 in.)
Displacement	144 cm ³ (8.8 cu in.)
Compression ratio	9.5 : 1
Carburetor	KEIHIN PB20
Starting system	Electric Starter
Ignition system	CDI
Ignition timing	10° BTDC @1 400 r/min (rpm) ~ 30° BTDC @4 000 r/min (rpm)
Lubrication system	Forced lubrication (wet sump)
Spark plug	NGK CR7HSA
Spark plug terminal	Screw type

TRANSMISSION

Transmission type	5-speed, constant mesh, return shift
Clutch type	Wet, multi disc
Drive system	Chain drive
Gear ratios:	
1st gear	2.667 (40/15)
2nd gear	1.895 (36/19)
3rd gear	1.474 (28/19)
4th gear	1.182 (26/22)
5th gear	1.000 (24/24)
Primary reduction ratio	2.880 (72/25)
Final reduction ratio	3.571 (50/14)
Overall ratio (top gear)	10.286
Engine oil:	
Capacity	1.1 L (1.2 US qt)
Type	API SG, SH, SJ, SL or SM with JASO MA, MA1 or MA2
Viscosity	SAE 10W-40

FRAME

Type	Tubular, semi-double cradle
Steering angle	41° to either side
Caster	27°
Trail	85 mm (3.3 in.)
	B: 96 mm (3.8 in.)

12 SPECIFICATIONS

Tire size, type:

Front 70/100-17 40M, IRC., LTD. IX05H
B: 70/100-19 42M, IRC., LTD. IX05H

Rear 90/100-14 49M, IRC., LTD. IX05H
B: 90/100-16 52M, IRC., LTD. IX05H

Rim size:

Front 17 × 1.40 B: 19 × 1.40

Rear 14 × 1.60 B: 16 × 1.85

Suspension:

Front Telescopic fork

Rear New Uni-trak® swingarm

Front suspension travel 180 mm (7.1 in.)

Rear wheel travel 180 mm (7.1 in.)

Front fork oil:

Type Kawasaki Fork Oil SS-8

Amount (per fork leg) 296 mL (10.0 US oz) B: 290 mL (9.8 US oz)

BRAKES

Type (Front & Rear) Disc

ELECTRICAL EQUIPMENT

Battery 12 V 6 Ah

B: KLX140B

Specifications are subject to change without notice, and may not apply to every country.

GENERAL INFORMATION

Location of Labels

All warning labels which are on your vehicle are repeated here. Read labels on your vehicle and understand them thoroughly. They contain information which is important for your safety and the safety of anyone else who may operate your vehicle. Therefore, it is very important that all warning labels be on your vehicle in the locations shown. If any label is missing, damaged, or worn, get a replacement from your Kawasaki dealer and install it in the correct position.

NOTE

- *The sample warning labels in this section have part numbers to help you and your dealer obtain the correct replacement.*

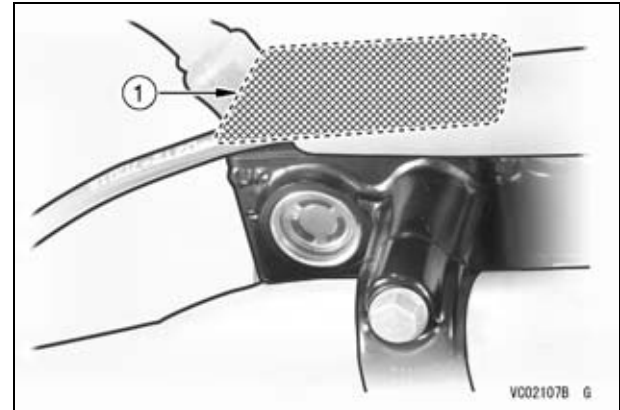

1. Brake Fluid (Front)

14 GENERAL INFORMATION

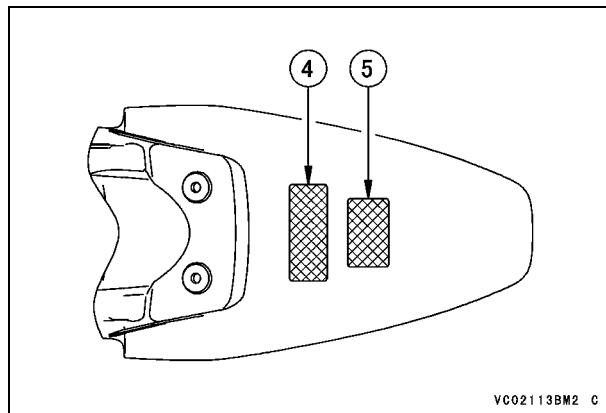
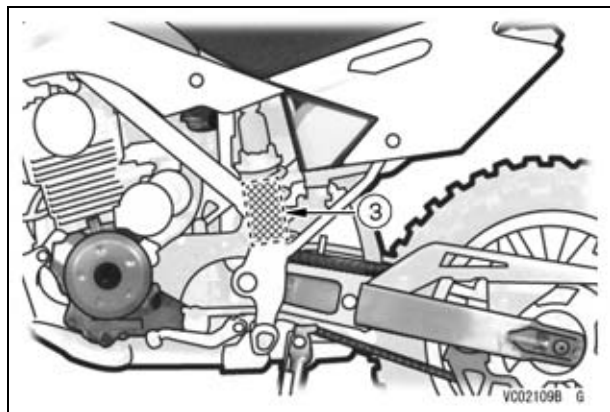
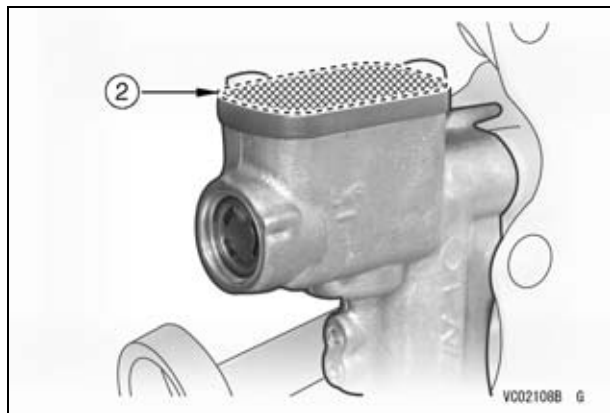

- 2. Brake Fluid (Rear)
- 3. Rear Shock Absorber Warning (KLX140A)
- 4. Important Information
- 5. Helmet (Thailand Model)

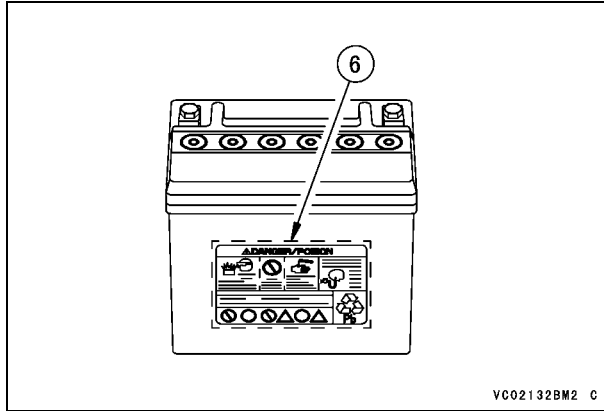

6. Battery Poison/Danger

16 GENERAL INFORMATION

1)

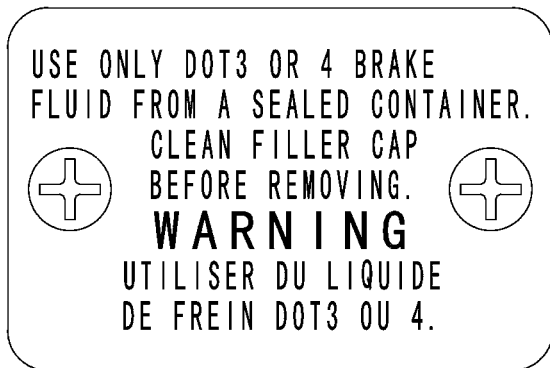

BD03298CM2 C

2)

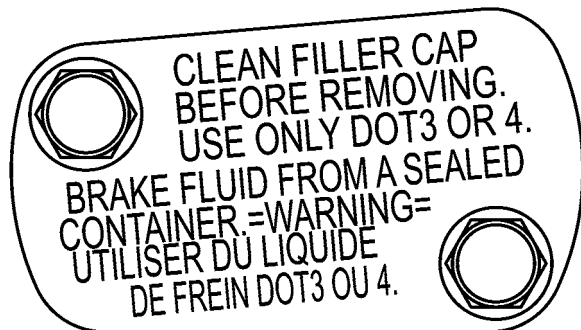

VC02096B S

3) KLX140A

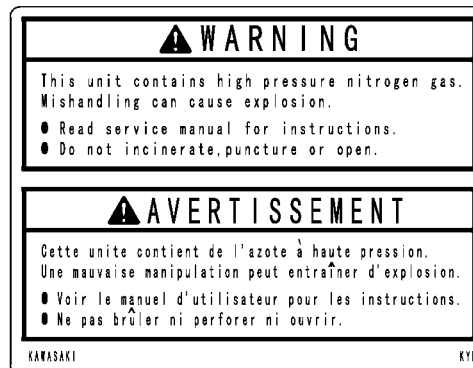

VC02097BM2 C

4)

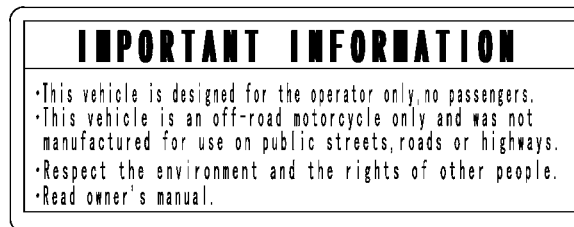

56071-0019

VC02098BM2 C

5) Thailand Model



56071-0023

VC02103B S

6)



VC02135B S

18 GENERAL INFORMATION

Location of Parts

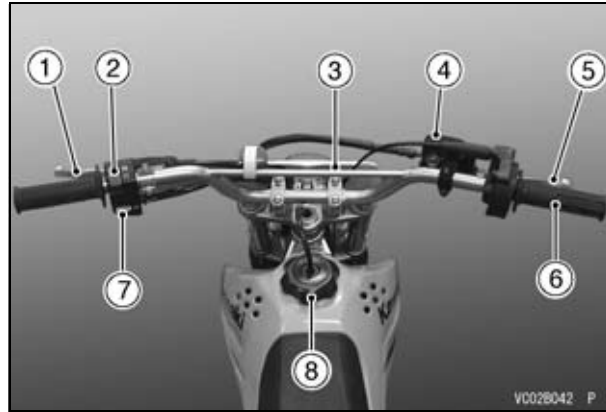

1. Clutch Lever
2. Engine Stop Switch
3. Choke Knob
4. Front Brake Fluid Reservoir

5. Front Brake Lever
6. Throttle Grip
7. Starter Button
8. Fuel Tank Cap

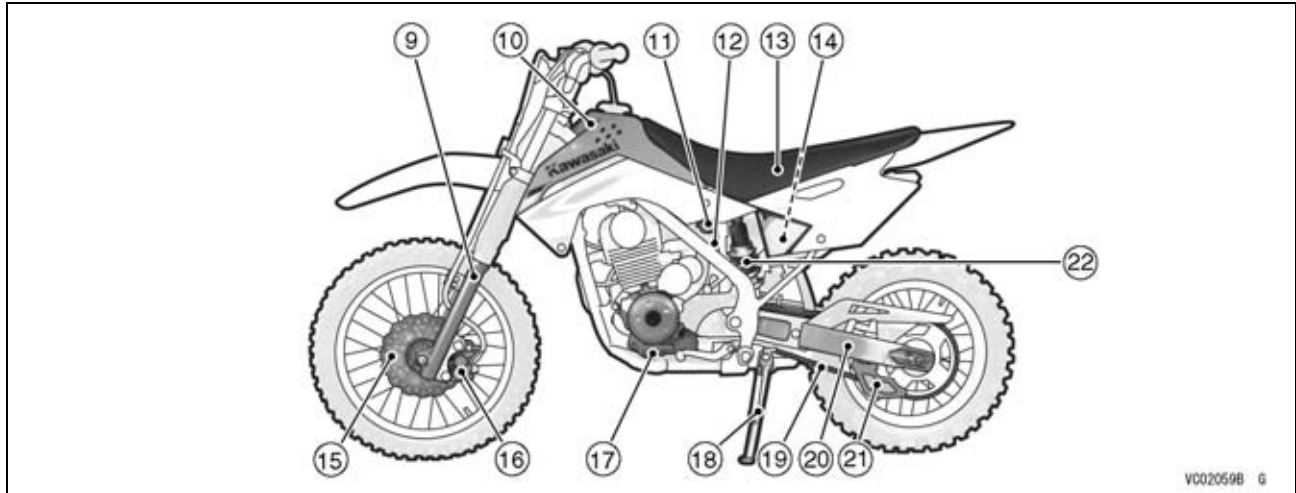

- 9. Front Fork
- 10. Fuel Tank
- 11. Fuel Tap
- 12. Carburetor
- 13. Seat
- 14. Air Cleaner Element
- 15. Brake Disc

- 16. Brake Caliper
- 17. Engine Oil Drain Plug
- 18. Side Stand
- 19. Drive Chain
- 20. Swingarm
- 21. Chain Guide
- 22. Rear Shock Absorber

20 GENERAL INFORMATION

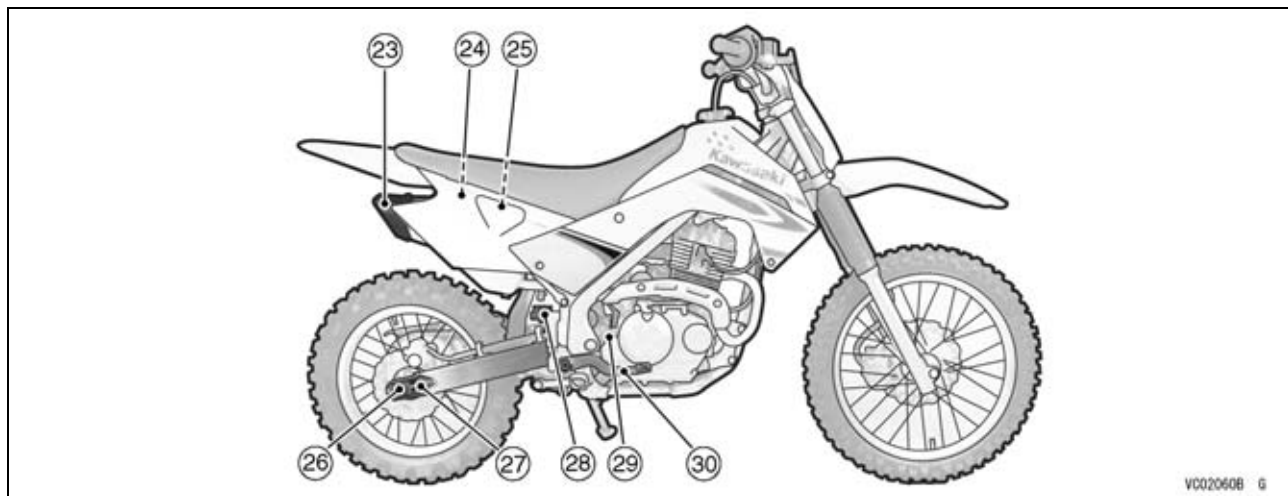

- 23. Muffler
- 24. Fuse
- 25. Battery
- 26. Rear Axle Nut

- 27. Chain Adjuster
- 28. Rear Brake Fluid Reservoir
- 29. Oil Filler Cap/Dipstick
- 30. Rear Brake Pedal

Side Stand

The motorcycle is equipped with a side stand.

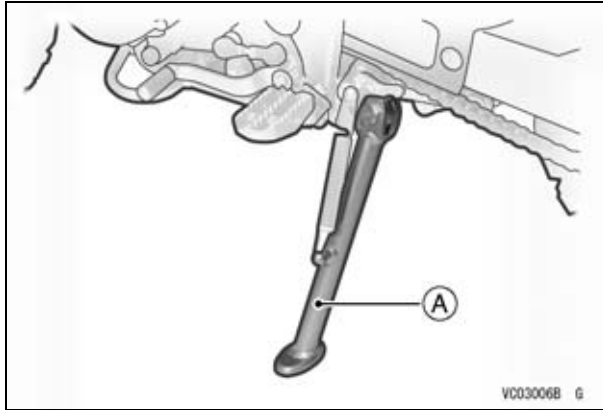

A. Side Stand

Do not sit on the motorcycle while it is on its side stand. Always kick the stand fully up before sitting on the motorcycle.

⚠ WARNING

Riding with the side stand down could cause an accident resulting in serious injury or death. Always be sure the side stand is fully raised before riding.

Fuel

Fuel Requirements:

Your Kawasaki engine is designed to use only unleaded gasoline with a minimum octane rating shown below. Never use gasoline with an octane rating lower than the minimum specified by Kawasaki to prevent severe engine damage.

The octane rating of a gasoline is a measure of its resistance to detonation or “knocking”. The term commonly used to describe a gasoline’s octane rating is the Research Octane Number (RON).

NOTICE

If engine “knocking” or “pinging” occurs, use a different brand of gasoline of a higher octane rating. If this condition is allowed to continue, it can lead to severe engine damage. Gasoline quality is important. Fuels of low quality or not meeting standard industry specifications may result in unsatisfactory performance.

22 GENERAL INFORMATION

Fuel Type and Octane Rating

Use clean, fresh unleaded gasoline with an octane rating equal to or higher than that shown in the table.

Fuel Type	Unleaded Gasoline
Ethanol Content	E10 or less
Minimum Octane Rating	Research Octane Number (RON) 91

NOTICE

Do not use any fuel that contains more ethanol or other oxygenates than specified for E10 fuel* in this vehicle. Damage to the engine and fuel system, or engine starting and/or performance problems may result from the use of improper fuel.

*E10 means fuel containing up to 10% ethanol.

NOTE

○ *In case of using E10 fuel, it is necessary to change carburetor setting.*

Filling the Tank:

Avoid filling the tank in the rain or where heavy dust is blowing so that the fuel does not get contaminated.

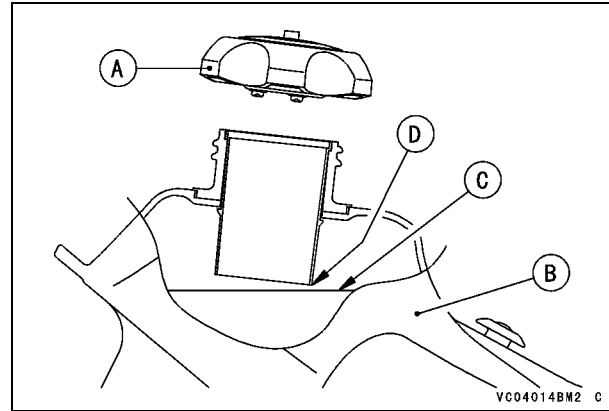

- A. Tank Cap
- B. Fuel Tank
- C. Top Level
- D. Filler Neck

⚠ WARNING

Gasoline is extremely flammable and can be explosive under certain conditions. Always stop the engine and do not smoke. Make sure the area is well ventilated and free from any source of flame or sparks; this includes any appliance with a pilot light.

Never fill the tank so the fuel level rises into the filler neck. If the tank is overfilled, heat may cause the fuel to expand and overflow through the vents in the tank cap. After refueling, make sure the fuel tank cap is closed securely. If gasoline is spilled on the fuel tank, wipe it off immediately.

NOTICE

Certain ingredients of gasoline may cause paint fading or damage. Be extra careful not to spill gasoline or gasoline oxygenates blends during refueling.

Fuel Tap:

The fuel tap has three position: OFF, ON, and RES (reserve). For normal operation, turn the fuel tap lever to the ON position. If the fuel runs out with the tap in the ON position, the last approximately 1.1 L (0.29 US gal) of usable fuel remains can be used by turning the tap lever to the RES position.

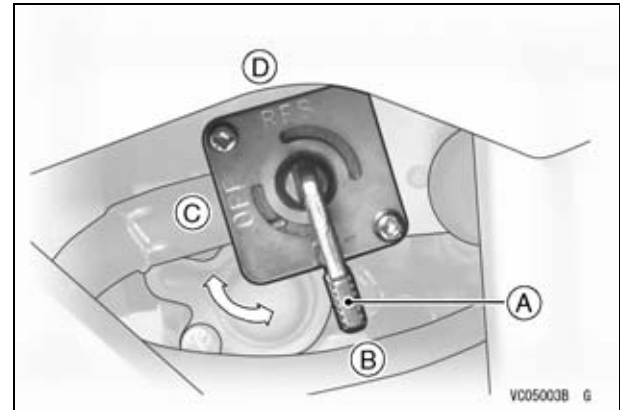

- A. Fuel Tap**
- B. ON Position**
- C. OFF Position**
- D. RES Position**

Turn the fuel tap lever to OFF position when the fuel tank is removed for maintenance and adjustments or the motorcycle is stored for a long time.

24 GENERAL INFORMATION



NOTE

- Since riding distance is limited when on RES, re-fuel at the earliest opportunity.
- Make certain that the fuel tap lever is turned to ON (not RES), after filling up the fuel tank.

WARNING

Practice operating the fuel tap with the motorcycle stopped. To prevent an accident you should be able to operate the fuel tap while riding without taking your eyes off the road. Be careful not to touch the hot engine while operating the fuel tap.

Engine Stop Switch

The engine stop switch is located on the left side of the handlebar. The engine stop switch must be in the  position for the motorcycle to operate. Move the switch to the  position to stop the engine.

NOTE

- To avoid battery discharging, check that the engine stop switch is in the  position and the indicator light (orange LED) goes off, when the motorcycle is not used.

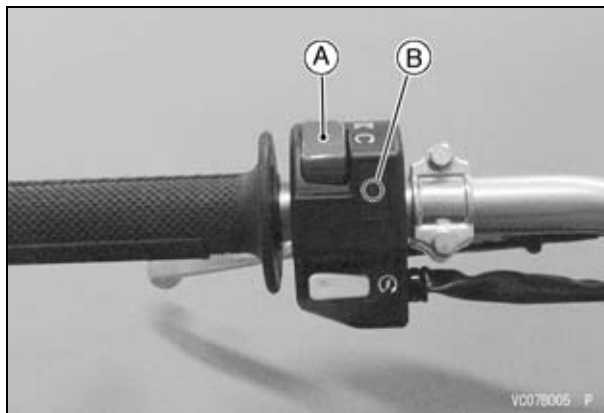

- A. Engine Stop Switch
- B. Indicator Light (LED)

Starter Button

This motorcycle has the starter button. The starter button operates the electric starter when the clutch lever pulled in.

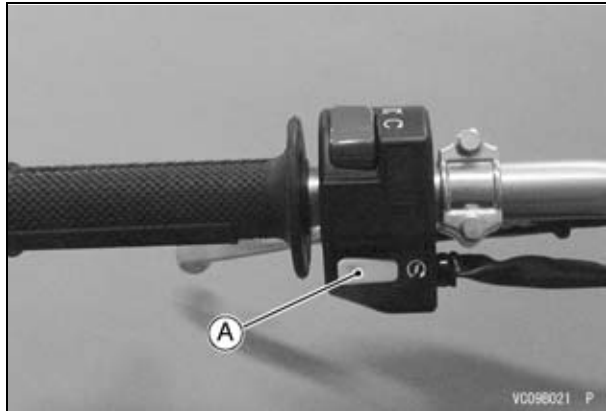

A. Starter Button

Starting the Engine

- Turn the fuel tap lever to the ON position.

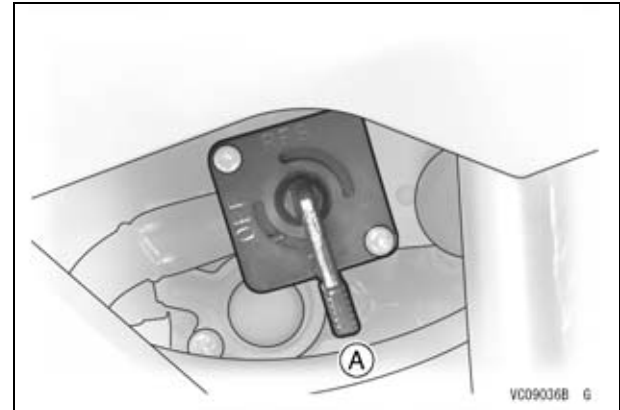

A. ON Position

- Shift the transmission into neutral.

NOTE

- *This motorcycle is equipped with a neutral switch that prevents the engine from starting when the transmission is not in neutral.*

26 GENERAL INFORMATION

- Check that the engine stop switch is in the  position.

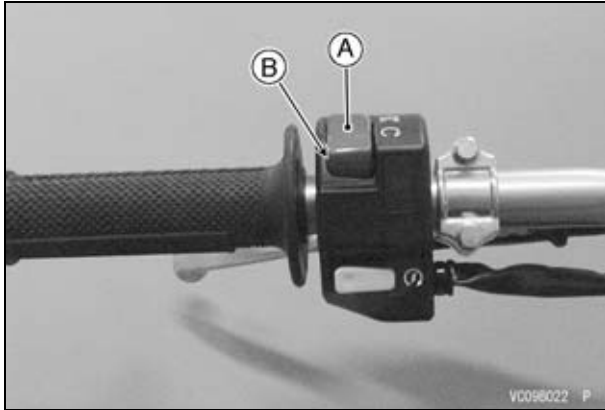

A. Engine Stop Switch

B.  Position

WARNING

Riding with the side stand in the down position can cause a crash resulting in injury. Do not start the engine or attempt to ride the motorcycle when the side stand is down.

NOTICE

Do not operate the starter continuously for more than 5 seconds, or the starter will overheat and the battery power will drop temporarily.

Wait 15 seconds between each operation of the starter to let it cool and the battery power recover.

When engine is cold:

- Pull out the choke knob.

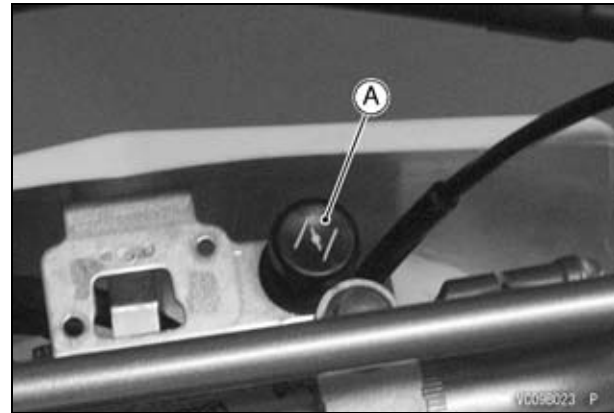

A. Choke Knob

- Leaving the throttle completely closed, push the starter button until the engine starts.

NOTICE

Do not let the engine idle longer than five minutes, or engine overheating and damage may occur.

NOTE

- *When the clutch lever is pulled, the motorcycle can be started with the transmission in any gear.*

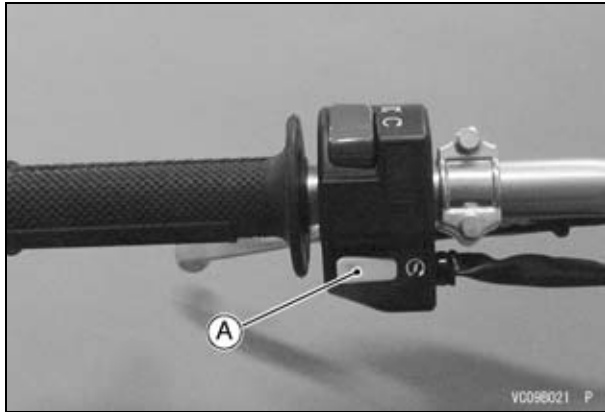
**A. Starter Button**

- Even after the engine has started, do not push back immediately the choke knob until the engine is thoroughly warmed up.

NOTE

- *When the engine is already warm or on a hot day, open the throttle part way instead of using the choke knob.*

Moving Off

- Check that the side stand is up.
- Shift into 1st gear.
- Open the throttle slowly.

Shifting Gears

This motorcycle is equipped with a 5-speed “return shift” transmission. The neutral is located halfway between 1st and 2nd gear. “Return shift” means that when shifting up or down, each gear must be engaged before the next higher or lower gear may be selected.

- To engage first gear from the neutral position, pull in the clutch lever and push down on the shift pedal, gently release the clutch lever, then release the shift pedal.
- To shift up to the next gear, pull in the clutch lever, lift the shift pedal with your toes, gently release the clutch lever, and then release the shift pedal.
- To shift down to the next gear, pull in the clutch lever, push the shift pedal down as far as it will go, gently release the clutch lever, then release the shift pedal.

WARNING

Downshifting to a lower gear at high speed causes engine rpm to increase excessively, potentially damaging the engine and it may also cause the rear wheel to skid and cause an accident.

NOTICE

When changing gears, press firmly on the shift pedal to ensure proper shifting. Careless, incomplete shifting can cause the transmission to jump out of gear and lead to engine damage.

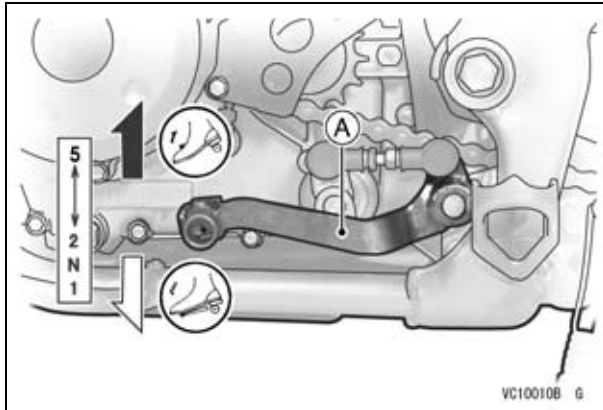

A. Shift Pedal

Stopping the Motorcycle

For maximum deceleration, close the throttle and apply both front and rear brakes. Pull in the clutch lever as the motorcycle comes to a stop. Independent use of the front or rear brake may be advantageous in certain circumstances. Shift down progressively to ensure good engine response at all speeds.

30 GENERAL INFORMATION

Stopping the Engine

- Shift the transmission into the neutral position.
- Close the throttle completely.
- Push the engine stop switch to the  position.

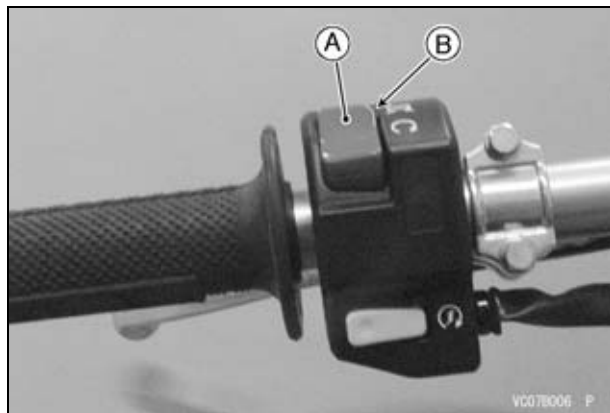

A. Engine Stop Switch

B.  Position

- Turn the fuel tap lever to the OFF position.

NOTE

- *To avoid battery discharging, check that the engine stop switch is in the  position and the indicator light (orange LED) goes off, when the motorcycle is not used.*

Break-In

The first one hour that the motorcycle is ridden is designed as the break-in period. If the motorcycle is not used carefully during this period, you may very well end up with a “broken down” instead of a “broken in” motorcycle after the long use.

Do not start moving or race the engine immediately after starting it, even if the engine is already warm. Run the engine for two or three minutes at idle speed to give the oil a chance to work up into all the engine parts.

Avoid the quick acceleration or starting and drive prudently for the first one hour of operation. Let the motorcycle cool completely. The motorcycle is ready for regular operation after this procedure is carried out.

Daily Pre-Ride Checks

Check the following items each day before you ride. The time required is minimal, and habitual performance of these checks will help ensure a safe, reliable ride.

If any irregularities are found during these checks, refer to the appropriate section and take the action required to return the motorcycle to a safe operating condition.

WARNING

Failure to perform these checks before operation may result in serious damage or an accident. Always perform daily checks before operation.

DANGER

Exhaust gas contains carbon monoxide, a colorless, odorless poisonous gas. Inhaling carbon monoxide can cause serious brain injury or death. Do not run the engine in enclosed areas. Operate only in a well-ventilated area.

Engine

Engine Oil	No leakage Level correct
Clutch	Functions properly
Spark Plug	Correctly torqued
Carburetor	Properly adjusted Idle speed: 1 350 ~ 1 450 r/min (rpm)
Air Cleaner	Clean Apply oil to air cleaner element if dry Properly installed
Muffler	No damage Properly installed
Engine sproket	Not worn or damaged

32 GENERAL INFORMATION

Frame

Tires	Overall condition good No wear or damage Air pressure correct Air valve cap installed
Spokes	No looseness
Drive Chain	Overall condition good Chain slack correct Oil if necessary
Front and Rear Brakes	Function properly Lever and pedal play correct No leakage
Throttle	Functions properly Throttle grip returns smoothly
Steering	Smooth but not loose from lock to lock No binding due to control cables
Front Fork	Functions properly No leakage
Rear Shock Absorber	Functions properly No leakage
Fuel Tank	Mounted securely No leakage
Rear Sprocket	No wear or damage
Electrical equipment	Functions properly
Engine Stop Switch	Functions properly
Nuts, Bolts, Fasteners	Properly tightened

MAINTENANCE AND ADJUSTMENT

Periodic Maintenance Chart

The maintenance and adjustments outlined in this chapter are easily carried out and must be done in accordance with the Periodic Maintenance Chart to keep the motorcycle in good running condition.

- † : Replace, add, adjust, clean or torque if necessary.
- (K) : Should be serviced by referring to the Service Manual or an authorized Kawasaki dealer.
- : Emission-related Item

34 MAINTENANCE AND ADJUSTMENT

1. Periodic Inspection (Engine Related Item)

OPERATION		FREQUENCY	Every			See Page
		Initial	50 hours (6 months)	100 hours (12 months)	5 hours (1 month)	
E N G I N E	○ Spark plug - clean, gap †		●	●		42
	(K) Clutch and friction plate - inspect †	●	●	●		–
	Clutch cable - adjust †	●	●	●		53
	(K) Valve clearance - inspect †	●		●		55
	○ Air cleaner element - clean †	●	●	●		46
	○ Throttle grip play - inspect †	●	●	●		48
	(K) Fuel tap - clean		●	●		–
	Spark arrester - clean			●		55
	Engine sprocket - inspect †			●	●	62
(K) Fuel hose connections - inspect †			●	●	77	

2. Periodic Inspection (Chassis Related Item)

OPERATION		FREQUENCY	Initial	Every		See Page
			5 hours (1 month)	50 hours (6 months)	100 hours (12 months)	
C H A S S I S	Brake adjustment - inspect †		●	●	●	65
	Brake fluid level - check †		●	●	●	66
	Brake pad wear - check †		●	●	●	68
	Brake hoses connections - check †		●	●	●	77
	Spoke tightness and rim runout - check †		●	●	●	75, 76
	Drive chain wear - check †		●	●	●	59
	Drive chain - inspect and adjust †		●	●	●	58
	Drive chain - lubricate		●	●	●	62
	Drive chain guide and slipper - inspect †		●	●	●	61
	(K) Front fork - inspect and clean †			●	●	70
	(K) Front fork oil - inspect †		Every year			–
	Nuts, bolts, fasteners - inspect †		●	●	●	83
	Steering play - inspect †		●	●	●	68
	(K) Steering stem bearing - grease				●	–
Rear sprocket - inspect †			●	●	62	

36 MAINTENANCE AND ADJUSTMENT

OPERATION		FREQUENCY	Every			See Page
		Initial 5 hours (1 month)	50 hours (6 months)	100 hours (12 months)		
C H A S S I S	Battery - inspect †		●	●		78
	Battery terminal - inspect †		●	●		80
	Chassis parts - lubricate	●	●	●		91
	Side stand - inspect †	●		●		–
	(K) Wheel bearing - check †		●	●		–
	(K) Swingarm and Uni-track linkage pivot - inspect		●	●		–
	(K) Swingarm and Uni-track linkage pivot - grease		●	●		–
	(K) Rear shock absorber - inspect †		●	●		71
	Frame - inspect and clean	●	●	●		88
	Wheels/tires - inspect †	●	●	●		74
(K) Shift pedal ball joint - inspect	●		●		88	
(K) Shift pedal pivot - grease		●	●		–	

3. Periodic Replacement (Engine and Chassis Related Item)

OPERATION	FREQUENCY	Every			See Page
	Initial	50 hours (6 months)	100 hours (12 months)		
Engine oil - change	●	●	●	39	
Oil filter - replace	●	●	●	39	
(K) Brake hose - replace		Every 4 years			-
(K) Fuel hose - replace		Every 5 years			-
(K) Brake fluid - change		Every 2 years			65
(K) Brake master cylinder cup and dust seal - replace		Every 2 years			-
(K) Brake caliper piston seal and dust seal - replace		Every 2 years			-
(K) Front fork oil - change		●	●	-	
(K) Rear shock oil - change		●	●	-	

38 MAINTENANCE AND ADJUSTMENT

Engine Oil

In order for the engine, transmission and clutch to function properly, maintain the engine oil at the proper level, and change the oil and oil filter periodically.

Not only do dirt and metal particles collect in the oil, but the oil itself loses its lubricative quality if used too long.

⚠ WARNING

Motorcycle operation with insufficient, deteriorated, or contaminated engine oil will cause accelerated wear and may result in engine or transmission seizure, accident, and injury. Check the oil level before each ride and change the oil according to the periodic maintenance chart in the Owner's Manual.

Oil Level Inspection

- Situate the motorcycle so that it is perpendicular to the ground.
- If the oil has just been changed, start the engine and run it for several minutes at idle speed. This fills the oil filter with oil.
- Stop the engine and wait several minutes for the oil to settle.

NOTICE

Racing the engine before the oil reaches every part can cause engine seizure.

- If the motorcycle has just been used, wait several minutes for all the oil to drain down.
- With the motorcycle held level, unscrew the oil filler cap/dipstick, wipe the dipstick on the cap dry, and reinsert it by screwing.

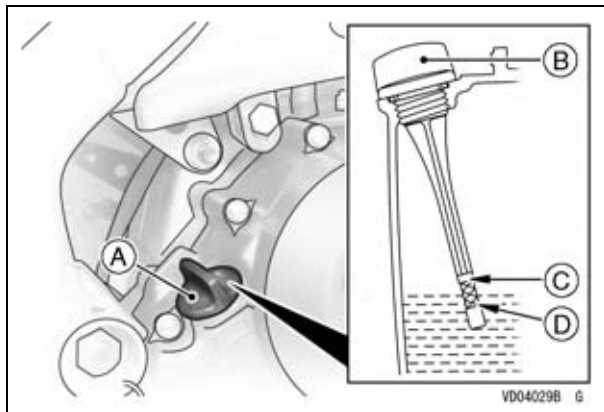

- A. Oil Filler Cap/Dipstick**
- B. Screw in the oil filler plug fully to inspect the oil level.**
- C. High Level Line**
- D. Low Level Line**

NOTICE

Be careful not to allow any dirt or foreign materials to enter the engine.

- Unscrew the cap and check the oil level by the dipstick on the cap. The oil level should be between the “H” (High) and “L” (Low) lines on the dipstick.

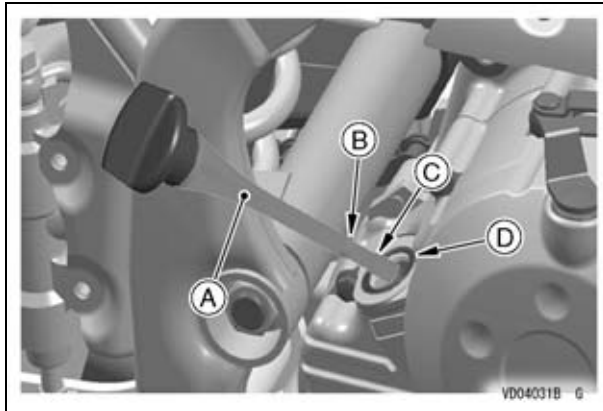

- A. Dipstick
- B. “H” (High) Line
- C. “L” (Low) Line
- D. O-ring

- If the oil level is too high, remove the excess oil through the oil filler opening using a syringe or some other suitable device.
- If the oil level is too low, add the oil to reach the correct level. Use the same type and brand of oil that is already in the engine.

NOTE

- Do not pinch the O-ring when installing the dipstick on the oil filler neck.
- When the O-ring comes off from the oil filler neck, install the O-ring on the oil filler neck correctly first, then install the dipstick.

Oil and/or Oil Filter Change

The engine oil and/or oil filter should be changed periodically to ensure long engine life.

- Warm up the engine thoroughly so that the oil will pick up any sediment and drain easily.
- Stop the engine, and place a container beneath it.
- Remove the oil filler cap/dipstick.
- Remove the oil drain plugs and position the vehicle by using the side stand to allow all the oil to drain.

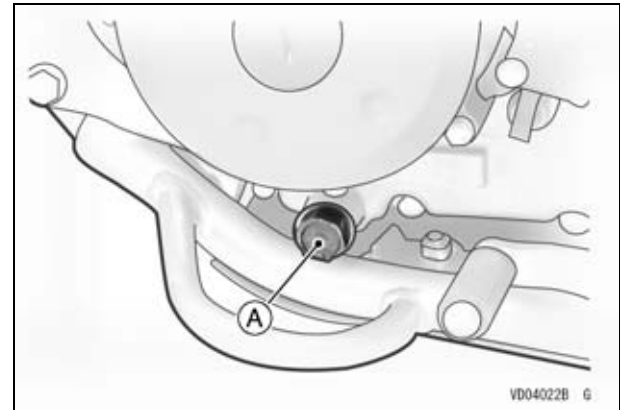

A. Drain Plug

40 MAINTENANCE AND ADJUSTMENT

⚠ WARNING

Engine oil is a toxic substance. Dispose of used oil properly. Contact your local authorities for approved disposal methods or possible recycling.

- When the oil filter is replaced, remove the oil filter cover and take off the cover with O-ring.

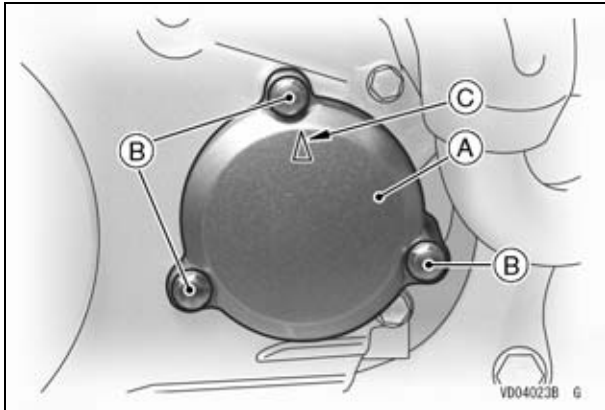

- A. Oil Filter Cover
- B. Bolts
- C. Up Mark

- Replace the oil filter element with a new one.
- Apply the grease oil to the grommet.
- Install the oil filter element with the grommet toward the engine.

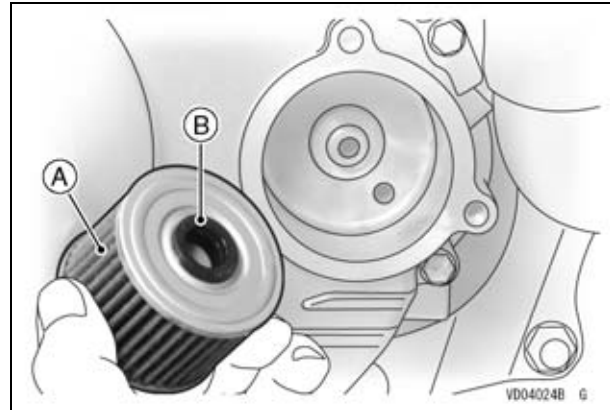

- A. Oil Filter Element
- B. Grommet

NOTICE

Inside-Out installation stop oil flow, the causing engine seizure.

- Install the oil filter cover facing the up mark to up with the grease applied to a new O-ring and tighten its bolts to the specified torque.

Oil Filter Cover Tightening Torque

8.8 N·m (0.9 kgf·m, 78 in·lb)

- After the oil has completely drained out, install the drain plug with its new gasket. Proper torque for it is shown in the table.

Engine Oil Drain Plug Tightening Torque

18 N·m (1.8 kgf·m, 13 ft·lb)

NOTE

- *Replace the damaged gasket or O-ring with a new one.*
- Fill the engine up to the upper level line with good quality engine oil specified in the table.

Recommended Engine Oil

Type: API SG, SH, SJ, SL or SM with JASO
 MA, MA1 or MA2

Viscosity: SAE 10W-40

NOTE

- *Do not add any chemical additive to the oil. Oils fulfilling the above requirements are fully formulated and provide adequate lubrication for both the engine and the clutch.*
- Install the oil filler cap/dipstick.
- Start the engine.
- Check the oil level and oil leakage.

Engine Oil Capacity

0.93 L (0.98 US qt) [When filter is not removed]
 0.95 L (1.00 US qt) [When filter is removed]
 1.1 L (1.2 US qt) [When engine is completely dry]

Although 10W-40 engine oil is the recommended oil for most conditions, the oil viscosity may need to be changed to accommodate atmospheric conditions in your riding area.

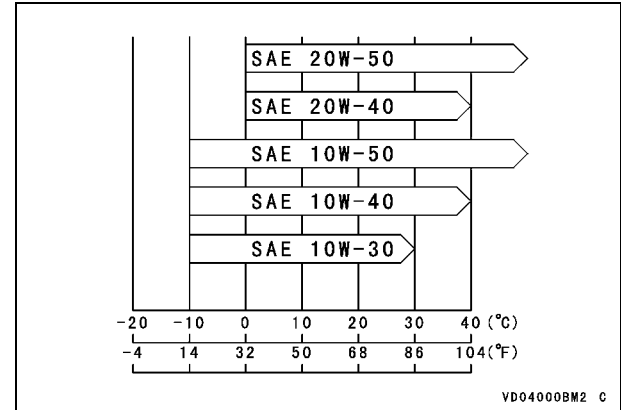

42 MAINTENANCE AND ADJUSTMENT

Spark Plug

The spark plug should be taken out periodically for inspection and regapping. Measure the gap with a wire-type thickness gauge. If incorrect, adjust the gap to the specified value by bending the outer electrode.

Spark Plug Gap

CR7HSA	0.6 ~ 0.7 mm (0.024 ~ 0.028 in.)
--------	-------------------------------------

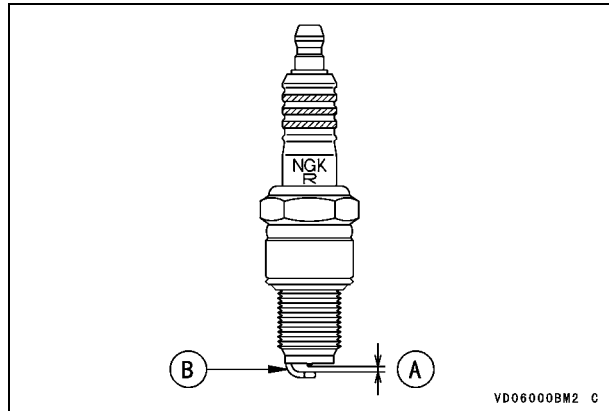

- A. Gap
- B. Outer Electrode

If the plug is oily or has carbon built up on it, clean it. The plug may also be cleaned using a high flash -point solvent and a nonmetal brush (nylon etc.). If the spark plug electrodes are corroded, or damaged, or if the insulator is cracked, replace the plug. The standard spark plug is shown in the table below.

Standard Spark Plug

NGK CR7HSA

NOTE

○ If the spark plug is replaced, use the genuine Kawasaki spark plug.

Spark Plug Removal and Installation

- Clean the cylinder head around the spark plug cap hole before removing the spark plug.
- Pull the spark plug cap off the plug before removing the spark plug.
- Apply a suitable wrench to the spark plug.
- Loosen and remove the spark plug.
- When reinstalling the spark plug, torque it to specification.

Spark Plug Tightening Torque

13 N·m (1.3 kgf·m, 9.6 ft·lb)

- Fit the plug cap securely onto the spark plug, and pull the cap lightly to make sure that it is properly installed.
- Check the spark plug lead is not damaged, or correctly routed.

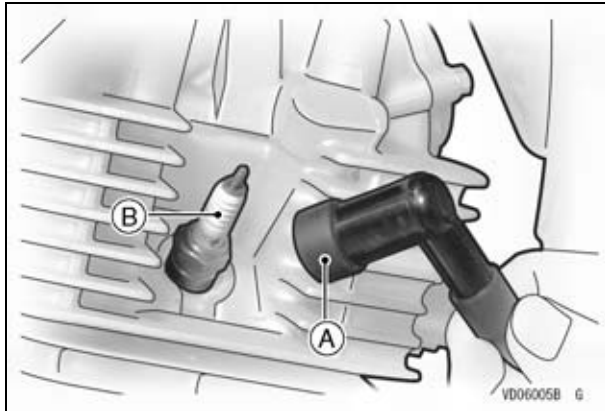

A. Plug Cap
B. Spark Plug

Air Cleaner

A clogged air cleaner restricts the air intake, increases fuel consumption, reduces engine power, and can cause spark plug fouling. Inspect the air intake system, which includes the air filter and air duct to the carburetor, and the duct clamps and carburetor, before each race or practice session.

⚠ WARNING

Dirt in the engine can cause engine damage or failure leading to an accident resulting in serious injury. Regularly inspect the air intake system for dirt or dust. If any dirt or dust is found in the system, the entire system must be cleaned to help prevent engine damage or failure.

NOTICE

A clogged air cleaner will affect fuel mixture to the engine and reduce engine power and cause spark plug fouling.

NOTE

- *In dusty areas, the element should be cleaned more frequently than recommended interval.*
- *After riding through rain or on muddy roads, the element should be cleaned immediately.*

44 MAINTENANCE AND ADJUSTMENT

Element Removal and Inspection

- Remove the screw and remove the left side cover.

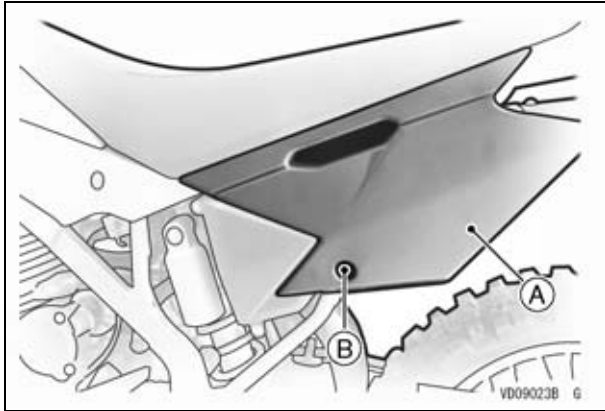

A. Left Side Cover
B. Bolt

- Remove the bolts and remove the air cleaner cover.

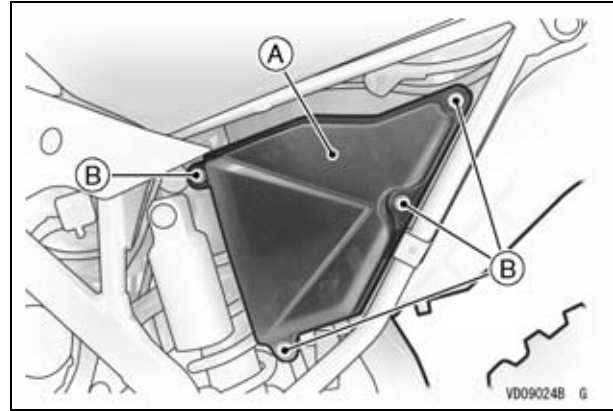

A. Air Cleaner Cover
B. Bolts

- Remove the wing bolt, and take out the air cleaner element.

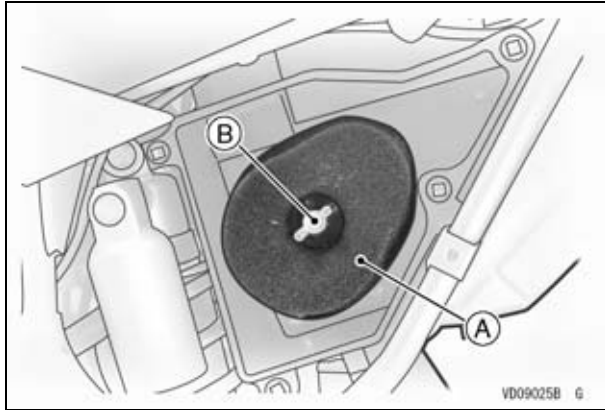

A. Air Cleaner Element
B. Wing Bolt

- Cover a clean, lint-free towel on the air cleaner housing to keep dirt from entering the carburetor.
- Wipe out the inside of the air cleaner housing with a clean, damp towel.
- Take the element off its frame.

NOTICE

Do not twist or wring the element, as it gets easily torn or damaged.

- Inspect the element. If it is dirty, clean it. Also check if the element is in good condition (no tears, hardening or shrinkage). If damaged, replace the element or it will allow dirt into the carburetor.

⚠ WARNING

A clogged air cleaner may allow dirt and dust to enter the carburetor and the throttle may stick resulting in a hazardous operating condition. Clean the air filter according to the periodic maintenance chart; more often if the vehicle is used in extremely dusty conditions.

NOTICE

A clogged air cleaner may allow dirt and dust to enter the engine, causing it to wear excessively or to become damaged.

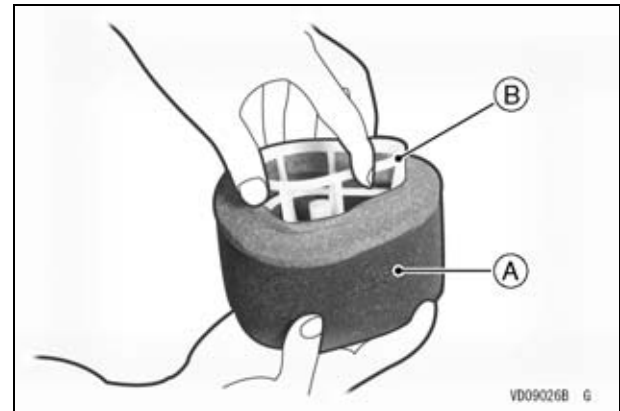

A. Air Cleaner Element
B. Element Frame

46 MAINTENANCE AND ADJUSTMENT

Element Cleaning and Installation

- Clean the element in a bath of a high flash-point solvent or hot soapy water. Rinse the element with clear water to remove all traces of the cleaning solution.
- Squeeze the element dry in a clean towel.

NOTICE

Do not twist, wring or blow the element dry to avoid damaging it.

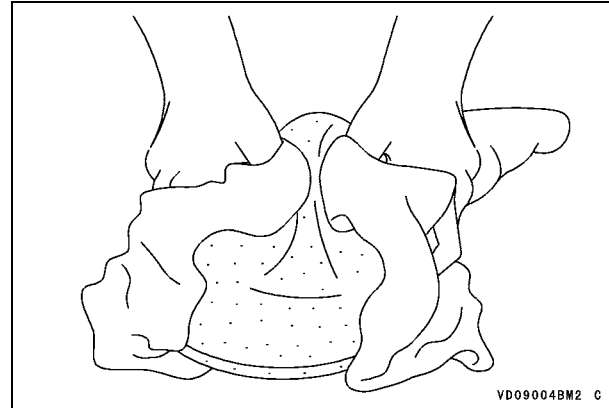
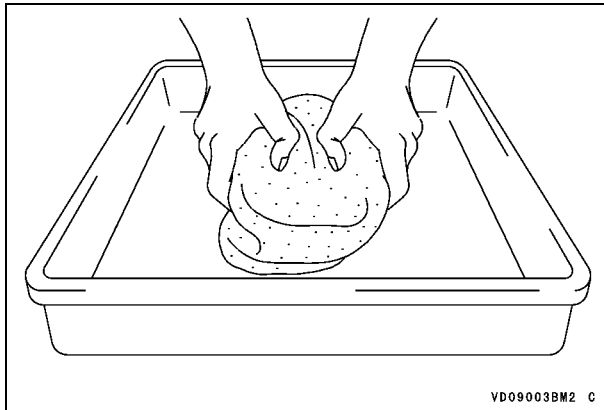

⚠ WARNING

Gasoline and low flash-point solvents can be flammable and/or explosive and cause severe burns. Clean the element in a well-ventilated area, and take care that there is no spark or flame anywhere near the working areas. Do not use gasoline or low flash-point solvents to clean the element.

- After cleaning, let the filter dry completely. Saturate the element with a high-quality foam air filter oil and make sure that the oil is evenly applied throughout the element. Squeeze out the excess oil, but do not wring the element as this could cause tearing. In this case, too much oil is better than too little. Finally pat the inside of the element with a paper towel to remove any excess oil.

- Before installation, check the element for damage such as tears, hardening, or shrinkage. If damaged, replace the element.
- Apply grease to all mating surfaces and to the screw hole in the air cleaner housing and intake tract.
- Remove the towel from the carburetor.
- Install the element onto its frame, and coat the element lip and lip seat with a thick layer of all-purpose grease to assure a complete seal.

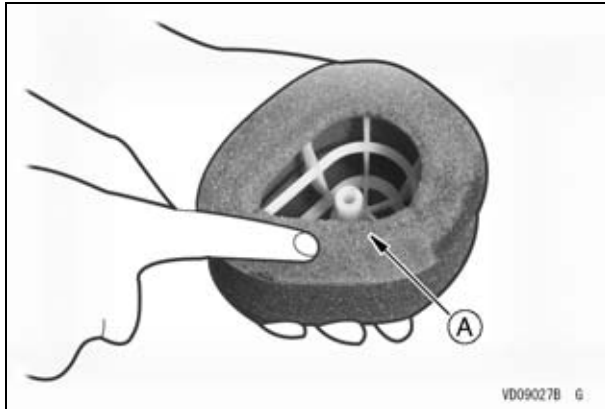

A. Apply Grease.

- Install an air cleaner element with its pointing end facing toward the rear of the motorcycle.

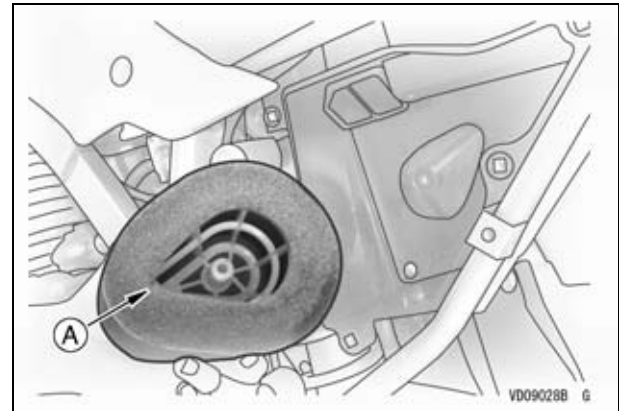

A. Pointing end

- Install the wing bolt.
- Install the air cleaner cover.
- Install the front left side cover.

48 MAINTENANCE AND ADJUSTMENT

Oil Draining

- Inspect the hose or plug to see if any oil or water has run down.

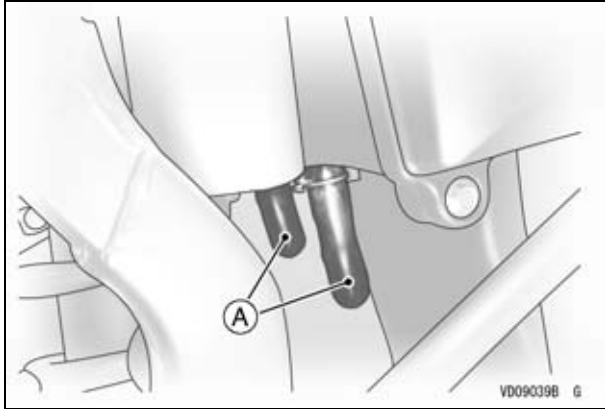

A. Oil Plugs

- If there are any oil, remove the plug and drain the oil.

⚠ WARNING

Oil on tires will make them slippery and can cause an accident and injury. Be sure to install the plug in the drain hose after draining.

Throttle Cable

Throttle Cable Adjustment

Inspect the throttle grip for smooth operation in all steering positions. Check and adjust the throttle cable in accordance with the Periodic Maintenance Chart.

- Check that the throttle grip has 2 ~ 3 mm (0.08 ~ 0.12 in.) of play and turns smoothly.

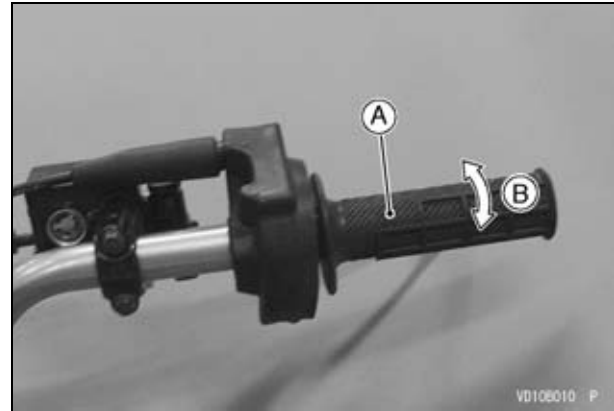

A. Throttle Grip

B. 2 ~ 3 mm (0.08 ~ 0.12 in.)

- If there is improper play, adjust it.
- Pull the rubber boot off the upper end of the throttle cable.
- Loosen the locknut on the upper end of the throttle cable and turn the adjuster to obtain the specified play.
- Then, tighten the locknut toward the adjuster.

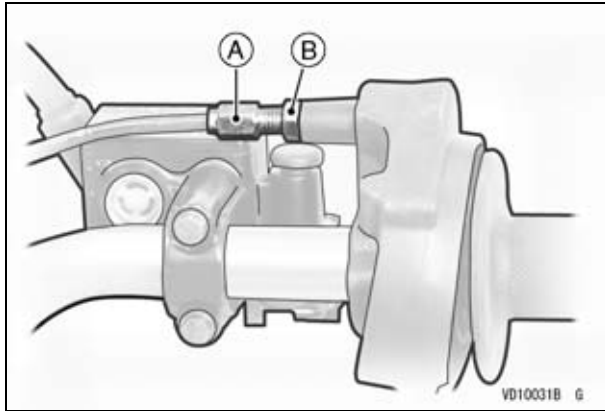

A. Adjuster
B. Locknut

- Install the rubber boot.
- If the free play cannot be set by adjusting the upper cable adjuster, use the adjuster on the lower end of the cable.
- Remove the side cover and the seat. (see Battery Removal)
- Remove the bolts and screw, and pull the right side of the fuel tank cover up temporarily.

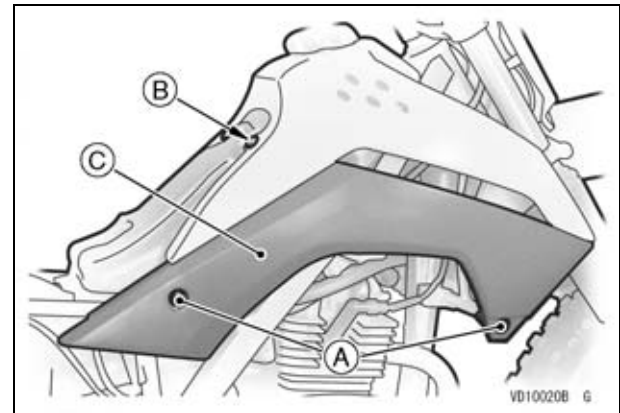

A. Bolts
B. Screw
C. Fuel Tank Side Cover

50 MAINTENANCE AND ADJUSTMENT

- Pull the rubber boot off the top of the carburetor and make the necessary free play adjustment with the adjuster on the lower end of the cable. Then, tighten the locknut and reinstall the rubber boot.

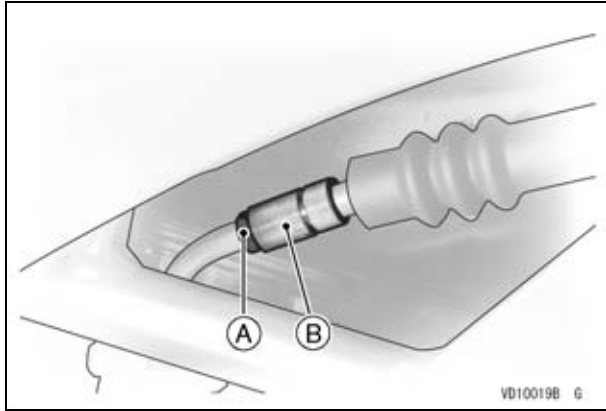

A. Locknut
B. Adjuster

- Check if the throttle grip moves smoothly from full open to close, and the throttle closes quickly and completely in all steering positions by the return spring. If not, check the throttle cable routing, grip free play, and cable damage. Then lubricate the throttle cable.
- With the engine idling, turn the handlebar both ways and check if handlebar movement changes the idling speed. If so, the throttle cable may be improperly adjusted or incorrectly routed, or damaged. Be sure to correct any of these conditions before riding.
- Reinstall the parts removed.

⚠ WARNING

Operation with an improperly adjusted, incorrectly routed, or damaged cables could result in an unsafe riding condition. Be sure the control cables are adjusted and routed correctly, and are free from damage.

Choke Knob

Choke Knob Adjustment

- Take out the number plate by removing the bolt.

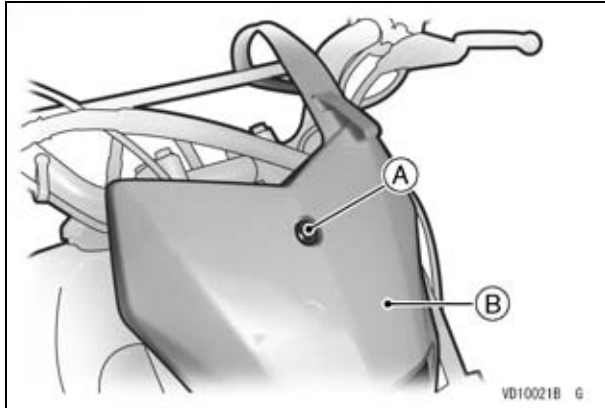

A. Bolt

B. Number Plate

- Pull the choke knob fully up and set it where the knob stops.

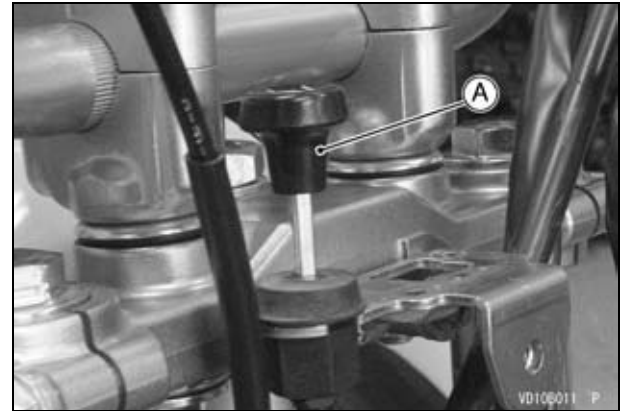

A. Choke Knob

52 MAINTENANCE AND ADJUSTMENT

- Pull the rubber boot off the adjuster, and adjust with the adjuster so that the knob can be pushed back with a finger.

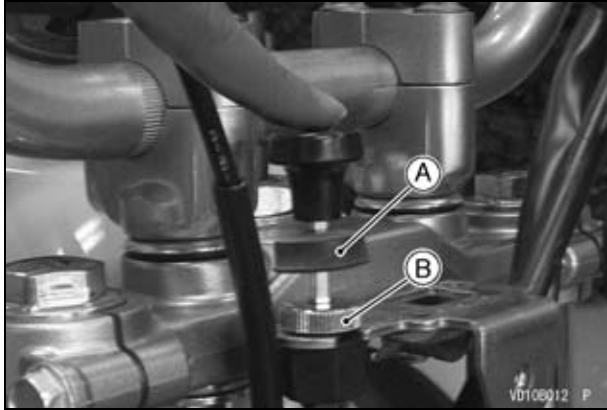

- A. Rubber Boot
- B. Adjuster

NOTE

- *If you over-tighten the adjuster, it will become hard to push back.*
- Reinstall the parts removed.

Idle Speed

The following procedure covers the idling adjustment, which should be performed whenever the idle speed is disturbed.

Idling Adjustment

- Thoroughly warm up the engine.

⚠ DANGER

Exhaust gas contains carbon monoxide, a colorless, odorless poisonous gas. Inhaling carbon monoxide can cause serious brain injury or death. **DO NOT** run the engine in enclosed areas. Operate only in a well-ventilated area.

⚠ WARNING

The engine and exhaust system get extremely hot during normal operation and can cause serious burns. **Never touch a hot engine or an exhaust pipe during idle speed adjustment.**

- Adjust the idling speed 1 350 ~ 1 450 r/min (rpm) by turning the idling adjusting screw.

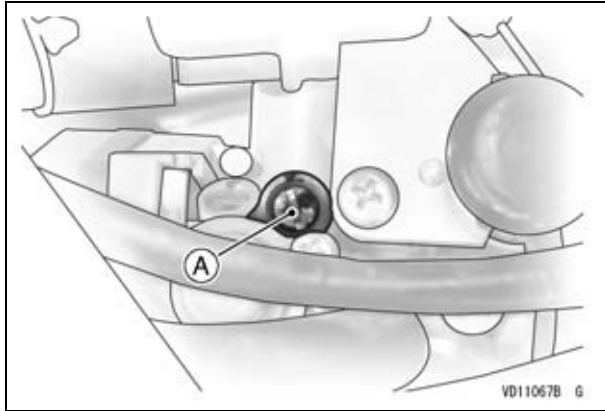

A. Idling Adjusting Screw

- Open and close the throttle a few times to make sure the idling speed does not change, and readjust if necessary.
- With the engine idling, turn the handlebar both ways and check if handlebar movement changes the idling speed. If so, the throttle cable may be improperly adjusted, incorrectly routed, or damaged. Be sure to correct any of these conditions before riding.

⚠ WARNING

Operation with a damaged cable could result in an unsafe riding condition. Replace a damaged control cable before operation.

Clutch

Clutch Lever Adjustment

Proper clutch lever play is 2 ~ 3 mm (0.08 ~ 0.12 in.). Lever play increases with cable stretch and friction plate wear, requiring periodic adjustment.

When the clutch lever play is out of specification, first try adjusting it at the clutch lever as follows.

- Slide the clutch lever dust cover back.
- Loosen the locknut, turn the adjuster to obtain the proper amount of clutch lever play, then tighten the locknut.

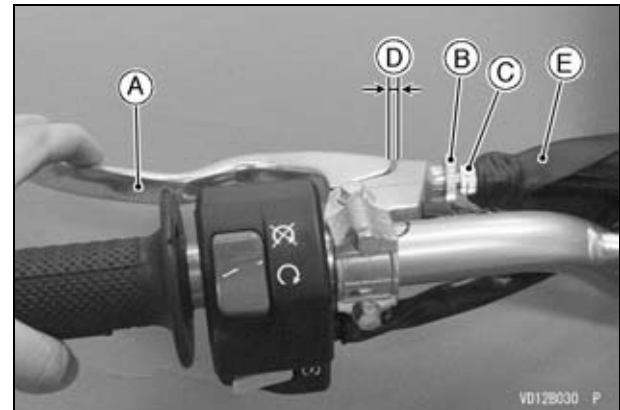

- A. Clutch Lever
- B. Locknut
- C. Adjuster
- D. 2 ~ 3 mm (0.08 ~ 0.12 in.)
- E. Dust Cover

54 MAINTENANCE AND ADJUSTMENT

If the clutch lever play cannot be adjusted at the clutch lever, make the adjustment further down the cable as follows.

- Loosen the locknut at the clutch lever.
- Turn the adjuster in all the way, then tighten the locknut.
- Loosen the locknut at the lower end of the clutch cable, and turn the adjusting nut so that the clutch lever play is 2 ~ 3 mm (0.08 ~ 0.12 in.).

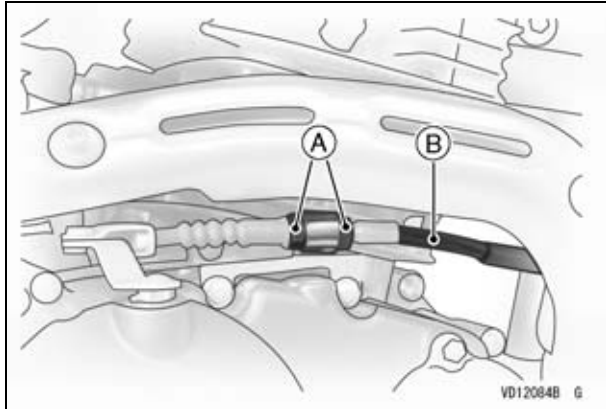

A. Locknuts
B. Clutch Cable

- Tighten the locknut.
- Start the engine, check that the clutch does not slip and it releases properly.
- Slide the dust cover back into place.

⚠ WARNING

Too much cable play can prevent clutch disengagement and cause an accident resulting in serious injury or death. When adjusting the clutch or replacing the cable, be sure the upper end of the clutch outer cable is fully seated in its fitting, or it could slip into place later, creating enough cable play to prevent clutch disengagement.

Valve Clearance

Valve and valve seat wear decreases valve clearance, upsetting valve timing.

NOTICE

<p>If valve clearance is left unadjusted, wear will eventually cause the valves to remain partly open, which lowers performances, burns the valves and valve seats, and may cause serious engine damage.</p>

Valve clearance for each valve should be checked and adjusted in accordance with the Periodic Maintenance Chart. Inspection and adjustment should be done only by an authorized Kawasaki dealer.

NOTE

- *If the engine is hot, wait until the engine cools. Valve clearance must be checked when the engine is cold (room temperature).*

Spark Arrester

This vehicle is equipped with a spark arrester. It must be properly maintained to ensure its efficiency. In accordance with the Periodic Maintenance Chart, clean the spark arrester.

NOTICE

<p>The spark arrester must be installed correctly and functioning properly to provide adequate fire protection.</p>
--

Spark Arrester Cleaning

 WARNING
--

<p>Hot exhaust system parts can cause serious burns. The exhaust system becomes very hot soon after the engine is started. To avoid burns, be sure the exhaust system is cold before cleaning the spark arrester.</p>
--

56 MAINTENANCE AND ADJUSTMENT

- Remove the muffler end mounting bolts.

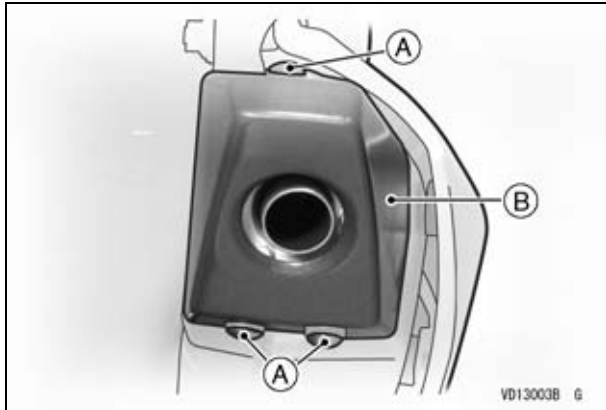

A. Muffler End Mounting Bolts
B. Muffler End

- Take off the spark arrester mounting bolts.

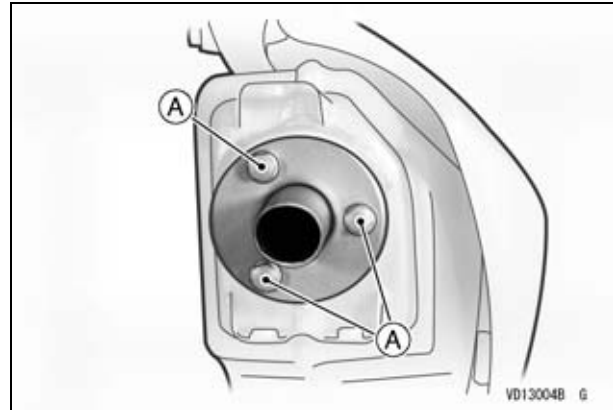

A. Spark Arrester Mounting Bolts

- Remove the spark arrester.

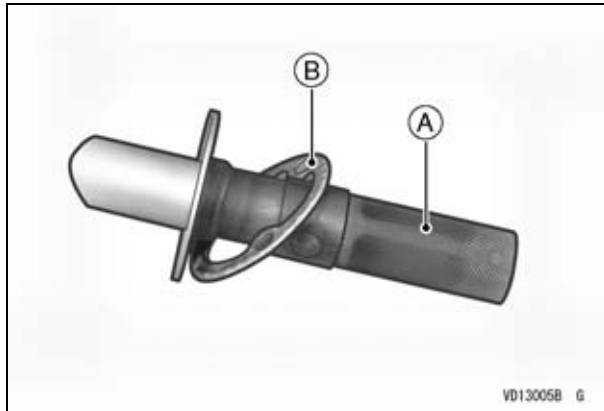

- A. Spark Arrester**
- B. Gasket**

- With a wire brush, remove the carbon off the inside of the spark arrester and muffler.
- Replace the gasket to the new one.
- Install the spark arrester into the rear end of the muffler.
- Install the muffler end.

Drive Chain

For safety and to prevent excessive wear, the drive chain must be checked, adjusted, and lubricated before riding. If the chain becomes badly worn or mal-adjusted - either too loose or too tight - it could jump off the sprockets or break.

⚠ WARNING

A chain that breaks or jumps off the sprockets could snag on the engine sprocket or lock the rear wheel, severely damaging the motorcycle and causing it to go out of control. Inspect the chain for damage and proper adjustment before each ride.

58 MAINTENANCE AND ADJUSTMENT

Chain Slack Inspection

- Raise the rear wheel off the ground, then rotate the rear wheel to find the place where the chain is tightest (because it wears unevenly).
- Push up the drive chain in the middle of the upper chain run to measure the chain slack. The distance between the chain and the swingarm (at the end of the chain slipper) should be within the standard value.

Drive Chain Slack

Standard	35 ~ 41 mm (1.4 ~ 1.6 in.)
----------	----------------------------

- Adjust the drive chain if its slack is out of specification.

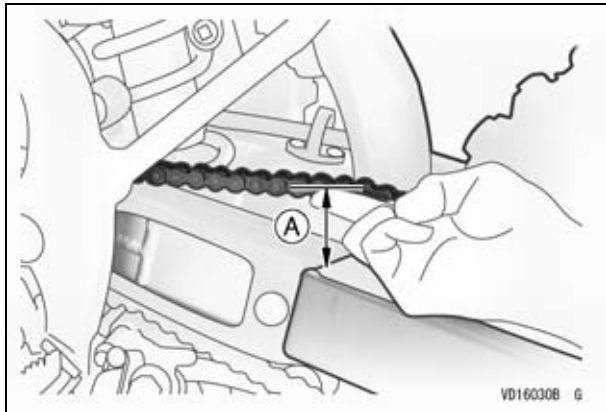

A. Chain Slack

- In addition to checking the slack, rotate the rear wheel to inspect the drive chain for damaged rollers, loose pins and links and the sprockets for unevenly or excessively worn and damaged teeth.
- If there are any such defects, replace the drive chain and/or the sprockets.

Chain Slack Adjustment

- Remove the cotter pin from the rear axle nut.
- Loosen the rear axle nut and both chain adjuster locknuts.
- Turn both chain adjusting bolts evenly until the drive chain slack (measured between the chain and the swingarm) is within the standard value. For the rear wheel to be properly aligned, the chain adjuster end of the left chain adjuster should align with the same swingarm mark that the chain adjuster end of the right chain adjuster aligns with.

Drive Chain Slack

35 ~ 41 mm (1.4 ~ 1.6 in.)

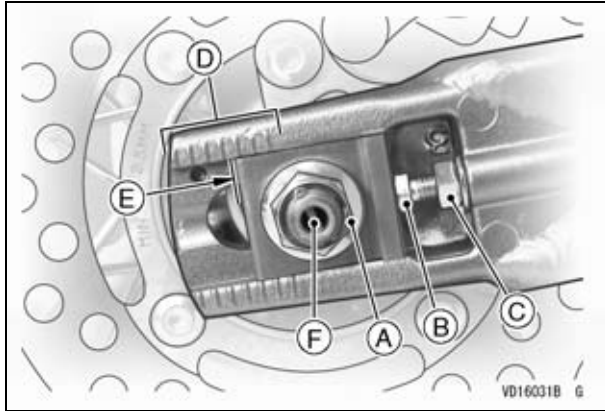

- A. Axle Nut
- B. Adjusting Bolt
- C. Locknut
- D. Marks
- E. Chain Adjuster End
- F. Cotter pin

NOTE

- *Wheel alignment can also be checked using the straightedge or string method.*

⚠ WARNING

Misalignment of the wheel will result in abnormal wear, and may result in an unsafe riding condition. Align the rear wheel using the marks on the swingarm or measuring the distance between the center of the axle and swingarm pivot.

- Tighten both chain adjuster locknuts.
- Torque the axle nut to the specified torque.

Rear Axle Nut Tightening Torque

79 N·m (8.1 kgf·m, 58 ft·lb)

- Rotate the wheel, measure the chain slack again at the tightest position, and readjust it if necessary.
- Install a new cotter pin through the axle, and spread its ends.

⚠ WARNING

A loose axle nut can lead to an accident resulting in serious injury or death. Tighten the axle nut to the proper torque and install a new cotter pin.

- Check the rear brake effect.

Chain Wear Inspection

When the chain has reached its wear limit (i.e., when it has stretched by 1.7% of its original length), it is no longer safe for use and should be replaced. Since it is impractical to measure the entire length of the chain, determine the degree of wear by measuring a 20-link section of the chain.

- Tighten the chain either by using the chain adjusters or by hanging a 10 kg (22 lb) weight on the chain.

60 MAINTENANCE AND ADJUSTMENT

- Measure the 20-link section on a straight part of the chain from the center of the 1st pin to the center of the 21st pin. If the length exceeds the service limit, the chain should be replaced. Since worn sprockets will cause a new chain to wear faster, inspect both the engine and rear sprockets whenever the chain is replaced, and replace them if necessary.

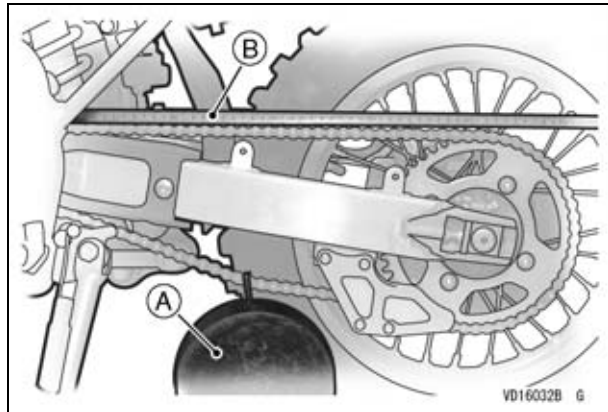

- A. Weight
- B. Tape Measure

Drive Chain 20-Link Section

Standard length	254.0 ~ 254.6 mm (10.00 ~ 10.02 in.)
Wear limit	259 mm (10.2 in.)

NOTE

- The drive chain without a master link clip is installed at the factory.
- The drive system was designed for use with a DAIDO D.I.D 428H (KLX140A: 122-link, KLX140B: 126-link) chain. For maximum stretch resistance and safety, a genuine part must be used for replacement.
- To minimize any chance of the Master Link coming apart, the master link clip must be installed with the closed end of the "U" pointing in the direction of chain rotation.

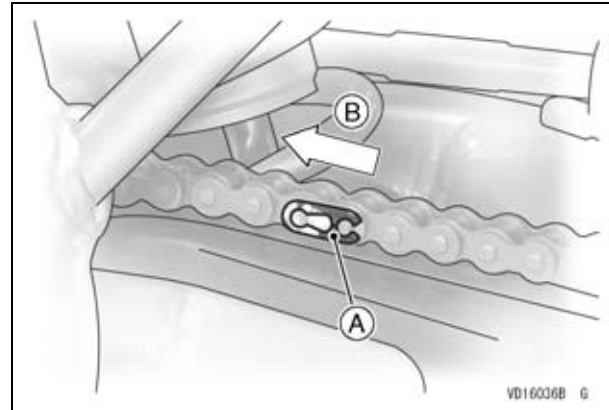

- A. Master Link Clip
- B. Direction of Rotation

Chain Guide Wear Inspection

- Visually inspect the drive chain guide and replace it if excessively worn or damaged.

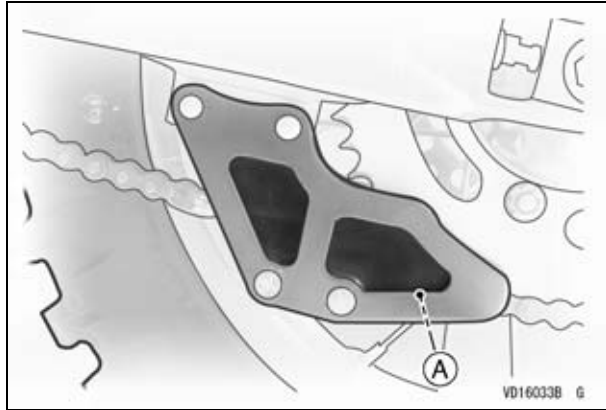

A. Chain Guide

Chain Slipper Wear Inspection

- Visually inspect the front end of the chain slippers on the swingarm and replace them if worn or damaged.

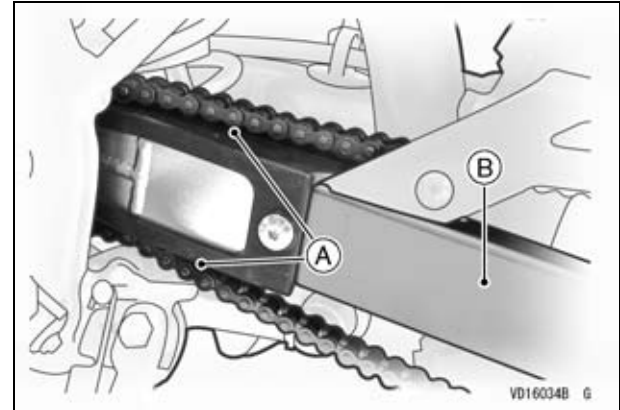

A. Chain Slippers
B. Swingarm

62 MAINTENANCE AND ADJUSTMENT

Sprocket Wear Inspection

- Visually inspect the sprocket teeth and replace the sprocket if its teeth are worn or damaged.

Sprocket Tooth Wear

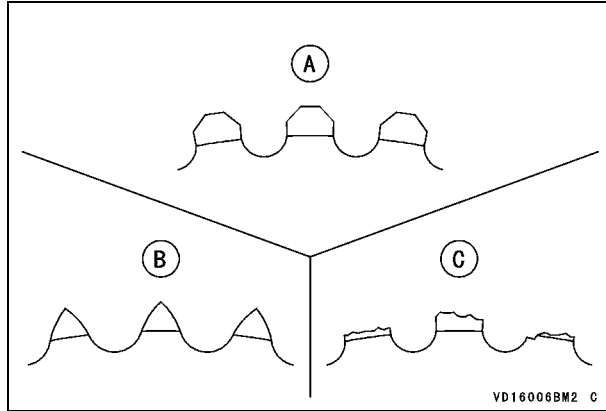

- A. Good Teeth
- B. Worn Teeth
- C. Damaged Teeth

NOTE

- Sprocket wear is exaggerated in the illustration.

Chain Lubrication

Lubrication is necessary after riding through rain or on wet roads, or any time that the chain appears dry.

Use a chain lubricant for motorcycle. If the chain is especially dirty, clean it using a cleaner following the instructions supplied by the chain cleaner manufacturer.

- Apply lubricant to the sides of the rollers so that it will penetrate to the rollers and bushings. Wipe off any excess lubricant.

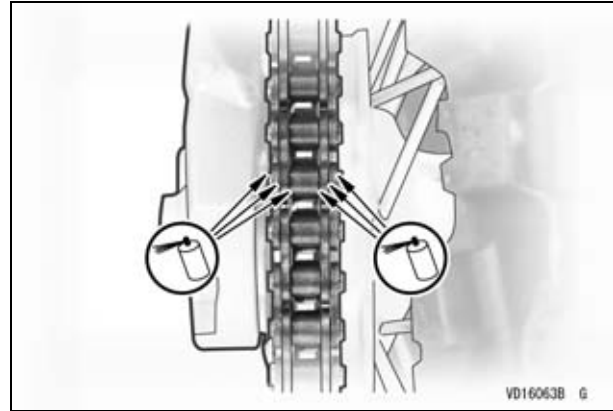

- Wipe off any lubricant that gets on the tire surface.

Handlebar

To suit various riding positions, the handlebar can be adjusted by turning the handlebar holders around.

- Remove the handlebar clamp bolts, the clamps and the handlebar.
- Check the handlebar for bent or crack.

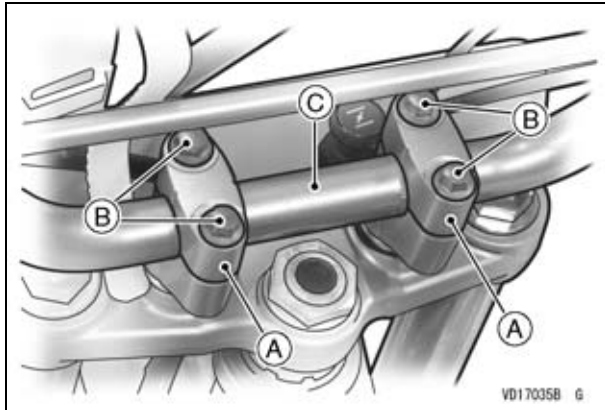

- A. Handlebar Clamps**
- B. Bolts**
- C. Handlebar**

- Loosen the handlebar holder nuts, turn the handlebar holders 180°, and securely tighten the nuts.

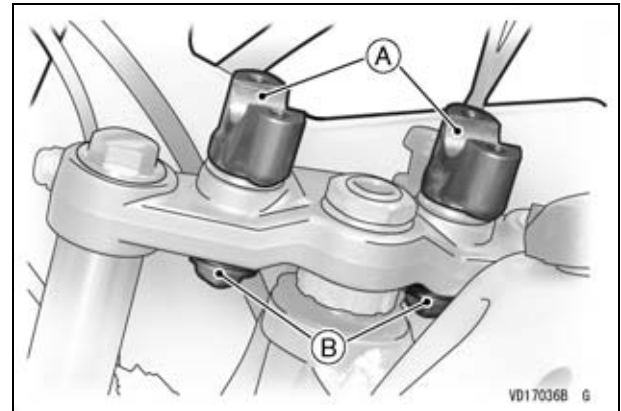

- A. Handlebar Holders**
- B. Handlebar Holder Nuts**

64 MAINTENANCE AND ADJUSTMENT

- Put the handlebar on the handlebar holders.
- Mount the handlebar clamps.
- Align the gap at the rear with the punch mark on the handlebar.

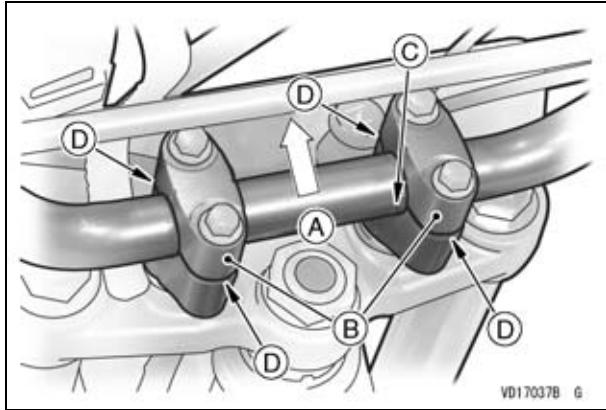

- A. Front
- B. Handlebar Clamps
- C. Punch Mark
- D. Gap

- Tighten the front and rear bolts of the handlebar clamps equally. If the handlebar clamps are correctly installed, there will be even gap on the front and rear side of the clamp after the bolts torqued.

Handlebar Clamp Bolts Tightening Torque

25 N·m (2.5 kgf·m, 18 ft·lb)

NOTE

- Tighten the two clamp bolts alternately two times to ensure even tightening torque.
- Check the front brake for the proper brake effect, or no brake drag.

Brakes

Disc and disc pad wear is automatically compensated for and has no effect on the brake lever or pedal action. There are no parts on the brakes that require adjustment except brake lever position.

Brake Lever Position

The brake lever position can be adjusted to suit the rider's preference.

- To adjust the brake lever position, loosen the locknut, and turn the adjuster to either side.
- After adjustment, tighten the locknut securely.

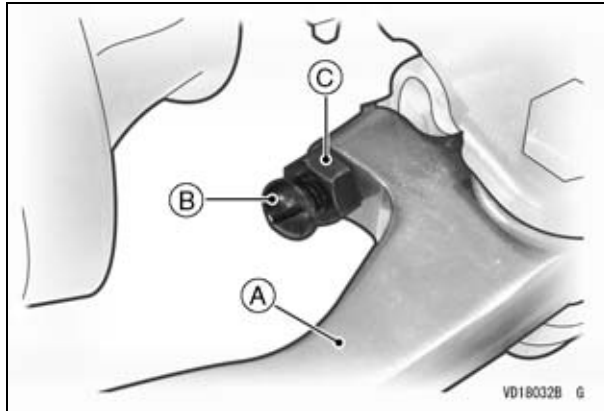

- A. Brake Lever
- B. Adjuster
- C. Locknut

- Test the braking power and check that there is no brake drag.

⚠ WARNING

Air in the brake lines diminish braking performance and can cause an accident resulting in injury or death. If the brake lever or pedal feels mushy when it is applied, there might be air in the brake lines or the brake may be defective. Have the brake checked immediately by an authorized Kawasaki dealer.

Disc Brake Fluid

Inspect the brake fluid level in the front and rear reservoirs and change the brake fluid in accordance with the Periodic Maintenance Chart. The brake fluid should also be changed when contaminated with dirt or water.

Use only heavy-duty brake fluid as follows.

Front/Rear Brake Fluid : DOT 3 or DOT 4

NOTE

- *The motorcycle is shipped with brake fluid DOT4 in the brake system.*

66 MAINTENANCE AND ADJUSTMENT

NOTICE

Do not spill brake fluid onto any painted surface.

Do not use fluid from a container that has been left open or that has been unsealed for a long time.

Check for fluid leakage around the brake system fittings.

Check for brake hose damage.

Brake Fluid Level Inspection (Front and Rear Reservoirs)

With the front or rear reservoir positioned horizontally, the brake fluid must always be above the minimum level line.

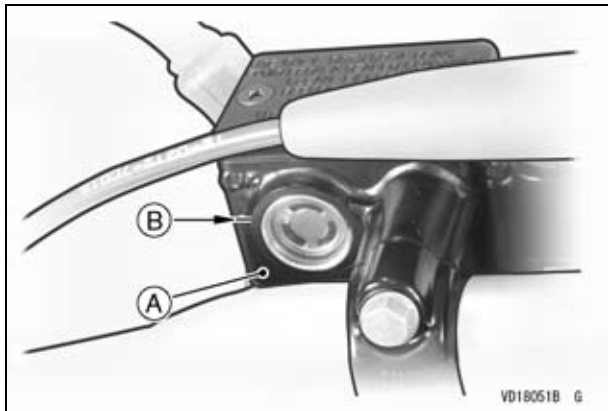

A. Front Reservoir
B. Minimum Level Line

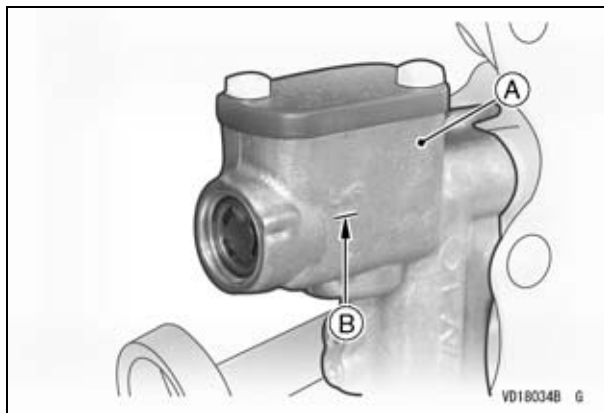

A. Rear Reservoir
B. Minimum Level Line

- If the brake fluid in the front or rear reservoir is below the minimum level line, check for fluid leaks in the brake line and fill the reservoir to the maximum level line. (The step inside the front and rear reservoirs indicate the maximum level.)

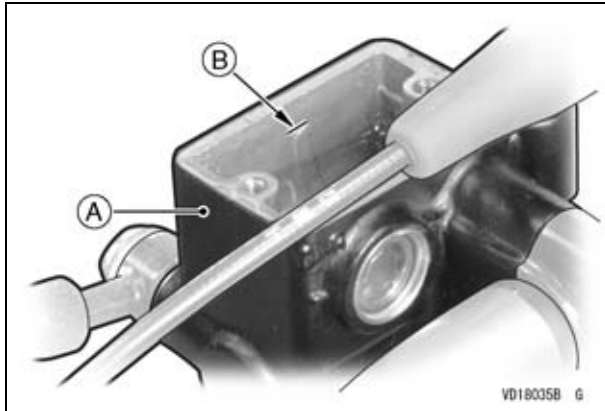

A. Front Reservoir
B. Maximum Level Line

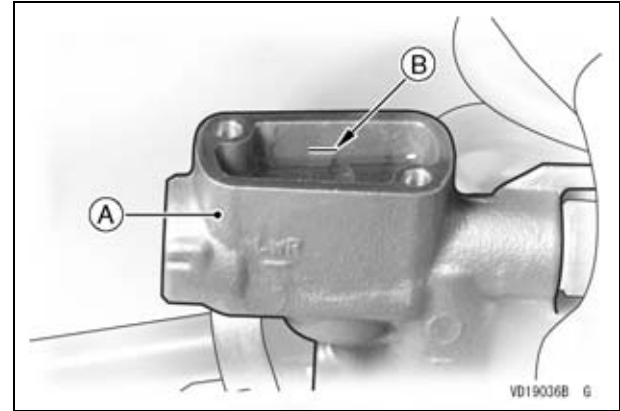

A. Rear Reservoir
B. Maximum Level Line

⚠ WARNING

Mixing brands and types of brake fluid can reduce the brake system's effectiveness and cause an accident resulting in injury or death. Do not mix two brands of brake fluid. Change the brake fluid in the brake line completely if the brake fluid must be refilled but the type and brand of the brake fluid that is already in the reservoir are unidentified.

68 MAINTENANCE AND ADJUSTMENT

Brake Pad Wear Inspection

Inspect the brake pads for wear in accordance with the Periodic Maintenance chart. If the thickness of any pad in any (front or rear) brake caliper is less than 1 mm (0.04 in.), have both pads in the caliper replaced as a set. Pad replacement should be done by an authorized Kawasaki dealer.

Usable Brake Pad Range

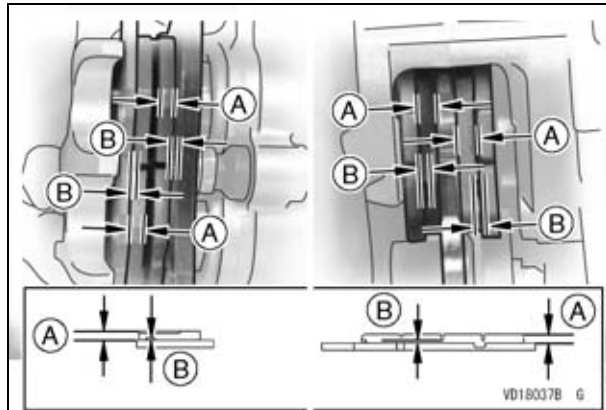

- A. Lining Thickness**
- B. 1 mm (0.04 in.)**

Steering

The steering should always be kept adjusted so that the handlebar will turn freely but not have excessive play.

Steering Inspection

- To check the steering adjustment, raise the front wheel off the ground using a jack (special tool).
- Push the handlebar lightly to either side. If the handlebar continues moving under its own momentum, the steering is not too tight.
- Squatting in front of the motorcycle, grasp the lower ends of the front fork at the axle, and push and rock the front fork back and forth as shown. If play is felt, the steering is too loose and needs to be adjusted.

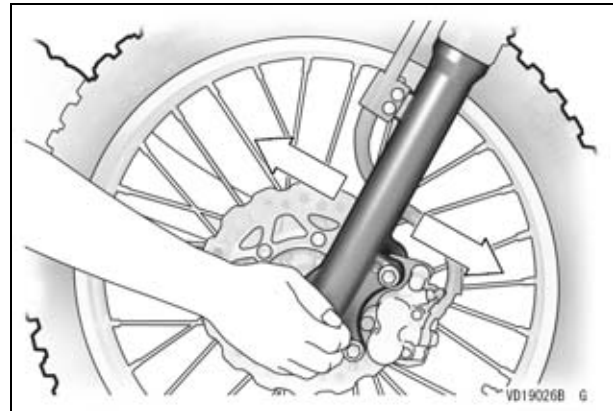

Steering Adjustment

- Raise the front wheel off the ground using a jack (special tool).
- Remove the handlebar.
- Loosen the left and right front fork upper clamp bolts.
- Remove the steering stem head nut, and raise the front fork upper clamp.

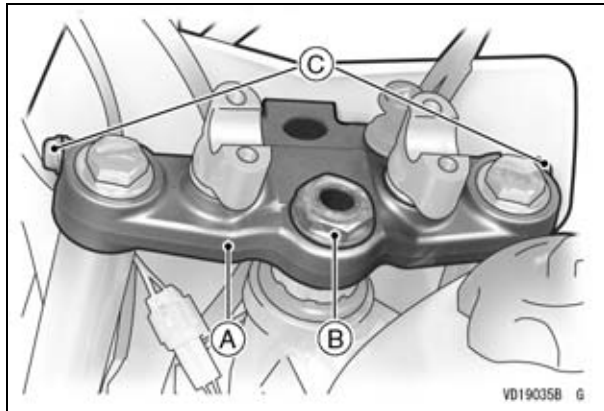

- A. Front Fork Upper Clamp**
- B. Steering Stem Head Nut**
- C. Front Fork Upper Clamp Bolts**

- Turn the steering stem locknut with a stem nut wrench (special tool) to obtain the proper adjustment.

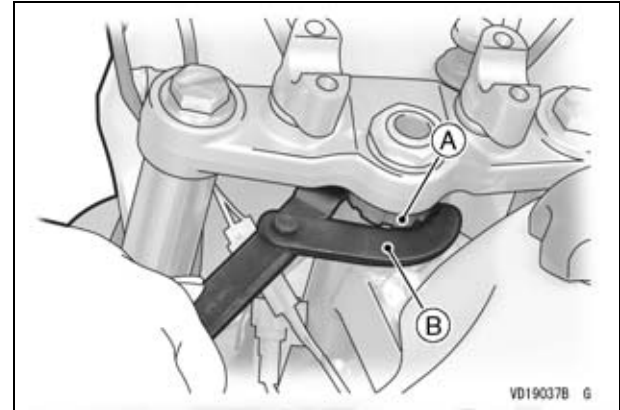

- A. Steering Stem Locknut**
- B. Stem Nut Wrench (P.N. 57001-1100)**

- Install the front fork upper clamp to the original position.
- Apply the specified torques to the steering head nut and front fork upper clamp bolts.

Steering Stem Head Nut Tightening Torque

64 N·m (6.5 kgf·m, 47 ft·lb)

Front Fork Upper Clamp Bolt Tightening Torque

20 N·m (2.0 kgf·m, 15 ft·lb)

- Install the handlebar.

70 MAINTENANCE AND ADJUSTMENT

NOTE

- *Tighten the two clamp bolts alternately two times to ensure even tightening torque.*
- Install the handlebar and apply the specified torque, check the steering again and readjust it if necessary.

Handlebar Clamp Bolts Tightening Torque

25 N·m (2.5 kgf·m, 18 ft·lb)

NOTE

- *Tighten the two clamp bolts alternately two times to ensure even tightening torque.*
- Check the front brake for the proper brake effect, or no brake drag.

Front Suspension

Front Fork Inspection

NOTICE

Sticking muds or dusts on the sliding surface of the front fork could damage to the oil seal, leading to an oil leak. Clean the sliding surface after each ride.

- Holding the brake lever, pump the front fork back and forth manually to check for smooth operation.
- Visually inspect the front fork for oil leakage, scoring or scratches on the outer surface of the inner tube.
- If necessary, repair or replace by an authorized Kawasaki dealer.

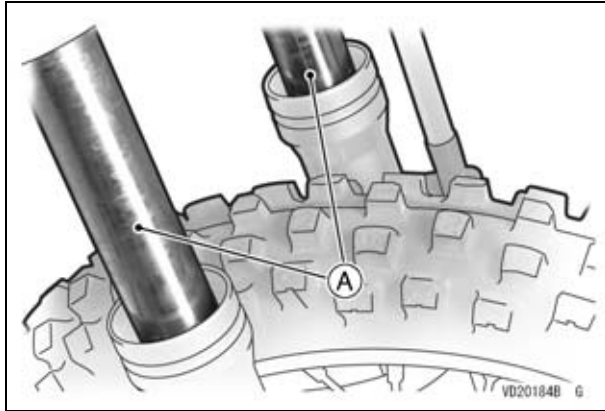

A. Inner Tube

NOTICE

If the inner tube is badly bent or creased, replace it. Excessive bending, followed by subsequent straitening, can weaken the inner tube.

Rear Suspension

Rear Shock Absorber Inspection

NOTICE

Sticking muds or dusts on the sliding surface of the rear shock absorber could damage to the oil seal, leading to an oil leak. Clean the sliding surface after each ride.

- Pump the seat down and up by 4 or 5 times, and inspect the smooth stroke.
- If it does not smoothly or noise is found, inspect the oil leak and rear shock absorber mounting.
- Visually inspect the rear shock absorber for oil leakage.
- If necessary, repair or replace by an authorized Kawasaki dealer.

Rear Shock Absorber Adjustment

The spring preload of the shock absorber can be adjusted or the spring can be replaced with an optional one to suit various riding conditions. In addition, the damping force can be adjusted easily, making it unnecessary to change the oil viscosity.

72 MAINTENANCE AND ADJUSTMENT

Rebound Damping Adjustment (KLX140B ONLY)

To adjust the rear shock absorber rebound damping, turn the rebound damping adjuster at the bottom of the rear shock absorber with a standard tip screwdriver.

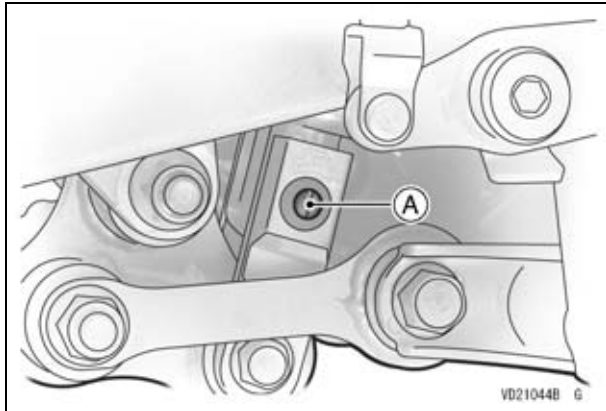

A. Rebound Damping Adjuster

If the damping feels too soft or too stiff, adjust it in accordance with the following table.

Rebound Damping Adjuster Settings

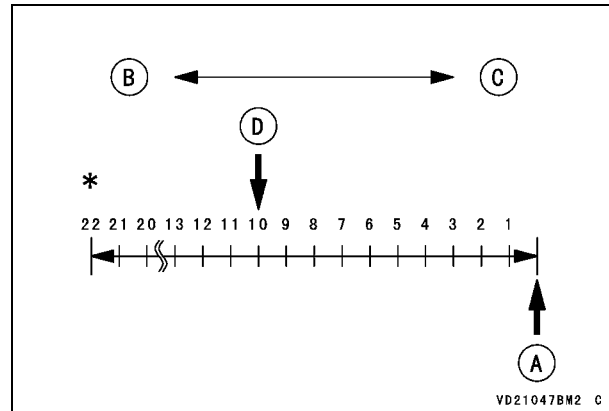

- A. Seated Position (Adjuster Turned Fully Clockwise)
- B. Softer (Counterclockwise)
- C. Harder (Clockwise)
- D. Standard Setting

* Number of turns counterclockwise usable range-22 clicks or more

Standard Rebound Damping Adjuster Setting

10 th clicks*

* Counterclockwise from the fully seated position

NOTICE

Do not force the rebound and compression damping force adjusters beyond the fully seated position, or the adjusting mechanism may be damaged.

Compression Damping Adjustment (KLX140B ONLY)

To adjust the rear shock absorber compression damping, turn the compression damping adjuster on the gas reservoir with a standard tip screwdriver.

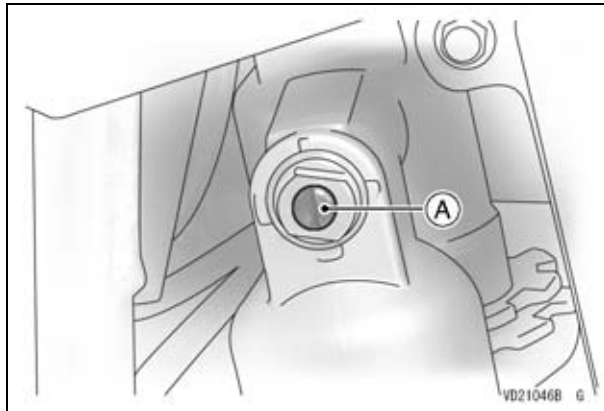

A. Compression Damping Adjuster

If the damping feels too soft or too stiff, adjust it in accordance with the following.

Compression Damping Adjuster Setting

The compression damping adjuster is a 4-stage adjustable.

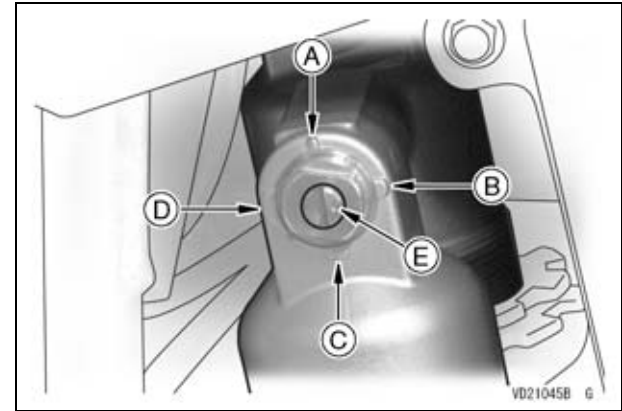

- A. 1st (Softest)
- B. 2nd
- C. 3rd
- D. 4th (Hardest)
- E. Adjusting Mark

Standard Compression Damping Adjuster Setting

2nd position

74 MAINTENANCE AND ADJUSTMENT

Spring Preload Adjustment

The rear shock absorber can be adjusted by changing the spring preload for various riding and loading conditions. If the spring action feels too soft or too stiff, have it adjusted by an authorized Kawasaki dealer.

NOTE

- *The installation and removal of the rear shock absorber should be done by an authorized Kawasaki dealer.*

Wheels

Tire Air Pressure

Tire air pressure affects traction, handling, and tire life. Adjust the tire air pressure to suit track conditions and rider preference, but keep it close within the recommended range.

- To check the tire air pressure, remove the air valve cap, and make sure to tighten the cap securely after checking the tire pressure.
- Reduce the tire air pressure to increase the tire tread surface on the ground when riding on a wet, muddy, sandy or slippery track.
- Increase the tire air pressure to prevent damage or punctures (though the tires will skid more easily) when riding on a pebbly or hard track.

Tire Air Pressure Adjustable Range

80 kPa (0.8 kgf/cm ² , 11 psi) ~ 100 kPa (1.0 kgf/cm ² , 14 psi)

NOTE

- *Tire air pressure should be checked when the tires are cold, before you ride the motorcycle.*

Spokes and Rims

The spokes on both wheels must all be securely and evenly tightened and not be allowed to loosen. Unevenly tightened or loose spokes will cause the rim to warp, the nipples and spokes to fatigue more quickly, and the spokes to break.

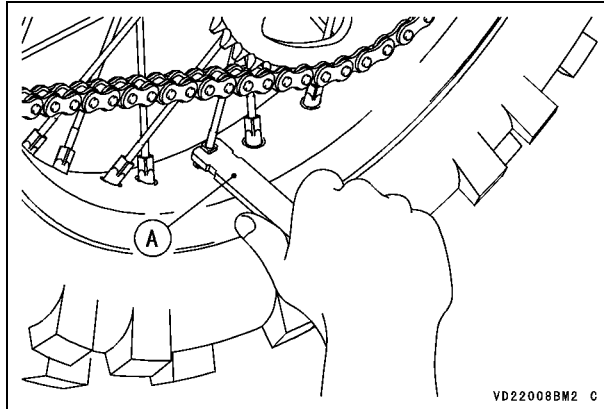

A. Spoke and Spark Plug Wrench

VD22008BM2 C

Bead Protector

There is a bead protector on the both wheels. The bead protector prevents the tire and tube from slipping on the rim and damaging the valve stem. Valve stem damage may cause the tube to leak, necessitating tube replacement. In order to keep the tire and tube in position on the rim, inspect the bead protector before riding and tighten it if necessary. Tighten the valve stem nut finger tight only.

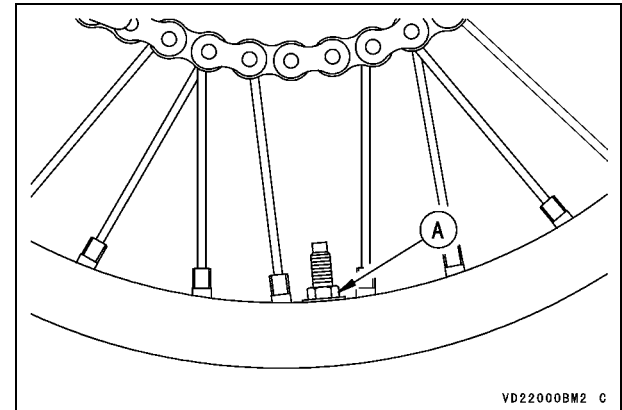

A. Bead Protector

VD22008BM2 C

76 MAINTENANCE AND ADJUSTMENT

Rim Runout

Set up a dial gauge on the side of the rim and rotate the wheel to measure its axial runout. The difference between the highest and lowest readings is the amount of runout.

- Set up the dial gauge on the inner circumference of the rim and rotate the wheel to measure its radial runout. The difference between the highest and lowest readings is the amount of runout.
- A certain amount of rim warpage (runout) can be corrected by recentering the rim, that is, by loosening some spokes and tightening other to change the position of certain portions of the rim. If the rim is badly bent, however, it should be replaced.

NOTE

- *The welding spot of the rim may show excessive runout. Disregard this when measuring rim runout.*

Rim Runout

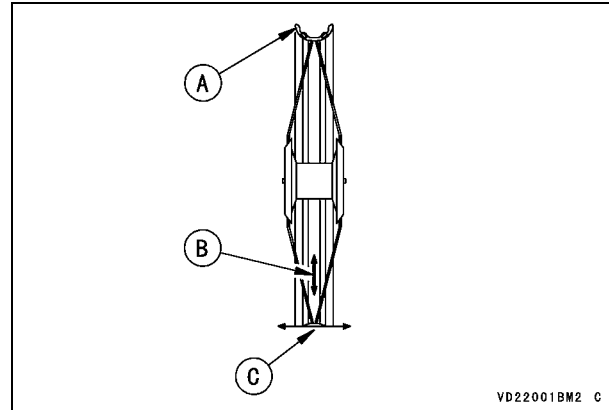

- A. Rim
- B. Radial Runout
- C. Axial Runout

Rim Runout Maximum Limit

Axial	2.0 mm (0.08 in.)
Radial	

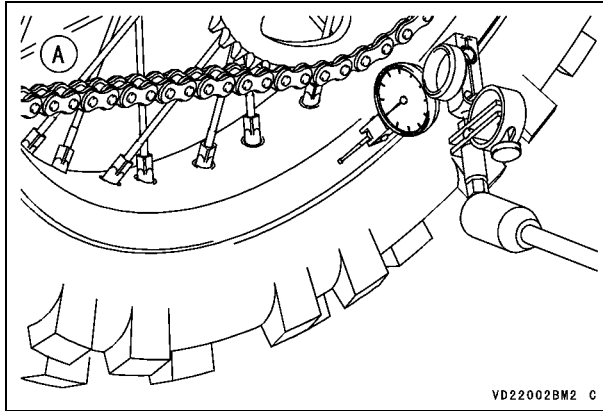

A. Axial Rim Runout Measurement

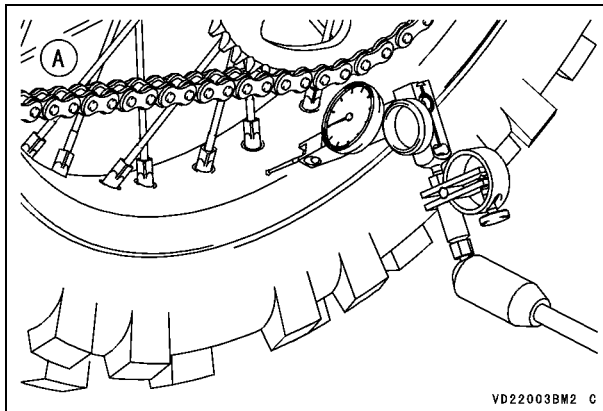

A. Radial Rim Runout Measurement

Hoses Inspection

Check the brake and fuel hoses for cracks or deterioration, and the connections for looseness in accordance with the Periodic Maintenance Chart.

- Inspect the brake hose and fittings for deterioration, cracks and signs of leakage by bending or twisting the hoses.
- If damaged, replace the hoses.

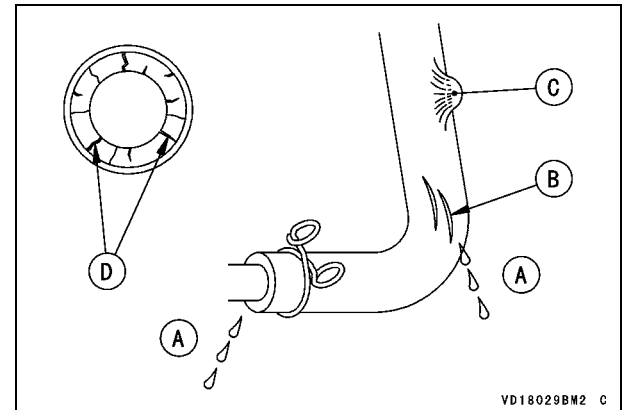

- A. Leakage**
- B. Cracks**
- C. Bulges**
- D. Ozone Cracks**

- Check the hose are securely connected and clamps are tightened correctly.

78 MAINTENANCE AND ADJUSTMENT

Battery

The battery installed in this motorcycle is a sealed type, so it is not necessary to check the battery electrolyte level or add distilled water.

However, in order to maximize battery life and ensure that it will provide the power needed to start the motorcycle you must properly maintain the battery's charge. When used regularly, the charging system in the motorcycle helps keep the battery fully charged. If your motorcycle is only used occasionally or for short periods of time, the battery is more likely to discharge.

Due to their internal composition, batteries continually self discharge. The discharge rate depends on the type of battery and ambient temperature. As temperatures rise, so does the discharge rate. Every 15°C (59°F) doubles the rate.

Electrical accessories, such as digital clocks and computer memory, also draw current from the battery even when the engine stops. Combine such "engine-stop" draws with hot temperature, and a battery can go from fully charged to completely discharged in a matter of days.

Self-discharge		
Temperature	Approx. Number of Days from 100% charged to 100% discharged	
	Lead-Antimony	Lead-Calcium
	Battery	Battery
40°C (104°F)	100 Days	300 Days
25°C (77°F)	200 Days	600 Days
0°C (32°F)	550 Days	950 Days

Current Drain		
Discharging Ampere	Days from 100% charged to 50% discharged	Days from 100% charged to 100% discharged
7 mA	60 Days	119 Days
10 mA	42 Days	83 Days
15 mA	28 Days	56 Days
20 mA	21 Days	42 Days
30 mA	14 Days	28 Days

In extremely cold weather the fluid in an inadequately charged battery can easily freeze, which can crack the case and buckle the plates. A fully charged battery can withstand sub-freezing temperatures with no damage.

Battery Sulfation

A common cause of battery failure is sulfation.

Sulfation occurs when the battery is left in a discharged condition for an extended time. Sulfate is a normal by product of the chemical reactions within a battery. But when continuous discharge allows the sulfate to crystallize in the cells, the battery plates become permanently damaged and will not hold a charge. Battery failure due to sulfation is not warrantable.

Battery Maintenance

It is the owner’s responsibility to keep the battery fully charged. Failure to do so can lead to battery failure and leave you stranded.

If you are riding your vehicle infrequently, inspect the battery voltage weekly using a voltmeter. If it drops below 12.6 volts, the battery should be charged using an appropriate charger (check with your Kawasaki dealer). If you will not be using the motorcycle for longer than two weeks, the battery should be charged using an appropriate charger. Do not use an automotive-type quick charger that may overcharge the battery and damage it.

NOTE

○ *Leaving the battery connected causes the electrical components to make the battery discharged, resulting in the over discharge of the battery. In this case, the repair or replacement of the battery is not included in the warranty. If you do not drive for four weeks or more, disconnect the battery from the vehicle.*

Kawasaki-recommended chargers are:

- Battery Mate 150-9
- OptiMate 4
- Yuasa MB-2040/2060
- Christie C10122S

If the above chargers are not available, use equivalent one.

For more details, ask your Kawasaki dealer.

Battery Charging

- Remove the battery from the motorcycle (see Battery Removal).
- Attach the leads from the charger and charge the battery at a rate (amperage × hours) that is indicated on the battery. If it is not possible to read the rate, charge the battery at an amperage that is about 1/10th of the battery capacity.
- The charger will keep the battery fully charged until you are ready to reinstall the battery in the motorcycle (see Battery Installation).

NOTICE
Do not install a conventional battery in this motorcycle, or the electrical system cannot work properly.

Make	Siam Furukawa
Type	FTX7L-BS

80 MAINTENANCE AND ADJUSTMENT

NOTE

○ If you charge the sealed battery, never fail to observe the instructions shown in the label on the battery.

Battery Removal

- Remove the bolt and remove the side cover.

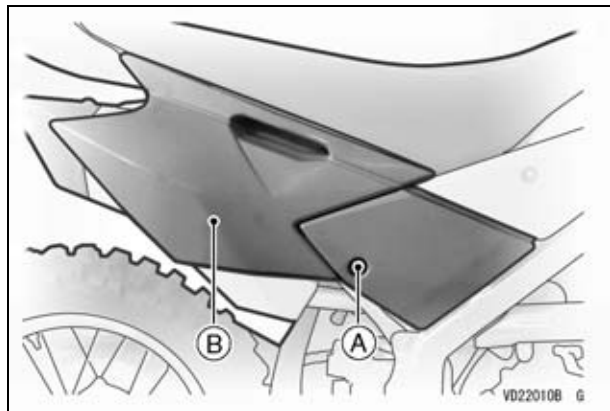

- A. Bolt
- B. Side Cover

- Remove the bolt and remove the seat.

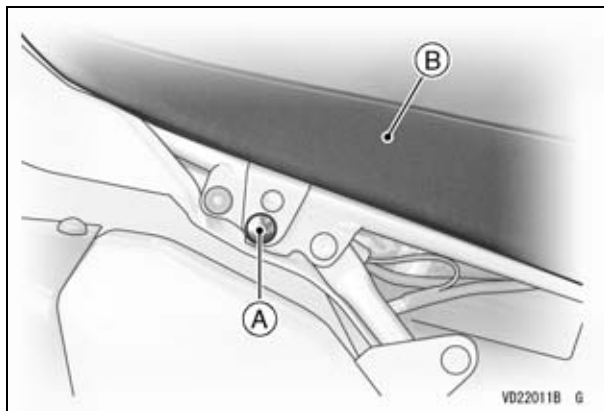

- A. Bolt
- B. Seat

- Disconnect the cable from the battery, first from the (–) terminal and then the (+) terminal.

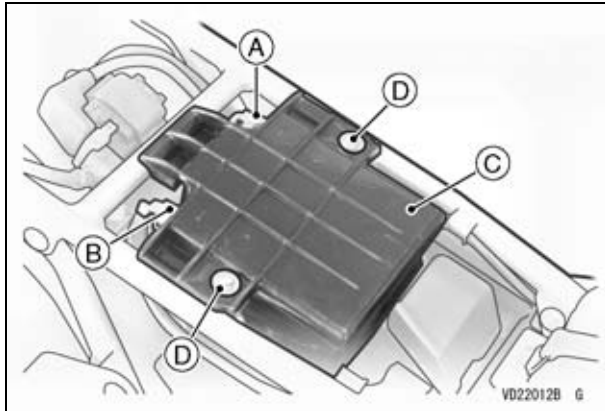

- A. (+) Terminal**
- B. (–) Terminal**
- C. Battery Holder**
- D. Bolts**

- Take out battery holder by removing the bolt.
- Take the battery out of the case.
- Clean the battery using a solution of baking soda and water. Be sure that the cable connections are clean.

Battery Installation

- Place the battery in the battery case.
- Install the battery holder and tighten the bolts.
- Connect the red cable to the (+) terminal, and then connect the black cable to the (–) terminal.

NOTE

- *Install the battery in the reverse order of the Battery Removal.*

NOTICE

Installing the (–) cable to the (+) terminal of the battery or the (+) cable to the (–) terminal of the battery can seriously damaged the electrical system.

- Put a light coat of grease on the terminals to prevent corrosion.
- Reinstall the parts removed.

82 MAINTENANCE AND ADJUSTMENT

Fuse

The main fuse (10 A) is mounted on the starter relay under the seat. If a fuse fails during operation, inspect the electrical system to determine the cause, and then replace it with a new fuse of proper amperage.

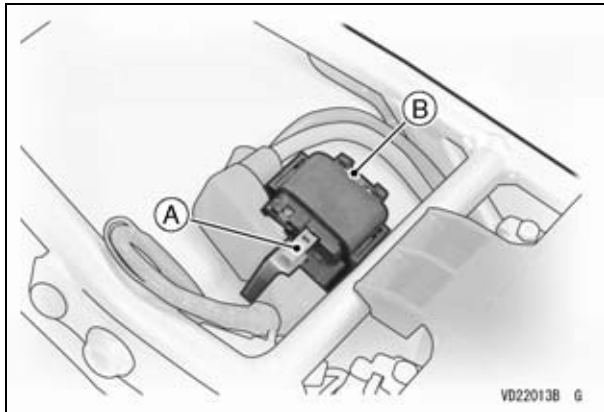

A. Main Fuse (10 A)
B. Spare Fuse

WARNING

Substituting fuses can cause wiring to over-heat, catch fire and/or fail. Do not use any substitute for the standard fuse. Replace the blown fuse with a new one of the correct capacity, as specified on the junction box and main fuse.

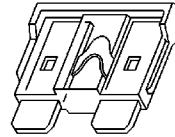

Normal

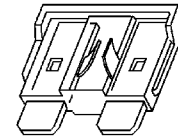

Failed

Tightening Torques of Nuts and Bolts

Location of nuts and bolts

Before the first ride of each day of operation, check the tightness of the nuts and bolts shown below. Check also that all cotter pins are in place and in good condition.

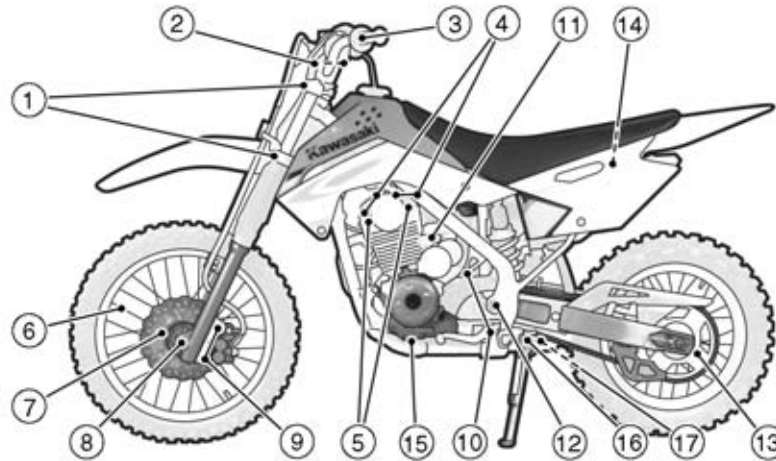

1. Front Fork Clamp Bolts
2. Handlebar Clamp Bolts
3. Clutch Lever Holder Bolt
4. Valve Adjusting Cap Bolts
5. Camshaft Cap Bolts
6. Spokes
7. Front Brake Disc Mounting Bolts
8. Front Axle Nut
9. Front Brake Caliper Bolts

10. Engine Mounting Bolts and Nuts
11. Camshaft Chain Tensioner Bolts
12. Swingarm Pivot Shaft Nut
13. Rear Sprocket Nut
14. Seat Bolt
15. Engine Oil Drain Plug
16. Side Stand Bolt
17. Side Stand Nut

84 MAINTENANCE AND ADJUSTMENT

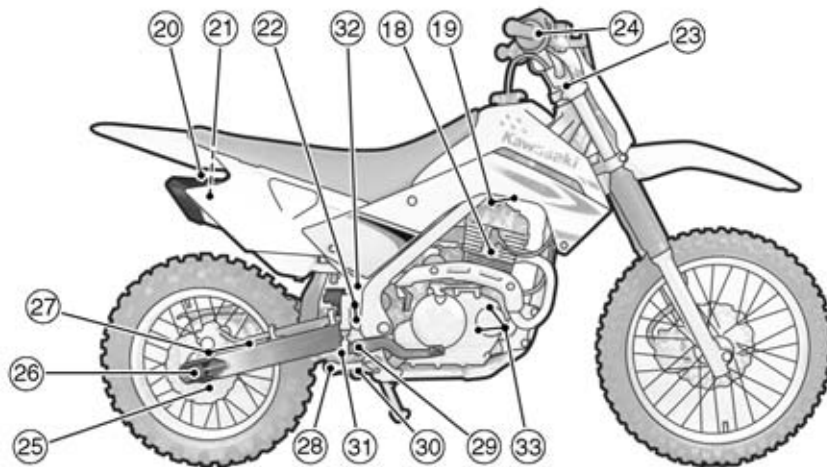

VD23024B 6

- 18. Spark Plug
- 19. Cylinder Head Bolts
- 20. Muffler End Mounting Bolts
- 21. Spark Arrester Mounting Bolts
- 22. Rear Master Cylinder Mounting Bolts
- 23. Steering Head Nut
- 24. Front Master Cylinder Mounting Bolts
- 25. Rear Brake Disk Mounting Bolts

- 26. Rear Axle Nut
- 27. Rear Brake Caliper Bolts
- 28. UNI-TRAK® Lever Rod Bolt
- 29. Rear Brake Pedal Pivot Bolt
- 30. Rear Shock Absorber Bolt and Nut
- 31. UNI-TRAK Arm Bolt
- 32. Rear Frame Bolts
- 33. Oil Filter Cover Bolts

Torque table

Tighten all nuts and bolts to the proper torque using an accurate torque wrench. An insufficiently tightened nut or bolt may become damaged or fall out, possibly resulting in damage to the motorcycle and injury to the rider. An overtightened nut or bolt may become damaged, broken, or fall out.

Part Name		N·m	kgf·m	ft·lb
ENGINE	Cylinder Head Cover Bolts	8.8	0.9	(78 in·lb)
	Cylinder Head Bolts (M8)	22	2.2	16
	(M6)	16	1.6	12
	Camshaft Chain Tensioner Bolts	5.2	0.53	(46 in·lb)
	Camshaft Cap Bolts	8.8	0.9	(78 in·lb)
	Engine Oil Drain Plug	18	1.8	13
	Oil Filter Cover Bolts	8.8	0.9	(78 in·lb)
	Spark Plug	13	1.3	9.6
	Generator Cover Bolts	8.8	0.9	(78 in·lb)
	Shift Pedal Tie Rod	9.8	1.0	(87 in·lb)
(Left hand threads)	9.8	1.0	(87 in·lb)	

86 MAINTENANCE AND ADJUSTMENT

Part Name		N·m	kgf·m	ft·lb
CHASSIS	Brake Caliper Bolts (Front)	34	3.5	25
	(Rear)	25	2.5	18
	Brake Disc Mounting Bolts (Front)	9.8	1.0	(87 in·lb)
	(Rear)	9.8	1.0	(87 in·lb)
	Engine Bracket Nut/Bolt M8	29	3.0	21
	M10	49	5.0	36
	Engine Mounting Bolts	49	5.0	36
	Front Axle Nut	79	8.1	58
	Front Fork Clamp Bolts	20	2.0	14
	Handlebar Clamp Bolts	25	2.5	18
	Side Stand Bolt	29	3.0	21
	Side Stand Nut	44	4.5	32
	Swingarm Pivot Shaft Nut	108	11.0	80
	Rear Axle Nut	79	8.1	58
	Rear Brake Pedal Pivot Bolt	25	2.5	18
	Rear Frame Bolts	34	3.5	25
Rear Shock Absorber Upper Bolt	39	4.0	29	

MAINTENANCE AND ADJUSTMENT 87

Part Name		N·m	kgf·m	ft·lb
CHASSIS	Rear Shock Absorber Lower Nut	29	3.0	21 (KLX140A)
	Rear Shock Absorber Lower Bolt	39	4.0	29 (KLX140B)
	Spokes	2.0	0.2	(18 in·lb)
	Steering Stem Head Nut	64	6.5	47
	Steering Stem Locknut	4.9	0.5	(43 in·lb)
	UNI-TRAK [®] Arm Bolt	59	6.0	44
	UNI-TRAK [®] Rod Bolts	59	6.0	44
	Rear Sprocket Nuts	32	3.3	24
	Front Brake Master Cylinder Clamp Bolts	8.8	0.9	(78 in·lb)
	Rear Brake Master Cylinder Mounting Bolts	10	1.0	(88 in·lb)

Cleaning Your Motorcycle

General Precautions

Frequent and proper care of your Kawasaki motorcycle will enhance its appearance, optimize overall performance, and extend its useful life. Covering your motorcycle with a high quality, breathable motorcycle cover will help protect its finish from harmful UV rays, pollutants, and reduce the amount of dust reaching its surfaces.

WARNING

Build-up of debris or flammable material in and around the vehicle chassis, engine, and exhaust can cause mechanical problems and increase the risk of fire. When operating the vehicle in conditions that allow debris or flammable material to collect in and around the vehicle, inspect the engine, electrical component and exhaust areas frequently. If debris or flammable materials have collected, park the vehicle outside and stop the engine. Allow the engine to cool, then remove any collected debris. Do not park or store the vehicle in an enclosed space prior to inspecting for build-up of debris or flammable materials.

- Be sure the engine and exhaust are cool before washing.

- Avoid applying degreaser to seals, brake pads, and tires.
- Always use non-abrasive wax and cleaner/polisher.
- Avoid all harsh chemicals, solvents, detergents, and household cleaning products such as ammonia-based window cleaners.
- Gasoline, brake fluid, and coolant will damage the finish of painted and plastic surfaces: wash them off immediately.
- Avoid wire brushes, steel wool, and all other abrasive pads or brushes.
- Use care when washing the plastic parts as they can easily be scratched.
- Avoid using pressure washers; water can penetrate seals and electrical components and damage your motorcycle.
- Avoid spraying water in delicate areas such as in air intakes, carburetors, brake components, electrical components, muffler outlets, and fuel tank openings.

Washing Your Motorcycle

- Rinse your bike with cold water from a garden hose to remove any loose dirt.
- Mix a mild neutral detergent (designed for motorcycles or automobiles) and water in bucket. Use a soft cloth or sponge to wash your motorcycle. If needed, use a mild degreaser to remove any oil or grease build up.

- After washing, rinse your motorcycle thoroughly with clean water to remove any residue (residue from the detergent can damage parts of your motorcycle).
- Use a soft cloth to dry your motorcycle. As you dry, inspect your motorcycle for chips and scratches. Do not let the water air dry as this can damage the painted surfaces.
- After cleaning your motorcycle, check the rubber boot covering the shift pedal ball joint for correct installation. Be sure the sealing lip of the rubber boot fits into the groove of the ball joint.

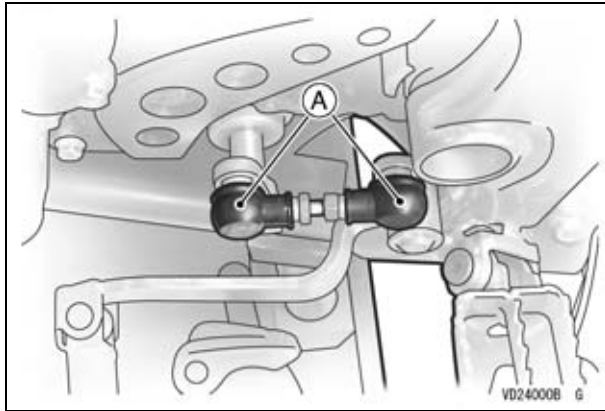

A. Boots

- If the boot is damaged, replace it with a new one. If the boot is not positioned in the groove correctly, replace it in the correct position.

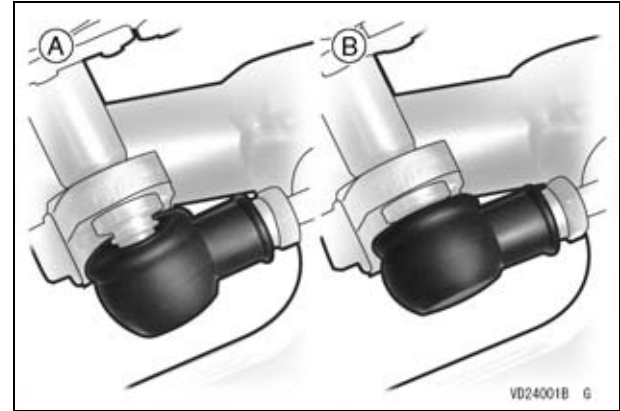

**A. Wrongly set lip not in the correct position
B. Lip set correctly in the groove**

- Start the engine and let it idle for several minutes. The heat from the engine will help dry moist areas.
- Carefully ride your motorcycle at a slow speed and apply the brakes several times. This helps dry the brakes and restores them to normal operating performance.
- Lubricate the drive chain to prevent rusting.

90 MAINTENANCE AND ADJUSTMENT

NOTE

- *The front fork may have a scratch by the spattered stones, etc. but it is no effect for the performance of the front fork. After riding in an area where the roads are salted or near the ocean, immediately wash your motorcycle with cold water. Do not use warm water as it accelerates the chemical reaction of the salt. After drying, apply a corrosion protection spray on all metal and chrome surfaces to prevent corrosion.*

Semi-gloss Finish

To clean the semi-gloss finish;

- When washing the motorcycle, always use a mild neutral detergent and water.
- The semi-gloss finish effect may be lost when the finish is excessively rubbed.
- If any doubt, consult an authorized Kawasaki dealer.

Painted Surfaces

After washing your motorcycle, coat painted surfaces, both metal and plastic, with a commercially available motorcycle/automotive wax. Wax should be applied once every three months or as conditions require. Avoid surfaces with “satin” or “flat” finishes. Always use nonabrasive products and apply them according to the instructions on the container.

Plastic Parts

After washing use a soft cloth to gently dry plastic parts. When dry, treat the non-painted plastic parts with an approved plastic cleaner/polisher product.

NOTICE

Plastic parts may deteriorate and break if they come in contact with chemical substances or household cleaning products such as gasoline, brake fluid, window cleaners, thread-locking agents, or other harsh chemicals. If a plastic part comes in contact with any harsh chemical substance, wash it off immediately with water and a mild neutral detergent, and then inspect for damage. Avoid using abrasive pads or brushes to clean plastic parts, as they will damage the part's finish.

Chrome and Aluminum

Chrome and uncoated aluminum parts can be treated with a chrome/aluminum polish. Coated aluminum should be washed with a mild neutral detergent and finished with a spray polish. Aluminum wheels, both painted and unpainted can be cleaned with special non-acid based wheel spray cleaners.

Leather, Vinyl, and Rubber

If your motorcycle has leather accessories, special care must be taken. Use a leather cleaner/treatment to clean and care for leather accessories. Washing leather parts with detergent and water will damage them, shortening their life.

Vinyl parts should be washed with the rest of the motorcycle, then treated with a vinyl treatment.

The sidewalls of tires and other rubber components should be treated with a rubber protectant to help prolong their useful life.

⚠ WARNING

Rubber protectants can be slippery and, if used on the tread area, cause loss of traction resulting in accident causing injury or death. Do not apply rubber protectant to any tread area.

Lubrication

Lubricate the areas shown in the illustrations of this section with either motor oil or regular grease, after each race and whenever the vehicle has been operated under wet or rainy conditions, especially after using a high-pressure spray washer. Before lubricating a part, clean off any rust with rust remover and wipe off any grease, oil, dirt, or grime.

General Lubrication

Apply motor oil or grease to the following pivots:

- Clutch lever
- Front brake lever



92 MAINTENANCE AND ADJUSTMENT

- Rear brake pedal
- Rear brake rod joints
- Foot peg

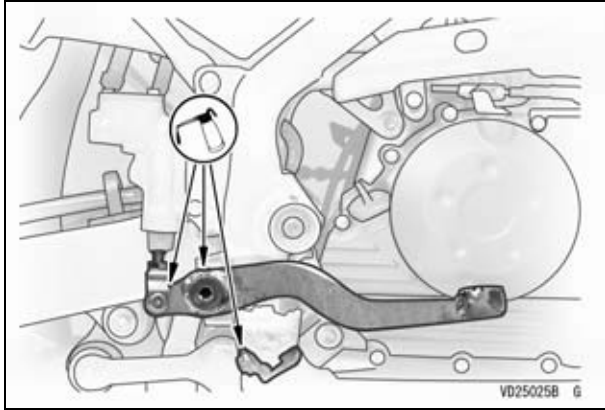

Apply an aerosol cable lubricant with a pressure lubricator on all cables:

- Clutch cable
- Throttle cable
- Hot starter cable

Cable Lubrication

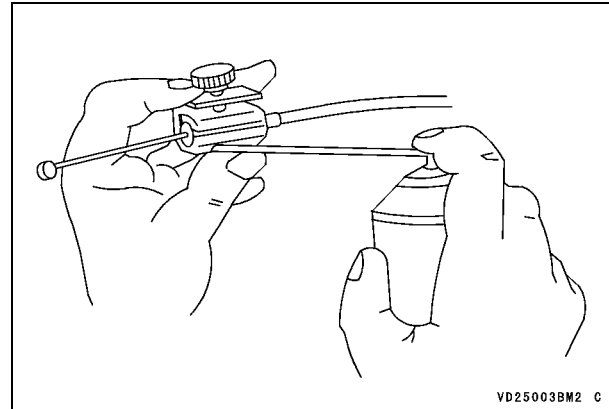

Apply grease to the following points:

- Upper end of clutch cable
- Upper end of throttle cable
- Upper end of hot starter cable
- Shift pedal

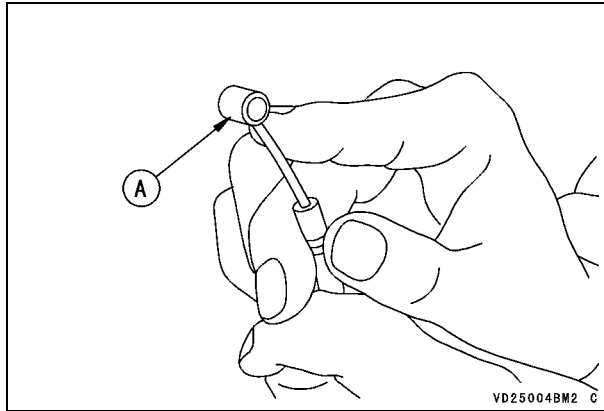

A. Grease.

Drive Chain Lubrication

Lubrication is necessary after riding through rain or on wet roads, or any time that the chain appears dry.

Use a chain lubricant for motorcycle. If the chain is especially dirty, clean it using a cleaner following the instructions supplied by the chain cleaner manufacturer.

- Apply lubricant to the sides of the rollers so that it will penetrate to the rollers and bushings. Wipe off any excess lubricant.

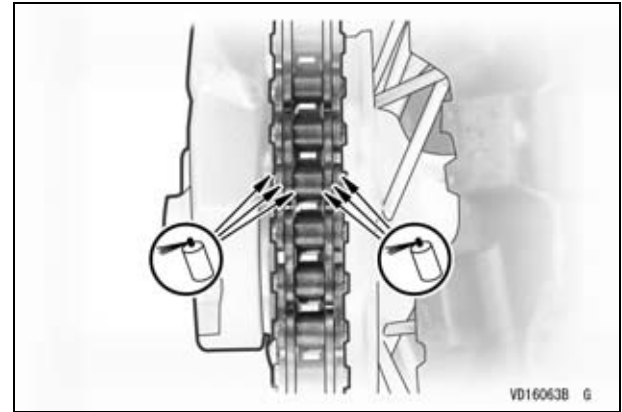

- Wipe off any lubricant that gets on the tire surface.

TROUBLESHOOTING GUIDE

NOTE

○ *This troubleshooting guide is not exhaustive and does not give every possible cause for each problem listed. It is meant simply as a quick guide to assist you in troubleshooting for some of the more common difficulties.*

Starting failure or difficulties –

Engine does not turn over

- Transmission not in neutral
- Engine stop switch set to OFF

Compression low

- Spark plug loose

Spark missing or weak

- Spark plug faulty
- Spark plug cap poorly connected or shorted

Fuel does not flow

- No fuel in tank
- Fuel hose clogged
- Fuel tap clogged

Engine flooded

- Starting technique faulty

Poor low-speed performance –

Spark weak

- Spark plug faulty
- Spark plug gap excessive

Fuel-air mixture incorrect

- Idle adjusting screw improperly adjusted
- Air cleaner element clogged

Compression low

- Spark plug loose

Poor or no high-speed performance –

Fuel-air mixture incorrect

- Air cleaner element clogged
- Air cleaner duct loose

Misfiring

- Spark plug worn
- Spark plug cap poorly connected or shorted

Knocking

- Fuel poor quality

Other

- Brake dragging
- Engine overheating
- Engine overheating
- Throttle valve does not fully open
- Engine oil quality excessive
- Engine oil viscosity too high

Engine overheating –

- Brake dragging
- Clutch slipping

Clutch not operating smoothly –

Clutch slipping

- Friction plate worn
- Clutch springs weak

Clutch doesn't disengaging properly

- Engine oil deteriorated
- Engine oil viscosity too high

Poor handling and/or stability –

Handlebar hard to turn

- Steering stem locknut too tight
- Tire air pressure too low
- Steering stem lubrication insufficient

Handlebar vibrates or shakes

- Swingarm bent
- Front fork bent
- Frame bent
- Wheel alignment incorrect
- Pivot shaft warped
- Right/left front fork oil level uneven

Shock absorption too hard

- Tire air pressure too high

Shock absorption too soft

- Tire air pressure too low
- Front fork spring worn
- Front fork and/or rear shock absorber oil leaking

Poor braking performance –

- Air in the brake line
- Brake pad or disc worn
- Brake fluid leaking
- Brake disc warped
- Brake pads contaminated
- Brake fluid deteriorated
- Primary and/or secondary master cylinder cup(s) damaged
- Master cylinder scratched
- Brake maladjusted (lever or pedal play excessive)

STORAGE

Before Storage

When the motorcycle is to be stored for any length of time, it should be prepared for storage as follows.

- Clean the entire vehicle thoroughly.
- Run the engine for about five minutes to warm the oil, then stop it and drain the engine oil.

WARNING

Engine oil is a toxic substance. Dispose of used oil properly. Contact your local authorities for approved disposal methods or possible recycling.

- Install the oil drain plugs and fill in fresh engine oil.
- Empty the fuel tank and the carburetor float bowl. (Fuel will deteriorate if left for a long time.)

WARNING

Gasoline is extremely flammable and can be explosive under certain conditions, creating the potential for serious burns. Always stop the engine and never smoke while handling fuel. Make sure the area is well-ventilated and free from any source of flame or sparks; this includes any appliance with a pilot light. Make sure the engine is cold before working. Wipe any fuel off the engine before starting it. Gasoline is a toxic substance. Dispose of gasoline properly. Contact your local authorities for approved disposal methods.

- Remove the spark plug and spray fogging oil directly into the cylinder. Kick the engine over slowly a few times to coat the cylinder wall. Install the spark plug.
- Lubricate the drive chain and all the cables.
- Spray oil on all unpainted metal surfaces to prevent rusting. Avoid getting oil on rubber parts and on the brakes.
- Lift the motorcycle on a box or stand so that both wheels are raised off the ground. (If this cannot be done, put boards under the front and rear wheels to keep dampness away from the tire rubber.)
- Tie a plastic bag over the muffler to prevent moisture from entering.
- Cover the motorcycle to keep dust and dirt away from it.

After Storage

- Remove the plastic bag from the muffler.
- Make sure the spark plug is tight.

NOTE

- *Fit the plug cap securely onto the spark plug, and pull the cap lightly to make sure that it is properly installed.*
- Fill the fuel tank with fuel.
- Check all the points listed in the Daily pre-ride checks section.
- Perform a General Lubrication Procedure.

ENVIRONMENTAL PROTECTION

Off-road motorcycling is a wonderful sport, and we hope you will enjoy it to the fullest. However, if improperly conducted, this sport has the potential to cause environmental problems as well as conflicts with other people.

Responsible use of your vehicle will ensure that these problems and conflicts do not occur. TO PROTECT THE FUTURE OF YOUR SPORT, MAKE SURE YOU USE YOUR VEHICLE LEGALLY, SHOW CONCERN FOR THE ENVIRONMENT, AND RESPECT THE RIGHTS OF OTHER PEOPLE.

To help preserve the environment, properly discard used batteries, tires, oils and fluids, or other vehicle components that you might dispose of in the future. Consult your authorized Kawasaki dealer or local environmental waste agency for their proper disposal procedure. This also applies to disposal of the entire vehicle at the end of its life.

Also take special care not to spill fuel, oil or other fluids onto the ground.

WIRING DIAGRAM

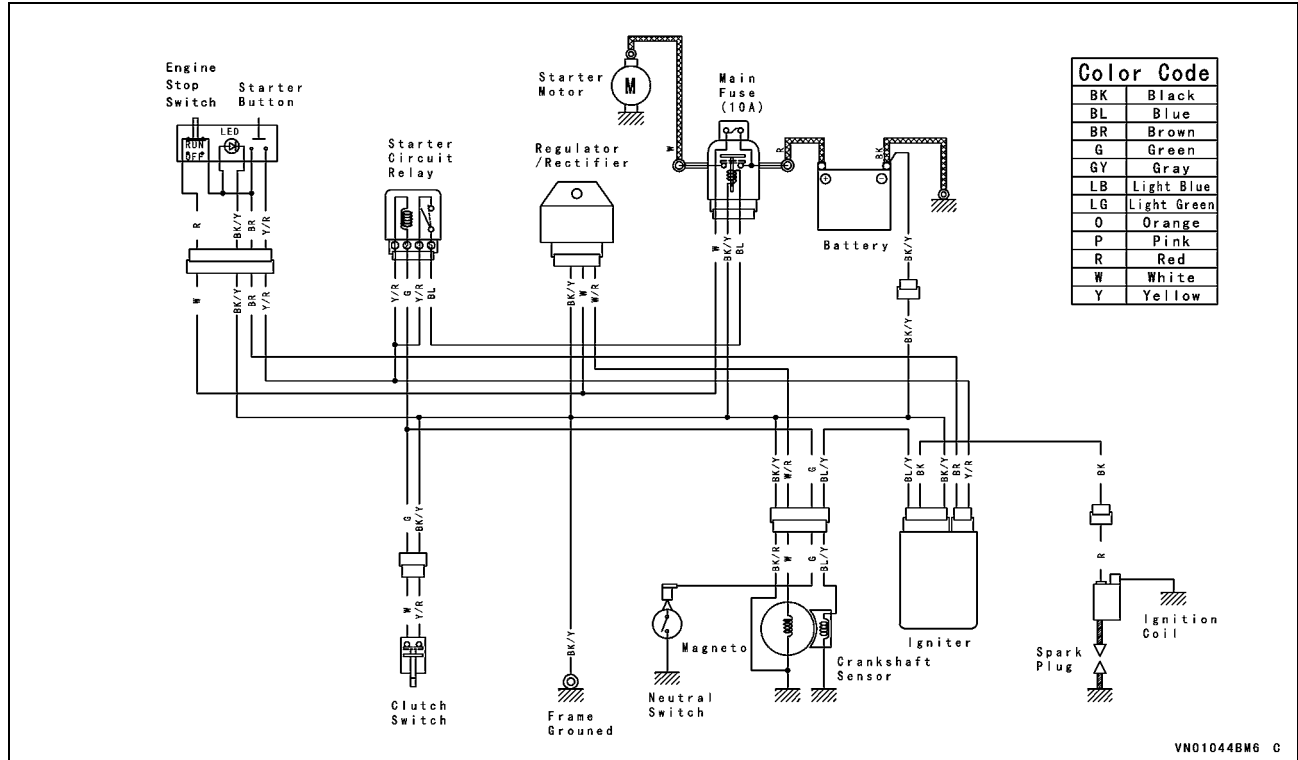

KLX140AF/BF

