



Kawasaki

ZZ-R250

1990 - 1996



**Motorcycle
Service Manual
Supplement**

Aug 1997

MODEL APPLICATION

Year	Model	Beginning Frame No.
1990	EX250-H1	JKAEXMH1 □ LA000001, or EX250H-000001
1991	EX250-H2	JKAEXMH1 □ MA008801, or EX250H-008801
1992	EX250-H3	JKAEXMH1 □ NA025001, or EX250H-025001
1993	EX250-H4	EX250H-033001
1994	EX250-H5	JKAEXMH1 □ RA050001, or EX250H-050001
1996	EX250-H7	JKAEXMH1 □ TA060001, or EX250H-060001

□ :This digit in the frame number changes from one machine to another.



KAWASAKI HEAVY INDUSTRIES, LTD.
Consumer Products Group

Part No. 99924-1129-54

Printed in Japan

Quick Reference Guide

General Information	1
Fuel System	2
Cooling System	3
Engine Top End	4
Clutch	5
Engine Lubrication System	6
Engine Removal / Installation	7
Crankshaft / Transmission	8
Wheels / Tires	9
Final Drive	10
Brakes	11
Suspension	12
Steering	13
Frame	14
Electrical System	15
Appendix	16

This quick reference guide will assist you in locating a desired topic or procedure.

- Bend the pages back to match the black tab of the desired chapter number with the black tab on the edge at each table of contents page.
- Refer to the sectional table of contents for the exact pages to locate the specific topic required.

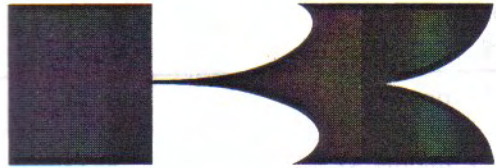

Kawasaki

ZZ-R250

Motorcycle Service Manual Supplement

All rights reserved. No parts of this publication may be reproduced, stored in a retrieval system, or transmitted in any form or by any means, electronic mechanical photocopying, recording or otherwise, without the prior written permission of Quality Assurance Department/Consumer Products Group/Kawasaki Heavy Industries, Ltd., Japan.

No liability can be accepted for any inaccuracies or omissions in this publication, although every possible care has been taken to make it as complete and accurate as possible.

The right is reserved to make changes at any time without prior notice and without incurring an obligation to make such changes to products manufactured previously. See your Motorcycle dealer for the latest information on product improvements incorporated after this publication.

All information contained in this publication is based on the latest product information available at the time of publication. Illustrations and photographs in this publication are intended for reference use only and may not depict actual model component parts.

LIST OF ABBREVIATIONS

A	ampere(s)	lb	pound(s)
ABDC	after bottom dead center	m	meter(s)
AC	alternating current	min	minute(s)
ATDC	after top dead center	N	newton(s)
BBDC	before bottom dead center	Pa	pascal(s)
BDC	bottom dead center	PS	horsepower
BTDC	before top dead center	psi	pound(s) per square inch
°C	degree(s) Celsius	r	revolution
DC	direct current	rpm	revolution(s) per minute
F	farad(s)	TDC	top dead center
°F	degree(s) Fahrenheit	TIR	total indicator reading
ft	foot, feet	V	volt(s)
g	gram(s)	W	watt(s)
h	hour(s)	Ω	ohm(s)
L	liter(s)		

This warning may apply to any of the following components or any assembly containing one or more of these components:-



Brake Shoes or Pads
Clutch Friction Material
Gaskets
Insulators

SAFETY INSTRUCTIONS

- Operate if possible out of doors or in a well ventilated place.
- Preferably use hand tools or low speed tools equipped, if necessary, with an appropriate dust extraction facility. If high speed tools are used, they should always be so equipped.
- If possible, dampen before cutting or drilling.
- Dampen dust and place it in properly closed receptacle and dispose of it safely.

Read OWNER'S MANUAL before operating.

Foreword

This EX250H Service Manual Supplement is designed to be used in conjunction with the EX250E Motorcycle Service Manual (P/N 99924-1066-01). The maintenance and repair procedures described in this supplement are only those that are unique to the EX250H motorcycle. Most service operations for these models remain identical to those described in the base Service Manual. Complete and proper servicing of the EX250H motorcycle therefore requires both this supplement and the base Service Manual.

This manual is designed primarily for use by trained mechanics in a properly equipped shop. However, it contains enough detail and basic information to make it useful to the owner who desires to perform his own basic maintenance and repair work. A basic knowledge of mechanics, the proper use of tools, and workshop procedures must be understood in order to carry out maintenance and repair satisfactorily. Whenever the owner has insufficient experience or doubts his ability to do the work, all adjustments, maintenance, and repair should be carried out only by qualified mechanics.

In order to perform the work efficiently and to avoid costly mistakes, read the text, thoroughly familiarize yourself with the procedures before starting work, and then do the work carefully in a clean area. Whenever special tools or equipment are specified, do not use makeshift tools or equipment. Precision measurements can only be made if the proper instruments are used, and the use of substitute tools may adversely affect safe operation.

For the duration of your warranty period, especially, we recommend that all repairs and scheduled maintenance be performed in accordance with this service manual. Any owner maintenance or repair procedure not performed in accordance with this manual may void the warranty.

To get the longest life out of your Motorcycle:

- Follow the Periodic Maintenance Chart in the Service Manual.
- Be alert for problems and non-scheduled maintenance.
- Use proper tools and genuine Kawasaki Motorcycle parts. Special tools, gauges, and testers that are necessary when servicing Kawasaki Motorcycles are introduced by the Special Tool Manual. Genuine parts provided as spare parts are listed in the Parts Catalog.
- Follow the procedures in this manual carefully. Don't take shortcuts.

- Remember to keep complete records of maintenance and repair with dates and any new parts installed.

How to Use this Manual

In preparing this manual, we divided the product into its major systems. These systems became the manual's chapters. All information for a particular system from adjustment through disassembly and inspection is located in a single chapter.

The Quick Reference Guide shows you all of the product's systems and assists in locating their chapters. Each chapter in turn has its own comprehensive Table of Contents.

The Periodic Maintenance Chart is located in the General Information chapter. The chart gives a time schedule for required maintenance operations.

If you want spark plug information, for example, go to the Periodic Maintenance Chart first. The chart tells you how frequently to clean and gap the plug. Next, use the Quick Reference Guide to locate the Electrical System chapter. Then, use the Table of Contents on the first page of the chapter to find the Spark Plug section.

Whenever you see these WARNING and CAUTION symbols, heed their instructions! Always follow safe operating and maintenance practices.

▲WARNING

This warning symbol identifies special instructions or procedures which, if not correctly followed, could result in personal injury, or loss of life.

CAUTION

This caution symbol identifies special instructions or procedures which, if not strictly observed, could result in damage to or destruction of equipment.

General Information

Table of Contents

Before Servicing	*
Model Identification	1-2
General Specifications	1-3
Torque and Locking Agent	1-5
Cable, Wire, Hose, and Pipe Routing	1-8
Periodic Maintenance Chart	1-12

* : Refer to Base Manual 1986 - 87

Quick Reference

1-2 GENERAL INFORMATION

Model Identification

EX250-H1/H2



EX250-H3/H4



EX250-H5



EX250-H7



General Specifications

Item	EX250-H1/H2/H3/H4/H5/H7	
Dimensions:		
Overall length	2 050 mm, (F)(G)(S) 2 115 mm	
Overall width	700 mm	
Overall height	1 125 mm	
Wheelbase	1 405 mm	
Road clearance	135 mm	
Seat height	760 mm	
Dry weight	148 kg, (A) 146 kg	
Curb weight:	Front	80 kg
	Rear	90 kg, (A) 88 kg
Fuel tank capacity	18.0 L	
Performance:		
Minimum turning radius	2.8 m	
Engine:		
Type	4-stroke, DOHC, 2-cylinder	
Cooling system	Liquid-cooled	
Bore and stroke	62.0 x 41.2 mm	
Displacement	248 mL	
Compression ratio	12.4	
Maximum horsepower	26.5 kW (36 PS) @12 500 r/min (rpm), (S) 14.7 kW (20 PS) @9 500 r/min (rpm)	
Maximum torque	21.6 N-m (2.2 kg-m, 15.9 ft-lb) @9 000 r/min (rpm), (S) 15.7 N-m (1.6 kg-m, 11.6 ft-lb) @8 000 r/min (rpm)	
Carburetion system	Carburetors, Keihin CVK30 x 2	
Starting system	Electric starter	
Ignition system	Battery and coil (transistorized)	
Timing advance	Electronically advanced	
Ignition timing	From 10° BTDC @1 200 r/min (rpm) to 42° BTDC @4 500 r/min (rpm), (S) From 10° BTDC @1 300 r/min (rpm) to 42° BTDC @4 500 r/min (rpm)	
Spark plug	NGK CR8HSA or ND U24FSR-U, (A) NGK C8HA or ND U24FS-L	
Cylinder numbering method	Left to right, 1-2	
Firing order	1-2	
Valve timing:		
Inlet	Open 26° BTDC Close 66° ABDC Duration 272°	
Exhaust	Open 66° BBDC Close 26° ATDC Duration 272°	
Lubrication system	Forced lubrication (wet sump with cooler)	
Engine oil:		
Grade	SE or SF class	
Viscosity	SAE 10W-40, 10W-50, 20W-40, 20W-50	
Capacity	1.9 L	

304 lb / 368 lb

Carrying 340 lb / 188 kg

1-4 GENERAL INFORMATION

Item	EX250-H1/H2/H3/H4/H5/H7
Drive Train:	
Primary reduction system:	
Type	Gear
Reduction ratio	3.086 (71/23)
Clutch type	Wet multi disc
Transmission:	
Type	6-speed, constant mesh, return shift
Gear ratios:	
1st	2.600 (39/15)
2nd	1.789 (34/19)
3rd	1.409 (31/22)
4th	1.160 (29/25)
5th	1.000 (27/27)
6th	0.892 (25/28)
Final drive system:	
Type	Chain drive
Reduction ratio	3.357 (47/14), (AS) 3.133 (47/15)
Overall drive ratio	9.252 @Top gear, (AS) 8.636 @Top gear
Frame:	
Type	Tubular, diamond
Caster (rake angle)	26.5°
Trail	88 mm
Front tire:	
Type	Tubeless
Size	100/80-17 52S
Rear tire:	
Type	Tubeless
Size	140/70-17 66S
Front suspension:	
Type	Telescopic fork
Wheel travel	125 mm
Rear suspension:	
Type	Swingarm (uni-trak)
Wheel travel	110 mm
Brake type:	
Front	Single disc
Rear	Single disc
Electrical Equipment:	
Battery	EX250-H1 ~ H4: 12 V 8 Ah EX250-H5: 12 V 6 Ah
Headlight:	
Type	Semi-sealed beam
Bulb	12 V 60/55 W (quartz-halogen)
Tail/brake light	12 V 5/21 W
Alternator:	
Type	Three-phase AC
Rated output	17 A @10 000 r/min (rpm), 14 V

3.000
14/42

Specifications are subject to change without notice, and may not apply to every country.

- (A) : Australia Model
- (AS) : Austria Model
- (F) : Finland Model
- (G) : Greece Model
- (S) : Switzerland Model

55 mpg - 75 mpg (US)
20 km/L - 26 km/L
5 L/100km - 4 L/100km

Torque and Locking Agent

The following tables list the tightening torque for the major fasteners, and the parts requiring use of a non-permanent locking agent or liquid gasket.

Letters used in the "Remarks" column mean:

- L : Apply a non-permanent locking agent to the threads.
- O : Apply an oil to the threads, seated surface, or washer.
- S : Tighten the fasteners following the specified sequence.
- SS : Apply silicone sealant to the threads.

Fastener	Torque			Remarks
	N-m	kg-m	ft-lb	
Cooling System:				
Fan switch	18	1.8	13.0	
Water temperature sensor	7.8	0.80	69 in-lb	SS
Engine Top End:				
Cylinder head cover bolts	9.8	1.0	87 in-lb	
Camshaft cap bolts	12	1.2	104 in-lb	
Camshaft sprocket bolts	15	1.5	11.0	L
Rear chain guide bolts:				
Upper	25	2.5	18.0	
Lower	27	2.8	20	L
Chain tensioner mounting bolts	-	-	-	L
Valve adjusting screw locknuts	20	2.0	14.5	
Cylinder head bolts:				
8 mm dia.	25	2.5	18.0	S
6 mm dia.	12	1.2	104 in-lb	S
Cylinder head plugs	-	-	-	L
Clutch:				
Clutch lever holder clamp bolts	8.8	0.90	78 in-lb	
Clutch spring bolts	8.8	0.90	78 in-lb	
Clutch hub nut	130	13.5	98	
Engine Lubrication System:				
Oil pressure switch	15	1.5	11.0	SS
Oil hose banjo bolts (10 mm dia.)	20	2.0	14.5	
Oil pipe banjo bolt (8 mm dia.)	12	1.2	104 in-lb	
Crankcase oil passage plug	15	1.5	11.0	
Oil pressure relief valve	15	1.5	11.0	L
Oil pump mounting bolts	-	-	-	L
Oil drain plug	20	2.0	14.5	
Oil filter mounting bolt	20	2.0	14.5	
Engine Removal/Installation:				
Engine mounting bolt	32	3.3	23	
Engine mounting nuts	32	3.3	23	
Engine mounting bracket bolts	25	2.5	18.0	
Engine mounting bracket nuts	25	2.5	18.0	
Crankshaft/Transmission:				
Connecting rod big end cap nuts	27	2.8	20	O
Starter clutch bolts	34	3.5	26	L
Shift drum bearing holder bolts	-	-	-	L
Oil breather mounting bolts	9.8	1.0	87 in-lb	L
Crankcase bolts:				
8 mm dia.	27	2.8	20	S
6 mm dia.	12	1.2	104 in-lb	
Shift drum positioning bolt	25	2.5	18.0	

1-6 GENERAL INFORMATION

Fastener	Torque			Remarks
	N-m	kg-m	ft-lb	
Neutral switch	15	1.5	11.0	
Shift drum pin plate bolt	8.8	0.90	78 in-lb	L
External shift mechanism return spring pin	20	2.0	14.5	L
Wheels/Tires:				
Front axle nut	88	9.0	65	
Rear axle nut	110	11.0	80	
Final Drive:				
Engine sprocket bolts	9.8	1.0	87 in-lb	
Rear sprocket nuts	59	6.0	43	
Rear sprocket studs	-	-	-	L
Brakes:				
Brake lever pivot nut	5.9	0.60	52 in-lb	
Front master cylinder clamp bolts	11	1.1	95 in-lb	S
Brake hose banjo bolts	25	2.5	18.0	
Bleed valves	7.8	0.80	69 in-lb	
Front caliper mounting bolts	32	3.3	24	
Brake disc mounting bolts	23	2.3	16.5	
Brake pedal pivot bolt	8.8	0.90	78 in-lb	
Rear master cylinder mounting bolts	25	2.5	18.0	
Reservoir mounting bolt	5.9	0.60	52 in-lb	
Push rod nut	18	1.8	13.0	
Rear caliper mounting bolts	25	2.5	18.0	
Suspension:				
Front fork top plugs	23	2.3	16.5	
Front fork clamp bolts:				
Upper	20	2.0	14.5	
Lower	29	3.0	22	
Front fork bottom Allen bolts	29	3.0	22	L
Front axle clamp bolts	20	2.0	14.5	
Rear shock absorber mounting nuts	44	4.5	33	
Swing arm pivot nut	88	9.0	65	
Rocker arm pivot nut	44	4.5	33	
Tie-rod nuts	44	4.5	33	
Steering:				
Handlebar mounting bolts (EX250-H1)	23	2.3	16.5	L
Handlebar weight screws (EX250-H1)	-	-	-	L
Handlebar holder bolts	23	2.3	16.5	
Steering stem head bolt	47	4.8	35	
Steering stem nut	7.4	0.75	65 in-lb	
Frame:				
Rear frame mounting bolts	44	4.5	33	
Rear frame mounting nuts	44	4.5	33	
Side stand bracket mounting bolts	44	4.5	33	
Side stand switch screws	-	-	-	L
Center stand spring hook bolts	-	-	-	L
Front footpeg end bolts	-	-	-	L
Electrical System:				
Spark plugs	14	1.4	10.0	
Alternator stator bolts	12	1.2	104 in-lb	
Alternator rotor bolt	69	7.0	51	

The table below, relating tightening torque to thread diameter, lists the basic torque for the bolts and nuts. Use this table for only the bolts and nuts which do not require a specific torque value. All of the values are for use with dry solvent-cleaned threads.

Basic Torque for General Fasteners

Threads dia. (mm)	Torque		
	N-m	kg-m	ft-lb
5	3.4 ~ 4.9	0.35 ~ 0.50	30 ~ 43 in-lb
6	5.9 ~ 7.8	0.60 ~ 0.80	52 ~ 69 in-lb
8	14 ~ 19	1.4 ~ 1.9	10.0 ~ 13.5
10	25 ~ 34	2.6 ~ 3.5	19.0 ~ 25.0
12	44 ~ 61	4.5 ~ 6.2	33 ~ 45
14	73 ~ 98	7.4 ~ 10.0	54 ~ 72
16	115 ~ 155	11.5 ~ 16.0	83 ~ 115
18	165 ~ 225	17.0 ~ 23.0	125 ~ 165
20	225 ~ 325	23 ~ 33	165 ~ 240

- 1. Head and Neck
- 2. Main Hammer
- 3. Headlight Lens
- 4. Civil Light Lens
- 5. Horn Lens
- 6. Mounting Bracket
- 7. Horn Switch
- 8. Horn Switch Knob
- 9. Horn Switch Knob
- 10. Horn Switch Knob
- 11. Horn Switch Knob
- 12. Horn Switch Knob
- 13. Horn Switch Knob
- 14. Horn Switch Knob
- 15. Horn Switch Knob
- 16. Horn Switch Knob
- 17. Horn Switch Knob

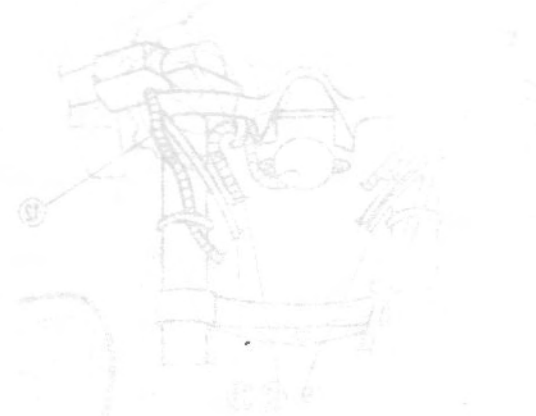

Viewed from Left



1-8 GENERAL INFORMATION

Cable, Wire, Hose, and Pipe Routing

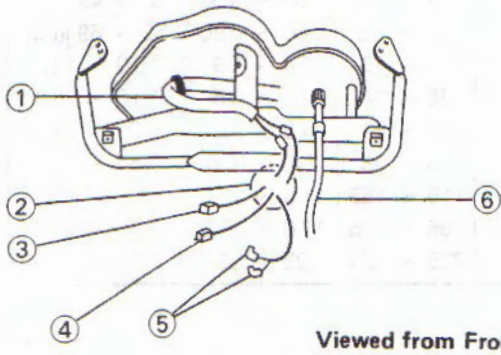

Viewed from Front

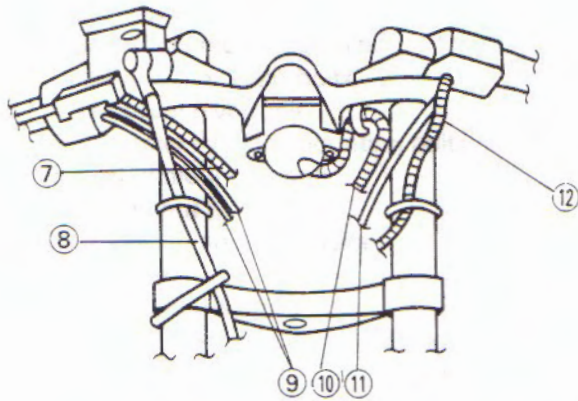

Viewed from Front

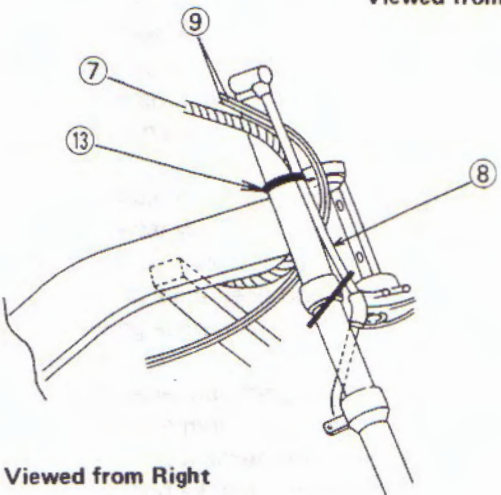

Viewed from Right

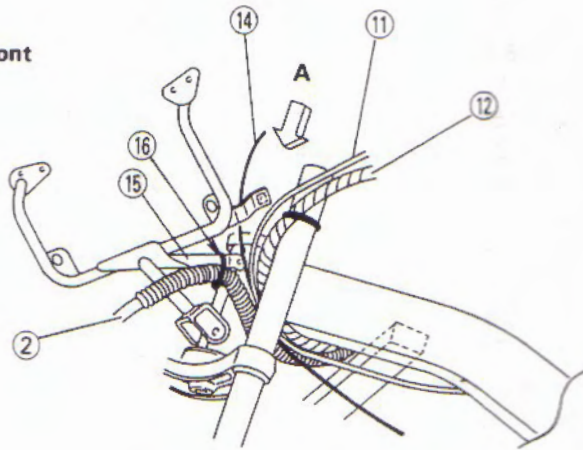

Viewed from Left

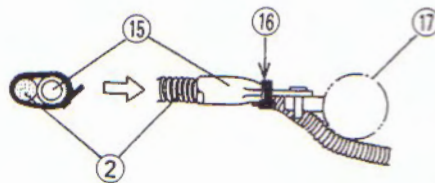

Viewed from A

1. Meter and Gauge Leads
2. Main Harness
3. Headlight Leads
4. City Light Leads
5. Horn Leads
6. Speedometer Cable
7. RH Switch Leads
8. Route brake hose at the front of fork leg.
9. Throttle Cables
10. Ignition Switch Leads
11. Choke Cable
12. LH Switch Leads
13. Clamp RH switch leads and brake hose together.
14. Clutch Cable
15. Headlight Bracket
16. Clamp at this position.
17. Head Pipe

Viewed from Left

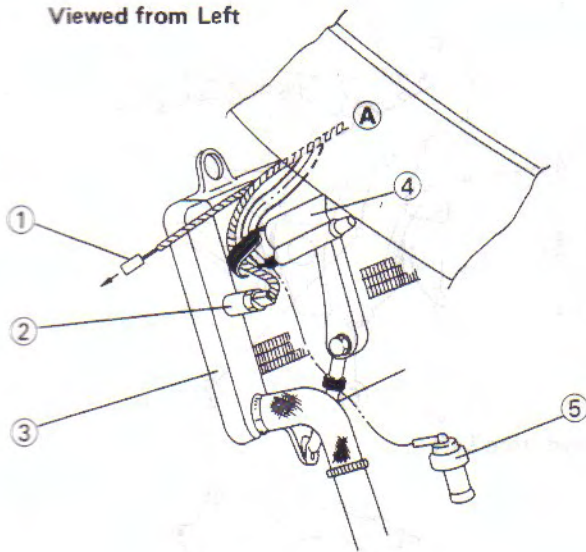

Viewed from Right

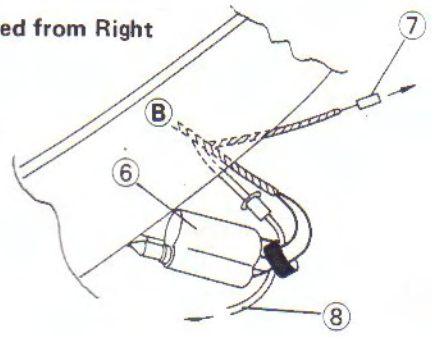

Viewed from Right

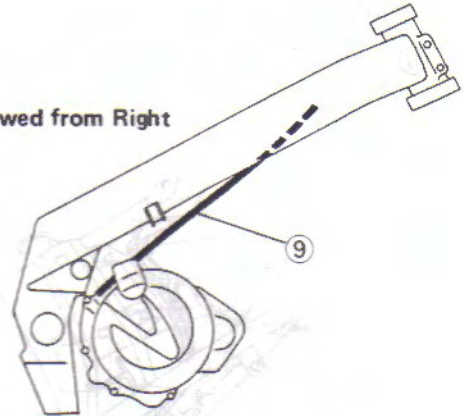

1. Left Turn Signal Light Leads
2. Radiator Fan Switch
3. Radiator
4. Ignition Coil (#1)
5. Oil Pressure Switch
6. Ignition Coil (#2)
7. Right Turn Signal Light Leads
8. Radiator Fan Leads
9. Clutch Cable
10. Choke Cable
11. Main Harness
12. LH Switch Leads
13. Ignition Switch Leads
14. Route cable beneath wiring harness.
15. Front Fork Legs
16. Throttle Cables
17. RH Switch Leads
18. Water Temperature Lead
19. Ground Lead
20. Harness Position Mark (White Tape)
21. Side Stand Switch Leads
22. Thermostat Housing

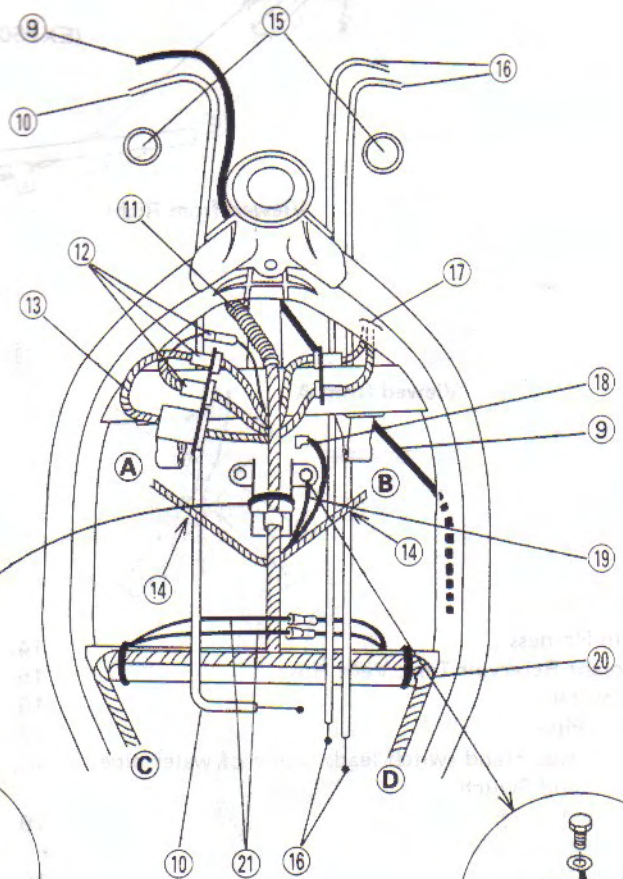

Viewed from Top

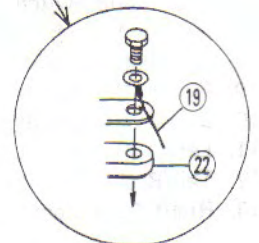
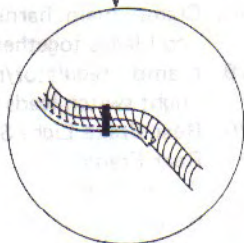

1-10 GENERAL INFORMATION

(EX250-H5, H6)

Viewed from Left

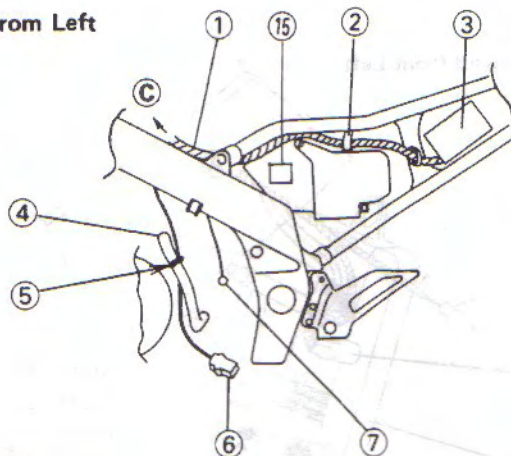

Viewed from Left

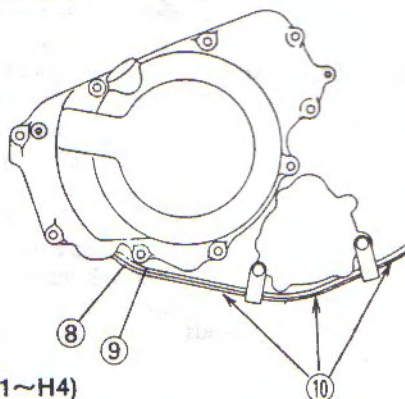

(EX250-H1~H4)

Viewed from Right

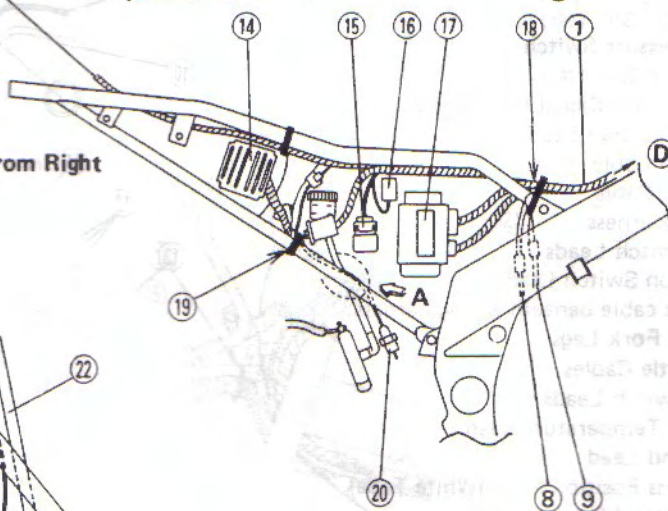

Viewed from A

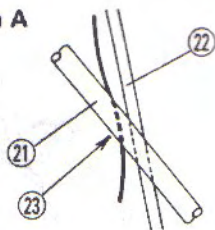

1. Main Harness
2. Coolant Reservoir Tank Vent Hose
3. IC Igniter
4. Water Pipe
5. Route side stand switch leads inside of water pipe.
6. Side Stand Switch
7. Neutral Switch
8. Alternator Leads
9. Pickup Coil Leads
10. Do not slack leads.
11. Left Turn Signal Light Leads
12. Tail/Brake Light Leads
13. Right Turn Signal Light Leads

14. Regulator/Rectifier
15. Starter Relay
16. Turn Signal Relay
17. Junction Box
18. Clamp main harness, alternator leads, and pickup coil leads together.
19. Clamp regulator/rectifier leads and rear brake light switch leads together.
20. Rear Brake Light Switch
21. Rear Frame
22. Brake Hose
23. Route rear brake light switch leads between frame and brake hose.

Viewed from Top

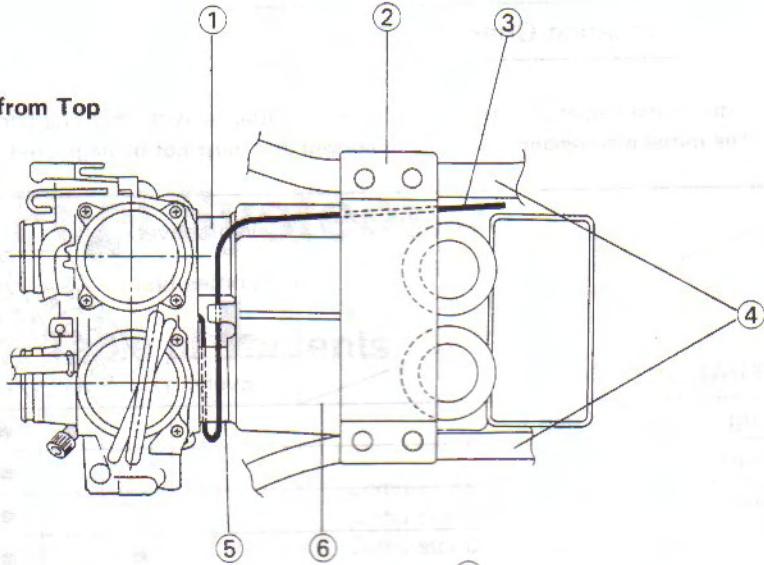

Viewed from Top

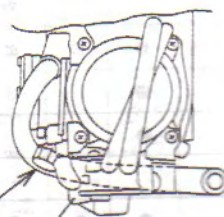

Viewed from Right

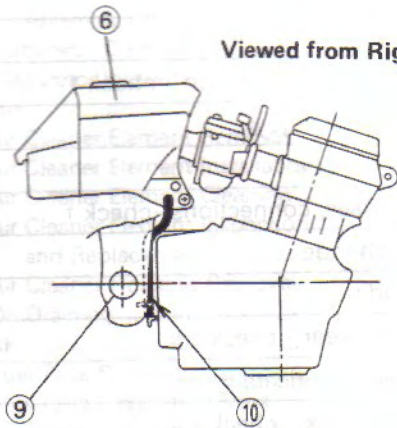

1. Air Cleaner Duct (#2)
2. Fuel Tank Bracket
3. Carburetor Vent Hose
4. Rear Frame
5. Air Cleaner Duct (#1)
6. Air Cleaner Housing
7. Route vacuum hose beneath coasting enricher body.
8. Coasting Enricher Body
9. Swing Arm Pivot
10. Route drain hose between swing arm pivot and crankcase.
11. Rubber Band
12. Battery
13. Swing Arm
14. Battery Vent Hose
15. Coolant Reservoir Tank Vent Hose
16. Fuel Tank Breather Hose

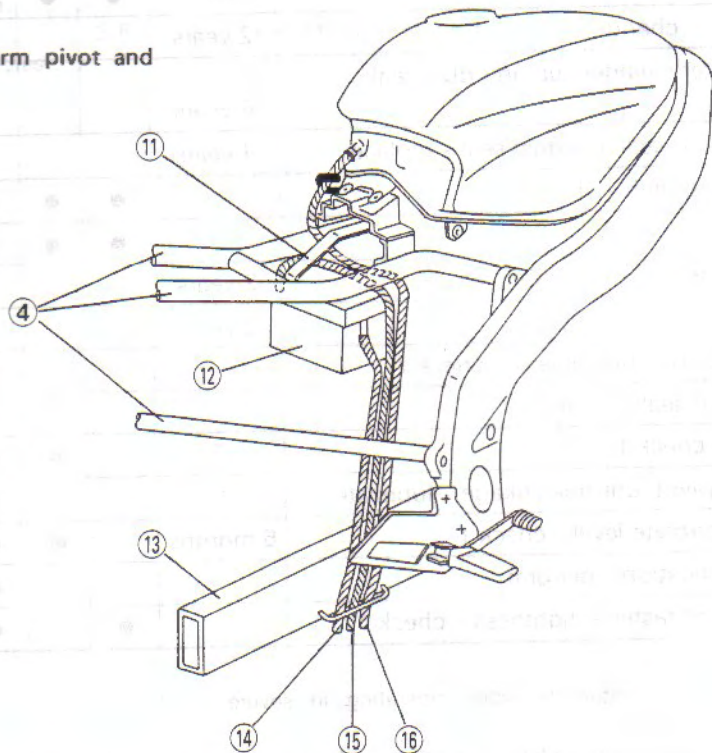

1-12 GENERAL INFORMATION

Periodic Maintenance Chart

The scheduled maintenance must be done in accordance with this chart to keep the motorcycle in good running condition. The initial maintenance is vitally important and must not be neglected.

OPERATION	FREQUENCY	*ODOMETER READING							
		Whichever comes first	1 000 km (600 mile)	6 000 km (4 000 mile)	12 000 km (7 500 mile)	18 000 km (12 000 mile)	24 000 km (15 000 mile)	30 000 km (20 000 mile)	36 000 km (24 000 mile)
Spark plug - clean and gap †		•	•	•	•	•	•	•	•
Valve clearance - check †			•		•		•		•
Air cleaner element - clean † #			•		•		•		•
Throttle grip play - check †		•		•		•		•	
Idle speed - check †		•		•		•		•	
Carburetor synchronization - check †			•		•		•		•
Engine oil - change #	6 months	•	•	•	•	•	•	•	•
Oil filter - replace		•		•		•		•	
Radiator hoses, connections - check †		•							
Coolant - change	2 years					•			
Clutch - adjust		•	•	•	•	•	•	•	•
Drive chain wear - check † #			•	•	•	•	•	•	•
Drive chain - lubricate #	600 km								
Drive chain slack - check † #	1 000 km								
Brake lining or pad wear - check † #			•	•	•	•	•	•	•
Brake fluid level - check †	month	•	•	•	•	•	•	•	•
Brake fluid - change	2 years					•			
Brake master cylinder cup and dust seal - replace	4 years								
Caliper piston seal and dust seal - replace	4 years								
Brake light switch - check †		•	•	•	•	•	•	•	•
Steering - check †		•	•	•	•	•	•	•	•
Steering stem bearing - lubricate	2 years					•			
Front fork oil - change	2 years					•			
Rear shock absorber oil leak - check †			•		•		•		•
Front fork oil leak - check †			•		•		•		•
Tire wear - check †			•	•	•	•	•	•	•
Swingarm pivot, uni-trak linkage - lubricate			•		•		•		•
Battery electrolyte level - check †	6 months		•	•	•	•	•	•	•
General lubrication - perform				•		•		•	
Nut, bolt, and fastener tightness - check †		•	•		•		•		•

: Service more frequently when operating in severe conditions, dusty, wet, muddy, high speed, or frequent starting/stopping.

* : For higher odometer readings, repeat at the frequency interval established here.

† : Replace, add, adjust, clean, or torque if necessary.

Fuel System

Table of Contents

Exploded View.....	2-2	Carburetor Separation.....*	
Specifications.....	2-4	Carburetor Installation.....*	
Special Tools.....	2-4	Carburetor Disassembly and	
Throttle Grip and Cables.....	2-5	Assembly Notes.....*	
Throttle Grip Play Inspection.....*		Carburetor Cleaning.....*	
Throttle Cable Adjustment.....	2-5	Carburetor Inspection.....*	
Throttle Cable Lubrication.....*		Air Cleaner.....	2-6
Throttle Cable Inspection.....*		Air Cleaner Element Removal.....	2-6
Choke Cable.....	2-5	Air Cleaner Element Installation Notes.....	2-7
Choke Cable Free Play Inspection.....	2-5	Air Cleaner Element Cleaning.....*	
Choke Cable Adjustment.....	2-5	Air Cleaner Element Inspection	
Choke Cable Lubrication.....*		and Replacement.....*	
Choke Cable Inspection.....*		Air Cleaner Housing Removal.....	2-7
Carburetors.....	2-6	Oil Draining.....	2-7
Idle Speed Inspection.....*		Fuel Tank.....	2-8
Idle Speed Adjustment.....	2-6	Fuel Tank Removal.....	2-8
Carburetor Synchronization Inspection.....	2-6	Fuel Tank Installation Note.....	2-8
Carburetor Synchronization.....*		Fuel Tank and Tap Cleaning.....*	
Fuel Level Inspection.....*		Fuel Tap Inspection.....*	
Fuel Level Adjustment.....*		Fuel Tank and Cap Inspection.....*	
Fuel System Cleanliness Inspection.....*			
Carburetor Assembly Removal.....	2-6		
Carburetor Assembly Installation Notes.....*			

* : Refer to Base Manual

Quick Reference

2-2 FUEL SYSTEM

Exploded View

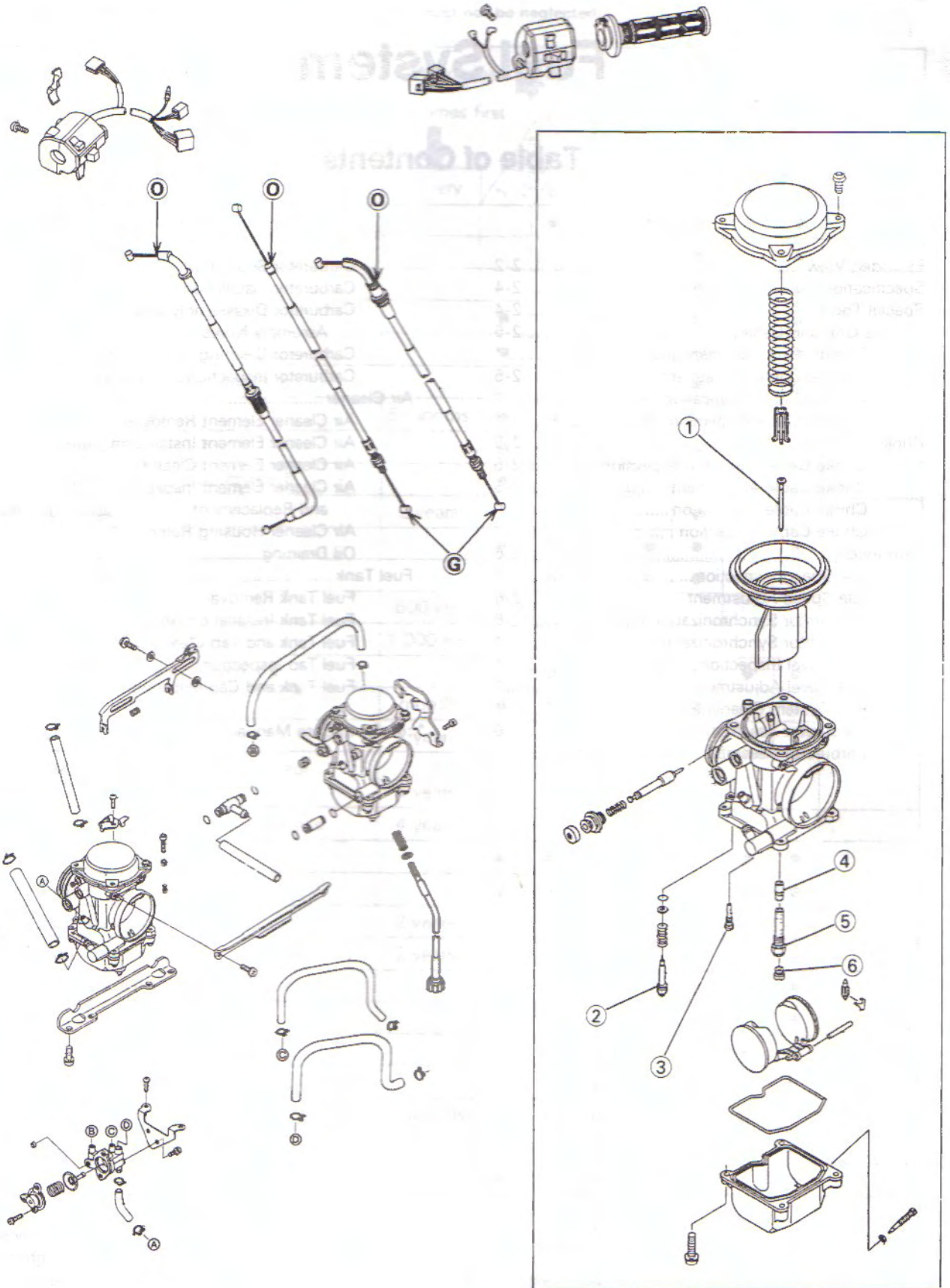

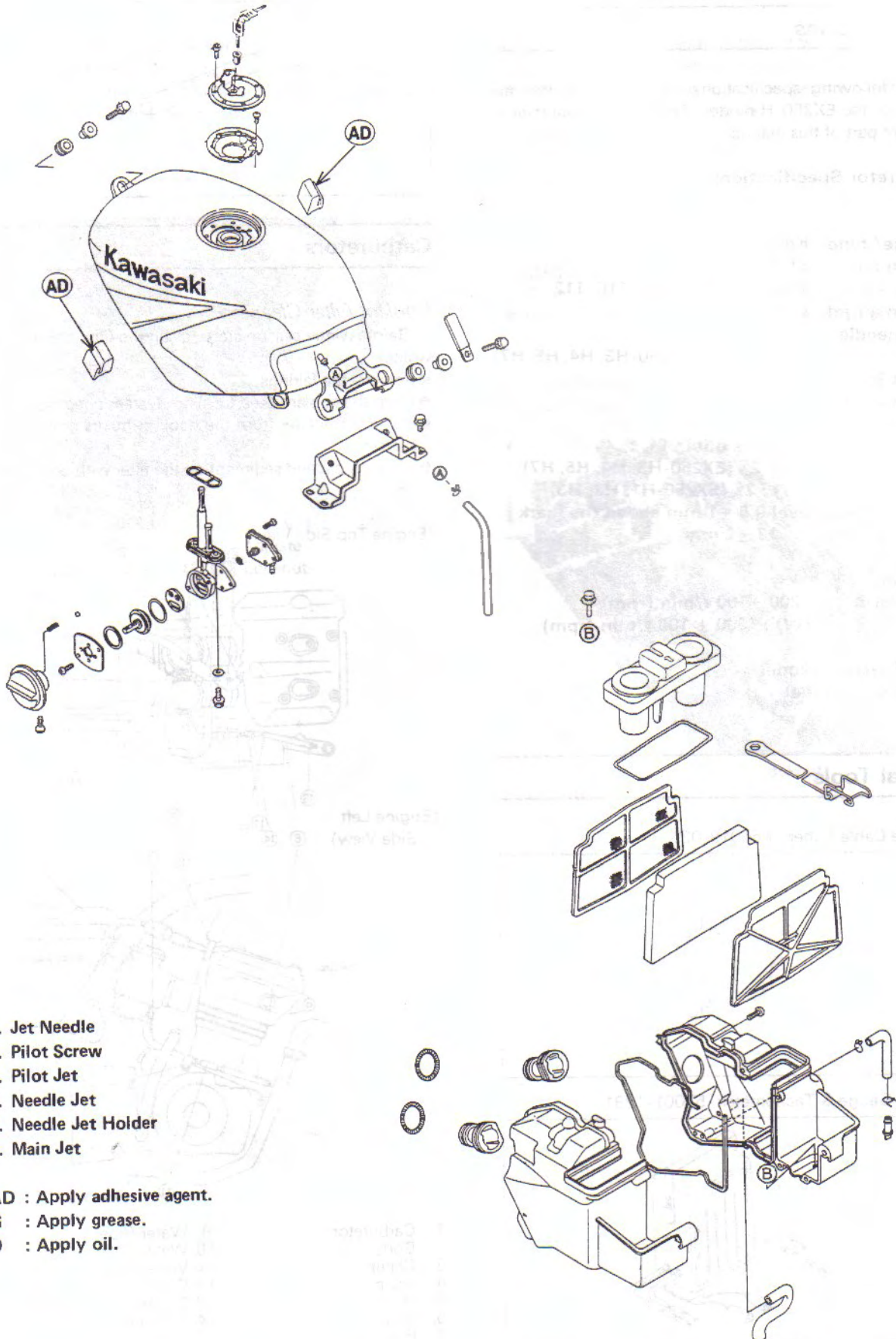

1. Jet Needle
2. Pilot Screw
3. Pilot Jet
4. Needle Jet
5. Needle Jet Holder
6. Main Jet

AD : Apply adhesive agent.
 G : Apply grease.
 O : Apply oil.

2-4 FUEL SYSTEM

Fuel System

Specifications

The following specifications are only those that are unique to the EX250-H model. For all other data refer to the front part of this manual.

Carburetor Specifications

Make/ type	Keihin, CVK30
Main jet	#108, Optional #102, 105, 110, 112
Main air jet	#100
Jet needle	N16L, (Ar): N16M (EX250-H3, H4, H5, H7)
Pilot jet	#38
Pilot air jet	#90
Starter jet	#52
Pilot screw	1 1/4 turns out (Ar): 2 1/4 (EX250-H3, H4, H5, H7) (W): 2 1/4 (EX250-H1, H2, H3)
Service Fuel Level	0.5 ± 1 mm above the mark
Float height	17 ± 2 mm

Idle Speed

Standard:	1200 ± 100 r/min (rpm)
(W):	1300 ± 100 r/min (rpm)

(Ar): Austrian Model

(W): Swiss Model

Special Tools

Pressure Cable Luber: K56019-021

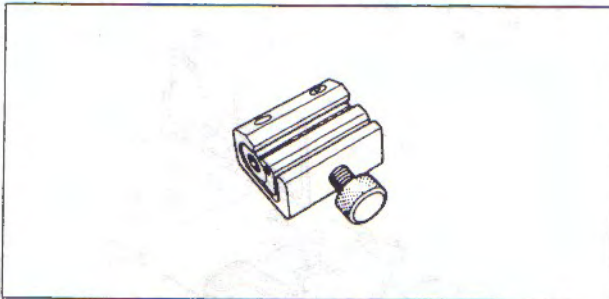

Vacuum Gauge & Tachometer: 57001-1291

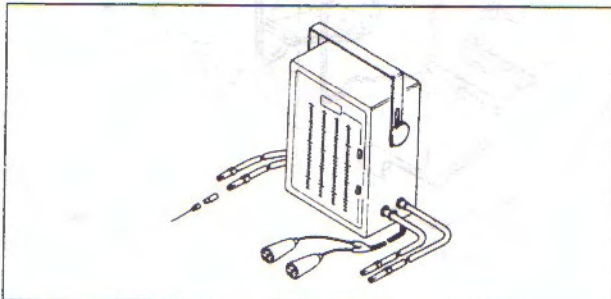

Fuel Level Gauge: 57001-1017

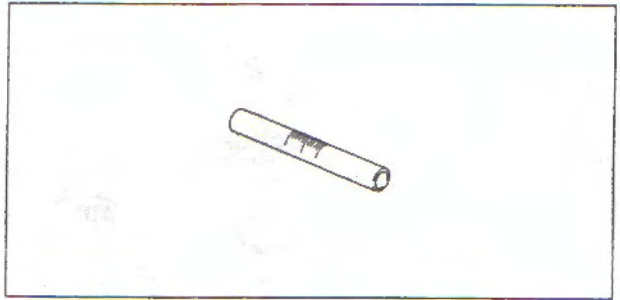

Carburetors

Coolant Filter Cleaning

Before winter season starts, clean the filter of carburetor system.

- Remove the fairings.
- Drain the coolant (see Cooling System chapter).
- Remove the filter from the cooling hoses of carburetor system.
- Blow off dirt and sediment on the filter with compressed air.

(Engine Top Side View)

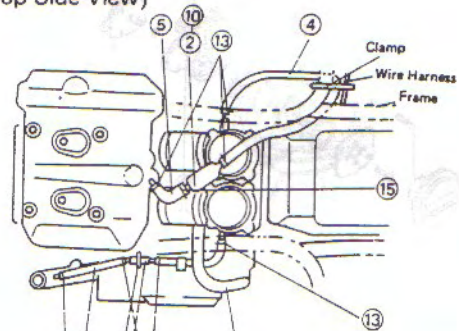

(Engine Left Side View)

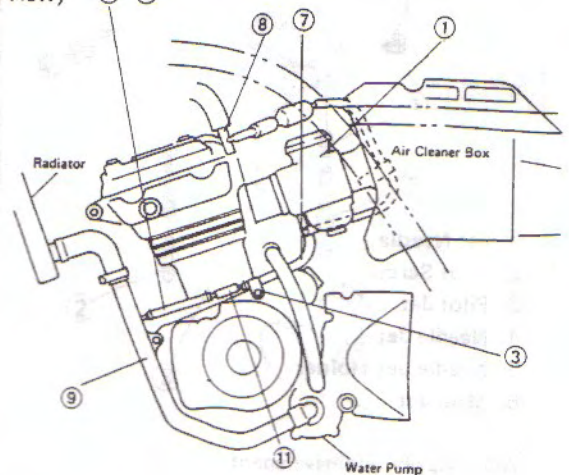

- | | |
|---------------|------------------|
| 1. Carburetor | 9. Water Pipe |
| 2. Body | 10. Water Filter |
| 3. Clamp | 11. Valve Assy |
| 4. Hose | 12. Clamp |
| 5. Hose | 13. Clamp |
| 6. Hose | 14. Damper |
| 7. Hose | 15. Clamp |
| 8. Water Pipe | |

Throttle Grip and Cables

Throttle Cable Adjustment

Refer to the Base Manual, noting the following.

- Remove the following to adjust the throttle cables using the adjusters at the lower ends of cables.

Seat
Side Covers
Fuel Tank

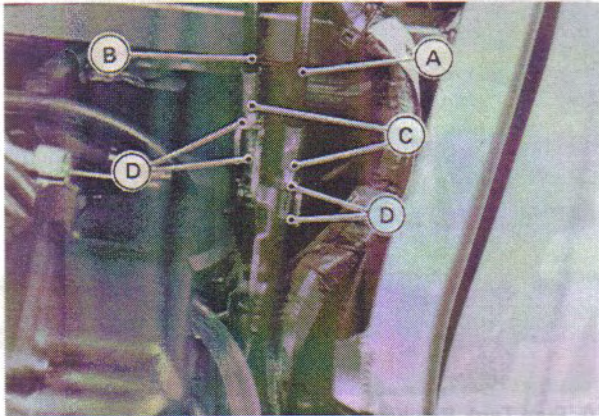

A. Accelerator Cable
B. Decelerator Cable
C. Adjusters
D. Locknuts

Choke Cable

Choke Cable Free Play Inspection

Refer to the Base Manual, noting the following.

- Remove the following to check the movement of the carburetor starter plunger lever.

Seat
Side Covers
Fuel Tank

Choke Cable Adjustment

Refer to the Base Manual, noting the following.

- Remove the following to adjust the choke cable using the adjuster at the middle of the cable.

Seat
Side Covers
Fuel Tank

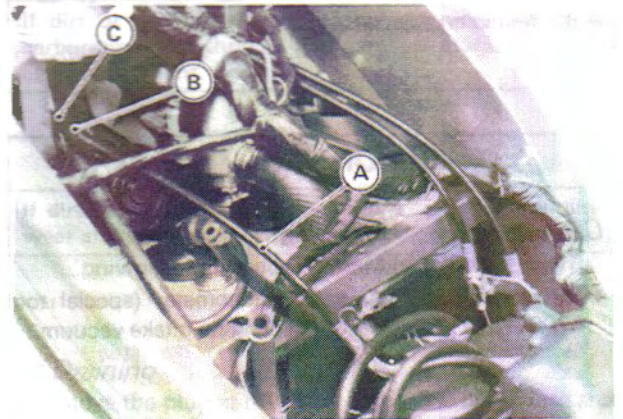

A. Choke Cable
B. Adjuster
C. Locknut

2-6 FUEL SYSTEM

Carburetors

Idle Speed Adjustment

Refer to the Base Manual, noting the following.

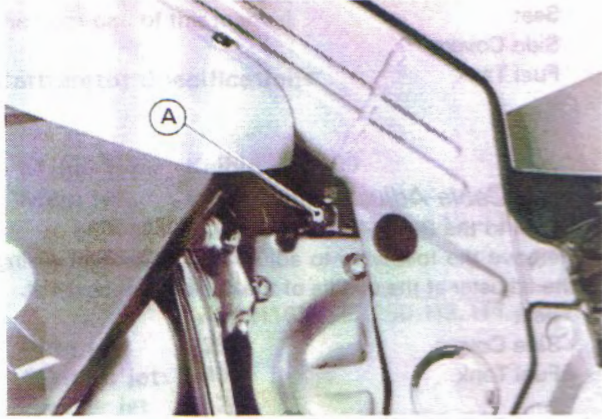

A. Idle Adjusting Screw

Carburetor Synchronization Inspection

Refer to the Base Manual, noting the following.

- Use the vacuum gauge & tachometer (special tool: 57001-1291) to measure the engine intake vacuum.

Carburetor Assembly Removal

Refer to the Base Manual, noting the following.

- Remove the following to remove the carburetor assembly.
 - Fuel Tank
 - Lower Fairings
 - Battery
 - Rear Fender Front Mounting Bolts

Air Cleaner

Air Cleaner Element Removal

- Remove:
 - Seat
 - Side Covers
 - Fuel Tank Bracket Bolts
 - Rubber Band (unhook)

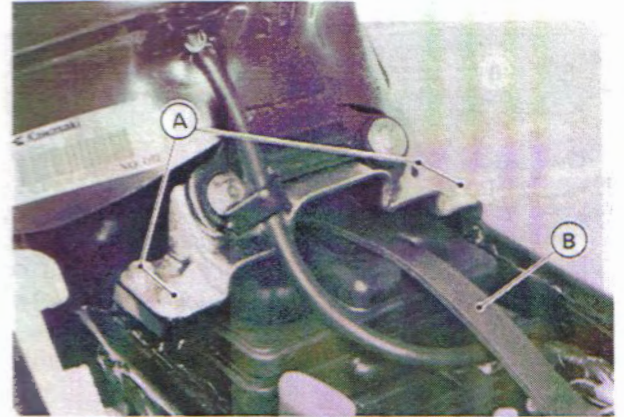

A. Fuel Tank Bracket Bolts B. Rubber Band

Air Cleaner Housing Cap
Air Cleaner Element

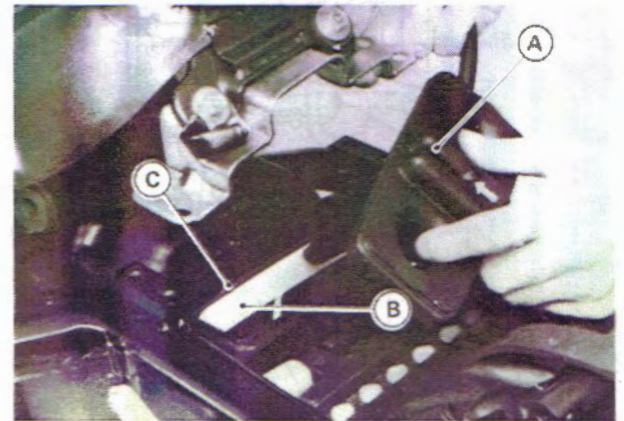

A. Housing Cap C. Element
B. Element Holder

- Push a clean, lint-free towel into the air cleaner housing to keep dirt or other foreign material from entering.

⚠ WARNING

If dirt or dust is allowed to pass through into the carburetors, the throttle may become stuck, possibly causing accident.

CAUTION

If dirt gets through into the engine, excessive engine wear and possibly engine damage will occur.

Air Cleaner Element Installation Notes

- Set the element holder so that the holder lower end comes to the front side of the housing bottom edge.

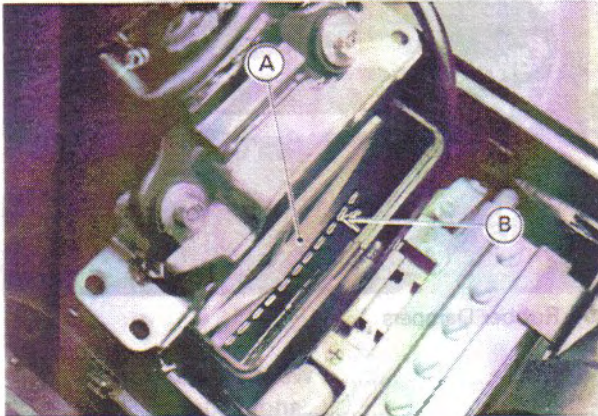

A. Element Holder B. Housing Bottom Edge

- Install the air cleaner housing cap with the arrow pointing forward.

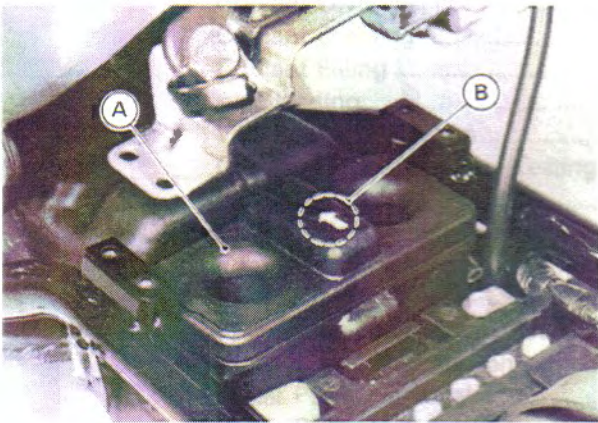

A. Housing Cap B. Arrow

Air Cleaner Housing Removal

- Remove the following.
 - Seat
 - Side Covers
 - Fuel Tank
 - Rear Fender
 - Rear Frame
 - Air Cleaner Housing

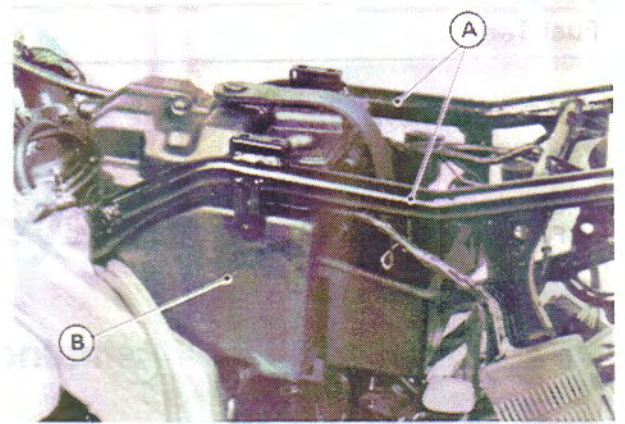

A. Rear Frame B. Air Cleaner Housing

- Cover the carburetor intakes with a clean, lint-free towel to keep dirt or other foreign material from entering.

⚠ WARNING

If dirt or dust is allowed to pass through into the carburetors, the throttle may become stuck, possibly causing accident.

CAUTION

If dirt gets through into the engine, excessive engine wear and possibly engine damage will occur.

Oil Draining

- Remove the plug at the lower end of the drain hose and drain water or oil accumulates in the air cleaner housing.

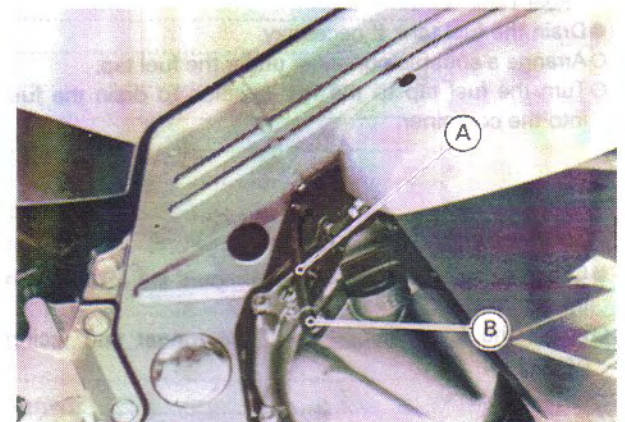

A. Drain Hose B. Plug

- Be sure to install the plug firmly, or the air is drawn through it.

⚠ WARNING

Be sure to install the plug in the drain hose after draining. Oil on tires will make them slippery and can cause an accident and injury.

2-8 FUEL SYSTEM

Fuel Tank

Fuel Tank Removal

- Remove the following.
 - Seat
 - Side Covers
 - Fuel Tank Mounting Bolts

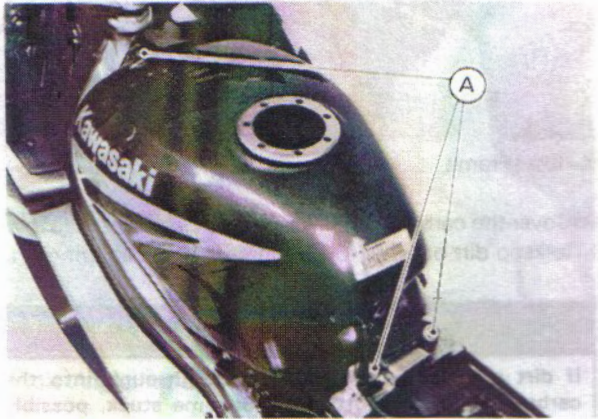

A. Fuel Tank Mounting Bolts

- Turn the fuel tap to the ON or RES position.
 - Hoses (disconnect)

⚠ WARNING

Gasoline is extremely flammable and can be explosive under certain conditions. Turn the ignition switch OFF. Do not smoke. Make sure the area is well ventilated and free from any source of flame or sparks; this includes any appliance with a pilot light.

Fuel Tank

- Drain the fuel tank if necessary.
- Arrange a suitable container under the fuel tap.
- Turn the fuel tap to the PRI position to drain the fuel into the container.

Fuel Tank Installation Note

- Check to see that the rubber dampers are installed on the fuel tank.
- Install the front damper with the longer end facing down.



A. Rubber Dampers

Cooling System

Table of Contents

Exploded View	3-2
Specifications	3-3
Sealant	3-3
Cooling System	*
Coolant	*
Coolant Deterioration	*
Coolant Level Inspection	*
Coolant Draining	*
Coolant Filling	*
Air Bleeding	*
Visual Leak Inspection	*
Cooling System Pressure Testing	*
Flushing	*
Disassembly and Assembly Precautions	*
Water Pump	*
Pump Cover Removal	*
Pump Cover Installation Note	*
Pump Impeller Inspection	*
Water Pump Removal	*
Water Pump Installation Notes	*
Radiator, Radiator Fan	3-4
Radiator, Radiator Fan Removal	3-4
Radiator Inspection	*
Radiator Cleaning	*
Radiator Cap Inspection	*
Radiator Hose, Reservoir Tank Tube Inspection	*
Radiator Hose, Pipes, Reservoir Tank Tube Installation Notes	*
Thermostat	3-4
Thermostat Removal	3-4
Thermostat Installation Note	3-4
Thermostat Inspection	*
Thermostatic Fan Switch, Water Temperature Sensor	*
Water Temperature Sensor Removal	*
Fan Switch Removal	*
Installation Note	*
Inspection	*

* : Refer to Base Manual

3-2 COOLING SYSTEM

Exploded View

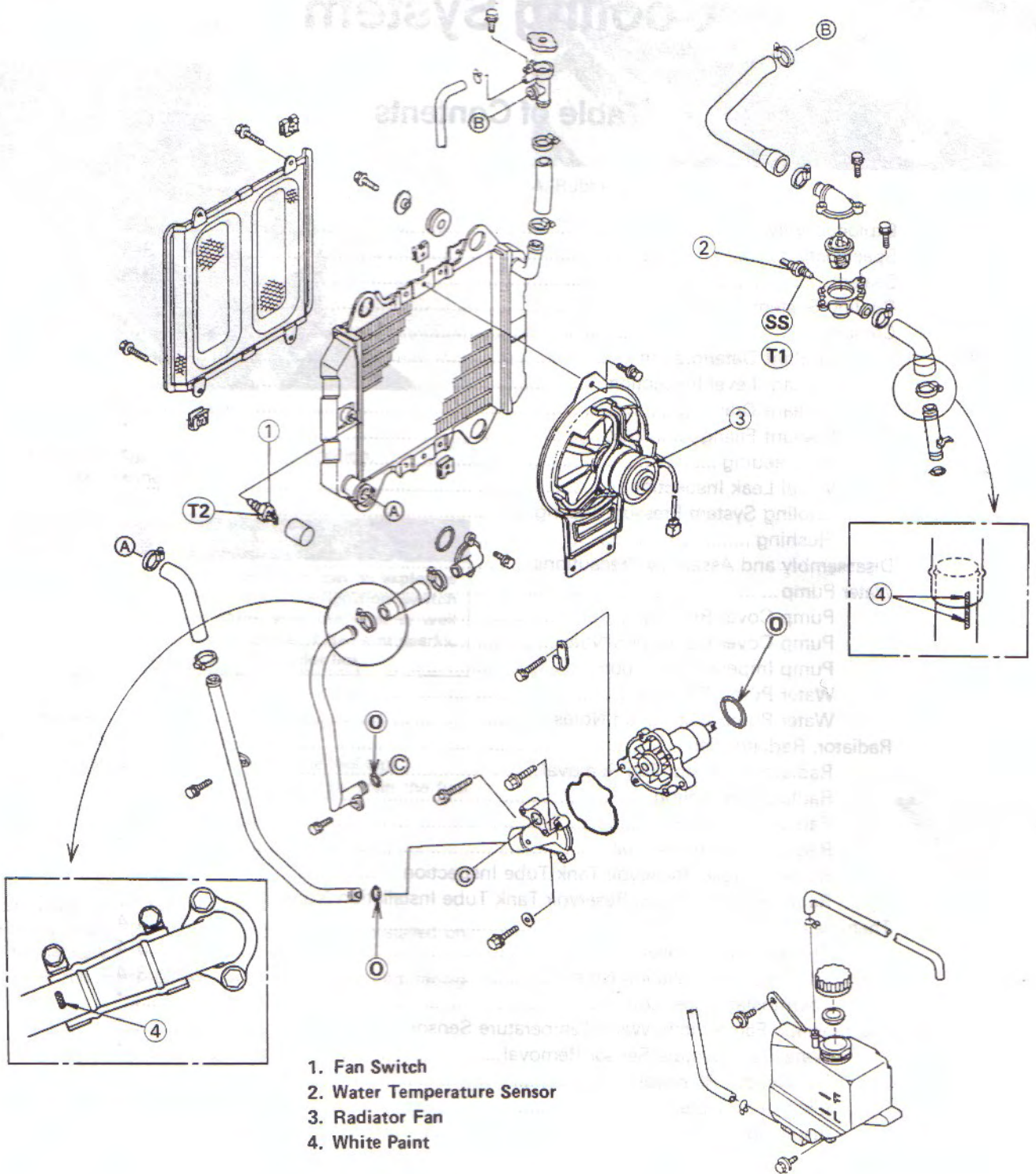

1. Fan Switch
2. Water Temperature Sensor
3. Radiator Fan
4. White Paint

O : Apply oil.
SS : Apply silicone sealant.

T1 : 7.8 N-m (0.80 kg-m, 69 in-lb)
T2 : 18 N-m (1.8 kg-m, 13.0 ft-lb)

Specifications

Item	Standard
Coolant: Type Mixed ratio Freezing point Total amount	Permanent type of antifreeze (soft water and ethylene glycol plus corrosion and rust inhibitor chemicals for aluminum engines and radiators) Soft water 50%, coolant 50% -35°C (-31°F) 1.0 L
Radiator: Radiator cap relief pressure	93 ~ 123 kPa (0.95 ~ 1.25 kg/cm ² , 14 ~ 18 psi)
Thermostat: Valve opening temperature Valve full opening lift	80.5 ~ 83.5°C (177 ~ 182°F) More than 6 mm @95°C (203°F)

Sealant

Kawasaki Bond (Silicone Sealant): 56019-120

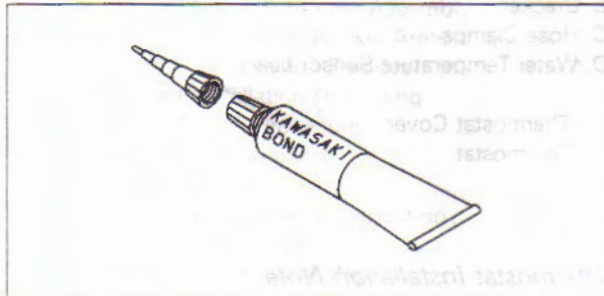

3-4 COOLING SYSTEM

Radiator, Radiator Fan

Radiator, Radiator Fan Removal

Refer to the Base Manual, noting the following.

- There is no ground lead on the radiator fan mounting bolt.

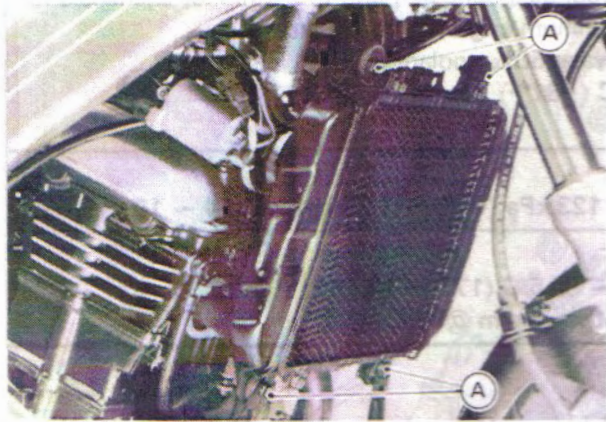

A. Radiator Mounting Bolts

Thermostat

Thermostat Removal

- Remove the following.
 - Coolant (drain)
 - Fuel Tank
 - Thermostat Housing Bracket Bolts
 - Hose Clamps (loosen)
 - Water Temperature Sensor Lead
 - Thermostat Housing

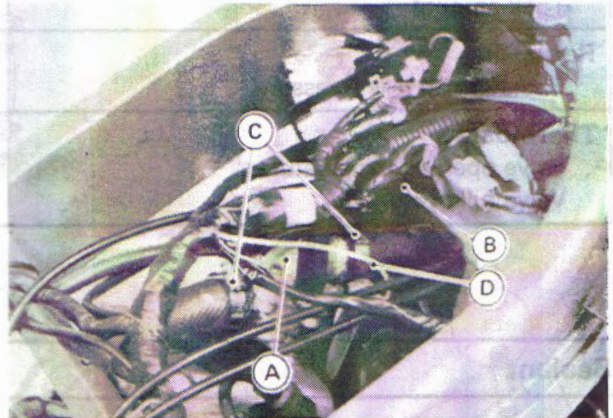

- A. Thermostat Housing
- B. Bracket
- C. Hose Clamps
- D. Water Temperature Sensor Lead

Thermostat Cover
Thermostat

Thermostat Installation Note

- Be sure to install the ground lead on the thermostat housing mounting bolt.

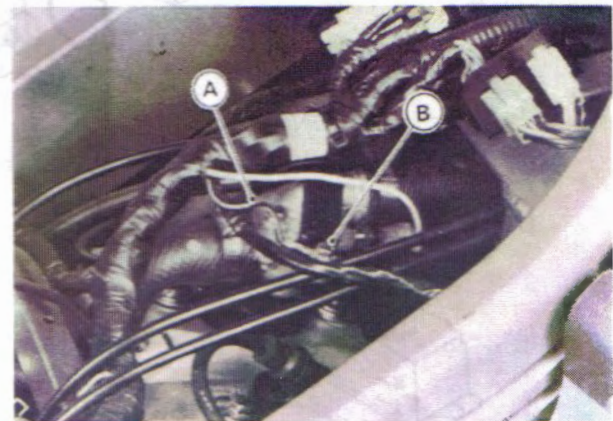

A. Ground Lead

B. Mounting Bolt

Engine Top End

Table of Contents

4

Exploded View.....	4-2	Cylinder Head Warp.....*	
Specifications.....	4-4	Cylinder Head Cleaning.....*	
Special Tools.....	4-5	Valves*	
Sealant.....	4-6	Valve Clearance Inspection.....*	
Cylinder Head Cover.....	4-7	Valve Clearance Adjustment.....*	
Cylinder Head Cover Removal.....*		Valve Seat Inspection.....*	
Cylinder Head Cover		Valve Seat Repair.....*	
Installation Notes.....	4-7	Measuring Valve-to-Guide Clearance	
Camshaft Chain Tensioner.....*		(Wobble Method).....*	
Chain Tensioner Removal.....*		Cylinders, Pistons*	
Chain Tensioner Installation.....*		Cylinder Removal.....*	
Camshaft Chain Tensioner Disassembly.....*		Cylinder Installation Notes.....*	
Camshaft Chain Tensioner Assembly.....*		Piston Removal.....*	
Camshafts, Camshaft Chain, Rocker Arms.....*		Piston Installation Note.....*	
Camshaft, Rocker Arm Removal.....*		Piston Ring, Piston Ring Groove Wear.....*	
Camshaft Installation (Including		Piston Ring End Gap.....*	
Chain Timing Procedure).....*		Cylinder Inside Diameter.....*	
Camshaft and Sprocket		Piston Diameter.....*	
Assembly Notes.....*		Boring, Honing.....*	
Camshaft Oil Clearance Inspection.....*		Carburetor Holders*	
Camshaft Chain Wear.....*		Carburetor Holder Installation.....*	
Camshaft Chain Guide Wear.....*		Mufflers	4-7
Cylinder Head.....	4-7	Muffler Removal.....	4-7
Compression Measurement.....	4-7	Muffler Installation.....	4-8
Cylinder Head Removal.....*		Exhaust System Inspection.....*	
Cylinder Head Installation Notes.....*			
Cylinder Head Disassembly and			
Assembly (Valve Mechanism			
Removal and Installation).....*			

* : Refer to Base Manual

Quick Reference

4-2 ENGINE TOP END

Exploded View

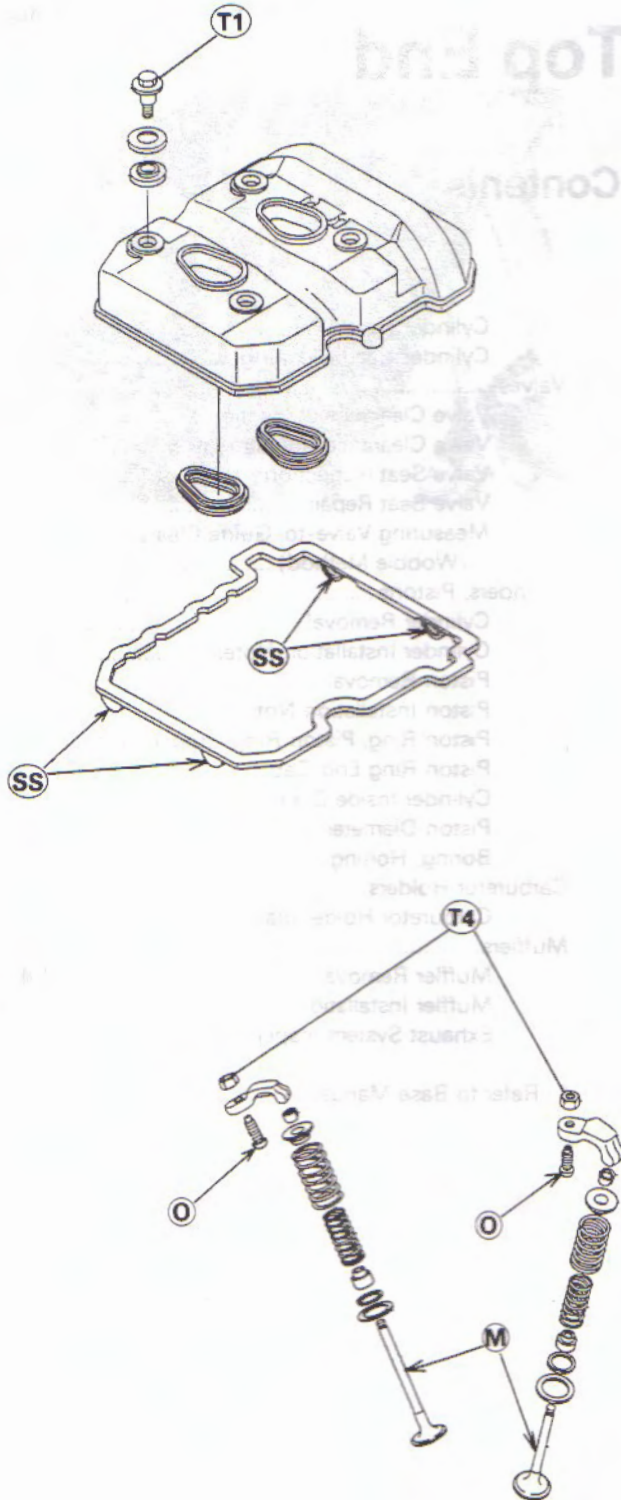

Thermostat

Thermostat
 Thermostat
 Thermostat

Engine Top End

Table of Contents

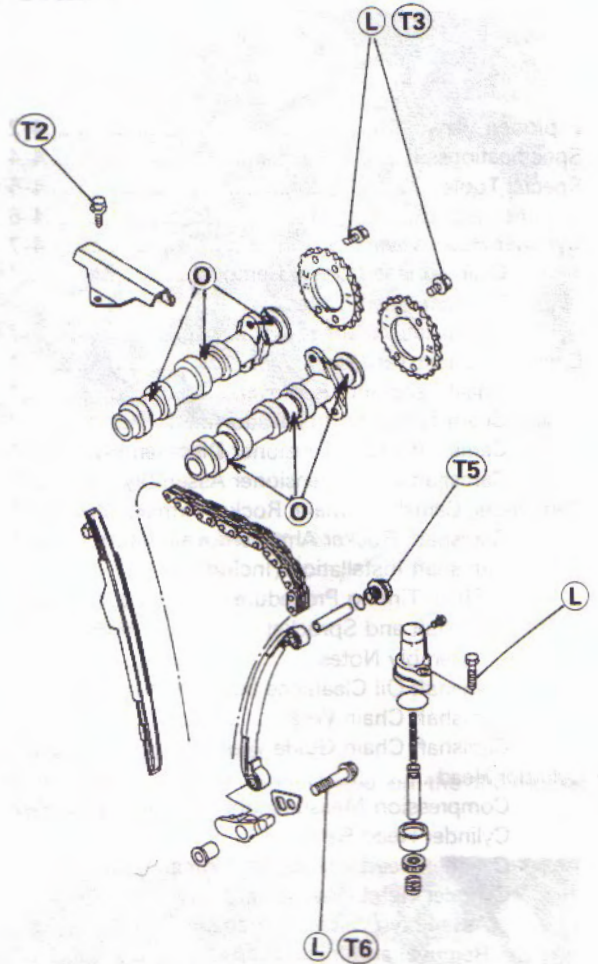

1. Nut
2. Washer
3. Bolt

L : Apply non-permanent locking agent.
 M : Apply molybdenum disulfide grease.
 O : Apply oil.
 S : Follow the specified tightening sequence.
 SS : Apply silicone sealant.

- T1: 9.8 N-m (1.0 kg-m, 87 in-lb)
 T2: 12 N-m (1.2 kg-m, 104 in-lb)
 T3: 15 N-m (1.5 kg-m, 11.0 ft-lb)
 T4: 20 N-m (2.0 kg-m, 14.5 ft-lb)
 T5: 25 N-m (2.5 kg-m, 18.0 ft-lb)
 T6: 27 N-m (2.8 kg-m, 20 ft-lb)

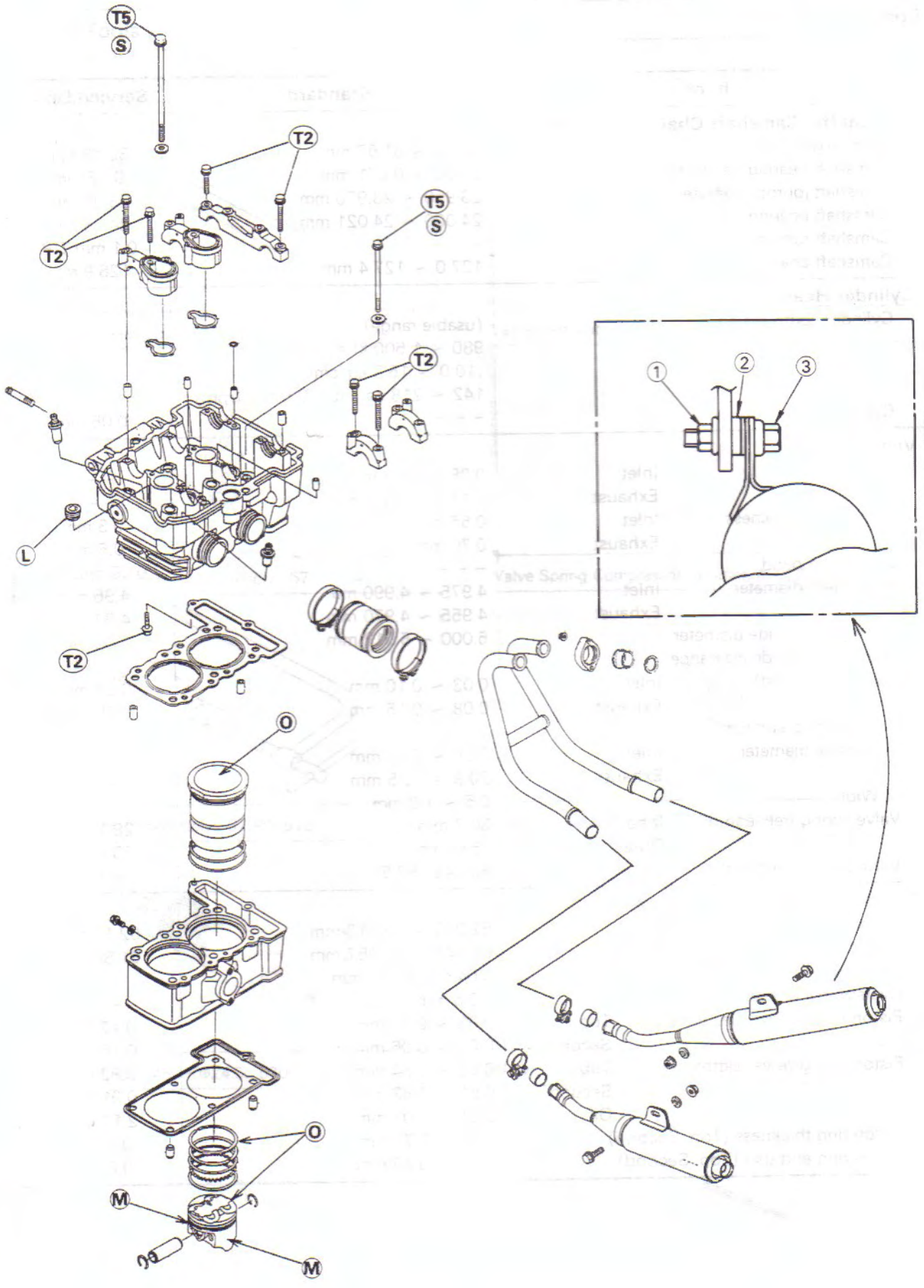

4-4 ENGINE TOP END

Specifications

Item	Standard	Service Limit	
Camshafts, Camshaft Chain, Rocker Arms:			
Cam height	30.53 ~ 31.67 mm	30.43 mm	
Camshaft bearing oil clearance	0.030 ~ 0.071 mm	0.16 mm	
Camshaft journal diameter	23.950 ~ 23.970 mm	23.92 mm	
Camshaft bearing inside diameter	24.000 ~ 24.021 mm	24.08 mm	
Camshaft runout	---	0.1 mm TIR	
Camshaft chain 20-link length	127.0 ~ 127.4 mm	128.9 mm	
Cylinder Head:			
Cylinder compression	(usable range) 980 ~ 1 500 kPa (10.0 ~ 15.3 kg/cm ² , 142 ~ 218 psi) @470 r/min (rpm)	---	
Cylinder head warp	---	0.05 mm	
Valves:			
Valve clearance:	Inlet	0.08 ~ 0.13 mm	---
	Exhaust	0.11 ~ 0.16 mm	---
Valve head thickness:	Inlet	0.65 mm	0.3 mm
	Exhaust	0.70 mm	0.5 mm
Valve stem bend	---	---	0.05 mm TIR
Valve stem diameter:	Inlet	4.975 ~ 4.990 mm	4.96 mm
	Exhaust	4.955 ~ 4.970 mm	4.94 mm
Valve guide inside diameter		5.000 ~ 5.012 mm	5.08 mm
Valve/valve guide clearance (wobble method):	Inlet	0.03 ~ 0.10 mm	0.24 mm
	Exhaust	0.08 ~ 0.15 mm	0.29 mm
Valve seating surface:			
Outside diameter:	Inlet	22.9 ~ 23.1 mm	---
	Exhaust	20.3 ~ 20.5 mm	---
Width		0.5 ~ 1.0 mm	---
Valve spring free length:	Inner	30.7 mm	29.1 mm
	Outer	35.0 mm	33.4 mm
Valve seat cutting angle		32°, 45°, 67.5°	---
Cylinders, Pistons:			
Cylinder inside diameter		62.000 ~ 62.012 mm	62.10 mm
Piston diameter		61.942 ~ 61.957 mm	61.80 mm
Piston/cylinder clearance		0.043 ~ 0.070 mm	---
Oversize pistons and rings		+0.5 mm	---
Piston ring/groove clearance:	Top	0.03 ~ 0.07 mm	0.17 mm
	Second	0.02 ~ 0.06 mm	0.16 mm
Piston ring groove width:	Top	0.82 ~ 0.84 mm	0.92 mm
	Second	0.81 ~ 0.83 mm	0.91 mm
	Oil	2.01 ~ 2.03 mm	2.11 mm
Piston ring thickness (Top, Second)		0.77 ~ 0.79 mm	0.7 mm
Piston ring end gap (Top, Second)		0.30 ~ 0.45 mm	0.8 mm

Special Tools

Piston Base, $\phi 2.3$: 57001-149

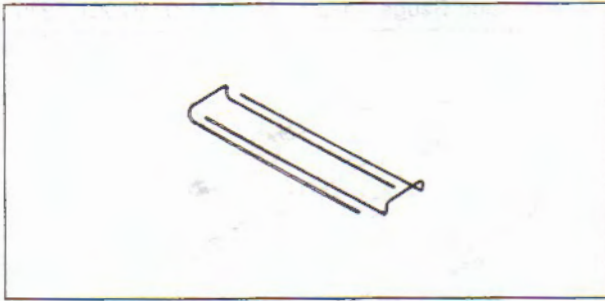

Compression Gauge: 57001-221



Valve Spring Compressor Assembly: 57001-241

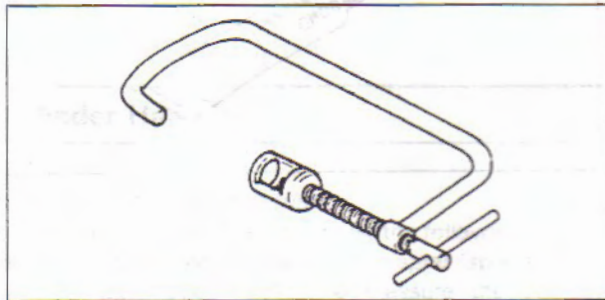

Piston Pin Puller Assembly: 57001-910

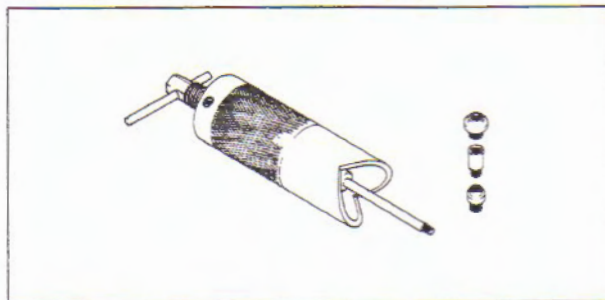

Valve Seat Cutter, 45° - $\phi 24.5$: 57001-1113



Valve Seat Cutter, 32° - $\phi 25$: 57001-1118



Valve Seat Cutter Holder Bar: 57001-1128

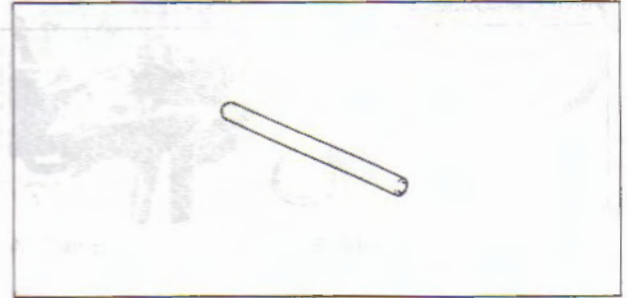

Valve Spring Compressor Adapter, $\phi 22$: 57001-1202

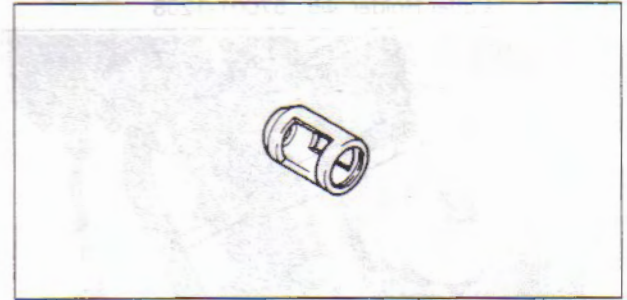

Valve Guide Arbor, $\phi 5$: 57001-1203



Valve Guide Reamer, $\phi 5$: 57001-1204

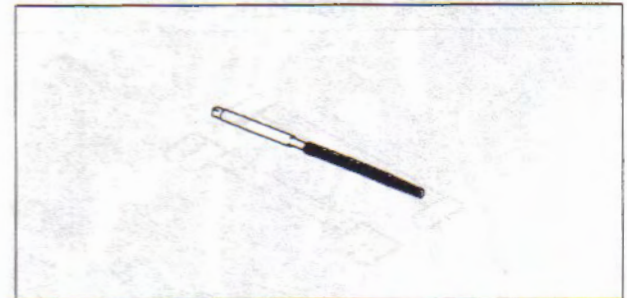

4-6 ENGINE TOP END

Special Tools

Valve Seat Cutter, 32° - $\phi 22$: 57001-1206



Compression Gauge Adapter, M10 X 1.0: 57001-1317

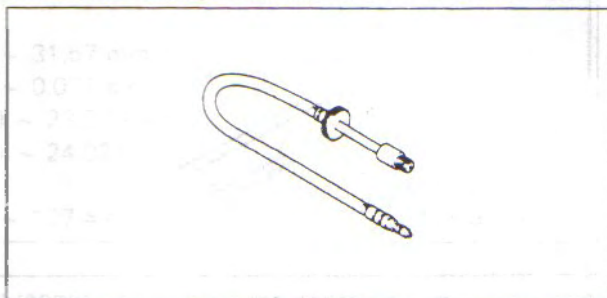

Valve Seat Cutter, 67.5° - $\phi 22$: 57001-1207



Sealant

Kawasaki Bond (Silicone Sealant): 56019-120



Valve Seat Cutter Holder, $\phi 5$: 57001-1208

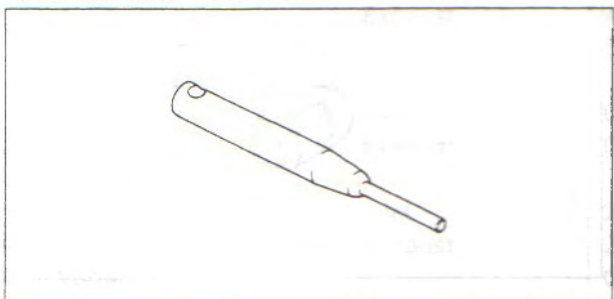

Valve Adjuster: 57001-1220

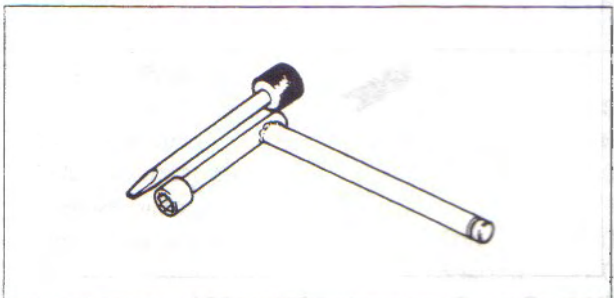

Thickness Gauge Set: 57001-1221

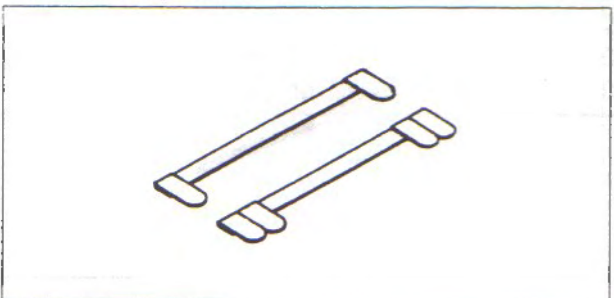

Cylinder Head Cover

Cylinder Head Cover Installation Notes

Refer to the Base Manual, noting the following.

- Apply a silicone sealant to the following.

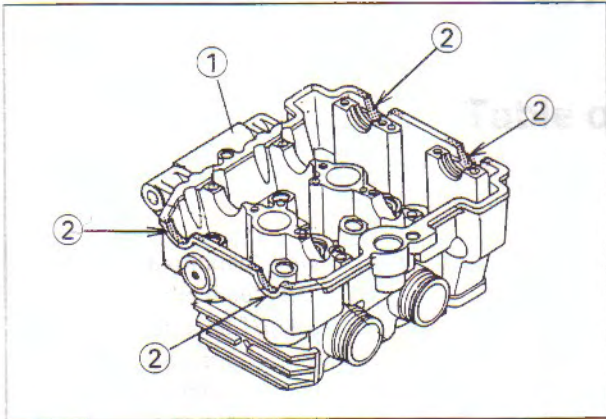

1. Cylinder Head
2. Silicone Sealant Applied Area

Cylinder Head

Compression Measurement

Refer to the Base Manual, noting the following.

- Use the compression gauge and adapter (special tools: 57001-221, 57001-1317) to measure the cylinder compression.

Mufflers

Muffler Removal

- Remove the following.
 - Muffler Clamps (loosen)
 - Muffler Mounting Bolts and Nuts
 - Mufflers

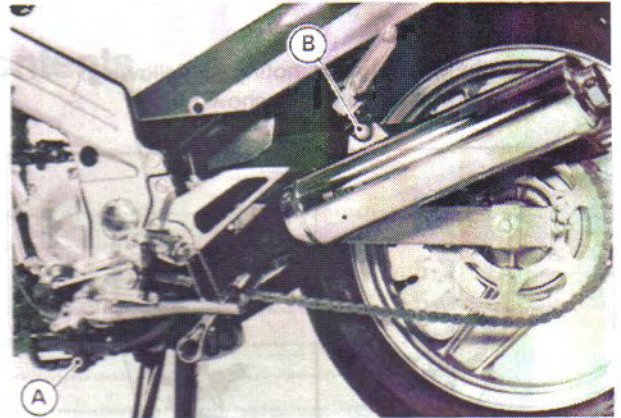

- A. Clamp
- B. Mounting Bolt

Lower Fairings
Fairing Mounting Brackets

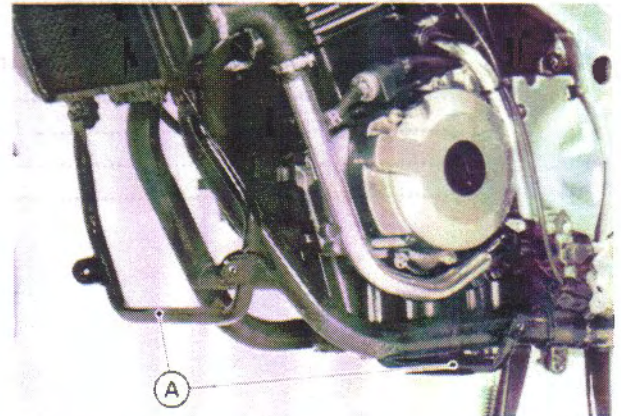

- A. Fairing Mounting Brackets

Exhaust Pipe Holders

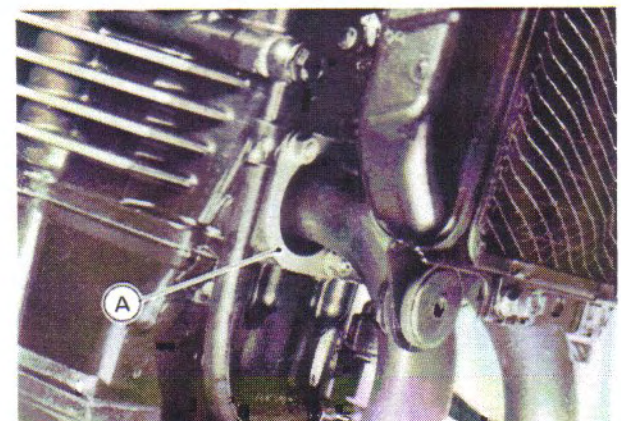

- A. Exhaust Pipe Holder

4-8 ENGINE TOP END

Split Keepers
Exhaust Pipes

CAUTION

Be careful not to touch the radiator fins during work.
The fins are easily deformed.

Muffler Installation

Refer to the Base Manual, noting the following.

- Position the muffler clamps as shown.

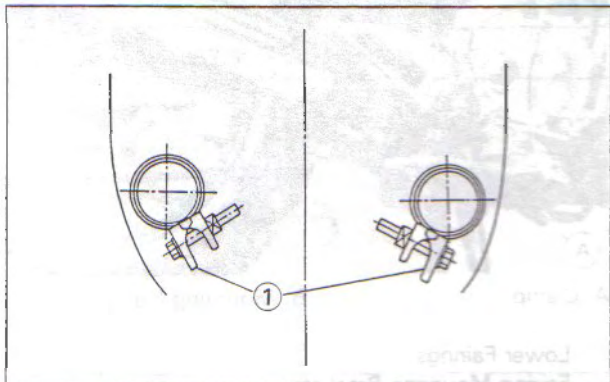

1. Muffler Clamps



Clutch

Table of Contents

Exploded View	5-2
Specifications	5-3
Special Tools	5-3
Sealant	5-3
Clutch	5-4
Clutch Adjustment Check	*
Clutch Adjustment	*
Clutch Cover Removal	*
Clutch Cover Installation Notes	5-4
Clutch Release Lever (Shaft) Removal	*
Clutch Release Lever (Shaft) Installation Notes	*
Clutch Removal	5-4
Clutch Installation Notes	*
Friction Plate Wear, Damage Inspection	*
Friction or Steel Plate Warp Inspection	*
Clutch Spring Free Length Measurement	*
Clutch Housing Finger Inspection	*
Clutch Hub Spline Inspection	*

* : Refer to Base Manual

Quick Reference

5-2 CLUTCH

Exploded View

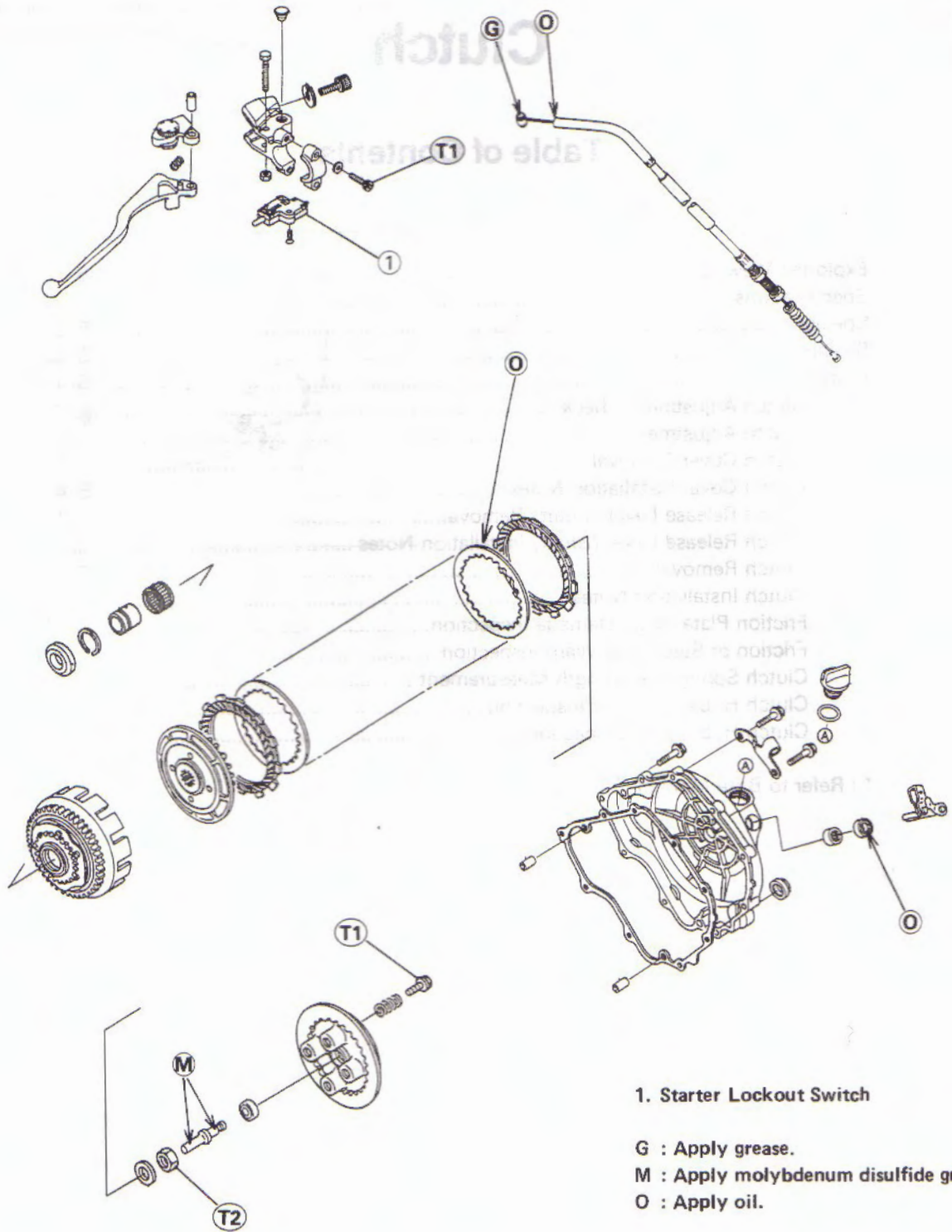

1. Starter Lockout Switch

G : Apply grease.

M : Apply molybdenum disulfide grease.

O : Apply oil.

T1: 8.8 N-m (0.90 kg-m, 78 in-lb)

T2: 130 N-m (13.5 kg-m, 98 ft-lb)

Specifications

Item	Standard	Service Limit
Clutch:		
Clutch lever play	2 ~ 3 mm	---
Clutch spring free length	32.6 mm	31.7 mm
Friction plate thickness	2.9 ~ 3.1 mm	2.8 mm
Friction and steel plate warp	---	0.3 mm

Special Tools

Pressure Cable Luber: K56019-021

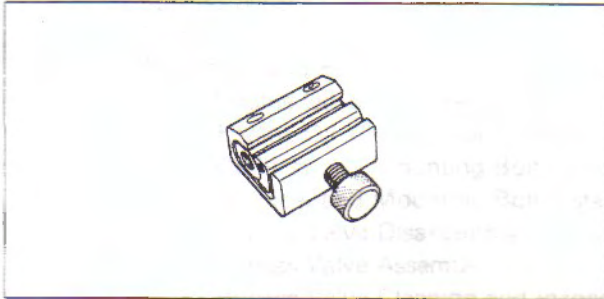

Clutch Holder: 57001-1243

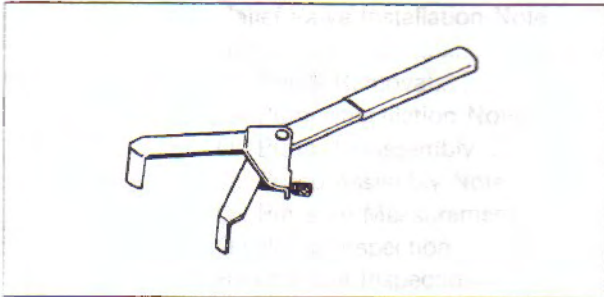

Sealant

Kawasaki Bond (Silicone Sealant): 56019-120

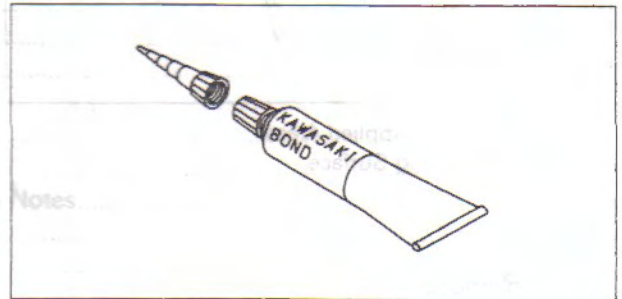

5-4 CLUTCH

Clutch

Clutch Cover Installation Notes

- Replace the clutch cover gasket with a new one.
- Apply a silicone sealant to the following.

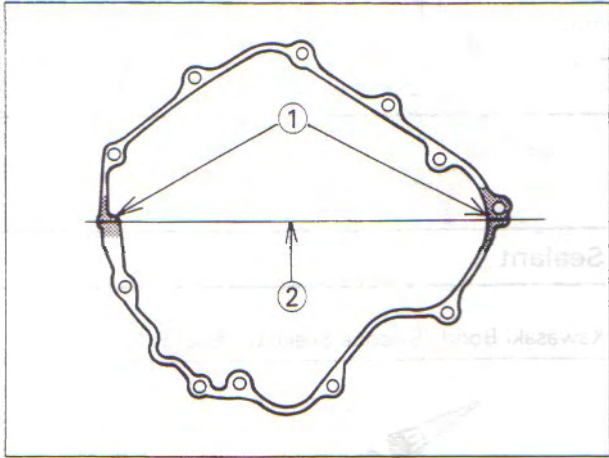

1. Silicone Sealant Applied Areas
2. Crankcase Mating Surface

Clutch Removal

Refer to the Base Manual, noting the following.

- Use the clutch holder (special tool: 57001-1243) to keep the clutch hub from turning.

Engine Lubrication System

Table of Contents

Exploded View	6-2
Engine Oil Flow Chart	*
Specifications	6-3
Special Tools	*
Sealant	6-3
Engine Oil and Filter	*
Engine Oil Level Inspection	*
Engine Oil and/or Filter Change	*
Oil Filter and Mounting Bolt Removal	*
Oil Filter and Mounting Bolt Installation Notes	*
Bypass Valve Disassembly	*
Bypass Valve Assembly	*
Bypass Valve Cleaning and Inspection	*
Relief Valve Removal	*
Relief Valve Installation Note	*
Oil Pump	*
Oil Pump Removal	*
Oil Pump Installation Notes	*
Oil Pump Disassembly	*
Oil Pump Assembly Note	*
Oil Pressure Measurement	*
Oil Pump Inspection	*
Relief Valve Inspection	*

* : Refer to Base Manual

Quick Reference

Specifications

Item	Standard
Engine Oil: Grade Viscosity Capacity	SE or SF class SAE 10W-40, 10W-50, 20W-40, or 20W-50 1.5 L (when filter is not removed) 1.9 L (when filter is removed)
Oil Pressure Measurement: Relief valve opening pressure Oil pressure @4,000 r/min (rpm), oil temp. 90°C (194°F)	430 ~ 590 kPa (4.4 ~ 6.0 kg/cm ² , 63 ~ 85 psi) More than 345 kPa (3.5 kg/cm ² , 50 psi)

Sealant

Kawasaki Bond (Silicone Sealant): 56019-120

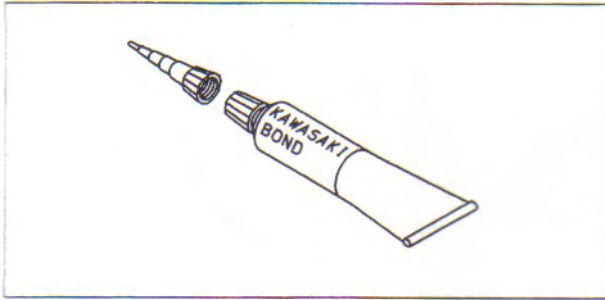

Engine Removal / Installation

Table of Contents

Exploded View	7-2
Engine Removal/Installation	7-3
Engine Removal	7-3
Engine Installation	*

* : Refer to Base Manual

Quick Reference

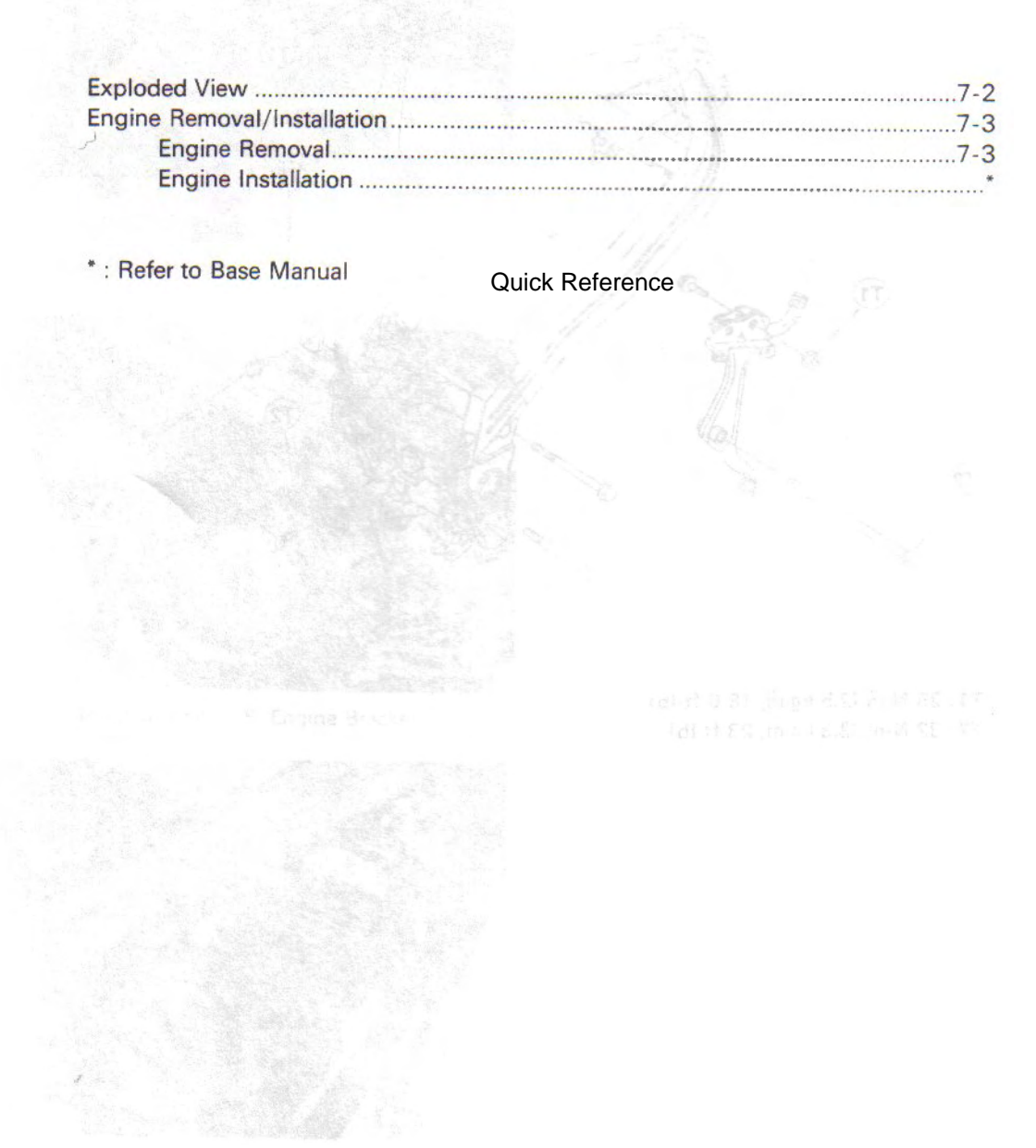

7-2 ENGINE REMOVAL / INSTALLATION

Exploded View

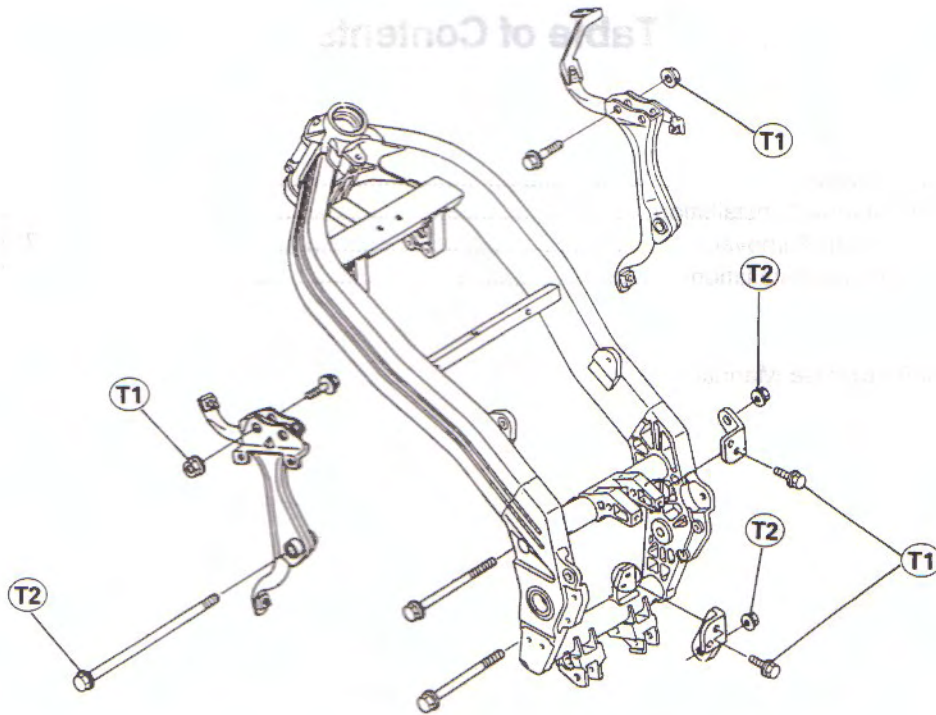

T1: 25 N-m (2.5 kg-m, 18.0 ft-lb)

T2: 32 N-m (3.3 kg-m, 23 ft-lb)

Engine Removal/Installation

Engine Removal

Refer to the Base Manual, noting the following.

- Remove the side stand bracket bolts, and remove the side stand.

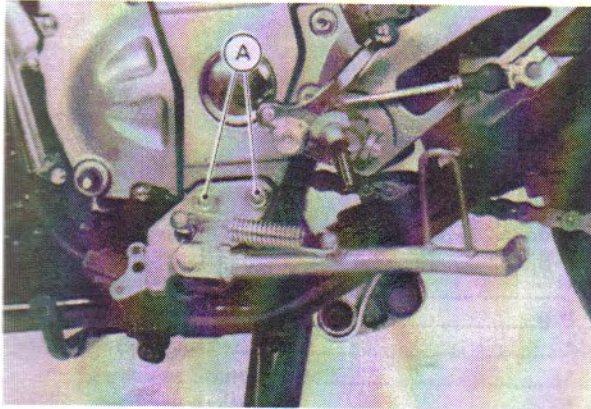

A. Side Stand Bracket Bolts

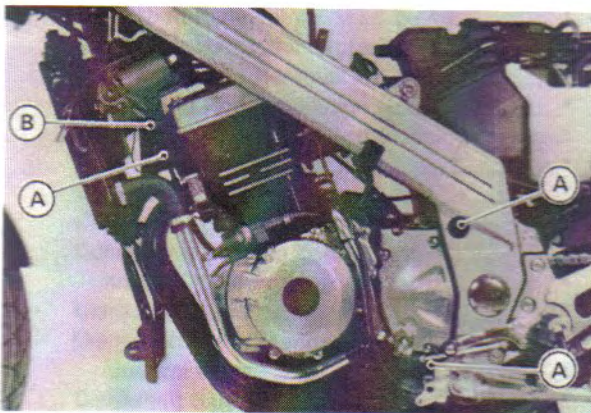

A. Engine Mounting Bolt B. Engine Bracket

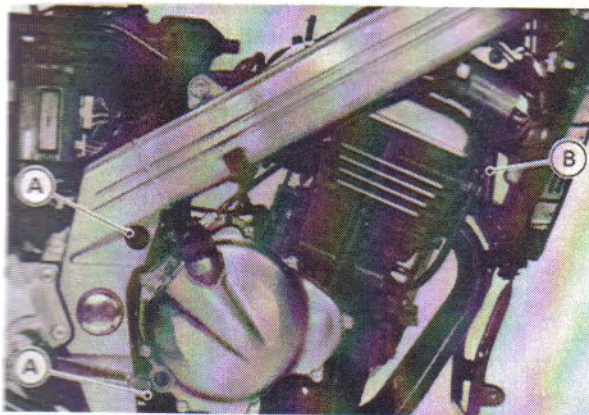

A. Engine Mounting Bolt Nut B. Engine Bracket

Crankshaft / Transmission

Table of Contents

Exploded View.....	8-2	Starter Motor Clutch.....*	
Specifications.....	8-4	Starter Motor Clutch Removal.....*	
Special Tool.....*		Starter Motor Clutch Installation Notes.....*	
Sealant.....	8-6	Starter Motor Clutch Disassembly.....*	
Crankcase Splitting.....*		Starter Motor Clutch Assembly Note.....*	
Crankcase Splitting.....*		Starter Motor Clutch Inspection.....*	
Crankcase Assembly.....*		Transmission.....	8-6
Crankcase Exchange.....*		External Shift Mechanism Removal.....	8-6
Crankshaft/Connecting Rods.....*		External Shift Mechanism	
Crankshaft Removal.....*		Installation Notes.....	8-6
Crankshaft Installation Notes.....*		External Shift Mechanism Inspection.....*	
Connecting Rod Removal.....*		Transmission Shaft Removal.....*	
Connecting Rod Installation Notes.....*		Transmission Shaft Installation.....*	
Crankshaft/Connecting Rod Cleaning.....*		Drive Shaft Disassembly.....*	
Connecting Rod Bend.....*		Drive Shaft Assembly Notes.....*	
Connecting Rod Twist.....*		Output Shaft Disassembly.....*	
Connecting Rod Big End Side Clearance.....*		Output Shaft Assembly Notes.....*	
Connecting Rod Big End Bearing		Shift Drum and Fork Removal.....*	
Insert/Crankpin Wear.....*		Shift Drum and Fork Installation.....*	
Crankshaft Runout.....*		Shift Drum Disassembly Note.....*	
Crankshaft Main Bearing Insert/		Shift Drum Assembly Notes.....*	
Journal Wear.....*		Gear Backlash.....*	
Crankshaft Side Clearance.....*		Shift Fork Bending.....*	
Balancer.....*		Shift Fork/Gear Groove Wear.....*	
Balancer Removal.....*		Shift Fork Guide Pin/Shift	
Balancer Installation Notes.....*		Drum Groove Wear.....*	
Balancer Shaft Bearing Insert/		Gear Dog/Gear Dog Hole Damage.....*	
Journal Wear.....*		Ball and Needle Bearing Wear.....*	

Quick Reference

* : Refer to Base Manual

8-2 CRANKSHAFT / TRANSMISSION

Exploded View

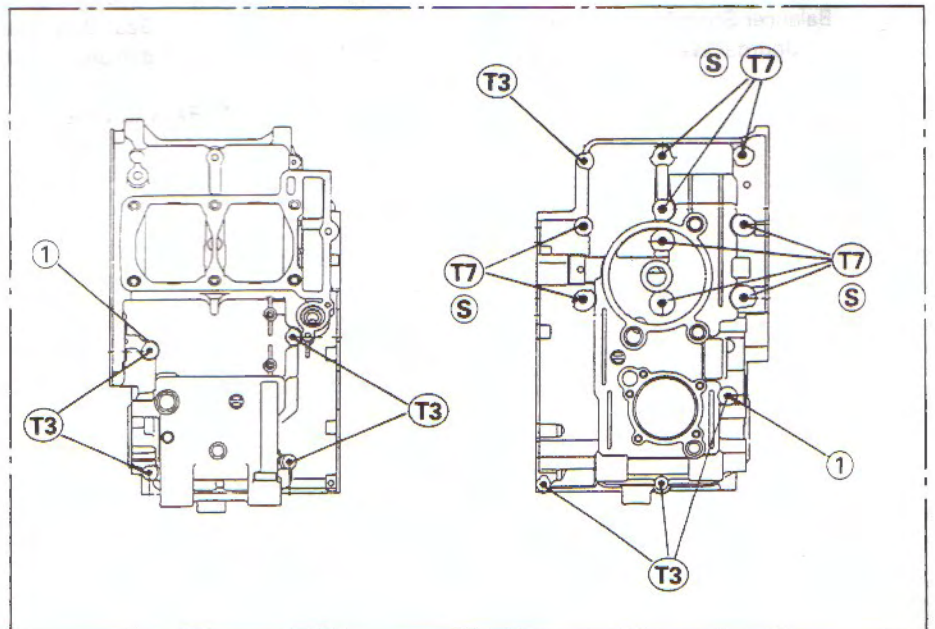
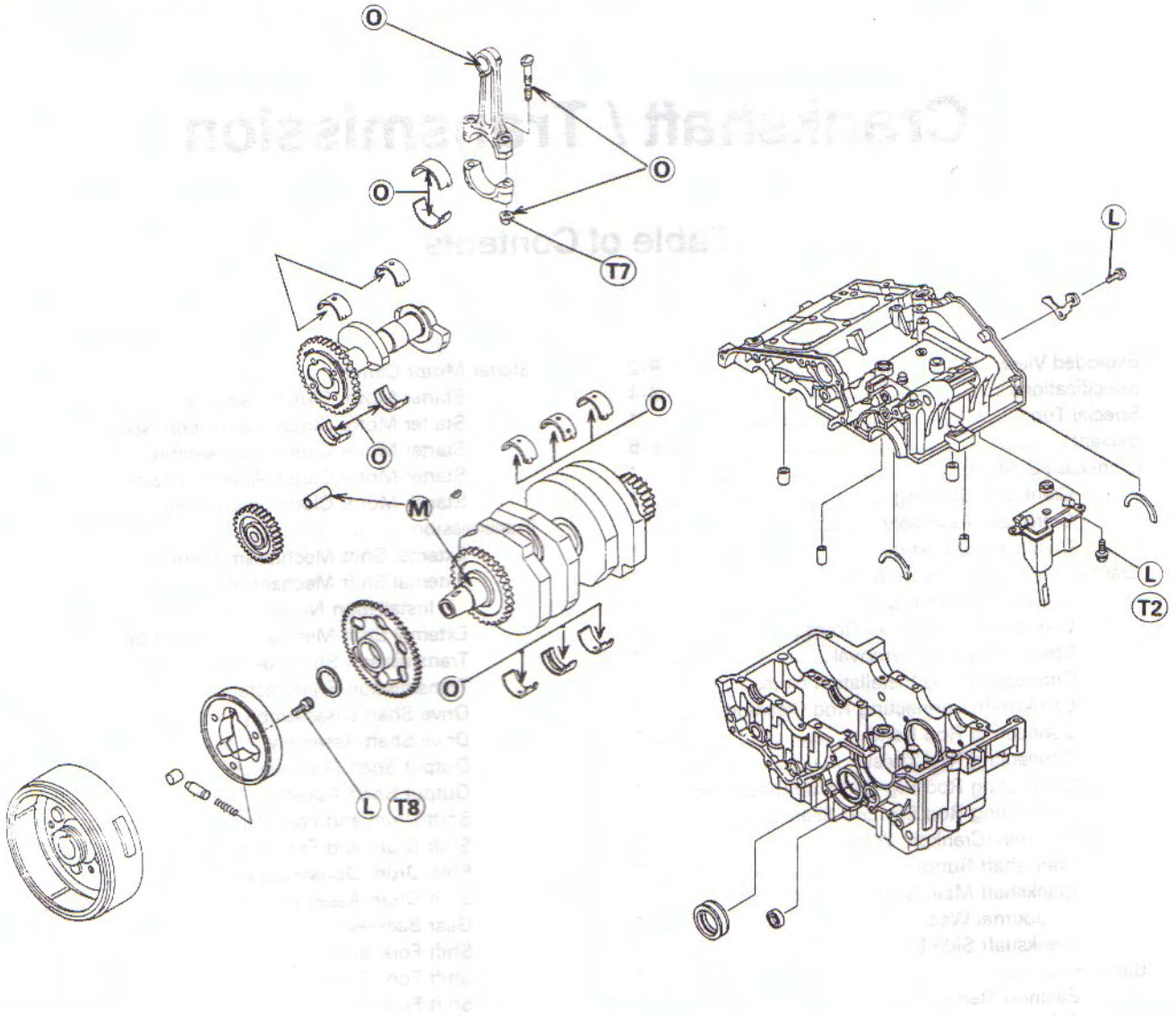

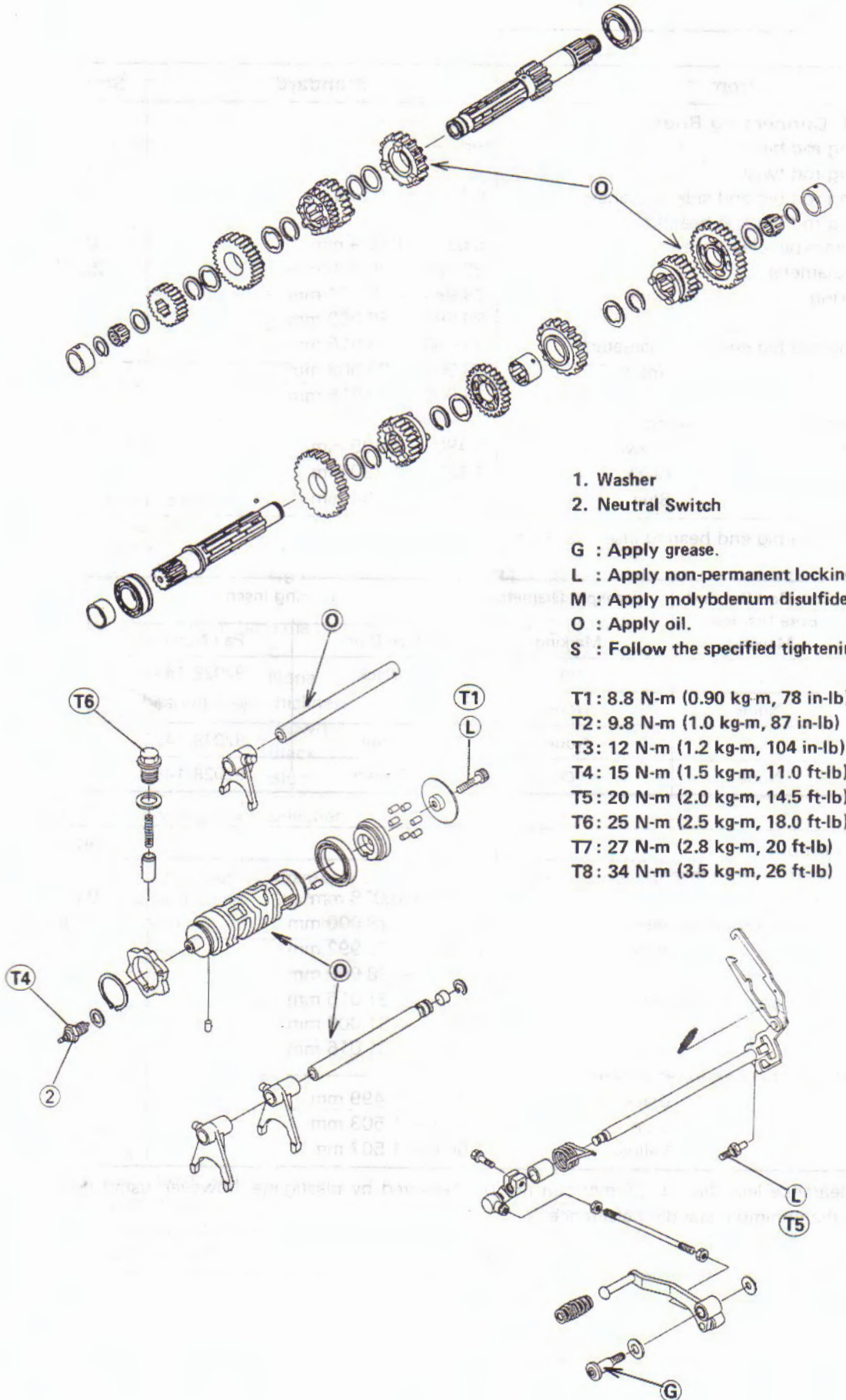

- 1. Washer
- 2. Neutral Switch

G : Apply grease.
 L : Apply non-permanent locking agent.
 M : Apply molybdenum disulfide grease.
 O : Apply oil.
 S : Follow the specified tightening sequence.

- T1 : 8.8 N-m (0.90 kg-m, 78 in-lb)
- T2 : 9.8 N-m (1.0 kg-m, 87 in-lb)
- T3 : 12 N-m (1.2 kg-m, 104 in-lb)
- T4 : 15 N-m (1.5 kg-m, 11.0 ft-lb)
- T5 : 20 N-m (2.0 kg-m, 14.5 ft-lb)
- T6 : 25 N-m (2.5 kg-m, 18.0 ft-lb)
- T7 : 27 N-m (2.8 kg-m, 20 ft-lb)
- T8 : 34 N-m (3.5 kg-m, 26 ft-lb)

8-4 CRANKSHAFT / TRANSMISSION

Specifications

Item	Standard	Service Limit																							
Crankshaft, Connecting Rods:																									
Connecting rod bend	---	0.2/100 mm																							
Connecting rod twist	---	0.2/100 mm																							
Connecting rod big end side clearance	0.13 ~ 0.38 mm	0.50 mm																							
Connecting rod big end bearing insert/crankpin clearance	0.031 ~ 0.059 mm	0.10 mm																							
Crankpin diameter:	29.984 ~ 30.000 mm	29.97 mm																							
Marking	None	---																							
	○	---																							
Connecting rod big end bore diameter:	33.000 ~ 33.016 mm	---																							
Marking	None	---																							
	○	---																							
Connecting rod big end bearing insert thickness:																									
	Brown	---																							
	Black	---																							
	Blue	---																							
	1.480 ~ 1.485 mm																								
	1.485 ~ 1.490 mm																								
	1.489 ~ 1.494 mm																								
Connecting rod big end bearing insert selection:																									
<table border="1"> <thead> <tr> <th rowspan="2">Con-Rod Big End Bore Diameter Marking</th> <th rowspan="2">Crankpin Diameter Marking</th> <th colspan="2">Bearing Insert</th> </tr> <tr> <th>Size Color</th> <th>Part Number</th> </tr> </thead> <tbody> <tr> <td>○</td> <td>○</td> <td>Black</td> <td>92028-1493</td> </tr> <tr> <td>None</td> <td>None</td> <td></td> <td></td> </tr> <tr> <td>○</td> <td>None</td> <td>Blue</td> <td>92028-1492</td> </tr> <tr> <td>None</td> <td>○</td> <td>Brown</td> <td>92028-1494</td> </tr> </tbody> </table>				Con-Rod Big End Bore Diameter Marking	Crankpin Diameter Marking	Bearing Insert		Size Color	Part Number	○	○	Black	92028-1493	None	None			○	None	Blue	92028-1492	None	○	Brown	92028-1494
Con-Rod Big End Bore Diameter Marking	Crankpin Diameter Marking	Bearing Insert																							
		Size Color	Part Number																						
○	○	Black	92028-1493																						
None	None																								
○	None	Blue	92028-1492																						
None	○	Brown	92028-1494																						
Crankshaft runout	---	0.05 mm TIR																							
Crankshaft main bearing insert/journal clearance	0.014 ~ 0.038 mm*	0.08 mm																							
Crankshaft main journal diameter:	27.984 ~ 28.000 mm	27.96 mm																							
Marking	None	---																							
	1	---																							
Crankcase main bearing bore diameter:	31.000 ~ 31.016 mm	---																							
Marking	○	---																							
	None	---																							
Crankshaft main bearing insert thickness:																									
	Black	---																							
	Blue	---																							
	Yellow	---																							
	1.495 ~ 1.499 mm																								
	1.499 ~ 1.503 mm																								
	1.503 ~ 1.507 mm																								

* : Journal clearance less than 0.025 mm can not be measured by plastigage, however, using genuine parts maintains the minimum standard clearance.

Item	Standard	Service Limit																																		
Crankshaft main bearing insert selection:																																				
<table border="1"> <thead> <tr> <th rowspan="2">Crankcase Main Bearing Bore Diameter Marking</th> <th rowspan="2">Crankshaft Main Journal Diameter Marking</th> <th colspan="3">Bearing Insert**</th> </tr> <tr> <th>Size Color</th> <th>Part Number</th> <th>Journal Nos.</th> </tr> </thead> <tbody> <tr> <td rowspan="2">○</td> <td rowspan="2">1</td> <td rowspan="2">Black</td> <td>92028-1487</td> <td>1, 3</td> </tr> <tr> <td>92028-1490</td> <td>2</td> </tr> <tr> <td rowspan="2">None</td> <td rowspan="2">None</td> <td rowspan="2">Yellow</td> <td>92028-1582</td> <td>1, 3</td> </tr> <tr> <td>92028-1586</td> <td>2</td> </tr> <tr> <td rowspan="2">○</td> <td rowspan="2">None</td> <td rowspan="2">Blue</td> <td>92028-1486</td> <td>1, 3</td> </tr> <tr> <td>92028-1489</td> <td>2</td> </tr> <tr> <td>None</td> <td>1</td> <td></td> <td></td> <td></td> </tr> </tbody> </table>			Crankcase Main Bearing Bore Diameter Marking	Crankshaft Main Journal Diameter Marking	Bearing Insert**			Size Color	Part Number	Journal Nos.	○	1	Black	92028-1487	1, 3	92028-1490	2	None	None	Yellow	92028-1582	1, 3	92028-1586	2	○	None	Blue	92028-1486	1, 3	92028-1489	2	None	1			
Crankcase Main Bearing Bore Diameter Marking	Crankshaft Main Journal Diameter Marking	Bearing Insert**																																		
		Size Color	Part Number	Journal Nos.																																
○	1	Black	92028-1487	1, 3																																
			92028-1490	2																																
None	None	Yellow	92028-1582	1, 3																																
			92028-1586	2																																
○	None	Blue	92028-1486	1, 3																																
			92028-1489	2																																
None	1																																			
**The bearing inserts for No. 2 journal have an oil groove.																																				
Crankshaft side clearance	0.05 ~ 0.20 mm	0.40 mm																																		
Balancer: Balancer shaft bearing insert/ journal clearance Balancer shaft journal diameter: Marking None ○ Crankcase balancer shaft bore diameter: Marking ○ None Balancer shaft bearing insert thickness: Brown Black Blue	0.020 ~ 0.044 mm 25.984 ~ 26.000 mm 25.984 ~ 25.994 mm 25.995 ~ 26.000 mm 29.000 ~ 29.016 mm 29.000 ~ 29.008 mm 29.009 ~ 29.016 mm 1.495 ~ 1.499 mm 1.499 ~ 1.503 mm 1.503 ~ 1.507 mm	0.08 mm 25.96 mm --- --- --- --- --- --- --- --- --- --- ---																																		
Balancer shaft bearing insert selection:																																				
<table border="1"> <thead> <tr> <th rowspan="2">Balancer Shaft Journal Diameter Marking</th> <th rowspan="2">Crankcase Balacner Shaft Bore Diameter Marking</th> <th colspan="2">Bearing Insert</th> </tr> <tr> <th>Size Color</th> <th>Part Number</th> </tr> </thead> <tbody> <tr> <td>○</td> <td>○</td> <td>Brown</td> <td>92028-1424</td> </tr> <tr> <td>○</td> <td>None</td> <td rowspan="2">Black</td> <td rowspan="2">92028-1423</td> </tr> <tr> <td>None</td> <td>○</td> </tr> <tr> <td>None</td> <td>None</td> <td>Blue</td> <td>92028-1422</td> </tr> </tbody> </table>			Balancer Shaft Journal Diameter Marking	Crankcase Balacner Shaft Bore Diameter Marking	Bearing Insert		Size Color	Part Number	○	○	Brown	92028-1424	○	None	Black	92028-1423	None	○	None	None	Blue	92028-1422														
Balancer Shaft Journal Diameter Marking	Crankcase Balacner Shaft Bore Diameter Marking	Bearing Insert																																		
		Size Color	Part Number																																	
○	○	Brown	92028-1424																																	
○	None	Black	92028-1423																																	
None	○																																			
None	None	Blue	92028-1422																																	
Transmission: Gear backlash Gear shift fork groove width Shift fork ear thickness Shift fork guide pin diameter Shift drum groove width	0 ~ 0.18 mm 5.05 ~ 5.15 mm 4.9 ~ 5.0 mm 5.9 ~ 6.0 mm 6.05 ~ 6.20 mm	0.25 mm 5.3 mm 4.8 mm 5.8 mm 6.3 mm																																		

8-6 CRANKSHAFT / TRANSMISSION

Sealant

Kawasaki Bond (Liquid Gasket – Black): 92104-1003

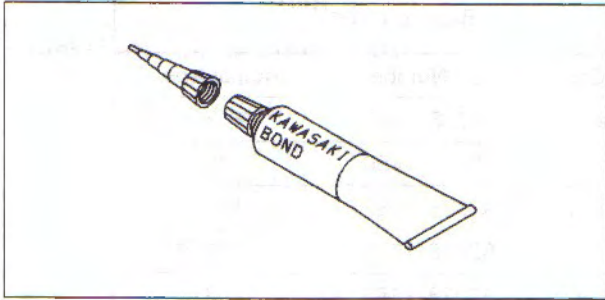

Transmission

External Shift Mechanism Removal

Refer to the Base Manual, noting the following.

- Before removing the shift lever off the shift shaft, mark the position of the lever on the shaft so that it can be installed after in the same position.

External Shift Mechanism Installation Notes

Refer to the Base Manual, noting the following.

- Adjust the shift pedal position correctly if the shift pedal linkage was disassembled.
- Loosen the locknuts and turn the rod to adjust the shift pedal position. The front locknut has left-hand threads.
- Tighten the locknuts.
- The standard shift pedal position is about 30 mm lower than the top of the footpeg with the shift levers almost parallel to each other.

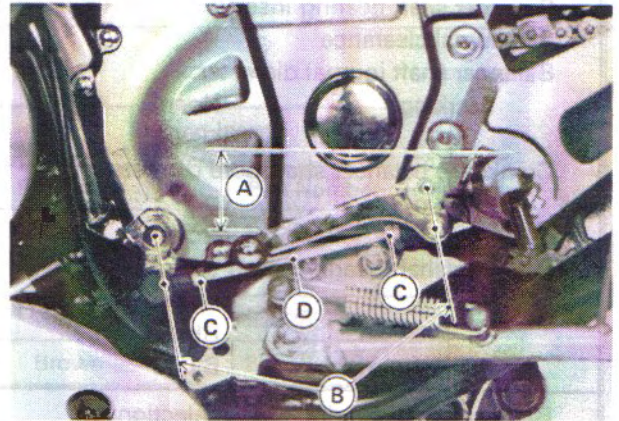

A. About 30 mm
B. Almost Parallel

C. Locknut
D. Rod

Wheels / Tires

Table of Contents

Exploded View	9-2
Specifications	9-3
Special Tools	9-4
Wheels (Rims)	9-5
Front Wheel Removal	9-5
Front Wheel Installation	9-5
Rear Wheel Removal	9-6
Rear Wheel Installation	9-6
Wheel Inspection	*
Axle Inspection	*
Wheel Balance	*
Tires	9-7
Tire Removal	*
Tire Installation	9-7
Tire Inspection	*
Tire Repair	*
Hub Bearings	9-8
Hub Bearing Removal	9-8
Hub Bearing Installation	9-8
Hub Bearing Inspection	9-8
Grease Seal Inspection	*
Speedometer Gear Housing	*
Speedometer Gear Housing Disassembly	*
Speedometer Gear Housing Assembly	*

* : Refer to Base Manual

Quick Reference

9-2 WHEELS / TIRES

Exploded View

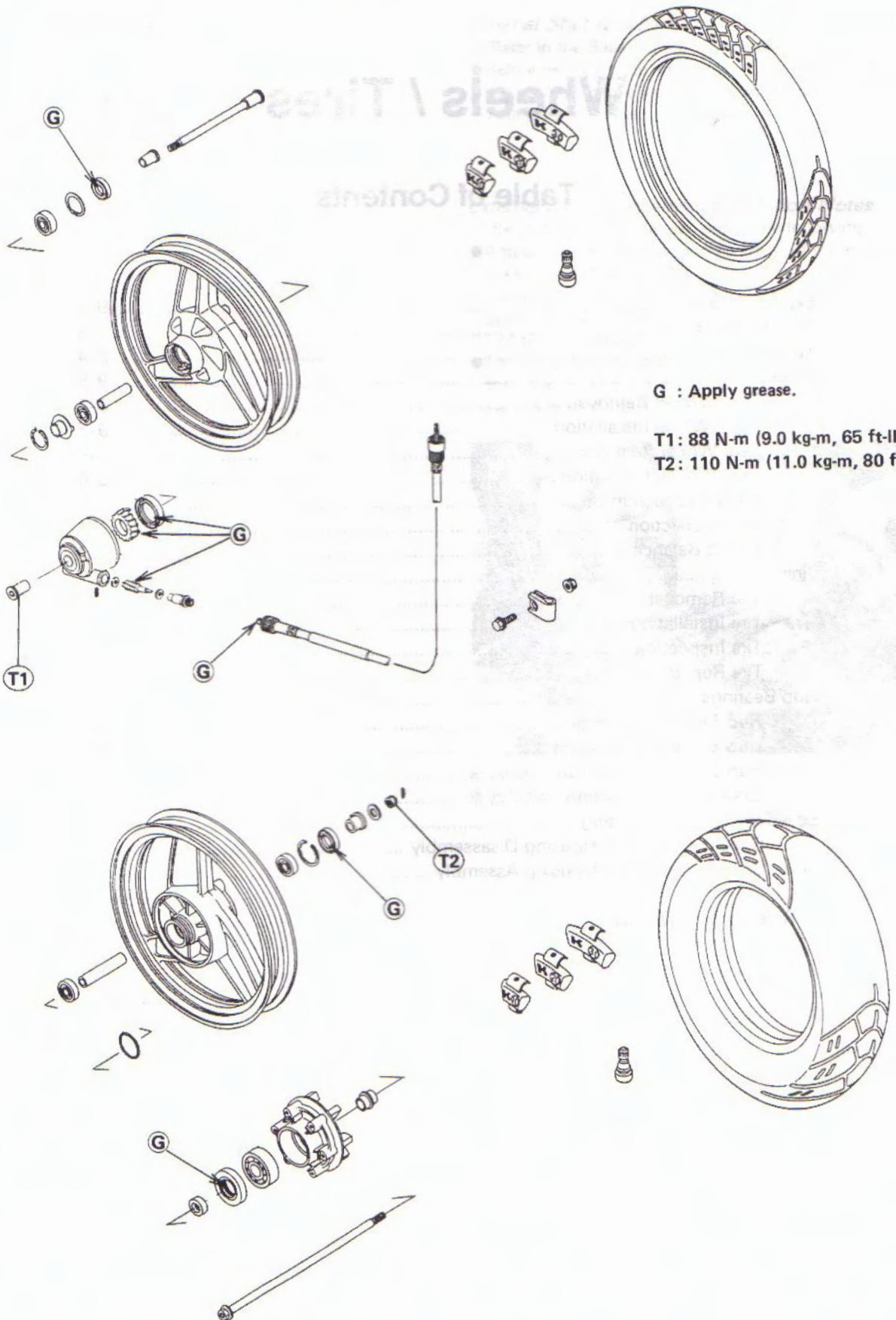

Specifications

Item	Standard	Service Limit
Wheels:		
Rim runout: Axial	---	0.5 mm
Radial	---	0.8 mm
Axle runout/100 mm	---	0.2 mm
Tires:		
Tire air pressure:		
Front	---	200 kPa (2.00 kg/cm ² , 28 psi)
Rear	Up to 155 kg (342 lb) load	225 kPa (2.25 kg/cm ² , 32 psi)
Standard tire:		
Front	1. 100/80-17 52S DUNLOP K275F	Tubeless
	2. 100/80R17 52T DUNLOP SPORTMAX	Tubeless
	3. 100/80-17 52H PIRELLI MT75	FRONT Tubeless
Rear	1. 140/70-17 66S DUNLOP K275	Tubeless
	2. 140/70R17 66T DUNLOP SPORTMAX	Tubeless
	3. 140/70-17 66H PIRELLI MT75	Tubeless
No. 2 and 3 are replacement tires for Europe Models		
Tire tread depth:	Front Rear	4.0 mm 6.0 mm
		1 mm 2 mm (Under 130 km/h, Under 80 mph) 3 mm (Over 130 km/h, Over 80 mph)

9-4 WHEELS / TIRES

Special Tools

Inside Circlip Pliers: 57001-143

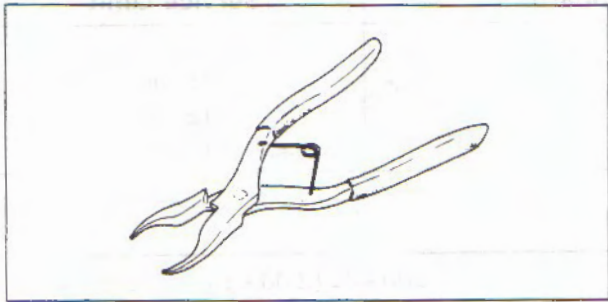

Bearing Remover Head, $\phi 15 \times \phi 17$: 57001-1267



Rim Protector: 57001-1063

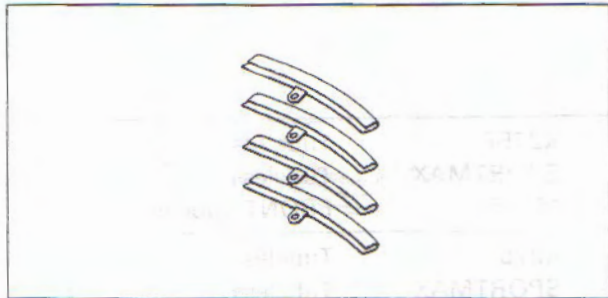

Bead Breaker Assembly: 57001-1072

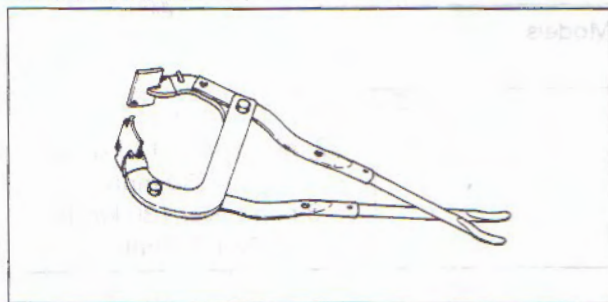

Bearing Driver Set: 57001-1129



Bearing Remover Shaft: 57001-1265



Wheels (Rims)

Front Wheel Removal

- Remove the following.
 - Speedometer Cable Lower End

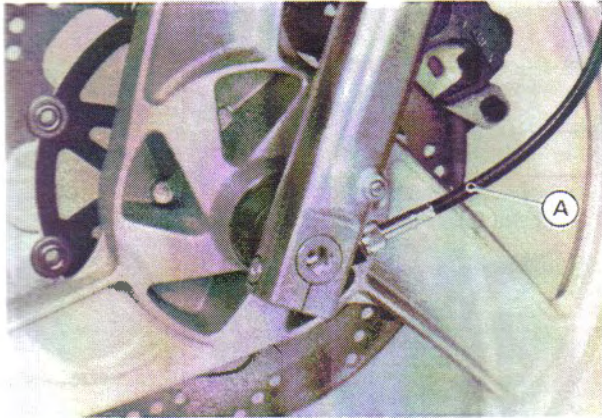

A. Speedometer Cable

- Right Side Axle Clamp Bolt (loosen)
- Axle (loosen)

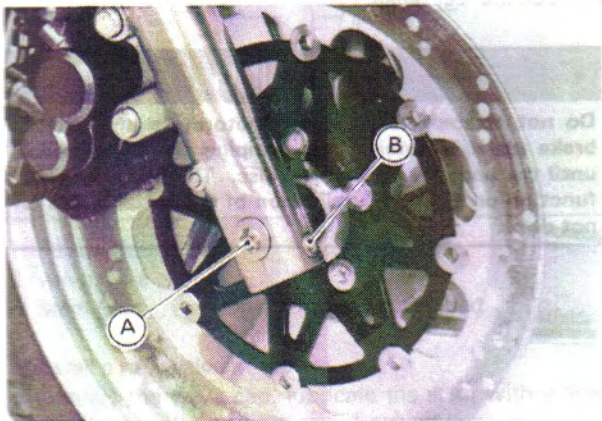

A. Axle B. Axle Clamp Bolt

- Using a jack, raise the front wheel off the ground.
- Pull the axle and remove the front wheel.

CAUTION

Do not lay the wheel on the ground with the disc facing down. This can damage or warp the disc. Place blocks under the wheel so that the disc does not touch the ground.

Front Wheel Installation

- Installation is the reverse of removal. Note the following.
 - Apply a high-temperature grease to the following.
 - Grease Seal Lips
 - Install the speedometer gear housing so that it fits in the speedometer gear drive notches.

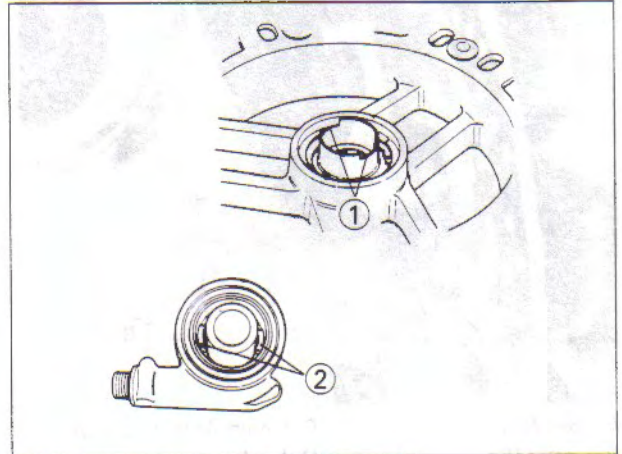

1. Notches 2. Projections

- Fit the speedometer gear housing stop into the fork leg stops.

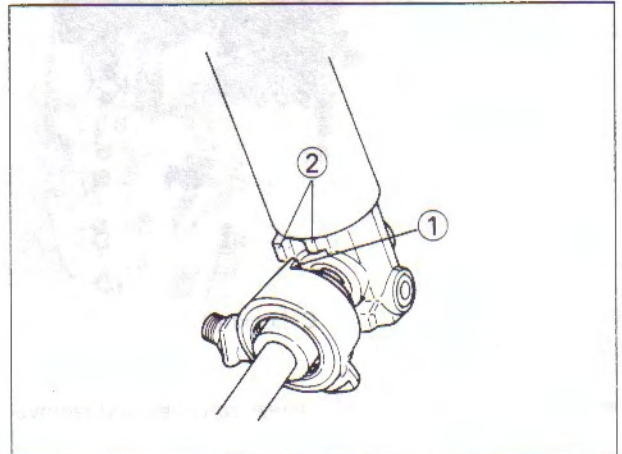

1. Housing Stop 2. Fork Leg Stops

- Torque the following (see Exploded View).
 - Axle Nut
 - Axle Clamp Bolts
- Check the front brake.

WARNING

Do not attempt to drive the motorcycle until a full brake lever is obtained by pumping the brake lever until the pads are against the disc. The brake will not function on the first application of the lever if this is not done.

9-6 WHEELS / TIRES

Rear Wheel Removal

- Remove the following.
 - Axle Nut Cotter Pin
 - Axle Nut and Washer
 - Chain Adjusting Nuts and Locknuts (loosen)
 - Axle
 - Alignment Indicators

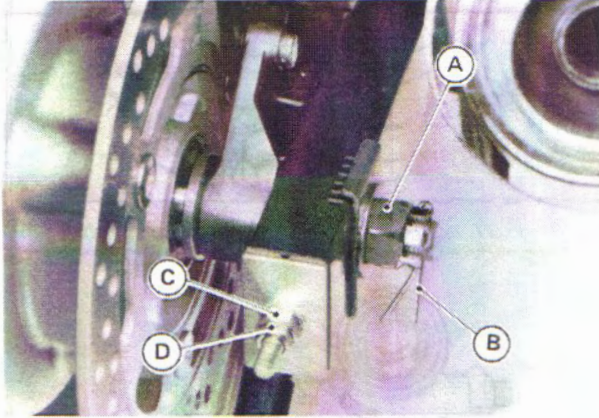

A. Axle Nut
B. Cotter Pin
C. Chain Adjusting Nut
D. Locknut

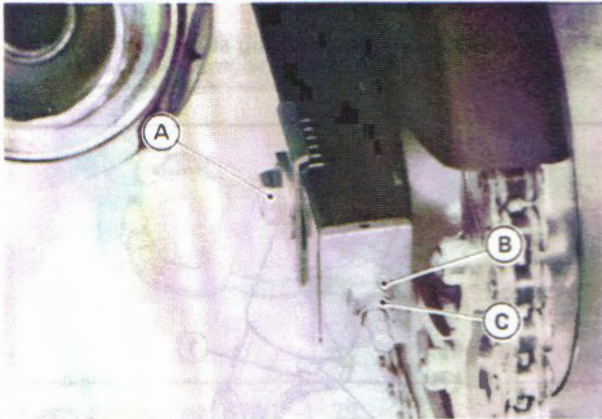

A. Axle
B. Chain Adjusting Nut
C. Locknut

- Free the drive chain from the rear sprocket, and remove the rear wheel.

CAUTION

Do not lay the wheel on the ground with the disc facing down. This can damage or warp the disc. Place blocks under the wheel so that the disc does not touch the ground.

Rear Wheel Installation

- Installation is the reverse of removal. Note the following.
- Apply grease to the following.
 - Grease Seal Lips
 - Coupling/Wheel Sliding Portions
- Fit the swing arm stop into the caliper holder stops.

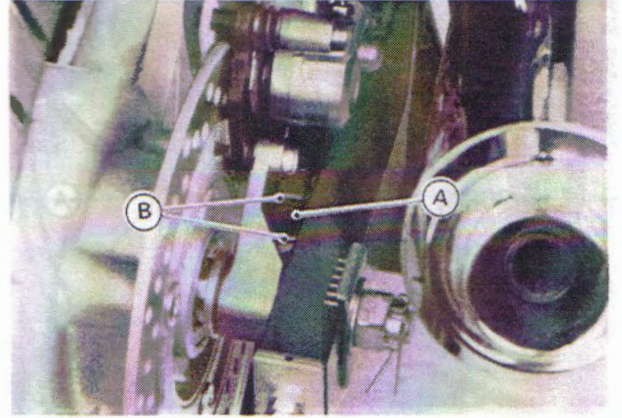

A. Swing Arm Stop
B. Caliper Holder Stops

- Adjust the following.
 - Drive Chain Slack
- Check the rear brake.

⚠ WARNING

Do not attempt to drive the motorcycle until a full brake pedal is obtained by pumping the brake pedal until the pads are against the disc. The brake will not function on the first application of the pedal if this is not done.

Tires

Tire Installation

Refer to the Base Manual, noting the following.

- Remove the air valve and discard it.

CAUTION

Replace the air valve whenever the tire is replace.
Do not reuse the air valve.

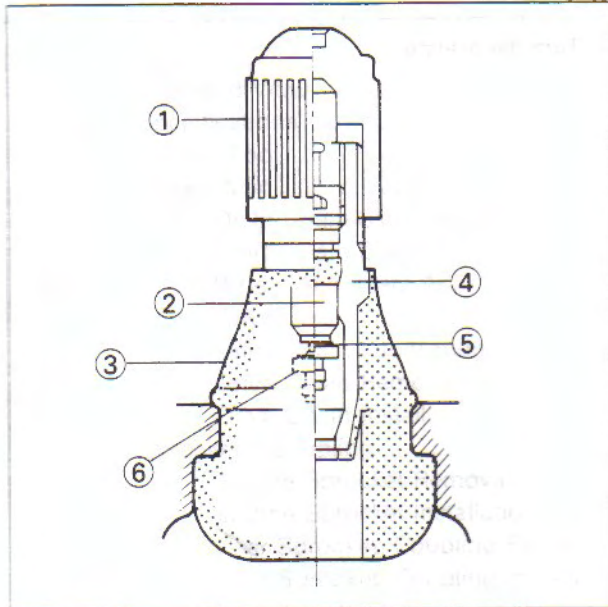

- | | |
|----------------|-----------------|
| 1. Plastic Cap | 4. Valve Stem |
| 2. Valve Core | 5. Valve Seat |
| 3. Stem Seal | 6. Valve Opened |

- Install a new valve in the rim.
- Remove the valve cap, lubricate the stem with a soap and water solution, and pull the stem through the rim from the inside out until it snaps into place.

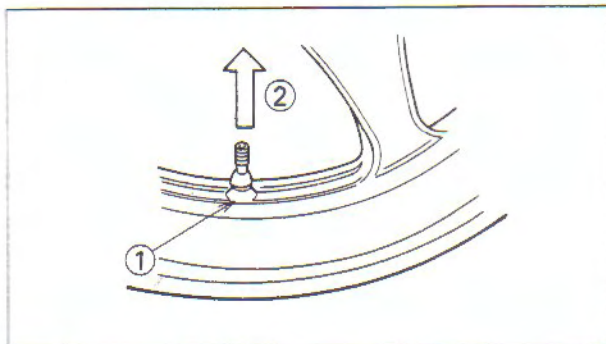

1. Apply soap and water solution.
2. Pull the stem out.

CAUTION

Do not use engine oil or petroleum distillates to lubricate the stem because they will deteriorate the rubber.

9-8 WHEELS / TIRES

Hub Bearings

Hub Bearing Removal

- Remove the following.
 - Wheel
 - Grease Seals and Circlips
- Use the bearing remover shaft and head (special tools) to remove the hub bearings.

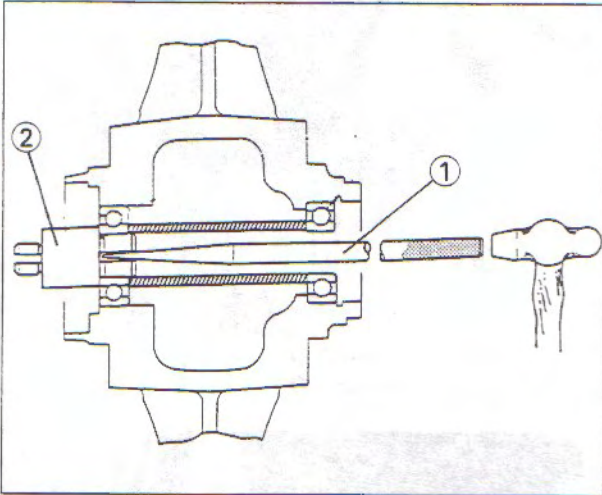

1. Bearing Remover Shaft: 57001-1265
2. Bearing Remover Head: 57001-1267

CAUTION

Do not lay the wheel on the ground with the disc facing down. This can damage or warp the disc. Place blocks under the wheel so that the disc does not touch the ground.

Hub Bearing Installation

- Before installing the bearings, blow any dirt or foreign particles out of the hub with compressed air to prevent contamination of the bearings.
- Install the bearings using the bearing driver set (special tool: 57001-1129) so that the marked sides face out.

Hub Bearing Inspection

- Turn each bearing back and forth while checking for roughness or binding.
- ★ If roughness or binding is found, replace the bearing.
- Examine the bearing seal for tears or leakage.
- ★ If the seal is torn or is leaking, replace the bearing.

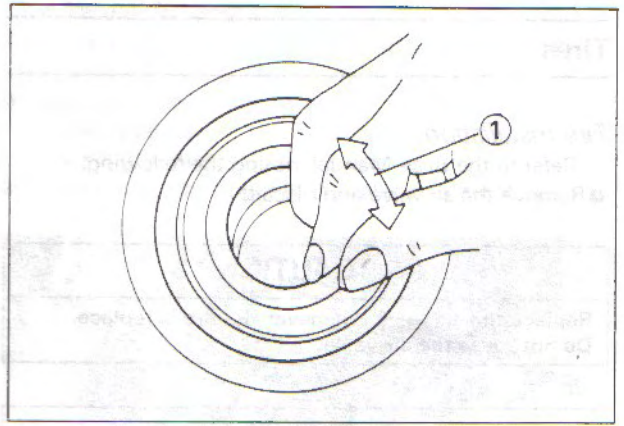

1. Turn the bearing.

Final Drive

Table of Contents

Exploded View	10-2
Specifications	10-3
Special Tool	*
Drive Chain.....	10-4
Drive Chain Slack Inspection.....	10-4
Drive Chain Slack Adjustment.....	10-4
Wheel Alignment Adjustment.....	10-4
Drive Chain Wear Inspection	*
Drive Chain Lubrication.....	*
Drive Chain Removal	10-5
Drive Chain Installation.....	10-5
Sprockets, Coupling.....	10-5
Engine Sprocket Removal.....	10-5
Engine Sprocket Installation	10-6
Rear Sprocket, Coupling Removal.....	*
Rear Sprocket, Coupling Installation	*
Sprocket Wear	*
Sprocket Warp	*
Coupling Bearing Removal	*
Coupling Bearing Installation.....	*
Coupling Bearing Inspection and Lubrication.....	*
Grease Seal Inspection	*
Damper Inspection	*

* : Refer to Base Manual

Quick Reference

Apply grease
 Apply and assemble from top
 T: 88 N m (6.5 kg-m) 5.5 ft-lb
 T5: 22 N m (1.7 kg-m) 1.7 ft-lb

10-2 FINAL DRIVE

Exploded View

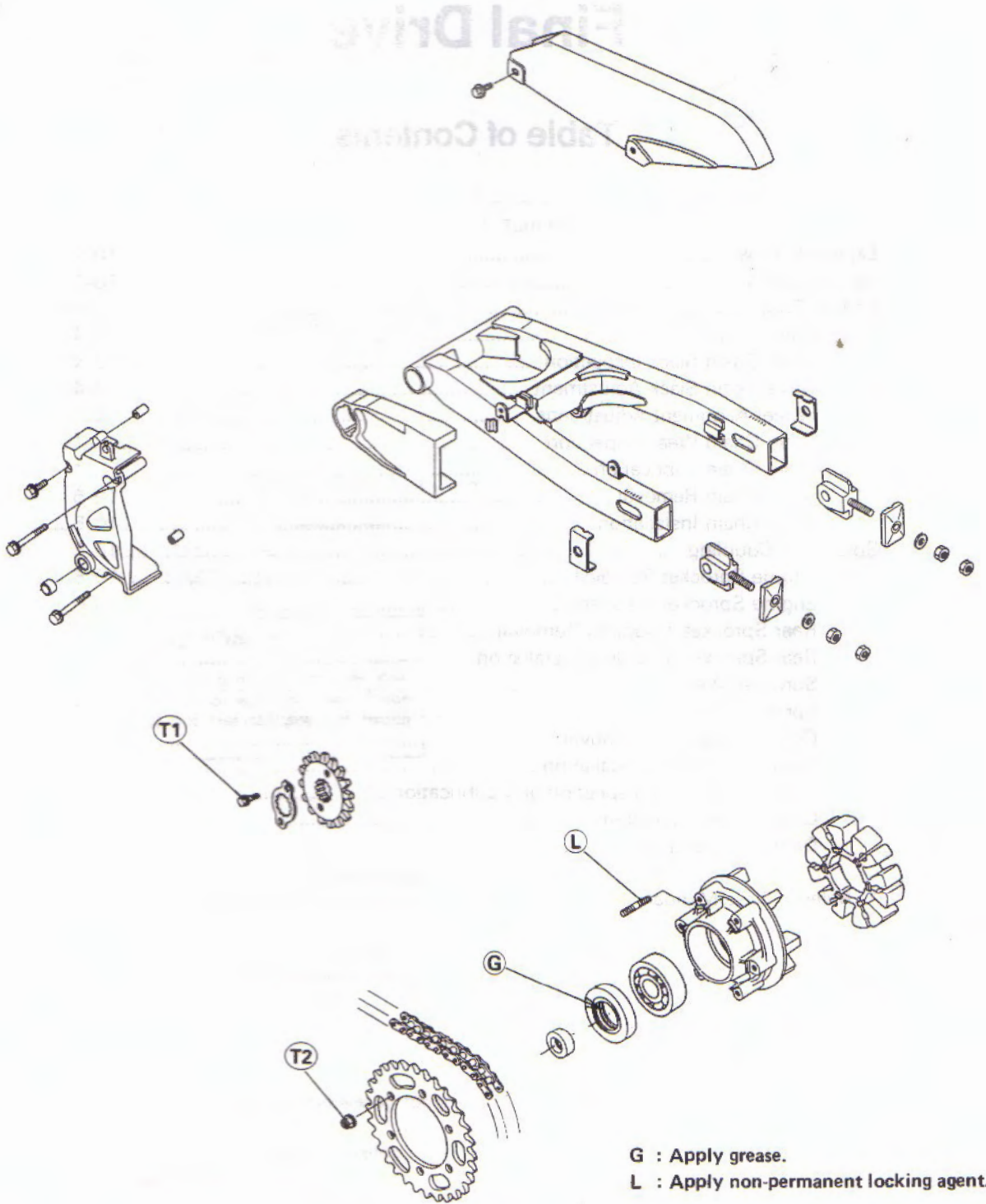

G : Apply grease.

L : Apply non-permanent locking agent.

T1 : 9.8 N-m (1.0 kg-m, 87 in-lb)

T2 : 59 N-m (6.0 kg-m, 43 ft-lb)

Specifications

Item	Standard	Service Limit
Drive Chain:		
Make, type	Enuma, endless EK520LV-O 108 links	--- ---
Chain slack	35 ~ 40 mm	(usable range) Less than 35 mm, or more than 45 mm
20-link length	317.5 ~ 318.2 mm	323 mm
Sprockets:		
Engine sprocket diameter:		
14T	60.99 ~ 61.19 mm	60.7 mm
15T	65.58 ~ 65.78 mm	65.3 mm
Rear sprocket diameter	227.43 ~ 227.93 mm	227.1 mm
Rear sprocket warp	---	0.5 mm

WARNING

Improper adjustment of the wheel alignment may result in a tire skid, uneven tire wear, and a noisy ride. The wheel alignment should be checked and adjusted after the following operations:

- After the engine is repaired.
- After the engine is replaced.
- After the engine is overhauled.
- After the engine is replaced with a new one.
- After the engine is replaced with a used one.
- After the engine is replaced with a remanufactured one.
- After the engine is replaced with a rebuilt one.
- After the engine is replaced with a reconditioned one.
- After the engine is replaced with a reworked one.
- After the engine is replaced with a reworked one.
- After the engine is replaced with a reworked one.

WARNING

Do not touch the engine parts when the engine is hot. The engine parts may be very hot and cause a burn. Use caution when working on the engine.

Wheel Alignment Adjustment

Check the wheel alignment after the engine is repaired. The right and left notches on the engine should point to the same mark on the swing arm.

★ If they are not adjusted, the wheel alignment will be off.



Standard: 35 ~ 40 mm
 Usable Range: Less than 35 mm or more than 45 mm

Engine Sprocket Holding Plate

10-4 FINAL DRIVE

Drive Chain

Drive Chain Slack Inspection

- Set the motorcycle up on its center stand.
- Check to see that the notches on the alignment indicators on both sides are in the same position.

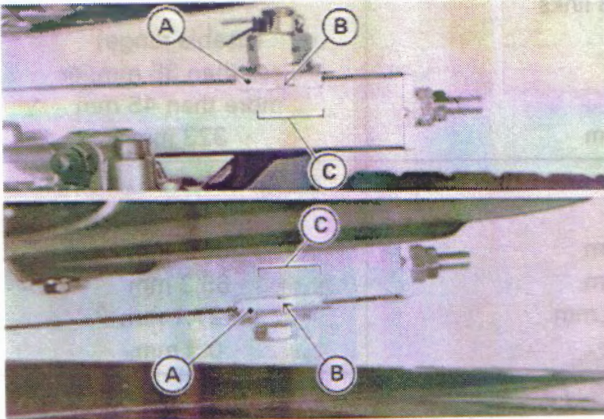

A. Alignment Indicator C. Swing Arm Marks
B. Notch

NOTE

○ Clean the chain if it is dirty, and lubricate it if it appears dry.

- Turn the rear wheel to find the position where the chain is tightest.
- Measure the vertical movement midway between the sprockets.
- ★ If the chain slack exceeds the usable range adjust it.

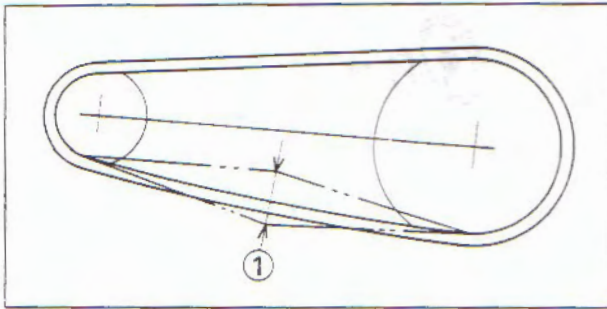

1. Chain Slack

Chain Slack

Standard: 35 ~ 40 mm
Usable Range: Less than 35 mm, or more than 45 mm

Drive Chain Slack Adjustment

- Remove the following.
 - Axle Nut Cotter Pin
 - Axle Nut (loosen)
 - Chain Adjuster Locknuts (loosen)

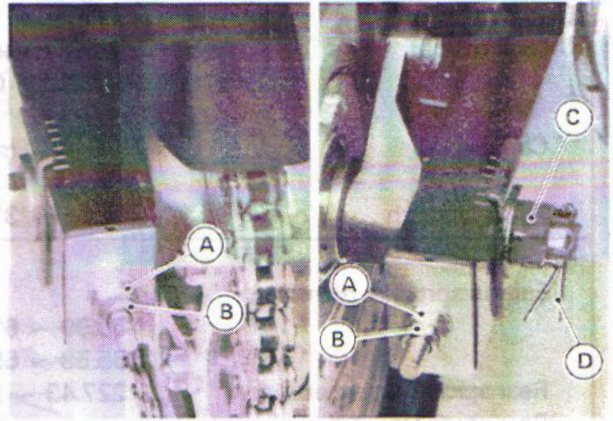

A. Chain Adjusting Nut C. Axle Nut
B. Locknut D. Cotter Pin

- Turn the chain adjusting nuts forward or rearward until the drive chain has the correct amount of chain slack.
- The right and left notches on the alignment indicators should point to the same marks or positions on the swing arm.

⚠ WARNING

Misalignment of the wheel will result in abnormal wear and may result in an unsafe riding condition.

- Tighten the adjuster locknuts securely.
- Torque the following (see Exploded View).
 - Axle Nut
- Insert a new cotter pin through the axle and nut, and spread its ends.

⚠ WARNING

If the axle nut is not securely tightened and the cotter pin is not installed, an unsafe riding condition may result.

- Check the rear brake effectiveness.

Wheel Alignment Adjustment

- Check to see if wheel alignment is properly adjusted. The right and left notches on the alignment indicators should point to the same marks or positions on the swing arm.
- ★ If they are not, adjust the chain slack and align the wheel alignment (see Drive Chain Slack Adjustment).

⚠ WARNING

Misalignment of the wheel will result in abnormal wear and may result in an unsafe riding condition.

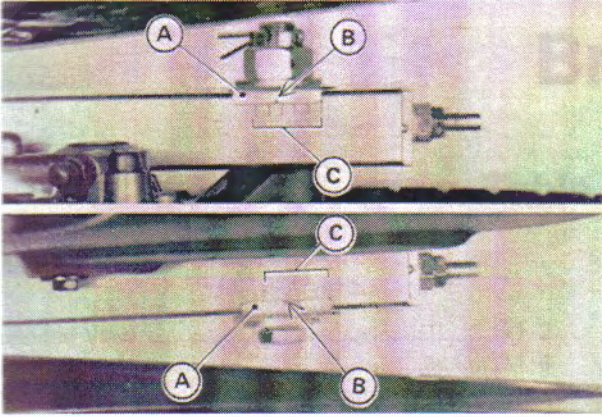

A. Alignment Indicator
B. Notch
C. Swing Arm Marks

Drive Chain Removal

- Remove the following.
 - Engine Sprocket Cover
 - Drive Chain Cover
 - Rear Shock Absorber
 - Swing Arm Pivot Shaft

NOTE

- The swing arm may be moved with the rear wheel left installed on it.

Drive Chain

Drive Chain Installation

- Installation is the reverse of removal. Note the following.
- Torque the following.
 - Swing Arm Pivot Nut
- Adjust the following.
 - Drive Chain Slack

Sprockets, Coupling**Engine Sprocket Removal**

- Before removing the shift lever off the shift shaft, mark the position of the lever on the shift shaft so that it can be installed after in the same position.
- Remove the following.
 - Engine Sprocket Cover

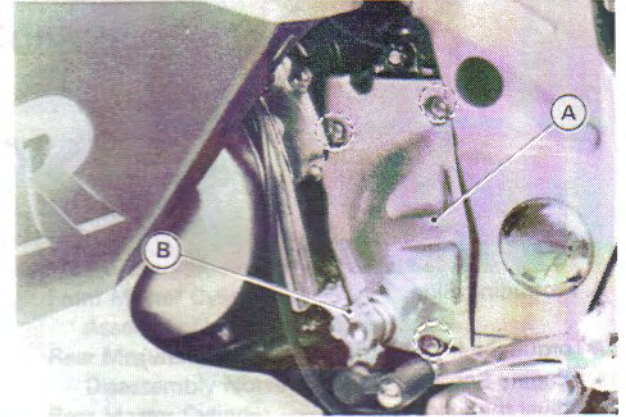

A. Engine Sprocket Cover B. Shift Lever

Engine Sprocket Bolts

Reservoir Removal

Reservoir Installation

NOTE

- When loosening or tightening the engine sprocket bolts, hold the rear brake on.

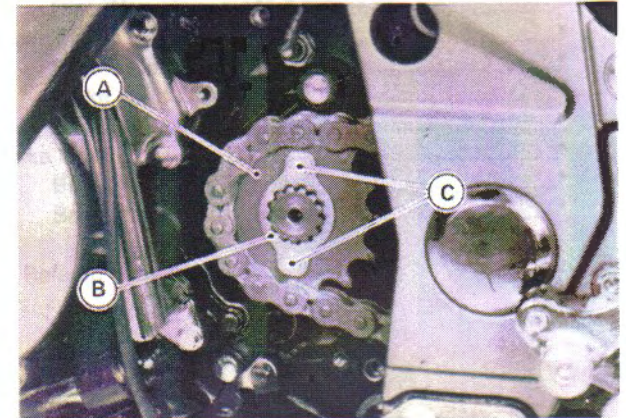

A. Engine Sprocket
B. Holding Plate
C. Engine Sprocket Bolts

- Loosen the drive chain (see Drive Chain Slack Adjustment).
 - Holding Plate
 - Engine Sprocket
- Pull the engine sprocket off the output shaft with the drive chain, and remove the sprocket.

10-6 FINAL DRIVE

Engine Sprocket Installation

- Installation is the reverse of removal. Note the following.
- Install the engine sprocket with the protruding side facing in.

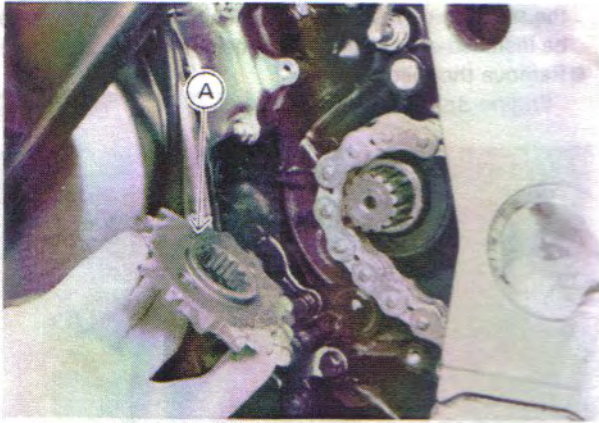

A. Protruding Side

- Torque the following (see Exploded View).
Engine Sprocket Bolts
- Adjust the following.
Drive Chain Slack



Brakes

Table of Contents

Exploded View	11-2	Inspection and Adjustment	
Specifications	11-4	after Installation	*
Special Tool	*	Front Master Cylinder	
Brake Adjustment	*	Disassembly Notes	*
Front Brake	*	Front Master Cylinder	
Rear Brake	*	Assembly Notes	*
Brake Pedal Position Inspection	*	Rear Master Cylinder	
Brake Pedal Position Adjustment	*	Disassembly Notes	*
Calipers	11-5	Rear Master Cylinder	
Caliper Removal	11-5	Assembly Notes	*
Caliper Installation Notes	*	Master Cylinder Inspection	
Caliper Disassembly Notes	*	(Visual Inspection)	*
Caliper Assembly Notes	*	Reservoir Removal	11-5
Fluid Seal Damage	*	Reservoir Installation Notes	*
Dust Seal and Cover Damage	*	Discs	
Piston Cylinder Damage	*	Disc Wear	*
Caliper Holder Shaft Wear	*	Disc Cleaning	*
Brake Pads	*	Disc Warp	*
Pad Removal	*	Brake Fluid	*
Pad Installation Notes	*	Fluid Level Inspection	*
Lining Wear	*	Brake Fluid Change	*
Master Cylinders	11-5	Bleeding the Brake Line	*
Front Master Cylinder Removal	*	Brake Hoses	*
Front Master Cylinder Installation Notes	*	Brake Hose Inspection	*
Rear Master Cylinder Removal	*	Brake Hose Replacement	*
Rear Master Cylinder Installation Notes	*		

* : Refer to Base Manual

Quick Reference

11-2 BRAKES

Exploded View

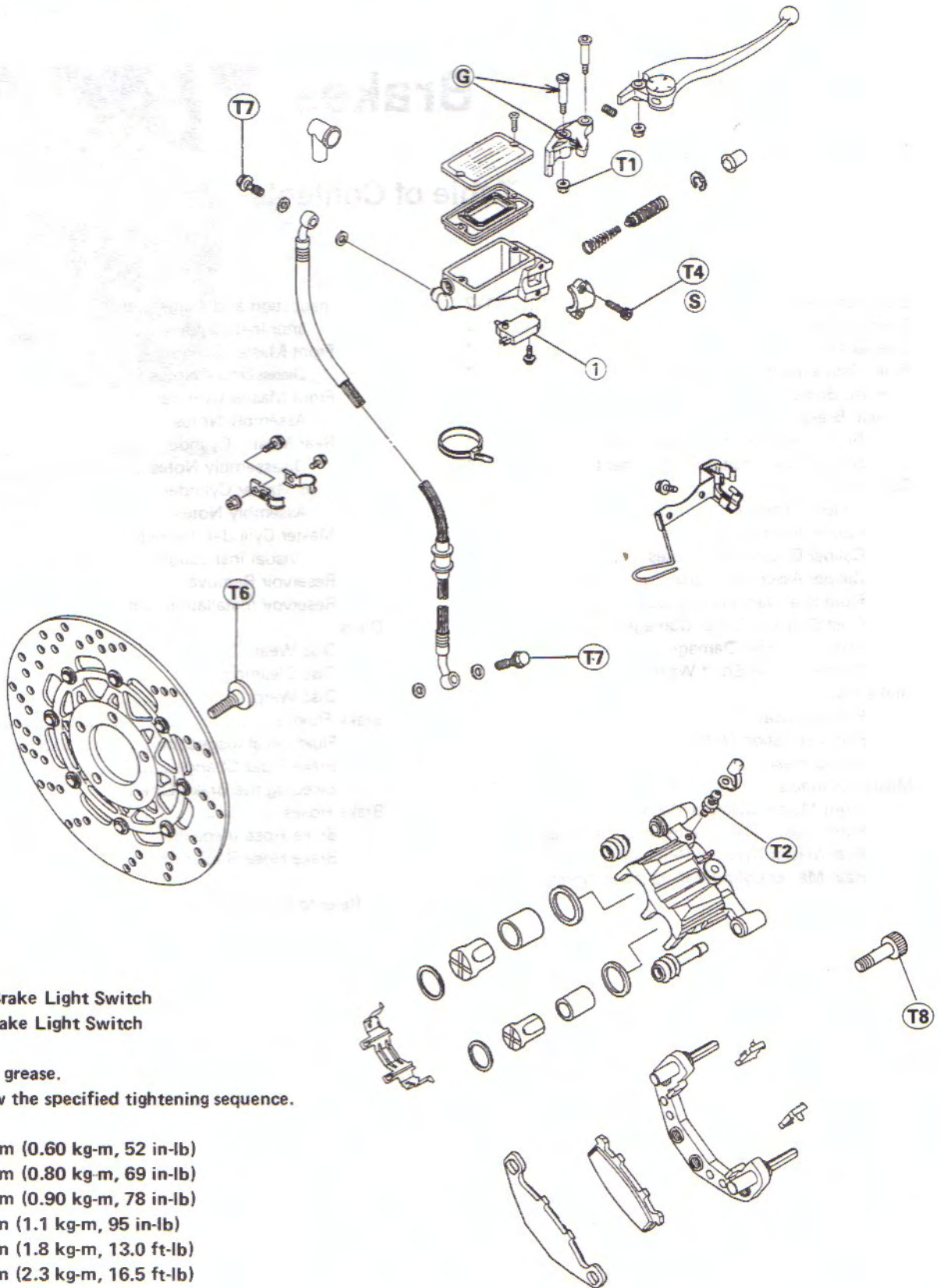

- 1. Front Brake Light Switch
- 2. Rear Brake Light Switch

G : Apply grease.
S : Follow the specified tightening sequence.

- T1: 5.9 N-m (0.60 kg-m, 52 in-lb)
- T2: 7.8 N-m (0.80 kg-m, 69 in-lb)
- T3: 8.8 N-m (0.90 kg-m, 78 in-lb)
- T4: 11 N-m (1.1 kg-m, 95 in-lb)
- T5: 18 N-m (1.8 kg-m, 13.0 ft-lb)
- T6: 23 N-m (2.3 kg-m, 16.5 ft-lb)
- T7: 25 N-m (2.5 kg-m, 18.0 ft-lb)
- T8: 32 N-m (3.3 kg-m, 24 ft-lb)

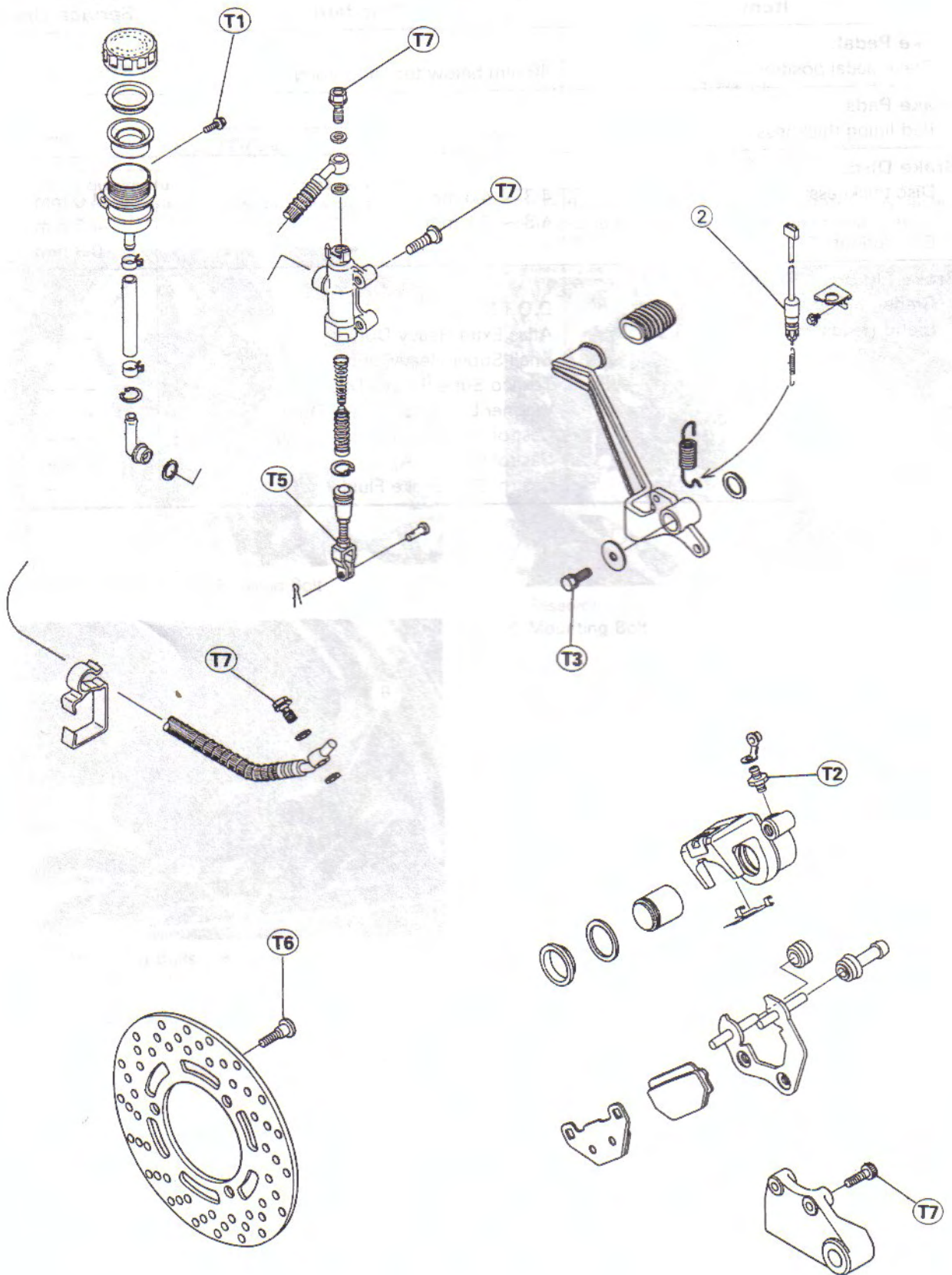

11-4 BRAKES

Specifications

Item	Standard	Service Limit
Brake Pedal: Brake pedal position	40 mm below top of footpeg	---
Brake Pads: Pad lining thickness	4.5 mm	1 mm
Brake Discs: Disc thickness: Front Rear Disc runout	4.3 ~ 4.6 mm 4.8 ~ 5.1 mm ---	4.0 mm 4.5 mm 0.3 mm
Brake Fluid: Grade Brand (recommended)	D.O.T.3 Atlas Extra Heavy Duty Shell Super Heavy Duty Texaco Super Heavy Duty Wagner Lockheed Heavy Duty Castrol Girling-Universal Castrol GT (LMA) Castrol Disc Brake Fluid	--- --- --- --- --- --- --- ---

Calipers

Caliper Removal

- Remove the following.
 - Brake Hose Banjo Bolt (at Caliper)
 - Caliper Mounting Bolts
 - Caliper

CAUTION

Brake fluid quickly ruins painted surfaces; any spilled fluid should be completely wiped up immediately.

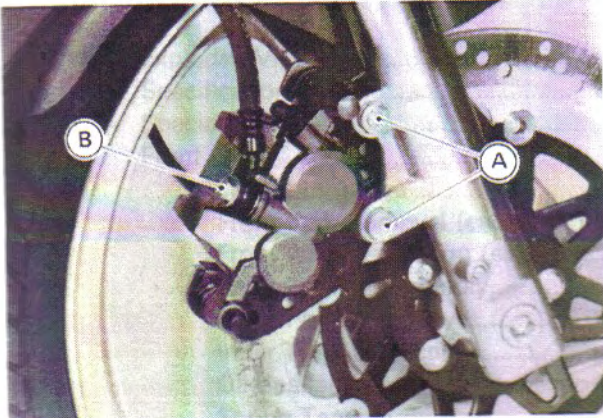

A. Caliper Mounting Bolts B. Banjo Bolt

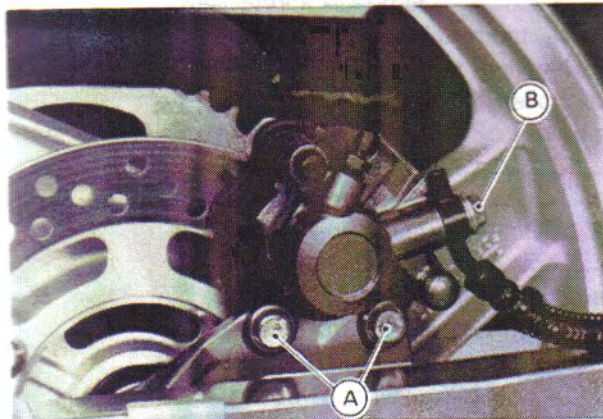

A. Caliper Mounting Bolts B. Banjo Bolt

Master Cylinders

Reservoir Removal

- Remove the following.
 - Right Side Cover
 - Reservoir Mounting Bolt
 - Brake Hose Clamp (at Reservoir)
 - Reservoir

CAUTION

Brake fluid quickly ruins painted surfaces; any spilled fluid should be completely wiped up immediately.

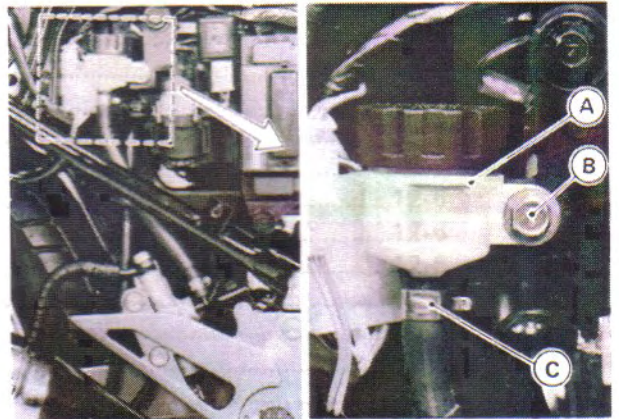

A. Reservoir
B. Mounting Bolt

C. Brake Hose Clamp

Suspension

Table of Contents

Exploded View	12-2
Specifications	12-3
Special Tools	12-4
Front Fork	12-5
Fork Oil Change	12-5
Front Fork Removal (each fork leg)	12-6
Front Fork Installation (each fork leg)	12-6
Front Fork Disassembly	12-6
Front Fork Assembly	12-7
Inner Tube Inspection	*
Oil Seal and Dust Seal Inspection	*
Spring Tension	*
Rear Suspension (Uni-trak)	12-8
Rear Shock Absorber	12-8
Spring Preload Adjustment	12-8
Rear Shock Absorber Removal	12-8
Rear Shock Absorber Installation	12-9
Rear Shock Absorber Scrapping	12-9
Swing Arm	12-9
Swing Arm Removal	12-9
Swing Arm Installation Note	12-9
Swing Arm Sleeve Inspection	*
Swing Arm Needle Bearing Inspection	*
Swing Arm Needle Bearing Lubrication	*
Tie-rods, Rocker Arm	12-9
Tie-rod Removal	*
Tie-rod Installation Note	*
Rocker Arm Removal	12-9
Rocker Arm Installation Notes	*
Tie-rod, Rocker Arm Bushing Inspection	*
Tie-rod, Rocker Arm Sleeve Inspection	*
Tie-rod, Rocker Arm Bushing Lubrication	*

* : Refer to Base Manual

Quick Reference

12-2 SUSPENSION

Exploded View

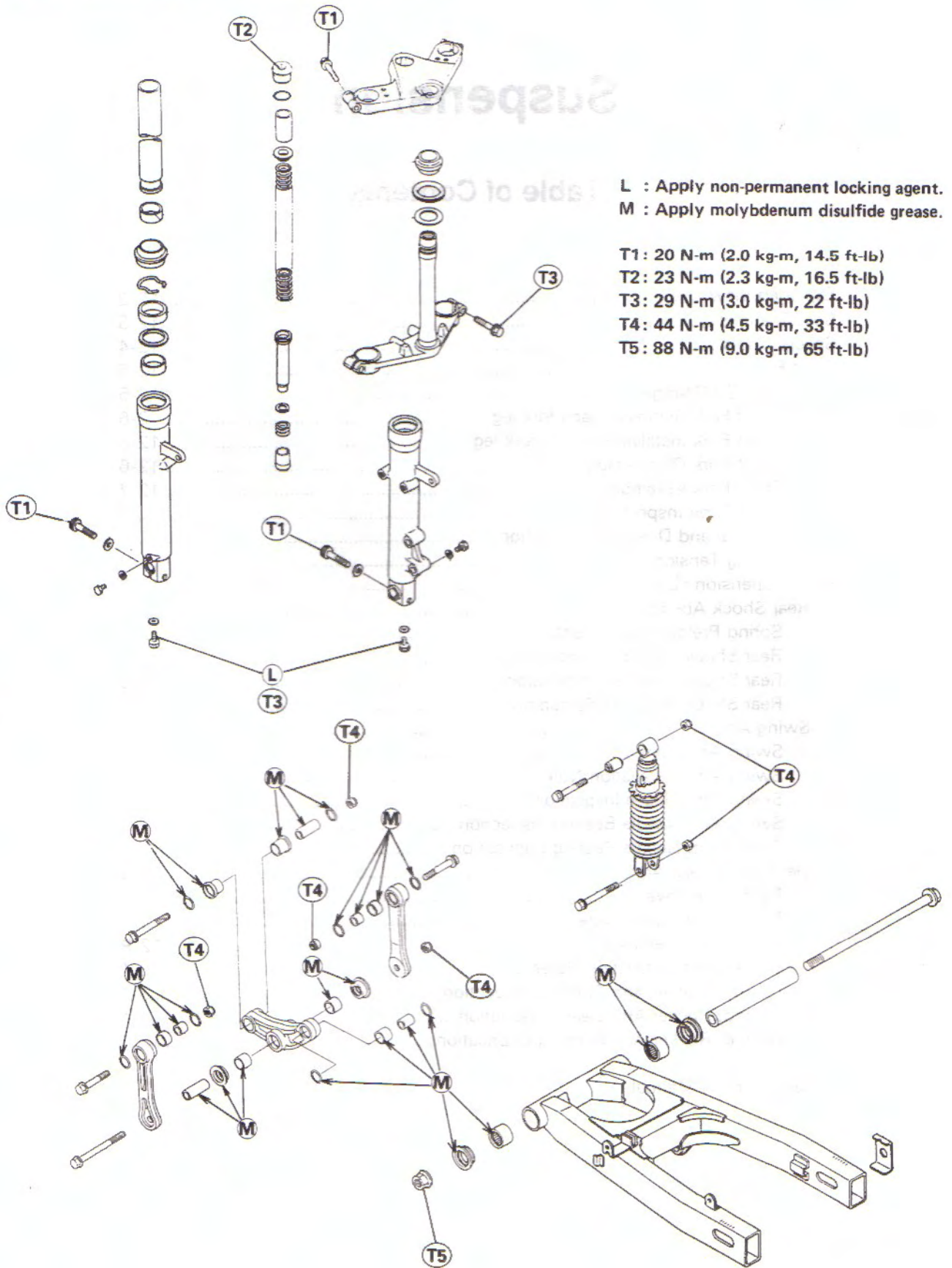

Specifications

Item	Standard	Service Limit
Front Fork:		
Fork oil:		
Viscosity	SAE 10W-20	---
Amount per unit	350 ± 4 mL	---
Fork oil level	300 mL: When changing oil 135 ± 2 mm (Fully compressed, without spring)	---
Fork spring free length	415 mm	407 mm
Rear Suspension:		
Rear shock absorber spring preload adjustment	2nd position	1 ~ 5
Rear shock absorber gas pressure (non-adjustable)	980 kPa (10 kg/cm ² , 142 psi)	---

12-4 SUSPENSION

Special Tools

Fork Cylinder Holder Handle: 57001-183

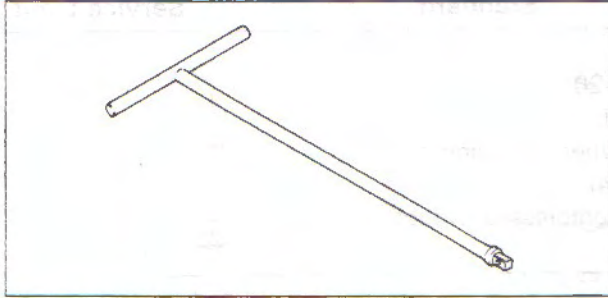

Fork Outer Tube Weight: 57001-1218

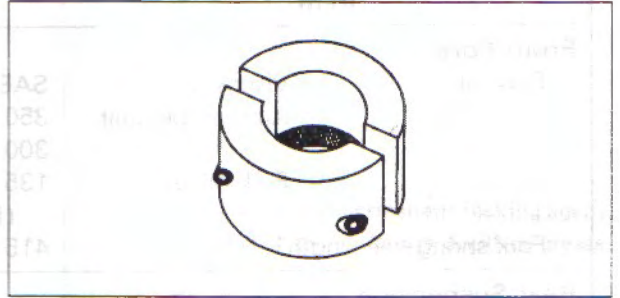

Fork Cylinder Holder Adapter: 57001-1057

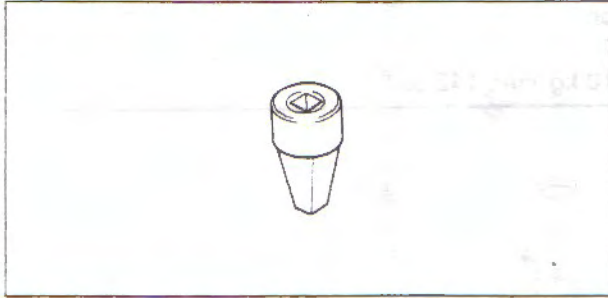

Fork Oil Seal Driver: 57001-1219

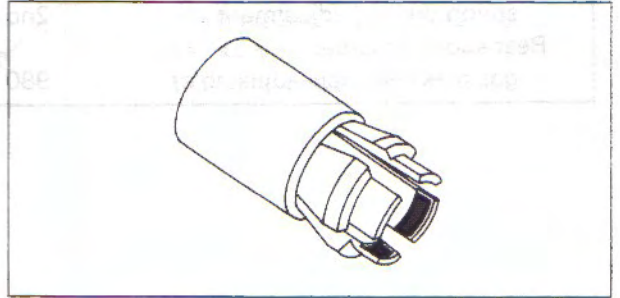

Oil Seal & Bearing Remover: 57001-1058

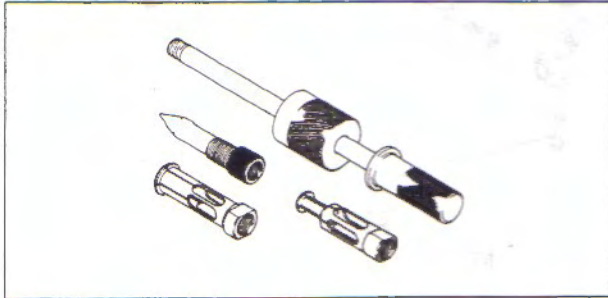

Oil Syringe: 57001-1290

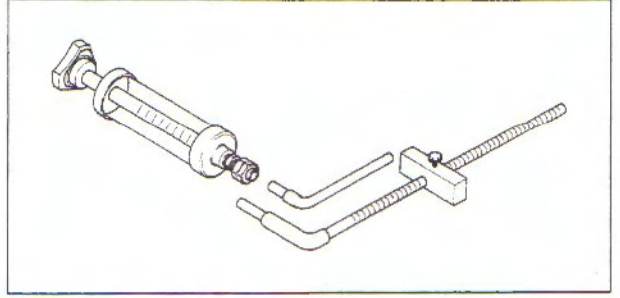

Steering Stem Nut Wrench: 57001-1100



Bearing Driver Set: 57001-1129



Front Fork

Fork Oil Change

- Remove the following.
 - Drain Screw (left or right fork leg)
- Allow the oil to drain into a suitable container. If you pump the fork legs to force out the oil, be sure to catch the oil in a container as it squirts out.

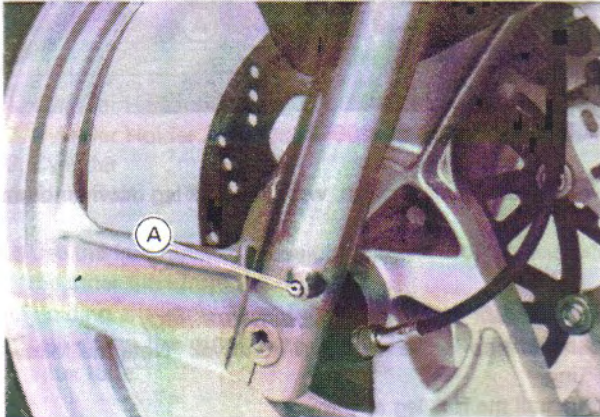

A. Drain Screw

- Raise the front wheel off the ground.
- Remove the following.
 - Handlebar Holders

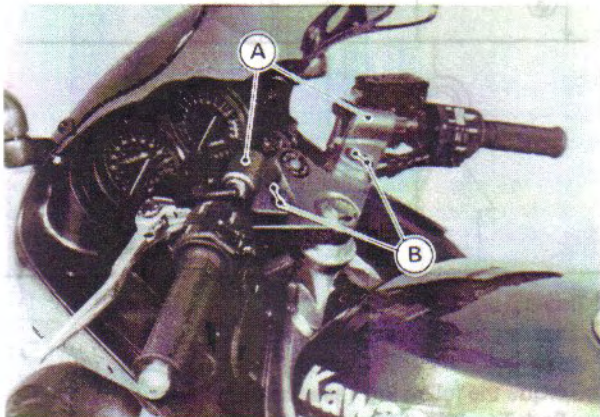

A. Handlebar Holders B. Holder Bolts

Fork Upper Clamp Bolts (loosen)
Fork Top Plugs

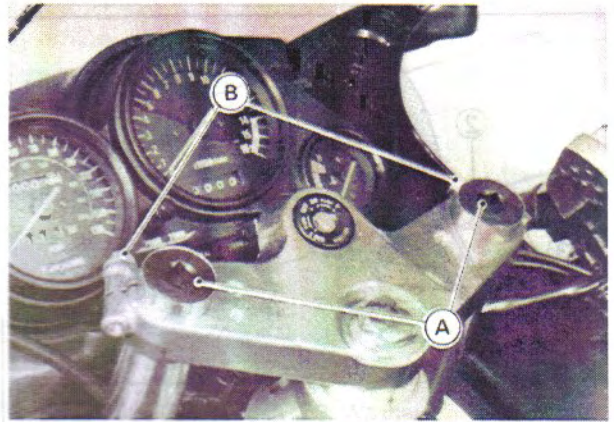

A. Top Plugs B. Upper Clamp Bolts

- Spacers
- Spring Seats
- Main Springs
- Wash the drain screw threads clean of oil, and blow them dry.
- Apply a non-permanent locking agent to the following.
 - Drain Screw Threads
- Install the drain screw with a new gasket.
- Pour in the type and amount of fork oil specified.

Front Fork Oil

Viscosity: **SAE 10W-20**

Amount per side:

When changing oil: **approx. 300 mL**

After disassembly and completely dry:
350 ± 4 mL

- ★ If necessary, measure the oil level as following.
 - Slowly compress the front fork fully by pushing up the outer tubes using a jack or other suitable means under the front wheel.
 - Wait until the oil level settles.
 - Insert a tape measure or rod into the inner tube, and measure the distance from the top of the inner tube to the oil.

NOTE

- Fork oil level may also be measured using the oil syringe (special tool).
- The tape measure, rod, or oil syringe pipe should be in the middle of the inner tube, or the correct oil level can not be measured.
- Set the oil syringe stopper so that its lower side shows the oil level distance specified.
- Put the gauge tube into the inner tube and position the stopper across the top end of the inner tube.

12-6 SUSPENSION

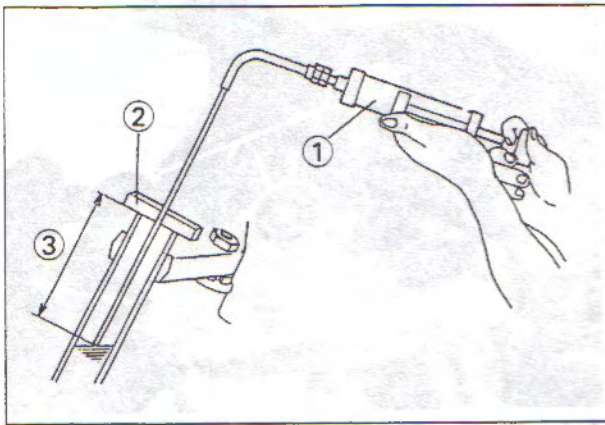

1. Oil Syringe: 57001-1290
 2. Stopper
 3. Oil Level Distance

NOTE

- The gauge tube is graduated in 1 cm division.
- The syringe body is graduated in 10 mL divisions, excluding the gauge tube which is about 5 mL capacity.
- Pull the handle slowly to draw out the excess oil until no more oil comes up the tube.
- ★ If no oil is drawn out, there is not enough oil in the inner tube. Pour in some more oil, then draw out the excess.

Fork Oil Level

(Fully compressed without spring)

135 ±2 mm

- ★ If the oil is above or below the specified level, remove or add oil and recheck the oil level.
- Change the oil of the other fork leg in the same manner.
- Install the parts removed.
- Torque the following (see Exploded View).
 - Fork Top Plugs
 - Fork Upper Clamp Bolts
 - Handlebar Holder Bolts

Front Fork Removal (each fork leg)

- Loosen the fork top plug beforehand if the fork leg is to be disassembled.
- Remove the following.
 - Handlebar Holder
 - Brake Caliper (right fork leg)
 - Front Wheel
 - Front Fender
 - Lower Fairing
- Remove the clamps and free the electrical wirings, brake hose, or speedometer cable from the fork leg.
- Remove the following.
 - Fork Clamp Bolts (upper and lower, loosen)

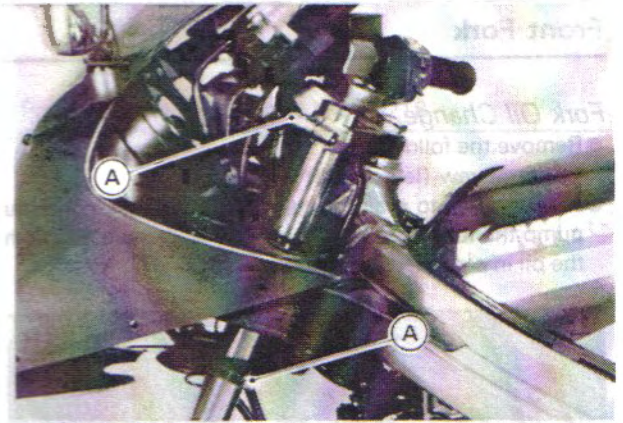

A. Fork Clamp Bolt

- With a twisting motion, work the fork leg down and out.

Front Fork Installation (each fork leg)

- Installation is the reverse of removal. Note the following.
- Install the fork leg as shown.

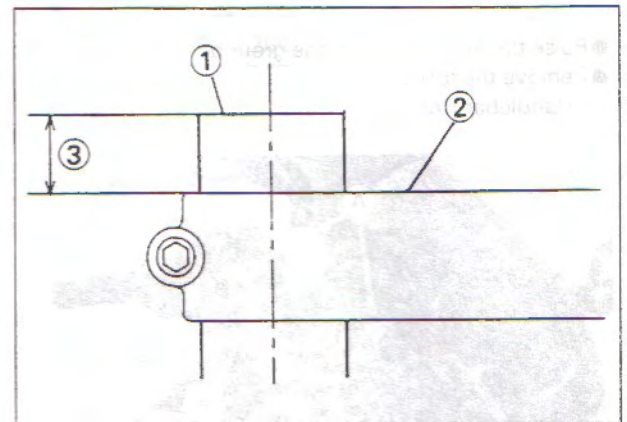

1. Inner Tube Top 3.12 mm
 2. Steering Stem Head Surface

- Torque the following (see Exploded View).
 - Fork Top Plug (if loosened)
 - Fork Clamp Bolts
 - Handlebar Holder Bolts

Front Fork Disassembly

- Remove the following.
 - Fork Oil (drain)
 - Fork Leg
 - Fork Top Plug
 - Spacer
 - Spring Seat
 - Main Spring
 - Dust Seal
 - Retainer
- Stop the cylinder from turning by using the front fork cylinder handle and adapter (special tools).

- Unscrew the Allen bolt, then take the bolt and gasket out of the bottom of the outer tube.

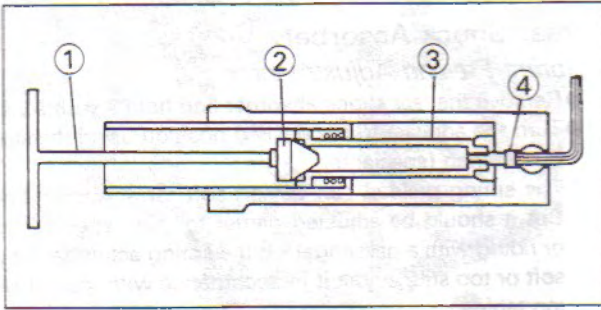

1. Cylinder Holder Handle: 57001-183
2. Cylinder Holder Adapter: 57001-1057
3. Cylinder
4. Allen Bolt

- Use the fork outer tube weight (special tool) to separate the inner tube from the outer tube.
- Holding the inner tube by hand in a vertical position, pull down the outer tube several times to pull out the inner tube.

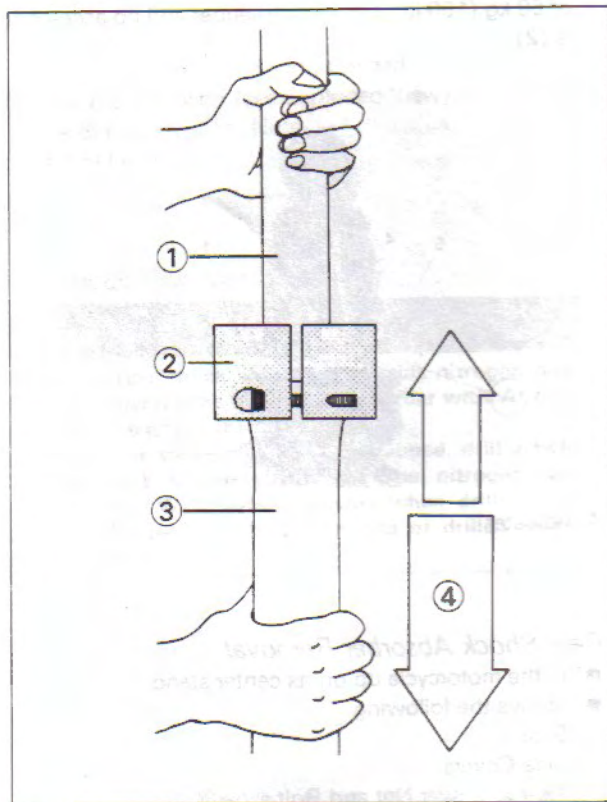

1. Inner Tube
2. Weight: 57001-1218
3. Outer Tube
4. Pull down.

- The oil seal, washer, and guide bushes come off with the inner tube

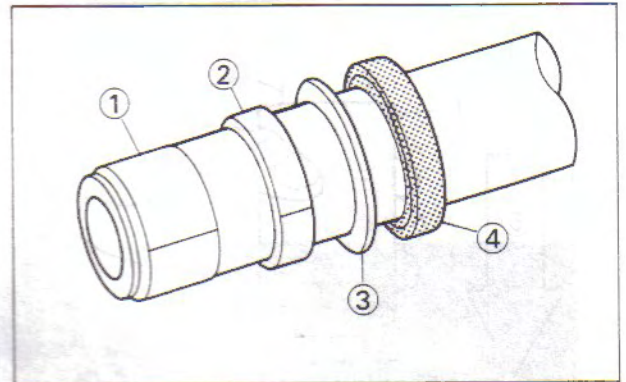

1. Inner Tube Guide Bush
2. Outer Tube Guide Bush
3. Washer
4. Oil Seal

Front Fork Assembly

- Assembly is the reverse of disassembly. Note the following.
- Check the top plug O-ring and replace it with a new one if necessary.
- Replace the following parts removed with a new one.
 - Guide Bushes
 - Oil Seal
 - Bottom Allen Bolt Gasket
- Install the cylinder base so that the small diameter end of it comes to the cylinder.

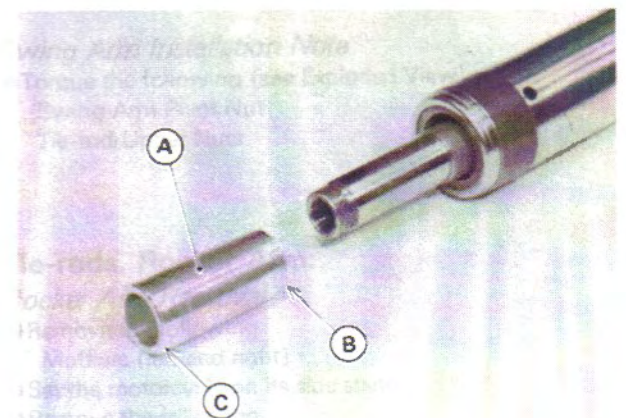

- A. Cylinder Base
- B. Small Diameter End
- C. Large Diameter End

- Apply a non-permanent locking agent to the following.
 - Bottom Allen Bolt Threads
- Torque the following (see Exploded View).
 - Bottom Allen Bolt
 - Fork Top Plug (after fork leg installation)
- Install the guide bush (with a used guide bush on it) by tapping the used guide bush with the fork oil seal driver (special tool) until it stops. The split of the bush must be faced toward the side of the vehicle.

12-8 SUSPENSION

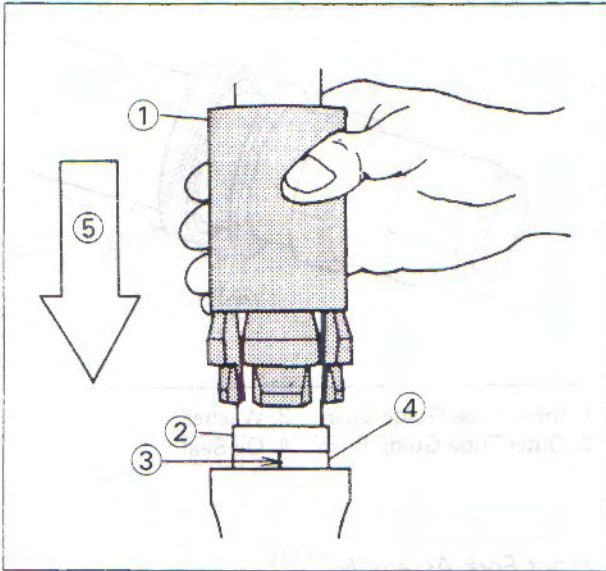

1. Driver: 57001-1219 4. New Guide Bush
 2. Used Guide Bush 5. Tap
 3. Split (toward the right or left)

Rear Suspension (Uni-trak)

Rear Shock Absorber:

Spring Preload Adjustment

- Remove the rear shock absorber and hold it with a vise.
- Turn the adjuster to the desired position using the stem nut wrench (special tool).
- The spring preload can be left soft for average riding. But it should be adjusted harder for high speed riding or riding with a passenger. If the spring action feels too soft or too stiff, adjust it in accordance with the following table.

Spring Preload Adjustment

Adjuster Position	Spring Force	Setting	Load	Road	Speed
1 ↓ 5	Weak ↓ Strong	Soft ↓ Hard	Light ↓ Heavy	Good ↓ Bad	Low ↓ High

- The standard adjuster setting for an average-build rider of 68 kg (150 lb) with no passenger and no accessories is (2).

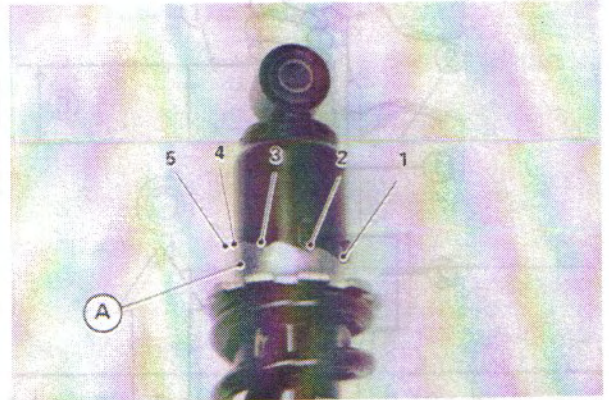

A. Adjuster

Rear Shock Absorber Removal

- Set the motorcycle up on its center stand.
- Remove the following.
 - Seat
 - Side Covers
 - Tie-rod Lower Nut and Bolt
 - Rear Shock Absorber Nuts and Bolts
- Support the rear wheel to remove the bolts.

CAUTION

When pulling out the bolts, lift the rear wheel slightly. Forcing or tapping on a bolt could damage the bolt, sleeve, and bearing.

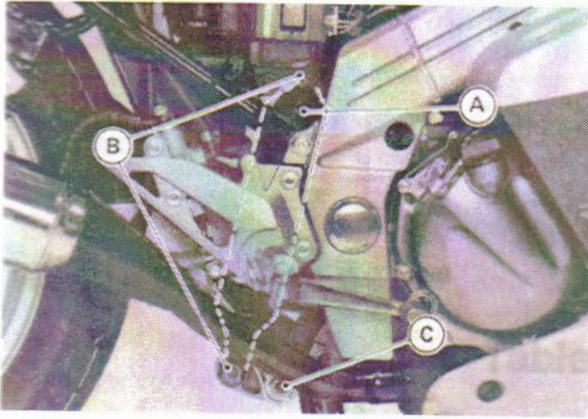

- A. Rear Shock Absorber
- B. Rear Shock Absorber Nuts
- C. Tie-rod Lower Nut

Rear Shock Absorber

Rear Shock Absorber Installation

- Installation is the reverse of removal. Note the following.
 - Adjust the following.
 - Rear Shock Absorber Spring Preload
 - Torque the following (see Exploded View).
 - Rear Shock Absorber Nuts
 - Tie-rod Lower Nut

Rear Shock Absorber Scrapping

⚠ WARNING

Since the rear shock absorber contains nitrogen gas, do not incinerate the rear shock absorber without first releasing the gas or it may explode.

Before a rear shock absorber is scrapped, drill a hole at the point shown to release the nitrogen gas completely. Wear safety glasses when drilling the hole, as the gas may blow out bits of drilled metal when the hole opens.

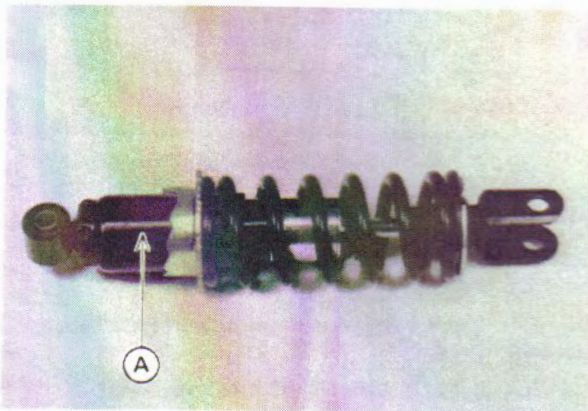

- A. Drill this point.

Swing Arm:

Swing Arm Removal

- Remove the following.
 - Rear Wheel
 - Rear Shock Absorber
 - Drive Chain Cover
 - Swing Arm Pivot Nut

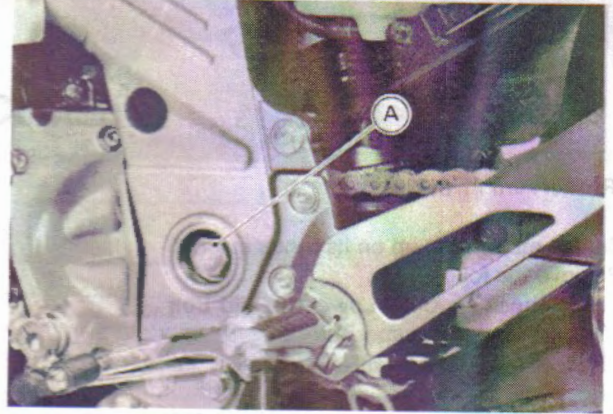

- A. Swing Arm Pivot Nut

Swing Arm Pivot Shaft
Swing Arm

- Remove the following from the swing arm.
 - Tie-rods

Swing Arm Installation Note

- Torque the following (see Exploded View).
 - Swing Arm Pivot Nut
 - Tie-rod Upper Nuts

Tie-rods, Rocker Arm:

Rocker Arm Removal

- Remove the following.
 - Mufflers (left and right)
- Set the motorcycle on its side stand.
- Remove the following.
 - Rocker Arm Pivot Nut
- Do not remove the rocker arm pivot shaft.

12-10 SUSPENSION

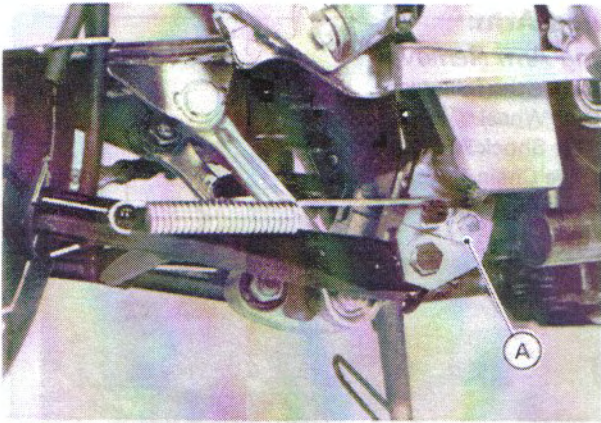

A. Rocker Arm Pivot Nut

- Set the motorcycle up on its center stand.
- Remove the following.
 - Rear Shock Absorber Lower Nut and Bolt
 - Tie-rod Lower Nut and Bolt
 - Rocker Arm Pivot Shaft
 - Rocker Arm
- Support the rear wheel to remove the bolts.

CAUTION

When pulling out the bolts, lift the rear wheel slightly. Forcing or tapping on a bolt could damage the bolt, sleeve, and bearing.

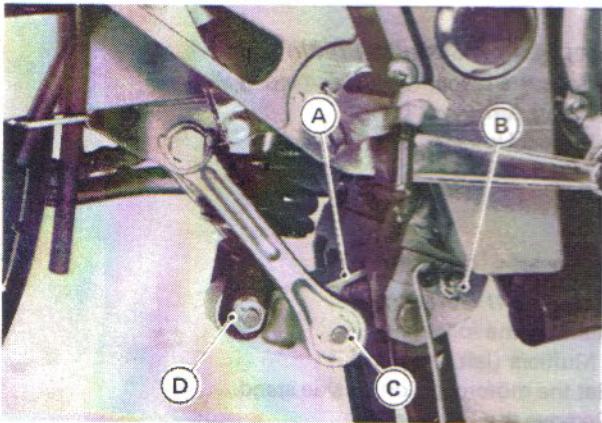

- A. Rocker Arm
- B. Rocker Arm Pivot Shaft
- C. Tie-rod Lower Nut
- D. Rear Shock Absorber Lower Nut

Steering

Table of Contents

Exploded View	13-2
Special Tools	13-3
Steering Adjustment	*
Steering Inspection	*
Steering Adjustment	*
Steering Removal/Installation	*
Steering Stem Removal	*
Steering Stem Installation	*
Steering Maintenance	*
Steering Stem Bearing Lubrication	*
Bearing Wear, Damage	*
Grease Seal Deterioration, Damage	*
Steering Stem Warp	*

* : Refer to Base Manual

Quick Reference

13-2 STEERING

Exploded View

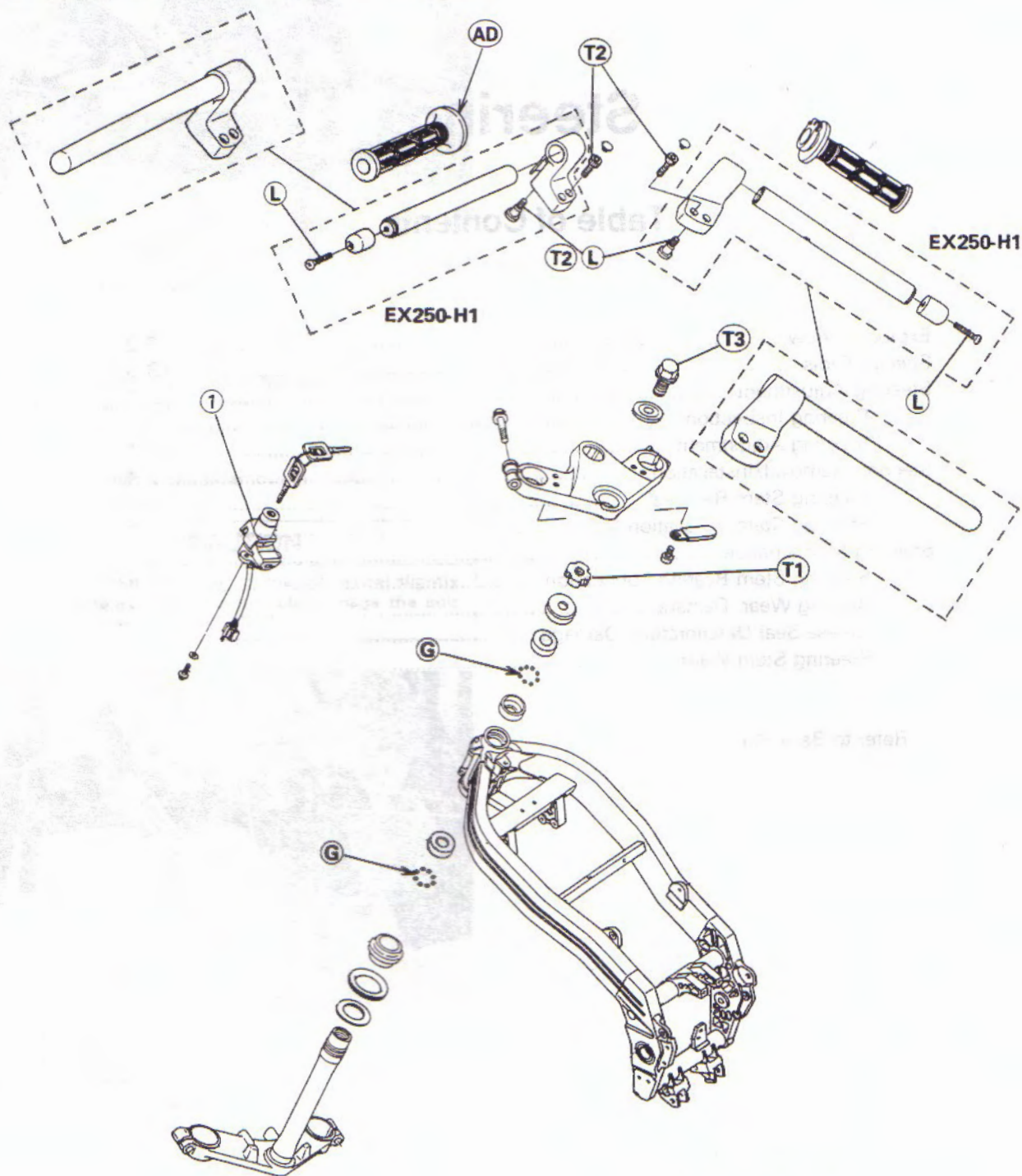

1. Ignition Switch

AD : Apply adhesive agent.

G : Apply grease.

L : Apply non-permanent locking agent.

T1: 7.4 N-m (0.75 kg-m, 65 in-lb)

T2: 23 N-m (2.3 kg-m, 16.5 ft-lb)

T3: 47 N-m (4.8 kg-m, 35 ft-lb)

Special Tools

Stem Bearing Driver: 57001-137

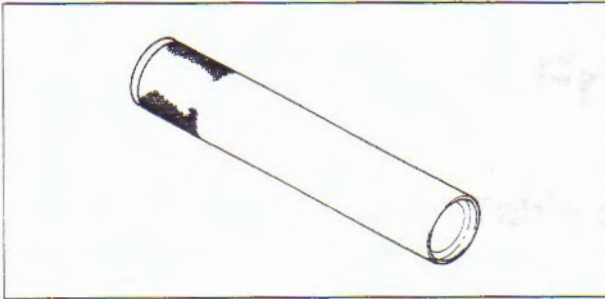

Bearing Driver Set: 57001-1129



Bearing Puller: 57001-158

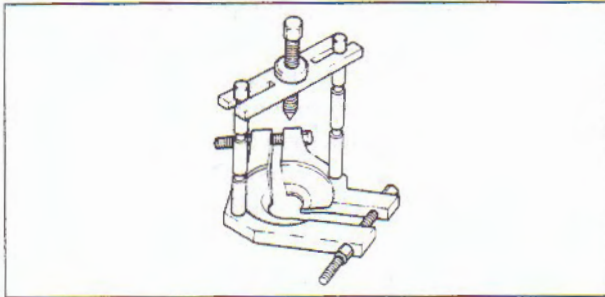

Stem Bearing Driver Adapter: 57001-294

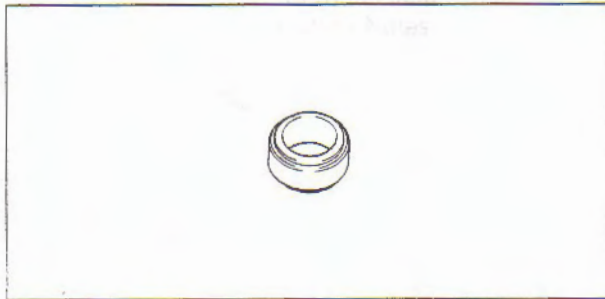

Bearing Puller Adapter: 57001-317



Steering Stem Nut Wrench: 57001-1100



Frame

Table of Contents

Exploded View	14-2
Fairings	14-5
Upper Fairing Removal	14-5
Inner Fairing Removal	14-5
Lower Fairing Removal	14-5
Side Covers	14-6
Removal	14-6
Fenders	14-7
Rear Fender Removal	14-7
Rear Frame	14-8
Removal	14-8
Installation Notes	14-8

Quick Reference

14-2 FRAME

Exploded View

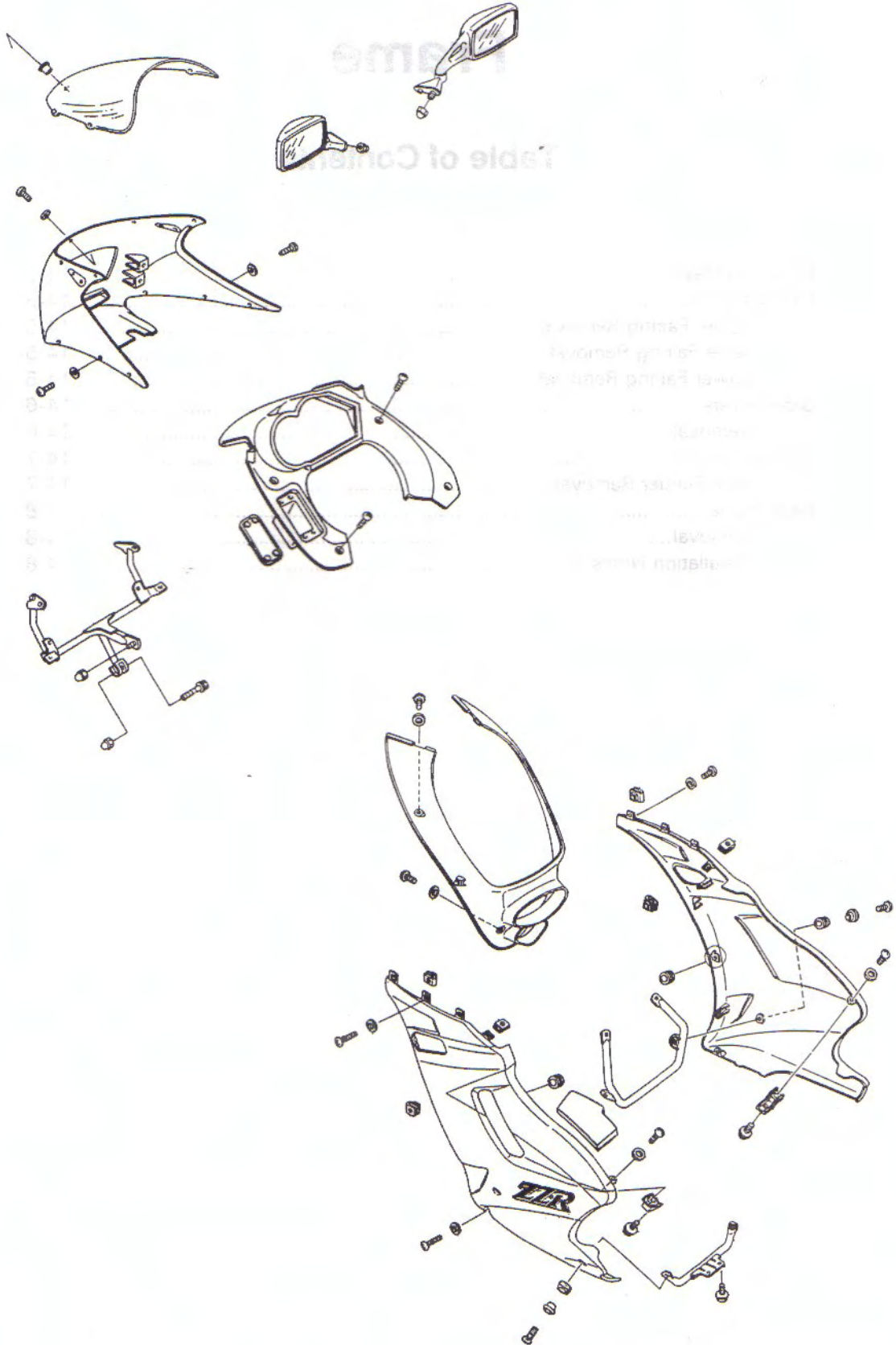

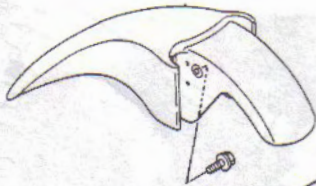
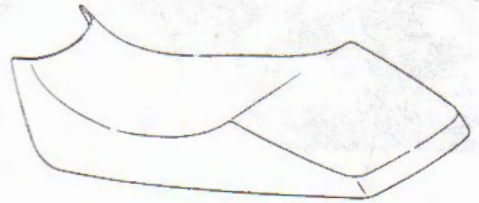
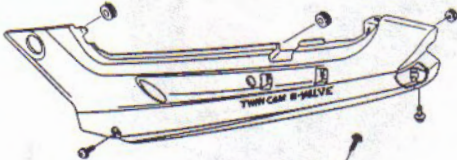
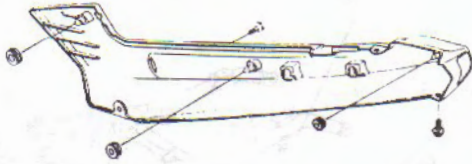

- (AS): Austria Model
- (F) : Finland Model
- (G) : Greece Model
- (S) : Switzerland Model

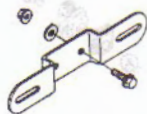
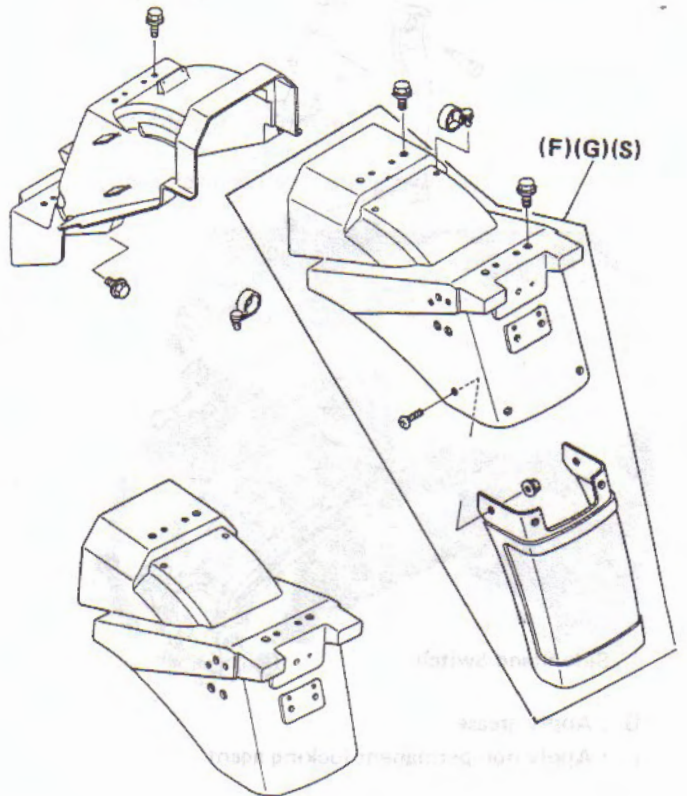
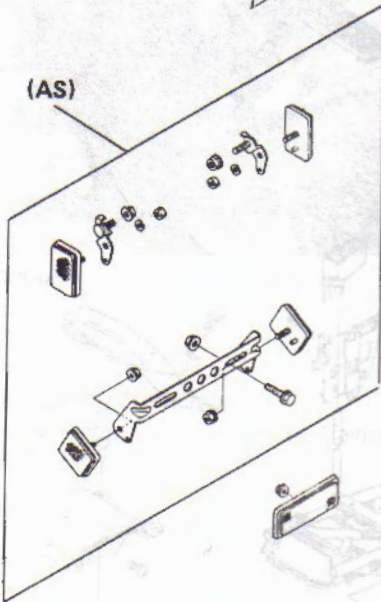

14-4 FRAME

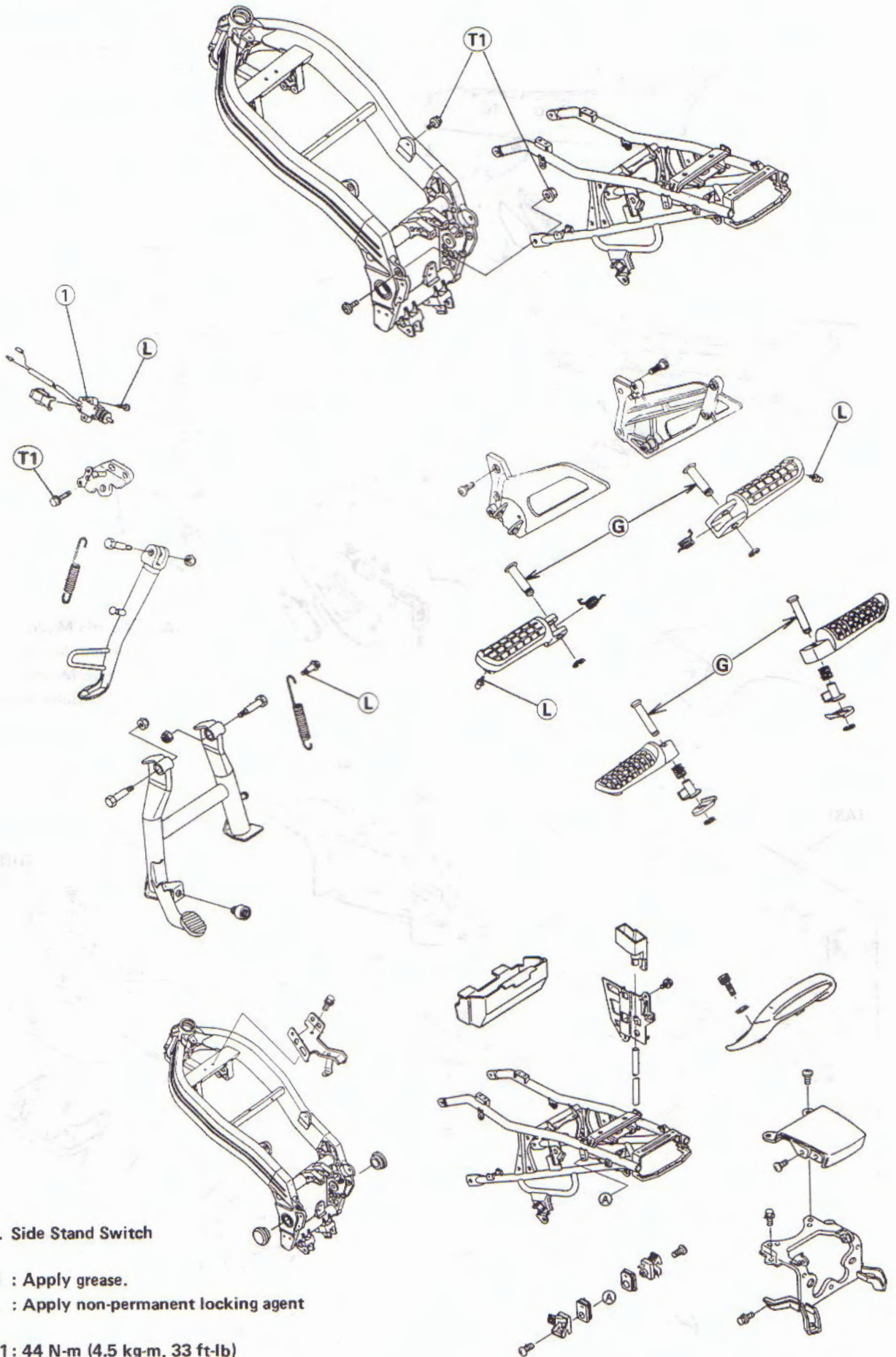

1. Side Stand Switch

G : Apply grease.

L : Apply non-permanent locking agent

T1: 44 N-m (4.5 kg-m, 33 ft-lb)

Fairings

Upper Fairing Removal

- Remove the following.
 - Rear View Mirrors (left and right)
 - Upper Fairing

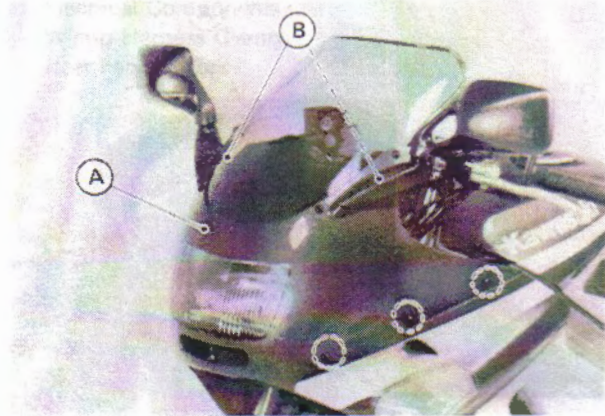

A. Upper Fairing B. Mirror Mounting Nuts

- Pull the upper fairing forward with bending the fairing outward, and free the fairing holes from the stopper on the bracket.

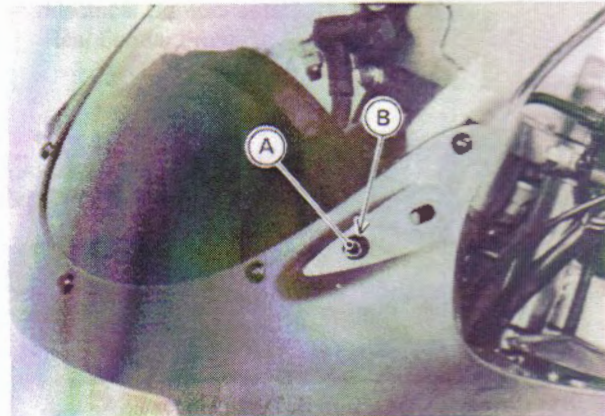

A. Stopper B. Hole

Inner Fairing Removal

- Before removing the inner fairing, remove the windshield.

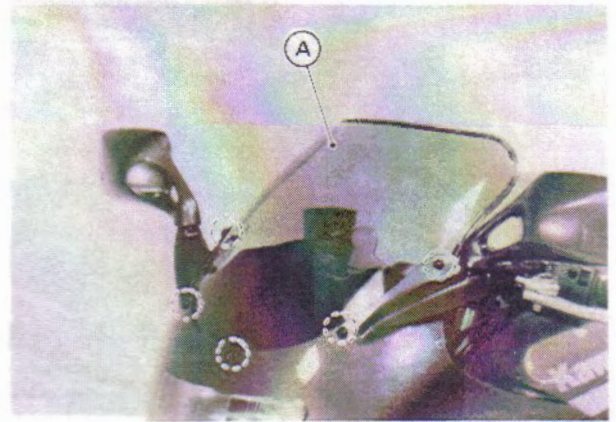

A. Windshield

- Remove the following.
 - Inner Fairing



A. Inner Fairing

Lower Fairing Removal

- Remove the following.
 - Lower Fairings (left, right, and front)

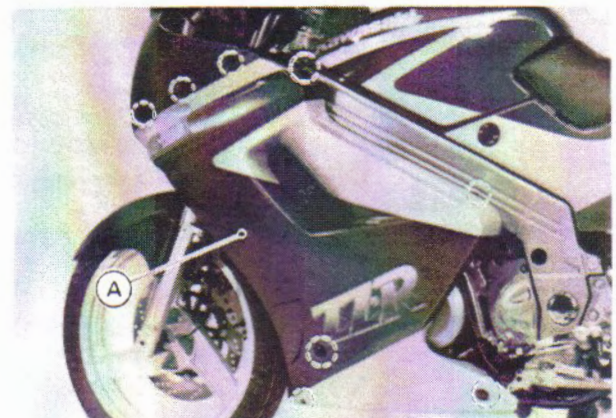

A. Lower Fairing (left)

14-6 FRAME

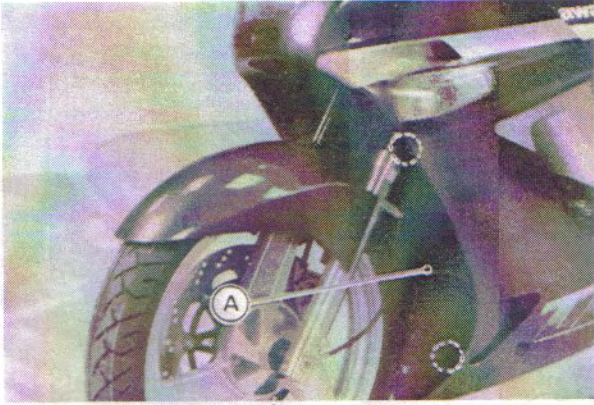

A. Lower Fairing (front)

Side Covers

Removal

- Remove the following.
 - Seat
 - Passenger's Grab Rail

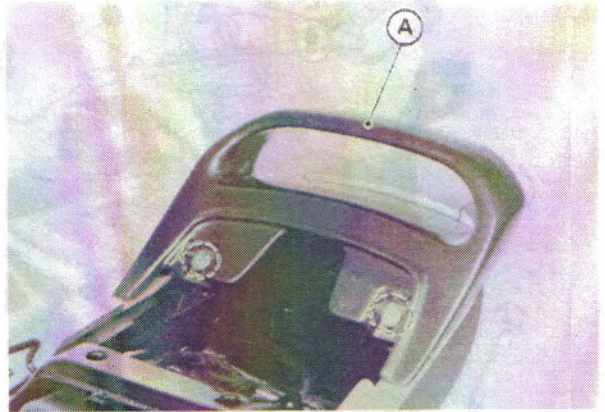

A. Grab Rail

Tying Hooks Side Covers

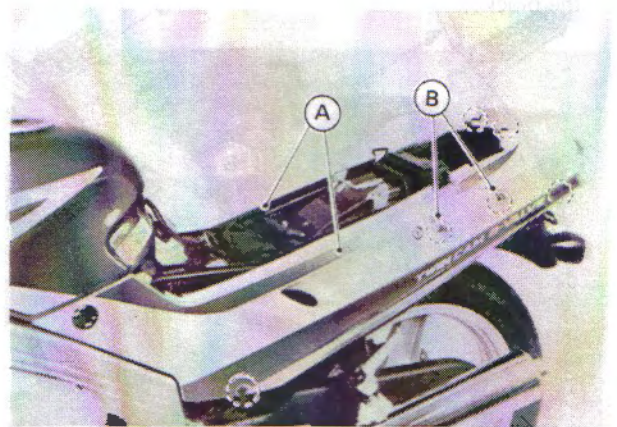

A. Side Covers

B. Tying Hooks

Fenders

Rear Fender Removal

- Remove the following.
 - Seat
 - Side Covers
 - Tail/Brake Light Bracket
 - Electrical Components
 - Wiring Harness Clamps
 - Rear Fender Rear

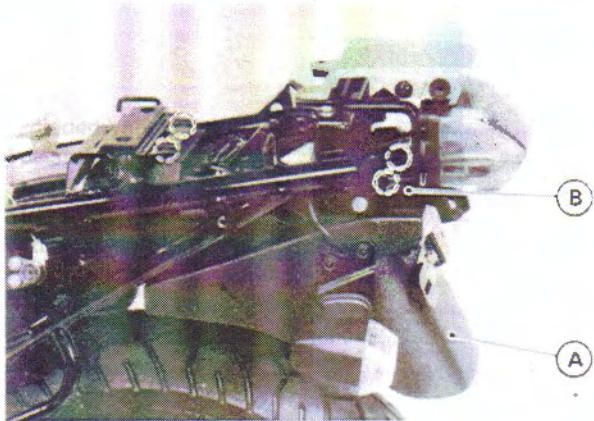

A. Rear Fender Rear B. Tail/Brake Light Bracket

Electrical Components Rear Fender Front

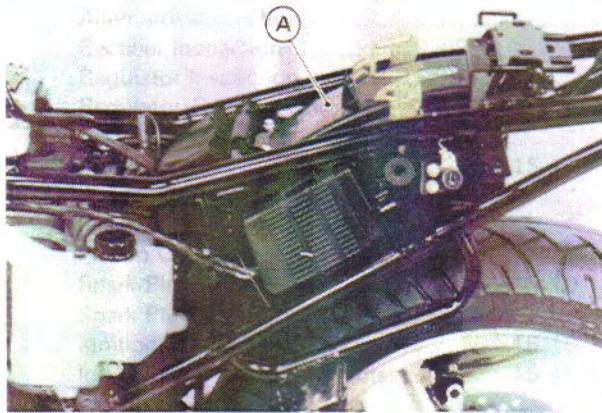

A. Rear Fender Front

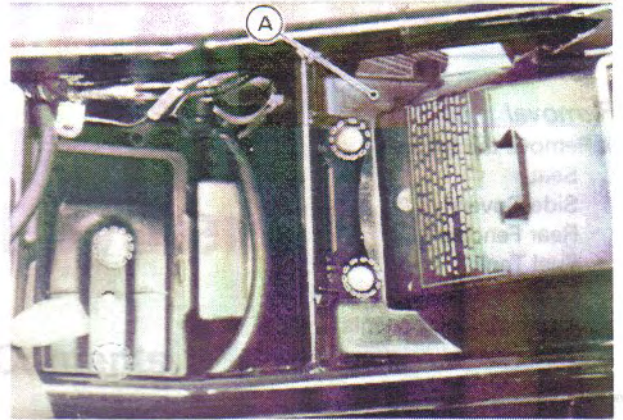

A. Rear Fender Front

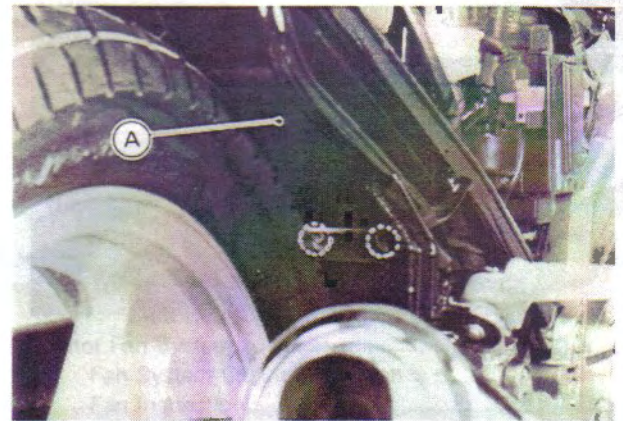

A. Rear Fender Front

14-8 FRAME

Rear Frame

Removal

- Remove the following.
 - Seat
 - Side Covers
 - Rear Fenders
 - Fuel Tank
 - Coolant Reservoir Tank
 - Electrical Components
 - Rear Frame

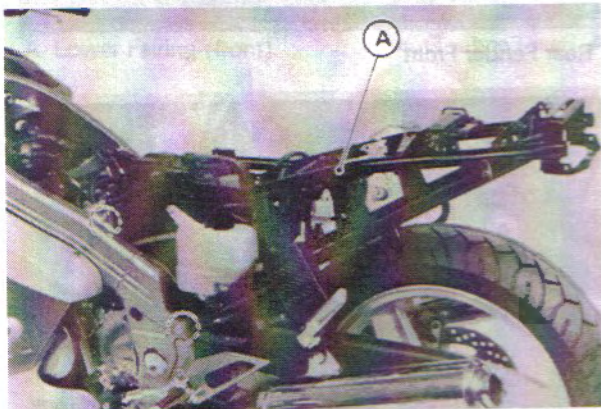

A. Rear Frame

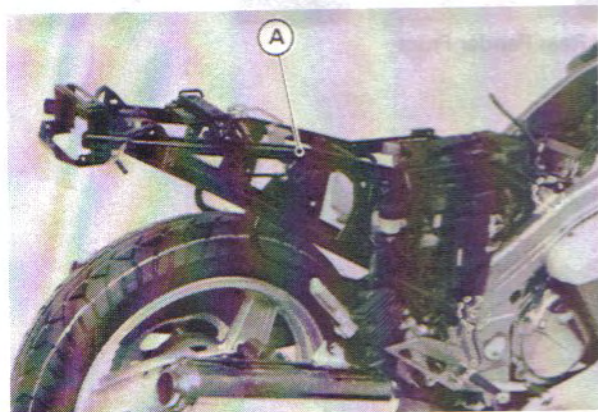

A. Rear Frame

Installation Notes

- Pushing the rear frame down, tighten the rear frame mounting bolts and nuts.
- Torque the following (see Exploded View).
 - Rear Frame Mounting Bolts
 - Rear Frame Mounting Nuts

Electrical System

Table of Contents

Exploded View	15-2	Lighting System	15-12
Specifications	15-5	Headlight Beam	
Special Tools	15-6	Horizontal Adjustment	*
Sealant	15-6	Headlight Beam Vertical Adjustment	*
Parts Location	15-7	Headlight Bulb Replacement Notes	*
Precautions	*	Tail/Brake Light Bulb	
Battery	15-20	Replacement Note	*
Charging Condition Inspection	15-20	Tail/Brake Light Lens Removal/	
Refreshing Charge	15-20	Installation Note	*
Charging System	15-8	Turn Signal Light	
Alternator Cover Removal	*	Bulb Replacement	15-12
Alternator Cover Installation Note	15-8	Radiator Fan System	15-12
Alternator Rotor Removal	15-8	Fan System Circuit Inspection	15-12
Alternator Rotor Installation Notes	*	Fan Inspection	15-12
Stator Coil Removal	*	Meters and Gauge	15-13
Stator Coil Installation Notes	15-8	Meter Removal	15-13
Alternator Inspection	*	Meter Installation Note	15-14
Rectifier Inspection	*	Bulb Replacement Notes	*
Regulator Inspection	*	Tachometer Inspection	15-14
Regulator/Rectifier Output		Water Temperature Gauge	
Voltage Inspection	*	Operation Inspection	*
Ignition System	15-10	Switches and Sensor	15-16
Safety Instructions	*	Front Brake Light Testing	*
Pickup Coil Removal	*	Rear Brake Light Testing	*
Pickup Coil Installation Note	15-10	Rear Brake Light Switch	
Spark Plug Removal	15-10	Position Adjustment	*
Spark Plug Installation Note	*	Switch Inspection	15-16
Ignition Coil Removal	15-10	Fan Switch Inspection	15-17
Ignition Coil Installation Notes	15-10	Water Temperature	
Pickup Coil Inspection	*	Sensor Inspection	*
Ignition Coil Inspection	15-10	Junction Box	15-17
Spark Plug Cleaning Inspection	*	Fuse Circuit Inspection and	
Spark Plug Gap	*	Replacement	15-17
IC Igniter Inspection	15-10	Starter / Headlight Circuit Relay	
Electric Starter System	15-11	Inspection	15-18
Starter Motor Removal	*	Diode Circuit Inspection	*
Starter Motor Installation Notes	*	Electrical Wiring	*
Starter Motor Disassembly	*	Wiring Inspection	*
Starter Motor Assembly	*	EX250H Wiring Diagram	15-23
Brush Inspection	*		
Brush Spring Inspection	*		
Commutator Cleaning and Inspection	*		
Armature Inspection	*		
Brush Lead Inspection	*		
Brush Plate and			
Terminal Bolt Inspection	*		
Starter Relay Inspection	*		

* : Refer to Base Manual

Quick Reference

15-2 ELECTRICAL SYSTEM

Exploded View

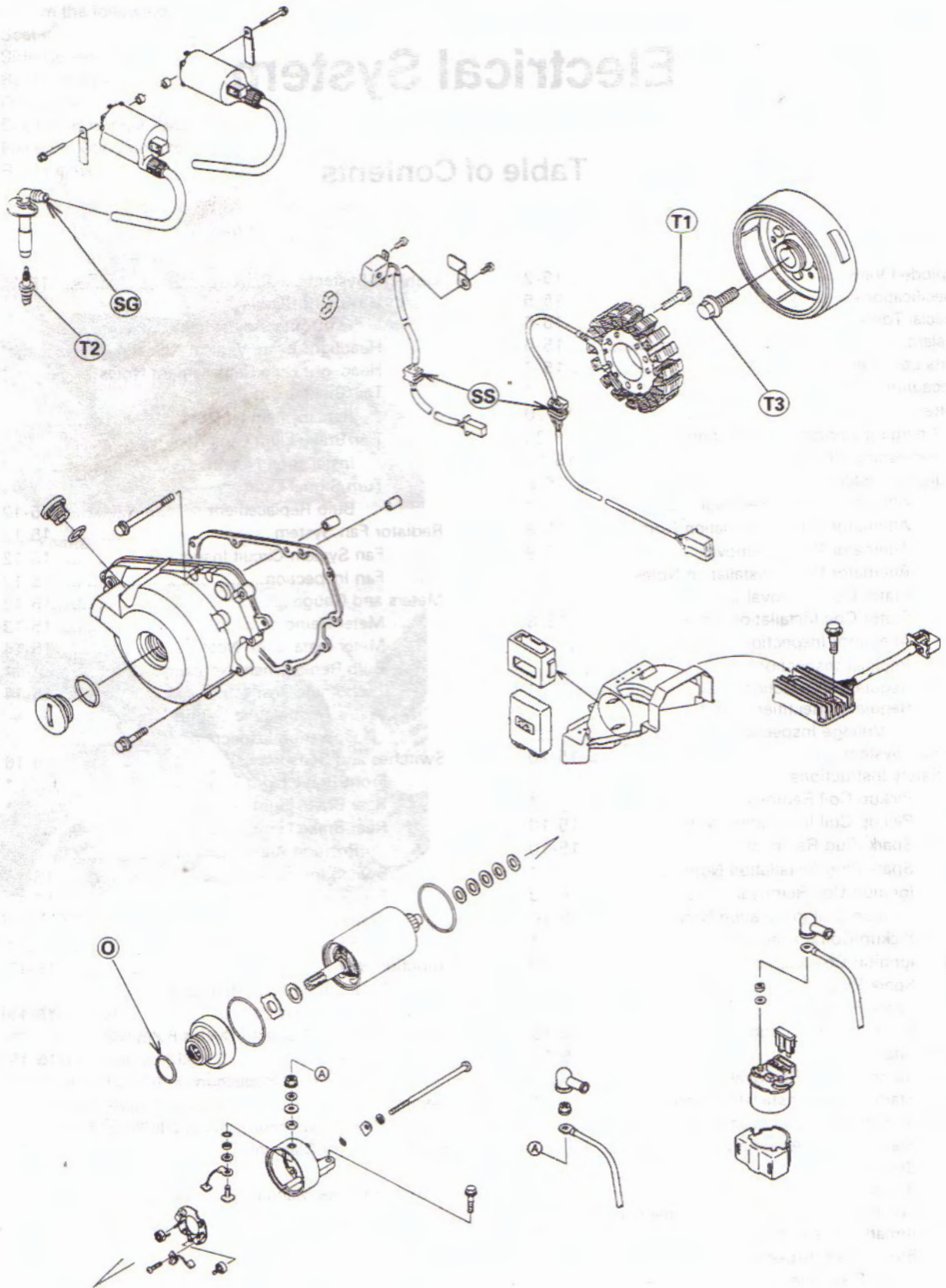

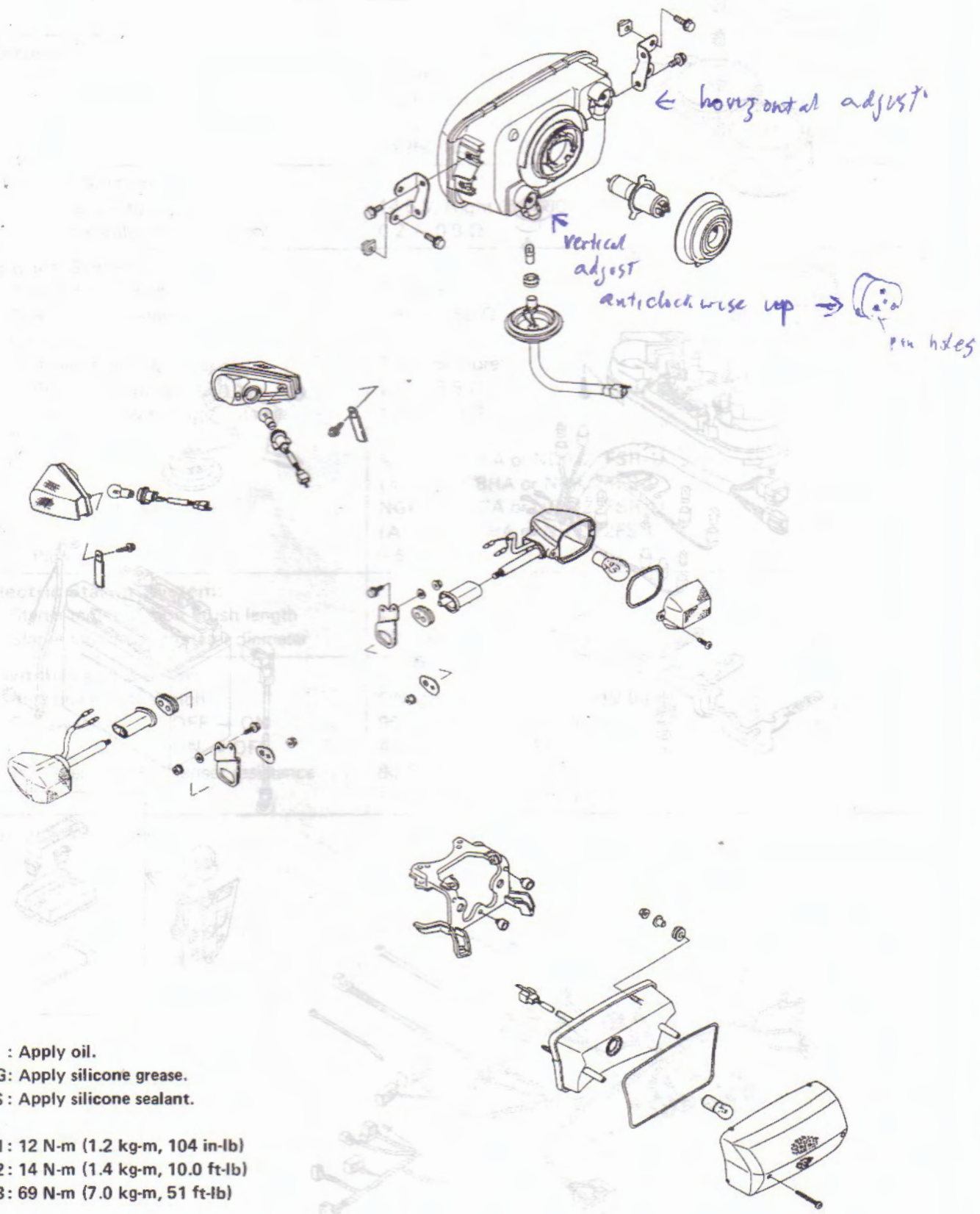

O : Apply oil.
 SG: Apply silicone grease.
 SS: Apply silicone sealant.

T1: 12 N-m (1.2 kg-m, 104 in-lb)
 T2: 14 N-m (1.4 kg-m, 10.0 ft-lb)
 T3: 69 N-m (7.0 kg-m, 51 ft-lb)

15-4 ELECTRICAL SYSTEM

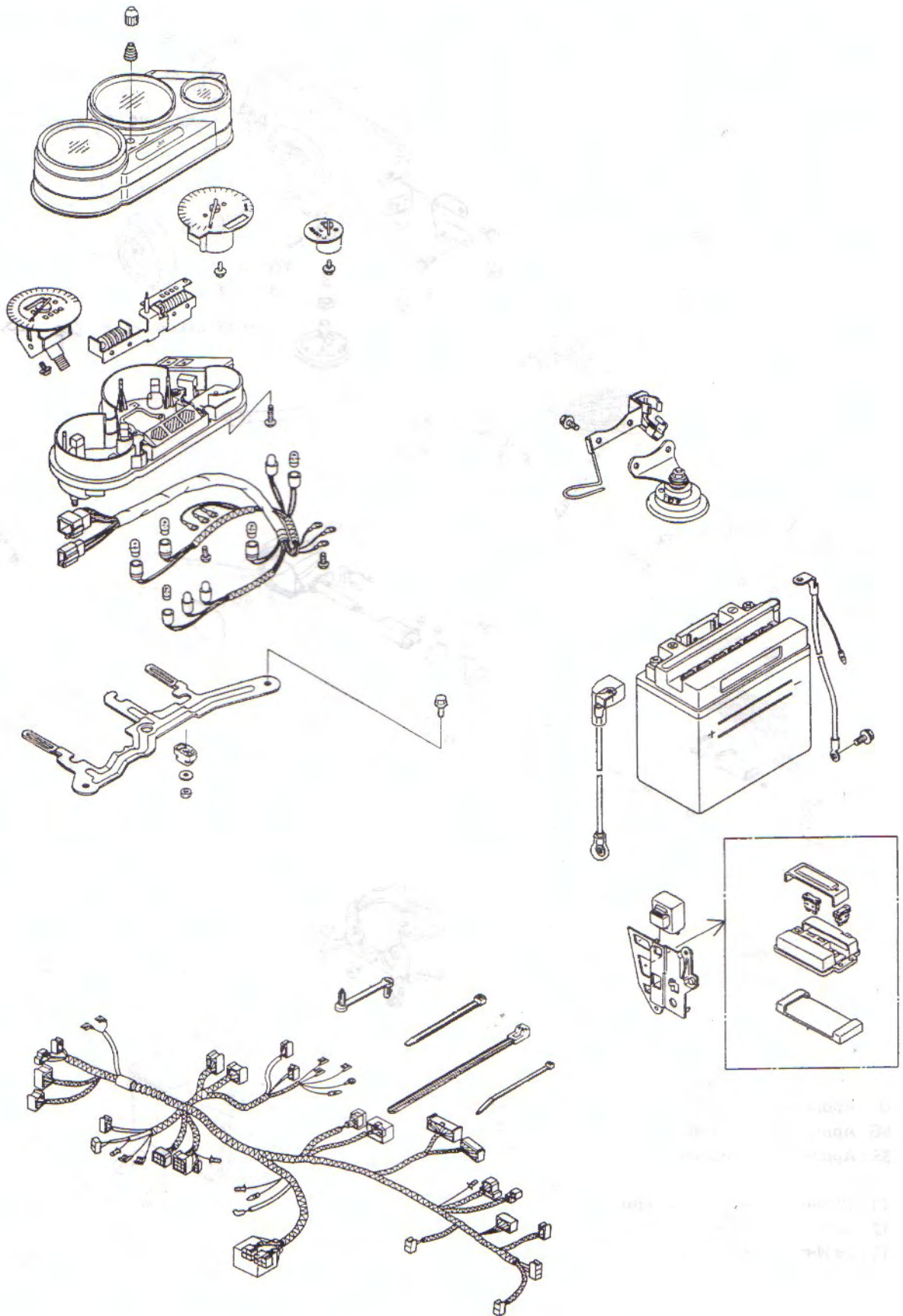

Specifications

Item	Standard	Service Limit
Battery:		
Type	EX250-H1 ~ H4: 12 V 8 Ah EX250-H5: 12 V 6 Ah	---
Specific gravity	EX250-H1 ~ H4: 1.280 EX250-H5: 1.320 @20°C (68°F)	---
Charging System:		
Charging voltage	14.5 V, Night @4 000 r/min (rpm)	---
Alternator stator coil resistance	0.2 ~ 0.9 Ω	---
Ignition System:		
Pickup coil air gap	0.7 mm	---
Pickup coil resistance	100 ~ 150 Ω	---
Ignition coil:		
3 needle arcing distance	7 mm or more	---
Primary winding resistance	2.2 ~ 3.5 Ω	---
Secondary winding resistance	10 ~ 16 kΩ	---
Spark plug:		
Standard plug	NGK CR8HSA or ND U24FSR-U (A) NGK C8HA or ND U24FS-L	---
Optional plug	NGK CR7HSA or ND U22FSR-U (A) NGK C7HA or ND U22FS-L	---
Plug gap	0.6 ~ 0.7 mm	---
Electric Starter System:		
Starter motor carbon brush length	11 mm	5 mm
Starter motor commutator diameter	23 mm	22 mm
Switches and Sensor:		
Rear brake light switch	ON after about 10 mm pedal travel	---
Fan switch: OFF → ON	96 ~ 100°C (205 ~ 212°F)	---
ON → OFF	Above 91°C (196°F)	---
Water temperature sensor resistance	80°C (176°F) : about 52 Ω 100°C (212°F) : about 27 Ω	---

(A) : Australia Model

15-6 ELECTRICAL SYSTEM

Special Tools

Hand Tester: 57001-983

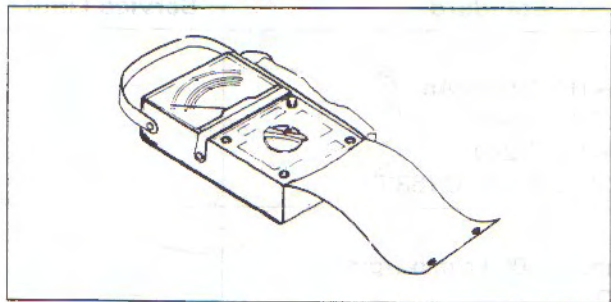

Flywheel Holder: 57001-1313

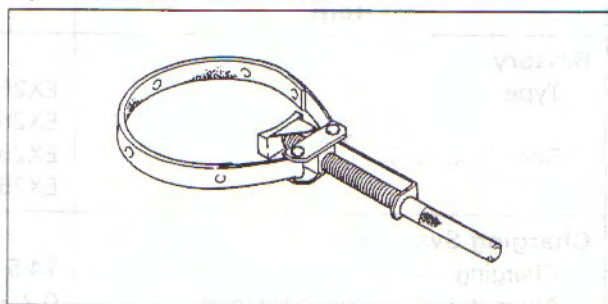

Rotor Puller, M16/M18/M20/M22 x 1.5: 57001-1216

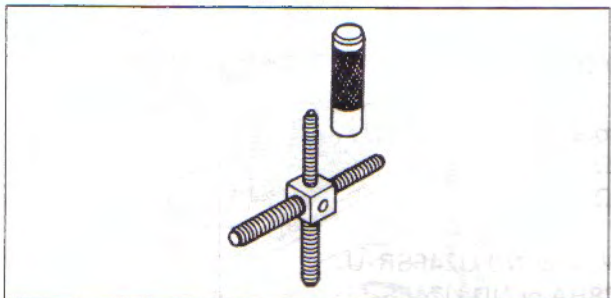

Sealant

Kawasaki Bond (Silicone Sealant): 56019-120

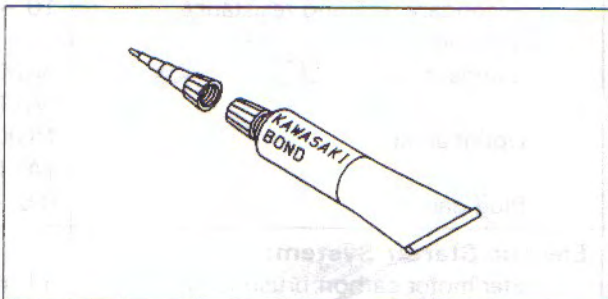

Flywheel Puller, M35 X 1.5: 57001-1223

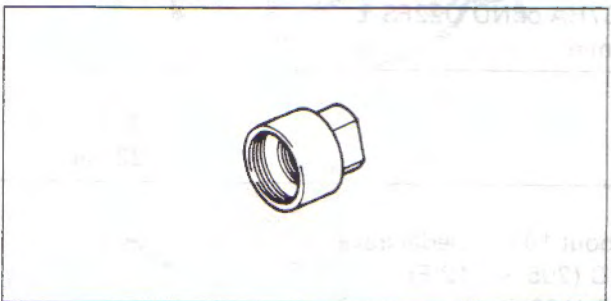

Coil Tester: 57001-1242

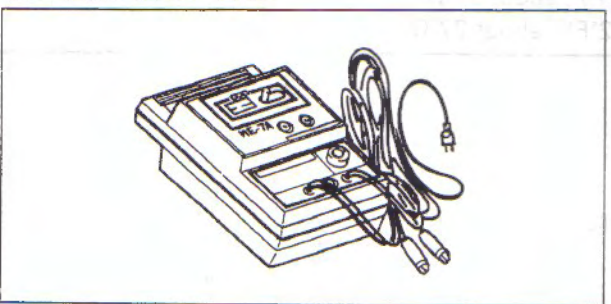

Spark Plug Wrench, Hex 16: 57001-1262

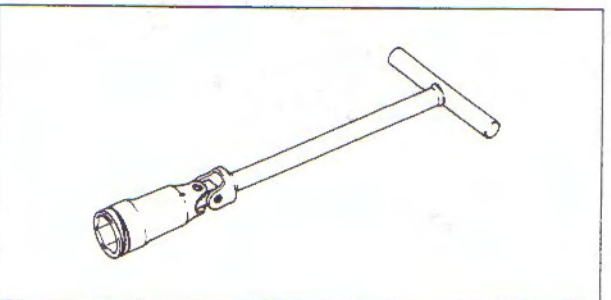

Parts Location

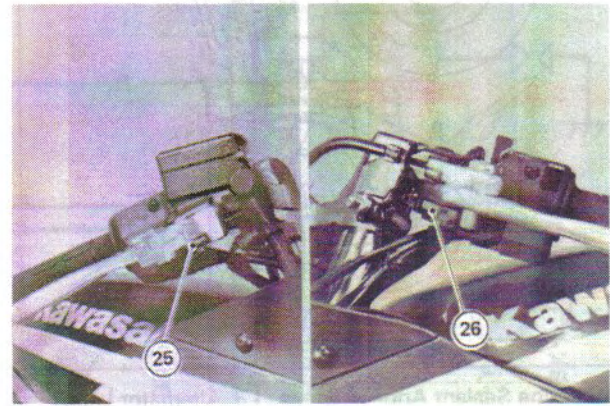
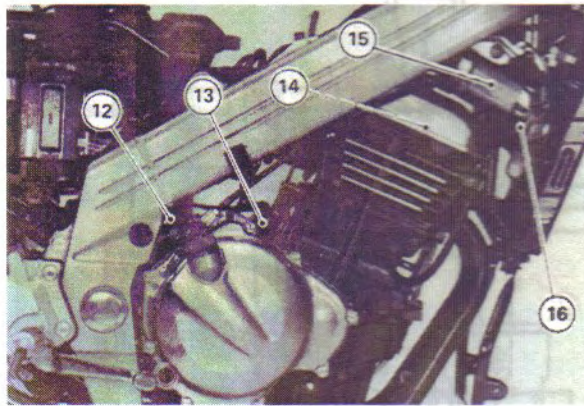
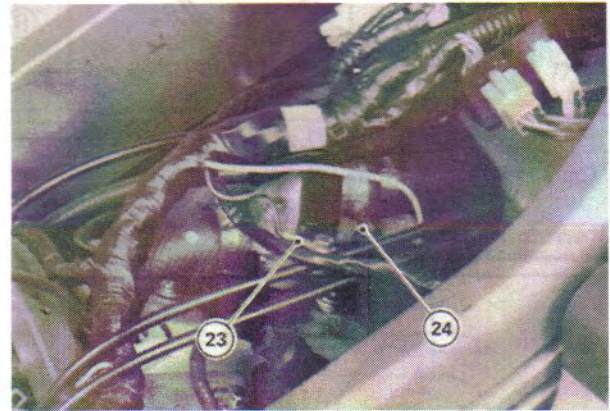
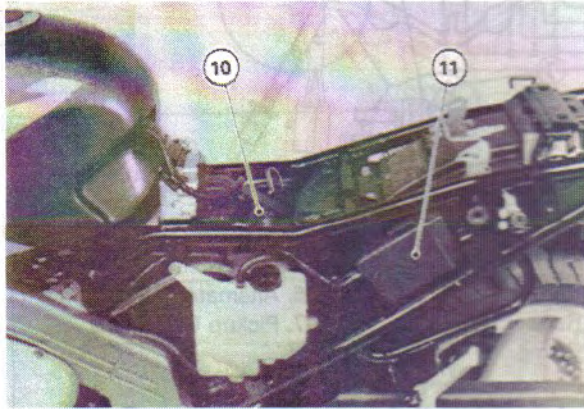
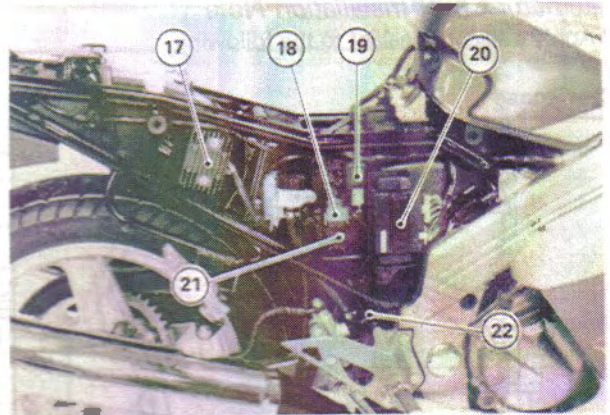
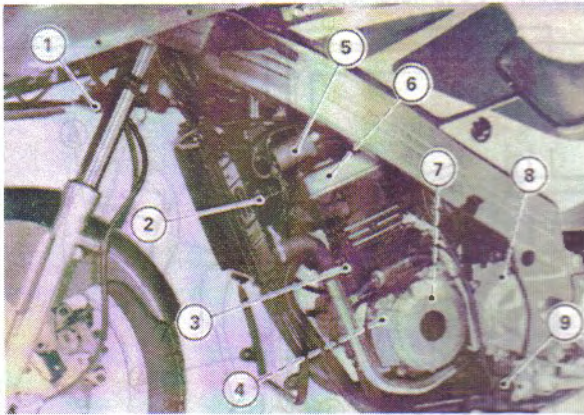

1. Horn
2. Radiator Fan Switch
3. Oil Pressure Switch
4. Pickup Coil
5. Ignition Coil (#1)
6. Spark Plug (#1)
7. Alternator
8. Neutral Switch
9. Side Stand Switch

10. Battery
11. IC Igniter
12. Ground Lead
13. Starter Motor
14. Spark Plug (#2)
15. Ignition Coil (#2)
16. Radiator Fan
17. Regulator/Rectifier
18. Main Fuse (30A)

19. Turn Signal Relay
20. Junction Box
21. Starter Relay
22. Rear Brake Light Switch
23. Ground Lead
24. Water Temperature Sensor
25. Front Brake Light Switch
26. Starter Lockout Switch

15-8 ELECTRICAL SYSTEM

Charging System

Alternator Cover Installation Note

- Apply a silicone sealant to the following.

Crankcase

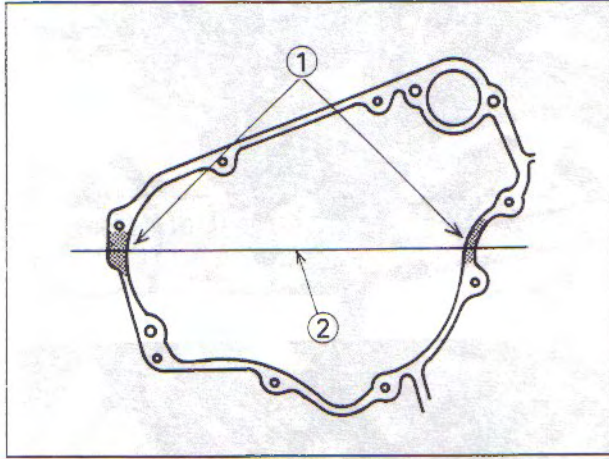

1. Silicone Sealant Applied Areas
2. Crankcase Mating Surface

Alternator Cover

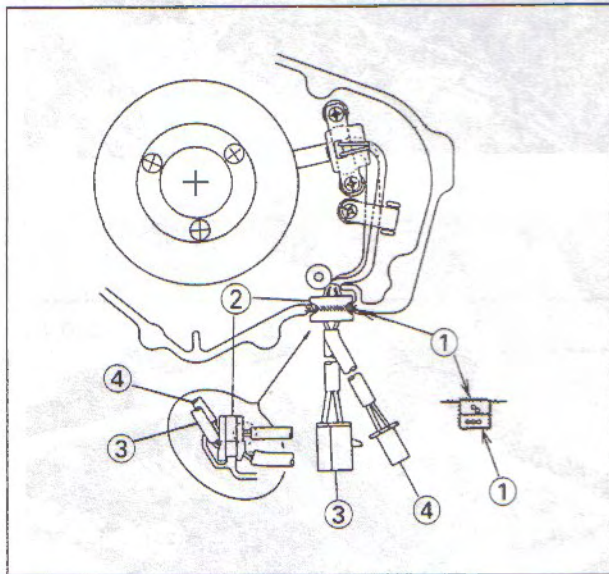

1. Silicone Sealant Applied Areas
2. Grommets
3. Alternator Leads
4. Pickup Coil Leads

Alternator Rotor Removal

Refer to the Base Manual, noting the following.

- Use the flywheel holder (special tool: 57001-1313) to keep the alternator rotor from turning.

Stator Coil Installation Notes

- Torque the following (see Exploded View).
Stator Coil Mounting Bolts
- Route the alternator leads as shown.

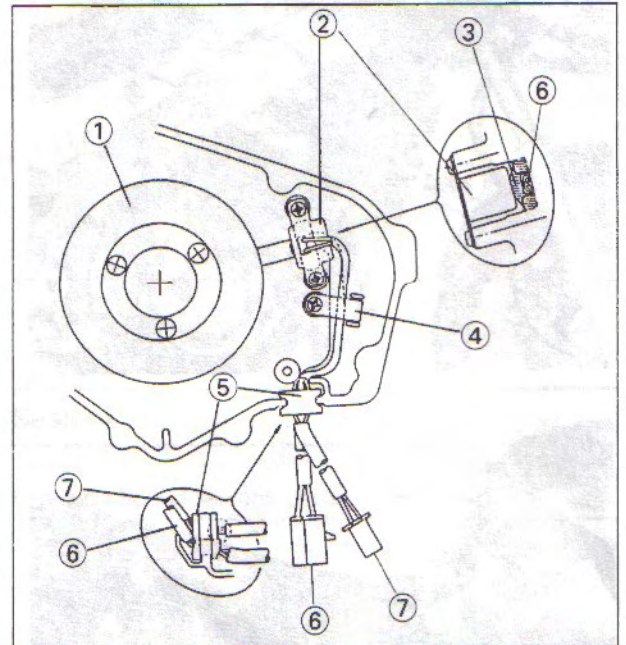

1. Stator Coil
2. Pickup Coil
3. Rubber Damper
4. Clamp
5. Grommets
6. Alternator Leads
7. Pickup Coil Leads

Charging System Circuit

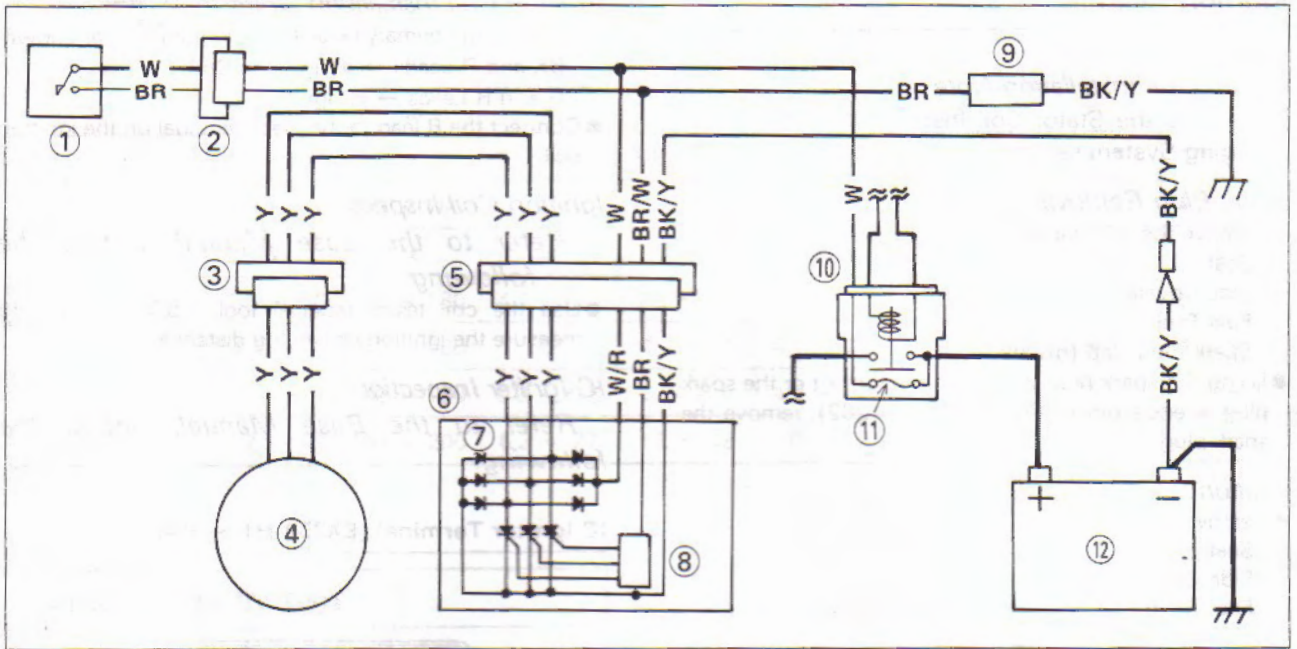

- | | | | |
|--------------------|------------------------|--------------|---------------------|
| 1. Ignition Switch | 4. Alternator | 7. Rectifier | 10. Starter Relay |
| 2. Connector 1 | 5. Connector 3 | 8. Regulator | 11. Main Fuse (30A) |
| 3. Connector 2 | 6. Regulator/Rectifier | 9. Loads | 12. Battery |

Ignition System Circuit

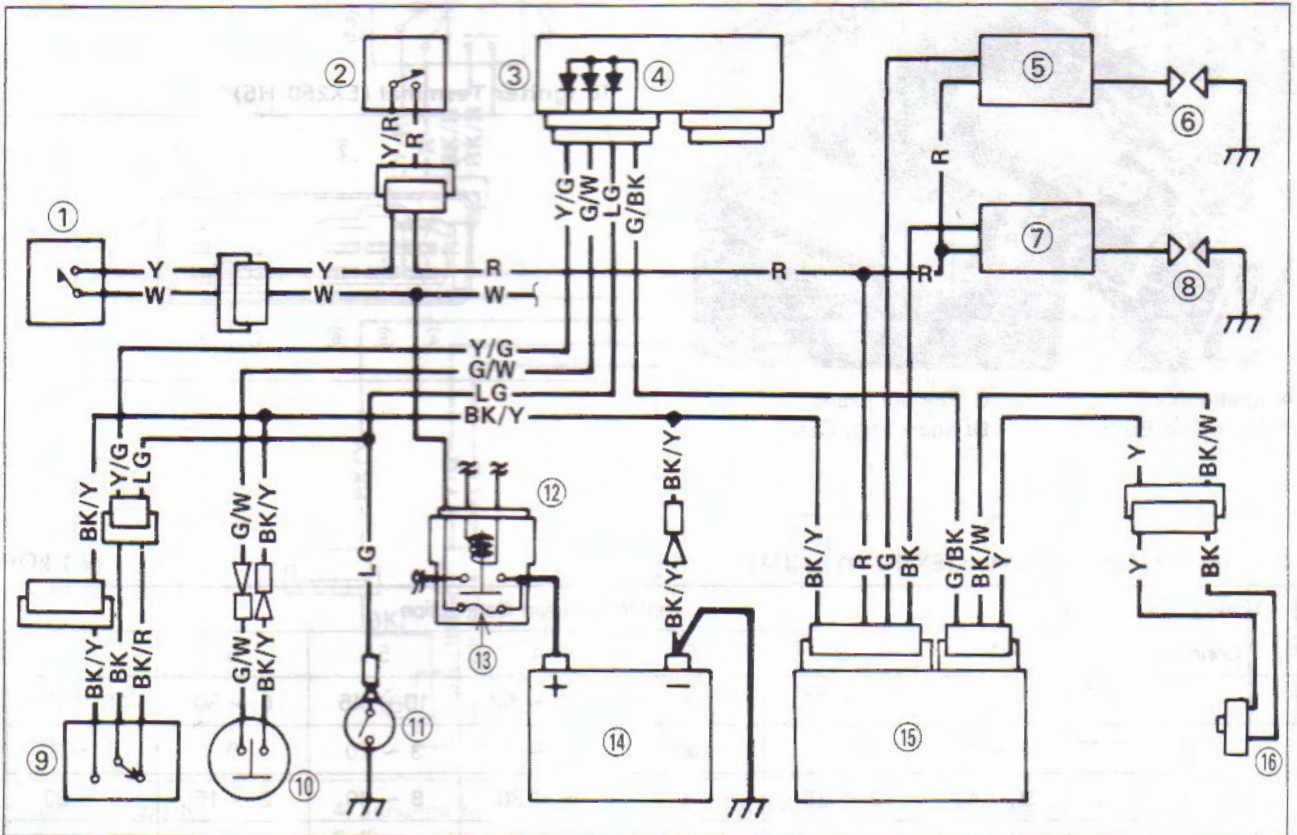

- | | | | |
|-----------------------|-----------------------|---------------------------|---------------------|
| 1. Ignition Switch | 5. Ignition Coil (#2) | 9. Starter Lockout Switch | 13. Main Fuse (30A) |
| 2. Engine Stop Switch | 6. Spark Plug (#2) | 10. Side Stand Switch | 14. Battery |
| 3. Junction Box | 7. Ignition Coil (#1) | 11. Neutral Switch | 15. IC Igniter |
| 4. Diodes | 8. Spark Plug (#1) | 12. Starter Relay | 16. Pickup Coil |

15-10 ELECTRICAL SYSTEM

Ignition System

Pickup Coil Installation Note

Refer to the Stator Coil Installation Notes in the Charging System section.

Spark Plug Removal

- Remove the following.
 - Seat
 - Side Covers
 - Fuel Tank
 - Spark Plug Cap (disconnect)
- Using the spark plug wrench in the tool kit or the spark plug wrench (special tool: 57001-1262), remove the spark plug.

Ignition Coil Removal

- Remove the following.
 - Seat
 - Side Covers
 - Fuel Tank
 - Lower Fairing
 - Spark Plug Cap (disconnect)
 - Ignition Coil Primary Leads (disconnect)
 - Ignition Coil Mounting Bolts

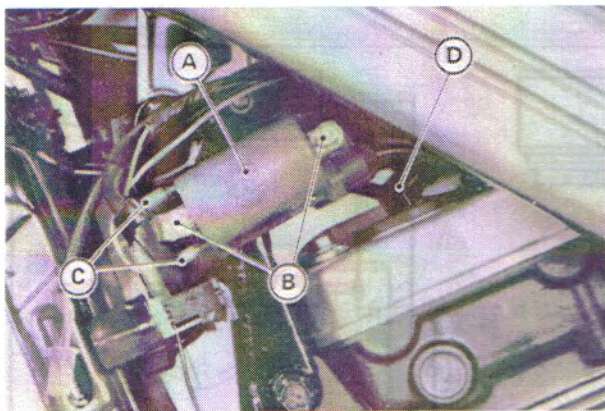

A. Ignition Coil
 B. Mounting Bolts
 C. Primary Leads
 D. Spark Plug Cap

Ignition Coil Installation Notes

- Connect the primary leads to the ignition coil as shown.
 - BK and R Leads → #1 Ignition Coil
 - G and R Leads → #2 Ignition Coil
- Connect the R lead to the black terminal on the ignition coil.

Ignition Coil Inspection

Refer to the Base Manual, noting the following.

- Use the coil tester (special tool: 57001-1242) to measure the ignition coil arcing distance.

IC Igniter Inspection

Refer to the Base Manual, noting the following.

IC Igniter Terminal (EX250-H1 ~ H4)

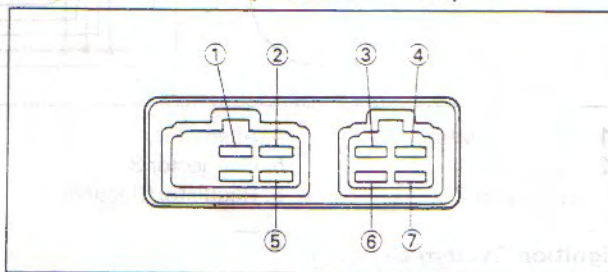

IC Igniter Terminal (EX250-H5)

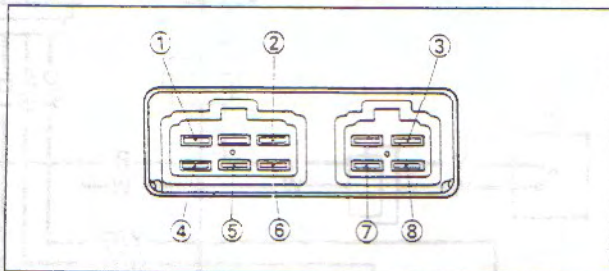

IC Igniter Internal Resistance (EX250-H1 ~ H4)

(x 1 kΩ)

Tester (-) Lead Connection	Tester (+) Lead Connection						
	1	2	3	4	5	6	7
1	-	6 ~ 30	∞	10 ~ 50	10 ~ 45	6 ~ 30	10 ~ 50
2	4 ~ 20	-	∞	1 ~ 8	3 ~ 20	0	1 ~ 8
3	9 ~ 40	2 ~ 15	-	6 ~ 30	8 ~ 40	2 ~ 15	6 ~ 30
4	∞	∞	∞	-	∞	∞	∞
5	8 ~ 35	4 ~ 20	∞	7 ~ 35	-	4 ~ 20	7 ~ 35
6	4 ~ 20	0	∞	1 ~ 8	3 ~ 20	-	1 ~ 8
7	∞	∞	∞	∞	∞	∞	-

IC Igniter Internal Resistance (EX250-H5/H7)

Tester (-) Lead Connection	Tester (+) Lead Connection							
	1	2	3	4	5	6	7	8
1	-	∞	∞	∞	∞	∞	∞	∞
2	6.6 ~ 27	-	2.8 ~ 12	6.6 ~ 27	9 ~ 36	2.8 ~ 12	3.1 ~ 13	10 ~ 40
3	1.7 ~ 7	40 ~ 160	-	1.7 ~ 7	4.1 ~ 16	0	0.2 ~ 0.8	4.2 ~ 17
4	∞	∞	∞	-	∞	∞	∞	∞
5	7.5 ~ 30	45 ~ 180	4.2 ~ 17	7.5 ~ 30	-	4.2 ~ 17	4.5 ~ 18	8.5 ~ 34
6	1.7 ~ 7	40 ~ 160	0	1.7 ~ 7	4.1 ~ 16	-	0.2 ~ 0.8	4.2 ~ 17
7	2 ~ 8.1	40 ~ 160	0.2 ~ 0.8	2 ~ 8.1	4.2 ~ 17	0.2 ~ 0.8	-	4.2 ~ 17
8	12 ~ 48	50 ~ 200	6.3 ~ 27	12 ~ 48	10 ~ 42	6.3 ~ 27	7 ~ 28	-

Electric Starter System

Refer to the Base Manual, noting the following.

Electric Starter Circuit

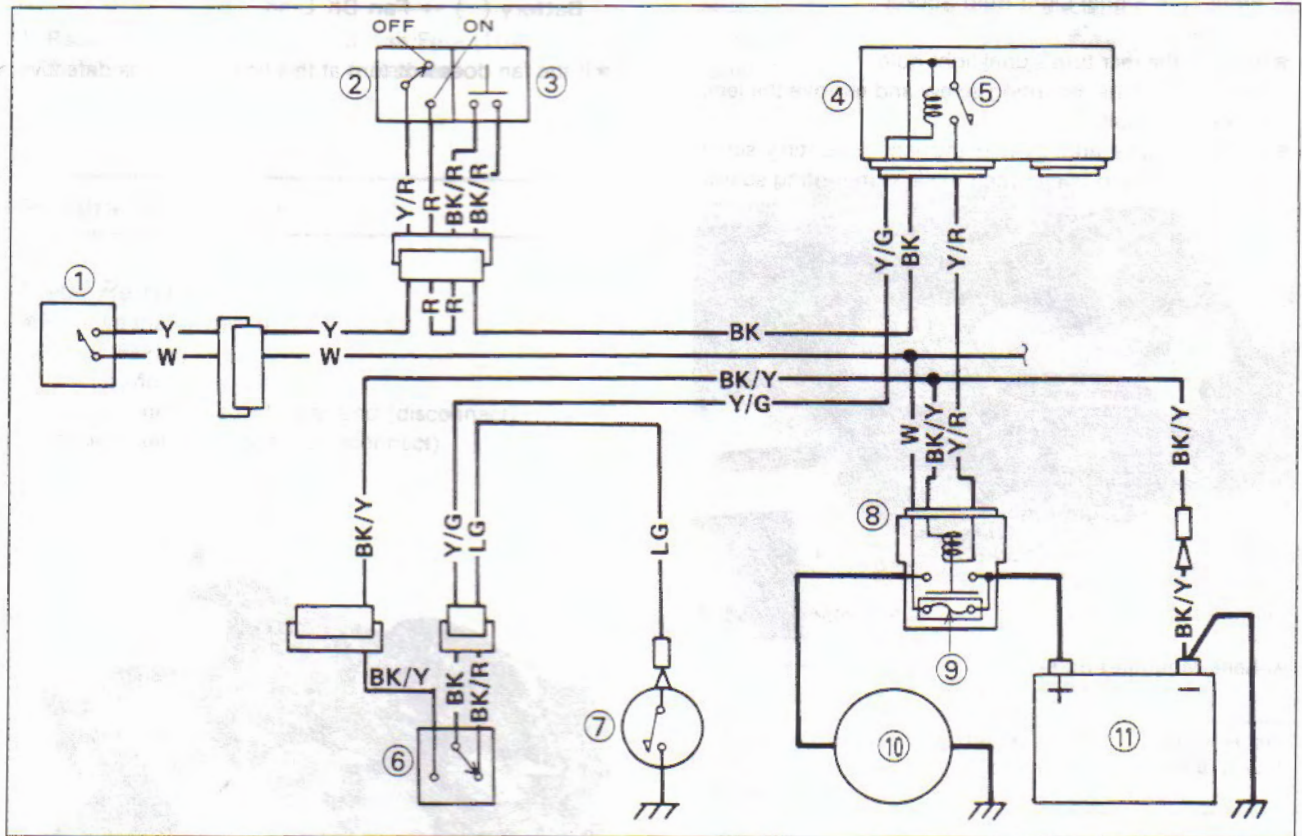

- | | | | |
|-----------------------|---------------------------|--------------------|-------------------|
| 1. Ignition Switch | 4. Junction Box | 7. Neutral Switch | 10. Starter Motor |
| 2. Engine Stop Switch | 5. Starter Circuit Relay | 8. Starter Relay | 11. Battery |
| 3. Starter Button | 6. Starter Lockout Switch | 9. Main Fuse (30A) | |

Lighting System

Turn Signal Light Bulb Replacement

- Remove the front turn signal light bulb.
- Turn the socket counterclockwise and remove the bulb and socket.
- Replace the bulb.
- Insert the socket by aligning the projection with the notch and turn the socket clockwise.

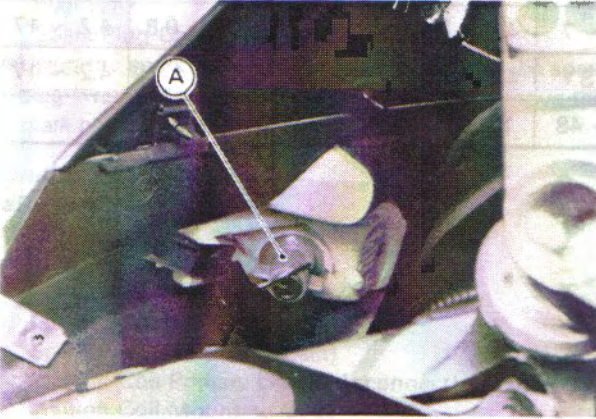

A. Front Turn Signal Light Bulb Socket

- Remove the rear turn signal light bulb.
- Remove the lens mounting screw and remove the lens.
- Replace the bulb.
- Install the lens and tighten the lens mounting screw. Be careful not to overtighten the lens mounting screw.

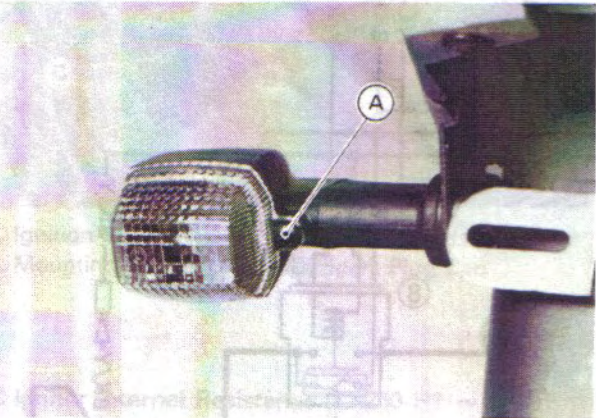

A. Lens Mounting Screw

Radiator Fan System

Fan System Circuit Inspection

- Remove the following.
 - Left Lower Fairing
 - Fan Switch Lead Connector (disconnect)
- Using an auxiliary wire, connect the fan switch leads.
- ★ If the fan turns, inspect the fan switch.
- ★ If the fan does not turn, inspect the following.
 - Wires and Connectors
 - Main Fuse and Fan Fuse
 - Radiator Fan

Fan Inspection

- Remove the following.
 - Right Lower Fairing
 - Fan Lead Connector (disconnect)
- Using the auxiliary wires, supply battery power to the fan.

Wire Connections

- Battery (+) → Fan BL Lead
- Battery (-) → Fan BK Lead

- ★ If the fan does not turn at this time, the fan is defective.

Radiator Fan Circuit

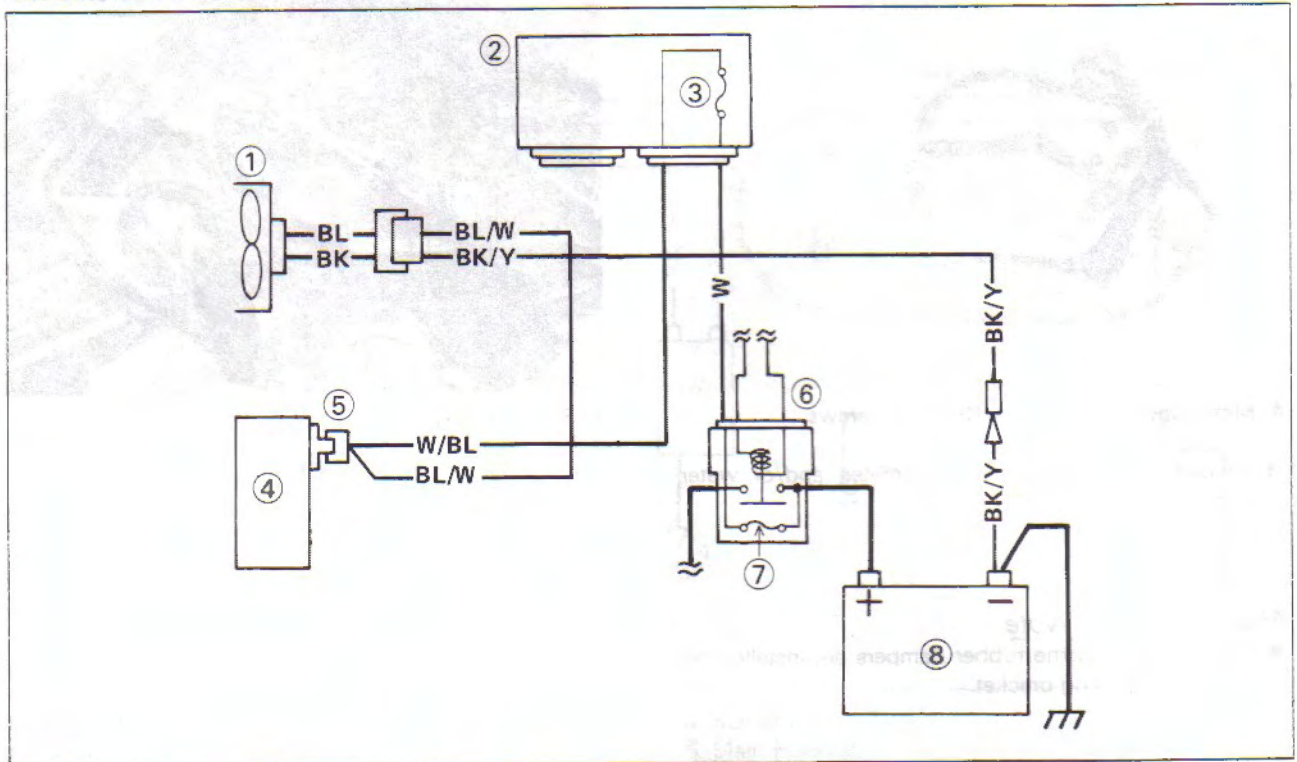

- 1. Radiator Fan
- 2. Junction Box
- 3. Fan Fuse (10A)
- 4. Radiator
- 5. Fan Switch
- 6. Starter Relay
- 7. Main Fuse (30A)
- 8. Battery

Meters and Gauge

Meter Removal

- Remove the following.
 - Inner Fairing
 - Meter Mounting Bolts
 - Speedometer Cable Upper End (disconnect)
 - Meter Lead Connectors (disconnect)

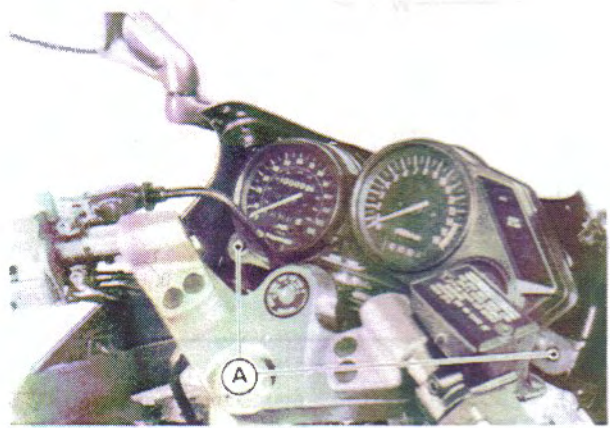

A. Meter Mounting Bolts

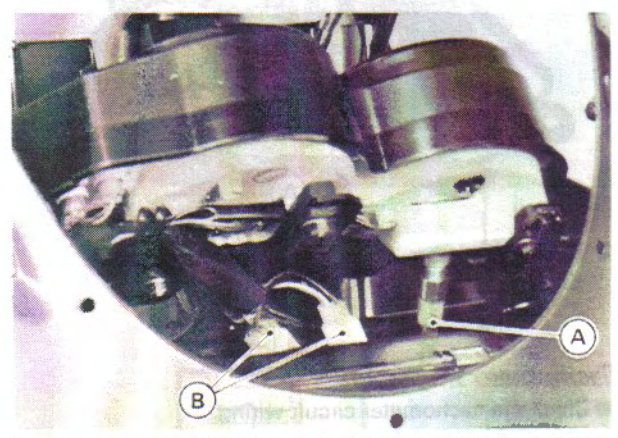

A. Speedometer Cable B. Meter Lead Connectors

CAUTION

Place the meter so that the face is up. If a meter is left upside down or sideways for any length of time, it will malfunction.

- Meter Bracket
- Reset Knob
- Meter Cover

15-14 ELECTRICAL SYSTEM

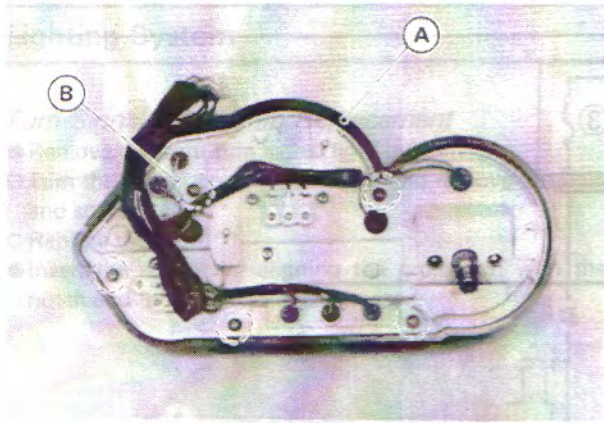

A. Meter Cover

B. Cover Screws

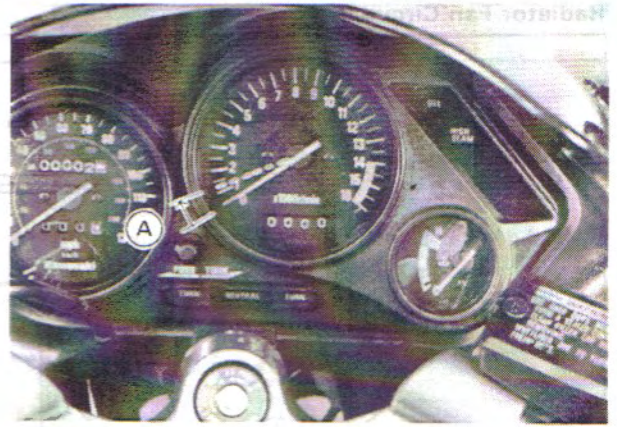

A. Pointer flicks.

- Remove the speedometer, tachometer, and/or water temperature gauge.

Meter Installation Note

- Check to see that the rubber dampers are installed on the meter mounting bracket.

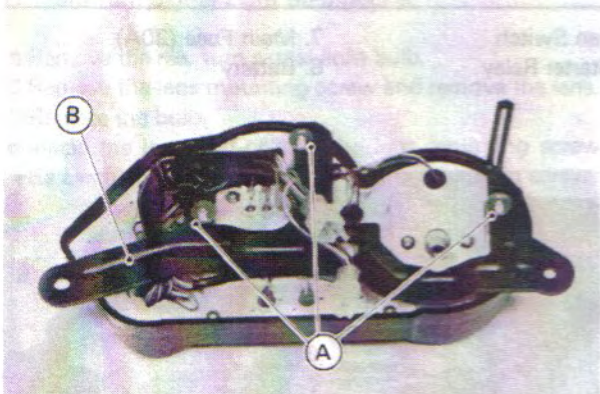

A. Rubber Dampers

B. Mounting Bracket

Tachometer Inspection

- Check the tachometer circuit wiring.
- ★ If all wiring and components other than the tachometer unit check out good, the unit is suspect. Check the unit as shown.
- Remove the following.
 - Seat
 - Left Lower Fairing
- Disconnect the BK lead from the #1 ignition coil.
- Turn the ignition switch ON.
- Open or connect the BK lead to the battery positive terminal using an auxiliary lead. Then the pointer should flick.
- Turn the ignition switch OFF.
- ★ If the pointer does not flick, replace the tachometer unit.

Tachometer Circuit

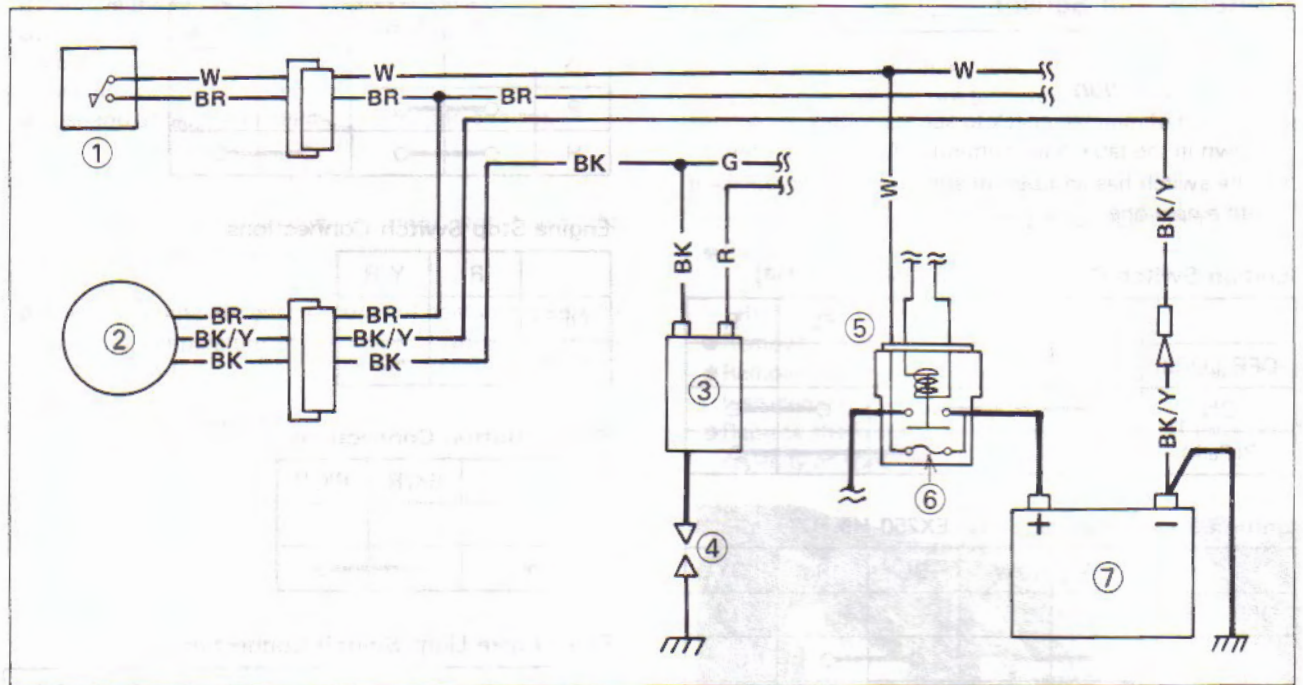

- 1. Ignition Switch
- 2. Tachometer
- 3. Ignition Coil (#1)
- 4. Spark Plug (#1)

- 4. Starter Relay
- 5. Main Fuse (30A)
- 7. Battery

Water Temperature Gauge Circuit

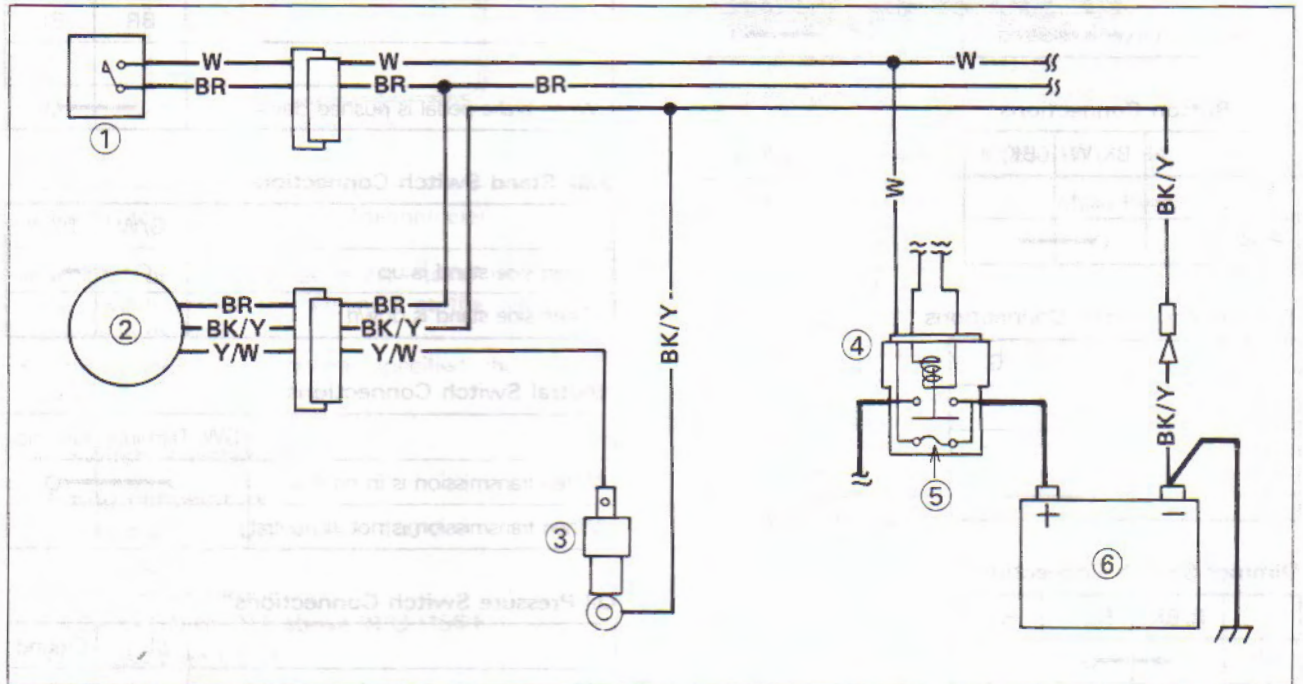

- 1. Ignition Switch
- 2. Water Temperature Gauge
- 3. Water Temperature Sensor

- 4. Starter Relay
- 5. Main Fuse (30A)
- 6. Battery

15-16 ELECTRICAL SYSTEM

Switches and Sensor

Switch Inspection

- Using an ohmmeter, check to see that only connections shown in the table have continuity (about zero ohms).
- ★ If the switch has an open or short, repair it or replace it with a new one.

Ignition Switch Connections (EX250-H1 ~ H4)

	BR	W	Y	BL	R
OFF, LOCK					
ON	○	○	○	○	○
P(Park)			○	○	○

Ignition Switch Connections (EX250-H5/H7)

	BR	W	BL	R	GY
OFF, LOCK					
ON	○	○	○	○	○
P(Park)		○	○	○	

Starter Lockout Switch Connections

	BK/Y	BK	BK/R
When clutch lever is pulled in	○	○	
When clutch lever is released		○	○

Horn Button Connections

	BK/W	BK/Y
Push on	○	○

Turn Signal Switch Connections

	GY	O	G
R	○	○	
N			
L		○	○

Dimmer Switch Connections

	R/BK	BL/Y	R/Y
HI	○	○	
LO		○	○

Passing Button Connections

	BR	R/BK
Push on	○	○

Headlight Switch Connections

	R/W	R/BL	BL	BL/Y
○				
P	○	○		
H	○	○	○	○

Engine Stop Switch Connections

	R	Y/R
OFF		
RUN	○	○

Starter Button Connections

	BK/R	BK/R
Push on	○	○

Front Brake Light Switch Connections

	BK	BK
When brake lever is pulled in	○	○

Rear Brake Light Switch Connections

	BR	BL
When brake pedal is pushed down	○	○

Side Stand Switch Connections

	G/W	BK/Y
When side stand is up	○	○
When side stand is down		

Neutral Switch Connections

	SW. Terminal	Ground
When transmission is in neutral	○	○
When transmission is not in neutral		

Oil Pressure Switch Connections*

	BL/R	Ground
When engine is stopped	○	○
When engine is running		

*Engine lubrication system is in good condition.

Fan Switch Inspection

- Remove the fan switch.
- Suspend the switch in a container of coolant so that the temperature-sensing projection and threaded portion are submerged.
- Suspend an accurate thermometer in the coolant.

NOTE

- The switch and thermometer must not touch the container sides or bottom.
- Place the container over a source of heat and gradually raise the temperature of the coolant while stirring the coolant gently.

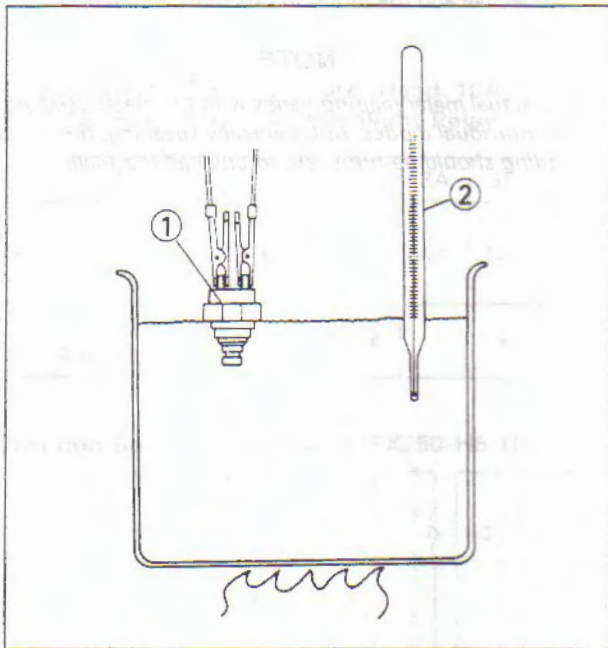

1. Fan Switch

2. Thermometer

- Using an ohmmeter, measure the internal resistance of the switch across the terminals at the temperature shown in the table.
- ★ If the meter does not read as specified, the switch is defective.

Fan Switch Resistance**Rising temperature:**

From OFF to ON at 96 ~ 100°C
(205 ~ 212°F)

Falling temperature:

From ON to OFF above 91°C (196°F)

ON: Less than 0.5 Ω

OFF: More than 1 MΩ

Junction Box

The junction box has fuses, relays, and diodes. The relays and diodes can not be removed.

Fuse Circuit Inspection and Replacement

- Remove:
 - Seat
 - Right Side Cover
- Remove the junction box.
- Remove the fuse from the junction box and inspect the fuse element.
- Replace the blown fuse with a new one of the correct capacity as specified on the junction box.

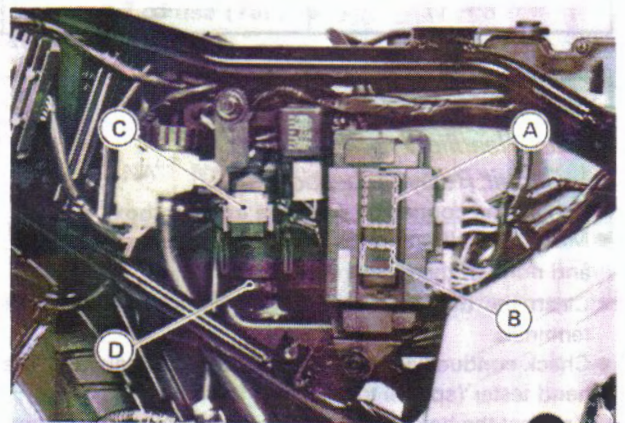

A. Fuses (10A)

C. Main Fuse (30A)

B. Spare Fuse (10A, 30A)

D. Spare Fuse (30A)

Fuse Circuit Inspection (EX250-H1 ~ H4)

Meter Connection	Meter Reading (Ω)
*1 - 3B	0
1 - 2	0
6 - 7	0
6 - 17	0
1 - 7	∞
8 - 17	∞

(*) : EX250-H3, H4 Australian Model only

15-18 ELECTRICAL SYSTEM

Fuse Circuit Inspection (EX250-H5/H7)

Meter Connection	Meter Reading (Ω)
1 - 3B	0
1 - 2	0
3A - 4	0
5 - 6	0
7 - 6	0
10 - 6	0
17 - 6	0
1 - 4	∞
1 - 5	∞
3A - 10	∞
8 - 17	∞

Starter/Headlight

Circuit Relay Inspection

- Pull off the connectors from the junction box.
- Make sure all connector terminals are clean and tight, and none of them have been bent.
- ★ Clean the dirty terminals, and straighten slightly-bent terminals.
- Check conductivity of the numbered terminals with the hand tester (special tool).
- Connect the hand tester and 12 V battery to the junction box as shown.
- ★ If the tester does not read as specified, replace the junction box.

Relay Circuit Inspection (with battery disconnected)

	Meter Connection	Meter Reading (Ω)
Starter Relay	11 - 13	∞
	11 - 12	other than ∞
* Headlight Relay	7 - 8	∞
	9 - 13	other than ∞

Relay Circuit Inspection (with battery connected)

	Meter Connection	Battery Connection (+) (-)	Meter Reading Ω
Starter Relay	11 - 13	11 - 12	0
* Headlight Relay	7 - 8	9 - 13	0

(*) : EX250-H3 ~ H5 Australian and EX250-H5 Malaysian Models only.

Diode Circuit Inspection

- Check conductivity of the following pair of terminals.

Terminals for Diode Circuit Inspection

(EX250-H1 ~ H4)

*13-8, *13-9, 12-14, 15-14, 16-14

(*) : EX250-H3, H4 Australian Model only

Terminals for Diode Circuit Inspection (EX250-H5)

*13-8, *13-9, 11-12, 12-14, 15-14, 16-14

(*) : Australian and Malaysian Models only

- ★ The resistance should be low in one direction and more than ten times as much in the other direction. If any diode shows low or high in both directions, the diode is defective and the junction box must be replaced.

NOTE

- The actual meter reading varies with the meter used and the individual diodes, but, generally speaking, the lower reading should be from zero to one half the scale.

Junction Box Internal Circuit (EX250-H1 ~ H4)

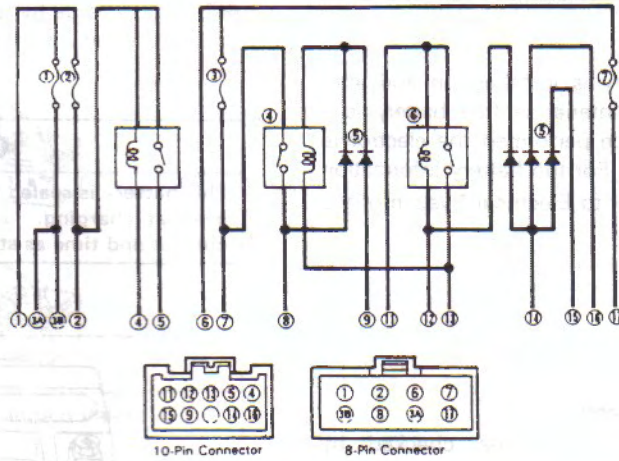

- 1. Fuse (Acc, 10A) 3. Fuse (Head, 10A) 5. Diodes 7. Fuse (Tail, 10A)
- 2. Fuse (Fan, 10A) 4. Headlight Relay 6. Starter Relay

Model	1	2	3A	3B	4	5	6	7	8	9	11	12	13	14	15	16	17
All Model (Other than EX250-H3, H4 Australian Model)	x	x	NA	NA	NA	NA	x	x	NA	NA	x	x	x	x	x	x	x
EX250-H3, H4 Australian Model	x	x	x	x	NA	NA	x	x	x	x	x	x	x	x	x	x	x

Junction Box Internal Circuit (EX250-H5/H7)

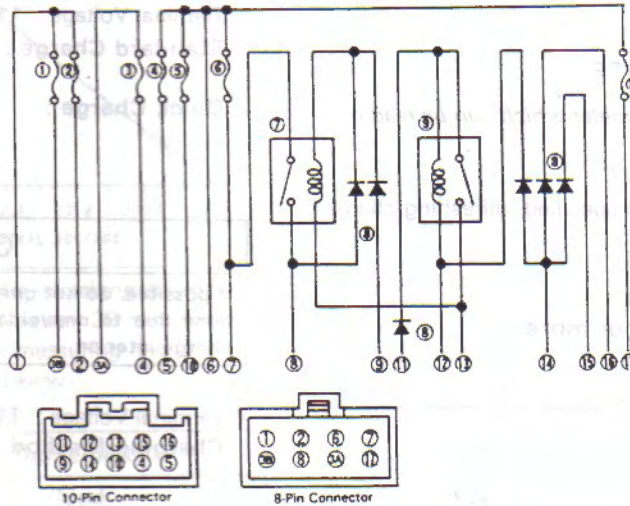

- 1. Fuse (Acc, 10A) 4. Fuse (Horn 10A) 7. Headlight Relay 10. Fuse (Tail 10A)
- 2. Fuse (Fan, 10A) 5. Fuse (Ignition 10A) Relay 8. Diodes
- 3. Fuse (Turn/S, 10A) 6. Fuse (Head 10A) 9. Starter Relay

	1	2	3A	3B	4	5	6	7	8	9	10	11	12	13	14	15	16	17
All Model (Other than Australian and Malaysian Models)	x	x	x	x	x	x	x	x	NA	NA	x	x	x	x	x	x	x	x
Australian and Malaysian Models	x	x	x	x	x	x	x	x	x	x	x	x	x	x	x	x	x	x

NOTE : x : Apply
NA : Not Apply

15-20 ELECTRICAL SYSTEM

Battery

Maintenance Free Battery

A maintenance free battery is installed on and after EX250-H5 model. The maintenance free battery is a sealed type, and so cannot be performed the electrolyte level check and topping-up. For the battery information of the EX250-H1 ~ H4, refer to Electrical System of the base Service Manual.

Charging Condition Inspection

Battery charging condition can be checked by measuring battery terminal voltage.

- Remove:
 - Seat
 - IC Igniter
 - Diode
- Disconnect the battery terminal leads.

CAUTION

Be sure to disconnect the negative terminal lead first.

- Measure the battery terminal voltage.

NOTE

○ Measure with a digital voltmeter which can be read one decimal place voltage.

★ If the reading is below the specified, refreshing charge is required.

Battery Terminal Voltage

Standard: 12.6 V or more

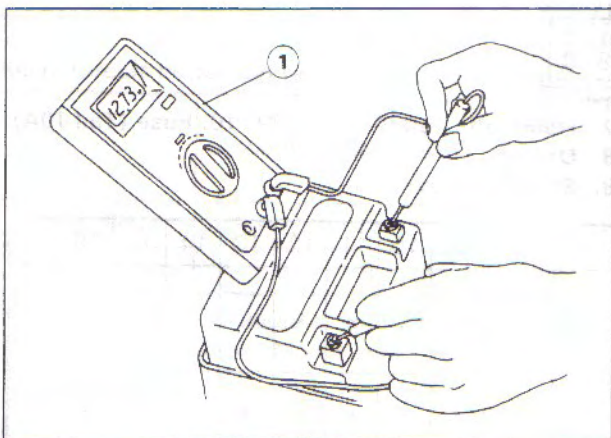

1. Digital Voltmeter

Refreshing Charge

- Remove the battery.
- Refresh—charge by following method according to the battery terminal voltage.

CAUTION

This battery is sealed type. Never remove sealing caps even at charging. Never add water. Charge with current and time as stated below.

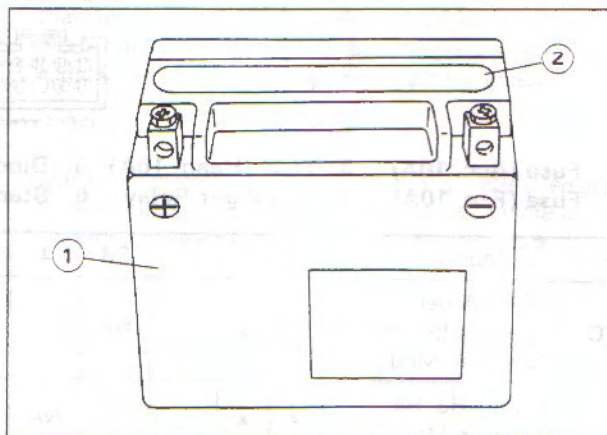

1. Battery

2. Sealing Cap

○ Terminal Voltage : 11.5 ~ 12.6 V or less

Standard Charge : 0.7 A × 5 ~ 10 h

(see following chart)

Quick Charge : 3.0 A × 1.0 h

CAUTION

If possible, do not quick charge. If the quick charge is done due to unavoidable circumstances, do standard charge later on.

○ Terminal Voltage : 11.5 V or less

Charging Method : 0.7 A × 20 h

NOTE

○ Raise the voltage initially (25 V as maximum), and charge for about 5 minutes as a yardstick. (If ammeter shows no change in current after 5 minutes, you need a new battery.) The current, if it can flow into the battery, tends to become excessive. Adjust the voltage as often as possible to keep the current at standard value (0.7 A).

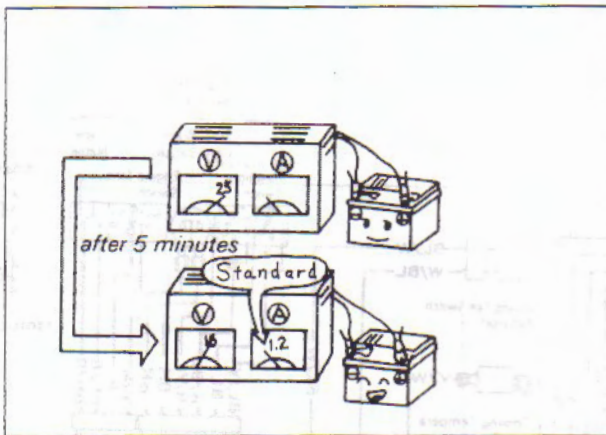

1. Battery Charger
2. Battery
3. Standard Value: 0.7 A

Battery Standard Charge Time Chart
 (0.7 A x 5 ~ 10 h Regular Current Charge)
 - For Reference

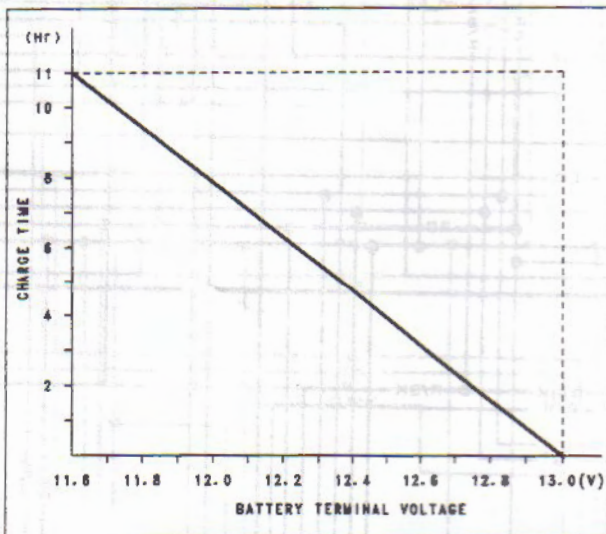

- Determine battery condition after refreshing charge.
- Determine the condition of the battery 30 minutes after completion of the charge by measuring the terminal voltage according to the table below.

Criteria	Judgement
12.6 V or higher	Good
12.0 ~ 12.6 V or lower	Charge insufficient → Recharge.
12.0 V or lower	Unserviceable → Replace.

EX250H1/H2/H3/H4 Wiring Diagram

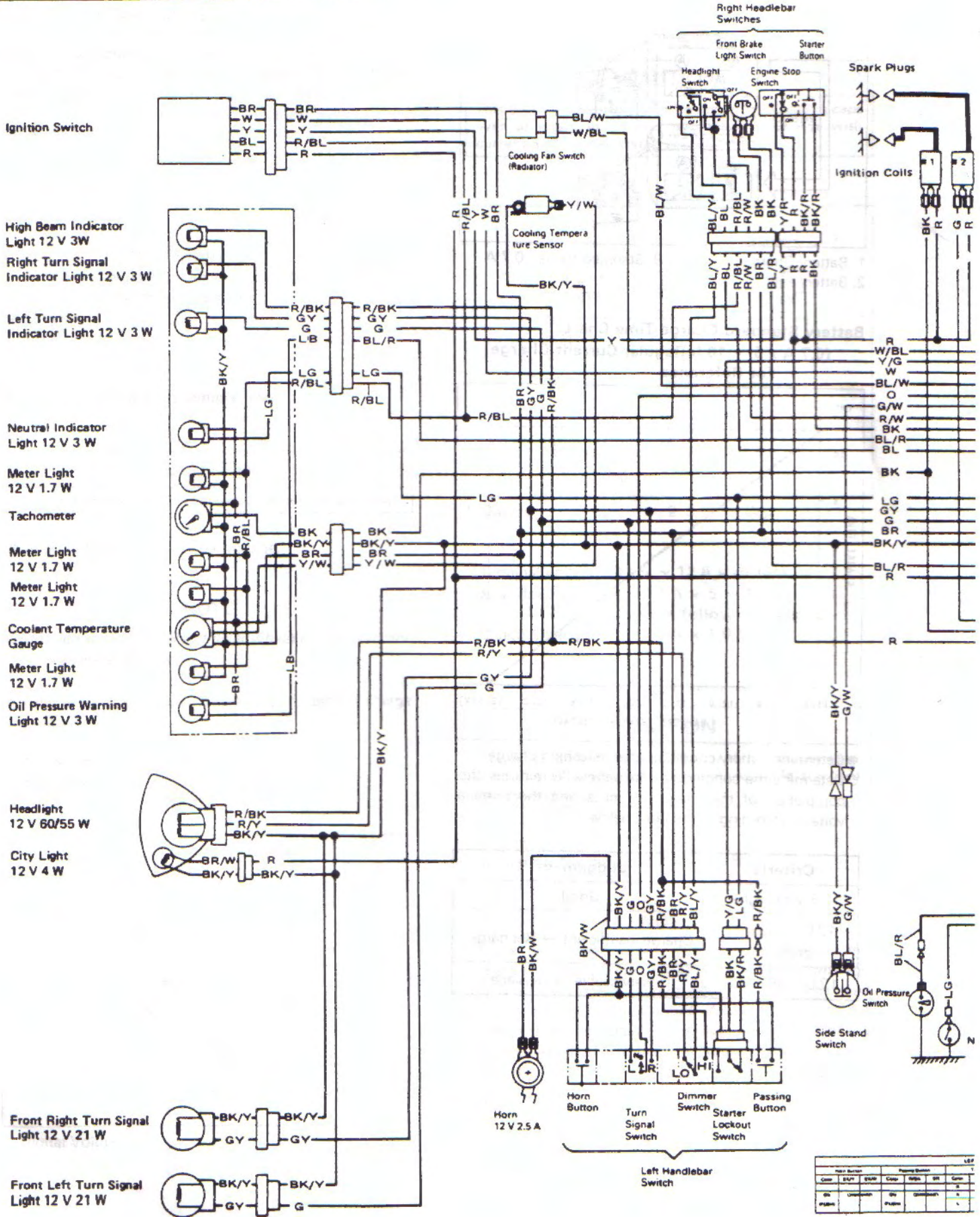

Part Number	Quantity	Notes
1	1	
2	1	
3	1	
4	1	
5	1	
6	1	
7	1	
8	1	
9	1	
10	1	
11	1	
12	1	
13	1	
14	1	
15	1	
16	1	
17	1	
18	1	
19	1	
20	1	
21	1	
22	1	
23	1	
24	1	
25	1	
26	1	
27	1	
28	1	
29	1	
30	1	
31	1	
32	1	
33	1	
34	1	
35	1	
36	1	
37	1	
38	1	
39	1	
40	1	
41	1	
42	1	
43	1	
44	1	
45	1	
46	1	
47	1	
48	1	
49	1	
50	1	
51	1	
52	1	
53	1	
54	1	
55	1	
56	1	
57	1	
58	1	
59	1	
60	1	
61	1	
62	1	
63	1	
64	1	
65	1	
66	1	
67	1	
68	1	
69	1	
70	1	
71	1	
72	1	
73	1	
74	1	
75	1	
76	1	
77	1	
78	1	
79	1	
80	1	
81	1	
82	1	
83	1	
84	1	
85	1	
86	1	
87	1	
88	1	
89	1	
90	1	
91	1	
92	1	
93	1	
94	1	
95	1	
96	1	
97	1	
98	1	
99	1	
100	1	

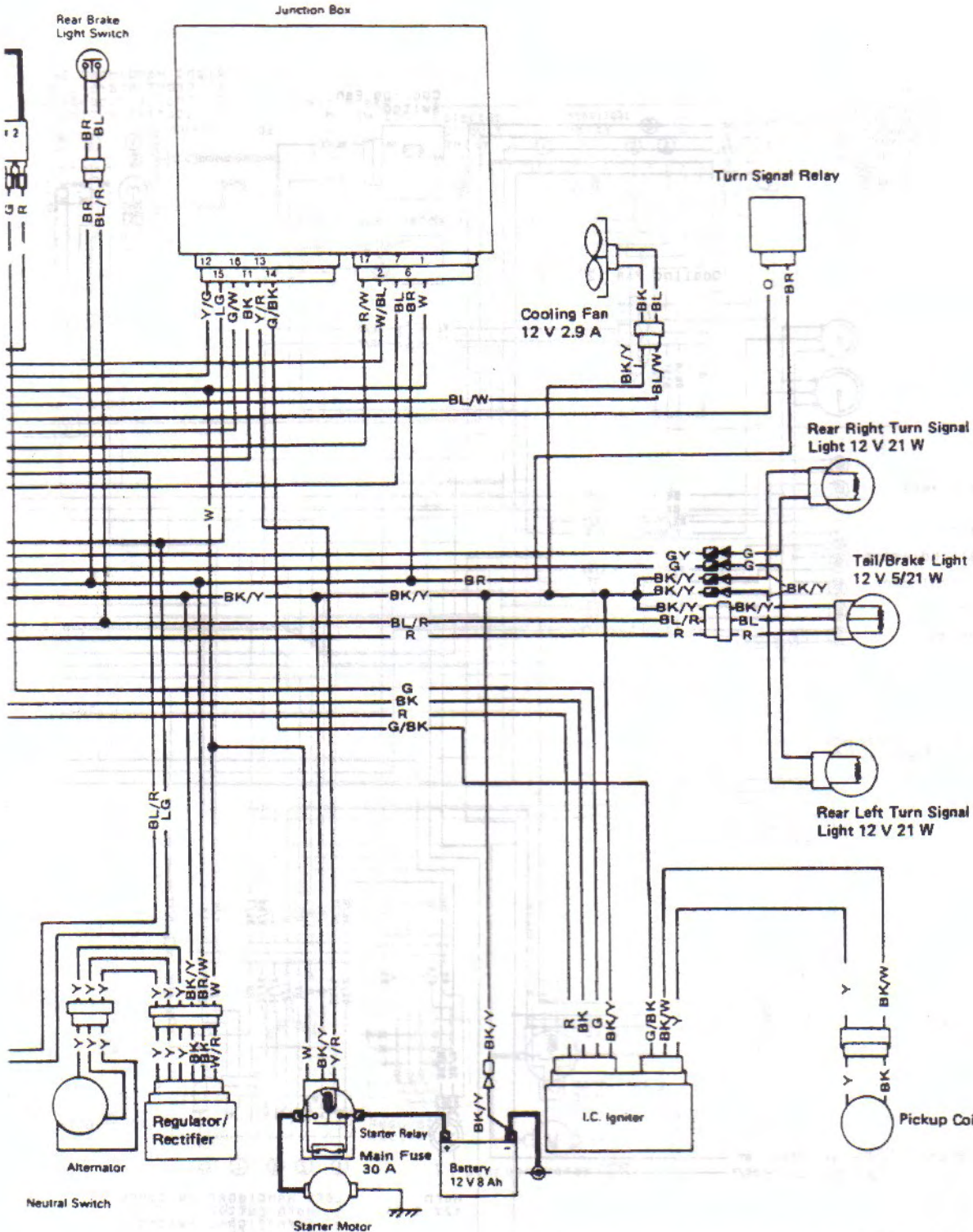

Color Code	
BK	Black
BL	Blue
BR	Brown
CH	Chocolate
DG	Dark Green
G	Green
GY	Gray
LB	Light Blue
LG	Light Green
O	Orange
P	Pink
PU	Purple
R	Red
W	White
Y	Yellow

LEFT HANDLEBAR SWITCH CONNECTIONS											
Turn Signal Switch			Brake Light Switch			Starter/Stop Switch					
Color	W	D	G	Color	W	BL	BL/Y	W/R	Color	BL/Y	W
---	---	---	---	---	---	---	---	---	---	---	---
---	---	---	---	---	---	---	---	---	---	---	---
---	---	---	---	---	---	---	---	---	---	---	---

IGNITION SWITCH CONNECTIONS					
Color	W	R	Y	W	W
---	---	---	---	---	---
---	---	---	---	---	---
---	---	---	---	---	---

RIGHT HANDLEBAR SWITCH CONNECTIONS											
Engine Stop Switch			Brake Light Switch			Starter/Stop Switch					
Color	W	R	Color	W	BL	W	W	W	W	W	W
---	---	---	---	---	---	---	---	---	---	---	---
---	---	---	---	---	---	---	---	---	---	---	---
---	---	---	---	---	---	---	---	---	---	---	---

15-24 ELECTRICAL SYSTEM

EX250-H5/H7 Wiring Diagram (Australia Model)

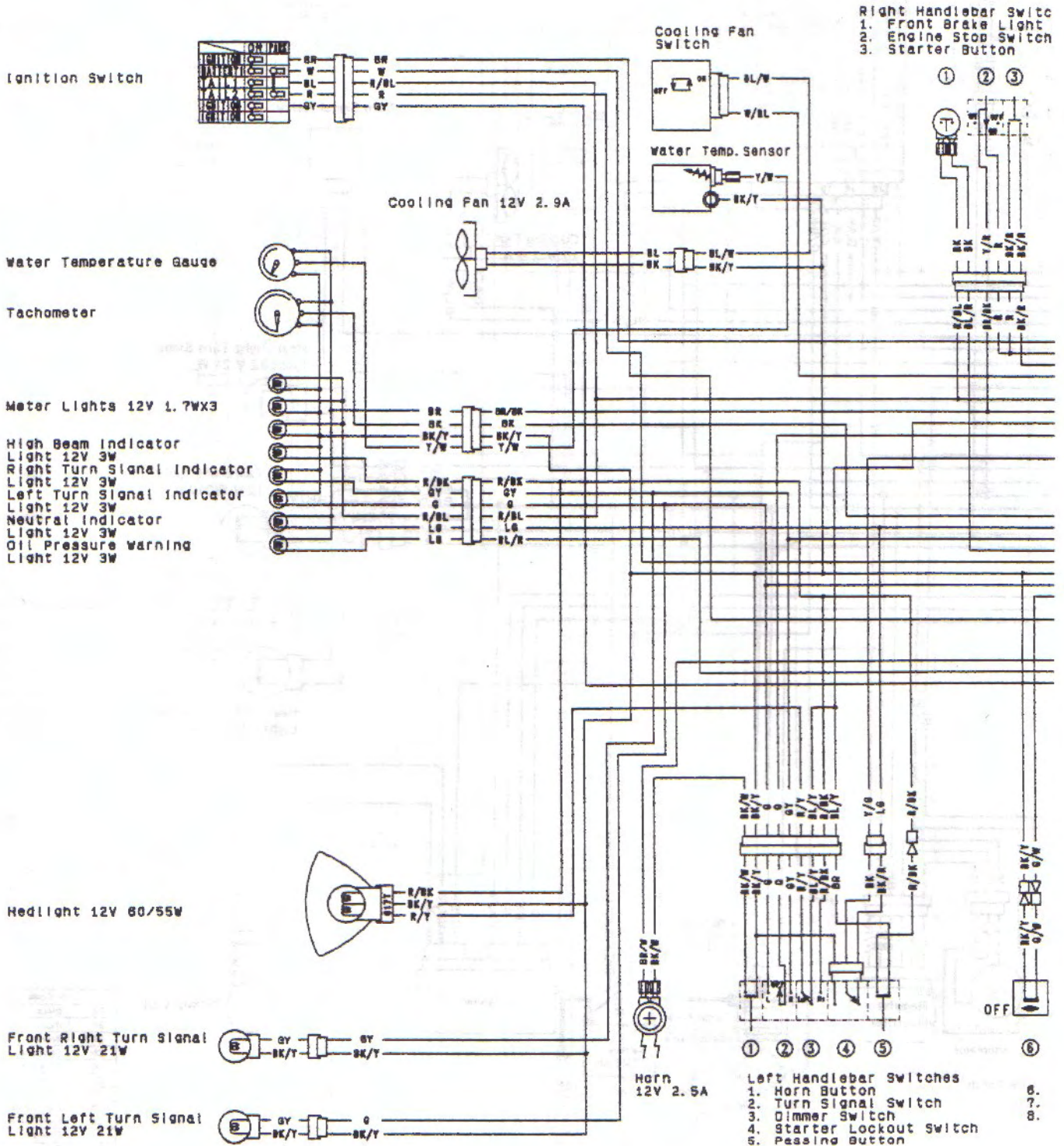

LEFT HANDLEBAR SWITCH CONNECTIONS									
Horn Button	Turn Signal Switch	Dimmer Switch	Starter Lockout Switch	Passing Bu					
Color BK/WBK/Y	Color G O GY	Color R/Y BL/YR/BK	Color BK/Y BK BK/W	Color BR					
Push	R	LO	Clutch Lever	Push					
Released	OFF(PULL)	HI	Released	Push					
	L		Pulled In						

Ignition Switches
 a Light Switch
 b Switch
 c tton

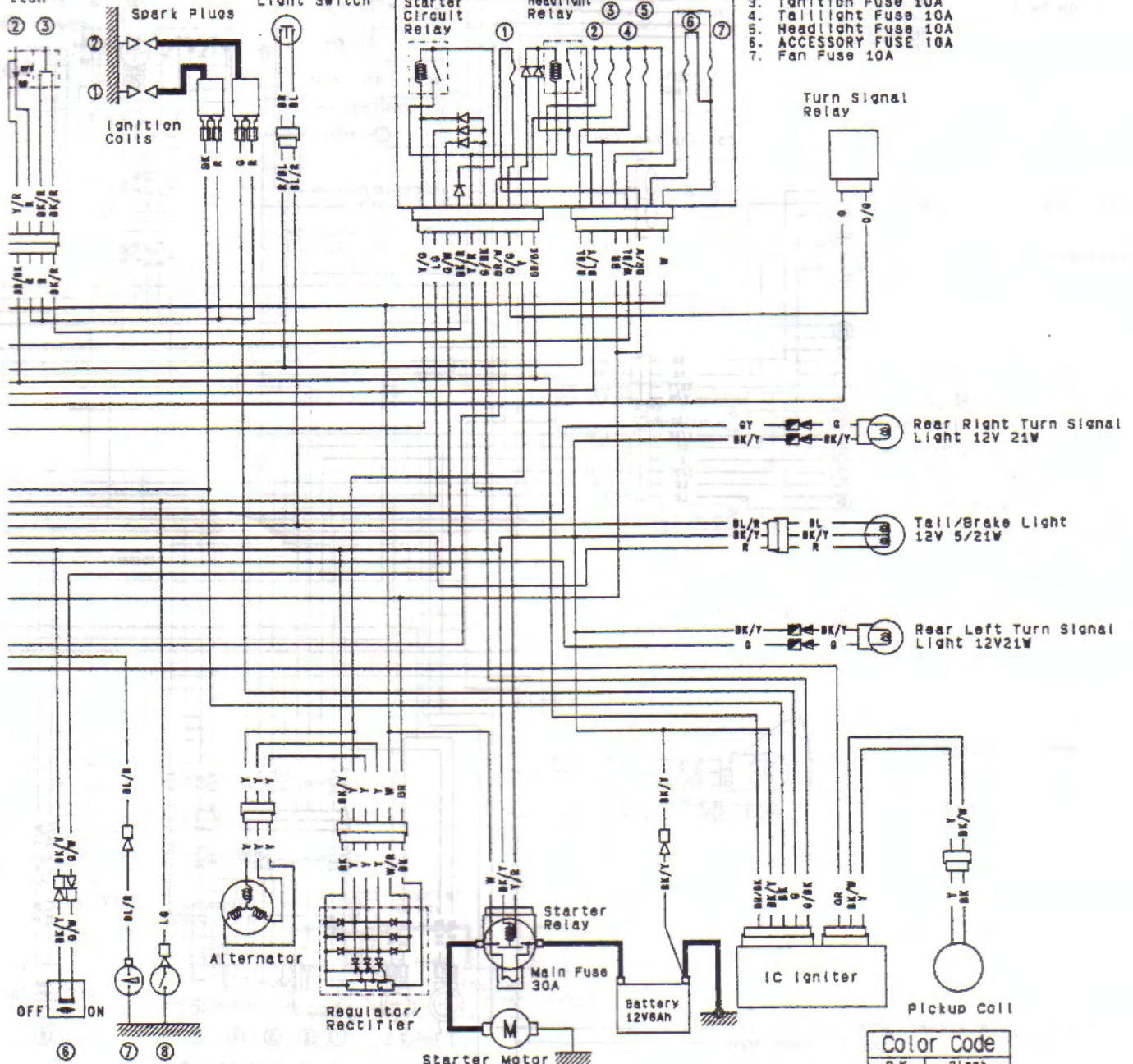

- Junction Box
1. Turn Signal Relay Fuse 10A
 2. Horn Fuse 10A
 3. Ignition Fuse 10A
 4. Taillight Fuse 10A
 5. Headlight Fuse 10A
 6. ACCESSORY FUSE 10A
 7. Fan Fuse 10A

6. side Stand switch
7. Oil Pressure Switch
8. Neutral Switch

Color Code	
BK	Black
BL	Blue
BR	Brown
CH	Chocolate
DG	Dark Green
G	Green
GY	Gray
LB	Light Blue
LG	Light Green
O	Orange
P	Pink
PU	Purple
R	Red
W	White
Y	Yellow

Passing Button	
Color	BR R/BK
Push	

IGNITION SWITCH CONNECTIONS					
	Ignition	Battery	Ignition	Tail 1	Tail 2
Color	BR	W	GY	BL	R
OFF, LOCK					
ON					
P(PARK)					

RIGHT HANDLEBAR SWITCH CONNECTIONS					
Front Brake Light Switch		Engine Stop Switch		Starter Button	
Color	BK BK	Color	Y/R R	Color	BK/W BK/R
Brake Lever		OFF		Push	
Pulled in		RUN		Push	

EX250-H5 Wiring Diagram (Europe Models)

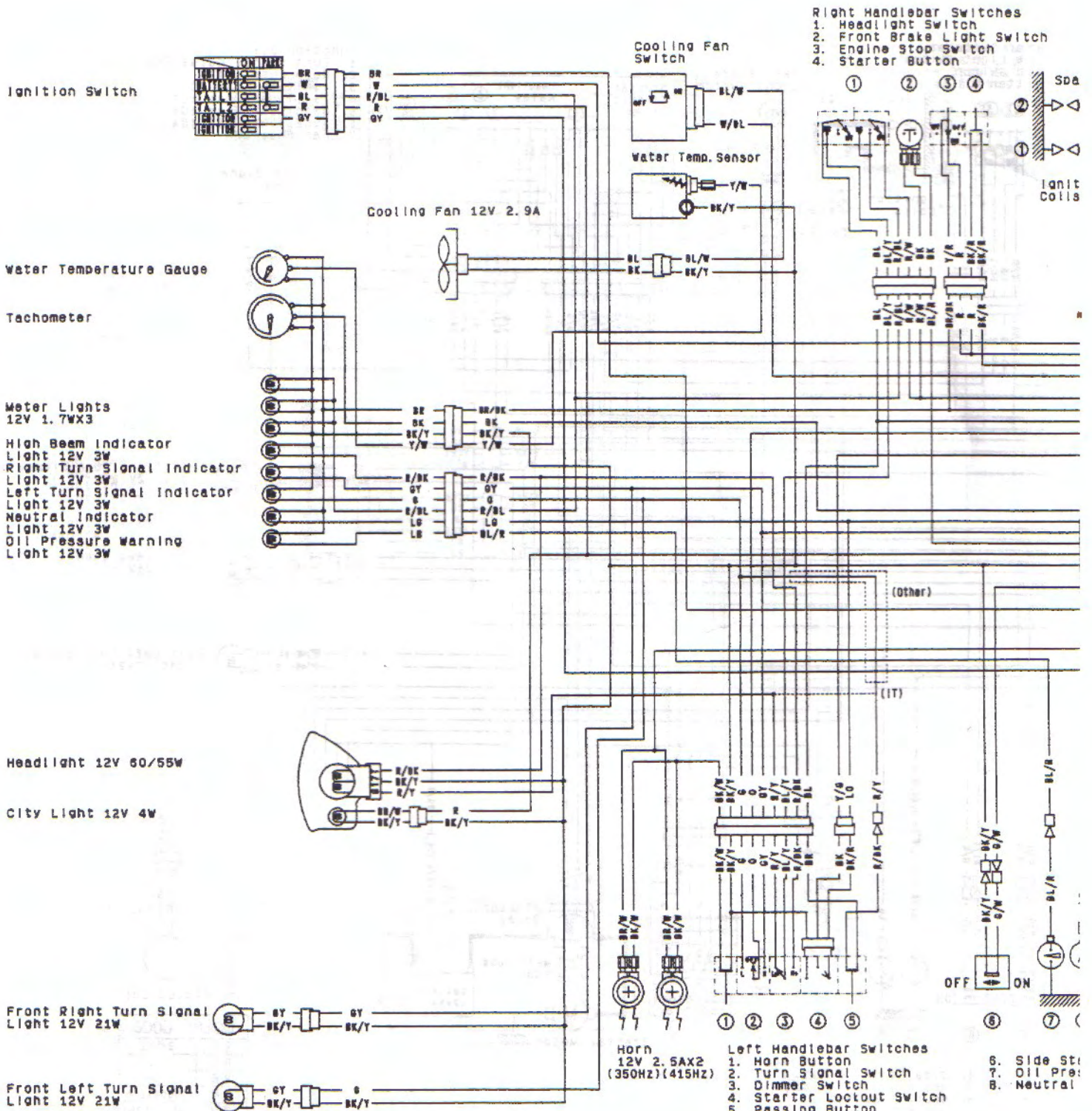

LEFT HANDLEBAR SWITCH CONNECTIONS

Horn Button	Turn Signal Switch	Dimmer Switch	Starter Lockout Switch
Color BK/WBK/Y	Color G O GY	Color R/Y BL/YR/BK	Color BK/Y BK BK/R
Push <input type="checkbox"/>	R <input type="checkbox"/>	LO <input type="checkbox"/>	Clutch Lever <input type="checkbox"/>
Released <input type="checkbox"/>	OFF (Push) <input type="checkbox"/>	HI <input type="checkbox"/>	Released <input type="checkbox"/>
	L <input type="checkbox"/>		Pulled in <input type="checkbox"/>

(IT): Italy Model
(Other): Other Than Italy Mod

Color	IGNITION SWITCH CONNECTIONS			
	Ignition	Battery	Ignition	Tails
OFF, LOCK	<input type="checkbox"/>	<input type="checkbox"/>	<input type="checkbox"/>	<input type="checkbox"/>
ON	<input type="checkbox"/>	<input type="checkbox"/>	<input type="checkbox"/>	<input type="checkbox"/>
P(PARK)	<input type="checkbox"/>	<input type="checkbox"/>	<input type="checkbox"/>	<input type="checkbox"/>

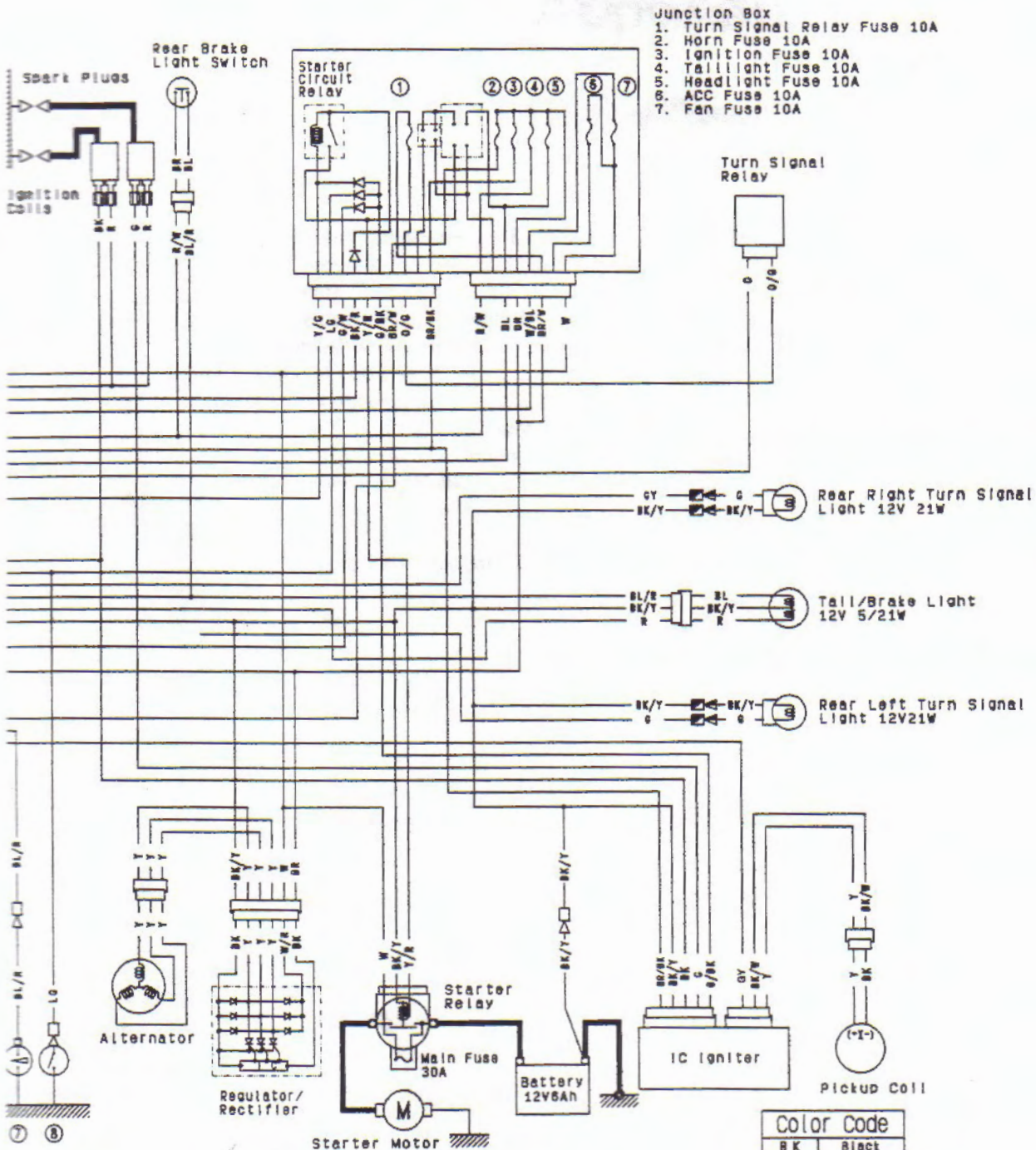

- Junction Box
1. Turn Signal Relay Fuse 10A
 2. Horn Fuse 10A
 3. Ignition Fuse 10A
 4. Taillight Fuse 10A
 5. Headlight Fuse 10A
 6. ACC Fuse 10A
 7. Fan Fuse 10A

Head Stand Switch
Pressure Switch
Neutral Switch

Models

ACTIONS

Left	Tail 2
BL	R
○	○
○	○
○	○

RIGHT HANDLEBAR SWITCH CONNECTIONS

Headlight Switch				Front Brake Light Switch		Engine Stop Switch		Starter Button					
Color	BL/Y	BL	R/BL	R/W	Color	BK	BK	Color	Y/R	R	Color	BK/R	BK/R
OFF	○	○	○	○	Brake Lever	○	○	OFF	Y/R	○	Push	○	○
0	○	○	○	○	Pulled in	○	○	Released	○	○	Released	○	○
ON	○	○	○	○	Released	○	○	RUN	○	○	○	○	○

Color Code

BK	Black
BL	Blue
BR	Brown
CH	Chocolate
DG	Dark Green
G	Green
GY	Gray
LB	Light Blue
LG	Light Green
O	Orange
P	Pink
PU	Purple
R	Red
W	White
Y	Yellow

Clutch Lever Holder Clamp Bolt
Clutch Lever Pivot Nut
Shift Pedal Bolt

Nut, Bolt, and Fastener Tightness

Appendix

Table of Contents

Additional Considerations for Racing.....	*
Carburetor.....	*
Spark Plug.....	*
Spark Plug Inspection	*
Troubleshooting Guide.....	*
General Lubrication	*
Lubrication	*
Nut, Bolt, and Fastener Tightness	16-2
Tightness Inspection	16-2
Unit Conversion Table.....	*

* : Refer to Base Manual

Quick Reference

Nut, Bolt, and Fastener Tightness

Clutch Lever Holder Clamp Bolts
Clutch Lever Pivot Nut
Shaft Pedal Bolt

Tightness Inspection

- Check the tightness of the bolts and nuts listed here. Also, check to see that each cotter pin is in place and in good condition.

NOTE

○ Check the engine fastener tightness when the engine is cold (at room temperature).

- ★ If there are loose fasteners, first loosen by ½ turn, then retorque them to the specified torque following the specified tightening sequence. Refer to the appropriate chapter for torque specifications. If torque specifications are not in the appropriate chapter, see the basic torque table (see Torque and Locking Agent in the General Information chapter).
- ★ If cotter pins are damaged, replace them with new ones.

Nut, Bolt, and Fastener to be checked

Wheels:

Front Axle Nut
Front Axle Clamp Bolts
Rear Axle Nut and Cotter Pin

Final Drive:

Chain Adjusting Nuts and Locknuts

Brakes:

Front Master Cylinder Clamp Bolts
Brake Lever Pivot Nut
Rear Master Cylinder Mounting Bolts
Brake Pedal Bolt
Brake Push Rod Clevis Cotter Pin
Caiiper Mounting Bolts

Suspension:

Front Fork Clamp Bolts
Rear Shock Absorber Mounting Nuts
Swing Arm Pivot Nut
Rocker Arm Pivot Nut
Tie-rod Bolts and Nuts

Steering:

Stem Head Bolts
Handlebar Mounting Bolts
Handlebar Holder Mounting Bolts

Frame:

Front Fender Mounting Bolts
Grab Bar Mounting Bolts
Rear Frame Mounting Bolts
Center Stand Pivot Bolts
Side Stand Pivot Nut
Side Stand Bracket Bolts
Footpeg Pivot Clips
Footpeg Bracket Mounting Bolts

Engine:

Engine Mounting Bolts and Nuts
Engine Mounting Bracket Bolts and Nuts
Exhaust Pipe Holder Nuts
Muffler Mounting Nuts
Muffler Clamp Bolts

MODEL APPLICATION

Year	Model	Beginning Frame No.
1990	EX250-H1	JKAEXMH1 □ LA000001, or EX250H-000001
1991	EX250-H2	JKAEXMH1 □ MA008801, or EX250H-008801
1992	EX250-H3	JKAEXMH1 □ NA025001, or EX250H-025001
1993	EX250-H4	EX250H-033001
1994	EX250-H5	JKAEXMH1 □ RA050001, or EX250H-050001
1996	EX250-H7	JKAEXMH1 □ TA060001, or EX250H-060001

□ :This digit in the frame number changes from one machine to another.



KAWASAKI HEAVY INDUSTRIES, LTD.
Consumer Products Group

Part No. 99924-1129-54

Printed in Japan