

**KX85  
KX100**

**Motorcycle**

---

# **OWNER'S MANUAL**

---

 **Read this manual carefully. It contains safety information.**

**Kawasaki**

---

---

# Quick Reference Guide

This Quick Reference Guide will assist you in finding the information you're looking for.

**GENERAL INFORMATION**

**MAINTENANCE AND ADJUSTMENT**

**TROUBLESHOOTING GUIDE**

**TUNING**

**STORAGE**

A Table of Contents is included after the Foreword.

### **IMPORTANT INFORMATION**

- This vehicle is designed for the operator only, no passengers.
- This vehicle is a competition model only and was not manufactured for use on public streets, roads or highways.
- The use of this vehicle should be limited to participation in sanctioned competition events upon a closed course.
- This vehicle should not be used for general off-road recreational riding.
- Read owner's manual.

Whenever you see the symbols shown below, heed their instructions! Always follow safe operating and maintenance practices.

** DANGER**

**DANGER indicates a hazardous situation which, if not avoided, will result in death or serious injury.**

** WARNING**

**WARNING indicates a hazardous situation which, if not avoided, could result in death or serious injury.**

**NOTICE**

**NOTICE is used to address practices not related to personal injury.**

**NOTE**

○ *NOTE indicates information that may help or guide you in the operation or service of the vehicle.*

**IMPORTANT NOTICE**

THIS VEHICLE IS A COMPETITION MODEL ONLY AND WAS NOT MANUFACTURED FOR, NOR SHOULD IT BE USED ON, PUBLIC STREETS, ROADS, OR HIGHWAYS. THE USE OF THIS VEHICLE SHOULD BE LIMITED TO PARTICIPATION IN SANCTIONED COMPETITION EVENTS UPON A CLOSED COURSE. THIS VEHICLE SHOULD NOT BE USED FOR GENERAL OFF-ROAD RECREATIONAL RIDING. READ OWNER'S MANUAL.

** WARNING**

**THIS VEHICLE SHOULD NOT BE USED FOR GENERAL OFF-ROAD RECREATIONAL RIDING.**

**DISCLAIMER OF WARRANTY**

**This motorcycle is sold AS IS, with all faults, obvious or concealed and there are NO WARRANTIES expressed or implied.**

**Including warranties of MERCHANTABILITY or FITNESS FOR PURPOSE.**

**The purchaser accepts all responsibilities concerning quality, performance, cost of service and/or necessary repairs.**

**Motorcycle Noise Emission Control  
Information**

This motorcycle is designed for closed course competition use only. It does not conform to U.S. EPA motorcycle noise standards.

***NOTICE***

Off-road motorcycling is a wonderful sport, and we hope you will enjoy it to the fullest. However, if improperly conducted, this sport has the potential to cause environmental problems as well as conflicts with other people. Responsible use of your off-road motorcycle will ensure that these problems and conflicts do not occur. **TO PROTECT THE FUTURE OF YOUR SPORT, MAKE SURE YOU USE YOUR MOTORCYCLE LEGALLY, SHOW CONCERN FOR THE ENVIRONMENT, AND RESPECT THE RIGHTS OF OTHER PEOPLE.**

 **WARNING**

The engine exhaust from this product contains chemicals known to the State of California to cause cancer, birth defects or other reproductive harm.

# FOREWORD

Congratulations on your choosing this Kawasaki motorcycle. Your new motorcycle is the product of Kawasaki's advanced engineering, exhaustive testing, and continuous striving for a superior lightweight, high-performance machine with superb handling and stability for racing and sporting use.

Your new KX is a highly tuned competition machine for participation in racing events. As with any mechanical device, proper care and maintenance are important for trouble-free operation and top performance. This manual is written to enable you to keep your KX properly tuned and adjusted.

Due to improvements in design and performance made during production, in some cases there may be minor discrepancies between the actual vehicle and the illustrations and text in this manual.

**KAWASAKI HEAVY INDUSTRIES, LTD.**  
**Motorcycle & Engine Company**

## IMPORTANT NOTE TO PARENTS ABOUT SAFE RIDING

This is a high performance off-road motorcycle designed for experienced young riders. It is not suitable for beginners. Your youngster's safety will depend on your commitment to always provide a safe riding environment and a properly maintained vehicle. As with any moving vehicle there are possible safety risks; be sure to heed these precautions.

1. Always equip your child with suitable protective gear and riding apparel. Be sure he or she always wears a helmet, eye protection, gloves, long pants, and a long-sleeved shirt while riding.
2. Never allow your child to carry a passenger. This motorcycle is designed for an OPERATOR ONLY.
3. This motorcycle is designed for off-road riding and should never be operated on public roads or paved surfaces.
4. Always obey local off-road riding laws and regulations. Obtain permission to ride on private property.
5. You, the parent (and most likely "riding instructor/mechanic" as well), must be familiar with motorcycle controls and maintenance requirements plus riding techniques. Read and understand the owner's manual provided with the motorcycle. Review all instructions and warnings with your child.
6. You must determine your child's readiness to ride this off-road motorcycle. Your child should already be familiar with motorcycle controls (location and function) and basic riding techniques. Your child should also be physically large and strong enough to be able to straddle the motorcycle and hold it up, plus be able to pick it up if it is on its side.
7. Before allowing your child to enter competition events, you must determine that he or she has the necessary riding skills and physical/emotional maturity.
8. Your child's safety depends in part on the good mechanical condition of the motorcycle. Be sure to follow the maintenance and adjustment requirements contained in the Periodic Maintenance Chart, Daily Pre-ride Inspection, and After-Race Check Points. Be sure your child understands the importance of checking all items thoroughly before riding the motorcycle. Also, familiarity with the motorcycle is important should a problem occur far from help.
9. Do not allow your child to ride unsupervised. He or she should always ride in the company of an experienced adult.
10. Encourage your child not to ride beyond his or her skill level or faster than conditions safely allow. Have them practice advanced riding maneuvers under controlled conditions.
11. Tell someone where you and your child are planning to ride and when you intend to return. Discuss the ride with your child before you leave so he or she will know in advance what riding techniques may be necessary to negotiate the terrain safely. If you are not familiar with the area, lead the way and reduce your speed.



---

# TABLE OF CONTENTS

---

<b>SPECIFICATIONS</b> .....	9	Exhaust System .....	87
<b>GENERAL INFORMATION</b> .....	15	Drive Chain.....	91
Location of Labels .....	15	Handlebar .....	97
Location of Parts .....	18	Brakes .....	100
Side Stand .....	22	Steering .....	105
Fuel .....	23	Front Suspension .....	108
Fuel Requirement:.....	24	Rear Suspension (UNI-TRAK®).....	118
Kick Pedal .....	27	Wheels .....	125
Starting the Engine.....	27	Hoses Inspection.....	128
Shifting Gears.....	29	Tightening Torques of Nuts and Bolts.....	129
Stopping the Motorcycle.....	30	Cleaning Your Motorcycle.....	134
Stopping the Engine .....	30	Lubrication .....	136
Break-In.....	31	<b>TROUBLESHOOTING GUIDE</b> .....	140
Daily Pre-Ride Checks .....	33	<b>TUNING</b> .....	147
After-Race Checks .....	35	Carburetor .....	147
<b>MAINTENANCE AND ADJUSTMENT</b> .....	36	Suspension.....	154
Periodic Maintenance Chart.....	36	Gearing.....	160
Transmission Oil.....	40	Special Care According to Track Conditions .	161
Cooling System .....	42	<b>OPTIONAL PARTS</b> .....	162
Spark Plug .....	47	<b>PRE-RACE CHECKS AND AFTER-RACE</b>	
Ignition Timing .....	49	<b>MAINTENANCE</b> .....	164
Air Cleaner .....	52	<b>STORAGE</b> .....	166
Throttle Cable.....	57	Before Storage .....	166
Carburetor .....	59	After Storage .....	167
Clutch .....	64	<b>ENVIRONMENTAL PROTECTION</b> .....	168
Piston .....	71	<b>WIRING DIAGRAM</b> .....	169

---

# SPECIFICATIONS

---

## DIMENSIONS

### Overall Length:

KX85C 1 830 mm (72.05 in.)

KX100F 1 920 mm (75.60 in.)

### Overall Width

765 mm (30.12 in.)

### Overall Height:

KX85C 1 100 mm (43.31 in.)

KX100F 1 150 mm (45.28 in.)

### Wheelbase:

KX85C 1 265 mm (49.80 in.)

KX100F 1 310 mm (51.57 in.)

### Road Clearance:

KX85C 290 mm (11.42 in.)

KX100F 330 mm (12.99 in.)

### Curb Mass:

KX85C 75 kg (165 lb)

KX100F 77 kg (170 lb)

### Fuel Tank Capacity

5.0 L (1.3 US gal)

## 10 SPECIFICATIONS

### ENGINE

Type	2-stroke, single-cylinder, piston reed valve, liquid-cooled
Bore × Stroke:	
KX85C	48.5 × 45.8 mm (1.91 × 1.80 in.)
KX100F	52.5 × 45.8 mm (2.07 × 1.80 in.)
Displacement:	
KX85C	84 cm <sup>3</sup> (5.1 cu in.)
KX100F	99 cm <sup>3</sup> (6.04 cu in.)
Compression Ratio:	
Low Speed:	
KX85C	10.9:1
KX100F	10.2:1
High Speed:	
KX85C	9.0:1
KX100F	8.7:1
Port Timing:	
Intake:	
Open	Full Open
Close	—
Scavenging:	
Open:	
KX85C	63.8° BBDC
KX100F	62.8° BBDC

Close:

KX85C

63.8° ABDC

KX100F

62.8° ABDC

Exhaust:

Open:

KX85C

(Low speed) 79° BBDC, (High speed) 93.6° BBDC

KX100F

(Low speed) 81.7° BBDC, (High speed) 93.6° BBDC

Close:

KX85C

(Low speed) 79° ABDC, (High speed) 93.6° ABDC

KX100F

(Low speed) 81.7° ABDC, (High speed) 93.6° ABDC

Fuel System

Carburetor, KEIHIN PWK28

Starting System

Primary Kick

Ignition System

CDI

Ignition Timing:

KX85C

12° BTDC @11 320 r/min (rpm)

KX100F

12° BTDC @12 640 r/min (rpm)

Lubrication System

PETROL MIX (32:1)

Spark Plug

NGK R6252K-105

Spark Plug Terminal

Solid-post

**TRANSMISSION**

Transmission Type

6-speed, Constant Mesh, Return Shift

Clutch Type

Wet, Multi Disc

Driving System

Chain Drive

## 12 SPECIFICATIONS

### Gear Ratio:

1st	2.538 (33/13)
2nd	1.875 (30/16)
3rd	1.500 (27/18)
4th	1.250 (25/20)
5th	1.090 (24/22)
6th	0.956 (22/23)

### Primary Reduction Ratio

3.400 (68/20)

### Final Reduction Ratio:

KX85C	3.571 (50/14)
KX100F	3.923 (51/13)

### Overall Drive Ratio:

KX85C	11.607 (Top gear)
KX100F	12.758 (Top gear)

### Transmission Oil:

Grade	API SG, SH, SJ, SL or SM with JASO MA, MA1 or MA2
Viscosity	SAE 10W-40
Amount	0.7 L (0.74 US qt)

## FRAME

Type	Tubular, semi-double cradle
Steering Angle	45° to either side
Caster	29°

Trail:

KX85C	97 mm (3.82 in.)
KX100F	108 mm (4.25 in.)

Tire Size/Type:

Front:

KX85C	70/100-17 40M/DUNLOP MX51F
KX100F	70/100-19 42M/DUNLOP MX51F

Rear:

KX85C	90/100-14 49M/DUNLOP MX51
KX100F	90/100-16 52M/DUNLOP MX51

Rim Size:

Front:

KX85C	17 × 1.40
KX100F	19 × 1.40

Rear:

KX85C	14 × 1.60
KX100F	16 × 1.85

Suspension:

Front	Telescopic fork (upside-down)
Rear	Uni-trak® swingarm

Front Suspension Travel 275 mm (10.83 in.)

Rear Wheel Travel 275 mm (10.83 in.)

## 14 SPECIFICATIONS

### Front Fork Oil:

Type

Kawasaki Fork Oil KHL15-10

Amount

295 ~ 325 mL (9.97 ~ 11.0 US oz.)

### **BRAKES**

#### Type:

Front

Single disc

Rear

Single disc

#### Brake Fluid Grade:

Front

DOT3 or DOT4

Rear

DOT4

Specifications are subject to change without notice.

---

# GENERAL INFORMATION

---

---

## Location of Labels

---

All warning labels which are on your vehicle are repeated here. Read labels on your vehicle and understand them thoroughly. They contain information which is important for your safety and the safety of anyone else who may operate your vehicle. Therefore, it is very important that all warning labels be on your vehicle in the locations shown. If any label is missing, damaged, or worn, get a replacement from your Kawasaki dealer and install it in the correct position.

### NOTE

- *The sample warning labels in this section have part numbers to help you and your dealer obtain the correct replacement.*

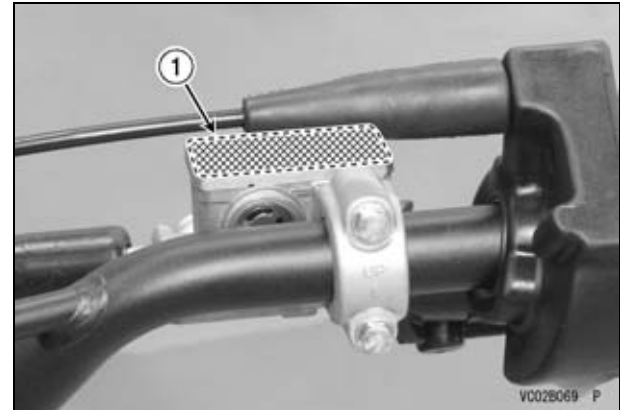

**1. Brake Fluid (Front)**



## 16 GENERAL INFORMATION

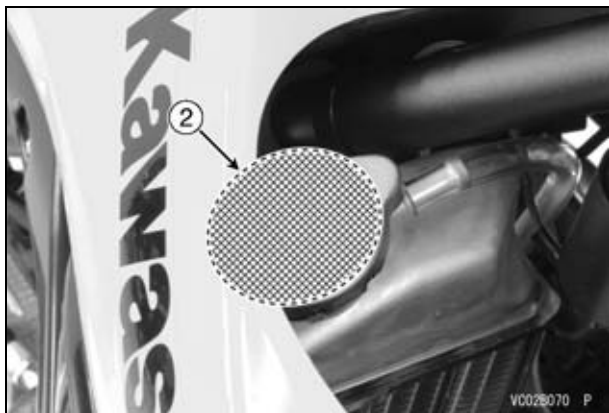

- 
2. Radiator Cap Danger
  3. Rear Shock Absorber Warning
  4. Gasoline-Engine Oil Mixing Ratio
  5. Disclaimer of Warranty
  6. Noise Emission Control Information
  7. Important Information

1)

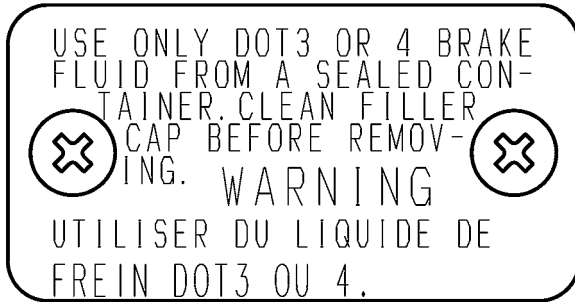

VC02074B S

2)



VC02138B S

3)



BD03238C2 C

4)

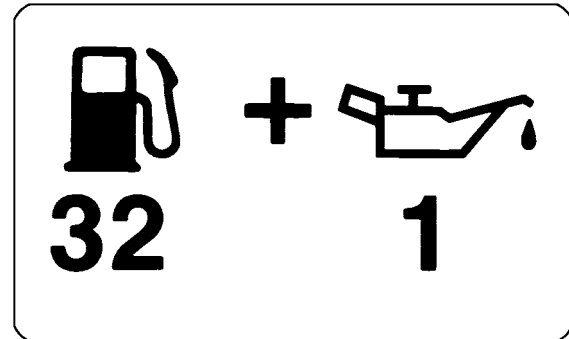

56030-1230

VC02093B S

## 18 GENERAL INFORMATION

5)

6)

7)

### **IMPORTANT INFORMATION**

- This vehicle is designed for the operator only, no passengers.
- This vehicle is a competition model only and was not manufactured for use on public streets, roads or highways.
- The use of this vehicle should be limited to participation in sanctioned competition events upon a closed course.
- This vehicle should not be used for general off-road recreational riding.
- Read owner's manual.

56071-0028

VC02076B S

---

## Location of Parts

---

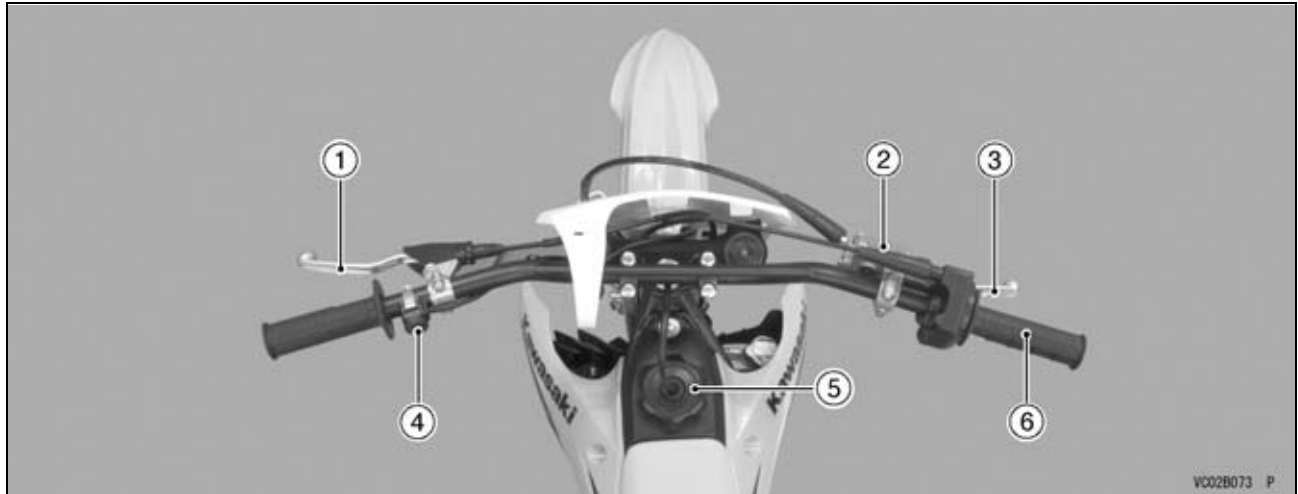

- 1. Clutch Lever
- 2. Front Brake Fluid Reservoir
- 3. Front Brake Lever

- 4. Engine Stop Button
- 5. Fuel Tank Cap
- 6. Throttle Grip

## 20 GENERAL INFORMATION

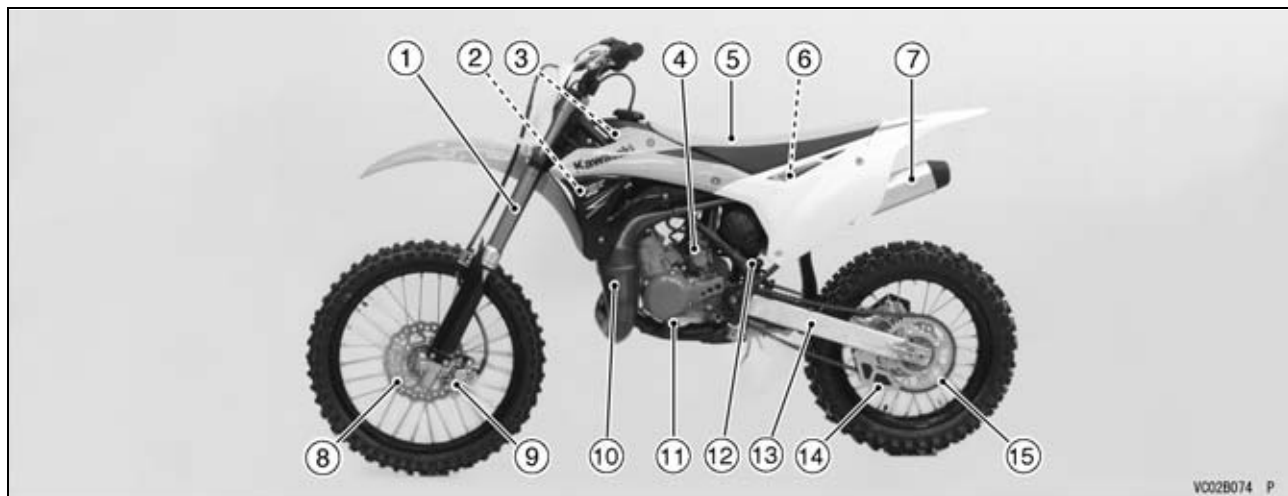

VO02B074 P

1. Front Fork
2. Radiator
3. Fuel Tank
4. Carburetor
5. Seat
6. Air Cleaner Element
7. Muffler
8. Front Brake Disc

9. Front Brake Caliper
10. Expansion Chamber
11. Shift Pedal
12. Rear Shock Absorber
13. Swingarm
14. Chain Guide
15. Drive Chain

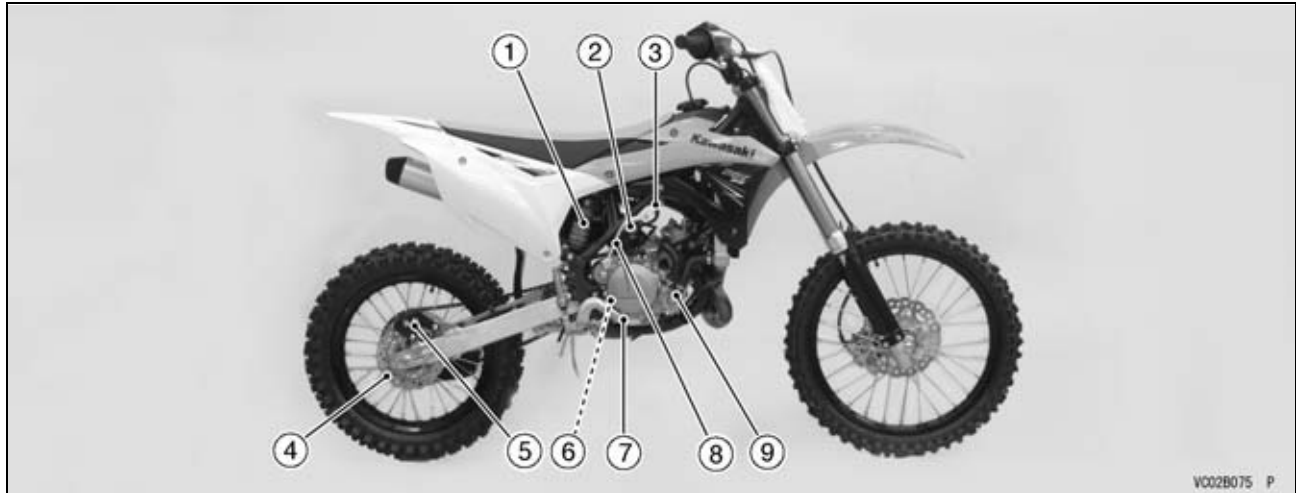

1. Rear Shock Absorber Gas Reservoir
2. Rear Brake Fluid Reservoir
3. Fuel Tap
4. Rear Brake Disc
5. Rear Brake Caliper

6. Transmission Oil Level Inspection Window
7. Rear Brake Pedal
8. Kick Pedal
9. Water Pump Cover

## 22 GENERAL INFORMATION

### Side Stand

Support the motorcycle with the provided side stand. Install the upper end of the side stand into the hole at the rear of the left footpeg.

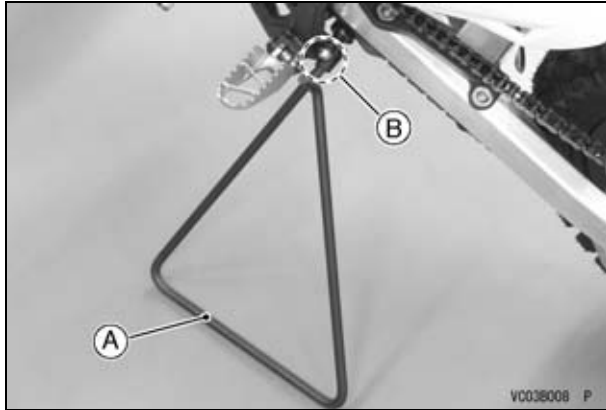

- A. Side Stand
- B. Hole

### **⚠ WARNING**

Riding with the side stand can cause a crash resulting in injury. Do not start the engine or attempt to ride the motorcycle when the side stand is installed.

### NOTE

- Support the motorcycle with a suitable stand to perform maintenance or adjustment procedures.

---

## Fuel

---

The Kawasaki KX is equipped with a 2-stroke engine that requires a gasoline-oil mixture.

### Fuel Tank Capacity

5.0 L (1.3 US gal)
--------------------

To open the fuel tank cap, pull out the breather hose from the hole in the steering shaft, and turn the tank cap counterclockwise.

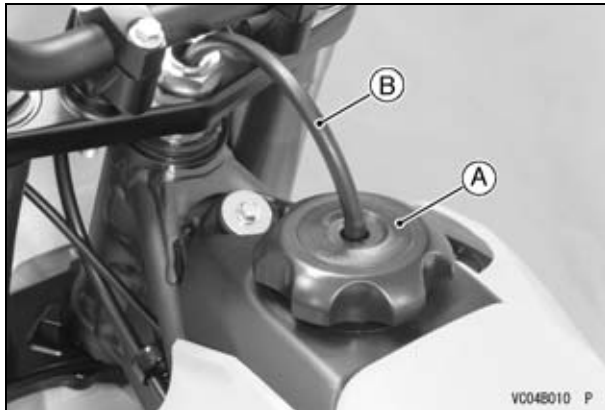

A. Fuel Tank Cap  
B. Breather Hose

Avoid filling the tank in the rain or where heavy dust is blowing so that the fuel does not get contaminated.

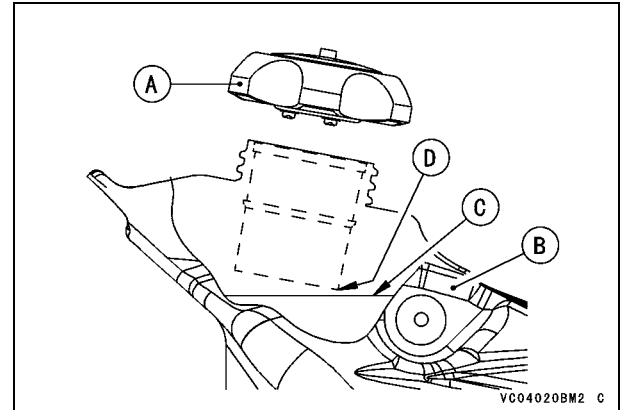

A. Fuel Tank Cap  
B. Fuel Tank  
C. Top Level  
D. Filler Neck



## 24 GENERAL INFORMATION

### **WARNING**

Gasoline is extremely flammable and can be explosive under certain conditions, creating the potential for serious burns. Always stop the engine and do not smoke. Make sure the area is well ventilated and free from any source of flame or sparks; this includes any appliance with a pilot light. Never fill the tank completely to the top. As the fuel expands in a warm tank, it may overflow through the vents in the tank cap. After refueling, make sure the fuel tank cap is closed securely. If gasoline is spilled on the fuel tank, wipe it off immediately.

### **Fuel Requirement:**

#### *Fuel Type*

Use clean, fresh unleaded gasoline with a minimum Antiknock Index of 90. The Antiknock Index is posted on service station pumps in the U.S.A. The octane rating of a gasoline is a measure of its resistance to detonation or “knocking”. The Antiknock Index is an average of the Research Octane Number (RON) and the Motor Octane Number (MON) as shown in the table below.

Octane Rating Method	Minimum Rating
Antiknock Index $\frac{(\text{RON} + \text{MON})}{2}$	90

### **NOTICE**

If engine “knocking” or “pinging” occurs, use a different brand of gasoline of a higher octane rating.  
If this condition is allowed to continue it can lead to severe engine damage.  
Gasoline quality is important. Fuels of low quality or not meeting standard industry specifications may result in unsatisfactory performance. Operating problems that result from the use of poor quality or nonrecommended fuel may not be covered under your warranty.

#### *Fuels Containing Oxygenates*

Gasoline frequently contains oxygenates (alcohols and ethers) especially in areas of the U.S. and the Canada which are required to sell such reformulated fuels as part of a strategy to reduce exhaust emissions.

The types and volume of fuel oxygenates approved for use in unleaded gasoline by the U.S. Environmental Protection Agency include a broad range of alcohols and ethers, but only two components have seen any significant level of commercial use.

Gasoline/Alcohol Blends - Gasoline containing up to 10% ethanol (alcohol produced from agricultural products such as corn), also known as “gasohol” is approved for use.

**NOTICE**

**Avoid using blends of unleaded gasoline and methanol (wood alcohol) whenever possible, and never use “gasohol” containing more than 5% methanol. Fuel system damage and performance problems may result.**

Gasoline/Ether Blends - The most common ether is methyl tertiary butyl ether (MTBE). You may use gasoline containing up to 15% MTBE.

**NOTE**

- *Other oxygenates approved for use in unleaded gasoline include TAME (up to 16.7%) and ETBE (up to 17.2%). Fuel containing these oxygenates can also be used in your Kawasaki.*

**NOTICE**

**Never use gasoline with an octane rating lower than the minimum specified by Kawasaki.**

**Never use “gasohol” with more than 10% ethanol, or more than 5% methanol. Gasoline containing methanol must also be blended with cosolvents and corrosion inhibitors.**

**Certain ingredients of gasoline may cause paint fading or damage. Be extra careful not to spill gasoline or gasoline oxygenate blends during refueling.**

**When not operating your Kawasaki for 30 to 60 days, mix a fuel stabilizer (such as STA-BIL) with the gasoline in the fuel tank. Fuel stabilizer additives inhibit oxidation of the fuel which minimizes gummy deposits.**

**Never store this product with “gasohol” in the fuel system. Before storage it is recommended that you drain all fuel from the fuel system. See the Storage section in this manual.**

**2-Stroke Oil**

Oil must be mixed with the gasoline to lubricate the piston, cylinder, crankshaft bearings, and connecting rod bearings.

## 26 GENERAL INFORMATION

### Recommended Oil

Kawasaki Performance 2-Stroke Racing Oil\*  
or equivalent 2-stroke engine lubricant

\*Kawasaki Performance Oils and Lubricants have been specifically engineered for your vehicle. Consistent use of these products meets or exceeds service requirements and can help to extend the life of your Kawasaki.

### Gasoline-Engine Oil Mixing Ratio

32:1 (Gasoline:Engine Oil)

A 32-to-1 mixture is about 31 mL of oil per liter of gasoline or 4 fluid ounces of oil per gallon of gasoline.

### ***NOTICE***

**Do not use vegetable and mineral oils. Too much oil will cause excessive smoking and spark plug fouling. Too little oil will cause engine damage or premature wear.**

To prepare the gasoline-oil mixture, pour the oil and half of the gasoline into a container first and stir thoroughly. Then, add the rest of the gasoline and stir the mixture well.

### **NOTE**

- *At low temperature, oil will not easily mix with gasoline. Take time to ensure a well-blended mixture.*
- *The lubricative quality of the gasoline-oil mixture deteriorates rapidly; therefore, prepare a fresh mixture for each day of operation.*

---

## Kick Pedal

---

This motorcycle is equipped with a primary kick starting system. When the clutch lever is pulled, the motorcycle can be started with the transmission in any gear.

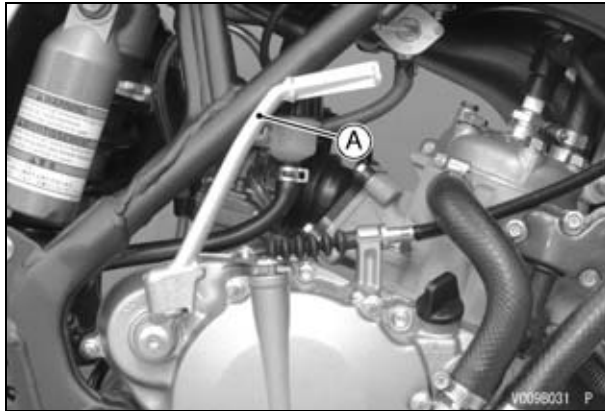

A. Kick Pedal

---

## Starting the Engine

---

- Turn the fuel tap lever to the “ON” position.

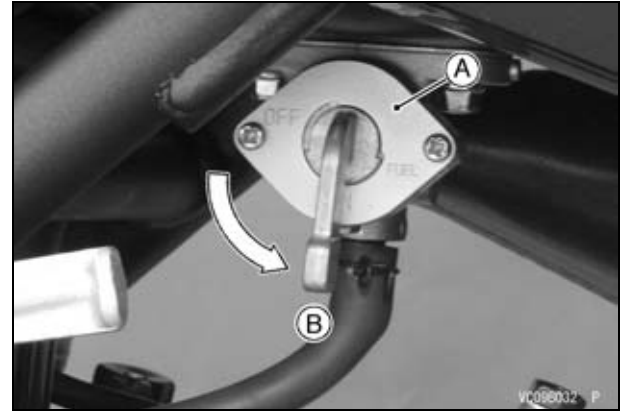

- A. Fuel Tap
- B. ON position

- Shift the transmission into neutral.

### **⚠ WARNING**

Riding with the side stand can cause a crash resulting in injury. Do not start the engine or attempt to ride the motorcycle when the side stand is installed.

### NOTICE

This motorcycle is designed for competition use only. Therefore, the radiator does not incorporate a coolant reserve tank or cooling fan. Prolonged idling of the engine with no airflow through the radiator can cause coolant loss and engine overheating resulting in possible engine damage. Any riding conditions that increase engine temperature will further reduce idling time before coolant loss occurs. These conditions include high ambient temperature, sandy or muddy terrain, or other conditions causing high engine loads at low speeds. Furthermore, warming the engine up excessively before operation, or leaving idling with the hot engine temperature after operation results in the engine overheating, too.

#### When engine is cold -

- Pull up the choke knob.



#### A. Choke Knob

- Kick the engine over, leaving the throttle closed.
- Even after the engine has started, do not push back immediately the choke knob until the engine is thoroughly warmed up.

#### NOTE

- *If the engine is flooded, kick it over with the throttle fully open until it starts.*
- *When the clutch lever is pulled, the motorcycle can be started with the transmission in any gear.*

#### When engine is already warm -

- When the engine is already warm or on hot days, open the throttle part way instead of using the choke knob.

---

## Shifting Gears

---

This motorcycle is equipped with a 6-speed “return shift” transmission. The neutral is located halfway between 1st and 2nd gear. “Return shift” means that when shifting up or down, each gear must be engaged before the next higher or lower gear may be selected.

- To engage 1st gear from the neutral position, pull in the clutch lever and push down on the shift pedal, gently release the clutch lever, then release the shift pedal.
- To shift up to the next gear, pull in the clutch lever, lift the shift pedal with your toes, gently release the clutch lever, and then release the shift pedal.
- To shift down to the next gear, pull in the clutch lever, push the shift pedal down as far as it will go, gently release the clutch lever, then release the shift pedal.

### **NOTICE**

**When changing gears, press firmly on the shift pedal to ensure proper shifting. Careless, incomplete shifting can cause the transmission to jump out of gear and lead to engine damage.**

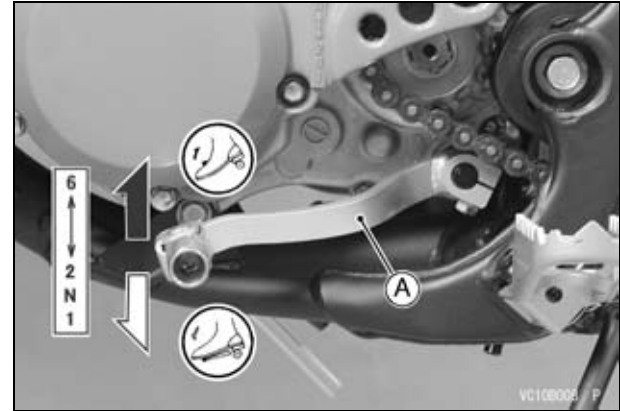

**A. Shift Pedal**

## 30 GENERAL INFORMATION

---

### Stopping the Motorcycle

---

For maximum deceleration, close the throttle and apply both front and rear brakes. Pull in the clutch lever as the motorcycle comes to a stop. Independent use of the front or rear brake may be advantageous in certain circumstances. Shift down progressively to ensure good engine response at all speeds.

---

### Stopping the Engine

---

- Shift the transmission into the neutral position.
- After racing the engine slightly, close the throttle completely and push the engine stop button.

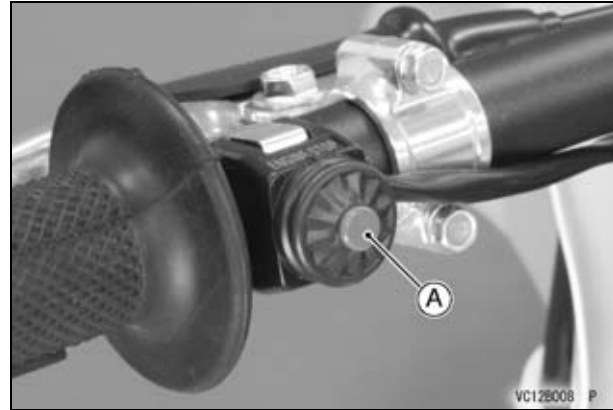

**A. Engine Stop Button**

- Turn the fuel tap lever to the “OFF” position.

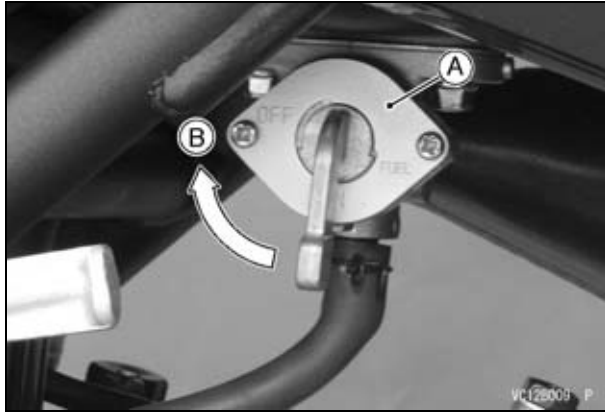

A. Fuel Tap  
B. OFF position

## Break-In

A brief break-in procedure must be carried out to obtain the proper operating clearances in the engine and transmission, which are necessary for performance and reliability.

### NOTICE

**For the first hour or 20 km (12 mile) of operation, run the engine at low and moderate engine speeds. See details below.**

### NOTE

- *The low-speed operation during the break-in period may cause carbon to build up on and foul the spark plug. If so, replace the standard spark plug with a hotter spark plug for the duration of the break-in period.*

### Recommended Spark Plug

Standard Plug	NGK R6252K-105
Hotter Plug	NGK BR9EVX

Break in the engine as follows.

1. Start the engine and let it idle until it is thoroughly warmed up.
2. Stop and let the engine cool completely.
3. Start the engine and ride the motorcycle for 10 minutes at moderate speed - **NEVER ACCELERATE HARD.**



## 32 GENERAL INFORMATION

4. Stop and let the engine cool completely. Be sure to check and adjust the chain slack and spoke tightness and carry out a general inspection.
5. Start the engine and ride the motorcycle for 20 minutes at moderate speed - **NEVER ACCELERATE HARD.**
6. Stop and let the engine cool completely. Check and adjust as in step 4. Then, drain the coolant, remove and inspect the cylinder head, cylinder and piston.

Piston: A scored piston skirt could lower engine performance or damage the cylinder wall. Scores on the cylinder wall should be smoothed with a **#400** to **#600** emery cloth.

Cylinder: Decarbonize the exhaust ports and the upper part of the cylinder, taking care not to damage the cylinder wall. Scores on the cylinder wall should be smoothed with a **#400** to **#600** emery cloth.

Cylinder Head: Remove the carbon inside the combustion chamber.

7. Install the removed parts.
8. Fill the radiator up to the bottom of the radiator filler neck with coolant. Before putting the motorcycle into operation, bleed the cooling system.
9. Start the engine and ride the motorcycle for 30 minutes at moderate speed - **NEVER ACCELERATE HARD.**
10. Stop and let the engine cool completely. Check and adjust as in step 4.
11. After the break-in procedure has been properly carried out, the motorcycle is ready for regular operation. Using the proper riding skills and techniques and avoiding recklessly high engine speeds will keep the engine trouble-free.

### NOTE

- *After break-in, install a new standard spark plug, and change the transmission oil.*
- *To keep optimum engine performance, replace the piston ring after break-in.*

## Daily Pre-Ride Checks

Check the following items each day before you ride. The time required is minimal, and habitual performance of these checks will help ensure a safe, reliable ride.

If any irregularities are found during these checks, refer to the appropriate section and take the action required to return the motorcycle to a safe operating condition.

### WARNING

**Failure to perform these checks before operation may result in serious damage or an accident. Always perform daily checks before operation.**

### DANGER

**Exhaust gas contains carbon monoxide, a colorless, odorless poisonous gas. Inhaling carbon monoxide can cause serious brain injury or death. DO NOT run the engine in enclosed areas. Operate only in a well-ventilated area.**

### Engine

Transmission Oil .....	No leakage Level correct
Coolant .....	No leakage Level correct (engine cold)
Radiator Cap .....	Properly installed
Spark Plug .....	Correctly torqued
Cylinder Head Nut .....	Correctly torqued
Cylinder Nut .....	Correctly torqued
Clutch .....	Functions properly
Carburetor .....	Properly tuned
Air Cleaner .....	Clean Apply oil to air cleaner element.

## 34 GENERAL INFORMATION

Muffler .....	Properly installed No damage
Engine Sprocket .....	Properly installed No wear or damage

### Frame

Tires .....	Overall condition good No wear or damage Pressure correct Air valve cap installed
Spokes .....	No looseness
Drive Chain .....	Overall condition good Chain slack correct Oil if necessary
Front and Rear Brakes .....	Function properly Lever and pedal play correct No fluid leakage
Throttle .....	Functions properly Throttle grip returns smoothly
Steering .....	Smooth but not loose from lock to lock No binding due to control cables
Front Fork .....	Functions properly No oil leakage
Rear Shock Absorber .....	Functions properly No oil leakage
Fuel Tank .....	Mounted securely No fuel leakage
Rear Sprocket .....	No wear or damage
Engine Stop Button .....	Functions properly
Nuts, Bolts, Fasteners .....	Properly tightened

---

## **After-Race Checks**

---

After racing, first clean the motorcycle (see page 134), then inspect the entire motorcycle with special attention to the air cleaner, carburetor, brakes, etc.

Carry out the general lubrication (see page 136) and make necessary adjustments.

# MAINTENANCE AND ADJUSTMENT

## Periodic Maintenance Chart

The maintenance and adjustments outlined in this chapter are easily carried out and must be done in accordance with the Periodic Maintenance Chart to keep the motorcycle in good running condition.

†: Replace, add, adjust, clean or torque if necessary.

R: Replace

K: Should be serviced by referring to the Service Manual or an authorized Kawasaki dealer.

### 1. Periodic Inspection (Engine Related Item)

OPERATION	FREQUENCY	After each race (or 2.5 hours)	Every 3 races (or 7.5 hours)	Every 5 races (or 12.5 hours)	Every 10 races (or 25 hours)	As required	See Page	
Clutch - adjust		●					64	
Clutch and friction plates - check †			●	R			68	
Throttle cable - adjust		●					57	
Spark plug - clean/regap †		●	R				47	
Air cleaner element - clean		●					54	
Air cleaner element - replace		When damaged						52
Carburetor - inspect/adjust		●					59	
Transmission oil - change			●				40	
Piston and piston ring - clean/check †			●	R			78, 79, 80	

## MAINTENANCE AND ADJUSTMENT 37

OPERATION	FREQUENCY	After each race (or 2.5 hours)	Every 3 races (or 7.5 hours)	Every 5 races (or 12.5 hours)	Every 10 races (or 25 hours)	As re- quired	See Page
Cylinder head and cylinder - inspect			●				–
<b>K</b> Exhaust valves - clean/check		●					–
Silencer - clean/check †		●					87
Silencer wool - change			●				87
Connecting rod small end bearing - check †			●		R		80
Kick and shift pedals - clean		●					–
Expansion chamber O-rings - replace			●				87
Engine sprocket - check †		●					95
Coolant - check †		●				R	43
Radiator hoses, connections - check †		●					42
<b>K</b> Reed valve - check †		●					–

## 38 MAINTENANCE AND ADJUSTMENT

### 2. Periodic Inspection (Chassis Related Item)

OPERATION	FREQUENCY	After each race (or 2.5 hours)	Every 3 races (or 7.5 hours)	Every 5 races (or 12.5 hours)	Every 10 races (or 25 hours)	As required	See Page	
Brake adjustment - check †		●					100	
Brake pads wear - check †				●			104	
Brake fluid level - check †			●				101	
<b>K</b> Brake fluid - change		Every 2 years						–
<b>K</b> Brake master cylinder cups and dust seals - replace		Every 2 years						–
<b>K</b> Brake caliper piston seals and dust seals - replace		Every 2 years						–
<b>K</b> Brake hoses - replace		Every 4 years						–
Spokes tightness and rim runout - check †		●					126, 127	
Drive chain - adjust		●					91	
Drive chain - lubricate		●					96, 139	
Drive chain wear - check †				●			93	
Chain slipper and guide - replace		When damaged						95
Front forks - inspect/clean		●					108	
<b>K</b> Front fork oil - change		1st time after 2 races. then every 5 races						–
Nuts, bolts, fasteners - check †		●					129	
Fuel system - clean		●					–	

## MAINTENANCE AND ADJUSTMENT 39

OPERATION	FREQUENCY	After each race (or 2.5 hours)	Every 3 races (or 7.5 hours)	Every 5 races (or 12.5 hours)	Every 10 races (or 25 hours)	As re- quired	See Page
Fuel hose - replace		Every 5 years					-
<b>K</b> Brake hoses, connections - check †		●					-
<b>K</b> Fuel hose, connections - check †		●					-
Steering play - check †		●					105
<b>K</b> Steering stem bearings - grease				●			-
Rear sprocket - check †				●			95
General lubrication - perform		●					136
<b>K</b> Wheel bearings - check †					●		-
<b>K</b> Swingarm and UNI-TRAK® linkage pivots - grease †				●			-
<b>K</b> Swingarm and UNI-TRAK® linkage pivots - check				●			-
<b>K</b> Rear shock oil - change		1st time after 2 races, then every 5 races					-



### Transmission Oil

In order for the transmission and clutch to function properly, maintain the transmission oil at the proper level, and change the oil periodically.

Not only do dirt and metal particles collect in the oil, but the oil itself loses its lubricative quality if used too long.

#### **⚠ WARNING**

**Motorcycle operation with insufficient, deteriorated, or contaminated transmission oil will cause accelerated wear and may result in engine or transmission seizure, accident, and injury. Check the oil level before each ride and change the oil according to the periodic maintenance chart in the Owner's Manual.**

#### *Oil Level Inspection*

- Place the motorcycle perpendicular to the ground.
- If the oil has just been changed, let the motorcycle sit a few minutes allowing the oil to settle.
- Check the transmission oil level with the motorcycle vertical through the oil level inspection window on the lower right side of the engine. The oil level should come up to the middle of the oil level inspection window.

#### **NOTE**

- If the oil level is too high, remove the excess oil using a syringe or other suitable device.
- If the oil level is too low, add the correct amount of oil through the oil filler cap opening. Use oil of the same type and brand as those of the one that is already in the engine.

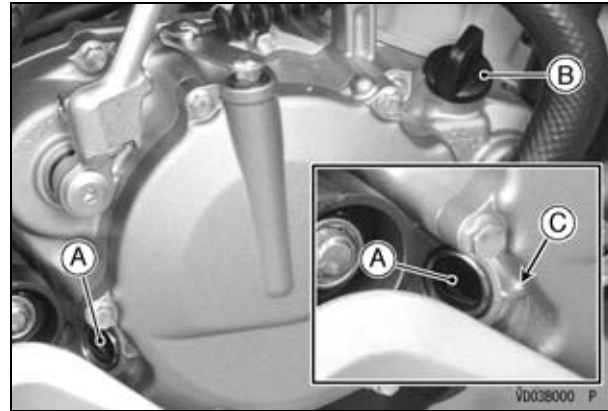

- A. Oil Level Inspection Window**
- B. Oil Filler Cap**
- C. Middle of Oil Level Inspection Window**

#### *Oil Change*

The transmission oil should be changed periodically to ensure long engine life.

- Warm up the engine thoroughly so that the oil will pick up any sediment and drain easily.
- Stop the engine, and place a container beneath it.
- Remove the oil filler cap.

- Remove the transmission oil drain bolt and the gasket, and position the vehicle perpendicular to the ground to allow all the oil to drain.

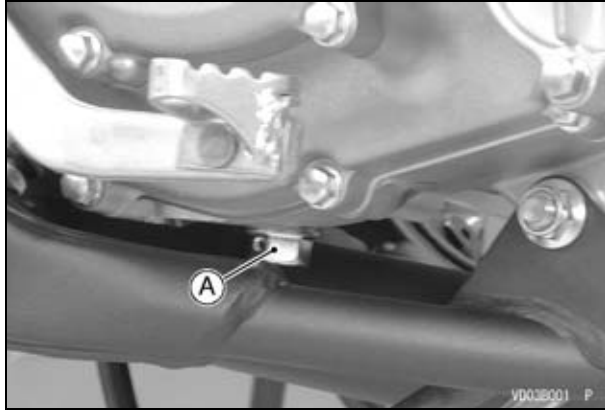

**A. Transmission Oil Drain Bolt and Gasket**

**⚠ WARNING**

**Transmission oil is a toxic substance. Dispose of used oil properly. Contact your local authorities for approved disposal methods or possible recycling.**

- Install the transmission oil drain bolt with its new gasket.
- Tighten it to the specified torque.

**Tightening Torque**

Transmission Oil Drain Bolt:  
20 N·m (2.0 kgf·m, 15 ft·lb)

- Pour in the specified amount of fresh transmission oil.
- Install the oil filler cap.
- Check the oil level after kicking the engine over 3 or 4 times.

**Recommended Transmission Oil**

Grade:

Kawasaki Performance 4-Stroke Motorcycle Oil\*  
Kawasaki Performance 4-Stroke Semi-Synthetic Oil\*

Kawasaki Performance 4-Stroke Full Synthetic Oil\*

or other 4-stroke oil with API SG, SH, SJ, SL, SM and JASO MA, MA1, MA2 rating

Viscosity:

SAE 10W-40

\* Kawasaki Performance Oils and Lubricants have been specifically engineered for your vehicle. Consistent use of these products meets or exceeds service requirements and can help to extend the life of your Kawasaki.

**Transmission Oil Total Amount**

0.7 L (0.74 US qt)

## 42 MAINTENANCE AND ADJUSTMENT

### NOTE

○ Do not add any chemical additive to the oil. Oils fulfilling the above requirements are fully formulated and provide adequate lubrication for both the engine and the clutch.

Although 10W-40 engine oil is the recommended oil for most conditions, the oil viscosity may need to be changed to accommodate atmospheric conditions in your riding area.

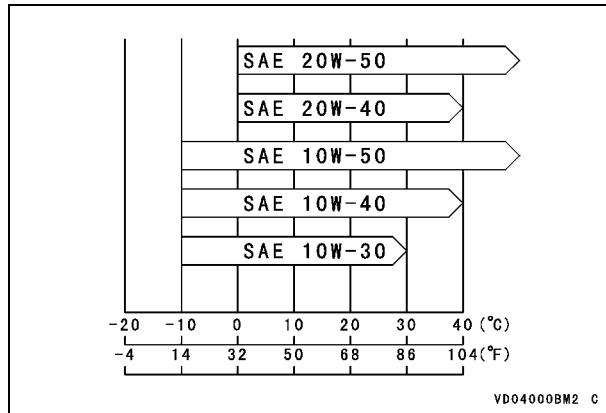

- Check the oil leakage.

## Cooling System

### Water Hoses

Check the water hoses for cracks or deterioration, and the connections for looseness in accordance with the Periodic Maintenance Chart.

### Radiator

Check the radiator fins for obstruction by insects or mud. Clean off any obstructions with a low-pressure stream of water.

### NOTICE

**Using high-pressure water, as from a car wash facility, could damage the radiator fins and impair the radiator's effectiveness.**

**Do not obstruct or deflect airflow by installing unauthorized accessories in front of the radiator.**

**Interference with the cooling airflow can lead to overheating and consequent engine damage.**

### Coolant

Coolant absorbs excessive heat from the engine and transfers it to the air through the radiator. If the coolant level becomes low, the engine overheats and may suffer severe damage. Check the coolant level each day before riding the motorcycle, and replenish coolant if the level is low.

**⚠ WARNING**

The cooling system can get extremely hot during normal operation and cause serious burns. Do not touch the radiator when it is hot, nor open the radiator cap. Hot coolant inside will cause severe burns.

**NOTICE**

Use coolant containing corrosion inhibitors made specifically for aluminum engines and radiators in accordance with the instruction of the manufacture. Soft or distilled water must be used with the antifreeze in the cooling system. If hard water is used in the system, it causes scale accumulation in the water passages, and considerably reduces the efficiency of the cooling system.

**NOTE**

- The coolant originally filled into the cooling system contains 50% of a permanent, ethylene-glycol-based antifreeze, has a freezing point of  $-35^{\circ}\text{C}$  ( $-31^{\circ}\text{F}$ ) and a green appearance.

**Coolant Level Inspection**

- Situate the motorcycle perpendicular to the ground until the radiator cap is level to the ground, so that the radiator cap is located uppermost

in order to exhaust the air accumulated in the radiator.

- Remove the radiator cap in two steps.
- First, turn the cap counterclockwise to the first stop and wait there for a few seconds.
- Then, push down and turn the cap further in the same direction and remove it.



**A. Radiator Cap**

- Check the coolant level in the radiator. The coolant should come up to the bottom of the radiator filler neck.

**NOTE**

- Check the coolant level when the engine is cold (room or ambient temperature).

## 44 MAINTENANCE AND ADJUSTMENT

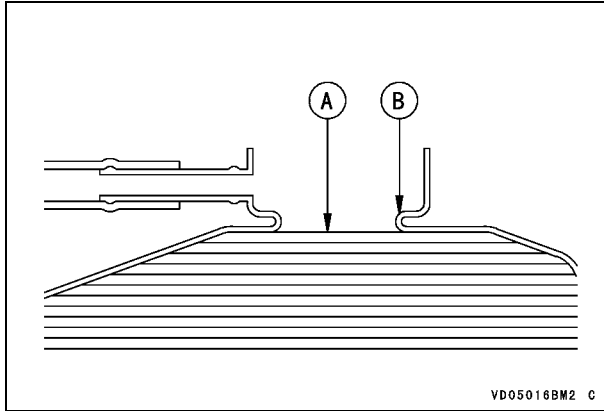

### A. Coolant Level

### B. Radiator Filler Neck

- If the coolant level is low, add coolant through the radiator filler opening to the bottom of the radiator filler neck.

### Recommended Coolant Mixed Ratio

Soft water 50%, coolant 50%

### Recommended Coolant Type

Permanent type of antifreeze (soft water and ethylene glycol plus corrosion and rust inhibitor chemicals for aluminum engines and radiators)

### Coolant Total Amount

0.57 L (0.60 US qt)

- Install the radiator cap in two steps.
- First, turn the cap clockwise to the first stop.
- Then, push down and turn the cap further in the same direction.

### Coolant Change

The coolant should be changed periodically to ensure long engine life.

- Wait for the engine to cool completely.
- Situate the motorcycle perpendicular to the ground until the radiator cap is level to the ground.
- Drain the coolant from the engine and radiator as follows.
- Place a container under the coolant drain bolts at the water pump cover and right side of the cylinder.
- Remove the radiator cap in two steps (see Coolant Level Inspection in this section).
- Remove the coolant drain bolts and the gaskets.

**NOTICE**

Immediately wash away any coolant that spills on the frame, engine, or wheel.

**⚠ WARNING**

Coolant on tires will make them slippery and can cause loss of traction resulting in an accident and injury. Thoroughly clean any coolant that might have splashed on the tires.

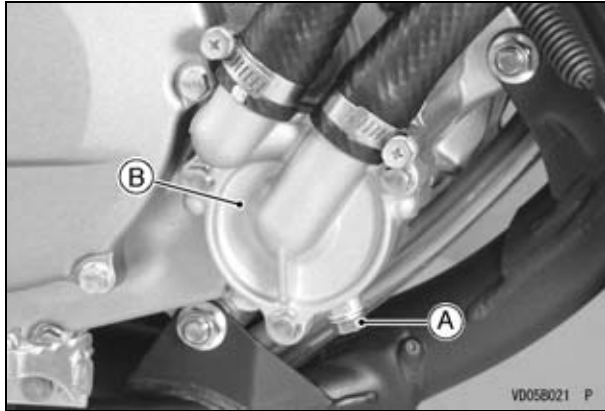

**A. Coolant Drain Bolt (Water Pump) and Gasket  
B. Water Pump Cover**

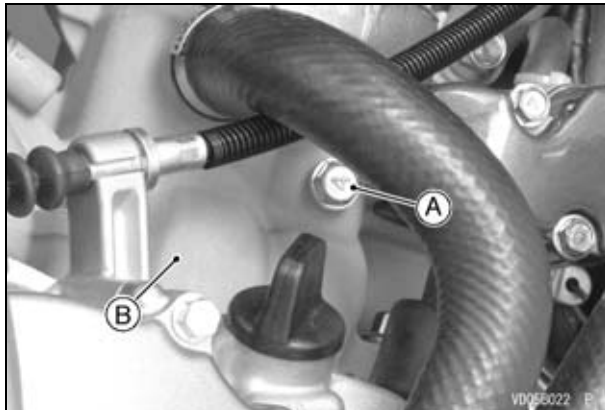

**A. Coolant Drain Bolt (Cylinder) and Gasket  
B. Right Side of the Cylinder**

- Visually inspect the old coolant.
- If whitish cotton-like wafts are observed, aluminum parts in the cooling system are corroded and the system must be flushed.
- If the coolant is brown, iron or steel parts are rusting and the system must be flushed.
- Check the cooling system for damage, loose connections, and leaks.
- Install the coolant drain bolts with their new gaskets at the water pump cover and right side of the cylinder.

**NOTE**

- *Always replace gaskets with new ones.*
- Tighten the coolant drain bolts to the specified torque.

## 46 MAINTENANCE AND ADJUSTMENT

### Tightening Torque

Coolant Drain Bolt (Water Pump):  
5.2 N·m (0.53 kgf·m, 46 in·lb)  
Coolant Drain Bolt (Cylinder):  
8.8 N·m (0.90 kgf·m, 78 in·lb)

- Fill the radiator up to the bottom of the radiator filler neck with coolant.

### NOTE

- *Pour in the coolant slowly so that it can expel the air from the engine and radiator.*
- Bleed the air from the cooling system as follows.
- Loosen the air bleeder bolt on the cylinder head until the coolant begins to flow out the air bleeder bolt hole.

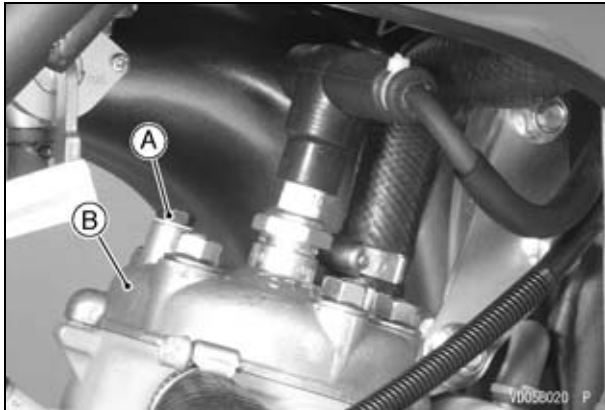

**A. Air Bleeder Bolt and Gasket**  
**B. Cylinder Head**

- Tighten the air bleeder bolt to the specified torque.

### Tightening Torque

Air Bleeder Bolt:  
9.4 N·m (1.0 kgf·m, 83 in·lb)

- If the coolant level is low, add coolant up to the bottom of radiator filler neck.
- Tap the water hoses to force out any air bubbles caught inside.

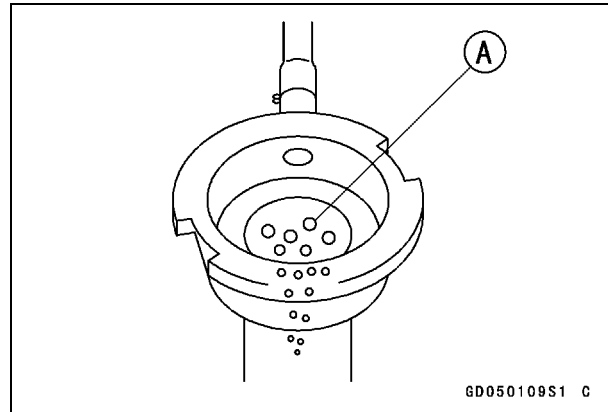

### A. Air Bubbles

- Check the coolant level (see Coolant Level Inspection in this section).
- If the coolant level is low, add coolant up to the bottom of radiator filler neck.
- Install the radiator cap (see Coolant Level Inspection in this section).

- Start the engine and warm up thoroughly, then stop it.
- Check the coolant level after the engine has cooled down.
- If the coolant level is low, add coolant up to the bottom of the radiator filler neck.
- Install the radiator cap.
- Check the cooling system for leaks.

## Spark Plug

The spark plug should be taken out periodically for inspection and regapping. Measure the gap with a wire-type thickness gauge. If incorrect, adjust the gap to the specified value by bending the outer electrode.

### Spark Plug Gap

NGK R6252K-105	0.7 ~ 0.8 mm (0.028 ~ 0.031 in.)
NGK BR9EVX	0.6 ~ 0.7 mm (0.024 ~ 0.028 in.)

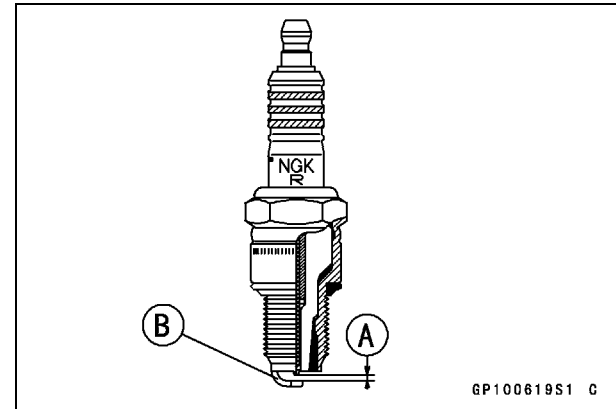

- A. Spark Plug Gap
- B. Outer Electrode



## 48 MAINTENANCE AND ADJUSTMENT

If the plug is oily or has carbon built up on it, clean it. The plug may also be cleaned using a high flash -point solvent and a nonmetal brush (nylon etc.). If the spark plug electrodes are corroded, or damaged, or if the insulator is cracked, replace the plug. The standard spark plug is shown in the table below.

### Standard Spark Plug

NGK R6252K-105
----------------

To find out whether the plug's heat range is correct, remove the plug and examine the ceramic insulator around the center electrode. If the ceramic is light brown, the spark plug correctly matches the engine temperature.

If the ceramic is burned black, the plug should be replaced with a hotter plug.

### Optional Spark Plug

Hotter	NGK BR9EVX
--------	------------

### NOTE

○ If the engine performance drops, try replacing the spark plug to regain performance.

### Spark Plug Removal and Installation

- Clean the cylinder head around the spark plug cap hole before removing the spark plug.
- Pull the spark plug cap off the spark plug.
- Apply the spark plug wrench to the spark plug.
- Loosen and remove the spark plug.

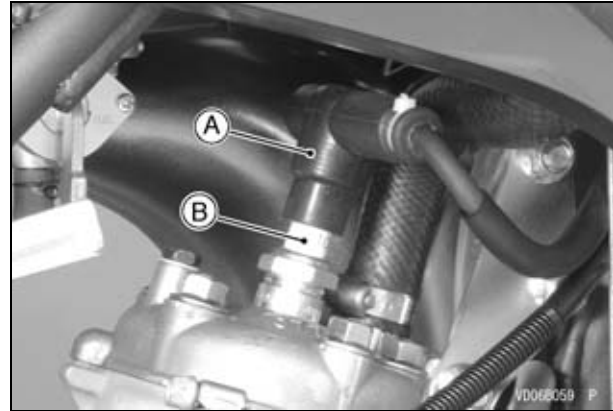

**A. Spark Plug Cap**  
**B. Spark Plug**

- When reinstalling the spark plug, tighten it to the specified torque.

### Tightening Torque

Spark Plug: 25.5 N·m (2.60 kgf·m, 18.8 ft·lb)
--

- Install the spark plug cap.
- Pull up the spark plug cap lightly to make sure of the installation of the spark plug cap.

### NOTE

○ If the engine performance drops, try replacing the spark plug to regain performance.

## Ignition Timing

Since this motorcycle is equipped with a capacitor discharge ignition (CDI) system, the ignition timing should never require adjustment unless the stator was incorrectly installed during engine reassembly. If there is any doubt as to the timing, inspect and, if necessary, adjust it as follows.

- Free the carburetor overflow hose from the clamp on the magneto cover.
- Remove the magneto cover bolts and take off the magneto cover and the gasket.

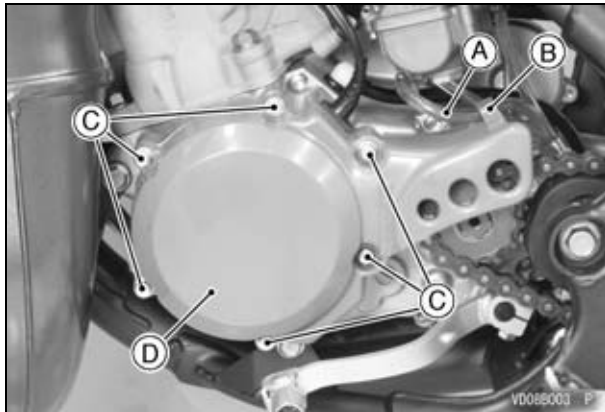

- A. Carburetor Overflow Hose**
- B. Clamp**
- C. Magneto Cover Bolts**
- D. Magneto Cover and Gasket**

- Check to see if the middle mark of the three-marks on the stator coil plate is aligned with the straight surface of the projection on the crankcase.

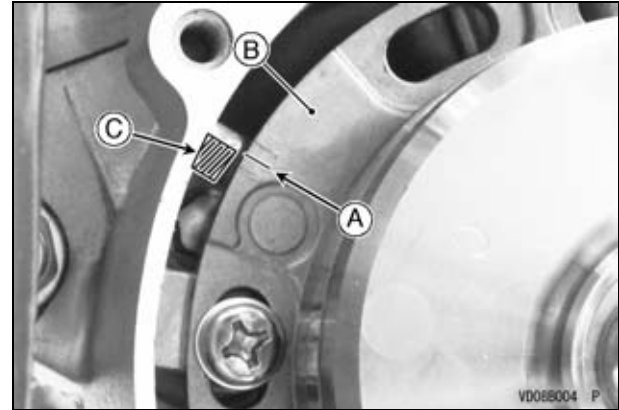

- A. Middle Mark**
- B. Stator Coil Plate**
- C. Straight Surface**

- If the marks are not aligned, loosen the stator coil plate mounting screws and turn the stator coil plate.

## 50 MAINTENANCE AND ADJUSTMENT

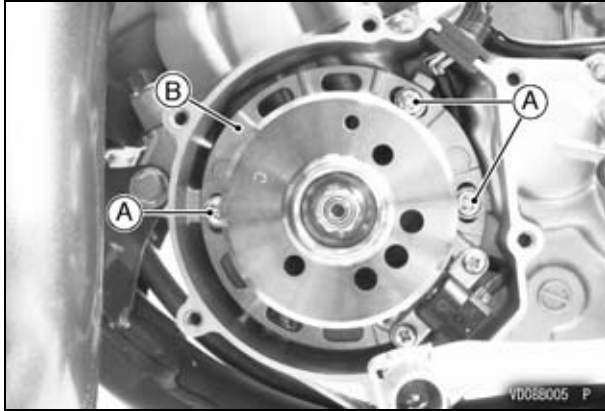

- A. Stator Coil Plate Mounting Screws
- B. Stator Coil Plate

- Tighten the stator coil plate mounting screws to the specified torque.

### Tightening Torque

Stator Coil Plate Mounting Screws:  
5.2 N·m (0.53 kgf·m, 46 in·lb)

- Replace the magneto cover gasket with a new one.
- Install the magneto cover.
- Hold the carburetor overflow hose to the clamp on the magneto cover.

### NOTE

- The ignition timing can be adjusted to change the power band to suit the rider's preference or ability.
- If necessary, adjust the timing by shifting the stator coil plate position within the three lines.



- A. Three Lines

### NOTE

- For best engine performance, it is very important to adjust the ignition timing within the adjustable range just explained.

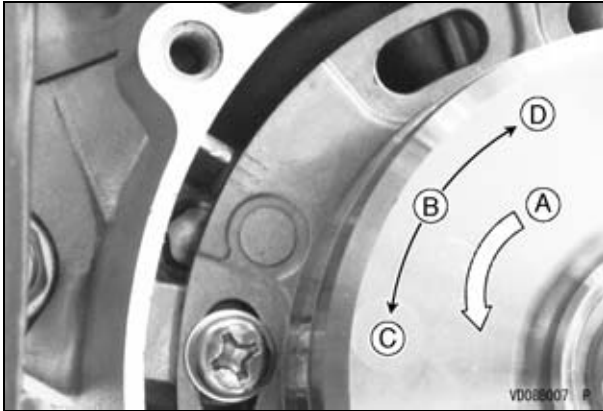

- A. Crankshaft Rotation**
- B. Stator Rotation**
- C. Retard**
- D. Advance**

- Tighten the stator coil plate mounting screws to the specified torque.

### **Tightening Torque**

Stator Coil Plate Mounting Screws: 5.2 N·m (0.53 kgf·m, 46 in·lb)
--

- Replace the magneto cover gasket with a new one.
- Install the magneto cover.
- Hold the carburetor overflow hose to the clamp on the magneto cover.

- Test ride the motorcycle and readjust the ignition timing if necessary.

## 52 MAINTENANCE AND ADJUSTMENT

### Air Cleaner

A clogged air cleaner restricts the air intake, increases fuel consumption, reduces engine power, and can cause spark plug fouling. Inspect the air intake system, which includes the air cleaner element and air duct to the carburetor, and the duct clamps and carburetor, before each race or practice session.

#### **⚠ WARNING**

If dirt or dust is allowed to pass through into the carburetor, the throttle may become stuck, possibly causing accident. Be sure to keep the dust from entering during cleaning.

#### **NOTICE**

A clogged air cleaner will affect fuel mixture to the engine and reduce engine power and cause spark plug fouling.

#### **NOTE**

○ In dusty areas, the element should be cleaned more frequently than recommended interval.

○ After riding through rain or on muddy roads, the element should be cleaned immediately.

#### **Element Removal and Inspection**

- Remove the seat bolts.
- Remove the seat rearward.

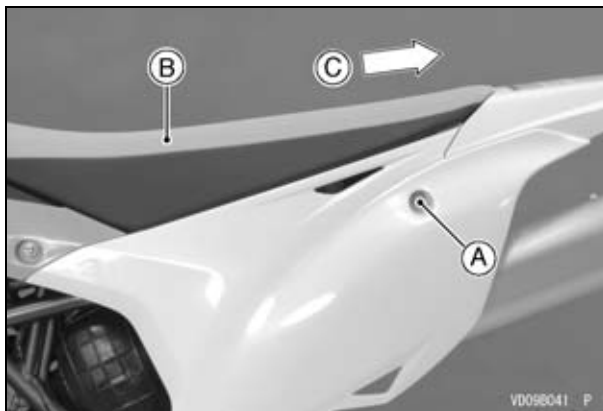

A. Seat Bolt (Both Sides)

B. Seat

C. Rearward

- Remove the wing bolt, and take out the air cleaner element.

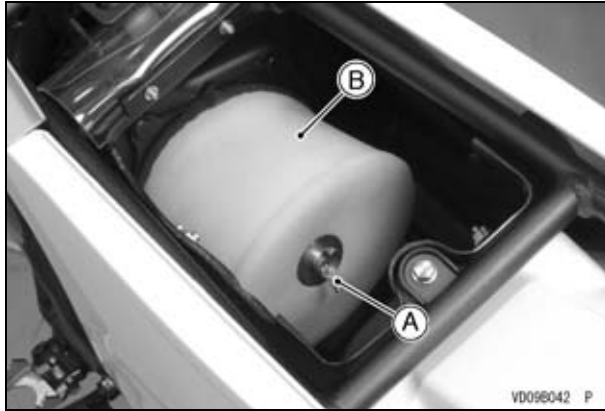

**A. Wing Bolt**  
**B. Air Cleaner Element**

- Check inside of the intake tract and carburetor for dirt. If dirty, clean the intake tract and carburetor thoroughly.
- Stuff a clean, lint-free towel into the carburetor to keep dirt from entering the carburetor.
- Wipe out the inside of the air cleaner housing with a clean, damp towel.
- Take the air cleaner element off its frame.

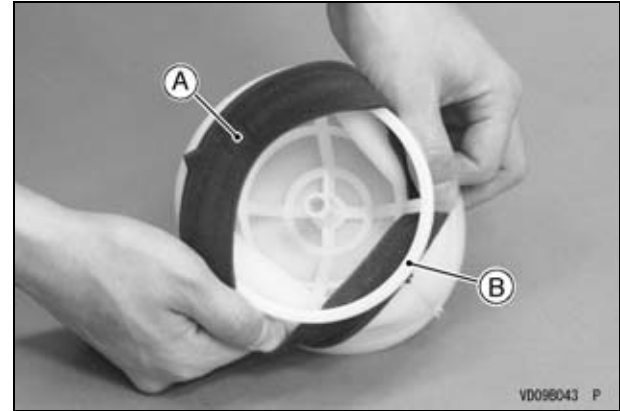

**A. Air Cleaner Element**  
**B. Element Frame**

### ***NOTICE***

**Do not twist or wring the element, as it gets easily torn or damaged.**

- Inspect the air cleaner element. If it is dirty, clean it. Also check if the element is in good condition (no tears, hardening or shrinkage). If damaged, replace the element or it will allow dirt into the carburetor.

## 54 MAINTENANCE AND ADJUSTMENT

### **WARNING**

A clogged air cleaner may allow dirt and dust to enter the carburetor and the throttle may stick resulting in a hazardous operating condition. Clean the air cleaner according to the periodic maintenance chart; more often if the motorcycle is used in extremely dusty conditions.

### **NOTICE**

A clogged air cleaner may allow dirt and dust to enter the engine, causing it to wear excessively or to become damaged.

#### *Element Cleaning and Installation*

- Clean the air cleaner element in a bath of a high flash-point solvent or hot soapy water. Rinse the element with clear water to remove all traces of the cleaning solution.

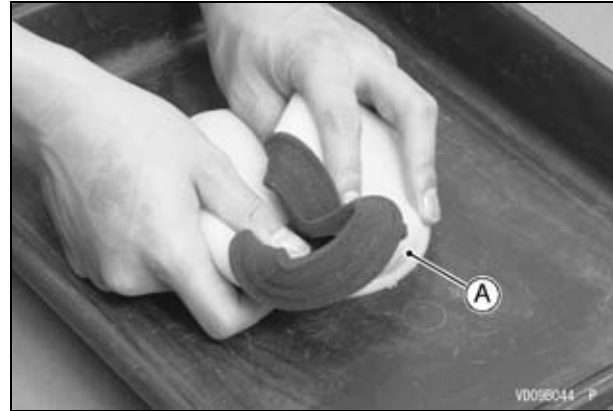

**A. Air Cleaner Element**

- Squeeze the air cleaner element dry in a clean towel.

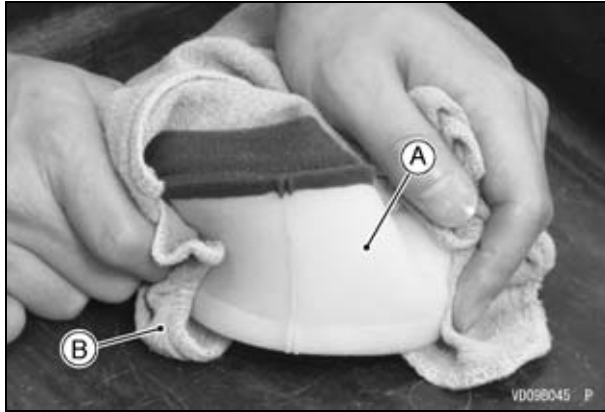

**A. Air Cleaner Element**  
**B. Clean Towel**

**NOTICE**

**Do not twist, wring or blow the element dry to avoid damaging it.**

**⚠ WARNING**

**Gasoline and low flash-point solvents can be flammable and/or explosive and cause severe burns. Clean the element in a well-ventilated area, and take care that there is no spark or flame anywhere near the working areas. Do not use gasoline or low flash-point solvents to clean the element.**

- After cleaning, let the element dry completely. Saturate the element with a high-quality foam air filter oil and make sure that the oil is evenly applied throughout the element. Squeeze out the excess oil, but do not wring the element as this could cause tearing. In this case, too much oil is better than too little. Finally pat the inside of the element with a paper towel to remove any excess oil.
- Before installation, check the element for damage such as tears, hardening, or shrinkage. If damaged, replace the element.
- Apply grease to the air cleaner element lip.

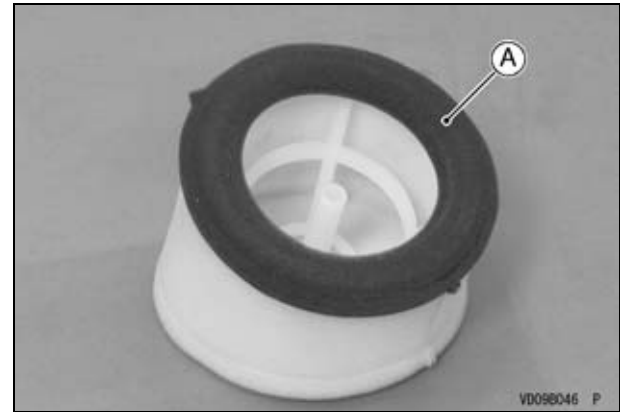

**A. Apply grease.**

- Remove the towel from the carburetor.
- Install the element onto its frame.



## 56 MAINTENANCE AND ADJUSTMENT

- Install the air cleaner element so that the projection on it fits into the notch in the holder.

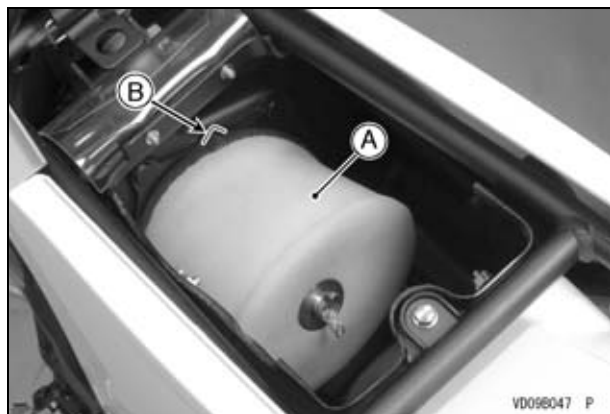

**A. Air Cleaner Element**  
**B. Projection and Notch**

- Tighten the wing bolt.

- Insert the hooks of the seat under the flange collar and bracket.

### NOTE

- *Take care not to damage the side covers with the bracket of seat.*

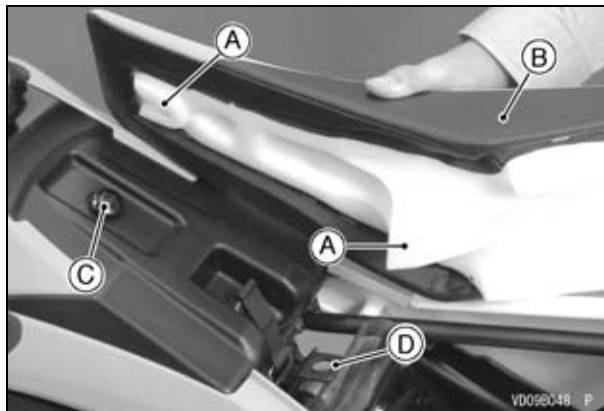

**A. Hooks**  
**B. Seat**  
**C. Flange Collar**  
**D. Bracket**

- Install the seat bolts.
- Pull up the rear end of the seat to make sure it is securely installed.

## Throttle Cable

### Throttle Cable Adjustment

Inspect the throttle grip for smooth operation in all steering positions. Check and adjust the throttle cable in accordance with the Periodic Maintenance Chart.

- Check that the throttle grip has 2 ~ 3 mm (0.08 ~ 0.12 in.) of play and turns smoothly.

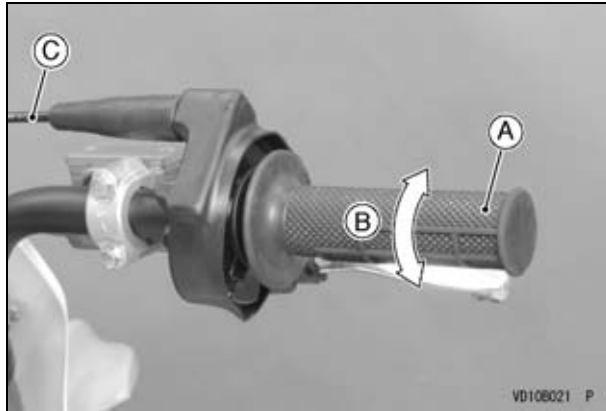

- A. Throttle Grip**
- B. 2 ~ 3 mm (0.08 ~ 0.12 in.)**
- C. Throttle Cable**

- If the play is incorrect, pull the rubber boot off the upper end of the throttle cable.

- Loosen the locknut on the upper end of the throttle cable and turn the adjuster to obtain the specified play. Then, tighten the locknut and reinstall the rubber boot.

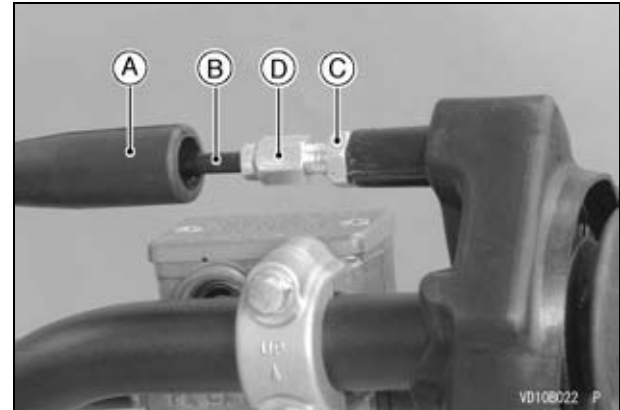

- A. Rubber Boot**
- B. Throttle Cable**
- C. Locknut**
- D. Adjuster**

- If the free play cannot be set with the adjuster on the upper end of the throttle cable, pull the rubber boot off top of the carburetor and make the necessary free play adjustment with the adjuster on the lower end of the cable. Then, tighten the locknut and reinstall the rubber boot.

## 58 MAINTENANCE AND ADJUSTMENT

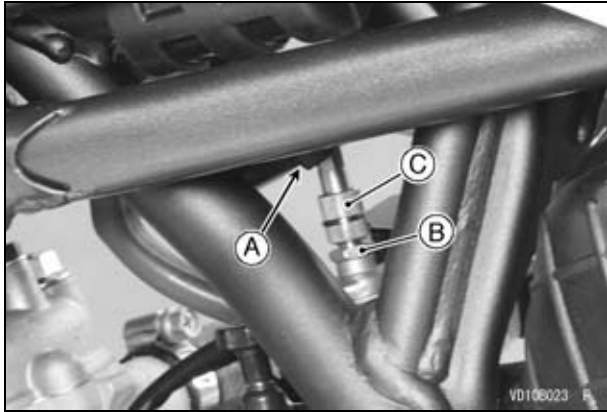

- A. Rubber Boot**
- B. Locknut**
- C. Adjuster**

- With the engine idling, turn the handlebars both ways and check if handlebars movement changes the idle speed. If so, the throttle cable may be improperly adjusted or incorrectly routed, or damaged. Be sure to correct any of these conditions before riding.

### **WARNING**

Operation with improperly adjusted, incorrectly routed, or damaged cable could result in an unsafe riding condition. Be sure the control cable is adjusted and routed correctly, and is free from damage.

## Carburetor

### *Idle Speed Adjustment*

Idle speed adjustment is carried out using the air screw and idle adjusting screw.

- Start the engine and warm it up thoroughly.
- First turn the air screw in until it is lightly seated, then back it out 1 1/2 turns (KX85C).
- First turn the air screw in until it is lightly seated, then back it out 1 7/8 turns (KX100F).

### **NOTICE**

**Do not force the air screw beyond the fully seated position, or the adjusting mechanism may be damaged.**

- Turn the idle adjusting screw to obtain the desired idle speed. If you do not wish the engine to idle, turn out the screw until the engine stops.

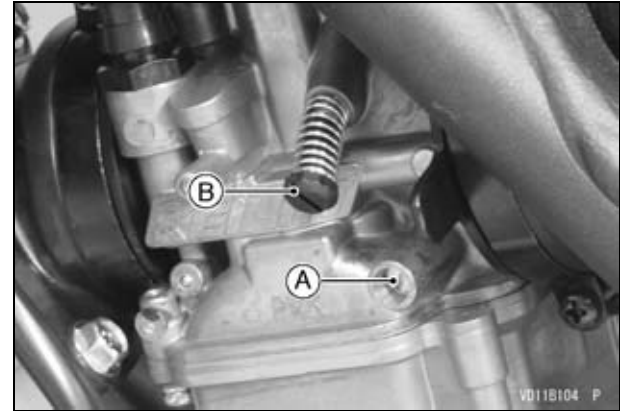

**A. Air Screw**  
**B. Idle Adjusting Screw**

- Open and close the throttle a few times to make sure the idle speed does not change, and readjust if necessary.
- With the engine idling, turn the handlebars both ways and check if handlebars movement changes the idle speed. If so, the throttle cable may be improperly adjusted, incorrectly routed, or damaged. Be sure to correct any of these conditions before riding.

### **⚠ WARNING**

**Operation with damaged cables could result in an unsafe riding condition. Replace damaged control cables before operation.**

## 60 MAINTENANCE AND ADJUSTMENT

### NOTICE

This motorcycle's radiator does not incorporate cooling fan. Prolonged idling of the engine with no airflow through the radiator can cause coolant loss and engine overheating resulting in possible engine damage. Any riding conditions that increase engine temperature will further reduce idling time before coolant loss occurs. These conditions include high ambient temperature, sandy or muddy terrain, or other conditions causing high engine loads at low speeds. Furthermore, warming the engine up excessively before operation, or leaving idling with the hot engine temperature after operation results in the engine overheating, too.

### *Cleaning the Carburetor*

- Pull the rubber boot off the upper end of the throttle cable (see Throttle Cable section).

- Slide out the cable housing dust cover.
- Remove the screws and the throttle case cover.

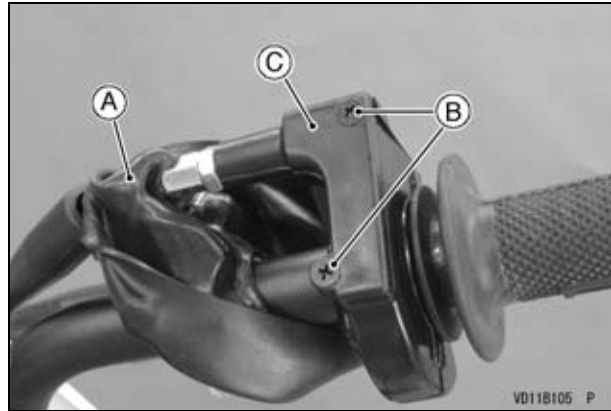

- A. Cable Housing Dust Cover
- B. Screws
- C. Throttle Case Cover

## MAINTENANCE AND ADJUSTMENT 61

- Loosen the locknut.
- Remove the upper end of the throttle cable.
- Take the adjuster and locknut off the throttle case.

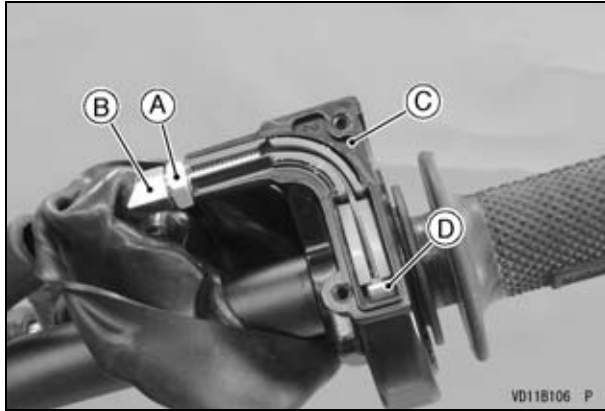

- A. Locknut**
- B. Adjuster**
- C. Throttle Case**
- D. Upper End of the Throttle Cable**

- Turn the fuel tap lever to the “OFF” position (see Stopping the Engine section).
- Free the carburetor overflow hose from the clamp on the magneto cover.
- Slide out the clamp and pull the fuel hose off.
- Loosen the clamp screws.
- Remove the carburetor from the end of the air cleaner duct, and then pull it out of the cylinder intake joint.

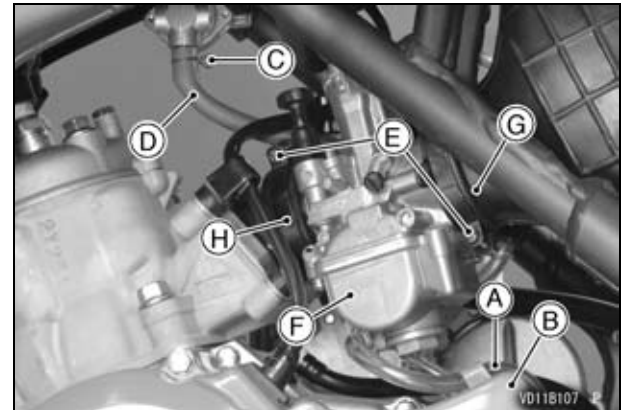

- A. Carburetor Overflow Hose**
- B. Magneto Cover**
- C. Clamp**
- D. Fuel Hose**
- E. Clamp Screws**
- F. Carburetor**
- G. Air Cleaner Duct**
- H. Cylinder Intake Joint**

## 62 MAINTENANCE AND ADJUSTMENT

- Place a container under the fuel drain plug.
- Remove the fuel drain plug and drain the fuel.

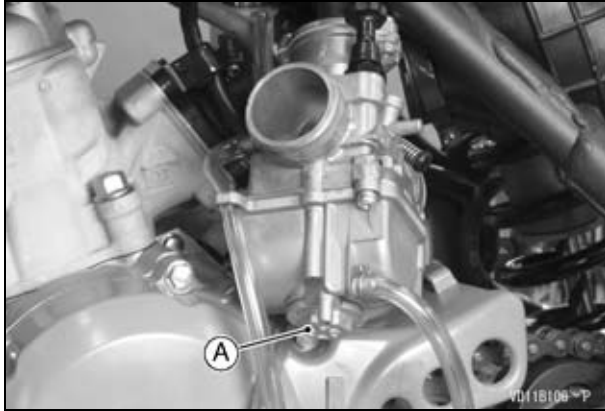

A. Fuel Drain Plug

### ***NOTICE***

**Never drop the carburetor, especially on a hard surface.  
Such a shock to the carburetor can damage it.**

- Remove the screws and take off the carburetor body.

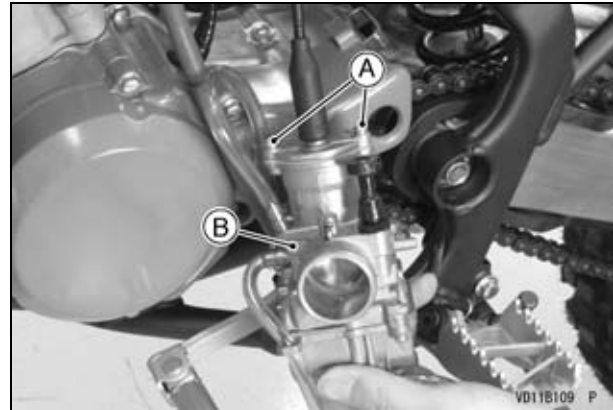

A. Screws

B. Carburetor Body

- After removing the carburetor, cover the cylinder intake joint and air cleaner duct with a clean cloth to protect them from dirt.
- Clean the carburetor as follows.

**⚠ WARNING**

Gasoline and low flash-point solvents can be flammable and/or explosive and cause severe burns. Clean the carburetor in a well-ventilated area, and take care that there are no sparks or flame anywhere near the working area; this includes any appliance with a pilot light. Do not use gasoline or a low flash-point solvent to clean the carburetor.

**NOTICE**

Do not use compressed air on an assembled carburetor, the float may be deformed by the pressure. Remove as many rubber or plastic parts from the carburetor as possible before cleaning the carburetor with a cleaning solution. This will prevent damage or deterioration of the parts. Do not use a strong carburetor cleaning solution which could attack the plastic parts; instead, use a mild high flash-point cleaning solution safe for plastic parts. Do not use wire or any other hard instrument to clean carburetor parts, especially jets, as they may be damaged.

- Immerse all metal parts in a carburetor cleaning solution.

- Rinse the parts in water.
- After the parts are cleaned, dry them with compressed air.
- Blow through the air and fuel passages with compressed air.

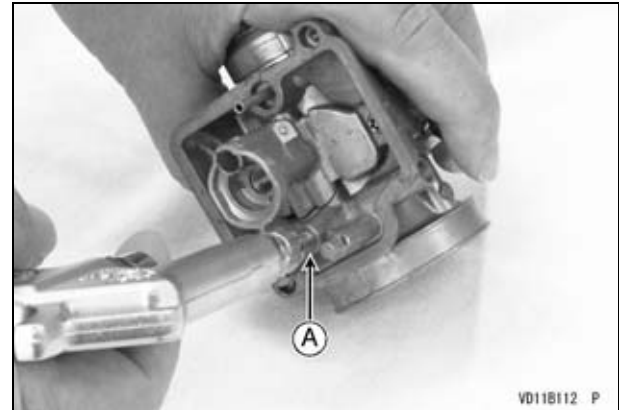

A. Compressed Air

**NOTICE**

If dirt gets through into the engine, excessive engine wear and possibly engine damage will occur.

- Lubricate the lower and upper end of the throttle cable (see Lubrication section) and reinstall it.





**A. Lower End of the Throttle Cable**

- Install the removed parts.

### **⚠ WARNING**

Operation with improperly adjusted, incorrectly routed, or damaged cable could result in an unsafe riding condition. Be sure the control cable is adjusted and routed correctly, and is free from damage.

- Adjust the throttle cable (see Throttle Cable section).

## Clutch

### *Clutch Lever Adjustment*

Proper clutch lever free play is 8 ~ 13 mm (0.3 ~ 0.5 in.). Lever play increases with cable stretch and friction plate wear, requiring periodic adjustment.

When the clutch lever free play is out of specification, first try adjusting it at the clutch lever as follows.

- Slide the dust cover of the clutch lever.
- Loosen the locknut, turn the adjuster to obtain the proper amount of clutch lever play, then tighten the locknut.

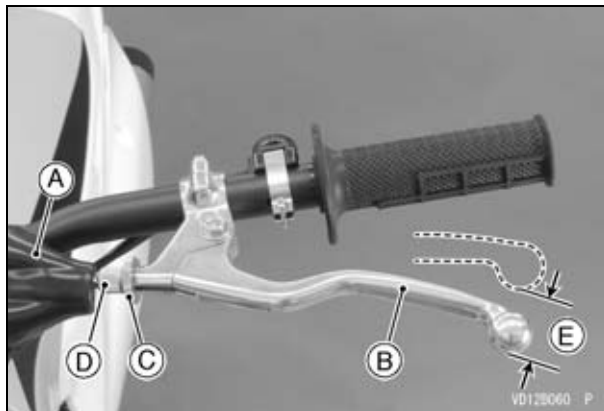

- A. Dust Cover**
- B. Clutch Lever**
- C. Locknut**
- D. Adjuster**
- E. 8 ~ 13 mm (0.3 ~ 0.5 in.)**

If the clutch lever free play cannot be adjusted at the clutch lever, make the adjustment further down the cable as follows.

- Loosen the locknut at the clutch lever.
- Turn the adjuster in all the way, then tighten the locknut.
- Loosen the locknut in the middle of the clutch cable, and turn the adjusting nut so that the clutch lever play is 8 ~ 13 mm (0.3 ~ 0.5 in.).

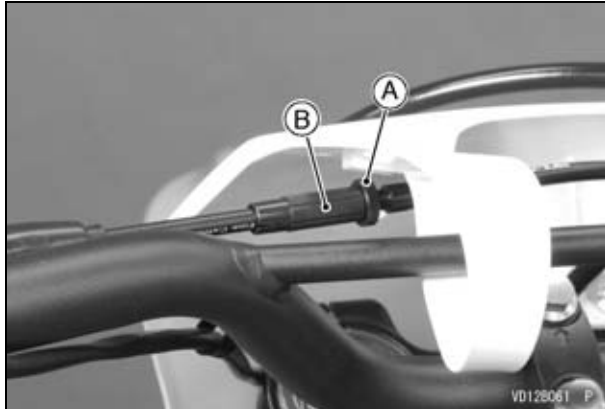

**A. Locknut**  
**B. Adjusting Nut**

- Tighten the locknut.
- Start the engine, check that the clutch does not slip and it releases properly.

- Slide the dust cover back into place.

**⚠ WARNING**

**Excess clutch cable play could prevent clutch disengagement and cause a crash resulting in serious injury or death. When adjusting the clutch cable, be sure the upper end of the outer cable is fully seated in its fitting so that it doesn't slip into place later and create excessive cable play.**

**NOTE**

- *After the adjustment is made, start the engine and check that the clutch does not slip and that it releases properly.*

**Friction and Steel Plates Removal**

- Drain the transmission oil (see Transmission Oil section).
- Give plenty of play to the clutch cable by turning the adjuster.
- Line up the slots in the clutch lever, locknut, and adjuster, and then free the cable from the clutch lever.

## 66 MAINTENANCE AND ADJUSTMENT

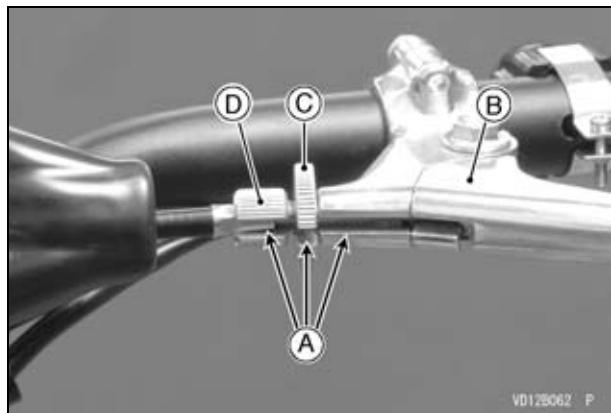

- A. Slots
- B. Clutch Lever
- C. Locknut
- D. Adjuster

- Take the clutch cable off the cable holder.
- Take the lower end of the clutch cable off the clutch release lever.
- Remove the clutch cover bolts.
- Turn the clutch release lever toward the rear.

### ***NOTICE***

**Do not remove the clutch release shaft unless it is absolutely necessary. If the clutch release shaft is removed, the oil seal must be replaced with a new one.**

- Remove the clutch cover and the gasket.

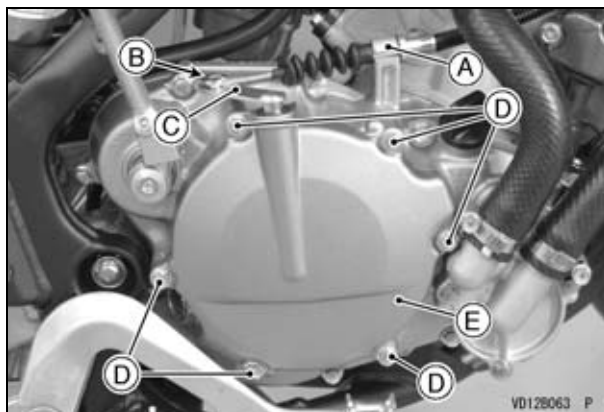

- A. Cable Holder
- B. Lower End of the Clutch Cable
- C. Clutch Release Lever
- D. Clutch Cover Bolts
- E. Clutch Cover and Gasket

- Remove the clutch spring bolts, springs and clutch pressure plate.

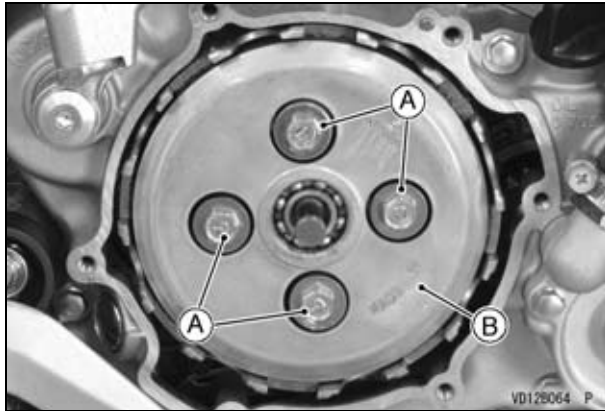

**A. Clutch Spring Bolts and Springs**  
**B. Clutch Pressure Plate**

- Remove the friction plates and steel plates.

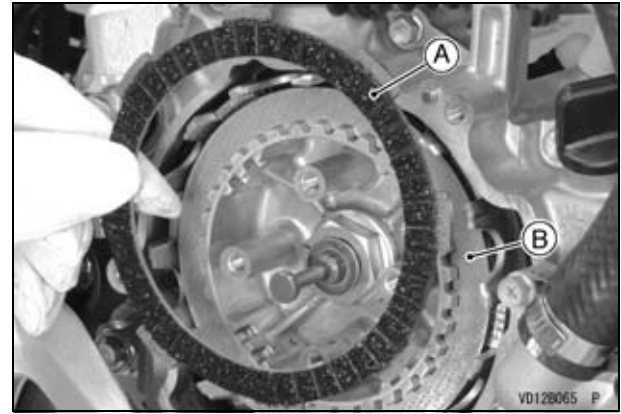

**A. Friction Plates**  
**B. Steel Plates**

When it is hard to remove the clutch spring bolts, use a flywheel & pulley holder (special tool: 57001-1605) on the magneto flywheel as follows.

- Remove the magneto cover (see Ignition Timing section).
- Holding the flywheel with the flywheel & pulley holder (special tool: 57001-1605).

## 68 MAINTENANCE AND ADJUSTMENT

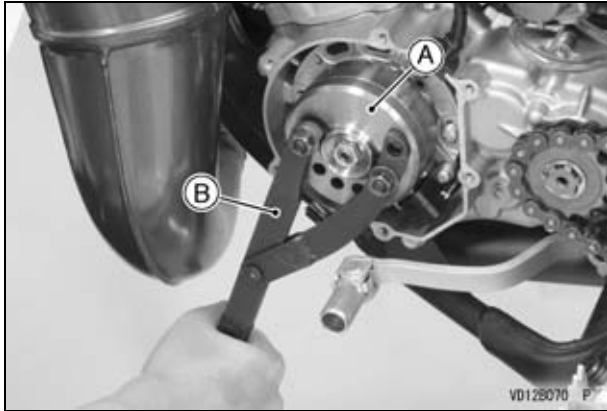

- A. Flywheel**
- B. Flywheel & Pulley Holder (Special Tool: 57001-1605)**

### *Friction and Steel Plates Wear/Damage Inspection*

- Visually inspect the friction and steel plates to see if they show any signs of seizure, or uneven wear.
- If any plates show signs of damage, replace all friction plates and steel plates as a set.
- Measure the thickness of the friction plates with vernier calipers.
- If they have worn past the service limit, replace them with new ones.

### **Friction Plate Thickness**

Standard	2.92 ~ 3.08 mm (0.115 ~ 0.121 in.)
Service Limit	2.8 mm (0.11 in.)

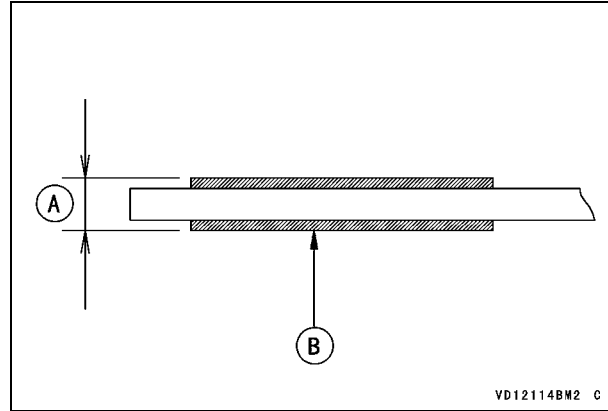

- A. Thickness**
- B. Friction Plate**

### *Friction and Steel Plate Warp Inspection*

- Place each friction plate and steel plate on a surface plate, and measure the amount of friction plate and steel plate warp with a thickness gauge (i.e., the gap between the surface plate and each friction plate or steel plate).
- If any plate is warped over the service limit, replace it with a new one.

### **Friction and Steel Plate Warp**

Friction Plate	Standard	0.15 mm (0.0059 in.) or less
	Service Limit	0.3 mm (0.01 in.)

Steel Plate	Standard	0.15 mm (0.0059 in.) or less
	Service Limit	0.3 mm (0.01 in.)

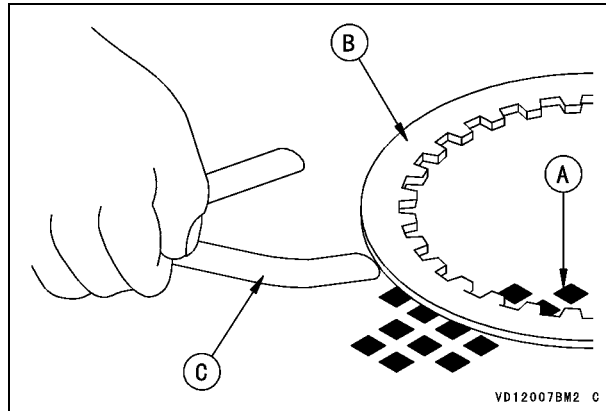

- A. Surface Plate
- B. Friction or Steel Plate
- C. Thickness Gauge

#### *Friction and Steel Plate Installation*

- Install all parts in the reverse order of removal.
- Install the friction plates and steel plates, starting with a friction plate and alternating them. Finish with a friction plate.

### **NOTICE**

If dry steel plates and friction plates are installed, apply transmission oil to the surfaces of each plate to avoid clutch plate seizure.

- Apply molybdenum disulfide grease to the swollen areas of the clutch spring push rod.
- Install the clutch spring push rod and the washer.

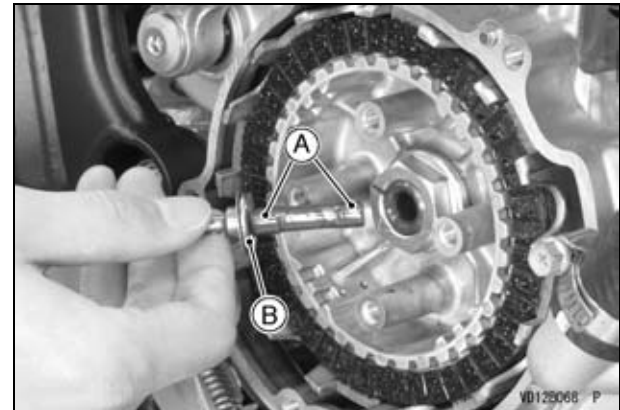

- A. Apply molybdenum disulfide grease.
- B. Clutch Spring Push Rod and Washer

- Install the clutch pressure plate and springs.
- Holding the flywheel with the flywheel & pulley holder (special tool: 57001-1605).

## 70 MAINTENANCE AND ADJUSTMENT

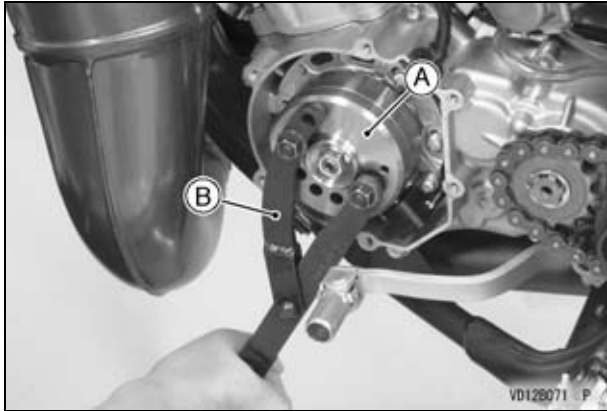

**A. Flywheel**

**B. Flywheel & Pulley Holder (Special Tool:  
57001-1605)**

- Tighten the clutch spring bolts to the specified torque.

### **Tightening Torque**

Clutch Spring Bolts:  
9.3 N·m (0.95 kgf·m, 82 in·lb)

- Replace the clutch cover gasket with a new one.
- Turn the clutch release lever toward the rear so that the push rod fit into the release lever shaft.
- Install the clutch cover to the crankcase, making sure that the two dowel pins are installed between mating surfaces.

- Tighten the clutch cover bolts to the specified torque.

### **Tightening Torque**

Clutch Cover Bolts:  
9.4 N·m (1.0 kgf·m, 83 in·lb)

- Replace the magneto cover gasket with a new one.
- Install the magneto cover.
- Check the transmission oil level (see Transmission Oil section).
- Adjust the clutch cable (see Clutch section).

---

### Piston

---

#### *Piston Removal*

- Turn the fuel tap lever to the “OFF” position (see Stopping the Engine section).
- Drain the coolant (see Cooling System section).
- Remove the fuel tank mounting bolt for easier removal of cylinder.



**A. Fuel Tank Mounting Bolt**

- Remove the bolts and the shrouds on both sides.

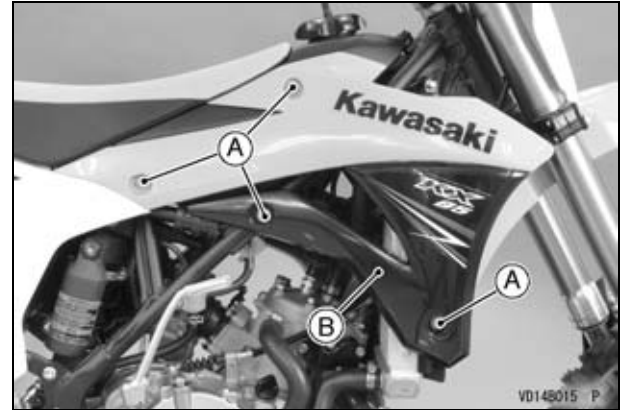

**A. Bolts (Both Sides)  
B. Shrouds (Both Sides)**



## 72 MAINTENANCE AND ADJUSTMENT

- Remove the radiator screen bolt.
- Clear the hook and remove the radiator screen.

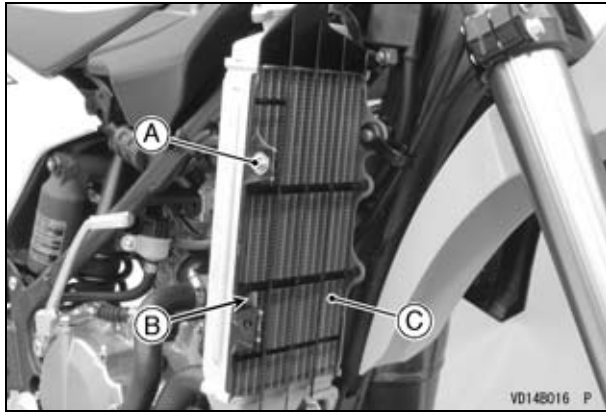

- A. Radiator Screen Bolt
- B. Hook
- C. Radiator Screen

- Disconnect the overflow hose.
- Loosen the water hose clamp screws, and disconnect the water hoses.

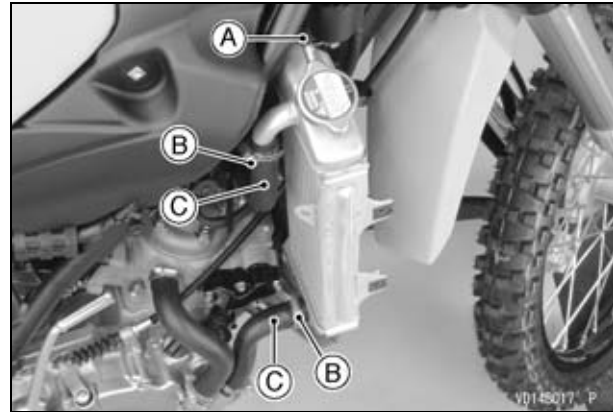

- A. Overflow Hose
- B. Water Hose Clamp Screws
- C. Water Hoses

- Remove the radiator mounting bolts, clamp and radiator.

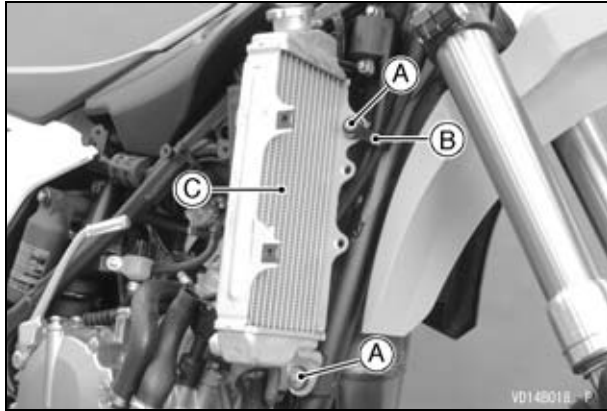

- A. Radiator Mounting Bolts
- B. Clamp
- C. Radiator

- Loosen the water hose clamp screws, and disconnect the water hoses.

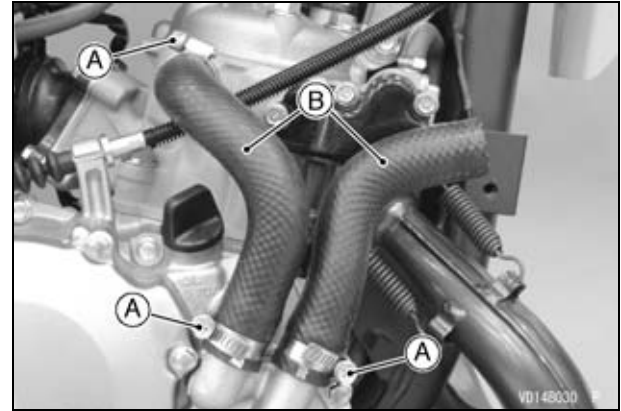

- A. Water Hose Clamp Screws
- B. Water Hoses

## 74 MAINTENANCE AND ADJUSTMENT

- Remove the spark plug cap (see Spark Plug section).
- Remove the muffler (see Exhaust System section).
- Remove the expansion chamber mounting springs.

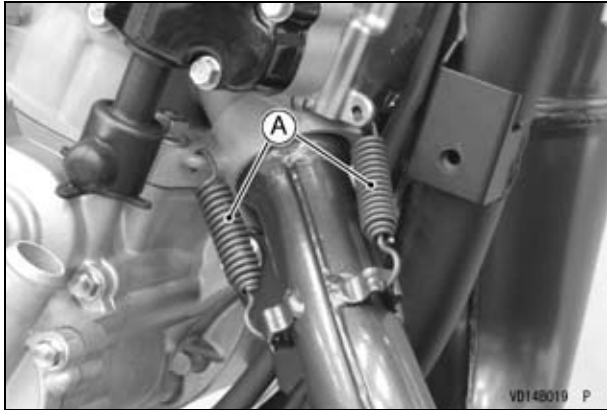

**A. Expansion Chamber Mounting Springs**

- Remove the shroud screen bolt and shroud screen.

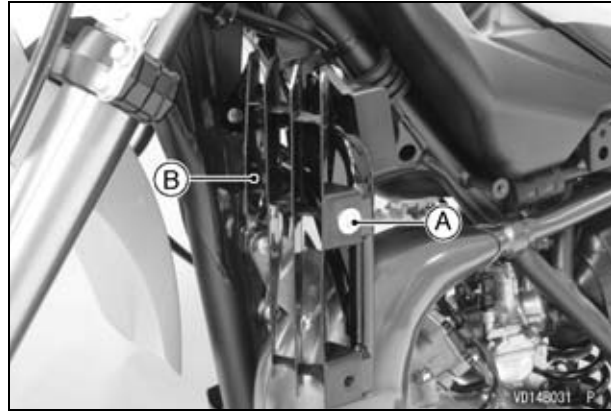

**A. Shroud Screen Bolt  
B. Shroud Screen**

## MAINTENANCE AND ADJUSTMENT 75

- Remove the expansion chamber mounting bolt and take off the expansion chamber.

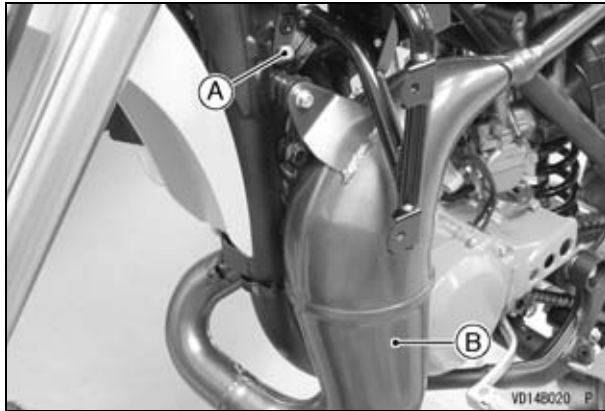

- A. Expansion Chamber Mounting Bolt**
- B. Expansion Chamber**

- Remove the engine bracket mounting bolts, nuts and the engine brackets.
- Remove the cylinder head nuts, cylinder head and the gasket.

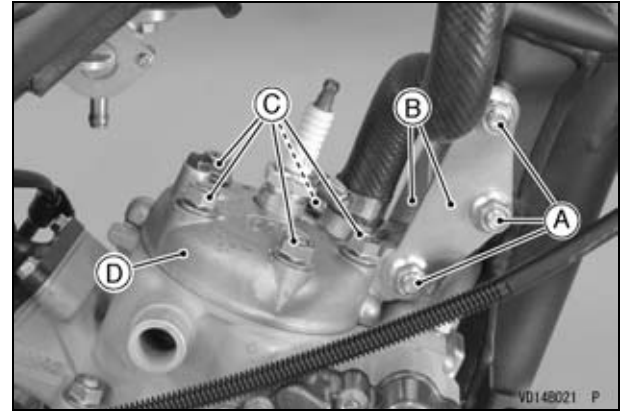

- A. Engine Bracket Mounting Bolts and Nuts**
- B. Engine Brackets**
- C. Cylinder Head Nuts**
- D. Cylinder Head and Gasket**

## 76 MAINTENANCE AND ADJUSTMENT

- Remove the carburetor from the cylinder intake joint (see Carburetor section).
- Remove the KIPS cover bolts and the KIPS cover.
- Remove the KIPS cover gasket.

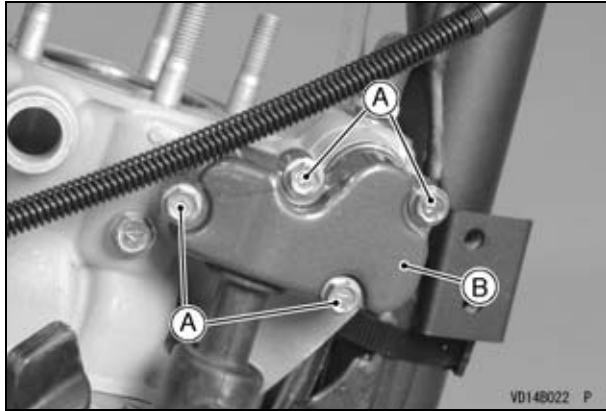

- A. KIPS Cover Bolts**
- B. KIPS Cover and Gasket**

- Remove the circlip.
- Push the shaft lever, and disconnect the link lever to the operating rod.
- Push the boot down.

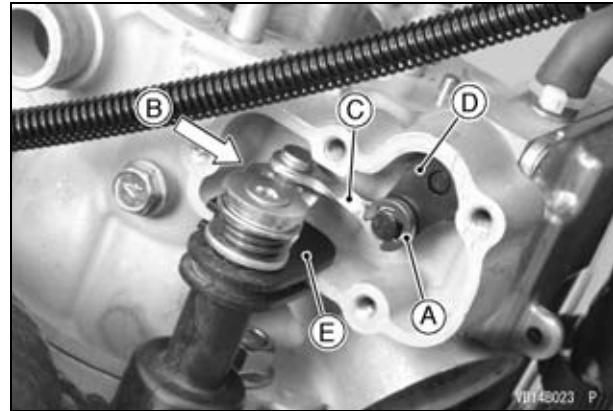

- A. Circlip**
- B. Push the Shaft Lever**
- C. Link Lever**
- D. Operating Rod**
- E. Boot**

## MAINTENANCE AND ADJUSTMENT 77

- Open the alternator lead from the clamp.
- Remove the cylinder nuts.
- Lift off the cylinder, and remove the cylinder base gasket. If necessary, tap lightly around the base of the cylinder with a plastic mallet, taking care not to damage the cylinder.

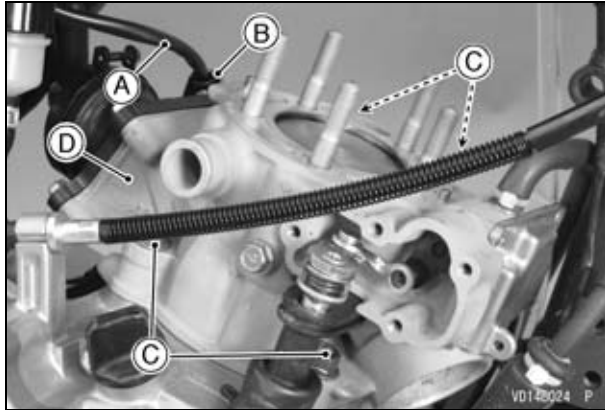

- A. Alternator Lead**
- B. Clamp**
- C. Cylinder Nuts**
- D. Cylinder and Cylinder Base Gasket**

- Stuff a clean cloth into the crankcase opening around the connecting rod so that no parts will fall into the crankcase.
- Remove one of the piston pin snap rings with needle nose pliers.

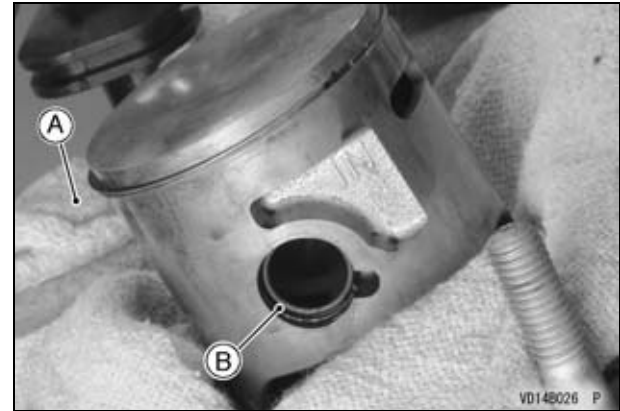

- A. Clean Cloth**
- B. Piston Pin Snap Ring**

## 78 MAINTENANCE AND ADJUSTMENT

- Remove the piston by pushing the piston pin out the side from which the snap ring was removed. Use a piston pin puller assembly (special tool: 57001-910), if the pin is tight.

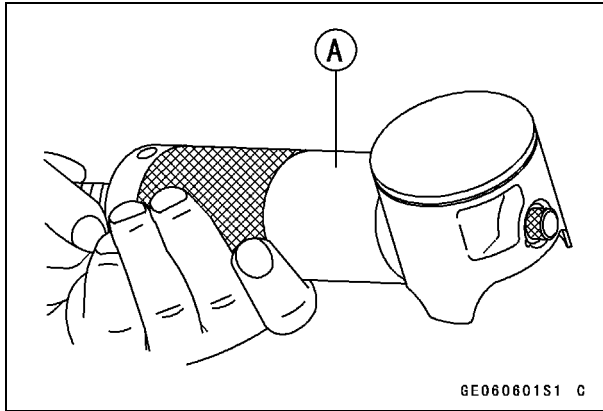

**A. Piston Pin Puller Assembly (Special Tool: 57001-910)**

### *Piston Ring Removal*

- Carefully spread the ring opening with your thumbs and then push up on the opposite side of the ring to remove it.

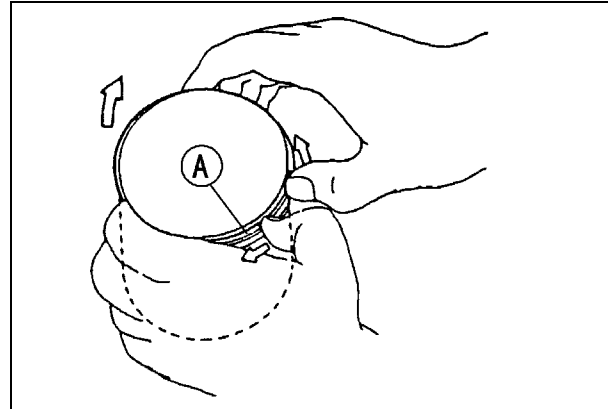

**A. Piston Ring**

### *Piston Ring/Ring Groove Clearance Inspection*

- Visually inspect the piston ring and the piston ring groove.
- If the ring is worn unevenly or damaged, it must be replaced.
- If the piston ring groove is worn unevenly or damaged, the piston must be replaced and fitted with a new ring.
- Check for uneven the piston ring groove wear by inspecting the ring seating.
- The ring should fit perfectly parallel to the groove surface. If not, replace the piston and the piston ring.
- With the piston ring in its groove, make several measurements with a thickness gauge to determine piston ring/ring groove clearance.

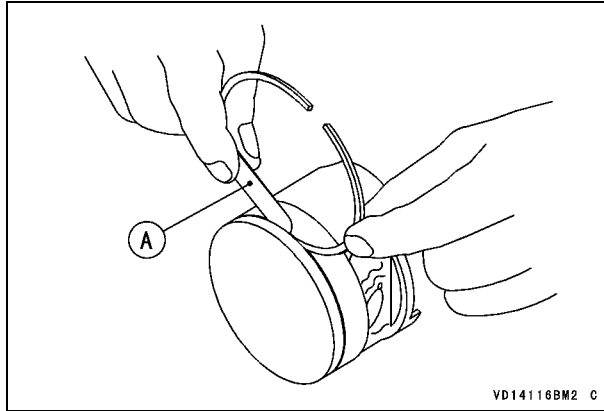

**A. Thickness Gauge**

### Piston Ring/Ring Groove Clearance

Standard	KX85C	0.02 ~ 0.06 mm (0.0008 ~ 0.0024 in.)
	KX100F	0.04 ~ 0.08 mm (0.0016 ~ 0.0031 in.)
Service Limit	KX85C	0.16 mm (0.0063 in.)
	KX100F	0.18 mm (0.0071 in.)

- If the piston ring/ring groove clearance is greater than the service limit, measure the ring thickness

and groove width as follows to decide whether to replace the ring, the piston or both.

- If the piston ring has worn down to less than the service limit, replace the ring; if the piston ring groove width exceeds the service limit, replace the piston.

### Piston Ring Thickness Inspection

- Measure the thickness at several points around the ring with a micrometer.

### Piston Ring Thickness

Standard	0.97 ~ 0.99 mm (0.038 ~ 0.039 in.)
Service Limit	0.90 mm (0.035 in.)

- If any of the measurements is less than the service limit, replace the ring.

### NOTE

- *When using new ring in a used piston, check for uneven groove wear. The ring should fit perfectly parallel to the groove side. If not, replace the piston.*

### Piston Ring Groove Width Inspection

- Measure the groove width at several points around the piston with a vernier caliper.



## 80 MAINTENANCE AND ADJUSTMENT

### Piston Ring Groove Width

Standard	KX85C	1.01 ~ 1.03 mm (0.0398 ~ 0.0406 in.)
	KX100F	1.03 ~ 1.05 mm (0.0406 ~ 0.0413 in.)
Service Limit	KX85C	1.11 mm (0.0437 in.)
	KX100F	1.13 mm (0.0445 in.)

- If any of the groove widths exceeds the service limit, replace the piston.

### *Piston, Piston Pin, and Connecting Rod Wear Inspection*

- Visually inspect the snap rings still fitted in place.
- If the snap ring shows weakness or deformation, replace the ring. Also if the piston pin hole groove shows excessive wear, replace the piston.
- Measure the diameter of the piston pin with a micrometer.

### Piston Pin Diameter

Standard	13.995 ~ 14.000 mm (0.55098 ~ 0.55118 in.)
Service Limit	13.96 mm (0.5496 in.)

- If the piston pin diameter is less than the service limit at any point, replace the piston pin.
- Using a cylinder gauge, measure the diameter of the both of piston pin holes in the piston and the inside diameter of the connecting rod small end.

### Piston Pin Hole Diameter

Standard	14.001 ~ 14.011 mm (0.55122 ~ 0.55161 in.)
Service Limit	14.08 mm (0.5543 in.)

### Connecting Rod Small End Inside Diameter

Standard	18.002 ~ 18.013 mm (0.70874 ~ 0.70917 in.)
Service Limit	18.05 mm (0.7106 in.)

- If either piston pin hole diameter exceeds the service limit, replace the piston.
- If the inside diameter of the connecting rod small end exceeds the service limit, replace the crankshaft assembly.
- Check the needle bearing.

### NOTE

- *The rollers in a needle bearing normally wear very little, and wear is difficult to measure. Instead of measuring, inspect the bearing for abrasion, color change or other damage.*
- If there is any doubt as to the condition of a needle bearing, replace the bearing and piston pin.

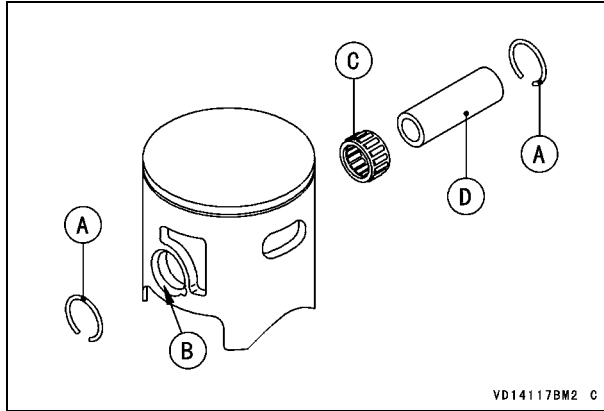

- A. Snap Ring**
- B. Pin Hole**
- C. Needle Bearing**
- D. Piston Pin**

***Piston Installation***

- Install all parts in the reverse order of removal.
- Stuff a clean cloth into the crankcase opening around the connecting rod so that no parts will fall into the crankcase.

- Scrape off any carbon off of the piston, then lightly polish the piston with fine emery cloth.
- Clean carbon and dirt out of the piston ring grooves using a suitable tool.

**NOTICE**

**Carbon particles can be very abrasive to piston ring. Don't allow such particles to fall onto the cylinder walls.**

- The ring is identical in KX100 model, but they are different in KX85 model.
- The piston ring is marked as follow:

KX85C	1N
KX100F	N

- First fit one end of the piston ring against the pin in the ring groove, spread the ring opening with the other hand and then slip the ring into the groove.

**NOTE**

- *Install the ring so that the marked side faces upward.*

## 82 MAINTENANCE AND ADJUSTMENT

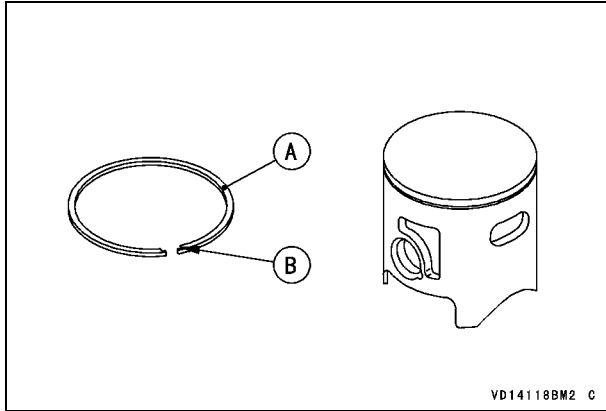

- A. Piston Ring
- B. Marked side

- Install the piston ring so that the pin in the piston ring groove is between the ends of the piston ring.

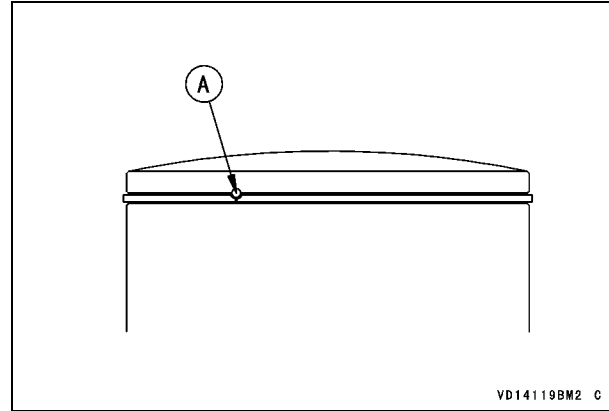

- A. Pin

- Apply 2-stroke engine oil to the connecting rod needle bearing and the piston pin.

### NOTE

- Install the piston with its mark facing forward.
- Install the piston with "IN" mark facing backward (KX85C).

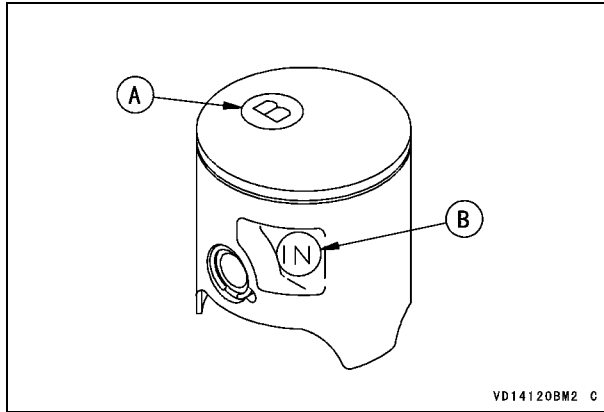

- A. Mark
- B. "IN" Mark (KX85C)

- When installing a piston pin snap ring, compress it only enough to install it and no more.

### NOTICE

**Do not reuse snap rings, as removal weakens and deforms them. They could fall out and score the cylinder wall.**

- Fit a new piston pin snap ring into the side of the piston so that the snap ring opening does not coincide with the notch in the edge of the piston pin hole.

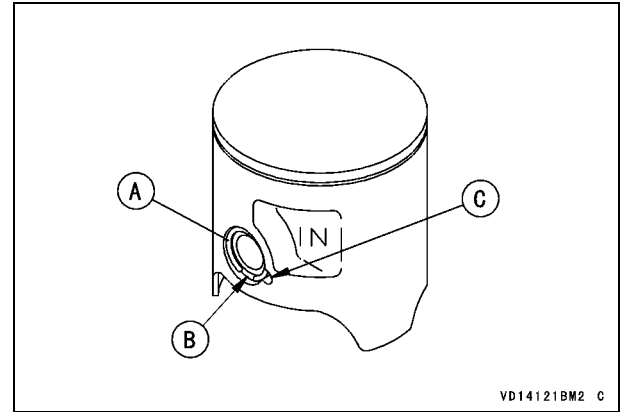

- A. Piston Pin Snap Ring
- B. Snap Ring Ends
- C. Notch

### Cylinder Installation

- Scrape any carbon out of the exhaust port.
- Check for mineral deposits and rust in the cylinder water jacket, and remove them if necessary.
- Replace the cylinder base gasket with a new one.
- Apply 2-stroke engine oil to the piston surface, piston ring and cylinder bore.
- Check to see that the pin in the piston ring groove is between the ends of the piston ring, and fit the base of the cylinder over the ring, pressing in on opposite side of the piston ring as necessary. Be certain that the ring does not slip out of position.

## 84 MAINTENANCE AND ADJUSTMENT

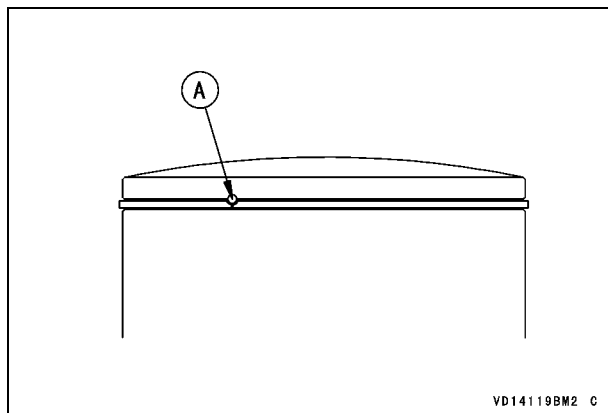

### A. Pin

- Tighten the cylinder nuts to the specified torque in a crisscross pattern.

### Tightening Torque

Cylinder Nuts:  
25 N·m (2.5 kgf·m, 18 ft·lb)

### Cylinder Head Installation

- Replace the cylinder head gasket with a new one.
- Scrape out any carbon and clean the cylinder head with a high flash-point solvent.
- Check for mineral deposits and rust in the cylinder head water jacket, and remove them if necessary.
- Install the dowel pins.
- Install a new cylinder head gasket with the side marked UP facing up.



### A. Dowel Pins

### B. Mark

- Tighten the cylinder head nuts to the specified torque in a crisscross pattern.

### Tightening Torque

Cylinder Head Nuts:  
25 N·m (2.5 kgf·m, 18 ft·lb)

- Install the spark plug and connect the two water hoses.
- Replace the engine bracket mounting nuts with new ones.
- Install the engine bracket and tighten the nuts to the specified torque.

### Tightening Torque

Engine Bracket Mounting Nuts:  
29 N·m (3.0 kgf·m, 21 ft·lb)

- Link the link lever to the link pin and insert the circlip to the KIPS shaft lever.
- Replace the exhaust gasket with a new one.
- Replace the exhaust O-rings with new ones.
- Apply molybdenum disulfide grease around the exhaust O-rings.

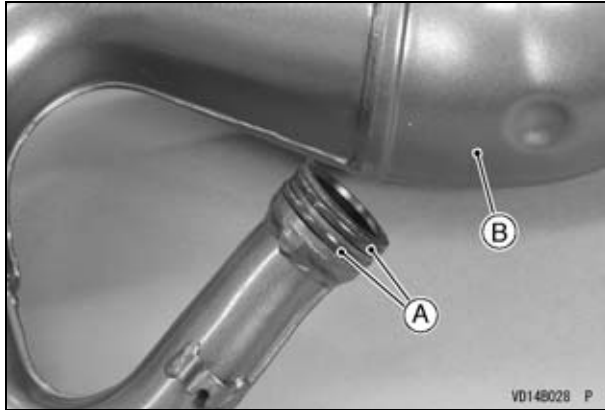

**A. Exhaust O-rings**  
**B. Expansion Chamber**

- Install the expansion chamber.
- Install the expansion chamber mounting springs as shown.

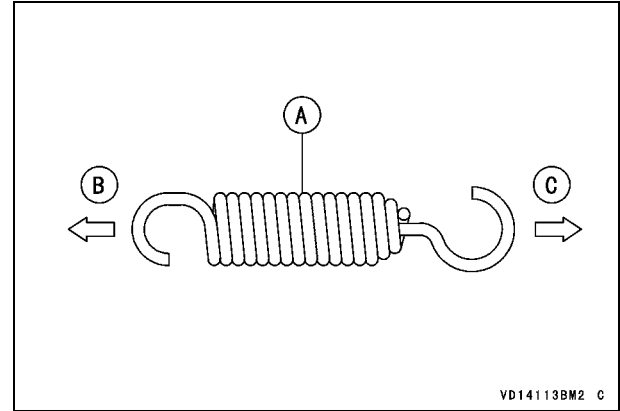

**A. Expansion Chamber Mounting Spring**  
**B. Cylinder Side**  
**C. Expansion Chamber Side**

- Install the muffler (see Exhaust System section).
- Install the spark plug cap.
- Pull up the spark plug cap lightly to make sure of the installation of the spark plug cap.
- Install the radiator and clamp.
- Run the overflow hose and water hoses correctly.
- Tighten the water hose clamp screws to the specified torque.

**Tightening Torque**

Water Hose Clamp Screws:  
3.0 N·m (0.31 kgf·m, 27 in·lb)

- Install the radiator screen so that the projections fit into the holes.

## 86 MAINTENANCE AND ADJUSTMENT

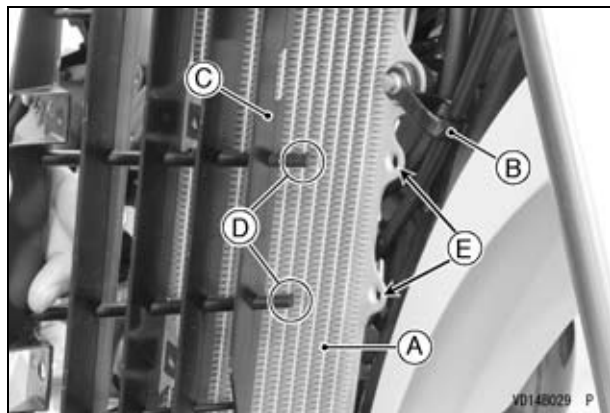

- A. Radiator**
- B. Clamp**
- C. Radiator Screen**
- D. Projections**
- E. Holes**

- Install the shroud screen so that the projections fit into the holes.

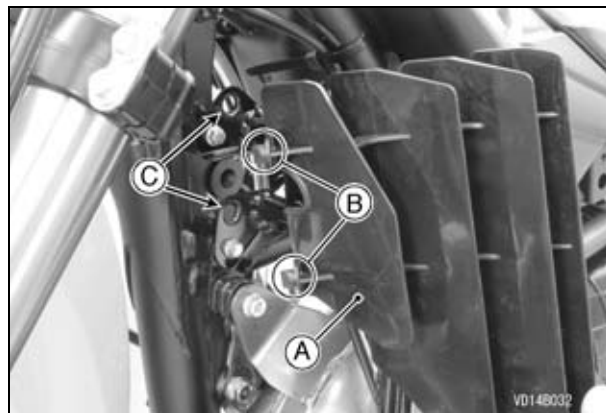

- A. Shroud Screen**
- B. Projections**
- C. Holes**

- Install the removed parts.
- Fill the coolant and check the coolant level (see Cooling System section).

---

## Exhaust System

---

The exhaust system, in particular the muffler body, is designed to reduce exhaust noise and conduct the exhaust gases away from the rider while minimizing power loss. If carbon has built up inside the muffler body, exhaust efficiency is reduced, causing engine performance to drop.

If the muffler body is badly damaged, dented, cracked or rusted, replace it. Replace the silencer wool if the exhaust noise becomes too loud or engine performance drops.

### *Silencer Wool Replacement*

- Remove the seat bolt and side cover bolt.
- Remove the left side cover.

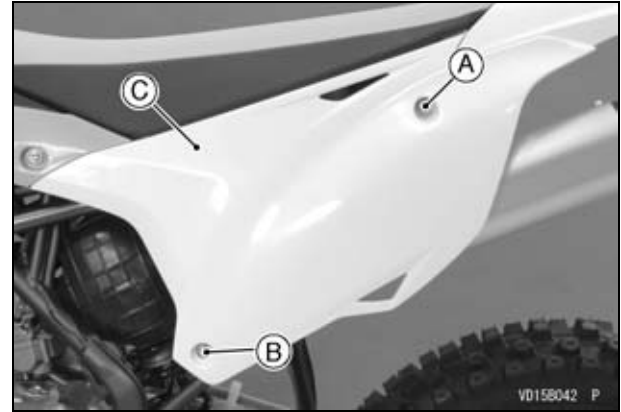

- A. Seat Bolt**
- B. Side Cover Bolt**
- C. Left Side Cover**



## 88 MAINTENANCE AND ADJUSTMENT

- Remove the muffler mounting bolts and washer, and pull the muffler off toward the rear.

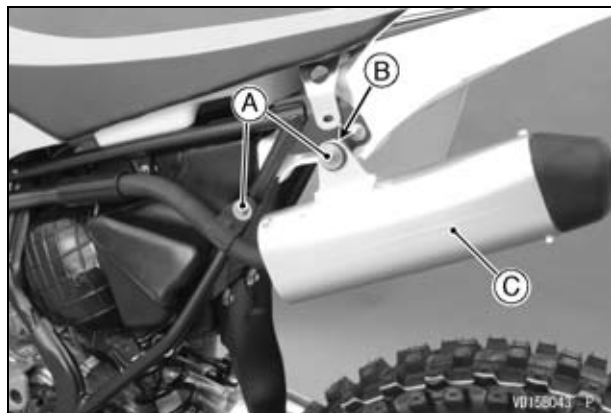

- A. Muffler Mounting Bolts
- B. Washer
- C. Muffler

- Remove the liquid gasket on the silencer, tail pipe and baffle.
- Remove the muffler body cover bolts, and pull out the tail pipe.

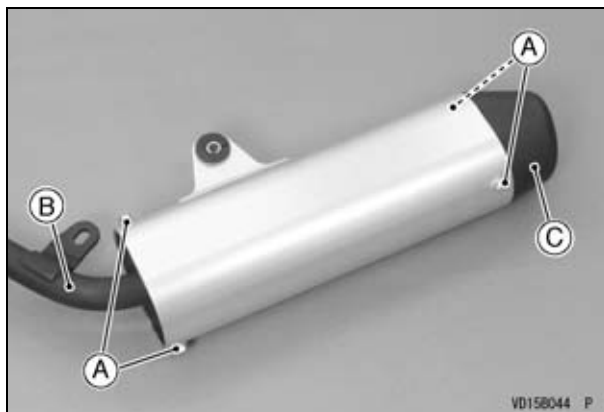

- A. Muffler Body Cover Bolts
- B. Tail Pipe
- C. Baffle

- Remove the O-ring between the silencer wool and tail pipe.

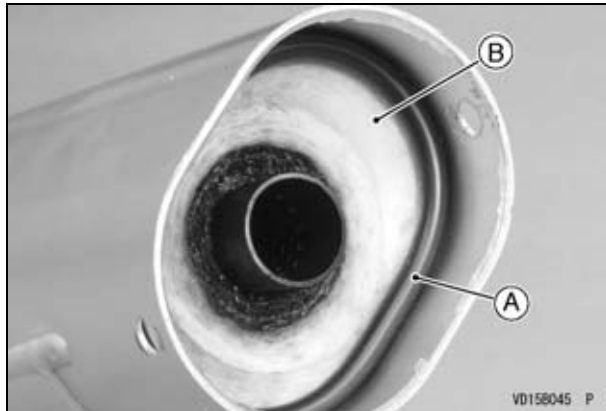

**A. O-ring**  
**B. Silencer Wool**

- Push out the baffle by tapping the inner pipe with a suitable tool.
- Pull off the silencer wool.

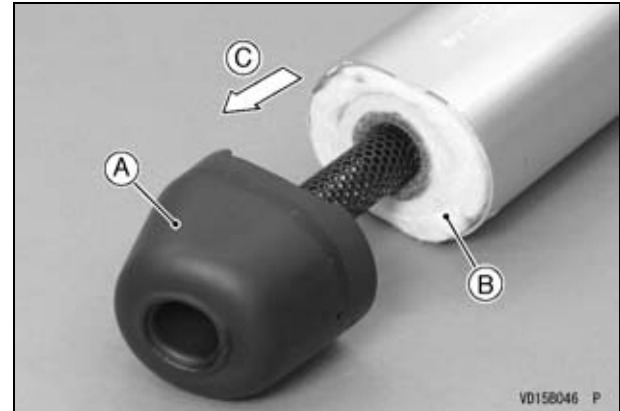

**A. Baffle**  
**B. Silencer Wool**  
**C. Push Out**

- Replace the silencer wool and O-ring with new ones.
- Install the silencer wool into the silencer.
- Install the O-ring.
- Using a high flash-point solvent, clean off any oil or dirt that may be on the liquid gasket coating area. Dry them with a clean cloth.
- Apply liquid gasket to the joint part of the silencer and tail pipe.

## 90 MAINTENANCE AND ADJUSTMENT

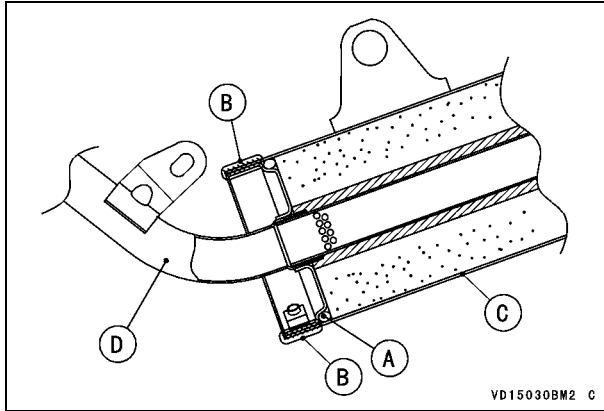

- A. O-ring**
- B. Liquid Gasket**
- C. Silencer**
- D. Tail Pipe**

- Install the baffle and then install the tail pipe into the silencer.
- Apply a non-permanent locking agent to thread of the muffler body cover bolts.
- Tighten the muffler body cover bolts to the specified torque.

### **Tightening Torque**

Muffler Body Cover Bolts:  
8.8 N·m (0.90 kgf·m, 78 in·lb)

- Install the muffler.

- Using a high flash-point solvent, clean off any oil or dirt that may be on the liquid gasket coating area. Dry them with a clean cloth.
- Apply liquid gasket to the joint part of the silencer and baffle.

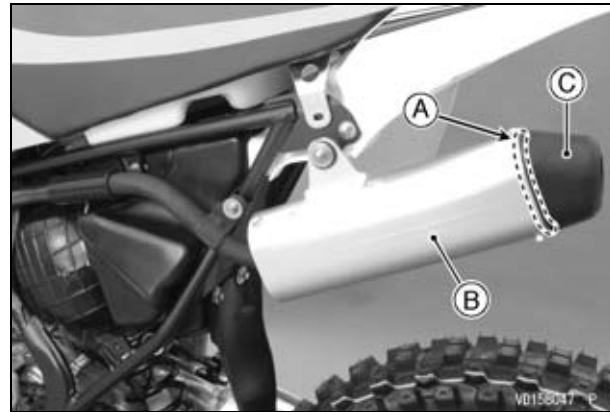

- A. Liquid Gasket**
- B. Silencer**
- C. Baffle**

- Install the left side cover.

## Drive Chain

For safety and to prevent excessive wear, the drive chain must be checked, adjusted, and lubricated in accordance with the Periodic Maintenance Chart. If the chain becomes badly worn or maladjusted - either too loose or too tight - it could jump off the sprockets or break.

### WARNING

**A chain that breaks or jumps off the sprockets could snag on the engine sprocket or lock the rear wheel, severely damaging the motorcycle and causing it to go out of control. Inspect the chain for damage and proper adjustment before each ride.**

### *Drive Chain Slack Inspection*

- With the motorcycle on its side stand, rotate the rear wheel to find the place where the chain is tightest (because it wears unevenly).
- Rotate the rear wheel to find the position where the chain is tightest.
- Push up the drive chain in the middle of the upper chain run to measure the chain slack. The distance between the bottom-line of the chain and the swingarm (at the end of the chain slipper) should be within the standard value.

### Drive Chain Slack

Standard	54 ~ 64 mm (2.1 ~ 2.5 in.)
----------	----------------------------

- Adjust the drive chain if its slack is out of specification.



A. Drive Chain Slack

- In addition to checking the slack, rotate the rear wheel to inspect the drive chain for damaged rollers, loose pins and links and the sprockets for unevenly or excessively worn and damaged teeth.
- If there are any such defects, replace the drive chain and/or the sprockets.

### *Drive Chain Slack Adjustment*

- Remove the cotter pin from the rear axle.
- Loosen the rear axle nut and both chain adjuster locknuts.
- Turn both chain adjusting bolts evenly until the drive chain slack (measured between the chain and the swingarm) is within the standard value. If

## 92 MAINTENANCE AND ADJUSTMENT

the chain is too tight, back out the left and right chain adjusting bolts evenly, and kick the wheel forward. If the chain is too loose, turn both chain adjusting bolts evenly until the drive chain has the correct amount of slack. To keep the chain and wheel properly aligned, the notch on the right chain adjuster should align with the same swingarm mark as the left chain adjuster notch aligned with.

### Drive Chain Slack

54 ~ 64 mm (2.1 ~ 2.5 in.)

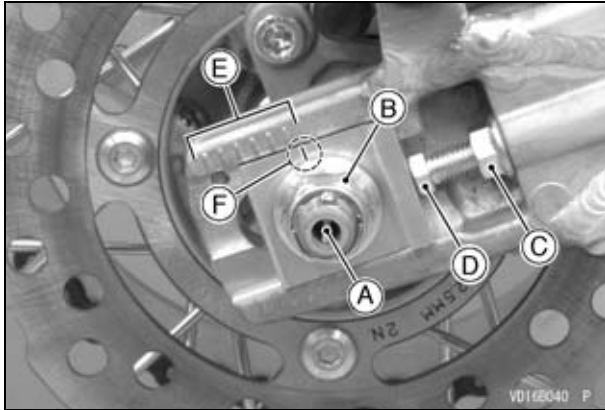

- A. Cotter Pin
- B. Rear Axle Nut
- C. Chain Adjuster Locknut
- D. Adjusting Bolt
- E. Marks
- F. Notch

### NOTE

- *Wheel alignment can also be checked using the straightedge or string method.*

### **⚠** WARNING

**Misalignment of the wheel will result in abnormal wear, and may result in an unsafe riding condition. Align the rear wheel using the marks on the swingarm or measuring the distance between the center of the axle and swingarm pivot.**

- Tighten both chain adjuster locknuts.
- Tighten the rear axle nut to the specified torque.

### Tightening Torque

Rear Axle Nut:  
78 N·m (8.0 kgf·m, 58 ft·lb)

- Rotate the wheel, measure the chain slack again at the tightest position, and readjust it if necessary.
- Install a new cotter pin through the rear axle, and bend its ends.

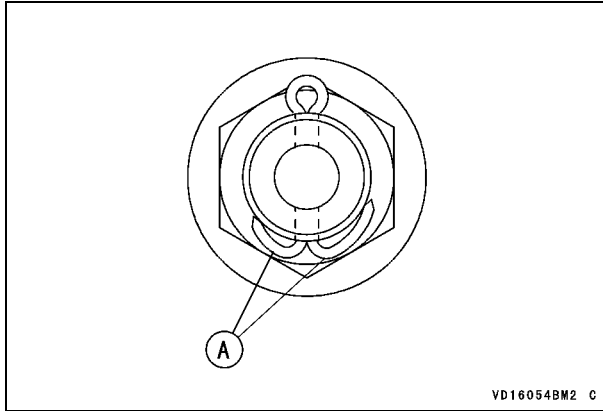

**A. Cotter Pin**

**⚠ WARNING**

**A loose axle nut can lead to an accident resulting in serious injury or death. Tighten the axle nut to the proper torque and install a new cotter pin.**

- Check the rear brake effectiveness.

**NOTE**

- *When riding in wet and muddy conditions, mud sticks to the chain and sprockets, resulting in an*

*overly tight chain, which can cause it to break. To prevent this, adjust the chain slack (measured between the chain and the swingarm) to 64 ~ 74 mm (2.5 ~ 2.9 in.).*

**Chain Wear Inspection**

When the chain has reached its wear limit (i.e., when it has stretched by 1.7% of its original length), it is no longer safe for use and should be replaced. Since it is impractical to measure the entire length of the chain, determine the degree of wear by measuring a 20-link section of the chain.

- Tighten the chain either by using the chain adjusters or by hanging a 10 kg (22 lb) weight on the chain.
- Measure the 20-link length on a straight part of the chain from the center of the 1st pin to the center of the 21st pin. If the length exceeds the service limit, the chain should be replaced. Since over-worn sprockets will cause a new chain to wear faster, inspect both the engine and rear sprockets whenever the chain is replaced, and replace them if necessary.

## 94 MAINTENANCE AND ADJUSTMENT

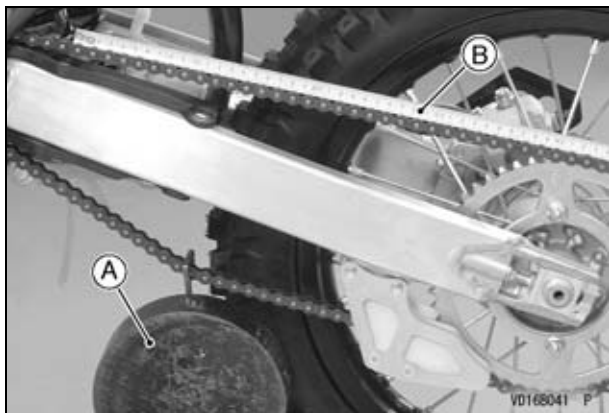

- A. Weight
- B. Tape Measure

### Drive Chain 20-link Length

Standard	254.0 ~ 254.6 mm (10.00 ~ 10.02 in.)
Service Limit	259 mm (10.2 in.)

### NOTE

- The drive system was designed for use with a DAIDO DID 420DS2 chain (KX85C: 120-links, KX100F: 124-links). For maximum stretch resistance and safety, a genuine part must be used for replacement.

- To minimize any chance of the master link coming apart, the master link clip must be installed with the closed end of the "U" pointing in the direction of chain rotation.

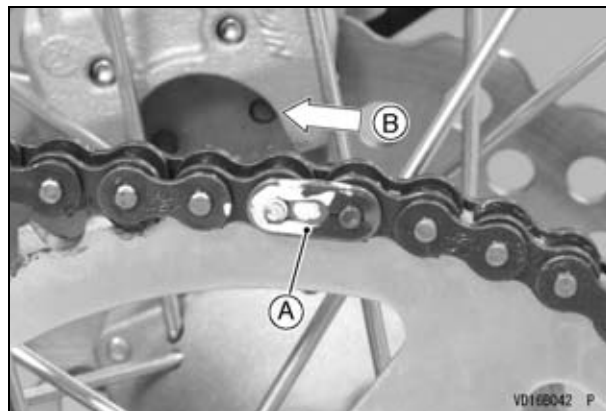

- A. Master Link Clip
- B. Direction of Chain Rotation

*Chain Guide Wear Inspection*

- Visually inspect the drive chain guide and replace it if excessively worn or damaged.



**A. Drive Chain Guide**

*Chain Slipper Wear Inspection*

- Visually inspect the upper and lower of the chain slipper on the swingarm and replace them if worn or damaged.

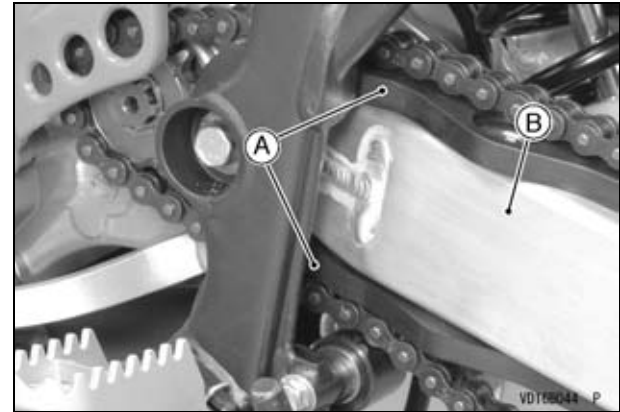

**A. Upper and Lower of the Chain Slipper  
B. Swingarm**

*Sprocket Wear Inspection*

- Visually inspect the sprocket teeth and replace the sprocket if its teeth are worn or damaged.



## 96 MAINTENANCE AND ADJUSTMENT

### Sprocket Teeth Wear

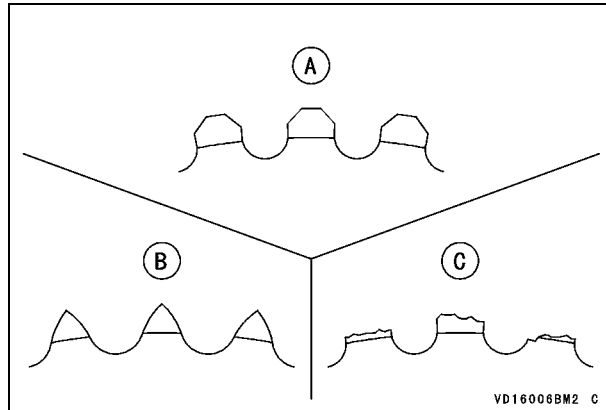

- A. Good Teeth
- B. Worn Teeth
- C. Damaged Teeth

### NOTE

○ *Sprocket wear is exaggerated in the illustration.*

### Chain Lubrication

Lubrication is necessary after riding through rain or on wet roads, or any time that the chain appears dry.

Use a lubricant for drive chains. If the chain is especially dirty, clean it using a cleaner for drive

chains following the instructions supplied by the chain cleaner manufacturer.

- Apply lubricant to the sides of the rollers so that it will penetrate to the rollers and bushings. Wipe off any excess lubricant.

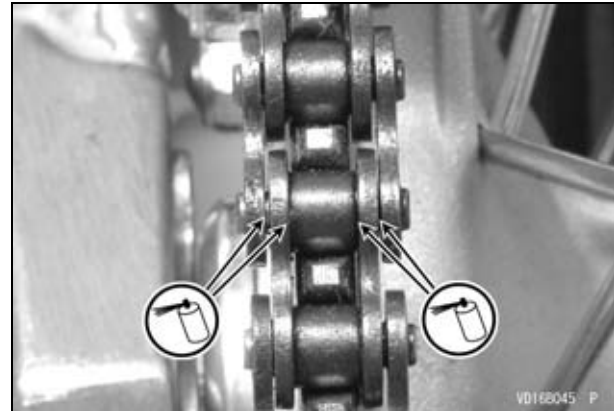

- Wipe off any lubricant that gets on the tire surface.

---

## Handlebar

---

### *Handlebar Removal*

- Unlock the clamp of the number plate (see Steering section).
- Remove the handlebar holder bolts, the handlebar holders and the handlebars.

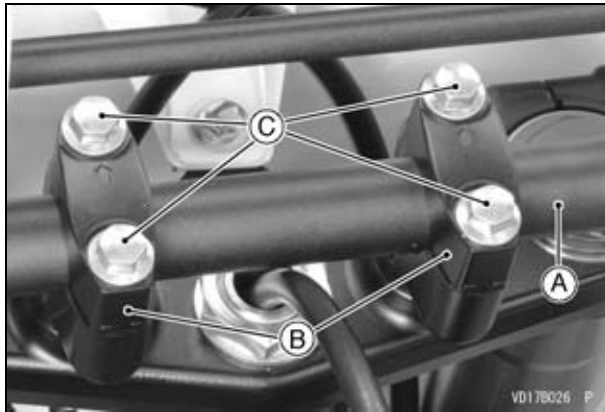

- A. Handlebars**
- B. Handlebar Holders**
- C. Handlebar Holder Bolts**

- Check the handlebars for bent or crack.

### *Handlebar Installation*

- Apply 2-stroke oil to the thread of the handlebar holder bolts.

- Install the holders so that the arrow marks on the holders point at the front.
- Align the punch mark on the handlebars with a gap at rear of the handlebar holder.

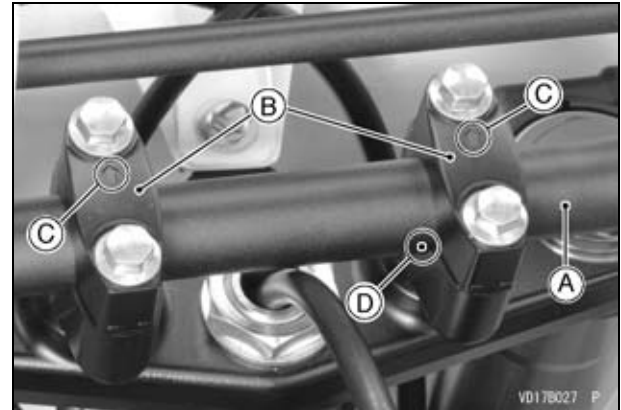

- A. Handlebars**
- B. Handlebar Holders**
- C. Arrow Marks**
- D. Punch Mark**

- Tighten the front handlebar holder bolts first and then the rear ones. If the handlebar holders are correctly installed, there will be no gap at the front and a gap at the rear after tightening.

## 98 MAINTENANCE AND ADJUSTMENT

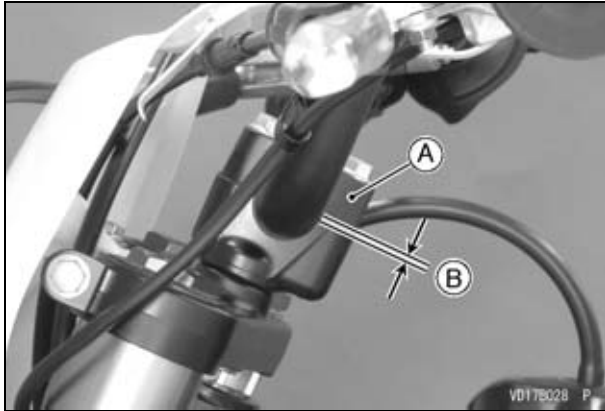

- A. Handlebar Holders
- B. Gap

### Tightening Torque

Handlebar Holder Bolts:  
25 N·m (2.5 kgf·m, 18 ft·lb)

- Check the front brake for the proper brake effect, or no brake drag.

### Handlebar Height Adjustment

The handlebar height can be adjusted in the two positions (5 mm or 10 mm higher than standard setting).

- Remove the handlebars (see Handlebar Removal in this section).
- Check the handlebars for bent or crack.
- Remove the handlebar holder nuts and washers, and the handlebar holders.

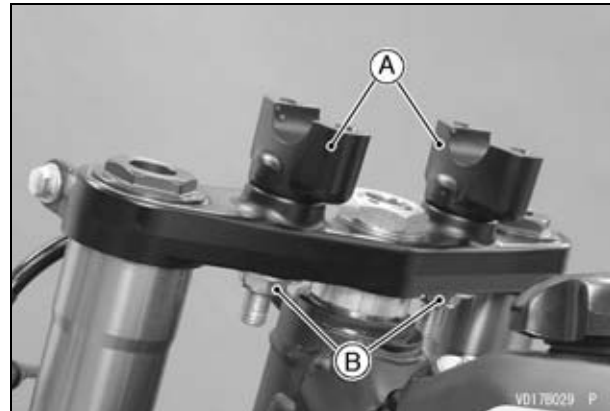

- A. Handlebar Holders
- B. Handlebar Holder Nuts and Washers

- Select the handlebar height as follows.
- Install the collars between the handlebar holders and steering stem head.

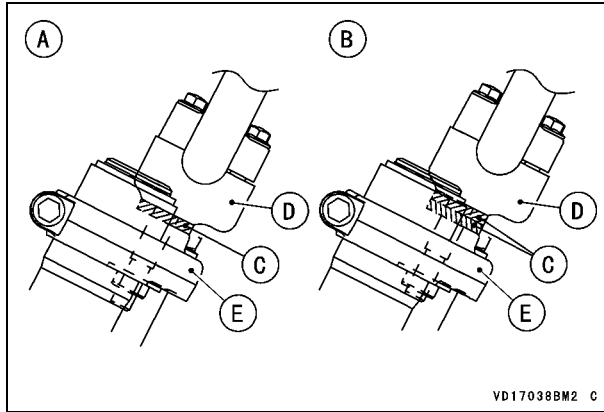

- A. 5 mm Higher than Standard Setting**
- B. 10 mm Higher than Standard Setting**
- C. Collars**
- D. Handlebar Holder (Both Sides)**
- E. Steering Stem Head**

- Replace the handlebar holder nuts with new ones.
- Install the handlebar holders, the handlebar holder nuts and washers.
- Tighten the handlebar holder nuts to the specified torque.

### Tightening Torque

Handlebar Holder Nuts:  
34 N·m (3.5 kgf·m, 25 ft·lb)

- Install the handlebars (see Handlebar Installation in this section).

### Handlebar Position Adjustment

To suit various riding positions, the handlebar position can be adjusted by turning the handlebar holders around.

- Remove the handlebars (see Handlebar Removal in this section).
- Check the handlebars for bent or crack.
- Remove the handlebar holder nuts and washers, and the handlebar holders.

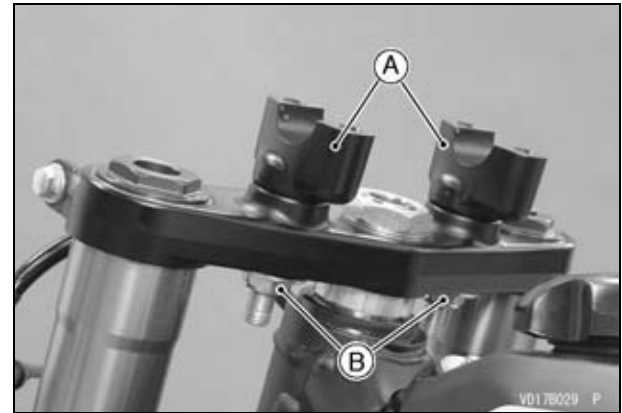

- A. Handlebar Holders**
- B. Handlebar Holder Nuts and Washers**

- Turn the handlebar holders 180°.
- Put the handlebars on the handlebar holders.
- Replace the handlebar holder nuts with new ones.
- Install the handlebar holders, the handlebar holder nuts and washers.
- Tighten the handlebar holder nuts to the specified torque.

## 100 MAINTENANCE AND ADJUSTMENT

### Tightening Torque

Handlebar Holder Nuts: 34 N·m (3.5 kgf·m, 25 ft·lb)
--

- Install the handlebars (see Handlebar Installation in this section).

---

### Brakes

---

Disc and disc pad wear is automatically compensated for and has no effect on the brake lever or pedal action. There are no parts on the brakes that require adjustment except brake lever position.

#### *Brake Lever Position*

The brake lever position can be adjusted to suit the rider's preference.

- To adjust the brake lever position, slide the front brake lever dust cover back, and loosen the locknut, and turn the adjuster to either side with a wrench.
- After adjustment, tighten the locknut securely.

 <b>WARNING</b>
---

<p><b>An improperly adjusted brake could drag and cause the brake to overheat, damaging the brake assembly and possibly locking the rear wheel, resulting in loss of control. Always maintain the proper brake adjustment.</b></p>
--

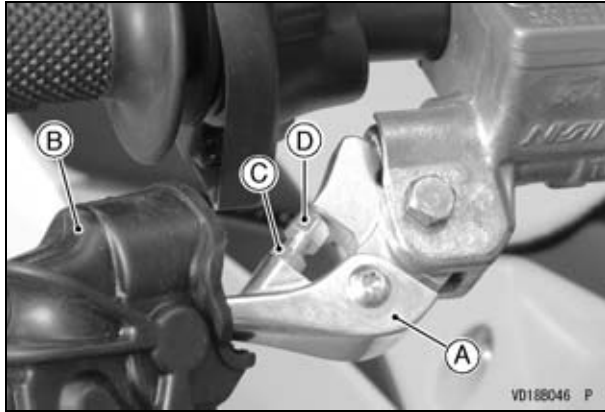

- A. Brake Lever
- B. Dust Cover
- C. Locknut
- D. Adjuster

- Test the braking power and check that there is no brake drag.

**⚠ WARNING**

Air in the brake lines diminish braking performance and can cause an accident resulting in injury or death. If the brake lever or pedal feels mushy when it is applied, there might be air in the brake lines or the brake may be defective. Have the brake checked immediately by an authorized Kawasaki dealer.

*Disc Brake Fluid*

Inspect the brake fluid level in the front and rear brake reservoirs and change the brake fluid in accordance with the Periodic Maintenance Chart. The brake fluid should also be changed when contaminated with dirt or water.

Use only heavy-duty brake fluid as follows.

Front: DOT3 or DOT4

Rear: DOT4

**NOTE**

- *The motorcycle is shipped with brake fluid DOT4 in the brake system.*

**NOTICE**

**Do not spill brake fluid onto any painted surface.**

**Do not use fluid from a container that has been left open or that has been unsealed for a long time.**

**Check for fluid leakage around the brake system fittings.**

**Check for brake hose damage.**

*Brake Fluid Level Inspection*

**Front Brake Reservoir**

With the front brake reservoir positioned horizontally, the brake fluid must always be above the lower level line.

## 102 MAINTENANCE AND ADJUSTMENT

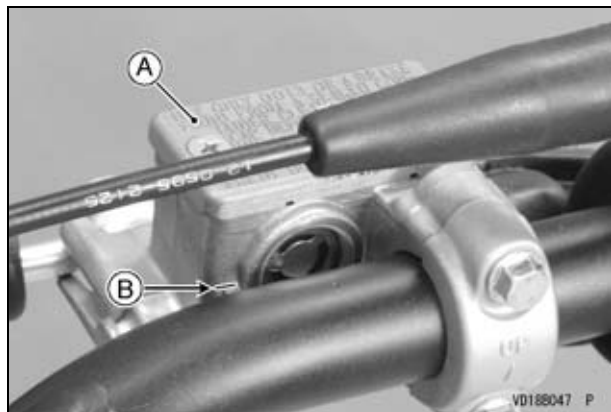

**A. Front Brake Reservoir**  
**B. Lower Level Line**

- If the brake fluid in the front brake reservoir is below the lower level line, check for fluid leaks in the brake line and add brake fluid as follows.
- Remove the screws and the front brake reservoir cap.

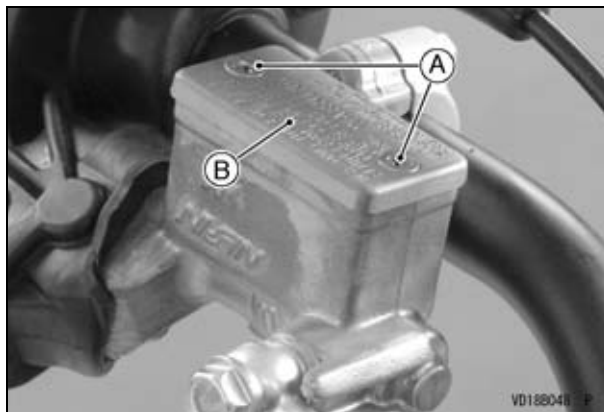

**A. Front Brake Reservoir Cap Screws**  
**B. Front Brake Reservoir Cap**

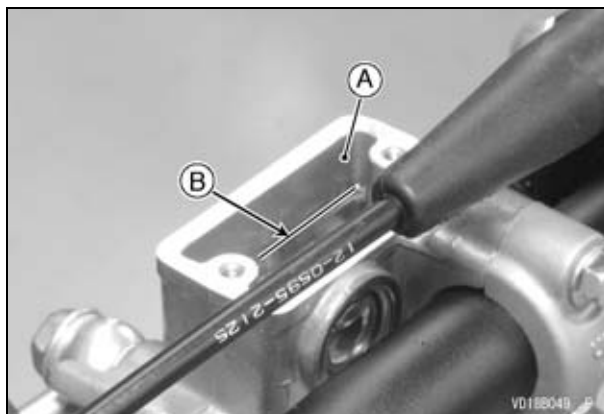

**A. Front Brake Reservoir**  
**B. Upper Level Line**

**⚠ WARNING**

Mixing brands and types of brake fluid can reduce the brake system's effectiveness and cause an accident resulting in injury or death. Do not mix two brands of brake fluid. Change the brake fluid in the brake line completely if the brake fluid must be refilled but the type and brand of the brake fluid that is already in the reservoir are unidentified.

- Install the front brake reservoir cap.
- Tighten the screws to the specified torque.

**Tightening Torque**

Front Brake Reservoir Cap Screws:  
1.5 N·m (0.15 kgf·m, 13 in·lb)

**Rear Brake Reservoir**

With the rear brake reservoir positioned horizontally, the brake fluid must always be kept the upper level line.

- If the brake fluid is below the upper level line, check for fluid leaks in the brake line and add brake fluid as follows.
- Remove the rear brake reservoir mounting bolt and washer.
- Remove the rear brake reservoir cap.

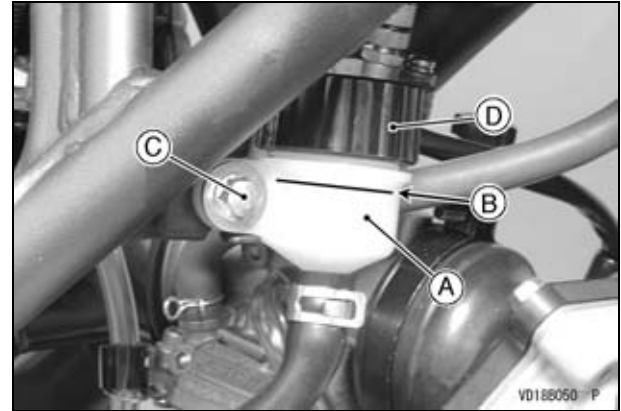

- A. Rear Brake Reservoir
- B. Upper Level Line
- C. Rear Brake Reservoir Mounting Bolt and Washer
- D. Rear Brake Reservoir Cap

**⚠ WARNING**

Mixing brands and types of brake fluid can reduce the brake system's effectiveness and cause an accident resulting in injury or death. Do not mix two brands of brake fluid. Change the brake fluid in the brake line completely if the brake fluid must be refilled but the type and brand of the brake fluid that is already in the reservoir are unidentified.

- Install the rear brake reservoir cap, mounting bolt and washer.



## 104 MAINTENANCE AND ADJUSTMENT

### NOTE

- First, until slight resistance is felt indicating that the cap is seated on the reservoir body; then, tighten the cap an additional 1/6 turn while holding the brake fluid reservoir body.

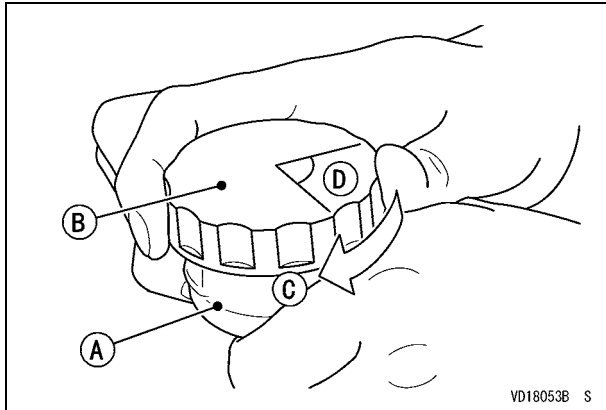

- A. Reservoir
- B. Cap
- C. Clockwise
- D. 1/6 turn

### Brake Pad Wear Inspection

Inspect the brake pads for wear in accordance with the Periodic Maintenance Chart. If the thickness of any pad in any (front or rear) brake caliper is less than 1 mm (0.04 in.), have both pads in the caliper

replaced as a set. Pad replacement should be done by an authorized Kawasaki dealer.

### Brake Pads Lining Thickness

Standard	4.0 mm (0.16 in.)
Service Limit	1 mm (0.04 in.)

### Usable Brake Pad Range

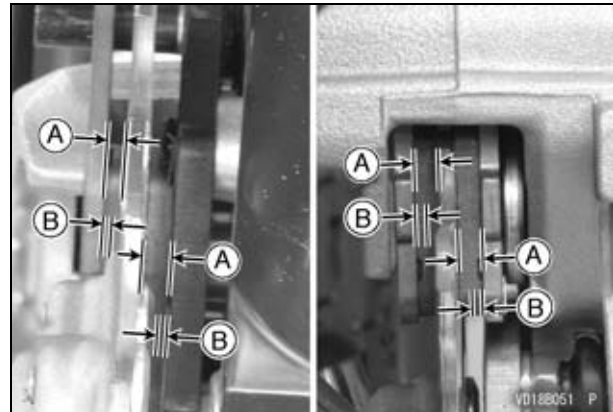

- A. Lining Thickness
- B. 1 mm (0.04 in.)

---

## Steering

---

The steering should always be kept adjusted so that the handlebars will turn freely but not have excessive play.

### *Steering Inspection*

- To check the steering adjustment, raise the front wheel off the ground using a jack (special tool: 57001-1238) and attachment (special tool: 57001-1608).
- Push the handlebars lightly to either side. If the handlebars continues moving under its own momentum, the steering is not too tight.
- Squatting in front of the motorcycle, grasp the lower ends of the front fork at the axle, and push and pull the front fork back and forth. If play is felt, the steering is too loose and needs to be adjusted.

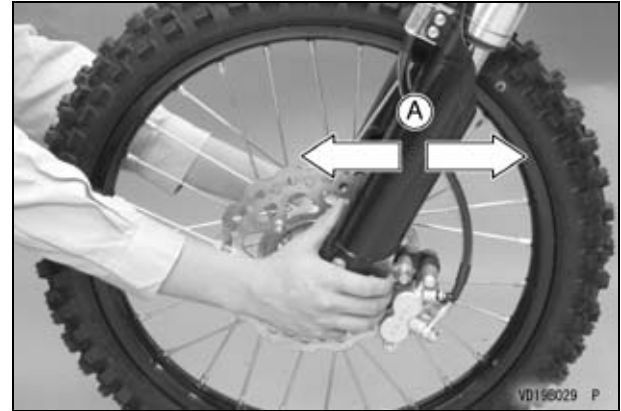

**A. Push and Pull**

### *Steering Adjustment*

- Raise the front wheel off the ground using a jack (special tool: 57001-1238) and attachment (special tool: 57001-1608).
- Unlock the clamp of the number plate.
- Remove the number plate mounting bolt.
- Clear the projections and remove the number plate.

## 106 MAINTENANCE AND ADJUSTMENT

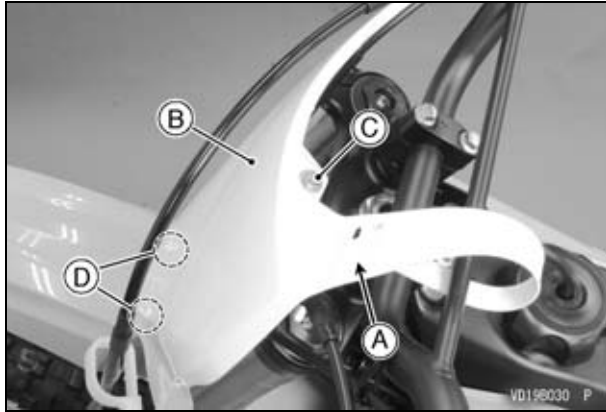

- A. Clamp**
- B. Number Plate**
- C. Number Plate Mounting Bolt**
- D. Projections**

- Remove the handlebars (see Handlebar section).
- Loosen the front fork clamp bolts (upper) on both sides (see Front Suspension section).

- Loosen the steering stem head nut.
- Turn the steering stem nut with a stem nut wrench (special tool: 57001-1100) to obtain the proper adjustment.

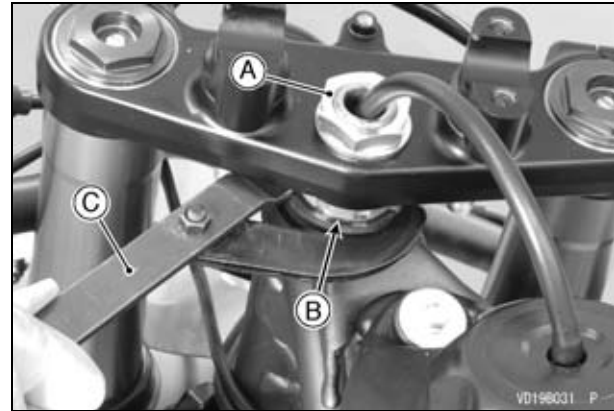

- A. Steering Stem Head Nut**
- B. Steering Stem Nut**
- C. Stem Nut Wrench (Special Tool: 57001-1100)**

- If the steering is too tight, loosen the stem nut a fraction of a turn; if the steering is too loose, tighten the nut a fraction of a turn.
- Turn the nut 1/8 turn at a time maximum.
- Tighten the steering stem head nut and the front fork clamp bolts (upper) to the specified torque.

### Tightening Torque

Steering Stem Head Nut:

64 N·m (6.5 kgf·m, 47 ft·lb)

Steering Stem Nut:

4.9 N·m (0.50 kgf·m, 43 in·lb)

Front Fork Clamp Bolts (Upper):

20 N·m (2.0 kgf·m, 15 ft·lb)

- Install the handlebars (see Handlebar section), and check the steering again and readjust it if necessary.
- Check the front brake for the proper brake effect, or no brake drag.
- Install the number plate so that the projections on the front fender fit into the holes in the number plate.

### NOTE

- *Run the brake hose through the front of the number plate.*

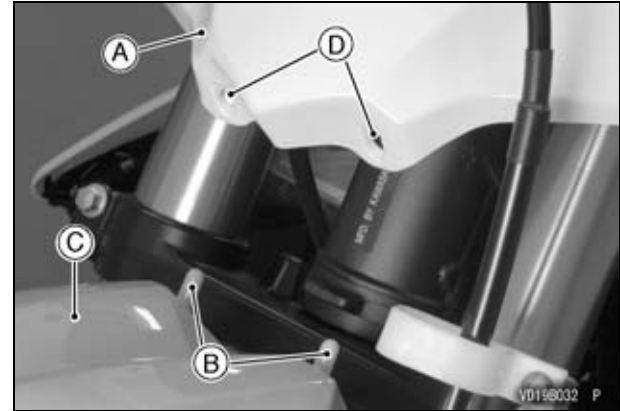

- A. Number Plate**
- B. Projections**
- C. Front Fender**
- D. Holes**

- Tighten the number plate mounting bolt.
- Lock the clamp of the number plate.

### Front Suspension

#### Front Fork Inspection

#### **NOTICE**

**Sticking muds or dusts on the sliding surface of the front fork could damage to the oil seal, leading to an oil leak. Clean the sliding surface after each ride.**

- Holding the brake lever, pump the front fork back and forth manually to check for smooth operation.
- Visually inspect the front fork for oil leakage, scoring or scratches on the outer surface of the inner tube.
- If necessary, replace by an authorized Kawasaki dealer.

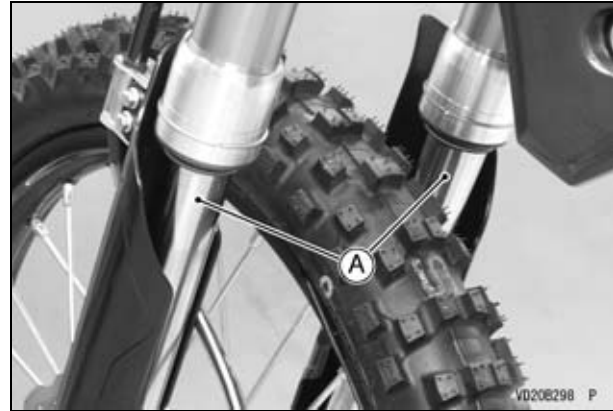

**A. Inner Tubes**

#### **NOTICE**

**If the inner tube is badly bent or creased, replace it. Excessive bending, followed by subsequent straitening, can weaken the inner tube.**

#### Front Fork Adjustment

Any of the following front fork adjustments should be made to tune the front suspension to the rider's weight and the condition of the track.

Basically, there are five adjustments you can make to the front fork.

- **Air Pressure Adjustment**

Air pressure acts as a progressive spring over the entire fork travel range. Since the air pressure in the fork legs increases with normal use, the fork action

on your KX will get stiffer as the race progresses. Therefore, it is not recommended to increase the air pressure for additional springing. The KX forks are designed to function without added air.

- **Compression Damping Adjustment**

This adjustment affects how quickly the fork compresses. The fork compression damping adjuster has at least 20 positions. The fully seated position (adjuster turned fully clockwise) is the hardest setting. Turning the adjuster counterclockwise (KX85C: 10 clicks, KX100F: 14 clicks) from the fully seated position is the standard setting, turning it counterclockwise 20 or more clicks is the softest setting.

- **Fork Oil Level Adjustment**

The fork oil level affects only the final 100 mm (4 in.) of fork travel. A higher oil level will make the fork rebound more quickly. A lower oil level will make the fork rebound more slowly.

- **Optional Fork Springs**

Optional springs, softer and stiffer than standard, are available.

- **Fork Height**

Steering is greatly affected by the fork height (how much the outer fork tubes protrude above the upper fork clamp). The less the fork tube protrudes, the lighter the front end becomes and the greater the tendency for understeering and washout due to weight biasing. Increasing the amount of fork tube protrusion has opposite effects. Be sure that the

front tire does not touch the fender when the fork is fully compressed. Make this adjustment in 10 mm (0.39 in.) steps.

**NOTICE**

**The right and left fork tubes must be adjusted evenly.**

*Air Pressure Adjustment*

The standard air pressure in the front fork legs is atmospheric (0 kPa, 0 kgf/cm<sup>2</sup>, 0 psi). Air pressure in the fork legs increase with normal use, so the fork action stiffens during operation. Release air pressure from the fork legs prior to each race through the air pressure relief screw located in front fork top plug. Make sure the front forks are fully extended with the front wheel off the ground when releasing the pressure.

- Raise the front wheel off the ground using a jack (special tool: 57001-1238) and attachment (special tool: 57001-1608).
- Remove the air pressure relief screw on each front fork top plug to let the air pressure equalize. Then, tighten the screws to the specified torque.

**Tightening Torque**

Air Pressure Relief Screws:  
1.3 N·m (0.13 kgf·m, 12 in·lb)

## 110 MAINTENANCE AND ADJUSTMENT

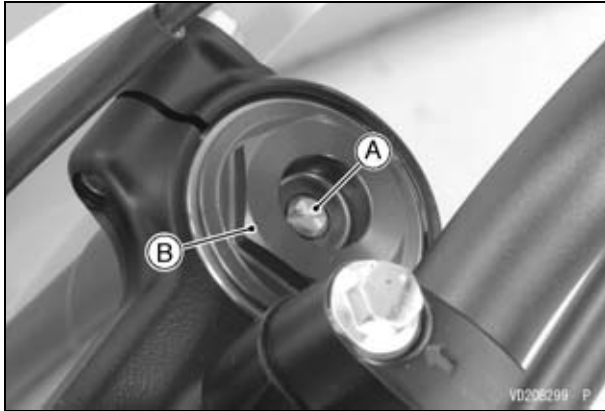

- A. Air Pressure Relief Screw
- B. Front Fork Top Plug

### *Compression Damping Adjustment*

- Raise the front wheel off the ground using a jack (special tool: 57001-1238) and attachment (special tool: 57001-1608).
- Clean the bottom of the fork tubes.
- Remove the caps on the bottom of the fork tubes.

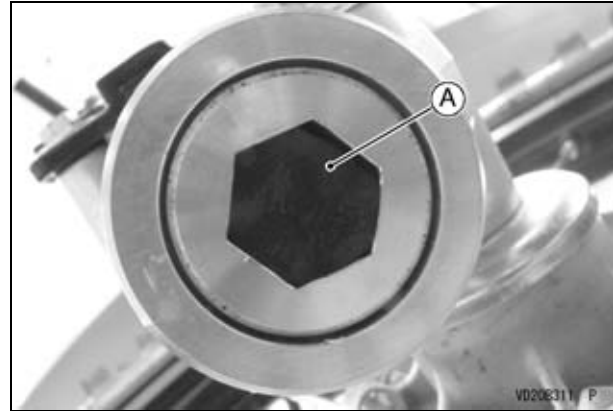

- A. Cap (Both Sides)

- To adjust the compression damping, turn the adjuster on the compression valve assembly with a standard tip screwdriver. Adjust the compression damping to suit your preference under certain conditions.

### ***NOTICE***

**Do not force the compression damping adjuster beyond the fully seated position, or the adjusting mechanism may be damaged.**

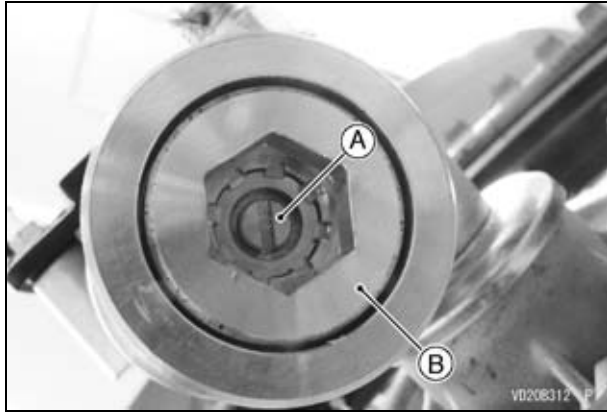

- A. Compression Damping Adjuster
- B. Compression Valve Assembly

### Compression Damper Settings

- A. Seated Position (Adjuster Turned Fully Clockwise)
- B. Softer (Counterclockwise)
- C. Harder (Clockwise)
- D. Standard Setting (KX85C)
- E. Standard Setting (KX100F)

\*: Number of turns counterclockwise usable range 20 clicks or more.

### Standard Compression Damper Setting

KX85C	10 clicks*
KX100F	14 clicks*

\*: Counterclockwise from the fully seated position

### NOTICE

The right and left fork tubes must be adjusted evenly.

- Install the caps on the bottom of the fork tubes.

### Fork Oil Level Adjustment

- Thoroughly clean the forks before disassembly.

### NOTICE

Be careful not to scratch the inner tube and not to damage the dust seal. Avoid scratching or damaging the inner tube or the dust seal. Use a mild detergent and sponge out dirt with plenty of water.

### NOTE

- Record the compression damper setting before disassembling.
- Set the compression damping to the softest settings before disassembly to prevent the needle of adjusters from damping.
- Remove the number plate (see Steering section).
- Remove the bolts and the front fender.



## 112 MAINTENANCE AND ADJUSTMENT

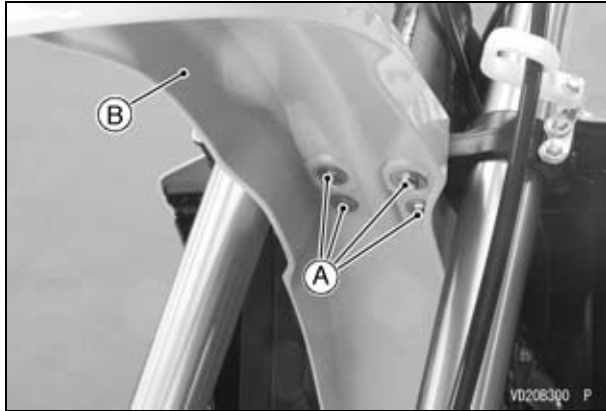

**A. Bolts**

**B. Front Fender**

- Loosen the front fork clamp bolts (upper).
- Loosen the front fork top plug.

### NOTE

○ *Do not take off the compression valve assembly.*

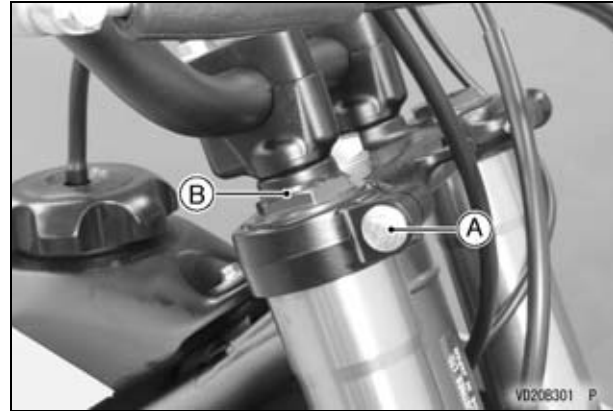

**A. Front Fork Clamp Bolt (Upper)**

**B. Front Fork Top Plug**

- Support the motorcycle using a jack (special tool: 57001-1238) and attachment (special tool: 57001-1608).
- Remove the bolts and the brake hose clamps.
- Remove the bolts and front fork protectors.

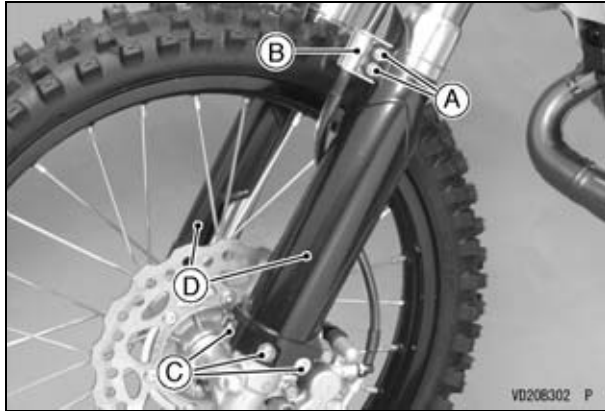

- A. Bolts
- B. Brake Hose Clamps
- C. Bolts (Both Sides)
- D. Front Fork Protectors

- Loosen the front fork top plugs, and take the top plugs with the push rods off.

**⚠ WARNING**

The top plugs are under extreme spring pressure and may eject with great force during service. Use care when removing the top plugs. Wear eye and face protection.

- Place a suitable stand under the engine to raise the front wheel off the ground.
- Slowly compress the front fork fully by pushing up the inner tube until its stepped portion contacts the dust seal on the lower end of the outer tube.

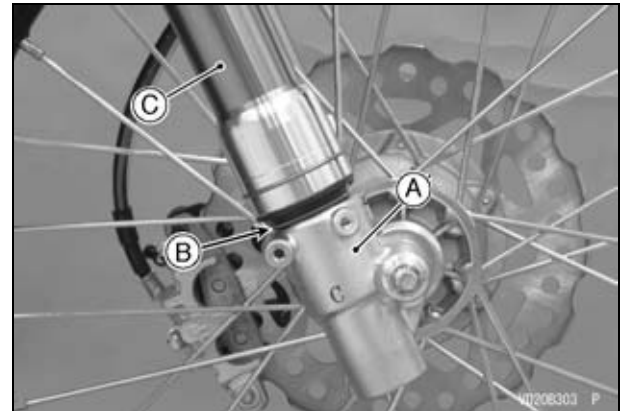

- A. Inner Tube (Stepped Portion)
- B. Dust Seal
- C. Outer Tube

- Place a stand or other suitable support under the front wheel.

## 114 MAINTENANCE AND ADJUSTMENT



- A. Suitable Support**
- B. Front Wheel**

- While holding the front fork push rod nut with a wrench, remove the front fork top plug from the top of the push rod.
- Remove the fork spring seat and fork spring.

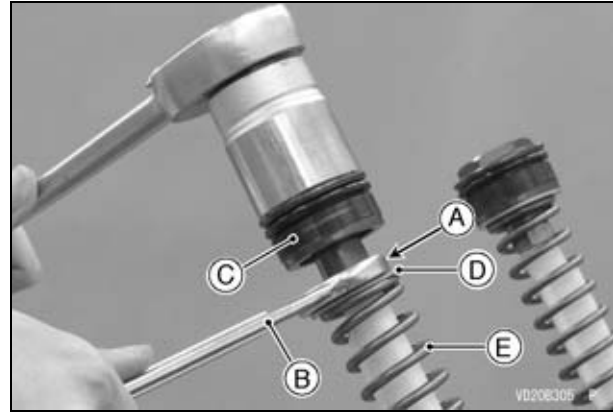

- A. Front Fork Push Rod Nut**
- B. Wrench**
- C. Front Fork Top Plug**
- D. Fork Spring Seat**
- E. Fork Spring**

- Remove the other fork spring in the same way as described above.
- Fill the front fork to the top of the inner tube with fork oil.

### Recommended Fork Oil

KHL15-10 (1 L): P/No. 44091-0004

- Install a push rod puller (special tool: 57001-1298) onto the push rod.

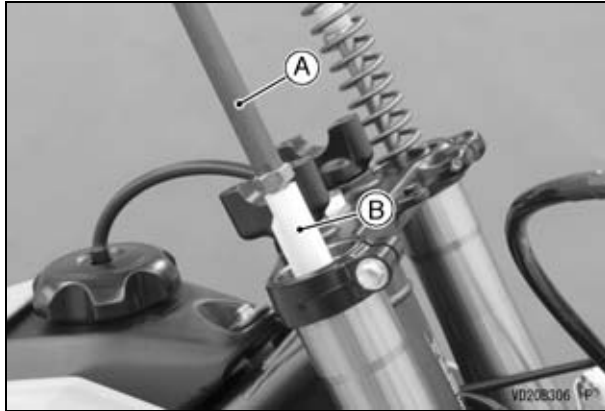

**A. Push Rod Puller (Special Tool: 57001-1298)**  
**B. Push Rod**

- Fill the fork cylinder with oil by gently moving the push rod puller up and down five times.
- Fill oil between the inner tube and outer tube by pumping the outer tube up and down five times.
- Adjust the fork oil level within the adjustable range to suit your preferences.

**Standard Fork Oil Level**

95 ±2 mm (3.74 ±0.08 in.)
---------------------------

**Adjustable Range**

75 ~ 115 mm (2.95 ~ 4.53 in.)
-------------------------------

- Remove the excess oil through the outer tube opening, using an oil level gauge (special tool: 57001-1290).

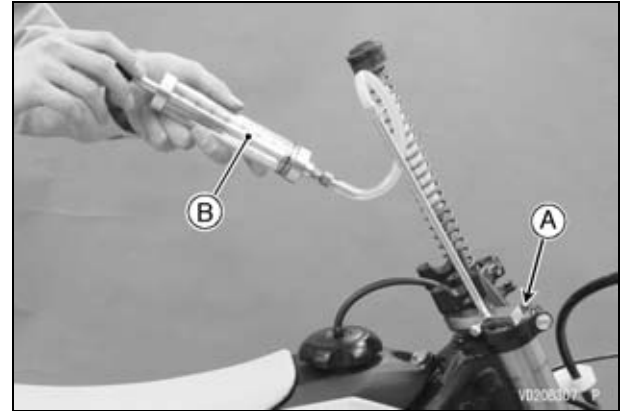

**A. Outer Tube Opening**  
**B. Oil Level Gauge (Special Tool: 57001-1290)**

- Pull up the push rod puller.
- Hold the push rod with your hand and remove the push rod puller.
- Install the fork spring and the fork spring seat on the fork spring.
- Replace both top plug O-rings with new ones.

## 116 MAINTENANCE AND ADJUSTMENT

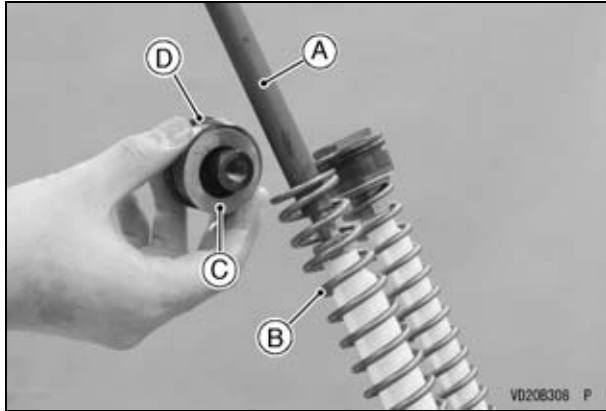

- A. Push Rod Puller (Special Tool: 57001-1298)
- B. Fork Spring
- C. Fork Spring Seat
- D. O-ring

- Check the front fork push rod nut on the bottom of the thread, and screw the front fork top plug onto the push rod.
- While holding the front fork push rod nut with a wrench, tighten it to the specified torque.

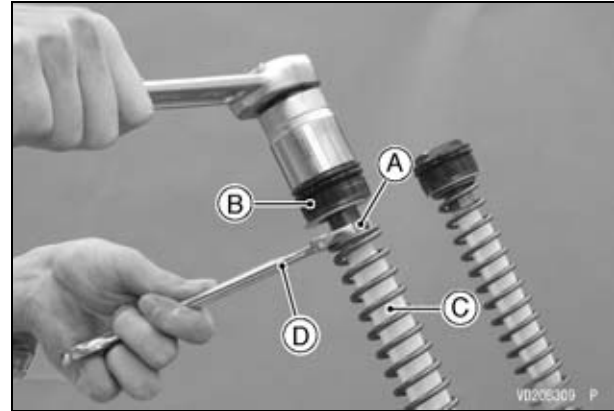

- A. Front Fork Push Rod Nut
- B. Front Fork Top Plug
- C. Push Rod
- D. Wrench

### Tightening Torque

Front Fork Push Rod Nuts:  
15 N·m (1.5 kgf·m, 11 ft·lb)

- Remove the stand and support to apply load to the vehicle.
- Tighten the front fork top plug to the specified torque.

### Tightening Torque

Front Fork Top Plugs:  
28 N·m (2.9 kgf·m, 21 ft·lb)

- Assemble the other fork tube in the same way as described above.
- Tighten the front fork clamp bolts (upper) to the specified torque.

**Tightening Torque**

Front Fork Clamp Bolts (Upper):  
20 N·m (2.0 kgf·m, 15 ft·lb)

- Install the front fork protectors so that they do not touch the front fork outer tubes.
- Install the removed parts.

*Optional Fork Springs*

Various fork springs are available to achieve suitable front fork action in accordance with the rider's weight and track condition.

Harder springs stiffen the fork action and accelerate the rebound damping.

Softer springs soften the fork action and slow down the rebound damping.

*Fork Height Adjustment*

Steering is greatly affected by the fork height. The less the fork height, the lighter the front end becomes and the greater the tendency for understeering and washout due to weight biasing. Increasing the fork height has opposite effects.

Be sure that the front tire does not touch the fender when the fork is fully compressed. Make this adjustment in 10 mm steps.

**NOTICE**

**Both fork heights should be adjusted evenly.**

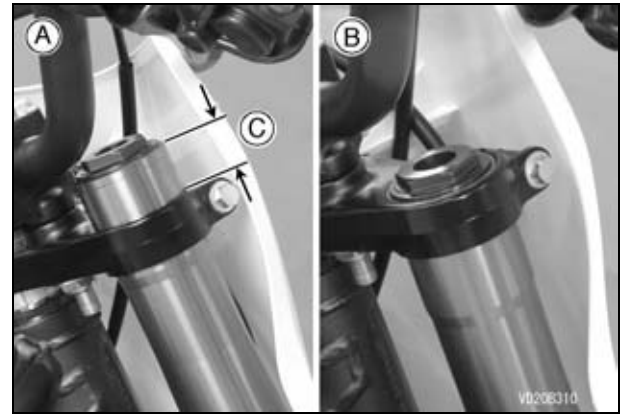

- A. KX85C
- B. KX100F
- C. Fork Height

**Standard Fork Height**

KX85C	18 mm (0.71 in.)*
KX100F	0 mm (0 in.)*

\*: Between the top end of the outer tube and upper surface of the steering stem head.

### Rear Suspension (UNI-TRAK®)

This motorcycle's rear suspension system is called "UNI-TRAK®" and consists of a rear shock absorber unit, a swingarm, two lever rods and a lever.

The operating characteristics of the UNI-TRAK® suspension are similar to those of the front fork. However, a linkage system is used to achieve progressive springing characteristics.

#### *Rear Shock Absorber Inspection*

#### **NOTICE**

**Sticking muds or dusts on the sliding surface of the rear shock absorber could damage to the oil seal, leading to an oil leak. Clean the sliding surface after each ride.**

- Pump the seat down and up by 4 or 5 times, and inspect the smooth stroke.
- If it does not smoothly or noise is found, inspect the oil leak and rear shock absorber mounting.
- Visually inspect the rear shock absorber for oil leakage.
- If necessary, replace by an authorized Kawasaki dealer.

#### *Rear Shock Absorber Adjustment*

The spring preload of the shock absorber can be adjusted or the spring can be replaced with an optional one to suit various riding conditions. In addition, the damping force can be adjusted easily, making it unnecessary to change the oil viscosity.

#### *Rebound Damping Adjustment*

To adjust the rear shock absorber rebound damping, turn the rebound damping adjuster at the bottom of the rear shock absorber with a standard tip screwdriver.



#### **A. Rebound Damping Adjuster**

If the damping feels too soft or too stiff, adjust it in accordance with the following table.

Rebound Damper Settings

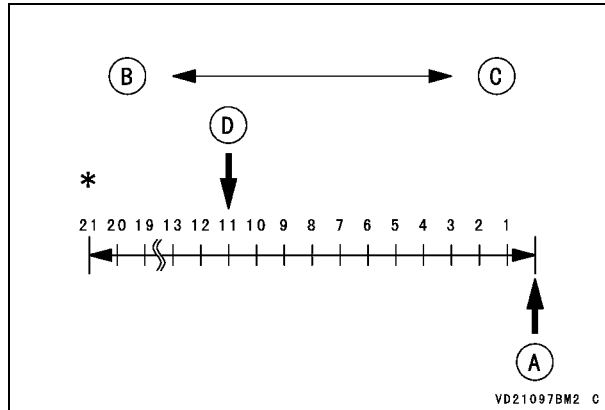

- A. Seated Position (Adjuster Turned Fully Clockwise)
- B. Softer (Counterclockwise)
- C. Harder (Clockwise)
- D. Standard Setting

\*: Number of turns counterclockwise usable range 21 clicks or more.

Standard Rebound Damper Setting

11 clicks\*

\*: Counterclockwise from the fully seated position

**NOTICE**

Do not force the rebound damping force adjuster beyond the fully seated position, or the adjusting mechanism may be damaged.

**NOTE**

○ Adjustment of the rebound damping adjuster for the rear suspension will slightly affect the compression damping force. Always make any damping adjustments in small steps and test their effects before using them in competition.

Compression Damping Adjustment (Gas Reservoir)

To adjust compression damping, turn the compression damping adjuster on the gas reservoir with a standard tip screwdriver until you feel a click.



**A. Compression Damping Adjuster**

If the damping feels too soft or too stiff, adjust it in accordance with the following table.



## 120 MAINTENANCE AND ADJUSTMENT

### Compression Damper Settings

- A. Seated Position (Adjuster Turned Fully Clockwise)
- B. Softer (Counterclockwise)
- C. Harder (Clockwise)
- D. Standard Setting (KX85C)
- E. Standard Setting (KX100F)

\*: Number of turns counterclockwise usable range 24 clicks or more.

#### Standard Compression Damper Setting

KX85C	10 clicks*
KX100F	14 clicks*

\*: Counterclockwise from the fully seated position

### **NOTICE**

**Do not force the compression damping force adjuster beyond the fully seated position, or the adjusting mechanism may be damaged.**

### **NOTE**

○ *Adjustment of the compression damping adjuster for the rear suspension will slightly affect the rebound damping force. Always make any damping adjustments in small steps and test their effects before using them in competition.*

#### *Spring Preload Adjustment*

- Remove the seat bolts.
- Remove the seat rearward.
- Remove the side cover bolts.
- Remove the side covers.

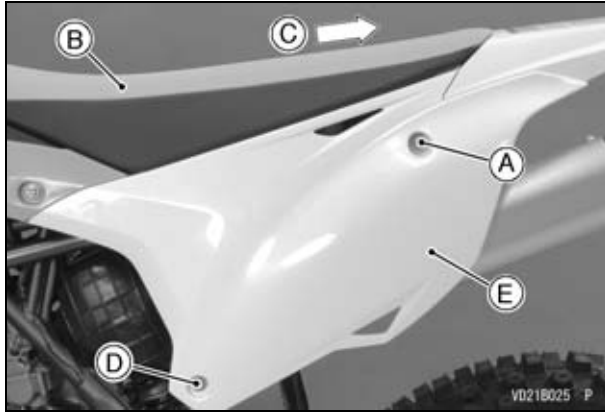

- A. Seat Bolt (Both Sides)
- B. Seat
- C. Rearward
- D. Side Cover Bolt (Both Sides)
- E. Side Cover (Both Sides)

- Remove the bolts, nuts, washers and rear fender.
- Remove the bolts and collars, and remove the rear flap.

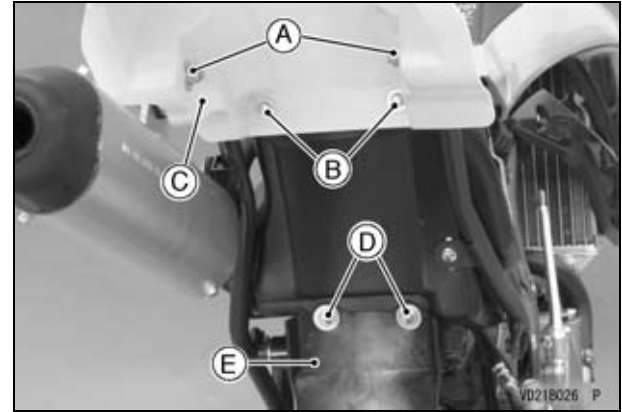

- A. Bolts, Nuts and Washers
- B. Bolts
- C. Rear Fender
- D. Bolts and Collars
- E. Rear Flap

- Remove the rear frame pipe bolts and nuts, and remove the rear frame pipe.

## 122 MAINTENANCE AND ADJUSTMENT

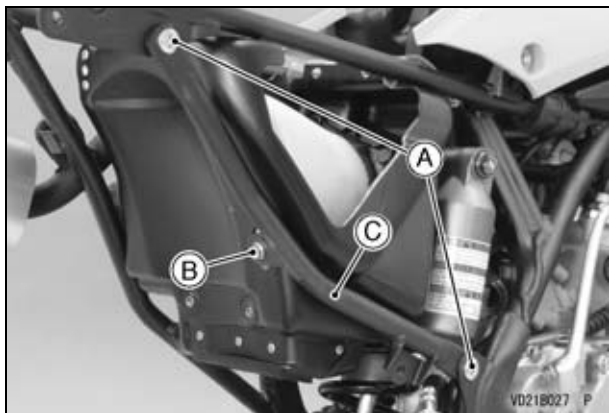

- A. Rear Frame Pipe Bolts and Nuts**
- B. Bolt**
- C. Rear Frame Pipe**

- Remove the muffler (see Exhaust System section).
- Loosen the air cleaner duct clamp screw.
- Remove the bolts and take off the air cleaner case with air cleaner duct.

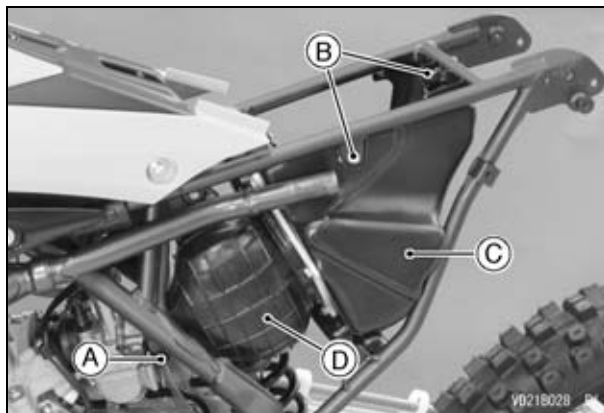

- A. Air Cleaner Duct Clamp Screw**
- B. Bolts**
- C. Air Cleaner Case**
- D. Air Cleaner Duct**

- Stuff a clean cloth into the carburetor opening to prevent dust or dirt from entering the carburetor.
- Raise the rear wheel off the ground using a jack (special tool: 57001-1238) and attachment (special tool: 57001-1608).
- Using the hook wrenches (special tools: 57001-1101, 1580), loosen the rear shock absorber spring locknut on the rear shock absorber.

## MAINTENANCE AND ADJUSTMENT 123

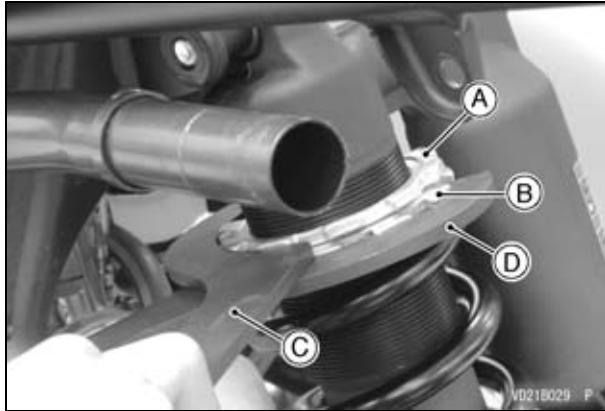

- A. Rear Shock Absorber Spring Locknut**
- B. Spring Preload Adjusting Nut**
- C. Hook Wrench R35 (Special Tool: 57001-1580)**
- D. Hook Wrench R37.5 (Special Tool: 57001-1101)**

- Using the hook wrench (special tool: 57001-1101), turn the spring preload adjusting nut as required. Turning the adjusting nut down increases the spring preload.

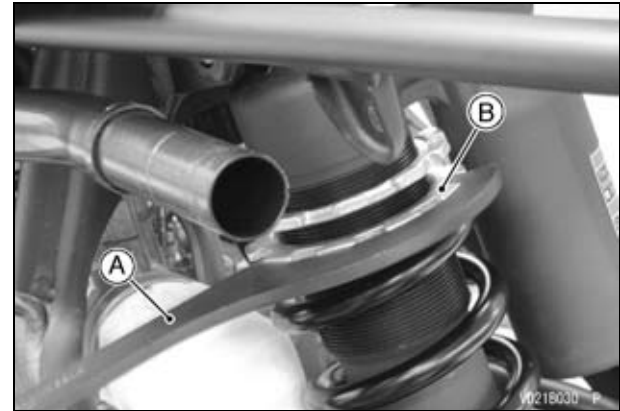

- A. Hook Wrench R37.5 (Special Tool: 57001-1101)**
- B. Spring Preload Adjusting Nut**

- The standard adjusting nut position from the center of the upper rear shock absorber pivot point is 67.5 mm (2.66 in.).
- The adjustable range is 63 ~ 81 mm (2.5 ~ 3.2 in.).

## 124 MAINTENANCE AND ADJUSTMENT

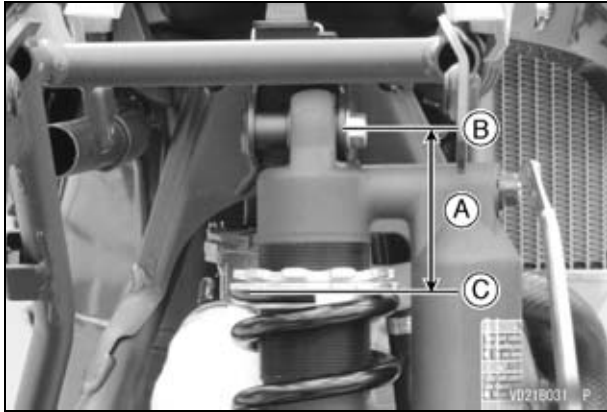

- A. Adjusting Nut Position**
- B. Center of Upper Rear Shock Absorber Pivot**
- C. Spring End**

- Tighten the rear shock absorber spring locknut.
- After making the adjustment, move the spring up and down to make sure that it is properly seated.
- Install the air cleaner case with air cleaner duct.
- Install the muffler (see Exhaust System section).
- Replace the rear frame pipe nuts with new ones.
- Install the rear frame pipe.

### Tightening Torque

Rear Frame Pipe Nuts:  
34 N·m (3.5 kgf·m, 25 ft·lb)

- Replace the rear fender mounting nuts with new ones.
- Install the removed parts.

### *Optional Rear Shock Absorber Springs*

Various rear shock absorber springs are available to achieve suitable rear shock absorber action in accordance with the rider's weight and track condition.

A harder spring stiffens the shock absorber action and accelerates the rebound damping.

A softer spring softens the shock absorber action and slows down the rebound damping.

### **⚠ WARNING**

**Improper removal or installation of the rear shock absorber spring may cause the spring and/or related parts to be ejected at high velocity. Always wear eye and face protection when working on the rear shock absorber. Removal and installation of the rear shock absorber spring should be performed by an authorized Kawasaki dealer.**

## Wheels

### Tire Air Pressure

Tire air pressure affects traction, handling, and tire life. Adjust the tire air pressure to suit track conditions and rider preference, but keep it close within the recommended range.

- To check the tire air pressure, remove the air valve cap, and make sure to tighten the cap securely after checking the tire pressure.

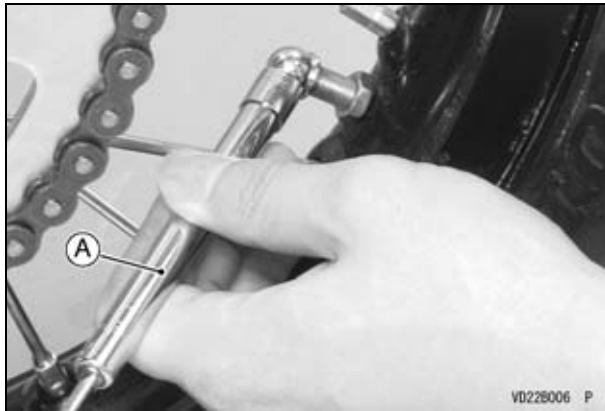

A. Tire Pressure Gauge

- Reduce the tire air pressure to increase the tire tread surface on the ground when riding on a wet, muddy, sandy or slippery track.
- Increase the tire air pressure to prevent damage or punctures (though the tires will skid more easily) when riding on a pebbly or hard track.

### Air Pressure (when cold)

Front	100 ~ 125 kPa (1.02 ~ 1.27 kgf/cm <sup>2</sup> , 14.5 ~ 18.1 psi)
Rear	100 ~ 125 kPa (1.02 ~ 1.27 kgf/cm <sup>2</sup> , 14.5 ~ 18.1 psi)

### NOTE

- *Tire air pressure should be checked when the tires are cold, before you ride the motorcycle.*

### Spokes and Rims

The spokes on both wheels must all be evenly adjusted and not be allowed to loosen. Unevenly tightened or loose spokes will cause the rim to warp, the nipples and spokes to fatigue more quickly, and the spokes to break.

## 126 MAINTENANCE AND ADJUSTMENT

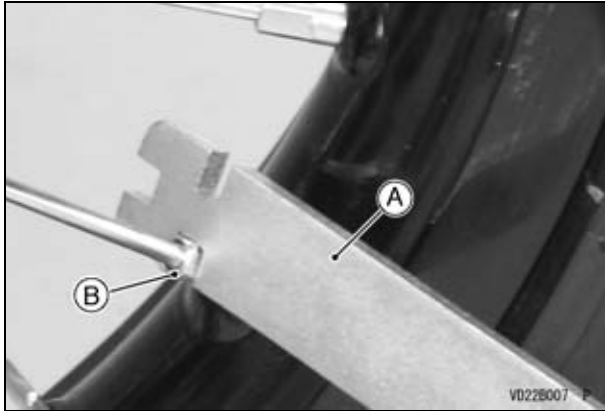

**A. Spoke Wrench**  
**B. Spoke Nipple**

- Tighten the spoke nipples to the specified torque.

### Tightening Torque

Spoke Nipples:

4.0 N·m (0.41 kgf·m, 35 in·lb)

### Bead Protector

There is a bead protector nut on the rear wheel. The bead protector nut prevents the tire and tube from slipping on the rim and damaging the valve stem. Valve stem damage may cause the tube to leak, necessitating tube replacement. In order to keep the tire and tube in position on the rim, inspect the bead protector nut before riding and tighten it if necessary. Tighten the valve stem nut finger tight only.

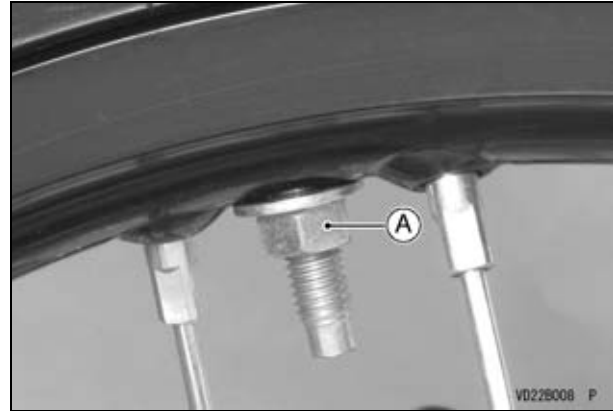

**A. Bead Protector Nut**

### Rim Runout

- Raise the rear wheel off the ground using a jack (special tool: 57001-1238) and attachment (special tool: 57001-1608).
- Set up a dial gauge on the side of the rim and rotate the wheel to measure its axial runout. The difference between the highest and lowest readings is the amount of runout.
- Set up the dial gauge on the inner circumference of the rim and rotate the wheel to measure its radial runout. The difference between the highest and lowest readings is the amount of runout.
- A certain amount of rim warpage (runout) can be corrected by recentering the rim, that is, by loosening some spokes and tightening other to change the position of certain portions of the rim. If the rim is badly bent, however, it should be replaced.

**NOTE**

○ The welding spot of the rim may show excessive runout. Disregard this when measuring rim runout.

**Rim Runout**

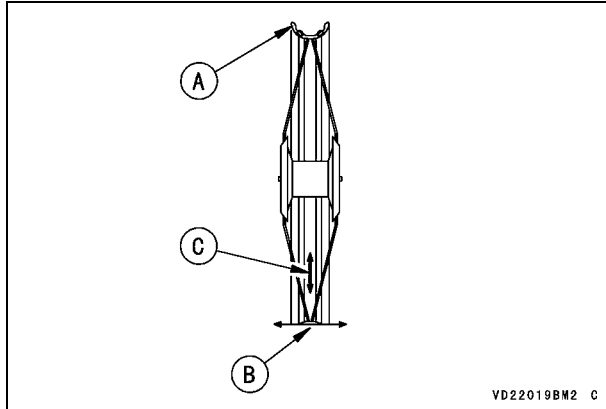

- A. Rim
- B. Axial Runout
- C. Radial Runout

**Rim Runout (with tire installed)**

Axial	Standard	*TIR 1.0 mm (0.04 in.) or less
	Service Limit	*TIR 2.0 mm (0.08 in.)
Radial	Standard	*TIR 1.0 mm (0.04 in.) or less
	Service Limit	*TIR 2.0 mm (0.08 in.)

\*: Total Indicator Reading

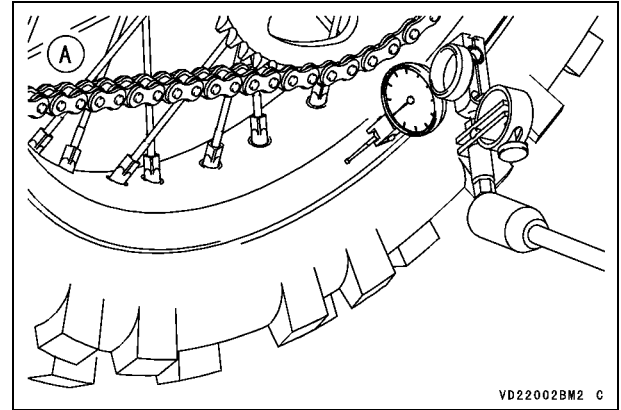

**A. Axial Rim Runout Measurement**

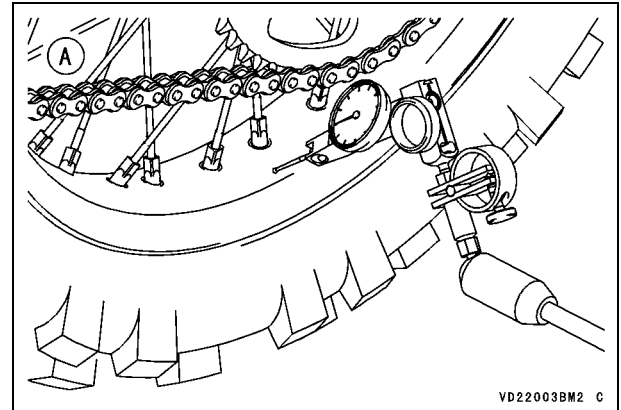

**A. Radial Rim Runout Measurement**



### Hoses Inspection

Check the brake and fuel hoses for cracks or deterioration, and the connections for looseness in accordance with the Periodic Maintenance Chart.

- Inspect the hoses and fittings for deterioration, cracks and signs of leakage by bending or twisting the hoses.
- If damaged, replace the hoses.

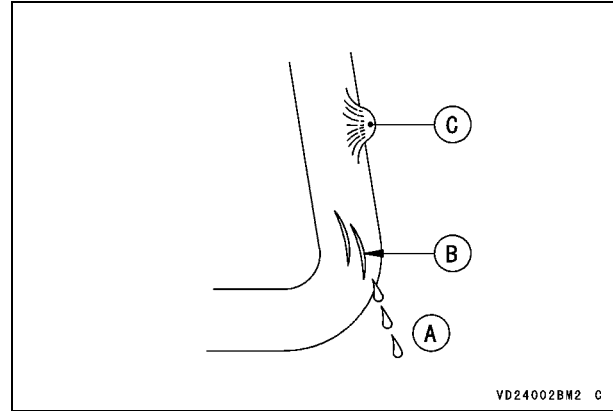

- A. Leak**
- B. Cracks**
- C. Bulges**

- Check that the hoses are securely connected and bolts are tightened correctly.

## Tightening Torques of Nuts and Bolts

### *Location of nuts and bolts*

Before the first ride of each day of operation, check the tightness of the nuts and bolts shown below. Check also that all cotter pins are in place and in good condition.

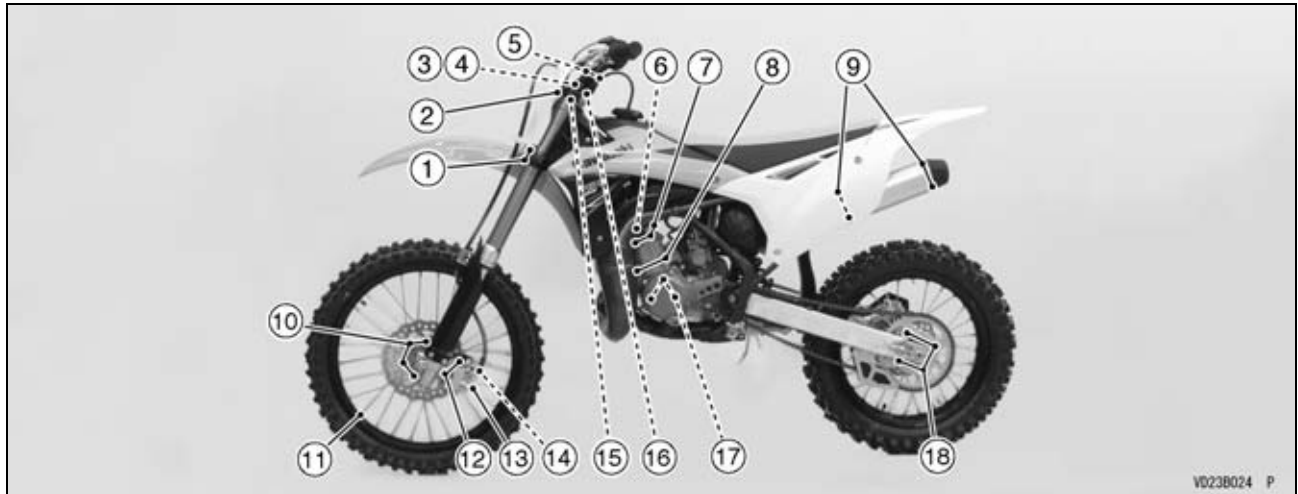

1. Front Fork Clamp Bolts (Lower) (Both Sides)
2. Front Fork Clamp Bolt (Upper) (Both Sides)
3. Front Fork Top Plug (Both Sides)
4. Air Pressure Relief Screw (Both Sides)
5. Handlebar Holder Bolts
6. Spark Plug

7. Cylinder Head Nuts
8. Cylinder Nuts
9. Muffler Body Cover Bolts
10. Front Brake Disc Mounting Bolts
11. Spoke Nipples (Front and Rear)
12. Front Caliper Mounting Bolts

13. Brake Hose Banjo Bolt (Front and Rear)
14. Bleed Valve (Front and Rear)
15. Front Fork Push Rod Nut (Both Sides)
16. Handlebar Holder Nuts
17. Starter Coil Plate Mounting Screws
18. Rear Sprocket Nuts

## 130 MAINTENANCE AND ADJUSTMENT

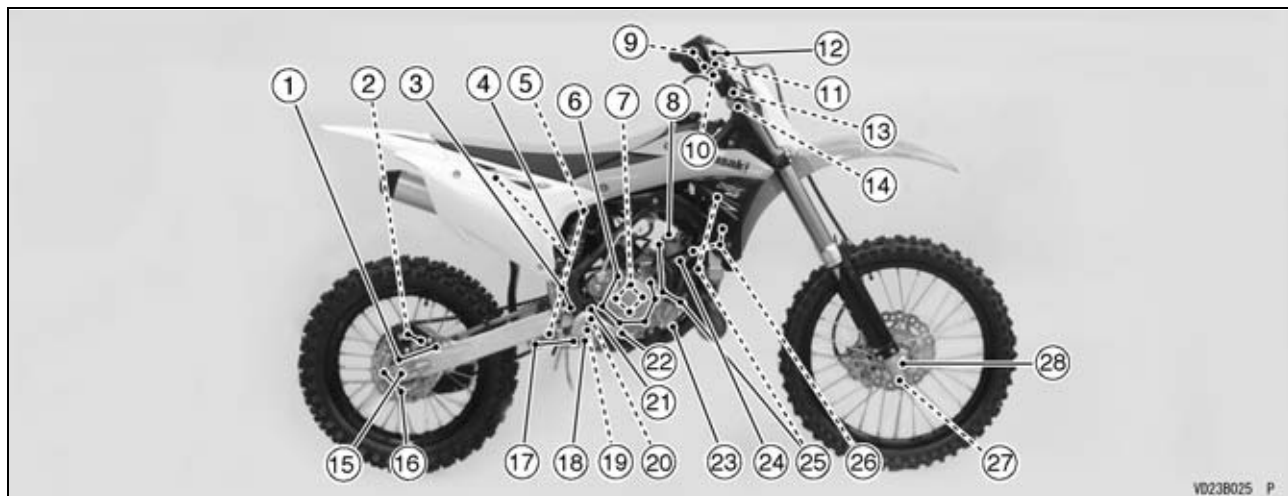

VD23B025 P

- |  |                                      |   |
|--|--------------------------------------|---|
| 1. Rear Caliper Mounting Bolts         | 11. Brake Lever Pivot Bolt           | 23. Coolant Drain Bolt (Water Pump)         |
| 2. Rear Brake Pad Pins                 | 12. Front Brake Reservoir Cap Screws | 24. Coolant Drain Bolt (Cylinder)           |
| 3. Rear Master Cylinder Mounting Bolts | 13. Steering Stem Head Nut           | 25. Water Hose Clamp Screws                 |
| 4. Rear Frame Pipe Nuts                | 14. Steering Stem Nut                | 26. Engine Bracket Mounting Nuts            |
| 5. Rear Shock Absorber Mounting Bolts  | 15. Rear Axle Nut                    | 27. Compression Valve Assembly (Both Sides) |
| 6. Clutch Cover Bolts                  | 16. Rear Brake Disc Mounting Bolts   | 28. Front Axle Nut                          |
| 7. Clutch Spring Bolts                 | 17. Tie-Rod Mounting Nuts            |   |
| 8. Air Bleeder Bolt                    | 18. Brake Pedal Bolt                 |   |
| 9. Front Master Cylinder Clamp Bolts   | 19. Rocker Arm Pivot Nut             |   |
| 10. Brake Lever Pivot Bolt Locknut     | 20. Rocker Arm Bracket Bolts         |   |
|  | 21. Swingarm Pivot Shaft Nut         |   |
|  | 22. Transmission Oil Drain Bolt      |   |

*Torque table*

Tighten all nuts and bolts to the proper torque using an accurate torque wrench. An insufficiently tightened nut or bolt may become damaged or fall out, possibly resulting in damage to the motorcycle and injury to the rider. An overtightened nut or bolt may become damaged, broken, or fall out.

G: Apply grease.

L: Apply a non-permanent locking agent.

R: Replacement Parts

S: Follow the specified tightening sequence.

Si: Apply silicone grease (ex. PBC grease).

2T: Apply 2-stroke oil.

<b>Fastener</b>	<b>N·m</b>	<b>kgf·m</b>	<b>ft·lb</b>	<b>Remarks</b>
Front Fork Clamp Bolts (Lower) (Both Sides)	20	2.0	15	
Front Fork Clamp Bolt (Upper) (Both Sides)	20	2.0	15	
Front Fork Top Plug (Both Sides)	28	2.9	21	
Air Pressure Relief Screw (Both Sides)	1.3	0.13	12 in·lb	
Handlebar Holder Bolts	25	2.5	18	2T, S
Spark Plug	25.5	2.60	18.8	
Cylinder Head Nuts	25	2.5	18	S
Cylinder Nuts	25	2.5	18	S
Muffler Body Cover Bolts	8.8	0.90	78 in·lb	L
Front Brake Disc Mounting Bolts	9.8	1.0	87 in·lb	L
Spoke Nipples (Front and Rear)	4.0	0.41	35 in·lb	
Front Caliper Mounting Bolts	25	2.5	18	
Brake Hose Banjo Bolt (Front and Rear)	25	2.5	18	
Bleed Valve (Front and Rear)	7.8	0.80	69 in·lb	

## 132 MAINTENANCE AND ADJUSTMENT

Fastener	N·m	kgf·m	ft·lb	Remarks
Front Fork Push Rod Nut (Both Sides)	15	1.5	11	
Handlebar Holder Nuts	34	3.5	25	R
Stator Coil Plate Mounting Screws	5.2	0.53	46 in·lb	
Rear Sprocket Nuts	34	3.5	25	R
Rear Caliper Mounting Bolts	25	2.5	18	
Rear Brake Pad Pins	17.2	1.75	12.7	
Rear Master Cylinder Mounting Bolts	9.8	1.0	87 in·lb	
Rear Frame Pipe Nuts	34	3.5	25	R
Rear Shock Absorber Mounting Bolts	39	4.0	29	
Clutch Cover Bolts	9.4	1.0	83 in·lb	
Clutch Spring Bolts	9.3	0.95	82 in·lb	
Air Bleeder Bolt	9.4	1.0	83 in·lb	
Front Master Cylinder Clamp Bolts	8.8	0.90	78 in·lb	S
Brake Lever Pivot Bolt Locknut	5.9	0.60	52 in·lb	
Brake Lever Pivot Bolt	5.9	0.60	52 in·lb	Si
Front Brake Reservoir Cap Screws	1.5	0.15	13 in·lb	
Steering Stem Head Nut	64	6.5	47	
Steering Stem Nut	4.9	0.50	43 in·lb	
Rear Axle Nut	78	8.0	58	R
Rear Brake Disc Mounting Bolts	9.8	1.0	87 in·lb	L
Tie-Rod Mounting Nuts	59	6.0	44	R
Brake Pedal Bolt	25	2.5	18	G

**MAINTENANCE AND ADJUSTMENT 133**

<b>Fastener</b>	<b>N·m</b>	<b>kgf·m</b>	<b>ft·lb</b>	<b>Remarks</b>
Rocker Arm Pivot Nut	83	8.5	61	R
Rocker Arm Bracket Bolts	83	8.5	61	G
Swingarm Pivot Shaft Nut	69	7.0	51	R
Transmission Oil Drain Bolt	20	2.0	15	
Coolant Drain Bolt (Water Pump)	5.2	0.53	46 in·lb	
Coolant Drain Bolt (Cylinder)	8.8	0.90	78 in·lb	
Water Hose Clamp Screws	3.0	0.31	27 in·lb	
Engine Bracket Mounting Nuts	29	3.0	21	R
Compression Valve Assembly (Both Sides)	55	5.6	41	
Front Axle Nut	78	8.0	58	R

---

### Cleaning Your Motorcycle

---

#### *General Precautions*

Frequent and proper care of your Kawasaki motorcycle will enhance its appearance, optimize overall performance, and extend its useful life. Covering your motorcycle with a high quality, breathable motorcycle cover will help protect its finish from harmful UV rays, pollutants, and reduce the amount of dust reaching its surfaces.

#### **WARNING**

**Build-up of debris or flammable material in and around the vehicle chassis, engine, and exhaust can cause mechanical problems and increase the risk of fire.**

**When operating the vehicle in conditions that allow debris or flammable material to collect in and around the vehicle, inspect the engine, electrical component and exhaust areas frequently. If debris or flammable materials have collected, park the vehicle outside and stop the engine. Allow the engine to cool, then remove any collected debris. Do not park or store the vehicle in an enclosed space prior to inspecting for build-up of debris or flammable materials.**

- Be sure the engine and exhaust are cool before washing.

- Avoid applying degreaser to seals, brake pads, and tires.
- Always use non-abrasive wax and cleaner/polisher.
- Avoid all harsh chemicals, solvents, detergents, and household cleaning products such as ammonia-based window cleaners.
- Gasoline, brake fluid, and coolant will damage the finish of painted and plastic surfaces: wash them off immediately.
- Avoid wire brushes, steel wool, and all other abrasive pads or brushes.
- Use care when washing the plastic parts as they can easily be scratched.
- Avoid using pressure washers; water can penetrate seals and electrical components and damage your motorcycle.
- Avoid spraying water in delicate areas such as in air intakes, carburetor, brake components, electrical components, muffler outlets, and fuel tank openings.

#### *Washing Your Motorcycle*

- Rinse your bike with cold water from a garden hose to remove any loose dirt.
- Mix a mild neutral detergent (designed for motorcycles or automobiles) and water in a bucket. Use a soft cloth or sponge to wash your motorcycle. If needed, use a mild degreaser to remove any oil or grease which build up.
- After washing, rinse your motorcycle thoroughly with clean water to remove any residue (residue

from the detergent can damage parts of your motorcycle).

- Use a soft cloth to dry your motorcycle. As you dry, inspect your motorcycle for chips and scratches. Do not let the water air dry as this can damage the painted surfaces.
- Start the engine and let it idle for several minutes. The heat from the engine will help dry moist areas.
- Carefully ride your motorcycle at a slow speed and apply the brakes several times. This helps the brakes dry and restores them normal operating performance.
- Lubricate the drive chain to prevent rusting.

**NOTE**

○ *After riding in an area where the roads are salted or near the ocean, immediately wash your motorcycle with cold water. Do not use warm water as it accelerates the chemical reaction of the salt. After drying, apply a corrosion protection spray on all metal and chrome surfaces to prevent corrosion.*

**Semi-gloss Finish**

To clean the semi-gloss finish;

- When washing the motorcycle, always use a mild neutral detergent and water.
- The semi-gloss finish effect may be lost when it is excessively rubbed.
- If any doubt, consult an authorized Kawasaki dealer.

***Painted Surfaces***

After washing your motorcycle, coat painted surfaces, both metal and plastic, with a commercially available motorcycle/automotive wax. Wax should be applied once every three months or as conditions require. Avoid surfaces with “satin” or “flat” finishes. Always use non-abrasive products and apply them according to the instructions on the container.

***Plastic Parts***

After washing use a soft cloth to gently dry plastic parts. When dry, treat the non-painted plastic parts with an approved plastic cleaner/polisher product.

**NOTICE**

**Plastic parts may deteriorate and break if they come in contact with chemical substances or household cleaning products such as gasoline, brake fluid, window cleaners, thread-locking agents, or other harsh chemicals. If a plastic part comes in contact with any harsh chemical substance, wash it off immediately with water and a mild neutral detergent, and then inspect for damage. Avoid using abrasive pads or brushes to clean plastic parts, as they will damage the part’s finish.**

***Chrome and Aluminum***

Chrome and uncoated aluminum parts can be treated with a chrome/aluminum polish. Coated



## 136 MAINTENANCE AND ADJUSTMENT

aluminum should be washed with a mild neutral detergent and finished with a spray polish. Aluminum wheels, both painted and unpainted can be cleaned with special non-acid based wheel spray cleaners.

### *Leather, Vinyl, and Rubber*

If your motorcycle has leather accessories, special care must be taken. Use a leather cleaner/treatment to clean and care for leather accessories. Washing leather parts with detergent and water will damage them, shortening their life.

Vinyl parts should be washed with the rest of the motorcycle, then treated with a vinyl treatment.

The sidewalls of tires and other rubber components should be treated with a rubber protectant to help prolong their useful life.

### **⚠ WARNING**

**Rubber protectants can be slippery and, if used on the tread area, cause loss of traction resulting in accident causing injury or death. Do not apply rubber protectant to any tread area.**

## Lubrication

Lubricate the areas shown in the illustrations of this section with either motor oil or regular grease, after each race and whenever the vehicle has been operated under wet or rainy conditions, especially after using a high-pressure spray washer. Before lubricating a part, clean off any rust with rust remover and wipe off any grease, oil, dirt, or grime.

### *General Lubrication*

Apply motor oil to the following pivots:

- Clutch Lever
- Front Brake Lever

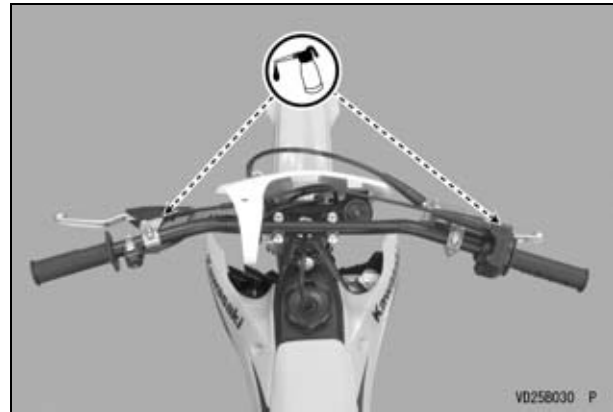

- Rear Brake Pedal
- Rear Master Cylinder Joint Pin
- Kick Pedal
- Footpeg

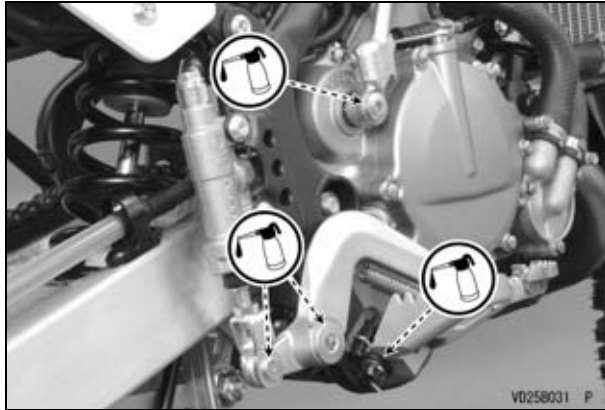

- Shift Pedal

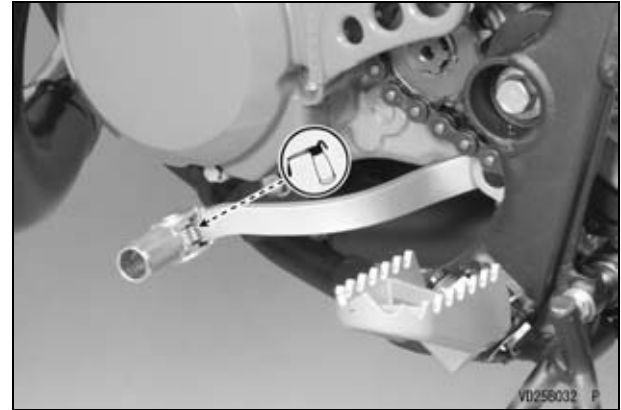

Apply an aerosol cable lubricant with a pressure lubricator on all cables:

- Clutch Cable
- Throttle Cable

## 138 MAINTENANCE AND ADJUSTMENT

### Cable Lubrication

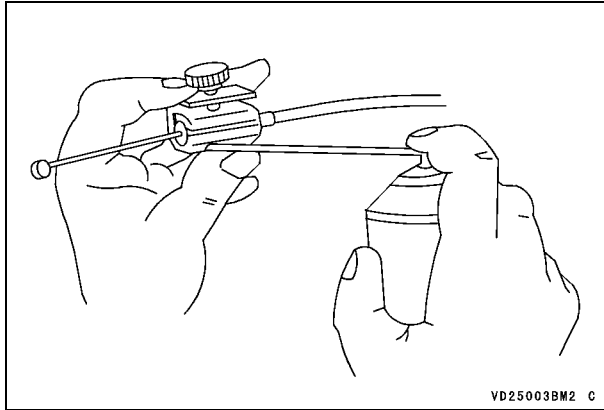

Apply grease to the following points:

- Clutch Inner Cable Upper End
- Throttle Inner Cable Upper End

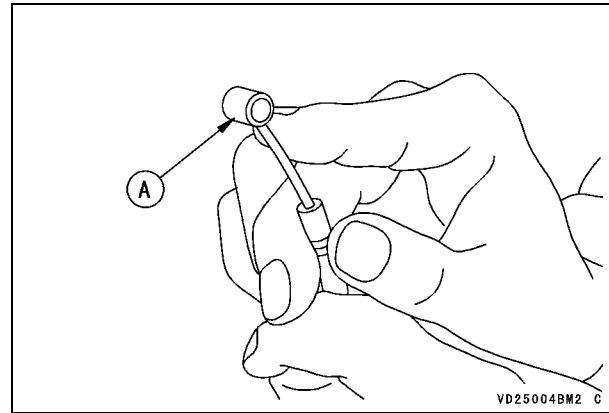

**A. Upper End**

### *Drive Chain Lubrication*

Lubrication is necessary after riding through rain or on wet roads, or any time that the chain appears dry.

Use a lubricant for drive chains. If the chain is especially dirty, clean it using a cleaner for drive chains following the instructions supplied by the chain cleaner manufacturer.

- Apply lubricant to the sides of the rollers so that it will penetrate to the rollers and bushings. Wipe off any excess lubricant.

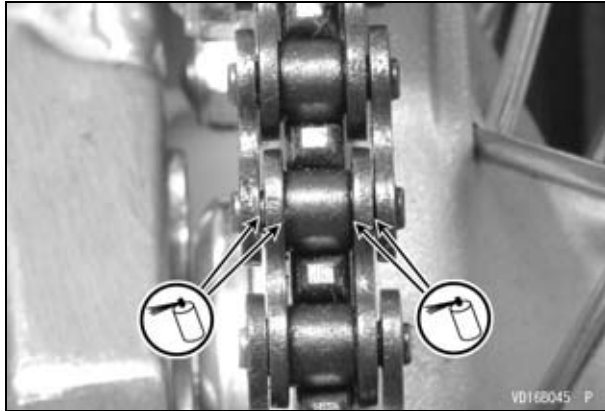

- Wipe off any lubricant that gets on the tire surface.

---

# TROUBLESHOOTING GUIDE

---

## NOTE

○ *This troubleshooting guide is not exhaustive and does not give every possible cause for each problem listed. It is meant simply as a quick guide to assist you in troubleshooting for some of the more common difficulties.*

### Starting failure or difficulties -

#### Engine does not turn over:

- Cylinder or piston seized
- Crankshaft seized
- Connecting rod small end seized
- Connecting rod big end seized
- Transmission gear or bearing seized
- Kick shaft return spring broken
- Kick ratchet gear not engaging

#### Fuel does not flow:

- No fuel in tank
- Fuel tap turned off
- Tank cap air vent obstructed
- Fuel tap clogged
- Fuel line clogged
- Float valve clogged

#### Engine flooded:

- Fuel level too high
- Float valve worn or stuck open

- Wrong starting technique (when the engine is flooded, kick with the throttle fully open to allow more air to reach the engine.)

#### Spark missing or weak:

- Spark plug dirty, broken, or gap improperly adjusted
- Spark plug cap or high-tension wiring defective
- Spark plug cap not contacting properly
- Spark plug type incorrect
- Igniter defective
- Ignition coil defective
- Ignition coil resistor defective/disconnected
- Stator damaged
- Wiring shorted or interrupted

#### Fuel/air mixture incorrect:

- Idle adjusting screw improperly adjusted
- Slow jet or air passage clogged
- Air cleaner element clogged, poorly sealed, or not installed
- Starter jet clogged

#### Compression low:

- Spark plug loose
- Cylinder head insufficiently tightened
- Cylinder nut loose
- Cylinder or piston worn
- Piston ring worn, weak, broken, or sticking
- Piston ring side clearance excessive
- Cylinder head gasket damaged

- Cylinder head warped
- Cylinder base gasket damaged
- Reed valve damaged

### Poor low-speed performance -

#### Spark weak:

- Spark plug dirty, broken, or gap improperly adjusted
- Spark plug cap or high-tension wiring defective
- Spark plug cap shorted or not contacting properly
- Spark plug type incorrect
- Igniter defective
- Ignition coil defective
- Stator damaged

#### Fuel/air mixture incorrect:

- Idle adjusting screw improperly adjusted
- Slow jet or air passage clogged
- Air cleaner element clogged, poorly sealed, or not installed
- Starter plunger stuck open
- Carburetor fuel level too high or too low
- Fuel tank air vent obstructed
- Carburetor holder loose
- Air intake duct loose

#### Compression low:

- Spark plug loose
- Cylinder head insufficiently tightened
- Cylinder nut loose
- Cylinder or piston worn
- Piston ring worn, weak, broken, or sticking

- Piston ring side clearance excessive
- Cylinder head gasket damaged
- Cylinder head warped
- Cylinder base gasket damaged
- Reed valve damaged

#### KIPS ports stuck open:

- KIPS exhaust valve stuck open (valve seized or contaminated with carbon deposits)
- KIPS exhaust valves assembled incorrectly
- Exhaust advancer spring damaged
- Exhaust valve operating rod seized
- KIPS rod seized in cylinder

#### Other:

- Igniter defective
- Transmission oil viscosity too high
- Brake dragging

### Poor or no high-speed performance -

#### Firing incorrect:

- Spark plug dirty, damaged, or gap improperly adjusted
- Spark plug cap or high-tension wiring defective
- Spark plug cap shorted or not contacting properly
- Spark plug type incorrect
- Igniter defective
- Ignition coil defective
- Stator damaged

#### Fuel/air mixture incorrect:

- Main jet clogged or wrong size
- Jet needle or needle jet worn

## 142 TROUBLESHOOTING GUIDE

- Jet needle clip in wrong position
- Carburetor fuel level too high or too low
- Air jet or air passage clogged
- Air cleaner element clogged, poorly sealed or not installed
- Starter plunger stuck open
- Fuel supply to carburetor insufficient
- Fuel contaminated with water or foreign matter
- Fuel tank air vent obstructed
- Carburetor holder loose
- Air intake duct loose
- Fuel tap clogged
- Fuel line clogged

### **Compression low:**

- Spark plug loose
- Cylinder head insufficiently tightened
- Cylinder nut loose
- Cylinder or piston worn
- Piston ring worn, weak, broken, or sticking
- Piston ring side clearance excessive
- Cylinder head gasket damaged
- Cylinder head warped
- Cylinder base gasket damaged
- Reed valve damaged

### **Improper acceleration:**

- Starter plunger stuck open
- Carburetor fuel level too high or too low
- Main jet clogged
- Throttle valve does not fully open
- Air cleaner element clogged
- Muffler clogged
- Fuel contaminated with water or foreign matter

- Cylinder exhaust port clogged
- Brake dragging
- Clutch slipping
- Engine overheating
- Transmission oil level too high
- Transmission oil viscosity too high
- Crankshaft bearing worn or damaged

### **KIPS ports stuck closed:**

- KIPS exhaust valves stuck closed (valve seized or contaminated with carbon deposits)
- KIPS exhaust valves assembled incorrectly
- KIPS ports clogged (contaminated with carbon)
- Exhaust valve operating rod seized
- KIPS rod seized in cylinder

### **Knocking:**

- Carbon built up in combustion chamber
- Fuel quality poor or type incorrect
- Spark plug type incorrect
- Igniter defective

### **Engine overheating -**

#### **Firing incorrect:**

- Spark plug dirty, broken, or gap improperly adjusted
- Spark plug type incorrect
- Igniter defective

#### **Fuel/air mixture incorrect:**

- Main jet clogged or wrong size
- Carburetor fuel level too low
- Carburetor holder loose

- Air cleaner element clogged, poorly sealed, or not installed
- Air intake duct poorly sealed

**Compression high:**

- Carbon built up in combustion chamber

**Engine overloaded:**

- Brake dragging
- Clutch slipping
- Transmission oil level too high
- Transmission oil viscosity too high

**Lubrication inadequate:**

- Transmission oil level too low
- Transmission oil quality poor or type incorrect

**Coolant inadequate:**

- Coolant level too low
- Coolant deteriorated

**Cooling system component defective:**

- Radiator clogged
- Radiator cap defective
- Water pump not rotating
- Impeller of water pump defective

**Clutch operation faulty -****Clutch slipping:**

- No clutch lever play
- Clutch cable improperly adjusted
- Clutch cable defective
- Clutch plate worn or warped
- Clutch spring broken or weak

- Clutch release mechanism defective
- Clutch hub or housing unevenly worn

**Clutch not disengaging properly:**

- Clutch lever play excessive
- Clutch plate warped or too rough
- Clutch spring tension uneven
- Transmission oil deteriorated
- Transmission oil viscosity too high
- Transmission oil level too high
- Clutch housing frozen on drive shaft
- Clutch release mechanism defective

**Gear shifting faulty -****Transmission does not go into gear; shift pedal does not return:**

- Clutch not disengaging
- Shift fork bent or seized
- Gear stuck on the shaft
- Gear positioning lever binding
- Shift return spring weak or broken
- Shift return spring pin loose
- Shift mechanism arm spring broken
- Shift mechanism arm broken
- Shift drum broken

**Transmission jumps out of gear:**

- Shift fork worn
- Gear groove worn
- Gear dogs and/or dog grooves worn
- Shift drum groove worn
- Gear positioning lever spring weak or broken



## 144 TROUBLESHOOTING GUIDE

- Shift fork pin worn
- Drive shaft, output shaft, and/or gear splines worn

### **Transmission skips gears:**

- Gear positioning lever spring weak or broken
- Shift mechanism arm spring broken

### **Engine noise abnormal -**

#### **Knocking:**

- Igniter defective
- Carbon built up in combustion chamber
- Fuel quality poor or type incorrect
- Spark plug type incorrect
- Engine overheating

#### **Piston slap:**

- Piston clearance excessive
- Cylinder or piston bent
- Connecting Rod bent
- Piston pin or piston pin bores worn

#### **Other noise:**

- Connecting rod small end clearance excessive
- Connecting rod big end clearance excessive
- Piston ring worn, broken or stuck
- Piston seized or damaged
- Cylinder head gasket leaking
- Expansion chamber leaking at cylinder
- Crankshaft runout excessive
- Engine mounts loose
- Crankshaft bearing worn
- Primary gear worn or chipped

### **Abnormal drive train noise -**

#### **Clutch noise:**

- Clutch housing/friction plate clearance excessive
- Clutch housing gear/primary gear backlash excessive
- Metal chip jammed in clutch housing gear teeth

#### **Transmission noise:**

- Crankcase bearing worn or damaged
- Transmission gear worn or chipped
- Metal chip jammed in gear teeth
- Transmission oil level or viscosity too low
- Kick ratchet gear not properly disengaging from kick gear
- Output shaft idle gear worn or chipped

#### **Drive chain noise:**

- Drive chain slack improperly adjusted
- Drive chain worn
- Rear and/or engine sprocket(s) worn
- Drive chain inefficiently lubricated
- Rear wheel misaligned

### **Frame noise abnormal -**

#### **Front fork noise:**

- Oil level or viscosity too low
- Spring weak or broken

#### **Rear shock absorber noise:**

- Shock absorber damaged

**Disc brake noise:**

- Pad installed incorrectly
- Pad surface glazed
- Brake disc warped
- Brake caliper defective
- Brake master cylinder damaged

**Other noise:**

- Bracket, nut, bolt, etc. improperly mounted or tightened

**Exhaust smoke -****Excessively white:**

- Throttle cable improperly adjusted

**Brownish:**

- Air cleaner element clogged
- Main jet too large or fallen out
- Starter plunger stuck open
- Carburetor fuel level too high

**Poor handling and/or stability -****Handlebar hard to turn:**

- Control cable incorrectly routed

- Wiring incorrect routed
- Steering stem nut too tight
- Roller bearing damaged
- Steering bearing race dented or worn
- Steering stem inadequately lubricated
- Steering stem bent
- Tire air pressure too low

**Handlebar shakes or vibrates excessively:**

- Tire worn
- Swingarm sleeve or needle bearing damaged
- Rim warped or out of balance
- Front and/or rear axle runout excessive
- Wheel bearing worn
- Handlebar holder loose
- Steering stem head nut loose

**Handlebar pulls to one side:**

- Frame bent
- Wheel misaligned
- Swingarm bent or twisted
- Swingarm pivot shaft runout excessive
- Steering maladjusted
- Steering stem bent
- Front fork leg bent
- Right/left front fork oil level uneven

## 146 TROUBLESHOOTING GUIDE

### **Shock absorption unsatisfactory (suspension too hard):**

- Front fork oil excessive
- Front fork oil viscosity too high
- Front fork leg bent
- Tire air pressure too high
- Rear shock absorber improperly adjusted

### **Shock absorption unsatisfactory (suspension too soft):**

- Front fork oil level insufficient and/or front fork leaking oil
- Front fork oil viscosity too low
- Front fork and/or rear shock absorber spring weak
- Rear shock absorber leaking gas
- Rear shock absorber improperly adjusted

### **Poor braking performance -**

- Air in the brake line
- Brake pad or disc worn
- Brake fluid leaking
- Brake disc warped
- Brake pads contaminated
- Brake fluid deteriorated
- Primary and/or secondary master cylinder cup(s) damaged
- Master cylinder scratched
- Brake maladjusted (lever or pedal play excessive)

---

# TUNING

---



---

## Carburetor

---

Tuning a carburetor is not the mysterious science many racers believe it to be. One only needs to establish a basic knowledge of the identification and function of carburetor components as well as how they work together to do the job well.

### Temperature-and altitude-related mixture adjustment

Condition*	Mixture will be	Adjustment
Cold Air	Leaner	Richer
Warm Air	Richer	Leaner
Dry Air	Leaner	Richer
Low Altitude	Standard	None
High Altitude (above 1 500 m or 4 900 ft)	Richer	Leaner

\*: at constant atmospheric pressure and humidity

The main jet size should be increased or decreased by one to five sizes and the engine tested until its power is maximum.

### *Symptoms of Improper Mixture*

If your machine exhibits one or several of the symptoms listed below, it may need carburetor

tuning. Before attempting any changes, however, make sure that everything else is in good shape and properly tuned. Check the condition of the spark plug, make sure the ignition timing is correct, service the air cleaner element and decarbonize the muffler.

If your machine has run properly on a certain track in the past and then starts running poorly with the same carburetor settings, the problem is almost certain to be elsewhere; changing the carburetor settings in such a case would probably be a waste of time.

### Symptoms when the mixture is too rich

Poor acceleration
Misfire at low engine speeds
Excessive smoke
Spark plug fouling
A "deep" exhaust noise

### Symptoms when the mixture is too lean

Pinging or rattling
Erratic acceleration
Same as when running out of fuel
High engine temperature

## 148 TUNING

With pinging or rattling, make sure that the gasoline is fresh and the octane rating sufficient. You might also try a different brand of high-octane gasoline.

### Making Adjustments

Carburetor tuning is made by replacing or adjusting the main jet, jet needle and slow jet, which regulate the fuel flow, and the air screw, which regulates the air flow.

The following chart shows the working range of each component. Note how the working ranges overlap as the throttle valve opens.

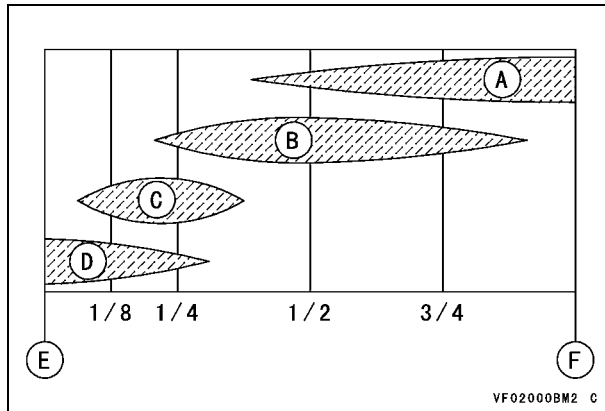

- A. Main Jet
- B. Jet Needle (Clip Position)
- C. Jet Needle (Straight Section)
- D. Air Screw and Slow Jet (Pilot Jet)
- E. Closed
- F. Full Open

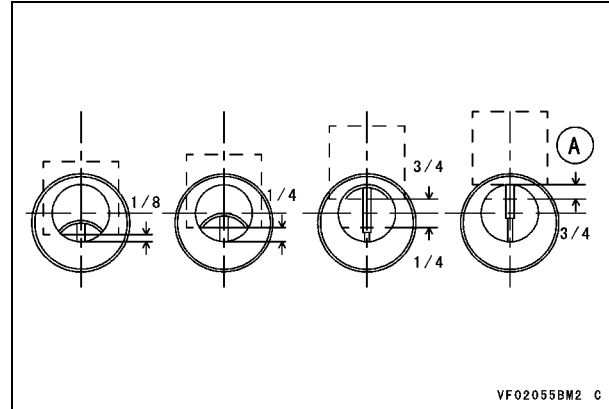

### A. Full Open

If you note a particular symptom of too rich or lean mixture in a specific operating range, use the chart to determine which components need adjusting. Use the following information to decide what changes to make.

### Main Jet

The main jet has its greatest effect in the 1/2-to-full-throttle range. The number stamped on the bottom or side of the main jet indicates the size of the hole in the jet which meters fuel. The larger the main jet number, the bigger the hole and the more fuel will flow; hence, larger numbers mean richer jetting; smaller numbers mean leaner jetting. Make main jet changes one size at a time.

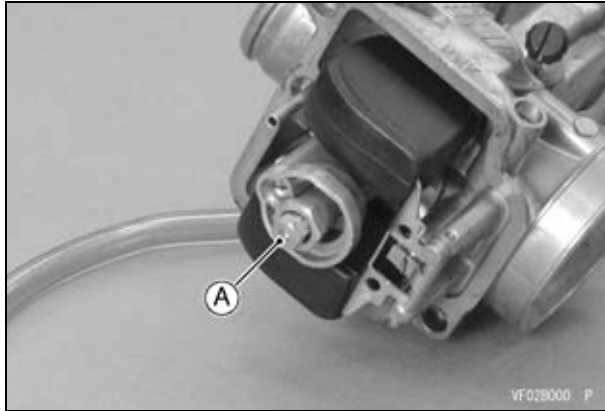

A. Main Jet

**⚠ WARNING**

Gasoline is extremely flammable and can be explosive under certain conditions. Never smoke while working on the carburetor. Make sure the area is well ventilated and free from any source of flame or sparks; this includes any appliance with a pilot light.

**Jet Needle**

The jet needle and needle jet together have their greatest effect in the 1/4-to-3/4-throttle range. The needle moves in and out of the needle jet. Since the needle is tapered, its position in the needle jet determines the amount of fuel allowed to pass through.

There are five grooves in the top of the jet needle in which a clip fits. This clip positions the jet needle in the throttle valve relative to the needle jet.

Moving the clip down has the effect of pulling the needle further out of the jet; the mixture is thereby enriched. Moving the clip up leans the mixture. Change the clip position one step at a time.

After changing the clip position of the jet needle or replacing the jet needle, check if the throttle valve operates smoothly.

**Clip Position**

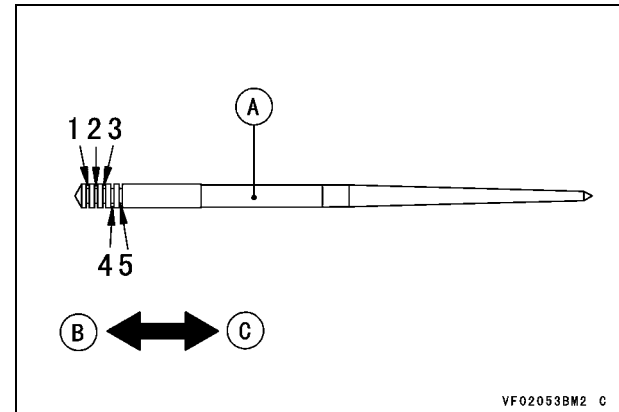

- A. Jet Needle
- B. Leaner
- C. Richer

## 150 TUNING

### Slow Jet and Air Screw

The slow jet and air screw control the mixture in the closed-to-1/8-throttle range, but have little effect between that and full throttle. To adjust the mixture in this range, the air screw can be turned to change the air flow, or the slow jet can be replaced to change the fuel flow. Start by turning the air screw. Screwing the air screw in enriches the mixture. Air screw specifications indicate the number of turns out from the lightly seated position. Make changes in 1/2-turn increments.

If turning the screw between one and two-and-a-half turns does not provide the desired results, go over to adjusting the slow jet. The slow jet has a number stamped on it, which indicates its size; the larger the jet number is, the richer the mixture. Make one-step changes of the slow jet and fine-tune with the air screw.

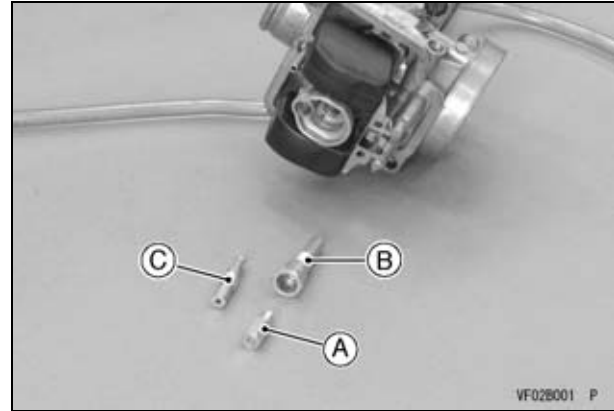

- A. Main Jet**
- B. Needle Jet**
- C. Slow Jet**

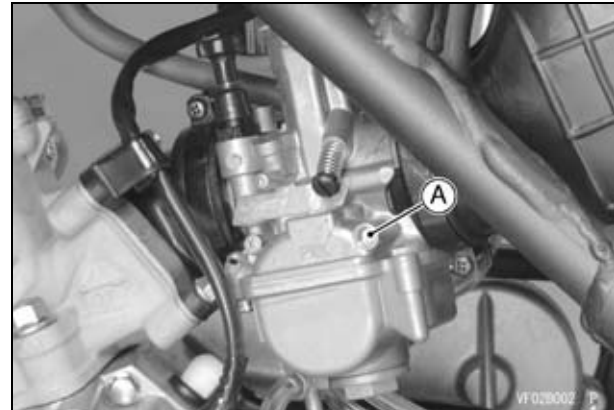

- A. Air Screw**

### Test Runs

- With all carburetor settings on standard, warm up the engine, run two or three laps of the course and examine the spark plug condition with varying throttle openings.

### Fuel/Air Mixture Adjustment

Spark Plug Insulator Condition	Mixture
Dry and a light tan color	Correct
Whitish	Too lean
Wet and sooty	Too rich

- If the spark plug insulator is whitish, the fuel/air mixture is too lean. Increase the main jet size by one step.
- If the spark plug insulator is wet, the fuel/air mixture is too rich. Reduce the main jet size by one step.
- Tune the carburetor so that the engine delivers satisfactory power at all throttle openings.

### NOTE

- *If the fuel/air mixture is too lean, the engine tends to overheat and may seize up. On the other hand, if the fuel/air mixture is too rich, the spark plug gets wet, which causes misfiring. The richness of the mixture varies depending on atmospheric conditions (pressure, humidity, and temperature). Adjust the carburetor taking these conditions into consideration.*

### Altitude and Temperature Correction Factors

### NOTE

- *For the following recommendations to be applicable, you must use the standard settings as a base. Do not change any of the settings until you have determined which are necessary. All specifications are based on the use of the specified fuel and oil.*



# 152 TUNING

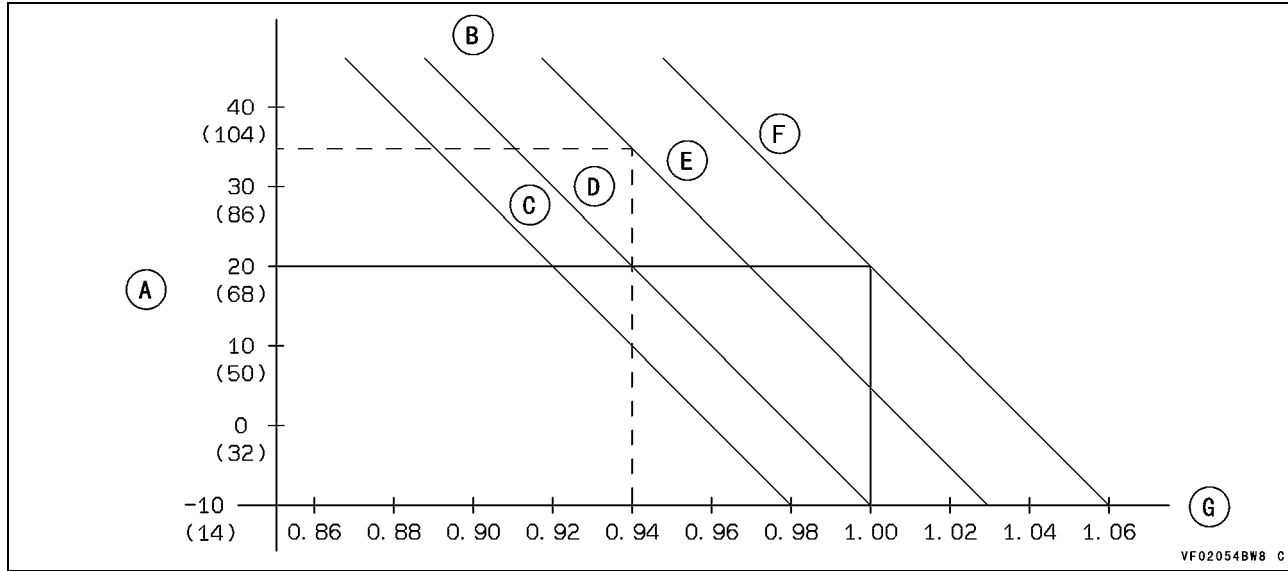

VF02054BW8 C

- A. Temperature °C (°F)
- B. Altitude
- C. 3 000 m (9 600 ft)
- D. 2 000 m (6 400 ft)
- E. 1 000 m (3 200 ft)
- F. Sea Level
- G. Correction Factor

**Correction Factor Applied to the Jet Needle and Air Screw**

Correction Factor	1.06 or above	1.06 – 1.02	1.02 – 0.98	0.98 – 0.94	0.94 or below
Jet Needle Setting	lower clip one position	same			raise clip one position
Air Screw Opening	one turn in	1/2 turn in	same	1/2 turn out	one turn out

**Standard Carburetor Settings**

Throttle Valve Cutaway	#3.5
Air Screw	KX85C: 1 1/2 turns out KX100F: 1 7/8 turns out
Slow Jet	#38
Jet Needle	KX85C: NRJC KX100F: NRKC
Jet Needle Clip Position	3rd groove
Main Jet	#140

- Determine the altitude and temperature correction factor.  
EXAMPLE: At 1 000 m (3 200 ft) altitude and an air temperature of 35°C (95°F), the correction factor is 0.94 (see dotted line in the appropriate chart on the previous page).
- Select the correct slow jet and main jet.  
EXAMPLE: For a correction factor of 0.94, multiply the jet size by that number.

**Slow Jet Size Selection for a Correction factor of 0.94**

$\#38 \times 0.94 = \#36$
---------------------------

**Main Jet Size Selection for a Correction factor of 0.94**

$\#140 \times 0.94 = \#132$
-----------------------------

- Change the jet needle clip position and air screw opening according to the appropriate chart on the previous page.  
EXAMPLE: For a correction factor of 0.94, raise the needle clip one position and turn out the air screw one extra turn.

**Jet Needle Clip and Air Screw Setting for a Correction Factor of 0.94**

Jet Needle Clip	3rd groove from top – 1 groove = 2nd groove
Air Screw	KX85C: 1 1/2 turns out + 1 turn out = 2 1/2 turns out KX100F: 1 7/8 turns out + 1 turn out = 2 7/8 turns out

---

### Suspension

---

#### *Introduction*

No area of machine adjustment is more critical than proper suspension tuning. An improperly tuned suspension will keep even the best rider from attaining the full benefit of his machine's ability. Match the suspension to the rider and the course conditions.

WHILE TUNING THE SUSPENSION, KEEP THE FOLLOWING IMPORTANT POINTS IN MIND:

- If the machine is new, "break-in" the suspension with at least one hour of riding before making any setting evaluations or changes.
  - The three major factors which must be considered in suspension tuning are RIDER WEIGHT, RIDER ABILITY, and TRACK CONDITIONS. Additional influences include the RIDER'S STYLE and POSITIONING on the machine.
  - Before changing the suspension settings, test changing your riding posture or position to check whether it is the cause of the problem or not.
  - It is a wise practice to adjust the suspension to suit the rider's strong points. If you are fast in the corners, adjust the suspension to allow fast cornering.
  - Make setting changes in small increments. A little bit goes a long way, and a setting is easily over adjusted.
- The front and rear suspension should always be balanced; when the one is changed, the other one might need to be changed similarly.
  - When evaluating suspension performance, the rider must make every effort to ride consistently and to recognize the effects of his input. Such things as changes in rider position and increasing fatigue may lead to incorrect judgments about necessary adjustments.
  - When the proper settings have been determined for a particular track, they should be written down for reference when returning to the same track.
  - Lubricate the bearings in the swingarm and UNI-TRAK® linkage after break-in and after every 5 races to prevent friction from affecting suspension performance.

#### *Front Fork*

##### **Front Fork Oil Level -**

The fork oil level in the fork tube is adjustable. A change in the fork oil level will not affect the spring force much at the top of fork travel, but it will have a great effect at the bottom of it.

- When the oil level is increased, the air spring becomes more progressive, and the front fork action feels "harder" in the later stage of fork travel, near the bottom.
- When the oil level is decreased, the air spring becomes less progressive, and the front fork action does not feel as "hard" in the later stage of fork travel.

### Fork Oil Level Effect on Fork Stroke

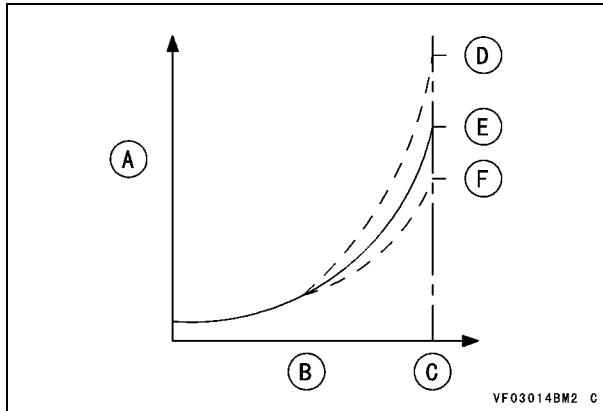

- A.** Weight
- B.** Fork Stroke
- C.** EX: 300 mm (11.8 in.)
- D.** Increase Level
- E.** Standard Oil Level
- F.** Decrease Level

Changing the fork oil level works effectively at the end of fork travel. If fork bottoming is experienced, raise the fork oil level. This will change the secondary spring rate.

#### Fork Oil Level Adjustment -

- Adjust the fork oil level (see Front Suspension section).

### Troubleshooting Improper Settings

Listed below are some symptoms of improper suspension settings and the most likely means of correcting them. The proper settings can be achieved by applying the information given in this chapter in a scientific, methodical manner. This does not mean, however, that you must be a scientist or trained technician to succeed. Simply take time to think about the changes you believe are necessary, check them against the symptoms and cures described here, make the changes in small increments, and take note of the changes and their effects.

#### Front Fork Improper Adjustment Symptoms -

##### *Too Hard*

#### **Spring too stiff:**

- Compression damping improperly adjusted.
- Spring too hard
- Fork oil level too high
- Fork air pressure high

##### *Too Soft*

#### **The front fork dives excessively during braking and deceleration:**

- Fork oil level too low
- Springs too soft
- Fork oil deteriorated
- Compression damping improperly adjusted.

## 156 TUNING

### Rear shock absorber improper adjustment symptoms -

#### *Too Hard*

#### **Suspension too stiff:**

- Compression damping too high
- Spring too hard
- Rebound damping too high
- Spring preload too hard

#### *Too Soft*

#### **Bottoming occurs on landing after a high jump (otherwise OK):**

- Spring preload too soft or compression damping too soft
- Spring too soft
- Shock absorber oil deteriorated

#### *Determining the Proper Settings*

#### **Standard Settings**

From the factory, the machine is set up for a medium-weight rider with intermediate riding ability. Hence, if the actual rider weighs considerably more or less, or if his riding experience and ability are

much above or below the intermediate level, it is likely that a few basic suspension adjustments will be necessary.

#### *Basic Readjustment of the Suspension*

#### **Suspension Tuning According to Ground Surface**

Smooth Terrain	Softer Spring
Rough Terrain	Harder Spring

#### **Suspension Tuning According to Riding Experience**

Beginner	Softer Spring with Greater Rebound Damping
Experienced Rider	Harder Spring

#### **Suspension Tuning According to Rider Weight**

Heavy Rider	Harder Spring
Light Rider	Softer Spring

### Suspension Tuning According the Type of Course

Many Corners	Lower the front end slightly [Increase the amount of fork tube protrusion above the steering stem head by 5 mm (0.2 in.)]. This accelerates steering and enhances turning ability.
Fast Course	Raise the front end slightly [Decrease the amount of fork tube protrusion above the steering stem head by 5 mm (0.2 in.)]. This slows down steering and enhances stability at high speed.
Deep Dips or Sandy Ground	Raise the front end slightly to gain stability.

Begin the actual on-track testing and evaluation after making these preliminary adjustments.

Bear in mind the following points when readjusting the suspension.

- Always make changes in small steps.
- The rider must be consistent in evaluating suspension performance.
- A change in the front suspension might require one in the rear suspension, and vice versa.

### Front and Rear Suspension Compatibility Inspection

Use this procedure to determine if the suspension is balanced reasonably well.

- Hold the motorcycle upright (remove the side stand).
- While standing next to the machine, lightly pull the brake lever, place one foot on the footpeg closest to you, and push down hard. If the motorcycle stays level as the suspension is compressed, the spring rates are well balanced.
- Sit astride the motorcycle, take a riding posture and check that the machine is in a horizontal position. If one end drops noticeably more than the other, the front and rear are not compatible and must be readjusted to achieve a better balance.



A. Push Down

## 158 TUNING

Although this is one of the most effective adjustment procedures, suspension settings may vary depending on the conditions at the track and the rider's preferences.

### *Front and Rear Suspension Troubleshooting*

#### **Front End Surges Downhill or During Acceleration Out of Corner -**

The front suspension is too soft.

- Increase the compression damping.
- Increase the fork oil level.
- Use a harder spring.

#### **Front End “Knives” or Oversteers in Turns (Tends to Turn Inward) -**

The front suspension is too soft.

- Increase the compression damping.
- Increase the fork oil level.

#### **NOTE**

○ *Heavier or expert riders may need a harder spring.*

#### **Front End Pushes or “Washes Out” in Turns (Front Wheel Tends to Push Outward Rather than “Bite” in a Turn) -**

The front suspension is too stiff.

- Decrease the compression damping.
- Release some air from the fork tubes.
- Decrease the fork oil level.
- Use a softer spring.

#### **NOTE**

○ *Lighter or less experienced riders may need a softer spring.*

#### **Front End Does Not Respond to Small Bumps in Sweeping Turns -**

The front suspension is too hard.

- Decrease the compression damping.
- Decrease the fork oil level.
- Use a softer spring.

#### **Rear End “Kicks” When Braking on Bumps -**

The rear shock absorber rebound damping may be too low.

- Increase the rebound damping.

#### **Rear Tire Does Not “Hook Up” Out of Corners (Lack of Traction Coming Out of Turns) -**

The rear shock absorber may be too stiff.

- Decrease the rear shock absorber spring preload.
- Decrease the compression damping.
- Use a softer spring (lightweight rider only).

#### **Front and Rear Ends Bottom Off After a High-speed Jump (harsh bottoming occurs once or twice per lap) -**

The front suspension is too soft.

- Increase the fork oil level.
- Use a harder spring.

The rear suspension is too soft.

- Increase the rear shock absorber spring preload or use a harder spring.
- Increase the rear shock absorber compression damping or use a harder spring.

### NOTE

- *Check the front and rear suspension compatibility after making any adjustment.*

### Rear End Feels Soft on Bumps-

- Increase the spring preload up to maximum.
- Increase the rear shock absorber compression damping.

### Rear End Bottoms After 3 or 4 Successive Jumps -

- Decrease the rebound damping.

### NOTE

- *The rear shock absorber behavior on this machine may mislead some riders.*
- *The rear shock absorber bottoms (due to full stroke) when the spring and damping are overcome by the total weight of the machine and rider.*
- *A bottoming sensation (even though the machine is actually not bottoming) may be caused by machine weight and the inability of the rider to overcome an overly stiff spring or excessive damping.*

- *Observe the rear end jumps and try lowering the spring preload and damping if it does not approach bottoming.*



## 160 TUNING

---

### Gearing

---

#### *Selection of the Secondary Reduction Ratio (Rear Sprocket)*

#### **Rear Sprocket Selection According to Course Conditions**

Fast Course	Small Sprocket
Many Corners or Hills	Large Sprocket
Sandy or Soft Ground	

- If the course has long straight portions, the secondary reduction ratio should be reduced so that the machine speed can be increased.
- If then the course has many corners or uphill or is wet, the secondary reduction ratio should be increased so that gear shifting and acceleration are smooth.
- Since the speed must be changed depending on the ground condition on the day of the race, be sure to run through the circuit prior to a race and tune the machine accordingly.
- If there is a long straight portion of the course on which the machine can be run at maximum speed, the machine should be set so that the maximum speed is developed toward the end of the straight course, but care should be taken not to over-rev the engine.

- Since it is difficult to set the machine so it is best suited for all portions of the circuit, determine which circuit portions will have the greatest effect on lap time, and tune the machine to these portions. Confirm your settings by recording lap times after each change. In this way the machine will deliver best performance for the entire circuit.

---

## Special Care According to Track Conditions

---

- In dry, dusty conditions (such a volcanic ash or fine powdery dust), special care must be given to keeping the air cleaner element clean.
  - When riding on wet, heavy clay, mud adheres to the tires and other parts of the vehicle. The mud can add significantly to the weight of the vehicle and therefore reduce performance. Take care to remove built-up mud from the tires and chassis after each ride, before drying occurs.
  - The engine works hardest in muddy conditions and the radiator can become clogged with mud. Take care not to overheat the engine in these conditions. The engine also works very hard when riding in deep sand.
- In muddy or sandy conditions, increase chain slack as the chain and sprockets will be packed with mud or sand, which reduces chain slack.
  - Check chain and sprocket wear frequently when riding in mud or sand, since wear is increased in these conditions.
  - Sticking muds or dusts on the front fork inner tube and rear shock absorber rod could damage to the oil seal, leading to an oil leak. Clean the sticking muds or dusts from the front fork inner tube and rear shock absorber rod after each ride.
  - In very dusty conditions, as the air cleaner collects dust, the mixture becomes richer and it may be advisable to apply slightly leaner jetting (main jet).

# OPTIONAL PARTS

Optional part	KX85C	KX100F
<b>Carburetor</b>		
Main Jet	135	
	138	
	**140	
	142	
	145	
Slow Jet	150	
	35	
	**38	
	40	
	42	

Jet Needle		
Richer	NRJA	NRJA
	NRJB	NRJB
↕	**NRJC	NRJC
	NRJD	NRJD
Leaner	NRJE	NRJE
Richer	NRKA	NRKA
	NRKB	NRKB
↕	NRKC	**NRKC
	NRKD	NRKD
Leaner	NRKE	NRKE

**NOTE**

○ NRJ\* is 0.5 clip position richer than NRK\*.

## OPTIONAL PARTS 163

Optional part	KX85C	KX100F
Engine Sprocket	13T	**13T
	**14T	14T
Rear Sprocket	48T	49T
	49T	50T
	**50T	**51T
	51T	52T
	52T	53T
<b>Suspension Spring [N/mm (kgf/mm)]</b>		
Front	K = 2.65 (0.27)	
	K = 2.75 (0.28)	
	**K = 2.84 (0.29)	
	K = 2.94 (0.30)	
Rear	K = 43 (4.4)	
	K = 45 (4.6)	
	**K = 47 (4.8)	
	K = 49 (5.0)	

Optional part	KX85C	KX100F
<b>Disc Plate</b>		
Front	No Holes (For Wet Conditions)	
Rear	No Holes (For Wet Conditions)	
<b>Wheel (Without Tire)</b>		
Front	17 × 1.40	19 × 1.40
Rear	14 × 1.60	16 × 1.85

\*\* : Standard equipment

# PRE-RACE CHECKS AND AFTER-RACE MAINTENANCE

## Pre-Race Checks -

- Front axle nut torque
- Front fork clamp bolt torque
- Handlebar holder bolt torque
- Throttle case cover screw tightness
- Throttle grip operation
- Front and rear brake hose installation
- Front and rear brake fluid level
- Front and rear brake disc and caliper installation
- Front and rear brake function
- Fuel tank installation
- All control cable routings
- Engine mounting nut torque
- Engine bracket mounting nut torque
- Engine sprocket installation
- Shift pedal bolt torque
- Transmission oil level
- Carburetor clamp screw torque
- Carburetor top cap torque
- Tie-rod mounting nut torque
- Rocker arm pivot nut torque
- Rocker arm bracket bolt torque
- Rear shock absorber mounting bolt torque
- Swingarm pivot shaft nut torque
- Rear axle nut torque
- Rear sprocket nut torque
- Rear brake pedal operation
- Seat installation
- Front and rear wheel spoke nipple torque

- Front and rear tire air pressure
- Front fork air pressure
- Drive chain slack
- Coolant level
- Oil applied to air cleaner element

## Maintenance After the First Race -

- Clean the air cleaner element.
- Adjust the drive chain slack.
- Torque the rear sprocket nuts.
- Torque the spoke nipples.
- Check the front and rear tire air pressure.
- Torque the front and rear axle nuts.
- Torque the swingarm pivot shaft nut.
- Torque the muffler and expansion chamber bolts.
- Tighten the front and rear fender bolts.
- Tighten the fuel tank and seat bolts.
- Check the front and rear brake function.
- Check the steering play.
- Fill the fuel tank with fuel.
- Check the coolant level.

## Maintenance After Riding on a Dusty Course -

- If dirt or dust gets into the engine, cylinder, piston and crankshaft bearings will be damaged. After riding, inspect the crankshaft big end. If the crankshaft big end is worn past the service limit, replace the crankshaft with a new one.
- Clean the sliding surface of the front fork and rear shock absorber.

### **Maintenance After Riding in the Rain or on a Muddy Course -**

- Clean the sliding surface of the front fork and rear shock absorber.
- Apply grease to swingarm and rear suspension pivots.
- Inspect the drive chain and rear sprocket for wear.
- Clean the air cleaner element.
- Check the cylinder and crankshaft big end.
- Grease the throttle grip and control cables.

### **Suggested Spare Parts -**

- Front and rear wheels
- Shift pedal and brake pedal
- Brake lever, clutch lever, and holders
- Throttle and clutch cables
- Handlebars
- Front and rear fenders, side covers, and number plate
- Radiator, radiator shroud, and water hoses
- Throttle grip assembly

- Carburetor jets
- Air cleaner element
- Muffler, and related parts
- Chain case
- Front fork springs (for suspension adjustment)
- Rear shock absorber springs (for suspension adjustment)
- Rear and engine sprockets with bolts/nuts and cir-clips
- Electrical parts
- Spark plugs
- Clutch assembly and friction plates
- Gaskets
- Front and rear tires (various compounds and tread patterns for different conditions)
- Front fork assembly
- Piston and piston ring
- Tire wraps, bolts, nuts, screws, O-rings, washers, snap rings, wire, adhesive tape, vinyl tape (or duct tape), and #400 to #600 emery cloth

# STORAGE

## Before Storage

When the motorcycle is to be stored for any length of time, it should be prepared for storage as follows.

- Clean the entire vehicle thoroughly.
- Run the engine for about five minutes to warm the oil, then stop it and drain the transmission oil.

### WARNING

**Transmission oil is a toxic substance. Dispose of used oil properly. Contact your local authorities for approved disposal methods or possible recycling.**

- Install the oil drain bolt and fill in fresh transmission oil.
- Empty the fuel from the fuel tank by the pump or siphon.
- Empty the fuel system by running the engine at idle speed until the engine stalls (If left in for a long time, the fuel will break down and could clog the fuel system).

### WARNING

**Gasoline is extremely flammable and can be explosive under certain conditions, creating the potential for serious burns. Always stop the engine and never smoke while handling fuel. Make sure the area is well ventilated and free from any source of flame or sparks; this includes any appliance with a pilot light. Make sure the engine is cold before working. Wipe any fuel off the engine before starting it. Gasoline is a toxic substance. Dispose of gasoline properly. Contact your local authorities for approved disposal methods.**

- Remove the spark plug and spray fogging oil directly into the cylinder. Kick the engine over slowly a few times to coat the cylinder wall. Install the spark plug.
- Lubricate the drive chain and all the cables.
- Spray oil on all unpainted metal surfaces to prevent rusting. Avoid getting oil on rubber parts and on the brakes.
- Lift the motorcycle on a box or stand so that both wheels are raised off the ground. (If this cannot be done, put boards under the front and rear wheels to keep dampness away from the tire rubber.)
- Tie a plastic bag over the muffler to prevent moisture from entering.
- Cover the motorcycle to keep dust and dirt away from it.

---

**After Storage**

---

- Remove the plastic bag from the muffler.
- Make sure the spark plug is tight.

**NOTE**

- *Fit the plug cap securely onto the spark plug, and pull the cap lightly to make sure that it is properly installed.*

- Fill the fuel tank with fuel.
- Check all the points listed in the Daily Pre-Ride Checks section.
- Perform a lubrication procedure in the Lubrication section.





---

## ENVIRONMENTAL PROTECTION

---

Kawasaki subscribes to the guidelines of Tread Lightly! a program dedicated to protecting the great outdoors through education and fostering responsible enjoyment of public lands. When using your Kawasaki motorcycle, please follow these Tread Lightly! guidelines:

### **Tread Lightly!**

**T**ravel responsibly on designated roads and trails or in permitted areas.

**R**espect the rights of others including private property owners and all recreational trail users, campers and others to allow them to enjoy their recreational activities undisturbed.

**E**ducate yourself by obtaining travel maps and regulations from public agencies, planning for your trip, taking recreation skills classes, and knowing how to use and operate your equipment safely.

**A**void sensitive areas such as meadows, lakeshores, wetlands and streams, unless on designated routes. This protects wildlife habitat and sensitive soils from damage.

**D**o your part by leaving the area better than you found it, properly disposing of waste, minimizing the use of fire, avoiding the spread of invasive species, restoring degraded areas, and joining a local enthusiast organization.

Properly discard used tires, oils, other vehicle components, or the entire vehicle that you might dispose of in the future. Consult your authorized Kawasaki dealer or local environmental waste agency for their proper disposal procedure.

# WIRING DIAGRAM

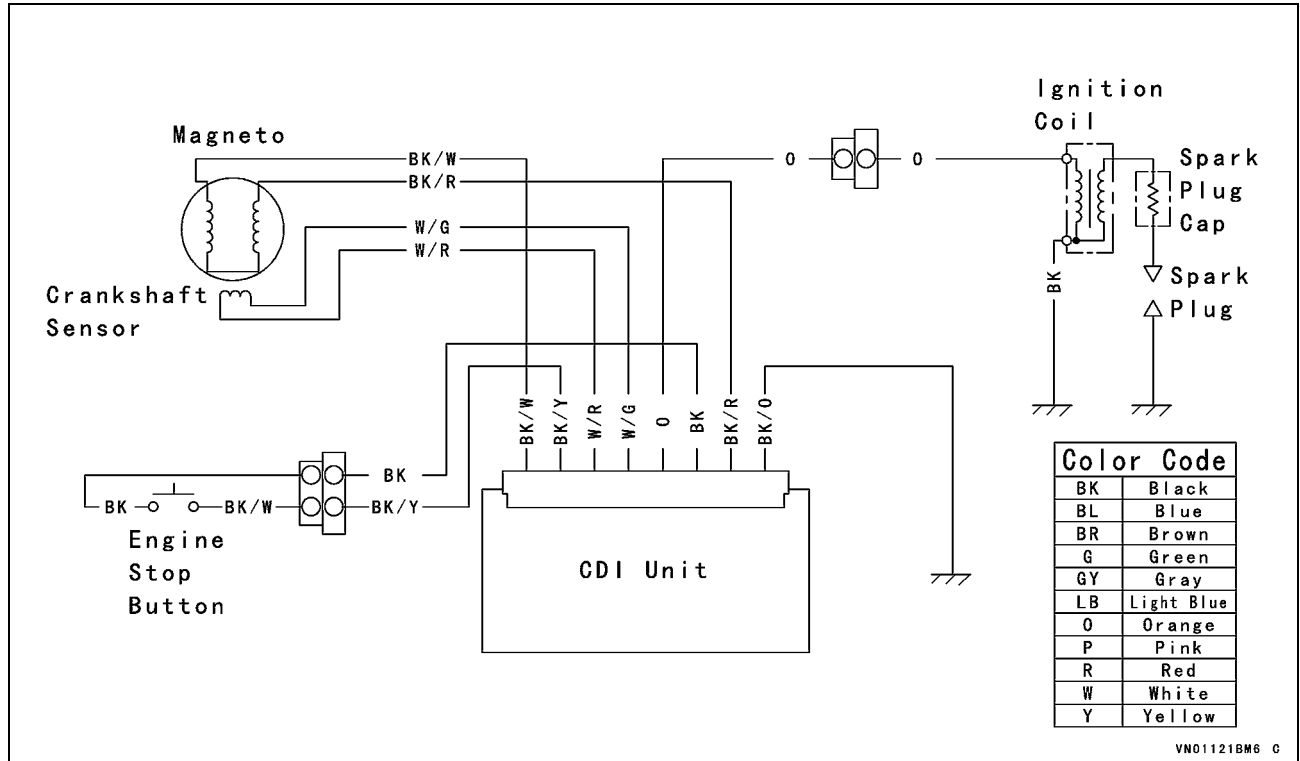

# KX85CF/KX100FF

