

YAMAHA

NOT FOR SALE

OWNER'S MANUAL
YZF1000RJJ

433 28199-20

YZF1000RJ**OWNER'S MANUAL****©1996 by Yamaha Motor Co., Ltd.****1st Edition, March 1996**

**All rights reserved. Any reprinting or
unauthorized use without the written
permission of Yamaha Motor Co., Ltd.
is expressly prohibited.
Printed in Japan.**

INTRODUCTION

Congratulations on your purchase of the Yamaha YZF1000R. This model is the result of Yamaha's vast experience in the production of fine sporting, touring, and pacesetting racing machines. It represents the high degree of craftsmanship and reliability that have made Yamaha a leader in these fields.

This manual will give you an understanding of the operation, inspection, and basic maintenance of this motorcycle. If you have any questions about the operation or maintenance of your motorcycle, please consult a Yamaha dealer.

IMPORTANT MANUAL INFORMATION

EAA10500

Particularly important information is distinguished in this manual by the following notations:



The Safety Alert Symbol means ATTENTION! BECOME ALERT! YOUR SAFETY IS INVOLVED!

WARNING

Failure to follow WARNING instructions could result in severe injury or death to the motorcycle operator, a bystander or a person inspecting or repairing the motorcycle.

CAUTION

A CAUTION indicates special precautions that must be taken to avoid damage to the motorcycle.

NOTE:

A NOTE provides key information to make procedures easier or clearer.

EUU00000

NOTE: _____

This manual should be considered a permanent part of this motorcycle and should remain with it even if the motorcycle is subsequently sold.

EUU13800

NOTE: _____

Yamaha continually seeks advancements in product design and quality. Therefore, while this manual contains the most current product information available at the time of printing, there may be minor discrepancies between your motorcycle and this manual. If there is any question concerning this manual, please consult your Yamaha dealer.

⚠ WARNING

**PLEASE READ THIS MANUAL CAREFULLY
AND COMPLETELY BEFORE OPERATING
THIS MOTORCYCLE.**

CONTENTS

SAFETY AND GENERAL INFORMATION	1
CONTROL FUNCTIONS	2
PRE-OPERATION CHECKS	3
OPERATION AND IMPORTANT RIDING POINTS	4
PERIODIC MAINTENANCE AND MINOR REPAIR	5
CLEANING AND STORAGE	6
SPECIFICATIONS	7
NOISE REGULATION (FOR Australia)	8

SAFETY AND GENERAL INFORMATION

SAFETY INFORMATION	1-1
LOCATION OF THE IMPORTANT LABELS.....	1-9
DESCRIPTION	1-11
MOTORCYCLE IDENTIFICATION.....	1-13
Identification numbers record.....	1-13
Key identification number.....	1-13
Vehicle identification number	1-14
Model label.....	1-14

⚠ SAFETY INFORMATION

1 TWO-WHEELED MOTORCYCLES ARE SINGLE TRACK VEHICLES. THEIR SAFE USE AND OPERATION ARE DEPENDENT UPON THE USE OF PROPER RIDING TECHNIQUES AS WELL AS THE EXPERTISE OF THE OPERATOR.

EVERY OPERATOR SHOULD KNOW THE FOLLOWING REQUIREMENTS BEFORE RIDING.

HE OR SHE SHOULD:

1. OBTAIN THOROUGH INSTRUCTIONS FROM A COMPETENT SOURCE ON ALL ASPECTS OF MOTORCYCLE OPERATION.
2. OBSERVE THE WARNINGS AND MAINTENANCE REQUIREMENTS IN THE OWNER'S MANUAL.
3. OBTAIN QUALIFIED TRAINING IN SAFE AND PROPER RIDING TECHNIQUES.
4. OBTAIN PROFESSIONAL TECHNICAL SERVICE AS INDICATED BY THE OWNER'S MANUAL AND/OR WHEN MADE NECESSARY BY MECHANICAL CONDITIONS.

SAFE RIDING

1. Always make pre-operation checks. Careful checks may help prevent an accident.
2. This motorcycle is designed to carry the operator and a passenger.

- 3. The failure of motorists to detect and recognize motorcycles in traffic is the predominating cause of automobile/motorcycle accidents. Many accidents have been caused by an automobile driver who did not see the motorcycle. Making yourself conspicuous appears to be very effective in reducing the chance of this type of accident.**

Therefore:

- a. Wear a brightly colored jacket.**
 - b. Use extra caution when you approach and pass through intersections, since intersections are the most likely places for motorcycle accidents.**
 - c. Ride where other motorists can see you. Avoid riding in another motorist's "blind spot".**
- 4. Many accidents involve inexperienced operators. In fact, many operators who have been involved in accidents do not even have a current motorcycle license.**
- a. Make sure you are qualified. Also, only lend your motorcycle to experienced operators.**
 - b. Know your skills and limits. Staying within your limits may help you to avoid an accident.**
 - c. We recommend that you practice riding your motorcycle where there is no traffic until you have become thoroughly familiar with your motorcycle and all of its controls.**

5. Many motorcycle accidents have been caused by motorcycle operator errors. A typical error made by the operator is veering wide on a turn due to **EXCESSIVE SPEED** or undercornering (insufficient lean angle for the speed).
 - a. Always obey the speed limits and never travel faster than warranted by road and traffic conditions.
 - b. Always signal before turning or changing lanes. Make sure other motorists see you.
6. The operator's and passenger's posture are important for proper control.
 - a. The operator should keep both hands on the handlebars and both feet on the operator footrests during operation to maintain control of the motorcycle.
 - b. The passenger should always hold on to the operator, or the seat strap or grab bar if the motorcycle is so equipped, with both hands and keep both feet on the passenger footrests.
 - c. Never carry a passenger unless he or she can firmly place both feet on the passenger footrests.
7. Never ride under the influence of alcohol or drugs.
8. This motorcycle is designed for on-road use only. It is not suitable for off-road use.

PROTECTIVE APPAREL

The majority of fatalities from motorcycle accidents are the result of head injuries. The use of a safety helmet is the single most critical factor in the prevention or reduction of head injuries.

1. Always wear an approved helmet.
2. Wear a face shield or goggles. Wind on your unprotected eyes could contribute to an impairment of vision which could delay seeing a hazard.
3. The use of heavy boots, jacket, trousers, gloves, etc. is effective in preventing or reducing abrasions or lacerations.
4. Never wear loose fitting clothing. It could catch on the control levers, footrests, or wheels and cause injury or accident.
5. Never touch the engine or exhaust system during or after operation. They become very hot and can cause burns. Always wear protective clothing that covers your legs, ankles, and feet.
6. A passenger should also observe the above precautions.

MODIFICATION

Modifications made to the motorcycle not approved by Yamaha, or the removal of original equipment, may render your motorcycle unsafe for use and may cause severe personal injury. Modifications may also make your motorcycle illegal to use.

LOADING AND ACCESSORIES

Adding accessories or cargo to your motorcycle can adversely affect stability and handling if the weight distribution of the machine is changed. To avoid the possibility of an accident, extreme caution should be used if adding cargo or accessories to your motorcycle. Use extra care if riding a motorcycle which has added cargo or accessories. Here are some general guidelines to follow if loading cargo or adding accessories to your motorcycle:

LOADING

The total weight of the operator, passenger, accessories and cargo must not exceed the maximum load limit of 196 kg.

When loading within these weight limits, keep the following in mind:

1. Cargo and accessory weight should be kept as low and close to the motorcycle as possible. Be sure to distribute the weight as evenly as possible on both sides of the machine to minimize imbalance or instability.
2. Shifting weights can create a sudden imbalance. Make sure that accessories and cargo are securely attached to the motorcycle before riding. Recheck accessory mounts and cargo restraints frequently.

3. Never attach any large or heavy items to the handlebars, front forks, or front fender. These items, including such cargo as sleeping bags, duffle bags, or tents, can create unstable handling or slow steering response.

ACCESSORIES

Genuine Yamaha accessories have been specifically designed for use on this motorcycle. Since Yamaha cannot test all other accessories which may be available, you must personally be responsible for the proper selection, installation and use of non-Yamaha accessories. You should use extreme caution when selecting and installing any accessories.

Keep in mind these guidelines for mounting accessories in addition to those provided under "LOADING".

1. Never install accessories or carry cargo that would impair the performance of your motorcycle. Carefully inspect the accessory before using it to make sure it does not in any way reduce ground clearance or cornering clearance, limit suspension travel, steering travel or control operation, or obscure lights or reflectors.
 - a. Accessories fitted to the handlebar or the front fork area can create instability due to improper weight distribution or aerodynamic changes. If accessories are added to the handlebar or front fork area, they must be as lightweight as possible and should be kept to a minimum.

- b. Bulky or large accessories may seriously affect the stability of the motorcycle due to aerodynamic effects. Wind may attempt to lift the motorcycle, or the motorcycle may become unstable in cross winds. These accessories may also cause instability when being passed by or passing large vehicles.
 - c. Certain accessories can displace the operator from his or her normal riding position. This improper position limits the freedom of movement of the operator and may limit control ability. Therefore such accessories are not recommended.
2. Caution must be used if adding electrical accessories. If these accessories exceed the capacity of the motorcycle's electrical system, an electric failure could result, which could cause a dangerous loss of lights or engine power.

GASOLINE AND EXHAUST GAS

1. **GASOLINE IS HIGHLY FLAMMABLE:**
 - a. Always turn off the engine when refueling.
 - b. Take care not to spill any gasoline on the engine or exhaust pipe(s)/muffler(s) when refueling.
 - c. Never refuel while smoking or in the vicinity of an open flame.
2. Never start the engine or let it run for any length of time in a closed area. The exhaust fumes are poisonous and may cause loss of consciousness and death within a short time. Always operate your motorcycle in an area that has adequate ventilation.
3. Always turn off the engine before leaving the motorcycle unattended and remove the ignition key. When parking the motorcycle, note the following:

- a. The engine and exhaust pipe(s)/muffler(s) may be hot. Park the motorcycle in a place where pedestrians or children are not likely to touch these hot areas.
 - b. Do not park the motorcycle on a slope or soft ground; the motorcycle may fall over.
 - c. Do not park the motorcycle near a flammable source, e.g. a kerosene heater, or near an open flame. The motorcycle could catch fire.
4. When transporting the motorcycle in another vehicle, be sure it is kept upright. If it should lean over, gasoline may leak out of the carburetor or fuel tank.
 5. If you should swallow any gasoline, inhale a lot of gasoline vapor, or allow gasoline to get in your eye(s), see your doctor immediately. If any gasoline spills on your skin or clothing, immediately wash it off with soap and water and change your clothes.

LOCATION OF THE IMPORTANT LABELS

Please read the following labels carefully before operating this motorcycle.

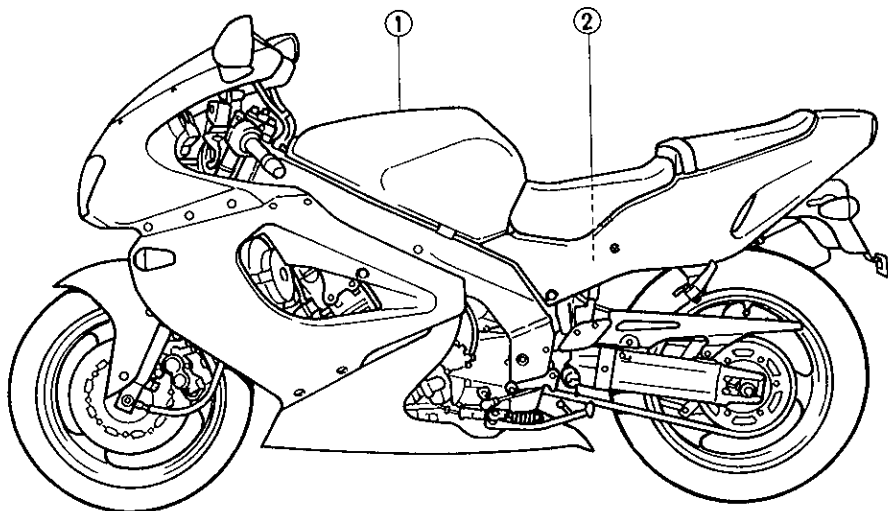
1

①

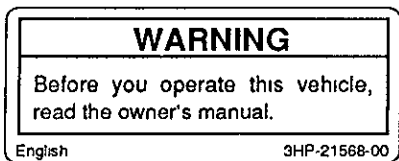

②

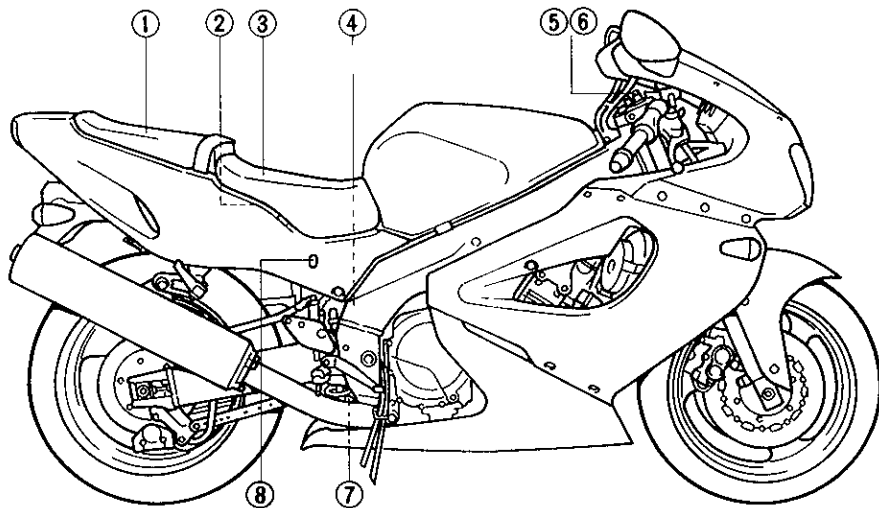

DESCRIPTION

- 1 Passenger seat
- 2 Coolant reservoir tank
- 3 Rider seat
- 4 Rear shock absorber spring preload adjusting ring
- 5 Front fork spring preload adjuster
- 6 Front fork rebound damping adjusting screw
- 7 Rear shock absorber rebound damping adjuster
- 8 Rear brake fluid level check window

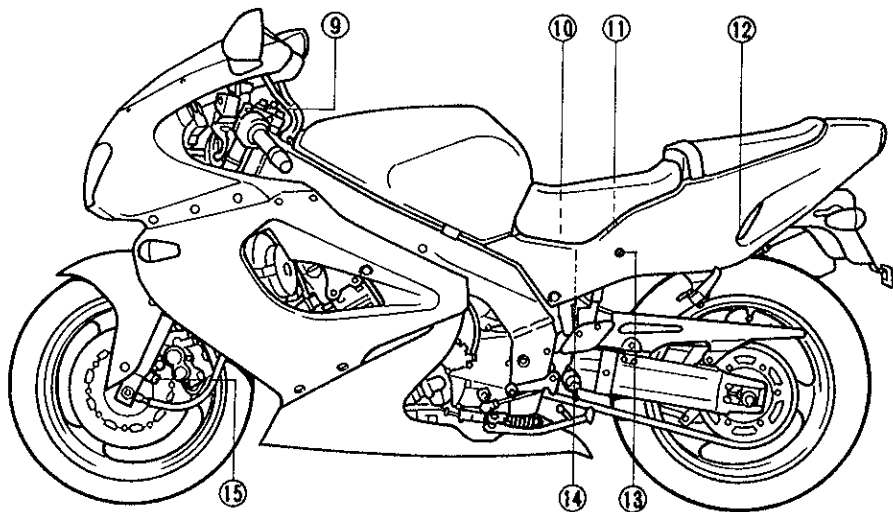

- 9 Starter "↖" "↗"
- 10. Fuse box
- 11. Helmet holder
- 12 Rider seat lock
- 13 Rear shock absorber compression damping adjusting screw
- 14. Main fuse
- 15. Front fork compression damping adjusting screw

MOTORCYCLE IDENTIFICATION

EAA61800

1 Identification numbers record

Record the key identification number, vehicle identification number and model label information in the spaces provided for assistance when ordering spare parts from a Yamaha dealer or for reference in case the vehicle is stolen.

1. KEY IDENTIFICATION NUMBER:

2. VEHICLE IDENTIFICATION NUMBER:

3. MODEL LABEL INFORMATION:

<input type="radio"/>
<input checked="" type="radio"/>

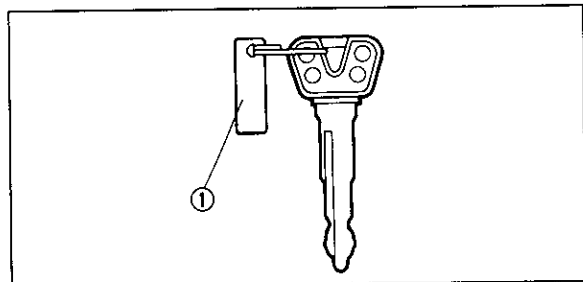
Key identification number

1 Key identification number

The key identification number is stamped on the key tag. Record this number in the space provided and use it for reference when obtaining a new key.

Vehicle identification number

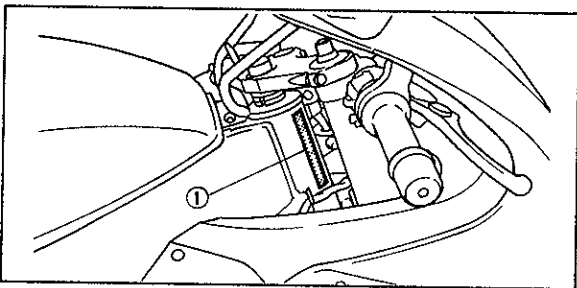

1. Vehicle identification number

The vehicle identification number is stamped into the steering head pipe.

EUU00400

NOTE:

The vehicle identification number is used to identify your motorcycle and may be used to register your motorcycle with the licensing authority in your state.

Model label

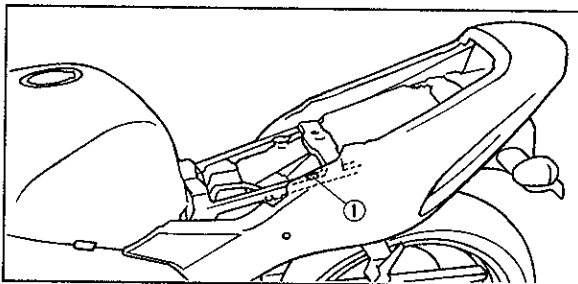

1 Model label

The model label is affixed to the frame. Record the information on this label in the space provided. This information will be needed to order spare parts from your Yamaha dealer.

CONTROL FUNCTIONS

Main switch	2-1	Rear brake pedal.....	2-15
Indicator lights	2-3	Fuel tank cap.....	2-16
Oil level indicator circuit check.....	2-5	Steering lock.....	2-17
Fuel indicator circuit check	2-7	Rider and passenger seat removal... 2-18	
Speedometer.....	2-8	Helmet holder.....	2-19
Tachometer	2-8	Storage compartment.....	2-20
Diagnosis device.....	2-9	Front fork adjustment	2-21
Engine temperature gauge.....	2-10	Rear shock absorber	2-23
Handlebar switches	2-11	Rear shock absorber adjustment.....	2-24
Starter “ ” “\”	2-13	Luggage strap holders.....	2-26
Clutch lever.....	2-13	Sidestand	2-27
Shift pedal	2-14	Sidestand/clutch switch operation	
Front brake lever.....	2-15	check	2-28

Main switch

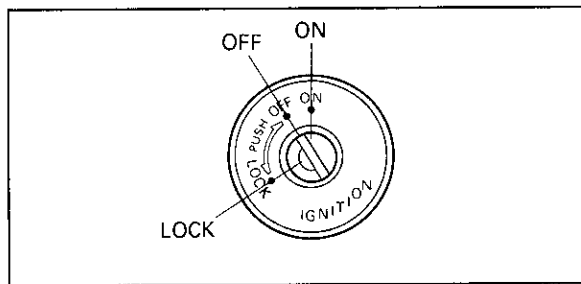

2

The main switch controls the ignition and lighting systems. Its operation is described below.

EAB04800

ON:

All electrical circuits are switched on, and the headlight, meter light, taillight, and front position lights come on. The engine can be started. The key cannot be removed in this position.

EAB00600

OFF:

All electrical circuits are switched off. The key can be removed in this position.

EAB00701

LOCK:

The steering is locked in this position, and all electrical circuits are switched off. The key can be removed in this position. Refer to "Steering lock" (page 2-17) for operation instructions.

EUU00700

NOTE: _____
Always turn the main switch to "OFF" or
"LOCK" and remove the key when the mo-
torcycle is unattended.

Indicator lights

2

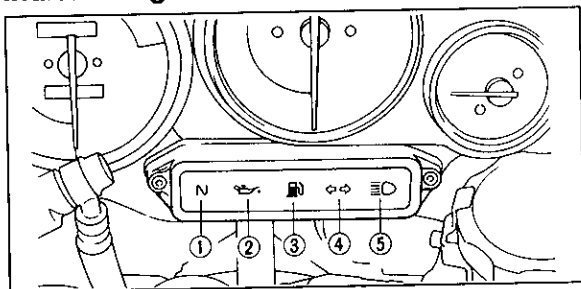

- 1 Neutral indicator light "N"
- 2 Oil level indicator light "🛢️"
- 3 Fuel indicator light "🛢️"
- 4 Turn indicator lights "◊◊"
- 5 High beam indicator light "⏏"

EAB10102

Turn indicator light "◊◊"

This indicator flashes when the turn switch is moved to the left or right.

EAB13100

Neutral indicator light "N"

This indicator comes on when the transmission is in neutral.

EAB13200

High beam indicator light "⏏"

This indicator comes on when the headlight high beam is used.

EAB13401

Oil level indicator light "🛢️"

This indicator comes on when the oil level is low. This light circuit can be checked by the following procedure.

EUU30000

CAUTION: _____

Do not run the motorcycle until you know it has sufficient engine oil.

EUU20900

NOTE: _____

Even if the oil is filled to the specified level, the indicator light may flicker when riding on a slope or during sudden acceleration or deceleration, but this is not abnormal.

Oil level indicator circuit check

2

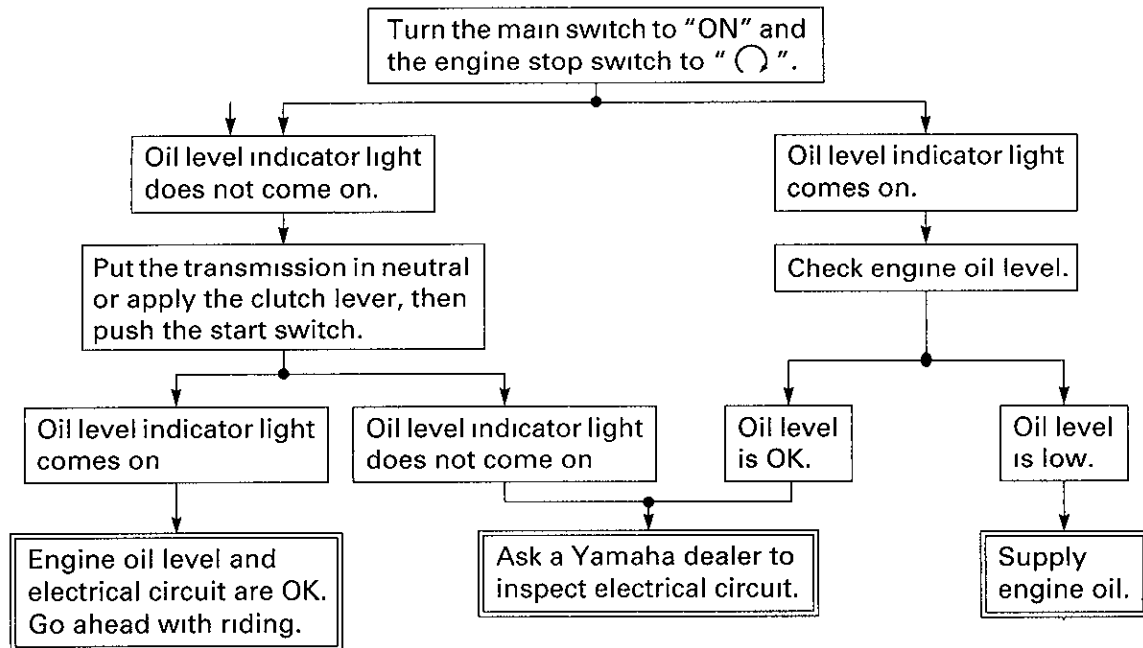

EAB12901

Fuel indicator light “”

When the fuel level drops below approximately 4.5 L, this light will come on. When this light comes on, fill the tank at the first opportunity.

Fuel indicator circuit check

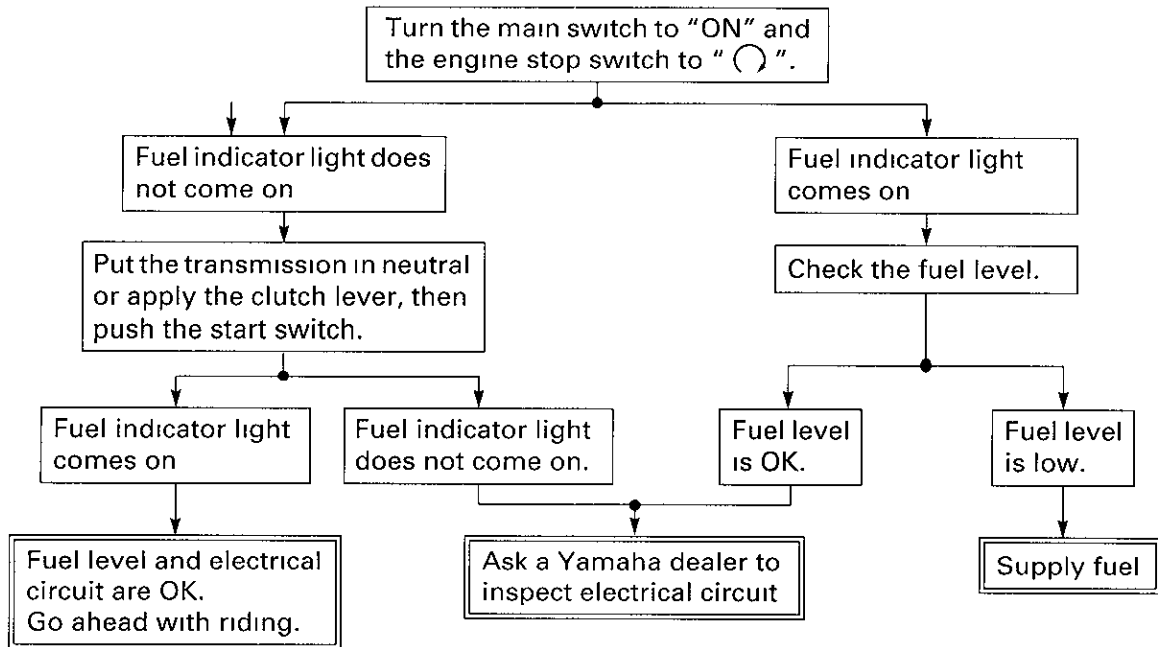

Speedometer

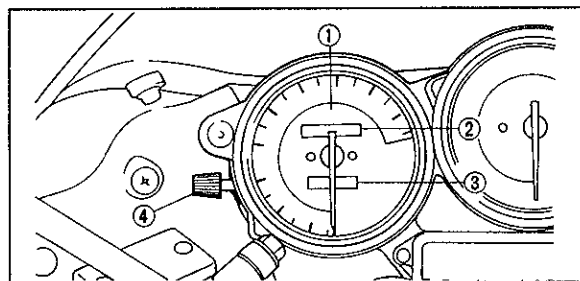

- 1 Speedometer
2 Odometer
3 Trip odometer
4 Reset knob

The speedometer shows riding speed. This speedometer is equipped with an odometer and trip odometer. The trip odometer can be reset to "0" with the reset knob. Use the trip odometer to estimate how far you can ride on a tank of fuel. This information will enable you to plan fuel stops in the future.

Tachometer

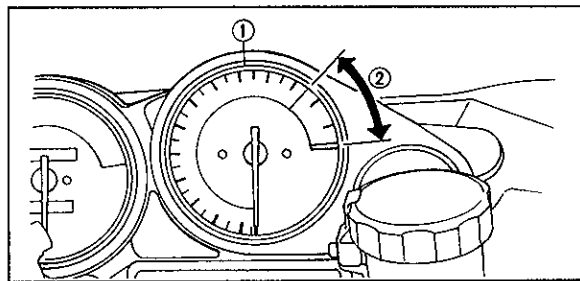

- 1 Tachometer
2 Red zone

This model is equipped with an electric tachometer so the rider can monitor the engine speed and keep it within the ideal power range.

EUU30400

CAUTION:

Do not operate in the red zone.
Red zone: 11,500 r/min and above

Diagnosis device

This model is equipped with a self diagnosis for the following circuits.

- Throttle Position Sensor (T.P.S.) circuit
- Exhaust Ultimate Power valve (EXUP) circuit
- Fuel level indicator circuit

If some trouble should occur in any of these circuits, the tachometer will repeatedly display as follows:

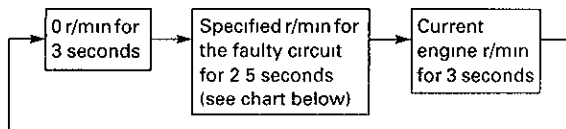

Use this chart to identify what circuit is faulty according to the specified r/min displayed.

Specified r/min	Faulty circuit
3,000 r/min	Throttle Position Sensor (T.P.S.)
7,000 r/min	Exhaust Ultimate Power valve (EXUP)
8,000 r/min	Fuel level indicator

If the tachometer displays as described above, take note of the specified r/min and then take your motorcycle to a Yamaha dealer for repair.

EUU47200

CAUTION:

To prevent engine damage, be sure to consult a Yamaha dealer as soon as possible if the tachometer displays a repeated change in rpm.

Engine temperature gauge

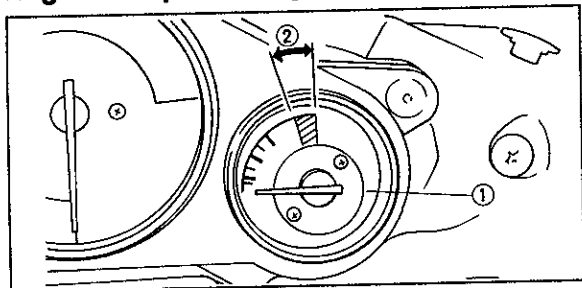

1. Engine temperature gauge 2. Red zone

This gauge indicates the coolant temperature when the main switch is on. The engine operating temperature will vary with changes in weather and engine load. If the needle points to the red zone or higher, stop your motorcycle and let the engine cool. (See page 3-5 for details.)

EUU30500

CAUTION:

When the engine is overheated, do not continue riding.

Handlebar switches

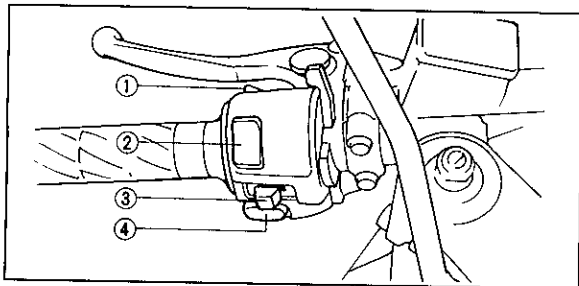

- | | |
|----------------------|-------------------|
| 1 Pass switch "PASS" | 2 Dimmer switch |
| 3 Turn signal switch | 4 Horn switch "📢" |

EAB63201

Pass switch "PASS"

Press the switch to operate the passing light.

EAB63400

Dimmer switch

Turn the switch to "☰" for the high beam and to "☷" for the low beam.

EAB63500

Turn signal switch

To signal a right-hand turn, push the switch to "➡". To signal a left-hand turn, push the switch to "⬅". Once the switch is released it will return to the center position. To cancel the signal, push the switch in after it has returned to the center position.

EAB63700

Horn switch "📢"

Press the switch to sound the horn.

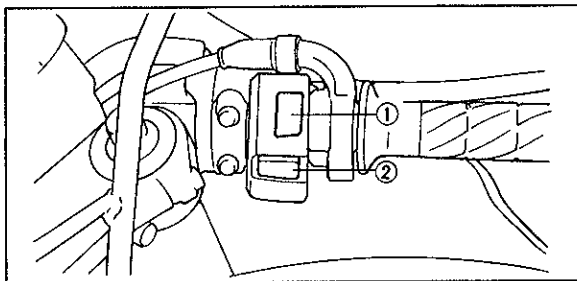

1. Engine stop switch

2 Start switch

EAB63800

Engine stop switch

The engine stop switch is a safety device for use in an emergency such as when the motorcycle overturns or if trouble occurs in the throttle system. Turn the switch to "⊙" to start the engine. In case of emergency, turn the switch to "⊗" to stop the engine.

EAB64100

Start switch "⊙"

The starter motor cranks the engine when pushing the start switch.

EUU30700

CAUTION:

See starting instructions prior to starting the engine.

Starter "N"

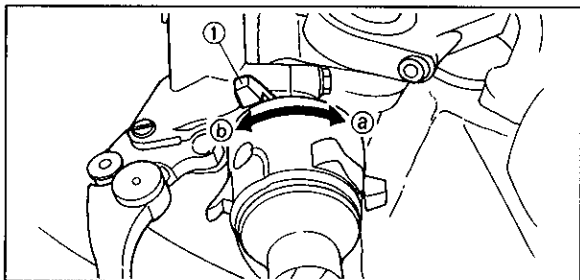

1 Starter "N"

Clutch lever

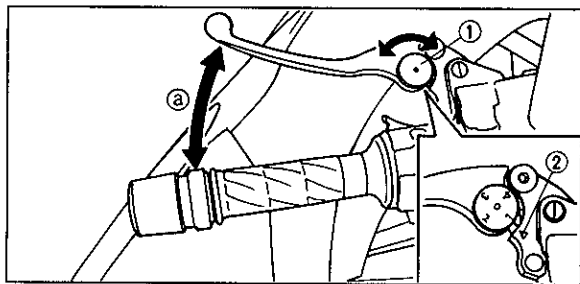
1 Lever position adjuster 2 Arrow mark
a Lever distance

Starting a cold engine requires a richer air-fuel mixture. A separate starter circuit supplies this mixture.

Move in direction ① to turn on the starter.
Move in direction ② to turn off the starter.

The clutch lever is located on the left handlebar. It is equipped with a lever position adjuster and a clutch switch which is integrated into the ignition circuit cut-off system. (Refer to the engine starting procedures for a description of this system.) To disengage the clutch, pull the clutch lever toward the handlebar. To engage the clutch, release the lever. The lever should be pulled rapidly and released slowly for smooth clutch operation.

Shift pedal

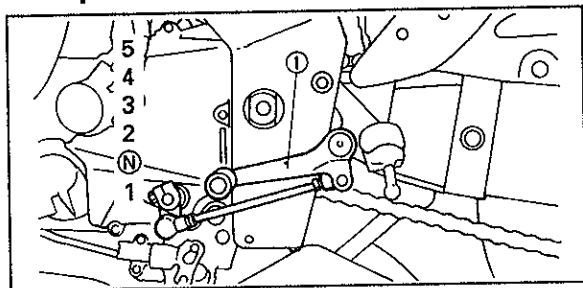

1. Shift pedal

N Neutral

To adjust the distance between the clutch lever and the handlebar grip, turn the adjuster while pushing the lever forward. Make sure the setting on the adjuster is aligned with the arrow mark.

This motorcycle is equipped with a constant-mesh 5-speed transmission. The shift pedal is located on the left side of the engine and is used in combination with the clutch when shifting.

Front brake lever

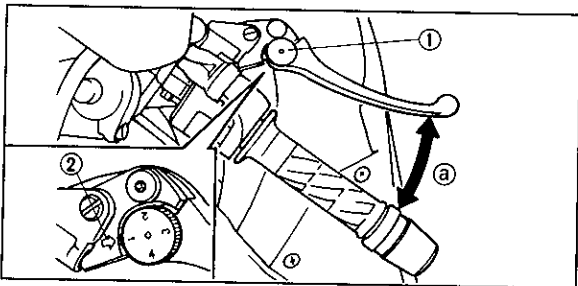

1 Lever position adjuster

2 Arrow mark

a Lever distance

The front brake lever is located on the right handlebar. Pull it toward the handlebar to activate the front brake. The front brake lever is equipped with a lever position adjuster. To adjust, turn the adjuster while pushing the lever forward and align the setting on the adjuster with the arrow mark.

Rear brake pedal

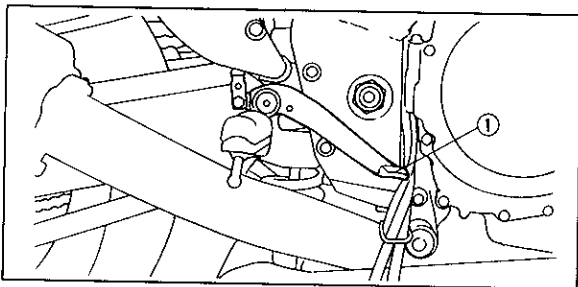

1 Rear brake pedal

The rear brake pedal is on the right side of the motorcycle. Press down on the brake pedal to apply the rear brake.

Fuel tank cap

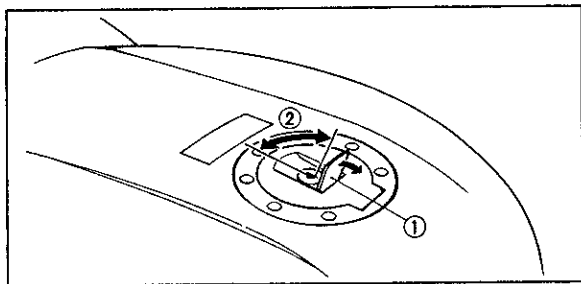

1. Key cover

2. Unlock

TO OPEN:

Open the key cover. Insert the key and turn it 1/4 turn clockwise. The lock will be released and the cap can be opened.

TO CLOSE:

Push the tank cap into position with the key inserted. To remove the key, turn it counterclockwise to the original position. Then, close the key cover.

EUU01200

NOTE: _____
 This tank cap cannot be closed unless the key is in the lock. The key cannot be removed if the cap is not locked properly.

EUU61100

⚠ WARNING _____

Be sure the cap is properly installed and locked in place before riding the motorcycle.

Steering lock

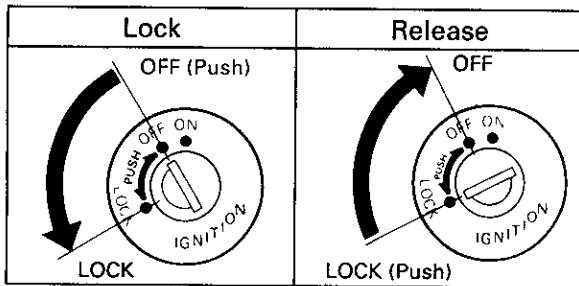

2

The steering is locked when the main switch is turned to "LOCK". To lock the steering, turn the handlebars all the way to the left. While pushing the key into the main switch, turn it from "OFF" to "LOCK" and remove it. To release the lock, turn the key to "OFF" while pushing.

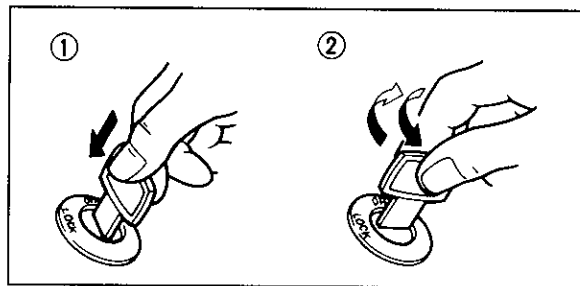

1 Push

2 Turn

EUU61400

⚠ WARNING

Never turn the key to "LOCK" when the motorcycle is moving.

Rider and passenger seat removal

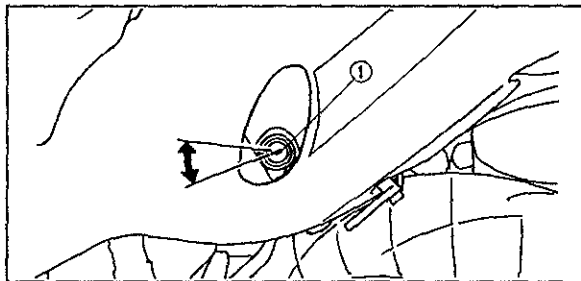

1. Rider seat lock

To remove the rider seat:
Insert the key into the seat lock and turn it as shown.

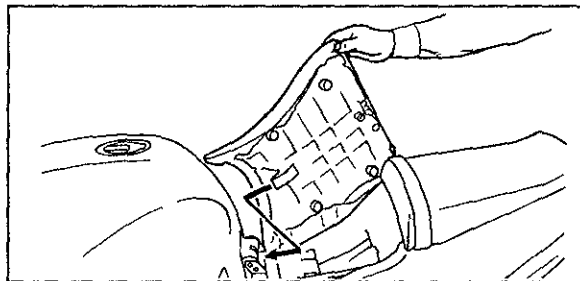

To install the rider seat:
Insert the lobe on the front of the seat into the receptacle on the frame. Then push down on the seat.

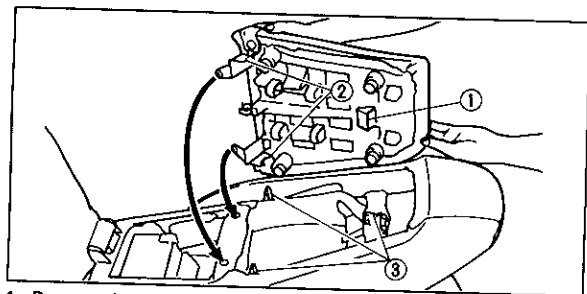

1 Receptacle 2 Hooks 3 Holders

To remove the passenger seat:

Remove the rider seat. Then pull upward on the passenger seat.

To install the passenger seat:

Insert the receptacle on the rear of the seat and the hooks on the front of the seat into the holders on the frame, and push the seat backward. Then install the rider seat.

Helmet holder

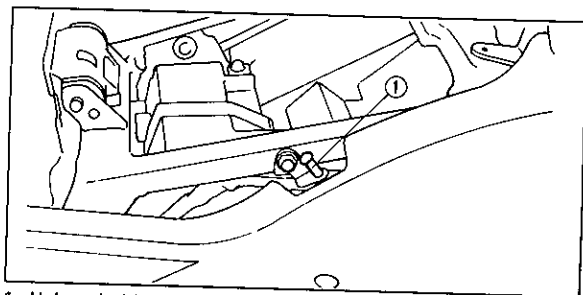

1 Helmet holder

The helmet holder is located under the rider's seat. Remove the rider's seat and hook the helmet on the helmet holder. Then lock the seat.

EUU72900

⚠ WARNING

Never ride with a helmet in the helmet holder. The helmet may hit objects, causing loss of control and possibly an accident.

Storage compartment

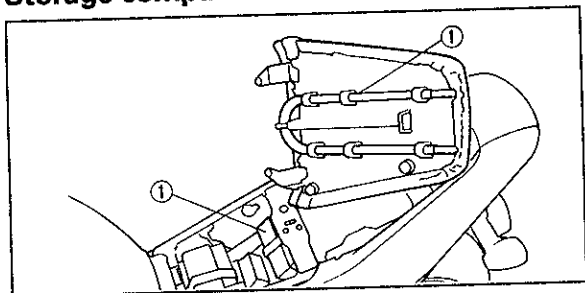

1 U-LOCK

This compartment is designed to store Yamaha genuine U-LOCKS. (Other locks may not fit.) Be sure the lock is fastened securely with the straps when storing it in the compartment. To prevent losing the straps, be sure to secure them even when a U-LOCK is not being stored in the compartment. When storing this Owner's manual or other documents in the compartment, be sure to put them in a vinyl bag so they don't get wet. When washing the motorcycle, be careful not to flood this compartment with water.

Front fork adjustment

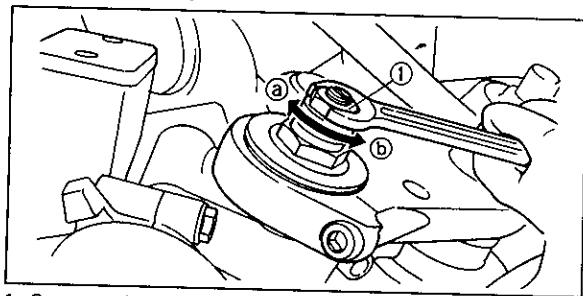

1 Spring preload adjuster

a Increase

b Decrease

This front fork is equipped with spring preload, rebound and compression damping force adjusters.

EUU66901

⚠ WARNING

Always adjust each fork leg to the same setting. Uneven adjustment can cause poor handling and loss of stability.

- Adjust spring preload as follows. Turn the adjuster in direction **Ⓐ** to increase spring preload and in direction **Ⓑ** to decrease spring preload.

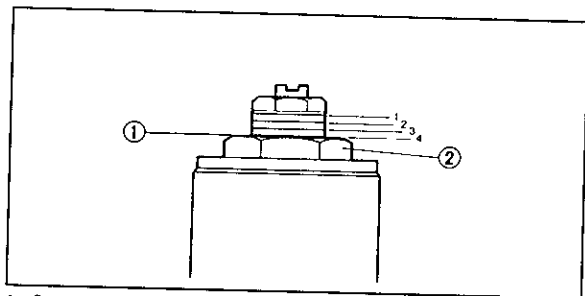

1 Setting position

2 Front fork cap

EUU43001

CAUTION:

The grooves are provided to show the adjustment level. Always keep the adjustment level equal on both fork legs.

	Hard	Standard	Soft
Adjusting position	1	2	3
			4

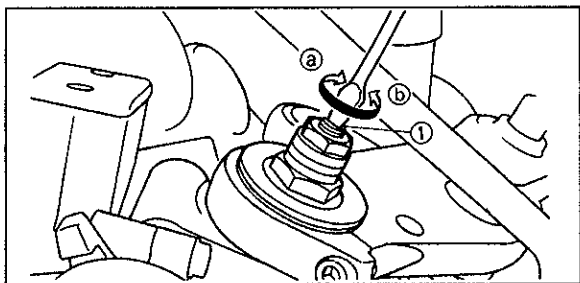

1. Rebound damping adjusting screw
 a Increase b Decrease

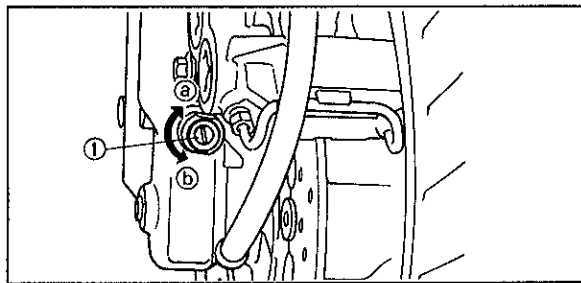

1. Compression damping adjusting screw
 a Increase b Decrease

2. Adjust rebound damping force as follows.

Turn the adjusting screw in direction Ⓐ to increase rebound damping force and in direction Ⓑ to decrease rebound damping force.

Standard	9 clicks out*
Minimum (Soft)	17 clicks out*
Maximum (Hard)	0 clicks out*

* From the fully turned-in position

3. Adjust compression damping force as follows.

Turn the adjusting screw in direction Ⓐ to increase compression damping force and in direction Ⓑ to decrease compression damping force.

Standard	12 clicks out*
Minimum (Soft)	21 clicks out*
Maximum (Hard)	0 clicks out*

* From the fully turned-in position.

EUA36301

CAUTION: _____

Never attempt to turn an adjuster beyond the maximum or minimum setting.

EAI61502

Rear shock absorber

EUA67301

 WARNING _____

This shock absorber contains highly pressurized nitrogen gas. Read and understand the following information before handling the shock absorber. The manufacturer cannot be held responsible for property damage or personal injury that may result from improper handling.

- 1. Do not tamper with or attempt to open the cylinder assembly.**
 - 2. Do not subject the shock absorber to an open flame or other high heat source. This may cause the unit to explode due to excessive gas pressure.**
 - 3. Do not deform or damage the cylinder in any way. Cylinder damage will result in poor damping performance.**
 - 4. Take your shock absorber to a Yamaha dealer for any service.**
-

Rear shock absorber adjustment

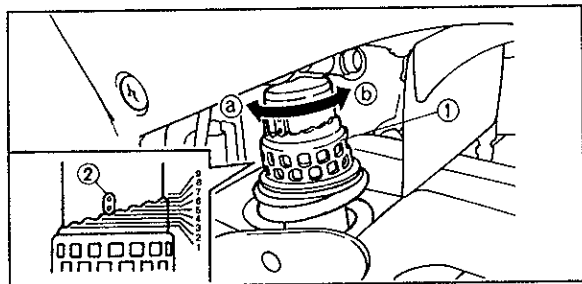

- 1 Spring preload adjusting ring
 2 Align stopper with preload position
 a Increase b Decrease

This shock absorber is equipped with spring preload, rebound and compression damping force adjusters.

EUU36301

CAUTION:

Never attempt to turn an adjuster beyond the maximum or minimum setting.

- Adjust spring preload as follows.
 Turn the adjusting ring in direction (a) to increase spring preload and in direction (b) to decrease spring preload.

	Soft ←			Standard	→ Hard				
Adjusting position	1	2	3	4	5	6	7	8	9

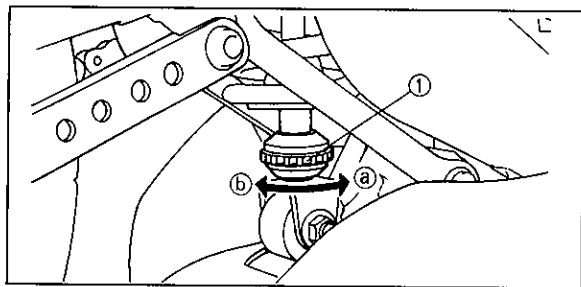

1 Rebound damping adjuster

a Increase

b Decrease

2. Adjust rebound damping force as follows.

Turn the adjuster in direction ① to increase rebound damping force and in direction ② to decrease rebound damping force.

Standard	10 clicks out*
Minimum (soft)	20 clicks out*
Maximum (hard)	0 clicks out*

* From the fully turned-in position

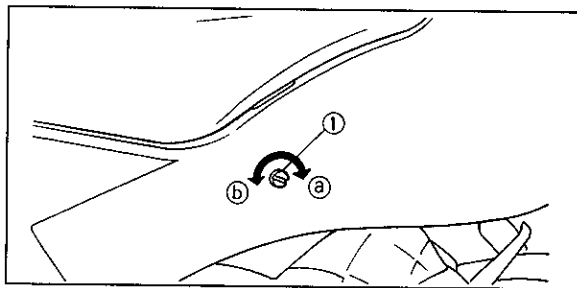

1 Compression damping adjusting screw

a Increase

b Decrease

3. Adjust compression damping force as follows.

Turn the adjusting screw in direction ① to increase compression damping force and in direction ② to decrease compression damping force.

Standard	10 clicks in*
Minimum (soft)	0 clicks in*
Maximum (hard)	24 clicks in*

* From the fully turned-out position

Luggage strap holders

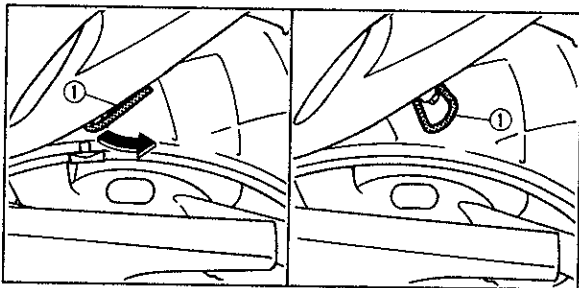

1 Luggage strap holder

EUU20700

NOTE: _____
Ask a Yamaha dealer to make this adjustment.

There are four luggage strap holders below the passenger seat, two of which can be turned outward for easier access.

Sidestand

2

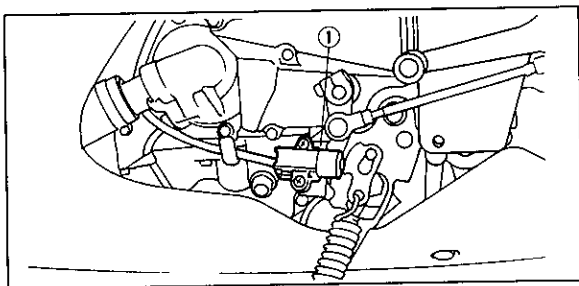

1 Sidestand switch

This model is equipped with an ignition circuit cut-off system. The motorcycle must not be ridden when the sidestand is down. The sidestand is located on the left side of the frame. (Refer to page 4-1 for an explanation of this system.)

⚠ WARNING

This motorcycle must not be operated with the sidestand in the down position. If the stand is not properly retracted, it could contact the ground and distract the operator, resulting in a possible loss of control. Yamaha has designed into this motorcycle a lockout system to assist the operator in fulfilling the responsibility of retracting the sidestand. Please check carefully the operating instructions listed below and if there is any indication of a malfunction, return the motorcycle to a Yamaha dealer immediately for repair.

Sidestand/clutch switch operation check

Check the operation of the sidestand switch and clutch switch against the information below.

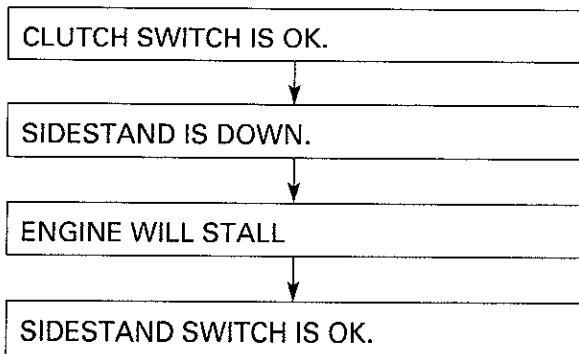
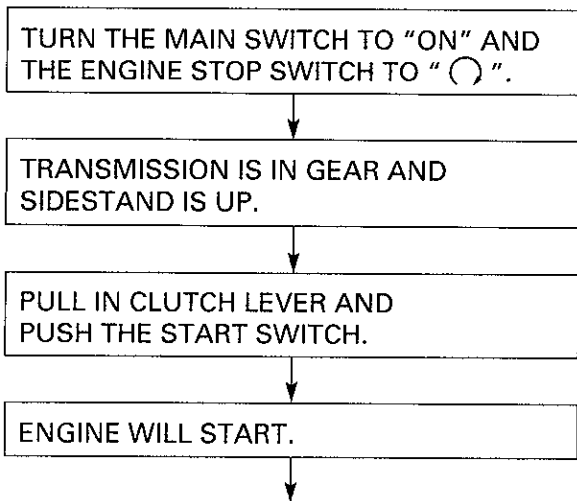

EUU69100

**WARNING**

If improper operation is noted, consult a Yamaha dealer immediately.

PRE-OPERATION CHECKS

Brakes.....	3-3
Brake/Clutch fluid leakage.....	3-4
Throttle grip.....	3-4
Engine oil.....	3-5
Coolant.....	3-7
Tires.....	3-8
Cast wheels and tires	3-12
Fittings and fasteners	3-13
Lights, signals and switches	3-13
Fuel.....	3-14

Owners are personally responsible for their vehicle's condition. Your motorcycle vital functions can start to deteriorate quickly and unexpectedly, even if it remains unused (for instance, if it is exposed to the elements) Any damage, fluid leak or loss of tire pressure could have serious consequences. Therefore, it is very important that, in addition to a thorough visual inspection, you check the following points before each ride.

ITEM	ROUTINE	PAGE
Fuel tank	• Check fuel level/fill with fuel as required.	3-13 ~ 3-14
Front brake	• Check operation, free play, fluid level and fluid leakage • Fill with DOT 4 brake fluid if necessary.	3-3 ~ 3-4, 5-21 ~ 5-26
Rear brake	• Check operation, free play, fluid level and fluid leakage • Fill with DOT 4 brake fluid if necessary	
Clutch	• Check operation, fluid level and fluid leakage • Fill with DOT 4 brake fluid if necessary.	3-4, 5-29
Throttle grip/housing	• Check for smooth operation • Lubricate if necessary	3-4, 5-18
Engine oil	• Check oil level/fill with oil as required	3-5, 5-8 ~ 5-12
Coolant reservoir tank	• Check coolant level/fill with coolant as required	3-5 ~ 3-6
Drive chain	• Check chain slack and condition • Adjust if necessary	5-26 ~ 5-28
Wheels/Tires	• Check tire pressure, wear and damage	3-7 ~ 3-11, 5-33
Control/Meter cable	• Check for smooth operation • Lubricate if necessary	5-28
Brake and shift pedal shafts	• Check for smooth operation • Lubricate if necessary	5-29

ITEM	ROUTINE	PAGE
Brake and clutch lever pivots	<ul style="list-style-type: none"> • Check for smooth operation • Lubricate if necessary 	5-29
Sidestand pivot	<ul style="list-style-type: none"> • Check for smooth operation. • Lubricate if necessary. 	5-30
Fittings/fasteners	<ul style="list-style-type: none"> • Check all chassis fittings and fasteners. • Tighten/Adjust if necessary. 	3-12
Lights and signals	<ul style="list-style-type: none"> • Check for proper operation. 	3-12, 5-37 ~ 5-38

NOTE:

Pre-operation checks should be made each time the motorcycle is used. Such an inspection can be thoroughly accomplished in a very short time; and the added safety it assures is more than worth the time involved.

⚠ WARNING

If any item in the **PRE-OPERATION CHECK** is not working properly, have it inspected and repaired before operating the motorcycle.

Brakes

1. Brake lever and brake pedal

This motorcycle's brake lever and pedal free play adjust automatically. Do not attempt to make any adjustments. Make sure the brakes are working properly by checking at low speed shortly after starting out.

2. Brake fluid

Check the brake fluid level and fill the master cylinder with brake fluid if necessary. (See page 5-26 for details.)

Recommended brake fluid: DOT 4

3. Check the brake pads. (See page 5-21 for details.)

EJU02201

NOTE:

When this brake service is necessary, consult a Yamaha dealer.

3

EJU61900

WARNING

A soft, spongy feeling in the brake lever (and/or brake pedal) indicates a failure in the brake system. Do not operate the motorcycle until the failure in the brake system is corrected. Ask a Yamaha dealer for immediate repairs. A soft, spongy feeling could indicate a hazardous condition in the brake system.

EAE11601

Brake/Clutch fluid leakage

Apply each brake and the clutch for a few minutes. Check to see if any brake fluid leaks out from the hose, joints, master cylinders, or plunger case.

EUU37801

CAUTION

Brake fluid may deteriorate painted surfaces or plastic parts. Never spill any fluid. If spilled, clean it up immediately.

ELU62500

⚠ WARNING

If brake fluid leakage is found, ask a Yamaha dealer for immediate repairs. Such leakage could indicate a hazardous condition.

EAE30101

Throttle grip

Turn the throttle grip to see if it operates properly, and check the throttle cable free play. (See page 5-18 for details.) Make sure the grip returns by spring force when released. Ask a Yamaha dealer to make any necessary adjustments.

Engine oil

Make sure the engine oil is at the specified level. Fill with oil as necessary (see page 5-8 for details).

3

Recommended oil:

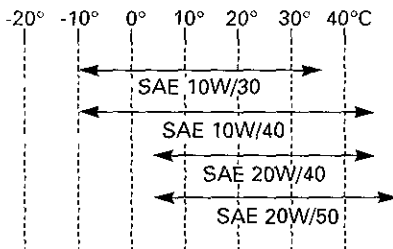

Recommended engine oil classification:

API Service "SE", "SF" type or equivalent
(e.g. "SF-SE", "SF-SE-CC", "SF-SE-SD" etc.)

Oil quantity:

Total amount:

3.5 L

Periodic oil change:

3.0 L

With oil filter replacement:

3.2 L

CAUTION: _____

Do not put in any chemical additives or use oils with a grade of "CD" or higher. Also, be sure not to use oils labeled "ENERGY CONSERVING II" or higher. Engine oil also lubricates the clutch and additives could cause clutch slippage.

Coolant

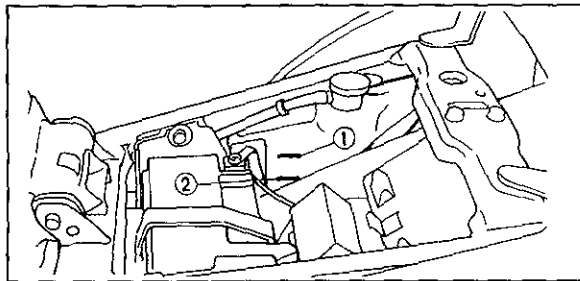

1 Maximum level

2 Minimum level

3

Check the coolant level in the reservoir tank when the engine is cold. The coolant level will vary with engine temperature. The coolant level is satisfactory if it is between the minimum and maximum marks on the tank. If the coolant level is at or below the minimum mark, fill with tap water (soft water) to bring the level up to the maximum mark. Have a Yamaha dealer change the coolant every two years.

EJU62600

⚠ WARNING

Do not remove the radiator cap when the engine is hot.

EJU30900

CAUTION

Hard water or salt water is harmful to the engine. You may use distilled water if you can't get soft water.

Reservoir tank capacity:
0.23 L

Tires

To ensure maximum performance, long service and safe operation, note the following:

1. Tire air pressure

Always check and adjust the tire pressure before operating the motorcycle.

EUU67500

WARNING

Tire inflation pressure should be checked and adjusted when the temperature of the tire equals the ambient air temperature. Tire inflation pressure must be adjusted according to total weight of cargo, rider, passenger, and accessories (fairing, saddlebags, etc. if approved for this model), and vehicle speed.

Basic weight* With oil and full fuel tank	224 kg	
Maximum load**	196 kg	
Cold tire pressure*	Front	Rear
Up to 90 kg load*	225 kPa (2.25 kg/cm ² , 2.25 bar)	250 kPa (2.50 kg/cm ² , 2.50 bar)
90 kg load ~ maximum load*	250 kPa (2.50 kg/cm ² , 2.50 bar)	290 kPa (2.90 kg/cm ² , 2.90 bar)
High speed riding	250kPa (2.50 kg/cm ² , 2.50 bar)	290 kPa (2.90 kg/cm ² , 2.90 bar)

* Load is the total weight of cargo, rider, passenger, and accessories

⚠ WARNING

3 Proper loading of your motorcycle is important for several characteristics of your motorcycle, such as handling, braking, performance and safety. Do not carry loosely packed items that can shift. Securely pack your heaviest items close to the center of the motorcycle, and distribute the weight evenly from side to side. Properly adjust the suspension for your load, and check the condition and pressure of your tires. **NEVER OVERLOAD YOUR MOTORCYCLE.** Make sure the total weight of the cargo, rider, passenger, and accessories (fairing, saddlebags, etc. if approved for this model) does not exceed the maximum load of the motorcycle. Operation of an overloaded motorcycle could cause tire damage, an accident, or even injury.

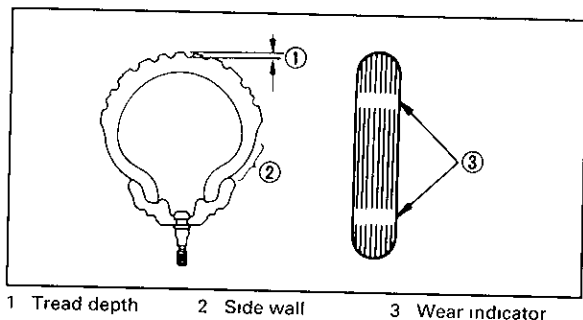

2. Tire inspection

Always check the tires before operating the motorcycle. If a tread depth shows crosswise lines (minimum tread depth), if the tire has a nail or glass fragments in it, or if the side wall is cracked, contact a Yamaha dealer immediately and have the tire replaced.

⚠ WARNING

It is dangerous to ride with a worn-out tire. When a tire tread begins to show lines, have a Yamaha dealer replace the tire immediately. Brakes, tires and related wheel parts replacement should be left to a Yamaha Service Technician.

Minimum tire tread depth (front and rear)	10 mm
--	-------

3. Tire information

This motorcycle is equipped with tubeless tires, tire valves and cast wheels.

⚠ WARNING

- After extensive tests, the tires mentioned below have been approved by Yamaha Motor Co., Ltd. for this model. No guarantee for handling characteristics can be given if tire combinations other than what is approved are used on this motorcycle. The front and rear tires should be of the same manufacture and design.
- The use of tire valves and valve cores other than listed below could cause tire deflation during extreme high speed riding. Always use genuine parts or their equivalent for replacement.
- Be sure to install the valve caps securely, as these are important to prevent air pressure leakage during extreme high speed riding.

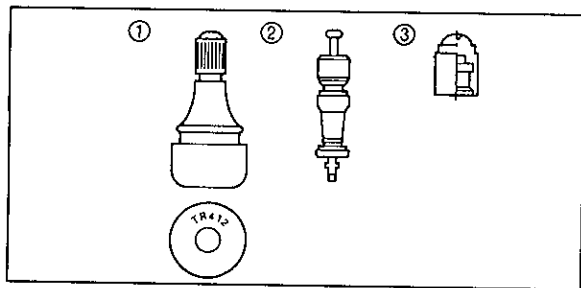

1 Tire valve

2 Valve core

3 Valve cap with seal

FRONT.

Manufacturer	Size	Type
Bridgestone	120/70 ZR17	BT50F
Dunlop	120/70 ZR17	D204FN
Michelin	120/70 ZR17	MACADAM 90XM
Michelin	120/70 ZR17	TX15
Metzeler	120/70 ZR17	MEZ1
Metzeler	120/70 ZR17	MEZ2
Pirelli	120/70 ZR17	MTR01
Pirelli	120/70 ZR17	MTR03

REAR

Manufacturer	Size	Type
Bridgestone	180/55 ZR17	BT50R
Dunlop	180/55 ZR17	D204M
Michelin	180/55 ZR17	MACADAM 90XM
Michelin	180/55 ZR17	TX25
Metzeler	180/55 ZR17	MEZ1
Metzeler	180/55 ZR17	MEZ2
Pirelli	180/55 ZR17	MTR02
Pirelli	180/55 ZR17	MTR04

	Type
Tire valve	TR412
Valve core	#9000A (original)

⚠ WARNING

This motorcycle is fitted with super high-speed running tires. The following points must be observed in order for you to make fully effective use of these tires.

- 1. Never fail to use the specified tires in tire replacement. Other tires may have a danger of bursting at super high-speeds.**
- 2. New tires have a relatively low grip on the road surface until they have been slightly worn. Therefore, approximately 100 km should be traveled at normal speed before any high-speed riding is done.**
- 3. Before any high-speed runs, the tires should be warmed-up sufficiently.**
- 4. Always inflate to the correct tire pressure according to the operating conditions.**

Cast wheels and tires

To ensure maximum performance, long service, and safe operation, note the following:

1. Always inspect the wheels before a ride. Check for cracks, bends, or warpage of the wheels. If any abnormal condition exists in a wheel, consult a Yamaha dealer. Do not attempt even small repairs to the wheel. If a wheel is deformed or cracked, it must be replaced.
2. Tires and wheels should be balanced whenever either one is changed or replaced. Failure to have a wheel balanced can result in poor performance, adverse handling characteristics, and shortened tire life.
3. Ride at moderate speeds after changing a tire since the tire surface must first be broken in for it to develop its optimal characteristics.

Fittings and fasteners

Always check the tightness of chassis fittings and fasteners before a ride. Take the motorcycle to a Yamaha dealer or refer to the Service Manual for correct tightening torque.

Lights, signals and switches

- Check all the lights, meter lights and indicator lights to make sure they are in working condition.
- Check the operation of the handlebar switches and main switch.

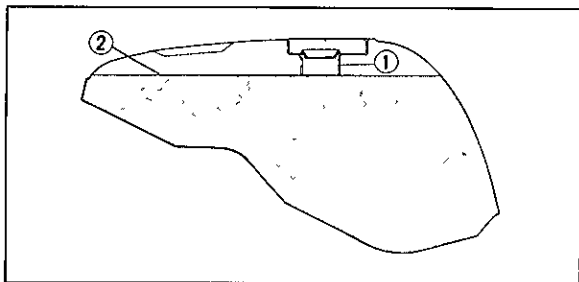
Fuel

1 Filler tube

2 Fuel level

Make sure there is sufficient fuel in the tank.

EUU61000

⚠ WARNING

Do not overfill the fuel tank. Avoid spilling fuel on the hot engine. Do not fill the fuel tank above the bottom of the filler tube as shown in the illustration or it may overflow when the fuel heats up later and expands.

EAE80900

Recommended fuel:
 Regular gasoline
 For Australia:
 Unleaded fuel only
 Fuel tank capacity:
 Total:
 20 L
 Reserve:
 4.5 L

OPERATION AND IMPORTANT RIDING POINTS

Starting and warming up a cold engine.....	4-1
Starting a warm engine.....	4-4
Shifting.....	4-5
Engine break-in	4-5
Parking	4-7

⚠ WARNING

1. **Before riding this motorcycle, become thoroughly familiar with all operating controls and their functions. Consult a Yamaha dealer regarding any control or function that you do not thoroughly understand.**
2. **Never start your engine or let it run for any length of time in a closed area. The exhaust fumes are poisonous and can cause loss of consciousness and death within a short time. Always operate your motorcycle in an area with adequate ventilation.**
3. **Before starting out, always be sure the sidestand is up. Failure to retract the sidestand completely can result in a serious accident when you try to turn a corner.**

Starting and warming up a cold engine**NOTE:**

This motorcycle is equipped with an ignition circuit cut-off system.

1. The engine can be started only under the following conditions:
 - a. The transmission is in neutral.
 - b. The sidestand is up, the transmission is in gear and the clutch is disengaged.
2. The motorcycle must not be ridden when the sidestand is down.

⚠ WARNING

Before going through the following steps, check the function of the sidestand switch and clutch switch. (Refer to page 2-28.)

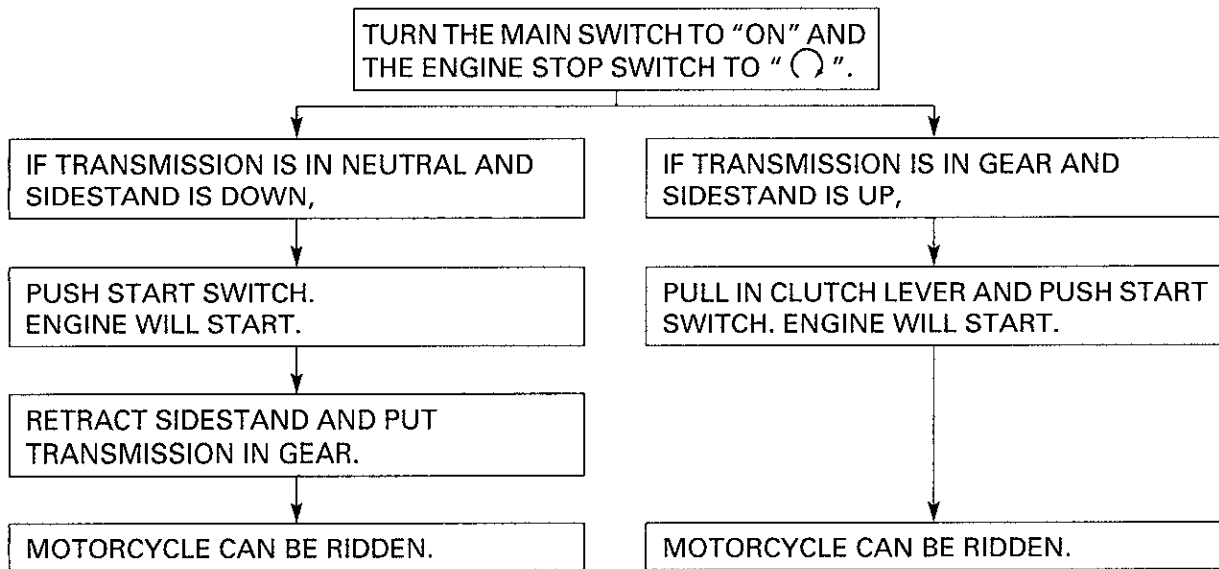

1. Turn the main switch to "ON" and the engine stop switch to "○".

EUU39903

CAUTION: _____

If the fuel indicator light comes on, check the fuel level. If necessary, fill the tank with fuel.

2. Shift the transmission into neutral.

EUU03001

NOTE: _____

When the transmission is in neutral, the neutral indicator light should be on. If the light does not come on, ask a Yamaha dealer to inspect it.

3. Turn on the starter "↘" and completely close the throttle grip.
4. Start the engine by pushing the start switch.

EUU02501

NOTE: _____

If the engine fails to start, release the start switch, wait a few seconds, then try again. Each attempt should be as short as possible to preserve the battery. Do not crank the engine more than 10 seconds on any one attempt.

EUU39802

CAUTION: _____

The oil level indicator light and fuel indicator light should come on when the start switch is pushed and should go off when the start switch is released. If the oil level indicator light flickers or remains on, immediately stop the engine and check the engine oil level and for oil leakage. If necessary, fill the engine with oil and check to see that the oil level indicator light goes off. If not, consult a Yamaha dealer.

5. After starting the engine, move the starter “|” to the warming up position.

EUU02600

NOTE:

For maximum engine life, always warm up the engine before starting off. Never accelerate hard with a cold engine.

6. After warming up the engine, turn off the starter “|” completely.

EUU02701

NOTE:

The engine is warm when it responds normally to the throttle with the starter “|” turned off.

EAF10802

Starting a warm engine

The starter “|” is not required when the engine is warm.

EUU31401

CAUTION:

See the “Engine break-in” section prior to operating the motorcycle for the first time.

Shifting

The transmission lets you control the amount of power you have available at a given speed for starting, accelerating, climbing hills, etc. The use of the shift pedal is shown in the illustration. (Page 2-14) To shift into neutral, depress the shift pedal repeatedly until it reaches the end of its travel, then raise the pedal slightly.

EUU31501

CAUTION:

1. **Do not coast for long periods with the engine off, and do not tow the motorcycle a long distance. Even with gears in neutral, the transmission is only properly lubricated when the engine is running. Inadequate lubrication may damage the transmission.**
2. **Always use the clutch when changing gears. The engine, transmission, and driveline are not designed to withstand the shock of forced shifting and can be damaged by shifting without using the clutch.**

Engine break-in

There is never a more important period in the life of your motorcycle than the period between zero and 1,000 km. For this reason we ask that you carefully read the following material. Because the engine is brand new, you must not put an excessive load on it for the first 1,000 km. The various parts in the engine wear and polish themselves to the correct operating clearances. During this period, prolonged full throttle operation, or any condition which might result in excessive heating of the engine, must be avoided.

1. 0 ~ 150 km:

Avoid operation above 7,000 r/min. Stop the engine and let it cool for 5 to 10 minutes after every hour of operation. Vary the speed of the motorcycle from time to time. Do not operate it at one set throttle position.

2. 150 ~ 500 km:

Avoid prolonged operation above 8,000 r/min. Rev the motorcycle freely through the gears, but do not use full throttle at any time.

3. 500 ~ 1,000 km:

Avoid prolonged full throttle operation. Avoid cruising speeds in excess of 9,000 r/min.

CAUTION:

After 1,000 km of operation, be sure to replace the engine oil and oil filter.

4. 1,000 km and beyond:

Full throttle can be used.

CAUTION:

-
- **Never let engine speeds enter the red zone.**
 - **If any engine trouble should occur during the break-in period, consult a Yamaha dealer immediately.**
-

Parking

When parking the motorcycle, stop the engine and remove the ignition key.

EUU63000

WARNING

The muffler and exhaust pipe are hot. Park the motorcycle in a place where pedestrians or children are not likely to touch the motorcycle. Do not park the motorcycle on a slope or soft ground; the motorcycle may overturn.

PERIODIC MAINTENANCE AND MINOR REPAIR

Tool kit	5-2	Brake fluid replacement.....	5-26
Periodic maintenance / lubrication	5-3	Drive chain slack check.....	5-26
Cowling/Panel removal and installation.....	5-6	Drive chain slack adjustment.....	5-27
Engine oil.....	5-8	Drive chain lubrication.....	5-28
Radiator fan	5-12	Cable inspection and lubrication	5-28
Air filter	5-13	Brake and shift pedal lubrication.....	5-29
Carburetor adjustment.....	5-16	Brake and clutch lever lubrication	5-29
Idle speed adjustment.....	5-17	Sidestand lubrication	5-30
Throttle cable free play adjustment	5-18	Rear suspension lubrication	5-30
Valve clearance adjustment	5-18	Front fork inspection.....	5-31
Spark plug inspection	5-19	Steering inspection	5-32
Brake light switch adjustment.....	5-21	Wheel bearings.....	5-33
Checking the front and rear brake pads.....	5-21	Battery	5-33
Inspecting the brake fluid level	5-23	Fuse replacement.....	5-35
		Headlight bulb replacement.....	5-37
		Troubleshooting	5-39
		Troubleshooting chart	5-40

EAH00400

Periodic inspection, adjustment and lubrication will keep your motorcycle in the safest and most efficient condition possible. Safety is an obligation of the motorcycle owner. The maintenance and lubrication schedule chart should be considered strictly as a guide to general maintenance and lubrication intervals. YOU MUST TAKE INTO CONSIDERATION THAT WEATHER, TERRAIN, GEOGRAPHICAL LOCATIONS, AND A VARIETY OF INDIVIDUAL USES ALL TEND TO DEMAND THAT EACH OWNER ALTER THIS TIME SCHEDULE TO SHORTER INTERVALS TO MATCH THE ENVIRONMENT.

5

The most important points of motorcycle inspection, adjustment, and lubrication are explained in the following pages.

EUU63200

 **WARNING**

If you are not familiar with motorcycle service, this work should be done by a Yamaha dealer.

Tool kit

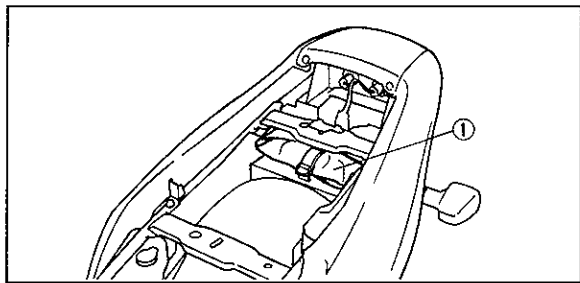

1 Tool kit

The service information included in this manual is intended to provide you, the owner, with the necessary information for completing some of your own preventive maintenance and minor repairs. The tools provided in the owner's tool kit are to assist you in the performance of periodic maintenance. However, some other tools such as a torque wrench are also necessary to perform the maintenance correctly.

EUU18500

NOTE:

If you do not have necessary tools required during a service operation, take your motorcycle to a Yamaha dealer for service.

EUU67100

⚠ WARNING

Modifications to this motorcycle not approved by Yamaha may cause loss of performance, and render it unsafe for use. Consult a Yamaha dealer before attempting any changes.

PERIODIC MAINTENANCE / LUBRICATION

ITEM	ROUTINE	BREAK-IN 1,000 km	EVERY	
			6,000 km or 6 months	12,000 km or 12 months
* Valves	<ul style="list-style-type: none"> • Check valve clearance • Adjust if necessary 	EVERY 42,000 km or 42 months		
Spark plugs	<ul style="list-style-type: none"> • Check condition • Clean or replace if necessary 	○	○	○
Air filter	<ul style="list-style-type: none"> • Clean • Replace if necessary 		○	○
* Carburetor	<ul style="list-style-type: none"> • Check idle speed/synchronization/starter operation • Adjust if necessary 	○	○	○
* Fuel line	<ul style="list-style-type: none"> • Check fuel hose for cracks or damage • Replace if necessary 		○	○
* Fuel filter	<ul style="list-style-type: none"> • Check condition • Replace if necessary 			○
Engine oil	<ul style="list-style-type: none"> • Replace (Warm engine before draining) 	○	○	○
* Engine oil filter	<ul style="list-style-type: none"> • Replace 	○		○
* Brakes	<ul style="list-style-type: none"> • Check operation/fluid leakage/See NOTE (Page 5-5) • Correct if necessary 		○	○
* Clutch	<ul style="list-style-type: none"> • Check operation/fluid leakage/See NOTE (Page 5-5) • Correct if necessary 		○	○
* Swingarm pivot	<ul style="list-style-type: none"> • Check swingarm assembly for looseness • Correct if necessary • Moderately repack every 24,000 km or 24 months*2 			○

ITEM	ROUTINE	BREAK-IN 1,000 km	EVERY	
			6,000 km or 6 months	12,000 km or 12 months
* Rear suspension link pivots	<ul style="list-style-type: none"> • Check operation • Apply grease lightly every 24,000 km or 24 months*2 			○
* Wheels	<ul style="list-style-type: none"> • Check balance/damage/runout • Replace if necessary. 		○	○
* Wheel bearings	<ul style="list-style-type: none"> • Check bearings assembly for looseness/damage • Replace if damaged. 		○	○
* Steering bearings	<ul style="list-style-type: none"> • Check bearings assembly for looseness • Correct if necessary • Moderately repack every 24,000 km or 24 months*1 	○		○
* Front fork	<ul style="list-style-type: none"> • Check operation/oil leakage. • Repair if necessary 		○	○
* Rear shock absorber	<ul style="list-style-type: none"> • Check operation/oil leakage. • Repair if necessary 		○	○
* Cooling system	<ul style="list-style-type: none"> • Check coolant leakage. • Repair if necessary • Replace coolant every 24,000 km or 24 months 		○	○
Drive chain	<ul style="list-style-type: none"> • Check chain slack/alignment. • Adjust if necessary. • Clean and lube. 	Every 1,000 km or after washing the motorcycle or riding in the rain.		
* Fittings/Fasteners	<ul style="list-style-type: none"> • Check all chassis fittings and fasteners. • Correct if necessary 	○	○	○
* Sidestand	<ul style="list-style-type: none"> • Check operation • Repair if necessary 	○	○	○

ITEM	ROUTINE	BREAK-IN 1,000 km	EVERY	
			6,000 km or 6 months	12,000 km or 12 months
◀ Sidestand switch	<ul style="list-style-type: none"> • Check operation • Repair if necessary 	○	○	○

× It is recommended that these items be serviced by a Yamaha dealer

×1 Lithium soap base grease

×2 Molybdenum disulfide grease

NOTE:

Brake fluid replacement:

1. When disassembling the master cylinder, caliper cylinder or clutch release cylinder, replace the brake fluid. Normally check the brake fluid level and add fluid as required.
2. On the inner parts of the master cylinder, caliper cylinder and clutch release cylinder, replace the oil seals every two years.
3. Replace the brake and clutch hoses every four years, or if cracked or damaged.

Cowling/Panel removal and installation

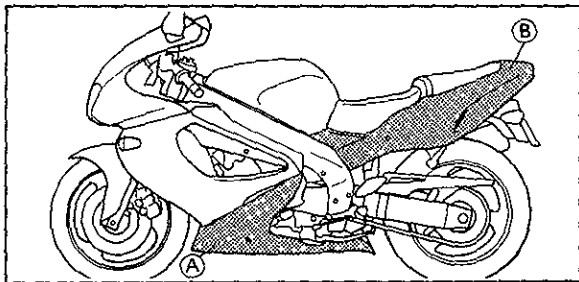

The cowlings/panels indicated in the illustration need to be removed to perform some of the maintenance described in this chapter. Refer to this section each time a cowling/panel has to be removed or reinstalled.

Cowling A

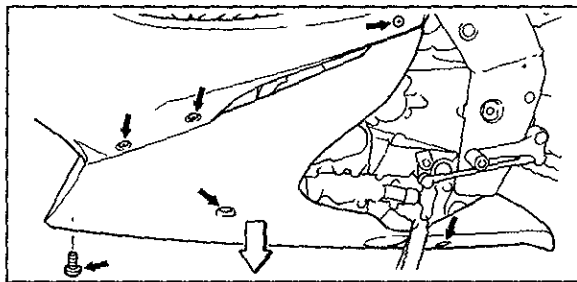

Screw (x 6)

To remove:

Remove the screws and pull outward on the areas shown.

To install:

Place in the original position and install the screws.

Cowling B

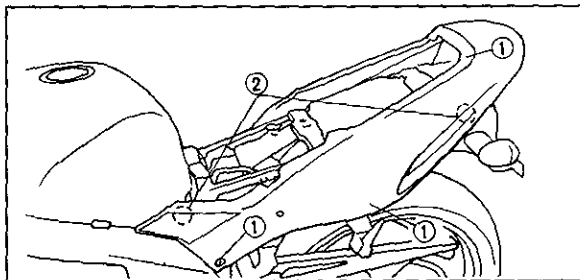

1 Screw (x 3)

2 Pull

To remove:
Remove the screws.

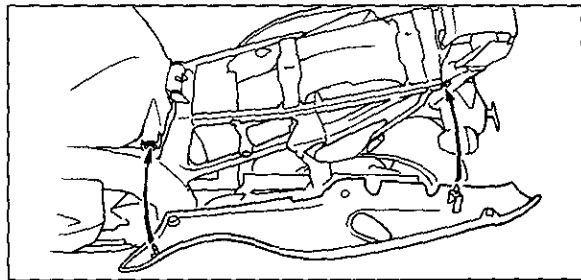

To install:
Place in the original position and install the screws.

Engine oil

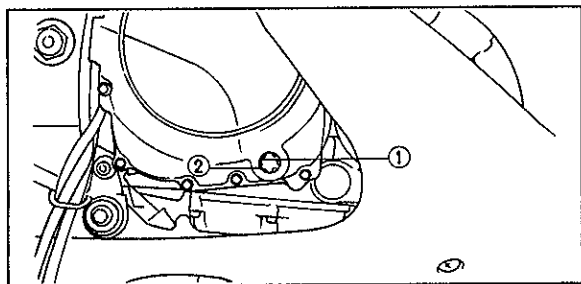

1. Maximum level

2. Minimum level

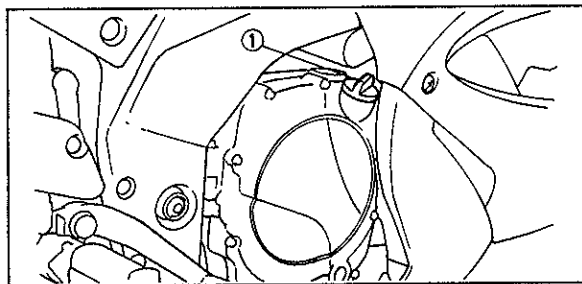

1. Oil filler cap

1. Oil level inspection

- a. Place the motorcycle on a level place and hold it in an upright position. Warm up the engine for several minutes.

EUU03901

NOTE:

Be sure the motorcycle is positioned straight up when checking the oil level. A slight tilt toward the side can result in false readings.

- b. With the engine stopped, check the oil level through the level window located at the lower part of the right side crankcase cover.

EUU04000

NOTE:

Wait a few minutes until the oil level settles before checking.

- c. The oil level should be between maximum and minimum marks. If the level is low, fill the engine with sufficient oil to reach the specified level.

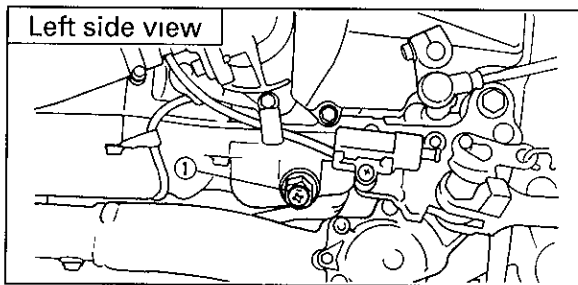

1 Drain plug

2. Engine oil and oil filter cartridge replacement
 - a. Remove cowling A. (See page 5-6.)
 - b. Warm up the engine for several minutes.
 - c. Stop the engine. Place an oil pan under the engine and remove the oil filler cap.
 - d. Remove the drain plug and drain the oil.

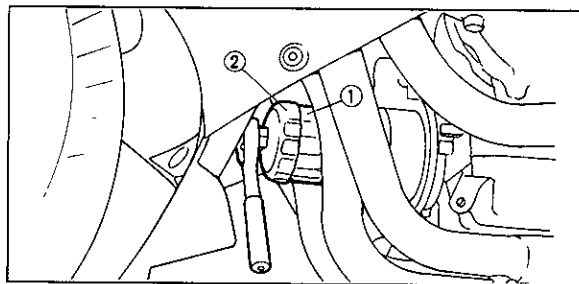

1 Oil filter

2 Oil filter wrench

- e. Remove the oil filter by using an oil filter wrench.

EUU13001

NOTE:

An oil filter wrench is available at a nearby Yamaha dealer.

- f. Reinstall the drain plug and tighten it to the specified torque.

Tightening torque:
 Drain plug:
 43 Nm (4.3 m·kg)

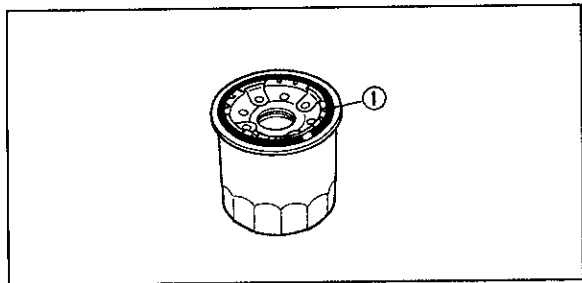

1 O-ring

- g. Apply a light coat of engine oil to the O-ring of the new oil filter.

EUU04101

NOTE:
Make sure the O-ring is seated properly.

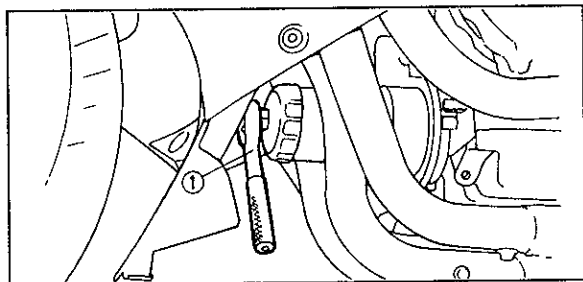

1 Torque wrench

- h. Install the oil filter and tighten it to the specified torque with an oil filter wrench.

Tightening torque:
Oil filter:
17 Nm (1.7 m·kg)

- i. Fill the engine with sufficient oil to reach the specified level. Install the oil filler cap and tighten it.

Recommended oil:

See page 3-5.

Oil quantity:

Total amount:

3.5 L

Periodic oil change:

3.0 L

With oil filter replacement:

3.2 L

EUU32401

CAUTION:

- **Do not put in any chemical additives. Engine oil also lubricates the clutch and additives could cause clutch slippage.**
 - **Be sure no foreign material enters the crankcase.**
-

- j. Start the engine and warm it up for several minutes. While warming up, check for oil leakage. If oil leakage is found, stop the engine immediately and check for the cause.

Radiator fan**Operation**

The electric fan operation is completely automatic. It is switched on or off according to the coolant temperature in the radiator.

- k. After the engine is started, the oil level indicator light should go off if the oil is at the specified level.

EUU35101

CAUTION

If the indicator light flickers or remains on, immediately stop the engine and consult with a Yamaha dealer.

- l. Install cowling A. (See page 5-6.)

Air filter

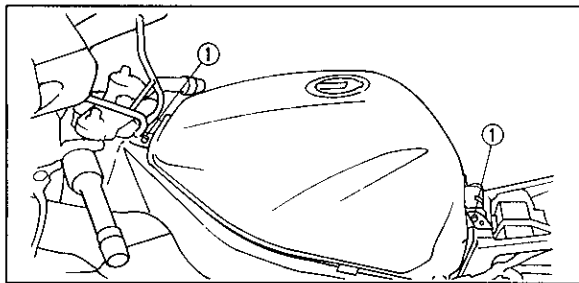

1 Fuel tank holding bolt (× 2)

The air filter should be cleaned at the specified intervals. It should be cleaned more frequently if you are riding in unusually wet or dusty areas.

1. Remove the seats.
2. Remove cowling B from each side. (See page 5-7.)
3. Remove the bolts holding the fuel tank.

4. Lift the fuel tank upward and position it away from the air filter case. (Do not remove the fuel hoses.)

EUU80300

⚠ WARNING

- **Support the fuel tank carefully during this procedure.**
- **Do not tilt the fuel tank too much or pull it too hard because the fuel hose connections may become loose causing fuel leakage.**

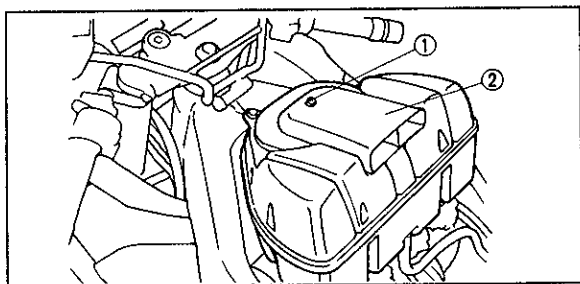

1 Screw

2 Cover

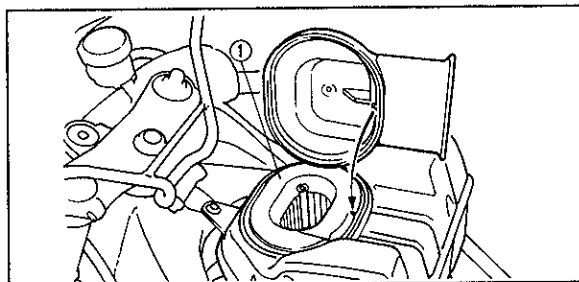

1 Air filter

5. Remove the screw holding the air filter case cover.
6. Pull out the air filter.

7. Tap the air filter lightly to remove most of the dust and dirt. Blow out the remaining dirt with compressed air as shown. If the air filter is damaged, replace it.
8. Reinstall by reversing the removal procedure.

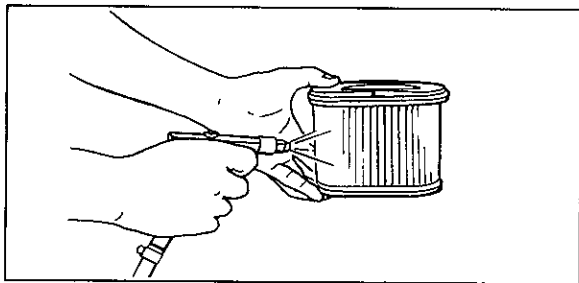

EUU42402

CAUTION

5

- Make sure the air filter is properly seated in the filter case.
- The engine should never be run without the air filter installed. Excessive piston and/or cylinder wear may result.

EUU78500

⚠ WARNING

- Before reinstallation, make sure that the fuel hoses are not damaged at all. If any damage is found, it may result in a fuel leak, so do not start the engine. Ask a Yamaha dealer for repairs.
- Always make sure that the fuel hoses are properly connected, in place, and not pinched.

Carburetor adjustment

The carburetors are important parts of the engine and require very sophisticated adjustment. Most adjustments should be left to a Yamaha dealer who has the professional knowledge and experience to do so. However, the idle speed may be adjusted by the owner as part of routine maintenance.

CAUTION

The carburetors were set at the Yamaha factory after many tests. If they are changed, poor engine performance and damage may result.

Idle speed adjustment

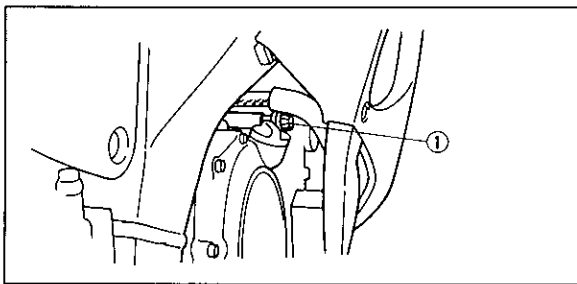

1 Throttle stop screw

1. Start the engine and warm it up for a few minutes (normally, 1 or 2 minutes) at approximately 1,000 to 2,000 r/min. Occasionally rev the engine to 4,000 to 5,000 r/min. The engine is warm when it quickly responds to the throttle.
2. Set the idle to the specified engine speed by adjusting the throttle stop screw; turn the screw in to increase engine speed, and out to decrease engine speed.

Standard idle speed:
1,100 r/min

EUU04500

NOTE: _____
If the specified idle speed cannot be obtained by performing the above adjustment, consult a Yamaha dealer.

Throttle cable free play adjustment

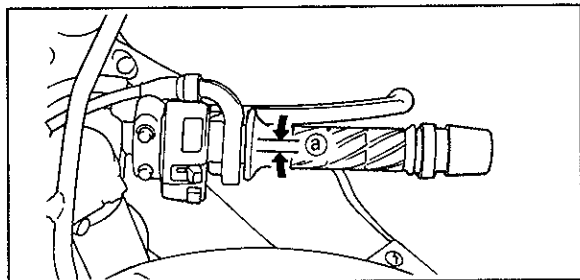

a. Free play

NOTE:

Before checking the throttle cable free play, the engine idling speed should be adjusted.

The throttle cables should have a specified free play in the turning direction at the grip flange. If the free play is incorrect, ask a Yamaha dealer to make this adjustment.

Free play:
3 ~ 7 mm

Valve clearance adjustment

The correct valve clearance changes with use, resulting in improper fuel/air supply or engine noise. To prevent this, the valve clearance must be adjusted regularly. This adjustment however, should be left to a professional Yamaha service technician.

Spark plug inspection

The spark plug is an important engine component and is easy to inspect. The condition of the spark plug can indicate the condition of the engine.

Normally, all spark plugs from the same engine should have the same color on the white insulator around the center electrode. The ideal color at this point is a medium-to-light tan color for a motorcycle that is being ridden normally. If one spark plug shows a distinctly different color, there could be something wrong with the engine.

Do not attempt to diagnose such problems yourself. Instead, take the motorcycle to a Yamaha dealer. You should periodically remove and inspect the spark plugs because heat and deposits will cause any spark plug to slowly break down and erode. If electrode erosion becomes excessive, or if carbon and other deposits are excessive, you should replace the spark plug with the specified plug.

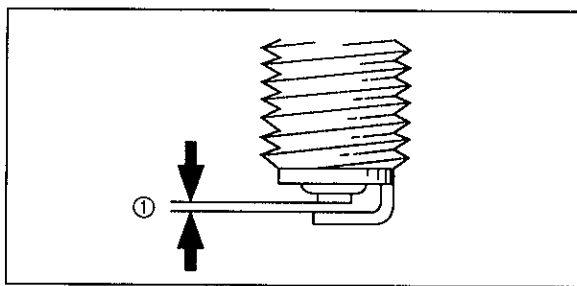

1 Spark plug gap

Specified spark plug:
 DR8EA (NGK)
 X24ESR-U (NIPPONDENSO)

Before installing any spark plug, measure the electrode gap with a wire thickness gauge. Adjust the gap to specification.

Spark plug gap:
 0.6 ~ 0.7 mm

When installing the spark plug, always clean the gasket surface and use a new gasket. Wipe off any grime from the threads and tighten the spark plug to the specified torque.

Tightening torque: Spark plug: 18 Nm (1.8 m·kg)

EUU03802

NOTE: _____

If a torque wrench is not available when you are installing a spark plug, a good estimate of the correct torque is 1/4 to 1/2 turn past finger tight. Have the spark plug tightened to the specified torque as soon as possible.

Brake light switch adjustment

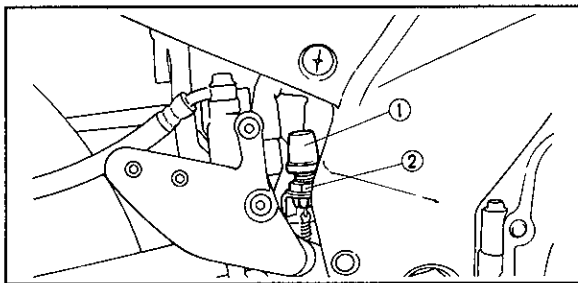

1 Rear brake switch 2 Adjusting nut

The brake light switch is operated by movement of the brake pedal. To adjust, hold the main body of the switch so it does not rotate and turn the adjusting nut. Proper adjustment is achieved when the brake light comes on just before the brake begins to take effect.

Checking the front and rear brake pads

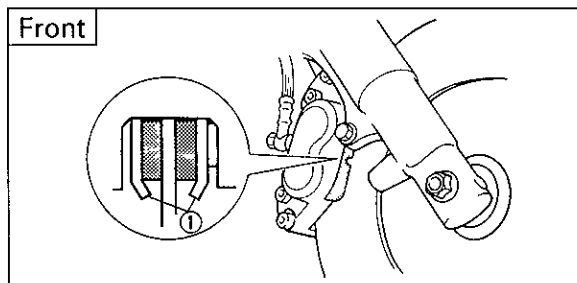

1 Wear indicator

A wear indicator is provided on each brake. This indicator allows checking of brake pad wear without disassembling the brake. Apply the brake and inspect the wear indicator. If the indicator is **ALMOST** in contact with the disc plate, ask a Yamaha dealer to replace the pads.

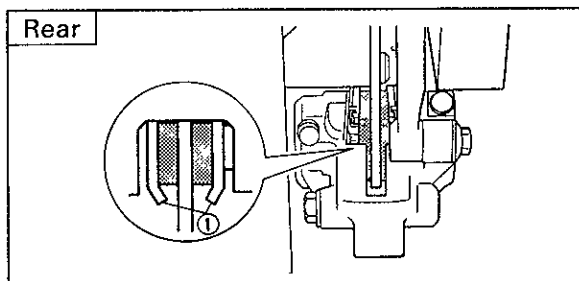

1 Wear indicator

Inspecting the brake fluid level

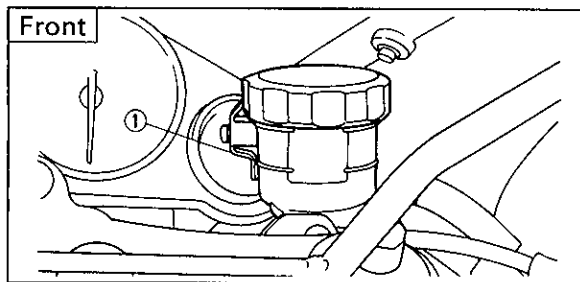

1 Minimum level

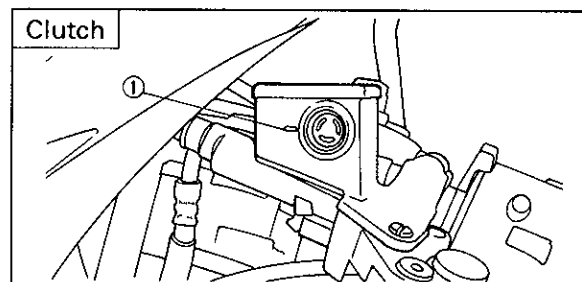

1 Minimum level

Insufficient brake fluid may let air enter the brake or clutch system, possibly causing them to become ineffective. Before riding, check that the brake fluid is above the minimum level and replenish when necessary.

Observe these precautions:

1. When checking the fluid level, make sure the top of the master cylinder is level by turning the handlebars.
2. Use only the designated quality brake fluid. Otherwise, the rubber seals may deteriorate, causing leakage and poor brake or clutch performance.

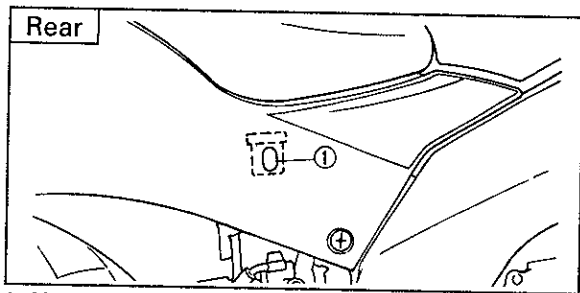

1. Minimum level

Recommended brake fluid: DOT 4

EUU19601

NOTE:

Brake fluid is also used for a hydraulic clutch.

DOT 4 or DOT 3 brake fluid can be used for the clutch system.

3. Refill with the same type of brake fluid. Mixing fluids may result in a harmful chemical reaction and lead to poor brake or clutch performance.

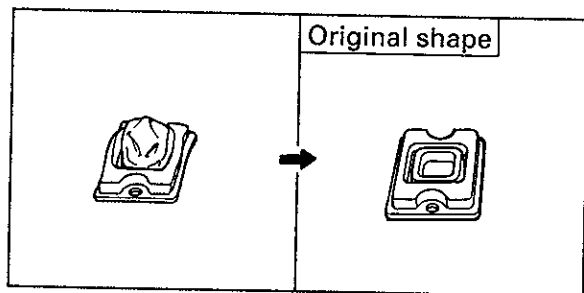

4. The diaphragm will lose its shape from the negative pressure if the brake fluid level goes down too far. Be sure to put the diaphragm back in its original shape before installing it into the master cylinder.

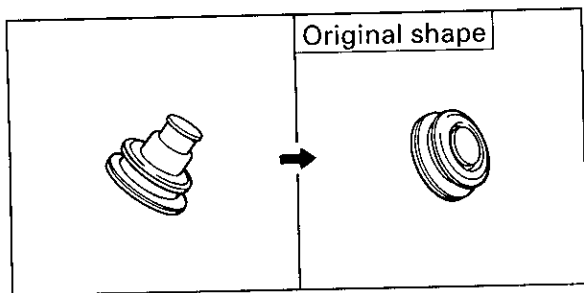

5. Be careful that water does not enter the master cylinder when refilling. Water will significantly lower the boiling point of the fluid and may result in vapor lock.

6. Brake fluid may deteriorate painted surfaces or plastic parts. Always clean up spilled fluid immediately.

EUU21400

NOTE: _____
As the brake pads wear, it is normal for the brake fluid level to gradually go down.

Brake fluid replacement

1. Complete fluid replacement should be done only by trained Yamaha service personnel.
2. Have a Yamaha dealer replace the following components during periodic maintenance or when they are damaged or leaking.
 - a. Replace all rubber seals every two years.
 - b. Replace all hoses every four years.

Drive chain slack check

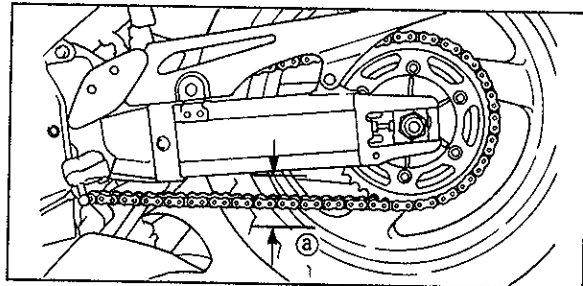

a Free play

NOTE:

Spin the wheel several times and find the tightest position of the chain. Check and/or adjust the chain slack while it's in this tightest position.

To check the chain slack the motorcycle must be held straight up with both wheels on the ground and without rider. Check the slack at the position shown in the illustration. Normal slack is approximately 20 ~ 35 mm. If the slack exceeds 35 mm, adjust.

Drive chain slack adjustment

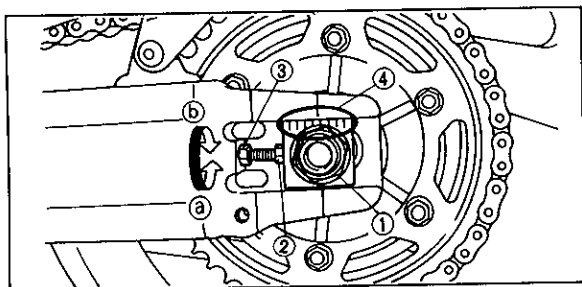

- 1 Axle nut
2 Adjusting bolt
3 Locknut
4 Alignment marks

1. Loosen the axle nut.
2. Loosen the locknuts on each side. To tighten the chain, turn the chain adjusting bolts in direction ①. To loosen the chain, turn the adjusting bolts in direction ② and push the wheel forward. Turn each adjusting bolt exactly the same amount to maintain correct axle alignment. There are marks on each side of the swingarm. Use these marks to align the rear wheel.

EUU33301

CAUTION:

Too little chain slack will overload the engine and other vital parts. Keep the slack within the specified limits.

3. After adjusting, tighten the locknuts. Then tighten the axle nut to the specified torque.

Tightening torque:

Axle nut:

150 Nm (15 m·kg)

Drive chain lubrication

The chain consists of many parts which work with each other. If the chain is not maintained properly, it will wear out quickly. Therefore, the chain must be serviced regularly. This service is especially necessary when riding in dusty areas. This motorcycle is equipped with a sealed type chain. Steam cleaning, high-pressure washes, and solvents can damage chain so do not use these for cleaning it. Use only kerosene to clean the drive chain. Wipe it dry, and thoroughly lubricate it with SAE 30 ~ 50W motor oil. Do not use any other lubricants on the drive chain. They may contain solvents that could damage the sealed chain.

EUV48300

CAUTION:

Be sure to oil the chain after washing the motorcycle or riding in the rain.

Cable inspection and lubrication

EUV64601

WARNING

Damage to the outer housing of cables may allow internal rusting and cause interference with cable movement. Replace damaged cables as soon as possible to prevent unsafe conditions.

Lubricate the inner cable and the cable end. If it does not operate smoothly, ask a Yamaha dealer to replace them.

Recommended lubricant:
SAE 10W30 motor oil

EAI30602

Brake and shift pedal lubrication

Lubricate the pivoting parts.

Recommended lubricant:
SAE 10W30 motor oil

EAI30701

Brake and clutch lever lubrication

Lubricate the pivoting parts.

Recommended lubricant:
SAE 10W30 motor oil

EAI31104

Sidestand lubrication

Lubricate the sidestand pivoting and mating parts. Check to see that the sidestand moves up and down smoothly.

Recommended lubricant:
SAE 10W30 motor oil

EUU70401

⚠ WARNING

**If the sidestand does not move smoothly,
consult a Yamaha dealer.**

EAI31901

Rear suspension lubrication

Lubricate the pivoting parts.

Recommended lubricant:
Molybdenum disulfide grease

Front fork inspection

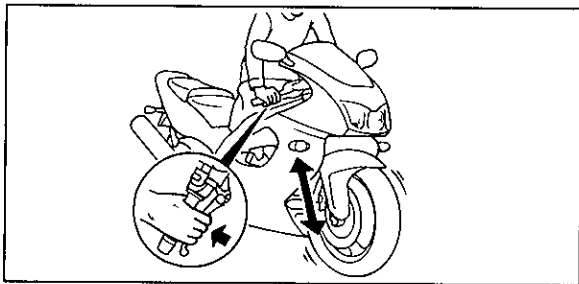

EUU65700

⚠ WARNING

5

Securely support the motorcycle so there is no danger of it falling over.

1. Visual check
Check for scratches or damage on the inner tube and excessive oil leakage from the front fork.
2. Operation check
Place the motorcycle on a level place.

- a. Hold the motorcycle in an upright position and apply the front brake.
- b. Push down hard on the handlebars several times and check if the fork rebounds smoothly.

EUU42500

CAUTION:

If any damage or unsmooth movement is found with the front fork, consult a Yamaha dealer.

Steering inspection

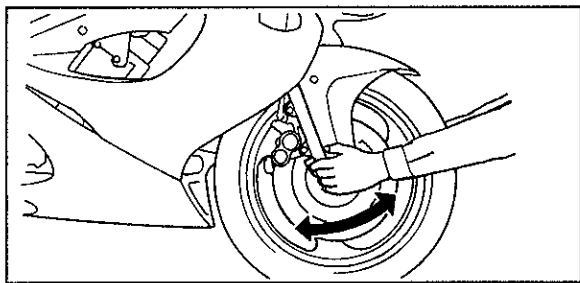

Periodically inspect the condition of the steering. Worn out or loose steering bearings may be dangerous. Place a stand under the engine to raise the front wheel off the ground. Hold the lower end of the front forks and try to move them forward and backward. If any free play can be felt, ask a Yamaha dealer to inspect and adjust the steering. Inspection is easier if the front wheel is removed.

EUU65700

! WARNING

Securely support the motorcycle so there is no danger of it falling over.

Wheel bearings

If there is play in the front or rear wheel hub or if the wheel does not turn smoothly, have a Yamaha dealer inspect the wheel bearings. The wheel bearings should be inspected according to the Maintenance Schedule.

Battery

This motorcycle is equipped with a sealed-type battery. Therefore it is not necessary to check the electrolyte or fill the battery with distilled water.

If the battery seems to have discharged, consult a Yamaha dealer.

EUU43401

CAUTION: _____

Do not try to remove the sealing caps of the battery cells. You may damage the battery.

⚠ WARNING

Battery electrolyte is poisonous and dangerous, causing severe burns, etc. It contains sulfuric acid. Avoid contact with skin, eyes or clothing.

Antidote:

EXTERNAL: Flush with water.

INTERNAL: Drink large quantities of water or milk. Follow with milk of magnesia, beaten egg, or vegetable oil. Call a physician immediately.

EYES: Flush with water for 15 minutes and get prompt medical attention. Batteries produce explosive gases. Keep sparks, flame, cigarettes etc., away. Ventilate when charging or using in an enclosed space. Always shield your eyes when working near batteries.

KEEP OUT OF REACH OF CHILDREN.

Storage

1. When the motorcycle is not used for a month or longer, remove the battery and store it in a cool, dark place. Completely recharge the battery before re-installation.

EUU43500

CAUTION

A special battery charger (constant voltage/ampere or constant voltage) is required for recharging the sealed type battery. Using a conventional battery charger may shorten the battery life.

2. Always make sure the connections are correct when putting the battery back in the motorcycle.

Fuse replacement

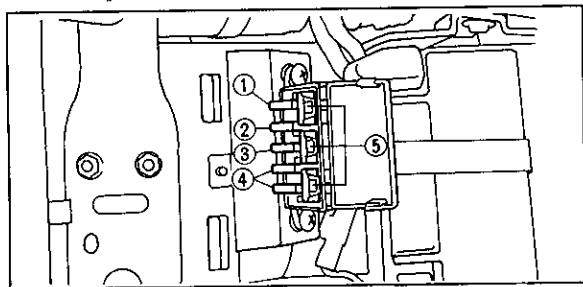

- | | |
|-------------------------|------------------|
| 1 Headlight fuse | 2 Ignition fuse |
| 3 Signaling system fuse | 4 Fan fuse (× 2) |
| 5 Spare fuse (× 3) | |

5

One fuse box is located under the rider's seat and the other is located behind cowl-
ing B (see page 5-7). If any fuse is blown,
turn off the main switch and the switch of
the circuit in question. Install a new fuse of
specified amperage. Turn on the switches
and see if the electrical device operates. If
the fuse immediately blows again, consult
a Yamaha dealer.

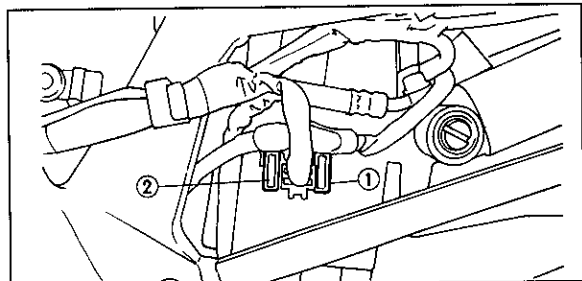

- | | |
|-------------|--------------|
| 1 Main fuse | 2 Spare fuse |
|-------------|--------------|

EUU34400

CAUTION:

Do not use fuses of higher amperage rating than those recommended. Substitution of a fuse of improper rating can cause extensive electrical system damage and possibly a fire.

Specified fuse:

Main:	30A
Head:	20A
Signaling system:	15A
Fan:	7.5A
Ignition:	15A

Headlight bulb replacement

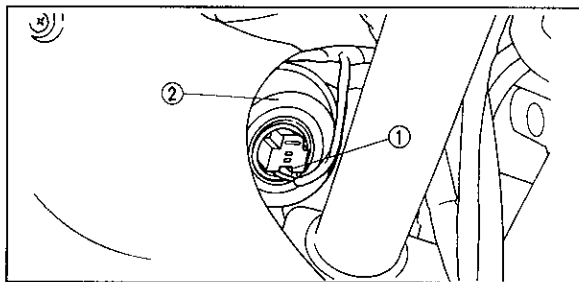

1 Headlight connector

2 Bulb holder cover

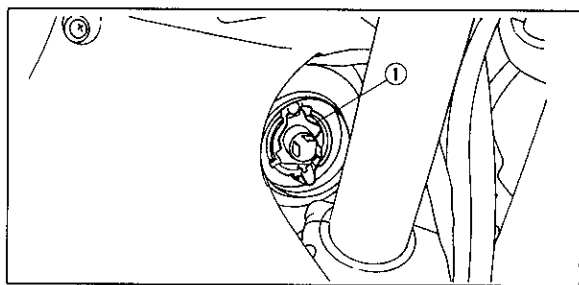

1 Bulb holder

This motorcycle is equipped with a quartz bulb headlight.

If a headlight bulb burns out, replace it as follows:

1. Remove the headlight connector and the bulb holder cover

2. Unhook the bulb holder and remove the defective bulb.

EUU66002

⚠ WARNING

Keep flammable products and your hands away from a bulb while it is on, as it is hot. Do not touch a bulb until it cools down.

3. Put a new bulb into position and secure it in place with the bulb holder.

EUU34101

CAUTION: _____

Avoid touching the glass part of a bulb. Keep it free from oil; otherwise, the transparency of the glass, life of the bulb, and luminous flux will be adversely affected. If oil gets on a bulb, thoroughly clean it with a cloth moistened with alcohol or lacquer thinner.

4. Install the bulb holder cover and the headlight connector.
If a headlight beam adjustment is necessary, ask a Yamaha dealer to make adjustment.

Troubleshooting

Although Yamaha motorcycles receive a rigid inspection before shipment from the factory, trouble may occur during operation.

Any problem in the fuel, compression, or ignition systems can cause poor starting and loss of power. The troubleshooting chart describes a quick, easy procedure for making checks.

If your motorcycle requires any repair, bring it to a Yamaha dealer. The skilled technicians at a Yamaha dealership have the tools, experience, and know-how to properly service your motorcycle. Use only genuine Yamaha parts on your motorcycle. Imitation parts may look like Yamaha parts, but they are often inferior. Consequently, they have a shorter service life and can lead to expensive repair bills.

Troubleshooting chart

⚠ WARNING

Never check the fuel system while smoking or in the vicinity of an open flame.

1 Fuel

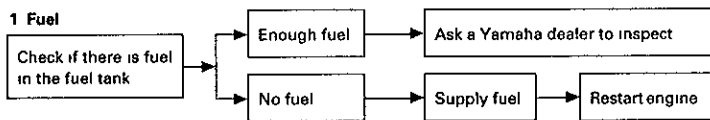

2. Compression

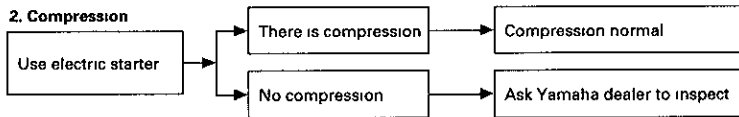

3 Ignition

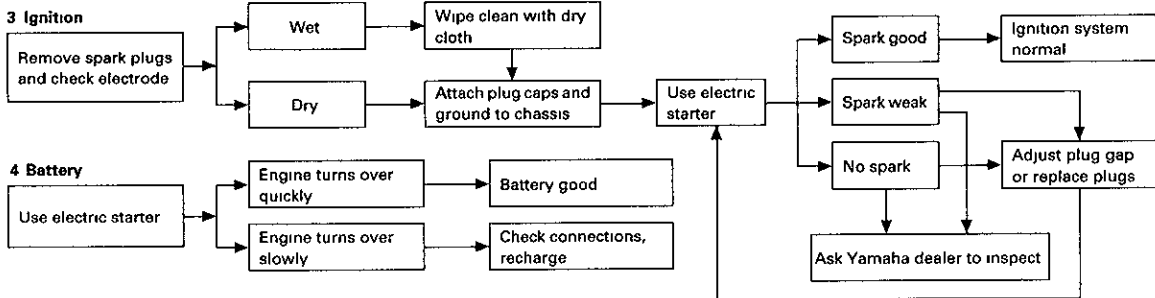

4 Battery

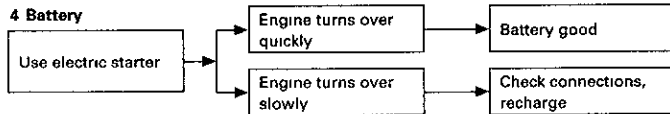

CLEANING AND STORAGE

A. Cleaning	6-1
B. Storage	6-3

A. CLEANING

Frequent, thorough cleaning of your motorcycle will not only enhance its appearance but will improve its general performance and extend the useful life of many components.

1. Before cleaning the motorcycle:
 - a. Block off the end of the exhaust pipe to prevent water entry. A plastic bag and strong rubber band may be used.
 - b. Make sure the spark plugs and all filler caps are properly installed.
2. If the engine case is excessively greasy, apply degreaser with a paint brush. Do not apply degreaser to the chain, sprockets or wheel axles.
3. Rinse the dirt and degreaser off with a garden hose. Use only enough pressure to do the job.

EUU34602

CAUTION

Excessive hose pressure may cause water seepage and deterioration of wheel bearings, front fork, brakes, transmission seals and electrical parts.

Many expensive repair bills have resulted from improper high pressure detergent applications such as those available in coin-operated car washers.

4. Once the majority of the dirt has been hosed off, wash all surfaces with warm water and mild, detergent-type soap. An old toothbrush or bottle brush is handy for hard-to-get-at places.
5. Rinse the motorcycle off immediately with clean water and dry all surfaces with a chamois, clean towel or soft absorbent cloth.

6. Dry the chain and lubricate it to prevent rust.
7. Windscreen cleaning

EUU37400

CAUTION

Avoid using any alkaline or strong acid cleaner, gasoline, brake fluid, or any other solvent.

Clean the windscreen with a cloth or sponge dampened with a neutral detergent, and after cleaning, thoroughly wash it off with water. Some cleaning compounds for plastics may leave scratches on surfaces of the windscreen. Before using them, make a test by polishing an area which does not affect your visibility.

8. Clean the seat with a vinyl upholstery cleaner to keep the cover pliable and glossy.
9. Automotive-type wax may be applied to all painted and chrome-plated surfaces. Avoid combination cleaner-waxes. Many contain abrasives which may mar the paint or protective finish on the fuel tank and side covers. When finished, start the engine and let it idle for several minutes.

CAUTION: _____

This model is equipped with an aluminum muffler that is finished with a clear protective coating. To protect the muffler from being scratched or damaged:

- **Wash the muffler when it is cool.**
 - **Use a household type detergent when washing. Using alkaline detergents may leave spots or stains on the muffler surface.**
 - **Do not use steel wool or materials of the like when washing.**
 - **Dry the muffler with a clean towel or soft absorbent cloth.**
 - **Do not use compounds or combination cleaner-waxes.**
-

B. STORAGE

Long term storage (60 days or more) of your motorcycle will require some preventive procedures to guard against deterioration. After thoroughly cleaning the motorcycle, prepare for storage as follows:

1. Drain the fuel tank, fuel lines and carburetor float bowls.
2. Remove the empty fuel tank, pour a cup of SAE 10W30 or 20W40 motor oil in the tank, shake the tank to coat the inner surfaces thoroughly and drain off the excess oil. Reinstall the tank.
3. Remove each spark plug, pour about one tablespoon of SAE 10W30 or 20W40 motor oil in each spark plug hole and reinstall the spark plugs. Turn the engine over several times (ground spark plug leads) to coat the cylinder walls with oil.

⚠ WARNING

When using the starter motor to crank the engine, remove the spark plug wires, and ground them to prevent sparking.

4. Clean the chain and lubricate it (refer to "Drive chain lubrication").
5. Lubricate all control cables.
6. Block up the frame to raise both wheels off the ground.
7. Tie a plastic bag over the exhaust pipe outlet to prevent moisture from entering.
8. If storing in a humid or salt-air atmosphere, coat all exposed metal surfaces with a light film of oil. Do not apply oil to any rubber parts or the seat cover

9. Remove the battery and charge it. Store it in a dry place and recharge it once a month. Do not store the battery in an excessively warm or cold place (less than 0°C or more than 30°C).

EUU05800

NOTE:

Make any necessary repairs before storing the motorcycle.

SPECIFICATIONS

SPECIFICATIONS..... 7-1

HOW TO USE THE CONVERSION

TABLE 7-6

SPECIFICATIONS

Model	YZF1000R
Dimensions	
Overall length	2,085 mm
Overall width	740 mm
Overall height	1,175 mm
Seat height	815 mm
Wheelbase	1,430 mm
Minimum ground clearance	140 mm
Minimum turning radius	3,100 mm
Basic weight:	
With oil and full fuel tank	224 kg
Engine.	
Engine type	Liquid-cooled 4-stroke, DOHC
Cylinder arrangement	Forward-inclined parallel 4-cylinder
Displacement	1,003 cm ³
Bore × stroke	75.5 × 56.0 mm
Compression ratio	11.5:1
Starting system	Electric starter
Lubrication system	Wet sump

Model	YZF1000R
Oil type or grade Engine oil	Refer to page 3-5.
Oil capacity: Engine oil Periodic oil change With oil filter replacement Total amount	3 0 L 3 2 L 3 5 L
Radiator capacity (including all routes).	2.7 L
Air filter.	Dry type element
Fuel: Type Fuel tank capacity Fuel reserve amount	Regular gasoline Unleaded fuel only (For Australia) 20 L 4.5 L
Carburetor. Type / quantity Manufacturer	BDSR38/4 MIKUNI

Model	YZF1000R					
Spark plug Type Manufacturer Spark plug gap Clutch type	DR8EA/X24ESR-U NGK/NIPPONDENSO 0.6 ~ 0.7 mm Wet, multiple-disc					
Transmission: Primary reduction system Primary reduction ratio Secondary reduction system Secondary reduction ratio Transmission type Operation Gear ratio <table data-bbox="568 560 618 731" style="margin-left: 200px;"> <tr><td>1st</td></tr> <tr><td>2nd</td></tr> <tr><td>3rd</td></tr> <tr><td>4th</td></tr> <tr><td>5th</td></tr> </table>	1st	2nd	3rd	4th	5th	Spur gear 68/41 (1.659) Chain drive 46/17 (2.706) Constant mesh 5-speed Left foot operation 36/14 (2.571) 32/18 (1.778) 29/21 (1.381) 27/23 (1.174) 28/27 (1.037)
1st						
2nd						
3rd						
4th						
5th						
Chassis: Frame type Caster angle Trail	Diamond 24° 97 mm					

Model	YZF1000R
Tire: Type Size (front) (rear)	Tubeless 120/70 ZR17 180/55 ZR17
Brake: Front brake type operation Rear brake type operation	Dual disc brake Right hand operation Single disc brake Right foot operation
Suspension: Front suspension Rear suspension	Telescopic fork Swingarm (link suspension)
Shock absorber: Front shock absorber Rear shock absorber	Coil spring / Oil damper Coil spring / Gas-oil damper
Wheel travel: Front wheel travel Rear wheel travel	120 mm 120 mm

Model	YZF1000R
Electrical. Ignition system Generator system Battery type Battery capacity	T C I. (Digital) A C generator YTX14-BS 12 V 12 AH
Headlight type	Quartz bulb (Halogen)
Bulb wattage × quantity Headlight Tail / brake light Flasher light Meter light Neutral indicator light High beam indicator light Oil level indicator light Turn indicator light Fuel indicator light	12 V 60 W / 55 W × 2 12 V 5 W / 21 W × 2 12 V 21 W × 4 12 V 17 W × 4 12 V 3.4 W × 1 12 V 3.4 W × 1 12 V 3.4 W × 1 12 V 3.4 W × 1 12 V 3.4 W × 1

HOW TO USE THE CONVERSION TABLE

All specification data in this manual are listed in SI and METRIC UNITS.

Use this table to convert METRIC unit data to IMPERIAL unit data.

Ex.

METRIC		MULTIPLIER	=	IMPERIAL
**mm	×	0.03937	=	**in
2 mm	×	0.03937	=	0.08 in

CONVERSION TABLE

METRIC TO IMPERIAL			
	Metric unit	Multiplier	Imperial unit
Torque	m·kg	7 233	ft lb
	m kg	86.794	in lb
	cm kg	0.0723	ft lb
	cm kg	0.8679	in·lb
Weight	kg	2 205	lb
	g	0.03527	oz
Speed	km/hr	0 6214	mph
Distance	km	0 6214	mi
	m	3.281	ft
	m	1.094	yd
	cm	0 3937	in
	mm	0.03937	in
Volume / Capacity	cc (cm ³)	0.03527	oz (IMP liq.)
	cc (cm ³)	0 06102	cu in
	lt (liter)	0 8799	qt (IMP liq.)
	lt (liter)	0 2199	gal (IMP liq.)
Misc.	kg/mm	55 997	lb/in
	kg/cm ²	14 2234	psi (lb/in ²)
	Centigrade (°C)	9/5 + 32	Fahrenheit (°F)

NOISE REGULATION (FOR Australia)

NOISE REGULATION (FOR Australia)	8-1
---	-----

NOISE REGULATION (FOR Australia)

“TAMPERING WITH NOISE CONTROL SYSTEM PROHIBITED”

Owners are warned that the law may prohibit:

- (a) The removal or rendering inoperative by any person other than for purposes of maintenance, repair or replacement, of any device or element of design incorporated into any new vehicle for the purpose of noise control prior to its sale or delivery to the ultimate purchaser or while it is in use; and
- (b) the use of the vehicle after such device or element of design has been removed or rendered inoperative by any person.

PRINTED ON RECYCLED PAPER

YAMAHA
YAMAHA MOTOR CO., LTD

PRINTED IN JAPAN
96 4 - 0 3 × 1 CR
(英)