



Motorcycle Owner's Manual

KX65

Quick Reference Guide

This Quick Reference Guide will assist you in finding the information you're looking for.

GENERAL INFORMATION

MAINTENANCE AND ADJUSTMENT

TROUBLESHOOTING GUIDE

TUNING

STORAGE

A Table of Contents is included after the Foreword.

IMPORTANT INFORMATION

- This vehicle is designed for the operator only, no passengers.
- This vehicle is a competition model only and was not manufactured for use on public streets, roads or highways.
- The use of this vehicle should be limited to participation in sanctioned competition events upon a closed course.
- This vehicle should not be used for general off-load recreation riding.
- Read owner's manual.

Whenever you see the symbols shown below, heed their instructions! Always follow safe operating and maintenance practices.

 **DANGER**

DANGER indicates a hazardous situation which, if not avoided, will result in death or serious injury.

 **WARNING**

WARNING indicates a hazardous situation which, if not avoided, could result in death or serious injury.

NOTICE

NOTICE is used to address practices not related to personal injury.

NOTE

○ *NOTE* indicates information that may help or guide you in the operation or service of the vehicle.

IMPORTANT NOTICE

THIS VEHICLE IS A COMPETITION MODEL ONLY AND WAS NOT MANUFACTURED FOR, NOR SHOULD IT BE USED ON, PUBLIC STREETS, ROADS, OR HIGHWAYS. THE USE OF THIS VEHICLE SHOULD BE LIMITED TO PARTICIPATION IN SANCTIONED COMPETITION EVENTS UPON A CLOSED COURSE. THIS VEHICLE SHOULD NOT BE USED FOR GENERAL OFF-ROAD RECREATIONAL RIDING. READ OWNER'S MANUAL.

 **WARNING**

THIS VEHICLE SHOULD NOT BE USED FOR GENERAL OFF-ROAD RECREATIONAL RIDING.

Disclaimer of Warranty

This motorcycle is sold AS IS, with all faults, obvious or concealed and there are NO WARRANTIES, expressed or implied. Including warranties of MERCHANTABILITY or FITNESS FOR PURPOSE.

The purchaser accepts all responsibilities concerning quality, performance, cost of service and/or necessary repairs.

Motorcycle Noise Emission Control
Information

This motorcycle is designed for closed course competition use only. It does not conform to U.S. EPA motorcycle noise standards.

NOTICE

Off-road motorcycling is a wonderful sport, and we hope you will enjoy it to the fullest. However, if improperly conducted, this sport has the potential to cause environmental problems as well as conflicts with other people. Responsible use of your off-road motorcycle will ensure that these problems and conflicts do not occur. TO PROTECT THE FUTURE OF YOUR SPORT, MAKE SURE YOU USE YOUR MOTORCYCLE LEGALLY, SHOW CONCERN FOR THE ENVIRONMENT, AND RESPECT THE RIGHTS OF OTHER PEOPLE.

 WARNING

The engine exhaust from this product contains chemicals known to the State of California to cause cancer, birth defects or other reproductive harm.

FOREWORD

Congratulations on choosing this Kawasaki motorcycle. Your new motorcycle is the product of Kawasaki's advanced engineering, exhaustive testing, and continuous striving for a superior lightweight, high-performance machine with superb handling and stability for racing and sporting use.

Your new KX is a highly tuned competition machine for participation in racing events. As with any mechanical device, proper care and maintenance are important for trouble-free operation and top performance. This manual is written to enable you to keep your KX properly tuned and adjusted.

Due to improvements in design and performance made during production, in some cases there may be minor discrepancies between the actual vehicle and the illustrations and text in this manual.

**KAWASAKI HEAVY INDUSTRIES, LTD.,
Motorcycle & Engine Company**

© 2013 Kawasaki Heavy Industries, Ltd.

Mar. 1, 2013. (1)

IMPORTANT NOTE TO PARENTS ABOUT SAFE RIDING

This is a high performance off-road motorcycle designed for experienced young riders. It is not suitable for beginners. Your youngster's safety will depend on your commitment to always provide a safe riding environment and a properly maintained vehicle. As with any moving vehicle there are possible safety risks; be sure to heed these precautions.

1. Always equip your child with suitable protective gear and riding apparel. Be sure he or she always wears a helmet, eye protection, gloves, long pants, and a long-sleeved shirt while riding.
2. Never allow your child to carry a passenger. This motorcycle is designed for an OPERATOR ONLY.
3. This motorcycle is designed for off-road riding and should never be operated on public roads or paved surfaces.
4. Always obey local off-road riding laws and regulations. Obtain permission to ride on private property.
5. You, the parent (and most likely "riding instructor/mechanic" as well), must be familiar with motorcycle controls and maintenance requirements plus riding techniques. Read and understand the owner's manual provided with the motorcycle. Review all instructions and warnings with your child.
6. You must determine your child's readiness to ride this off-road motorcycle. Your child should already be familiar with motorcycle controls (location and function) and basic riding techniques. Your child should also be physically large and strong enough to be able to straddle the motorcycle and hold it up, plus be able to pick it up if it is on its side.
7. Before allowing your child to enter competition events, you must determine that he or she has the necessary riding skills and physical/emotional maturity.
8. Your child's safety depends in part on the good mechanical condition of the motorcycle. Be sure to follow the maintenance and adjustment requirements contained in the Periodic Maintenance Chart, Daily Pre-ride Inspection, and After-Race Check Points. Be sure your child understands the importance of checking all items thoroughly before riding the motorcycle. Also, familiarity with the motorcycle is important should a problem occur far from help.
9. Do not allow your child to ride unsupervised. He or she should always ride in the company of an experienced adult.
10. Encourage your child not to ride beyond his or her skill level or faster than conditions safely allow. Have them practice advanced riding maneuvers under controlled conditions.
11. Tell someone where you and your child are planning to ride and when you intend to return. Discuss the ride with your child before you leave so he or she will know in advance what riding techniques may be necessary to negotiate the terrain safely. If you are not familiar with the area, lead the way and reduce your speed.

This motorcycle is designed for a rider weighting less than 55 kg (121 ponds).
Exceeding this limit could damage the motorcycle.

TABLE OF CONTENTS

SPECIFICATIONS	10	Exhaust System	72
GENERAL INFORMATION	13	Drive Chain.....	74
Location of Labels	13	Handlebar	80
Location of Parts	17	Brakes	81
Side Stand	20	Steering	85
Fuel	20	Front Fork.....	86
Kick Pedal	24	Rear Suspension (UNI-TRAK®).....	92
Starting the Engine.....	24	Wheels	95
Shifting Gears.....	25	Tightening Torques of Nuts and Bolts.....	99
Stopping the Motorcycle.....	26	Cleaning Your Motorcycle.....	103
Stopping the Engine	27	Lubrication	105
Break-In.....	27	TROUBLESHOOTING GUIDE	108
Daily Pre-Ride Checks	29	TUNING	114
After-Race Checks	31	Carburetor Tuning	114
MAINTENANCE AND ADJUSTMENT	32	Suspension Tuning.....	121
Periodic Maintenance Chart.....	32	Gearing.....	126
Transmission Oil.....	36	Special Care According to Track Conditions .	127
Cooling System	38	OPTIONAL PARTS	128
Spark Plug.....	43	PRE-RACE CHECKS AND AFTER-RACE	
Ignition Timing	44	MAINTENANCE	129
Air Cleaner	46	STORAGE	131
Throttle Cable.....	49	Before Storage	131
Carburetor	51	After Storage	132
Clutch	52	ENVIRONMENTAL PROTECTION	133
Piston	62	WIRING DIAGRAM	134

SPECIFICATIONS

DIMENSIONS

Overall Length	1 590 mm (62.6 in.)
Overall Width	760 mm (29.9 in.)
Overall Height	955 mm (37.6 in.)
Wheelbase	1 120 mm (44.1 in.)
Ground Clearance	305 mm (12.0 in.)
Curb Mass	60 kg (132.3 lb)
Fuel Tank Capacity	3.8 L (1.0 US gal)

ENGINE

Type	2-stroke, single-cylinder, piston reed valve, liquid-cooled		
Bore × Stroke	44.5 × 41.6 mm (1.75 × 1.64 in.)		
Displacement	64 cm ³ (3.91 cu in.)		
Compression Ratio:	8.4 : 1		
Timing:	Intake port:	Open	Full Open
		Closed	–
	Scavenging port:	Open	61.8° BBDC
		Closed	61.8° ABDC
	Exhaust port:	Open	91.5° BBDC
		Closed	91.5° ABDC
Carburetor	MIKUNI VM24SS		

Lubrication System	PETROL MIX (32 : 1)
Starting System	Primary Kick
Ignition System	CDI
Ignition Timing	20.5° BTDC @7 100 r/min (rpm)
Spark Plug	NGK BR10EG
Spark Plug Terminal	Solid-Post

TRANSMISSION

Transmission Type	6-speed, Constant Mesh, Return Shift
Clutch Type	Wet, Multi Disc
Drive system	Chain Drive
Gear Ratios:	1st Gear 2.846 (37/13)
	2nd Gear 2.125 (34/16)
	3rd Gear 1.722 (31/18)
	4th Gear 1.428 (30/21)
	5th Gear 1.217 (28/23)
	6th Gear 1.083 (26/24)
Primary Reduction Ratio	3.500 (77/22)
Final Reduction Ratio	3.615 (47/13)
Overall Ratio (Top Gear)	13.703
Transmission Oil:	Capacity 0.5 L (0.53 US qt)
	Type API SG, SH, SJ, SL or SM with JASO MA, MA1 or MA2
	SAE 10W-40

12 SPECIFICATIONS

FRAME

Type		Tubular, semi-double cradle
Steering Angle		40° to Either Side
Castor		27°
Trail		60 mm (2.36 in.)
Tire Size, Type:	Front	60/100-14 30M, DUNLOP D756F
	Rear	80/100-12 41M, DUNLOP D756
Rim Size:	Front	14 × 1.40
	Rear	12 × 1.60
Suspension:	Front	Telescopic fork
	Rear	UNI-TRAK® Swingarm
Front Suspension Travel		210 mm (8.27 in.)
Rear Wheel Travel		240 mm (9.45 in.)
Front Fork Oil	Type	Kawasaki Fork Oil SS8
	Amount (per fork leg)	249.5 ~ 254.5 mL (8.44 ~ 8.60 US oz)
	Level (fork compressed, spring removed)	132 mm (5.2 in.)

BRAKES

Type	(Front & Rear)	Disc
Effective Disc Diameter:	Front	154.8 mm (6.09 in.)
	Rear	146 mm (5.75 in.)

Specifications are subject to change without notice.

GENERAL INFORMATION

Location of Labels

All warning labels which are on your vehicle are repeated here. Read labels on your vehicle and understand them thoroughly. They contain information which is important for your safety and the safety of anyone else who may operate your vehicle. Therefore, it is very important that all warning labels be on your vehicle in the locations shown. If any label is missing, damaged, or worn, get a replacement from your Kawasaki dealer and install it in the correct position.

NOTE

- *The sample warning labels in this section have part numbers to help you and your dealer obtain the correct replacement.*

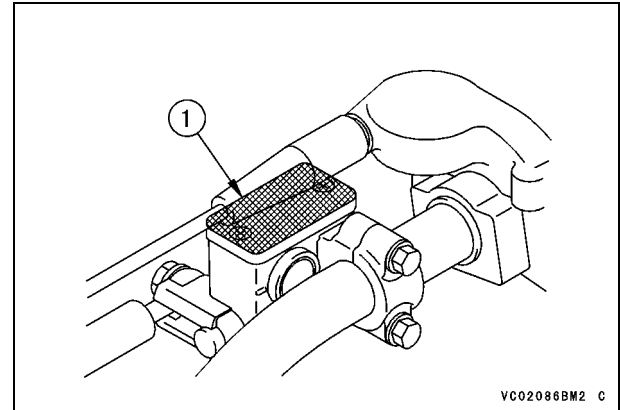

1. Brake Fluid (Front)

14 GENERAL INFORMATION

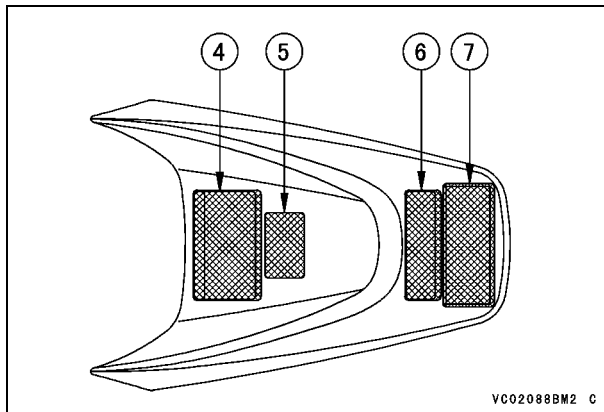
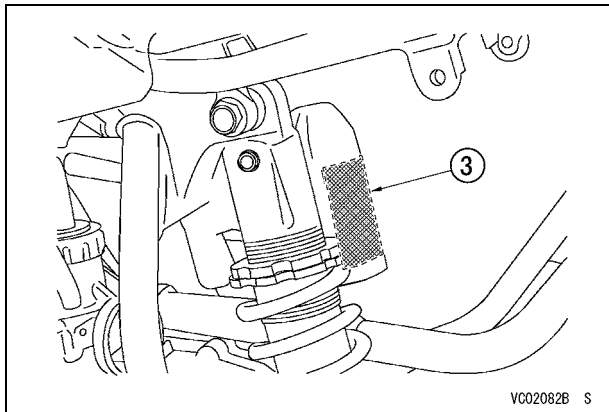
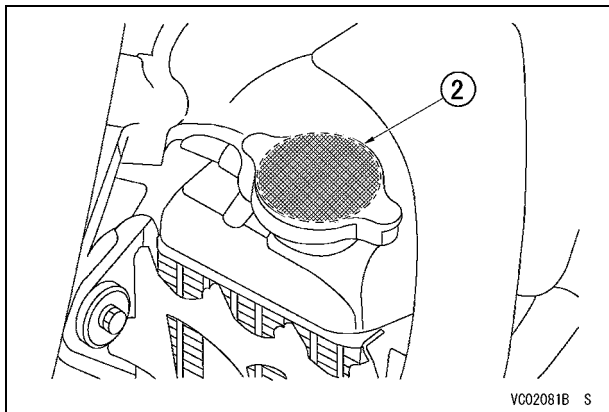

- 2. Radiator Cap Danger
- 3. Rear Shock Absorber Warning
- 4. Disclaimer of Warranty
- 5. Gasoline-Engine Oil Mixing Ratio
- 6. Noise Emission Control Information
- 7. Important Information

1)

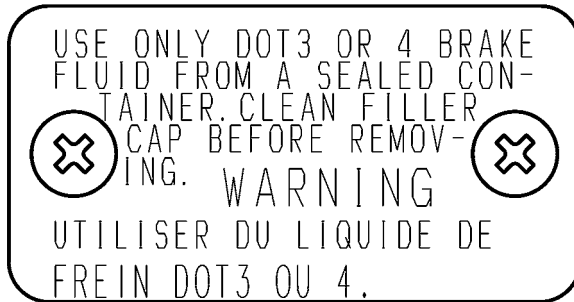

VC02074B S

3)

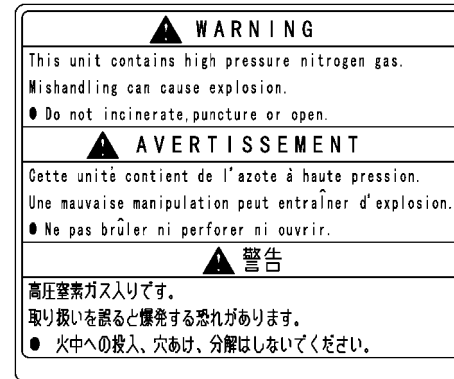

BD032380M2 C

2)

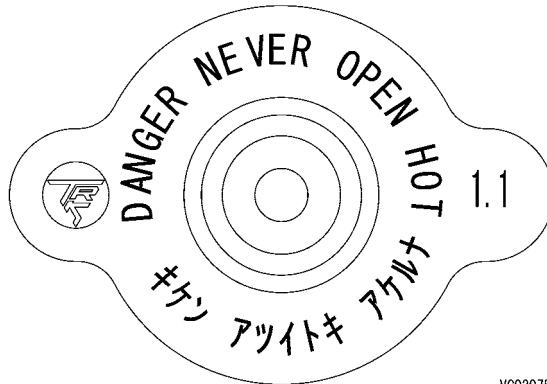

VC02075B S

4)

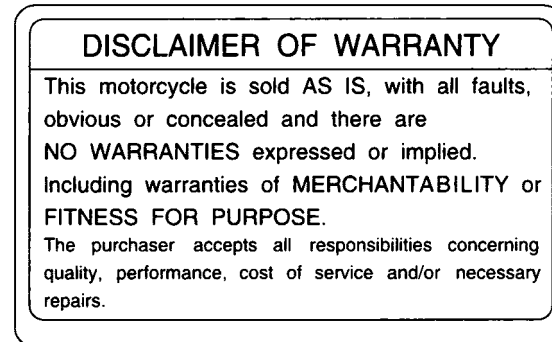

56030-1229

VC02092B S

16 GENERAL INFORMATION

5)

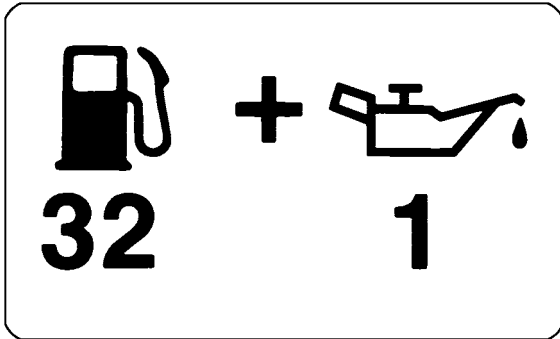

56030-1230

VC02093B S

6)

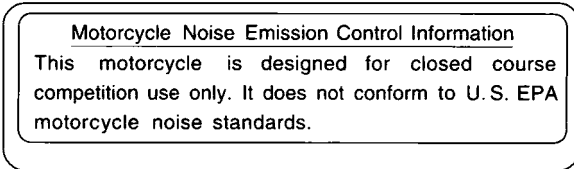

56030-1231

VC02094B S

7)

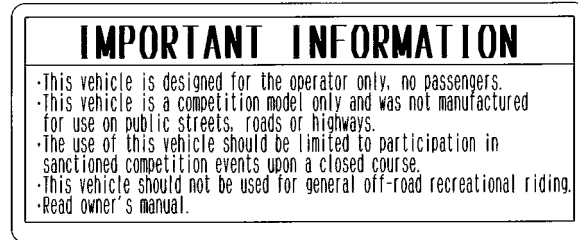

56071-0028

VC02076B S

Location of Parts

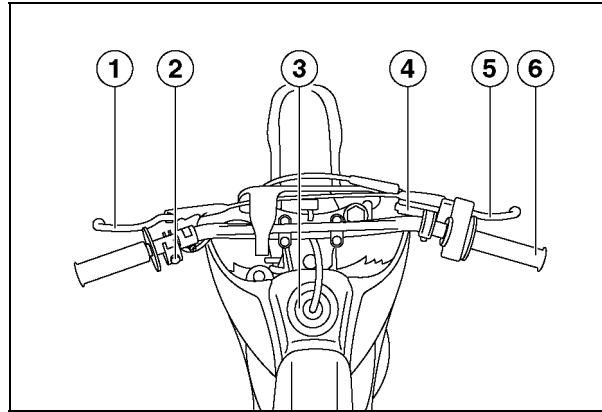

1. Clutch Lever
2. Engine Stop Button
3. Fuel Tank Cap
4. Front Brake Fluid Reservoir
5. Front Brake Lever
6. Throttle Grip

18 GENERAL INFORMATION

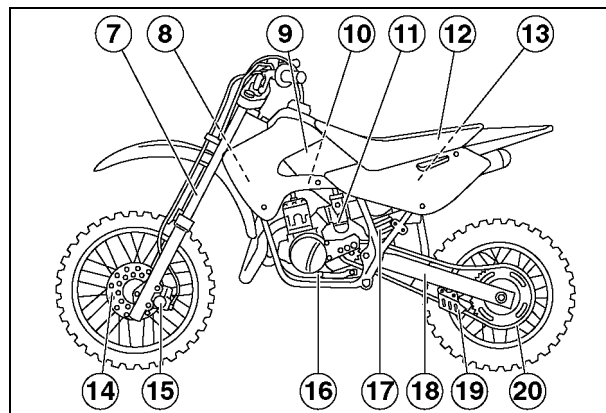

- 7. Front Fork
- 8. Radiator
- 9. Fuel Tank
- 10. Fuel Tap
- 11. Carburetor
- 12. Seat
- 13. Air Cleaner Element
- 14. Brake Disc
- 15. Brake Caliper
- 16. Shift Pedal
- 17. Rear Shock Absorber
- 18. Swingarm
- 19. Chain Guide
- 20. Drive Chain

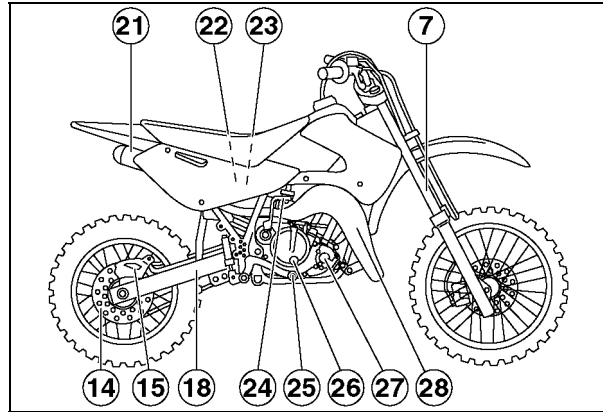

- 21. Muffler
- 22. Rear Brake Fluid Reservoir
- 23. Rear Shock Absorber Gas Reservoir
- 24. Kick Pedal
- 25. Rear Brake Pedal
- 26. Transmission Oil Level Inspection Window
- 27. Water Pump Cover
- 28. Exhaust Pipe

20 GENERAL INFORMATION

Side Stand

Support the motorcycle with the provided side stand as shown.

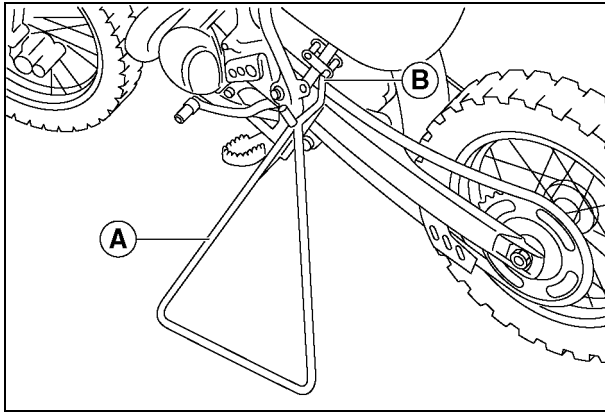

- A. Side Stand
- B. Longer end

⚠ WARNING

Riding with the side stand in the down position can cause a crash resulting in injury. Do not start the engine or attempt to ride the motorcycle when the side stand is down.

NOTE

- Support the motorcycle by using the suitable stand when performing the maintenance or adjustment.

Fuel

The Kawasaki KX is equipped with a 2-stroke engine that requires a gasoline-oil mixture.

Fuel Tank Capacity	3.8 liters (1.0 US gal)
--------------------	-------------------------

To open the fuel tank cap, disconnect the breather hose from the hole in the number plate, and turn the tank cap counterclockwise.

The breather hose has the check valve. The check valve on the breather hose prevents fuel from flowing out. When installing the breather hose, make sure the arrow on the valve points toward the fuel tank cap.

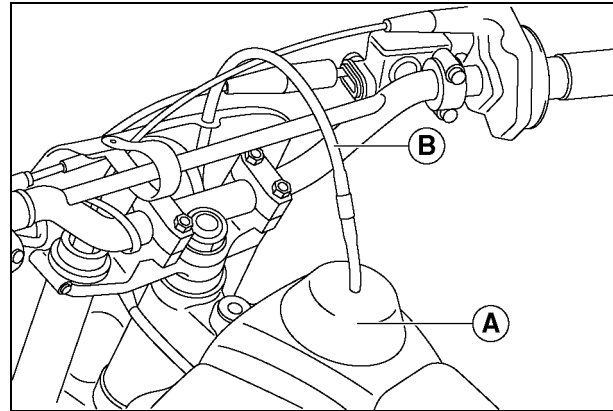

- A. Fuel Tank Cap
- B. Breather Hose

⚠ WARNING

Gasoline is extremely flammable and can be explosive under certain conditions, creating the potential for serious burns. Always stop the engine and never smoke while handling fuel. Make sure the area is well-ventilated and free from any source of flame or sparks; this includes any appliance with a pilot light. Make sure the engine is cold before working. Wipe any fuel off the engine before starting it. Gasoline is a toxic substance. Dispose of gasoline properly. Contact your local authorities for approved disposal methods.

NOTICE

If engine “knocking” or “pinging” occurs, use a different brand of gasoline of a higher octane rating.
If this condition is allowed to continue it can lead to severe engine damage.
Gasoline quality is important. Fuels of low quality or not meeting standard industry specifications may result in unsatisfactory performance. Operating problems that result from the use of poor quality or nonrecommended fuel may not be covered under your warranty.

Fuel Requirements:*Fuel Type*

Use clean, fresh unleaded gasoline with a minimum Antiknock index of 90. The Antiknock Index is posted on service station pumps in the U.S.A. The octane rating of a gasoline is a measure of its resistance to detonation or “knocking.” The Antiknock Index is an average of the Research Octane Number (RON) and the Motor Octane Number (MON) as shown in the table below.

Octane Rating Method	Minimum Rating
Antiknock Index $\frac{(\text{RON} + \text{MON})}{2}$	90

Fuels Containing Oxygenates

Gasoline frequently contains oxygenates (alcohols and ethers) especially in areas of the U.S. and Canada which are required to sell such reformulated fuels as part of a strategy to reduce exhaust emissions.

The types and volume of fuel oxygenates approved for use in unleaded gasoline by the U.S. Environmental Protection Agency include a broad range of alcohols and ethers, but only two components have seen any significant level of commercial use.

Gasoline/Alcohol Blends - Gasoline containing up to 10% ethanol (alcohol produced from agricultural products such as corn), also known as “gasohol” is approved for use.

22 GENERAL INFORMATION

NOTICE

Avoid using blends of unleaded gasoline and methanol (wood alcohol) whenever possible, and never use “gasohol” containing more than 5% methanol. Fuel system damage and performance problems may result.

Gasoline/Ether Blends - The most common ether is methyl tertiary butyl ether (MTBE). You may use gasoline containing up to 15% MTBE.

NOTE

- *Other oxygenates approved for use in unleaded gasoline include TAME (up to 16.7 %) and ETBE (up to 17.2 %). Fuel containing these oxygenates can also be used in your Kawasaki.*

NOTICE

Never use gasoline with an octane rating lower than the minimum specified by Kawasaki.

Never use “gasohol” with more than 10% ethanol, or more than 5% methanol. Gasoline containing methanol must also be blended with cosolvents and corrosion inhibitors.

Certain ingredients of gasoline may cause paint fading or damage. Be extra careful not to spill gasoline or gasoline oxygenate blends during refueling.

When not operating your Kawasaki for 30 to 60 days, mix a fuel stabilizer (such as STA-BIL) with the gasoline in the fuel tank. Fuel stabilizer additives inhibit oxydation of the fuel which minimizes gummy deposits.

Never store this product with “gasohol” in the fuel system. Before storage it is recommended that you drain all fuel from the fuel tank and carburetors. See the Storage section in this manual.

Two-Stroke Engine Oil

Oil must be mixed with the gasoline to lubricate the piston, cylinder, crankshaft, bearings, and connecting rod bearings.

NOTE

- *If unavailable, use an equivalent type of two stroke racing oil.*

Recommended Oil

Kawasaki Performance 2-Stroke Racing Oil*
or equivalent 2-stroke engine lubricant

*Kawasaki Performance Oils and Lubricants have been specifically engineered for your vehicle. Consistent use of these products meets or exceeds warranty and service requirements and can help to extend the life of your Kawasaki.

Gasoline-Engine Oil Mixing Ratio

32 : 1 (gasoline: engine oil)

A 32-to-1 mixture is about 31 mL of oil per liter of gasoline or 4 fluid ounces of oil per gallon of gasoline.

NOTICE

Do not use vegetable and mineral oils. Too much oil will cause excessive smoking and spark plug fouling. Too little oil will cause engine damage or premature wear.

To prepare the gasoline-oil mixture, pour the oil and half of the gasoline into a container first and stir thoroughly. Then, add the rest of the gasoline and stir the mixture well.

NOTE

- *At low temperature, oil will not easily mix with gasoline. Take time to ensure a well-blended mixture.*
- *The lubricative quality of the gasoline-oil mixture deteriorates rapidly; therefore, prepare a fresh mixture for each day of operation.*

24 GENERAL INFORMATION

Kick Pedal

This motorcycle starting system is primary kick. When the clutch lever is pulled, the motorcycle can be started with the transmission in any gear.

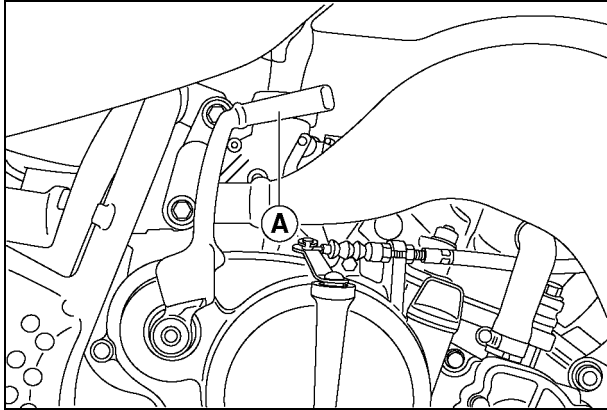

A. Kick Pedal

Starting the Engine

- Turn the fuel tap lever to the ON position.

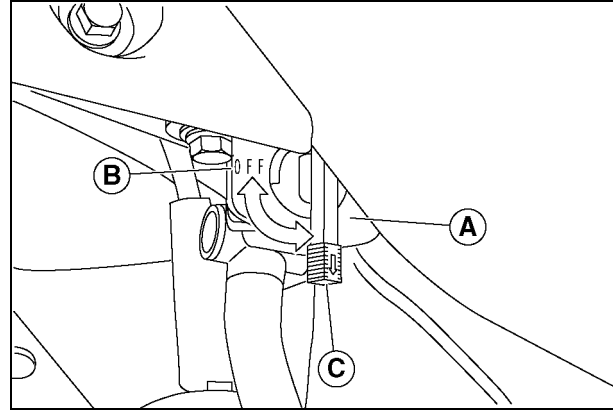

- A. Fuel Tap
- B. OFF position
- C. ON position

- Make sure the transmission is in neutral.
- If the engine is cold, pull up the choke knob.
- Kick the engine over, leaving the throttle closed.

⚠ WARNING

Riding with the side stand in the down position can cause a crash resulting in injury. Do not start the engine or attempt to ride the motorcycle when the side stand is down.

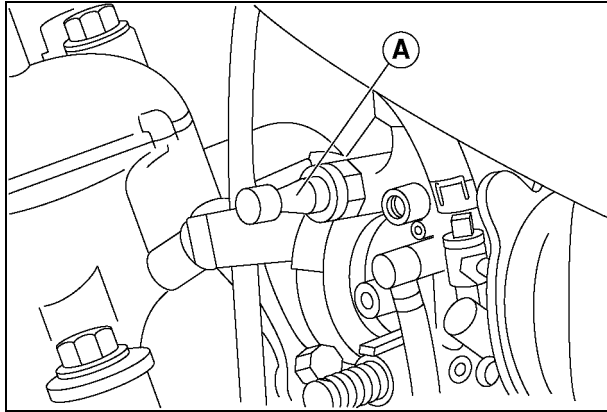

A. Choke Knob

- Even after the engine has started, do not push back the choke knob until the engine is thoroughly warmed up.

NOTE

- *When the engine is already warm or on hot days, open the throttle part way instead of using the choke knob.*
- *If the engine is flooded, kick it over with the throttle fully open until it starts.*
- *When the clutch lever is pulled, the motorcycle can be started with the transmission in any gear.*

Shifting Gears

This motorcycle is equipped with a 6-speed “return shift” transmission. The neutral is located halfway between 1st and 2nd gear. “Return shift” means that when shifting up or down, each gear must be engaged before the next higher or lower gear may be selected.

- To engage first gear from the neutral position, pull in the clutch lever and push down on the shift pedal, gently release the clutch lever, then release the shift pedal.
- To shift up to the next gear, pull in the clutch lever, lift the shift pedal with your toes, gently release the clutch lever, and then release the shift pedal.
- To shift down to the next gear, pull in the clutch lever, push the shift pedal down as far as it will go, gently release the clutch lever, then release the shift pedal.

NOTICE

When changing gears, press firmly on the shift pedal to ensure proper shifting. Careless, incomplete shifting can cause the transmission to jump out of gear and lead to engine damage.

26 GENERAL INFORMATION

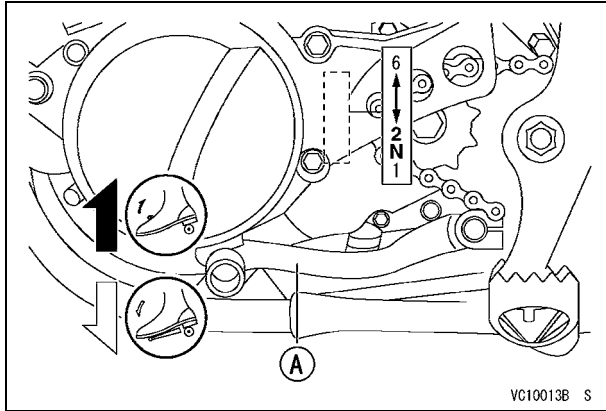

A. Shift Pedal

Stopping the Motorcycle

For maximum deceleration, close the throttle and apply both front and rear brakes. Pull in the clutch lever as the motorcycle comes to a stop. Independent use of the front or rear brake may be advantageous in certain circumstances. Shift down progressively to ensure good engine response at all speeds.

Stopping the Engine

- Shift the transmission into the neutral position.
- After racing the engine slightly, close the throttle completely and push the engine stop button.

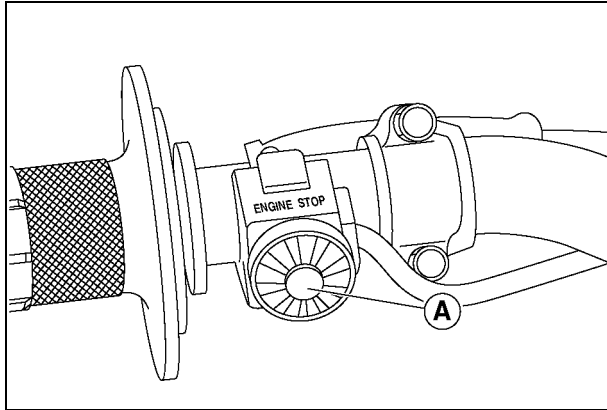

A. Engine Stop Button

- Turn the fuel tap lever to the OFF position.

Break-In

A brief break-in procedure must be carried out to obtain the proper operating clearances in the engine and transmission, which are necessary for performance and reliability.

NOTICE

For the first hour or 20 km (12 mi) of operation, run the engine at low and moderate engine speeds. See details below.

NOTE

- *The low-speed operation during the break-in period may cause carbon to build up on and foul the spark plug. If so, replace the standard spark plug with a hotter spark plug for the duration of the break-in period.*

Recommended Spark Plug

Standard Plug	NGK BR10EG
Hotter Plug	NGK BR9EG

Break in the engine as follows.

1. Start the engine and let it idle until it is thoroughly warmed up.
2. Stop and let the engine cool completely.
3. Start the engine and ride the motorcycle for 10 minutes at moderate speed - **NEVER ACCELERATE HARD.**

28 GENERAL INFORMATION

4. Stop and let the engine cool completely. Be sure to check and adjust the chain slack and spoke tightness and carry out a general inspection.
5. Start the engine and ride the motorcycle for 20 minutes at moderate speed -**NEVER ACCELERATE HARD.**
6. Stop and let the engine cool completely. Check and adjust as in step 4. Then, drain the coolant, remove and inspect the cylinder head, cylinder and piston.

Piston: A scored piston skirt could lower engine performance or damage the cylinder wall. Scores on the cylinder wall should be smoothed with a **#400 to #600** emery cloth.

Cylinder: Decarbonize the exhaust ports and the upper part of the cylinder, taking care not to damage the cylinder wall. Scores on the cylinder wall should be smoothed with a **#400 to #600** emery cloth.

Cylinder Head: Remove the carbon inside the combustion chamber.

7. Install the parts removed.
8. Fill the radiator up to the bottom of the radiator filler neck with coolant. Before putting the motorcycle into operation, bleed the cooling system.
9. Start the engine and ride the motorcycle for 30 minutes at moderate speed-**NEVER ACCELERATE HARD.**
10. Stop and let the engine cool completely. Check and adjust as in step 4.
11. After the break-in procedure has been properly carried out, the motorcycle is ready for regular operation. Using the proper riding skills and techniques and avoiding recklessly high engine speeds will keep the engine trouble-free.

NOTE

- *After break-in, install a new standard spark plug, and change the transmission oil.*
- *To keep optimum engine performance, replace the piston rings after break-in.*

Daily Pre-Ride Checks

Check the following items each day before you ride. The time required is minimal, and habitual performance of these checks will help ensure a safe, reliable ride.

If any irregularities are found during these checks, refer to the appropriate section and take the action required to return the motorcycle to a safe operating condition.

WARNING

Failure to perform these checks before operation may result in serious damage or an accident. Always perform daily checks before operation.

DANGER

Exhaust gas contains carbon monoxide, a colorless, odorless poisonous gas. Inhaling carbon monoxide can cause serious brain injury or death. Do not run the engine in enclosed areas. Operate only in a well-ventilated area.

Engine

Transmission oil	<ul style="list-style-type: none"> ●No leakage ●Level correct
Coolant	<ul style="list-style-type: none"> ●No leakage ●Level correct (engine cold)
Radiator Cap	<ul style="list-style-type: none"> ●Properly installed
Spark Plug	<ul style="list-style-type: none"> ●Correctly torqued
Cylinder Head Nut	<ul style="list-style-type: none"> ●Correctly torqued
Cylinder Nut	<ul style="list-style-type: none"> ●Correctly torqued
Clutch	<ul style="list-style-type: none"> ●Functions properly
Carburetor	<ul style="list-style-type: none"> ●Properly tuned
Air Cleaner	<ul style="list-style-type: none"> ●Clean ●Properly installed

30 GENERAL INFORMATION

Muffler	●Apply oil to air cleaner element
Engine Sprocket	●No damage
	●No wear or damage
Frame	
Tires	●Overall condition good
	●No wear or damage
	●Pressure correct
Spokes	●No looseness
Drive Chain	●Overall condition good
	●Chain slack correct
	●Oil if necessary
Front and rear brakes	●Function properly
	●Lever and pedal play correct
	●No fluid leakage
Throttle	●Functions properly
	●Throttle grip returns smoothly
Steering	●Smooth but not loose from lock to lock
	●No binding due to control cables
Front Fork	●Functions properly
	●No oil leakage
Rear Shock Absorber	●Functions properly
	●No oil leakage
Fuel Tank	●Mounted securely
	●No fuel leakage
Rear Sprocket	●No wear or damage
Engine stop button	●Functions properly
Nuts, bolts, fasteners	●Properly tightened

After-Race Checks

After racing, first clean the motorcycle (see p. 103), then inspect the entire motorcycle with special attention to the air cleaner, carburetor, brakes, etc.

Carry out the general lubrication (see p. 105) and make necessary adjustments.

MAINTENANCE AND ADJUSTMENT

Periodic Maintenance Chart

The maintenance and adjustments outlined in this chapter are easily carried out and must be done in accordance with the Periodic Maintenance Chart to keep the motorcycle in good running condition.

JOB		FREQUENCY				As required	Page ref.	
		After each race (or 2.5 hours)	Every 3 races (or 7.5 hours)	Every 5 races (or 12.5 hours)	Every 10 races (or 25 hours)			
ENGINE	Clutch-adjust	●					52	
	Clutch and friction plates-check †		●	R			57	
	Throttle cable-adjust	●					49	
	Spark plug-clean/regap †	●	R				43	
	Air cleaner element-clean	●					47	
	Air cleaner element-replace	When damaged						46
	Carburetor-inspect and adjust	●					51	
	Transmission oil-change		●				37	
	Piston and piston ring-clean/check †		●	R			65	
	Cylinder head and cylinder-inspect		●				—	

JOB		FREQUENCY					
		After each race (or 2.5 hours)	Every 3 races (or 7.5 hours)	Every 5 races (or 12.5 hours)	Every 10 races (or 25 hours)	As required	See ref.
ENGINE	Silencer-clean/check †	•					72
	Silencer packing-change		•				72
	Small end bearing-check †		•		R		66
	Kick pedal and shift pedal-clean	•					–
	Exhaust pipe O-ring-replace		•				72
	Engine sprocket-check †	•					79
	Coolant-check †	•				R	38
	Radiator hoses/connections-check †	•					38
*Reed valve-check†	•					–	
CHASSIS	Brake adjustment-check †	•					81
	Brake pad wear-check †			•			84
	Brake fluid level-check †		•				83
	*Brake fluid-change	Every 2 years					–
	*Brake master cylinder cup and dust seal-replace	Every 2 years					–
	*Brake caliper piston seal and dust seal-replace	Every 2 years					–
	*Brake hose-replace	Every 4 years					–

34 MAINTENANCE AND ADJUSTMENT

JOB		FREQUENCY				As required	See ref.	
		After each race (or 2.5 hours)	Every 3 races (or 7.5 hours)	Every 5 races (or 12.5 hours)	Every 10 races (or 25 hours)			
CHASSIS	Spoke tightness and rim runout-check †	●					96, 97	
	Drive chain-adjust	●					75	
	Drive chain-lubricate	●					80	
	Drive chain wear-check †			●			77	
	Chain slipper and guide-replace	When damaged						78, 79
	Front fork-inspect/clean	●					86	
	*Front fork oil-change	1st time after 2 races, then every 5 races						–
	Nuts, bolts/fasteners-check †	●					99	
	Fuel system-clean	●					–	
	Fuel hose-replace	Every 5 years						–
	*Brake hoses, connections-check †	●					–	
	*Fuel hoses, connections-check †	●					–	
	Steering play-check †	●					85	
	*Steering stem bearing-grease			●			–	
	Rear sprocket-check †			●			79	

MAINTENANCE AND ADJUSTMENT 35

JOB		FREQUENCY						See ref.
		After each race (or 2.5 hours)	Every 3 races (or 7.5 hours)	Every 5 races (or 12.5 hours)	Every 10 races (or 25 hours)	As required		
CHASSIS	General lubrication-perform	●					105	
	*Wheel bearing-check †				●		-	
	*Swingarm and UNI-TRAK® linkage pivots-grease †			●			-	
	*Swingarm and UNI-TRAK® linkage pivots-check			●			-	
	*Rear shock oil-change	1st time after 2 races, then every 5 races					-	

†: Replace, add, adjust, clean or torque if necessary.

R: Replace

*: Should be serviced by referring to the Service Manual or an authorized Kawasaki dealer.

Transmission Oil

In order for the transmission and clutch to function properly, maintain the transmission oil at the proper level, and change the oil periodically.

WARNING

Vehicle operation with insufficient, deteriorated, or contaminated transmission oil will cause accelerated wear and may result in engine or transmission seizure, accident, and injury. Check the oil level before each use and change the oil and filter according to the periodic maintenance chart.

Oil Level Inspection

- Place the motorcycle perpendicular to the ground. If the motorcycle has just been used, wait several minutes for all the oil to settle. Check the transmission oil level through the oil level inspection window (oil level inspection window) on the lower right side of the engine. The oil should come up to the center of the oil level inspection window. If the oil

level is too high, remove the excess oil using a syringe or other suitable device. If the oil level is low, add the correct amount of oil through the oil filler opening. Use oil of the same type and brand as those of the one that is already in the engine.

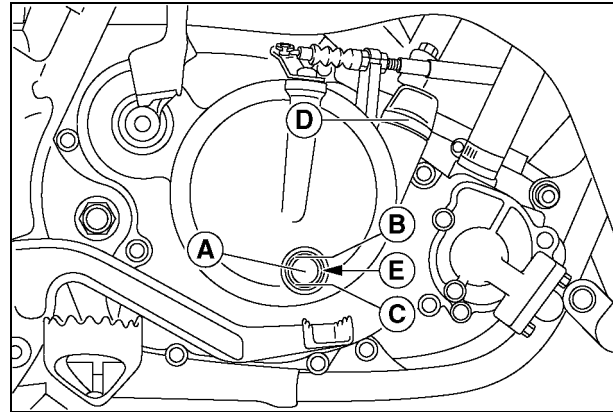

- A. Oil Level Inspection Window**
- B. Maximum**
- C. Minimum**
- D. Oil Filler Cap**
- E. Center of oil level inspection window**

Oil Change

The transmission oil should be changed periodically to ensure long engine life.

- Warm up the engine thoroughly so that the oil will pick up any sediment and drain easily.
- Stop the engine, and place a container beneath it.
- Remove the oil filler cap.
- Remove the oil drain plug and position the vehicle perpendicular to the ground to allow all the oil to drain.

⚠ WARNING
Transmission oil is a toxic substance. Dispose of used oil properly. Contact your local authorities for approved disposal methods or possible recycling.

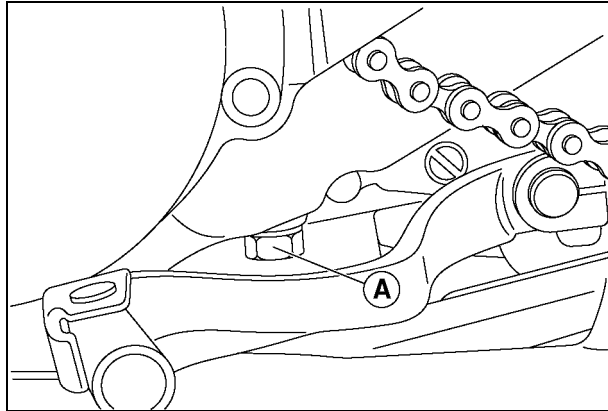

A. Oil Drain Plug

- Install the oil drain plug with its new gasket and torque it to 20 N·m (2.0 kgf·m, 14 ft·lb).
- Pour in the specified amount of fresh transmission oil.
- Install the oil filler cap.
- Check the oil level after kicking the engine over 3 or 4 times.

Recommended Transmission Oil

<p>Type: Kawasaki Performance 4-Stroke Motorcycle Oil* Kawasaki Performance 4-Stroke Semi-Synthetic Oil* Kawasaki Performance 4-Stroke Full Synthetic Oil* or other 4-stroke oils with API SG, SH, SJ, SL, SM and JASO MA, MA1, MA2 rating</p> <p>Viscosity: SAE10W-40</p>

*Kawasaki Performance Oils and Lubricants have been specifically engineered for your vehicle. Consistent use of these products meets or exceeds service requirements and can help to extend the life of your Kawasaki.

NOTE

- Do not add any chemical additive to the oil. Oils fulfilling the above requirements are fully formulated and provide adequate lubrication for both the engine and the clutch.

38 MAINTENANCE AND ADJUSTMENT

Transmission Oil Total Amount

0.5 L (0.53 US qt)

Although 10W-40 engine oil is the recommended oil for most conditions, the oil viscosity may need to be changed to accommodate atmospheric conditions in your riding area.

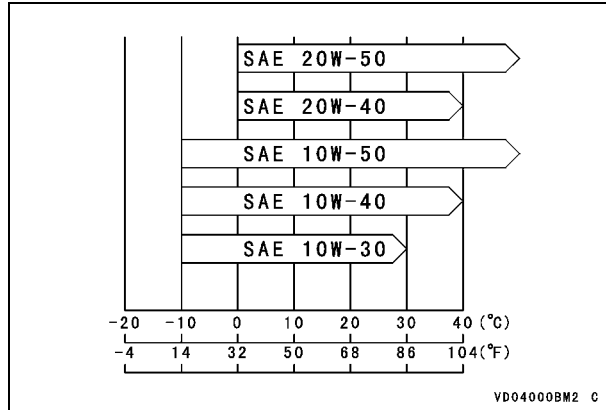

Cooling System

Radiator Hoses

Check the radiator hoses for cracks or deterioration, and the connections for looseness in accordance with the Periodic Maintenance Chart.

Radiator

Check the radiator fins for obstruction by insects or mud. Clean off any obstructions with a low-pressure stream of water.

NOTICE

Using high-pressure water, as from a car wash facility, could damage the radiator fins and impair the radiator's effectiveness.

Do not obstruct or deflect airflow by installing unauthorized accessories in front of the radiator.

Interference with the cooling airflow can lead to overheating and consequent engine damage.

Coolant

Coolant absorbs excessive heat from the engine and transfers it to the air through the radiator. If the coolant level becomes low, the engine overheats and may suffer severe damage. Check the coolant level each day before riding the motorcycle, and replenish coolant if the level is low.

⚠ WARNING

The cooling system can get extremely hot during normal operation and cause serious burns. Do not touch the radiator when it is hot, nor open the radiator cap. Hot coolant inside will cause severe burns.

NOTE

- *The coolant originally filled into the cooling system contains 50% of a permanent, ethylene-glycol-based antifreeze, has a freezing point of -35°C (-31°F) and a green appearance.*

Coolant Level Inspection

- Lean the motorcycle slightly to the right until the radiator cap is level to the ground, so that the radiator cap is located upper most in order to exhaust the air accumulated in the radiator.
- Remove the radiator cap in two steps.
- First, turn the cap counterclockwise to the first stop and wait there for a few seconds.
- Then, push and turn the cap further in the same direction and remove it.

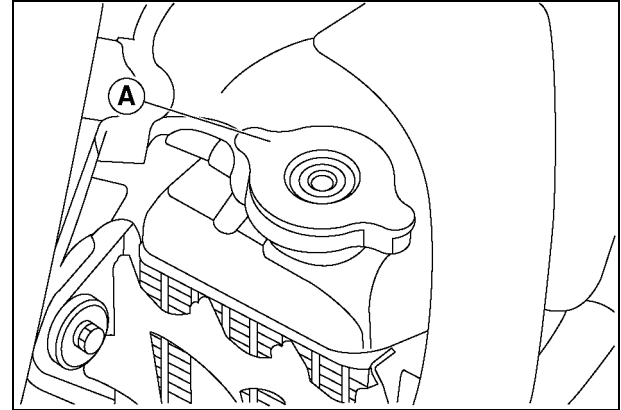

A. Radiator Cap

- Check the coolant level in the radiator. The coolant should come up to the bottom of the radiator filler neck.

NOTE

- *Check the coolant level when the engine is cold (room or ambient temperature).*

40 MAINTENANCE AND ADJUSTMENT

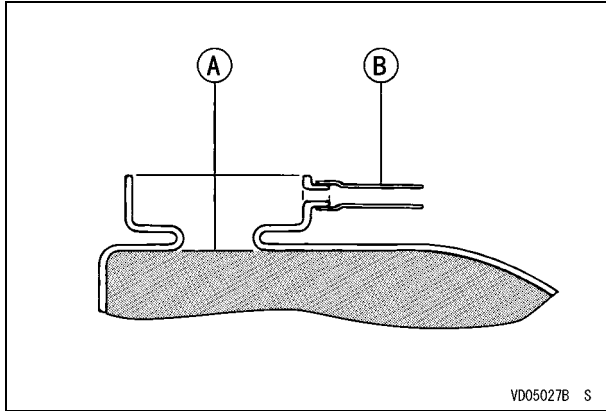

- A. Coolant Level**
- B. Radiator Breather Hose**

- If the coolant level is low, add coolant through the radiator filler opening to the bottom of the filler neck.

Water and Antifreeze Mixing Ratio

1 : 1 (water : antifreeze)

Recommended Antifreeze

Permanent type of antifreeze (ethylene glycol base plus corrosion and rust inhibitors for aluminum engines and radiators)

Coolant Total Amount

0.4 L (0.42 US qt)

- Install the radiator cap.

Coolant Change

The coolant should be changed periodically to ensure long engine life.

- Wait for the engine to cool completely.
- Lean the motorcycle slightly to the right until the radiator cap is level to the ground.
- Remove the radiator cap in two steps. (Refer to the “Coolant Level Inspection”)
- Place a container under the coolant drain plug at the water pump cover and remove the drain plug to drain the coolant from the radiator.

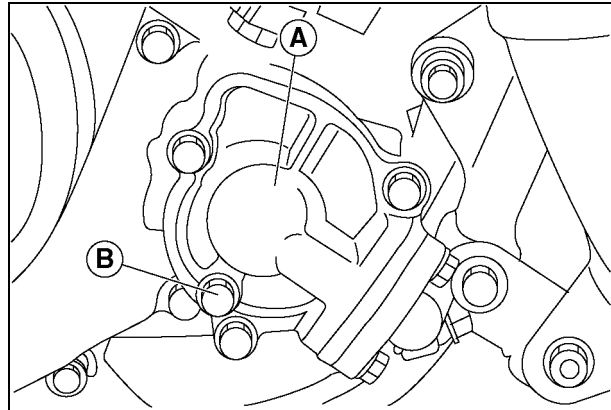

- A. Water Pump Cover**
- B. Coolant Drain Plug (Water Pump)**

NOTICE

Immediately wash away any coolant that spills on the frame, engine, or wheel.

 WARNING

Coolant on tires will make them slippery and can cause loss of traction resulting in an accident and injury. Thoroughly clean any coolant that might have splashed on the tires.

- Visually inspect the old coolant.
- If whitish cotton-like wafts are observed, aluminum parts in the cooling system are corroded and the system must be flushed.
- If the coolant is brown, iron or steel parts are rusting and the system must be flushed.
- Check the cooling system for damage, loose connections, and leaks.
- Install the coolant drain plug along the new gasket at the water pump cover. Apply the specified torques.

NOTICE

Always replace the gasket with a new one, if it is damaged.

Coolant Drain Plug (Water Pump) Tightening Torque

5.2 N·m (0.53 kgf·m, 46 in·lb)

- Fill the radiator up to the bottom of the radiator filler neck with coolant.
- Lean the motorcycle slightly to the right until the radiator filler neck is level to the ground so that the filler neck is located uppermost in order to exhaust the air accumulated in the radiator.

NOTICE

Use coolant containing corrosion inhibitors made specifically for aluminum engines and radiators in accordance with the instruction of the manufacture. Soft or distilled water must be used with the antifreeze (see below for antifreeze) in the cooling system. If hard water is used in the system, it causes scale accumulation in the water passages, and considerably reduces the efficiency of the cooling system.

NOTE

- *Pour in the coolant slowly so that it can expel the air from the radiator.*
- Bleed the air from the cooling system as follows.

42 MAINTENANCE AND ADJUSTMENT

- Loosen the air bleeder bolt on the cylinder head until the coolant begins to flow out the air bleeder bolt hole (that is, until all the remaining air has been forced out).

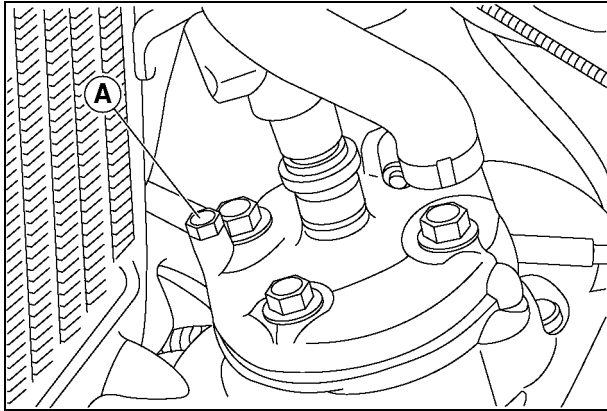

A. Air Bleeder Bolt

- Tighten the air bleeder bolt to the specified torque.

Air Bleeder Bolt Tightening Torque

9.4 N·m (0.96 kgf·m, 83 in·lb)

- Tap the cooling hoses to force out any air bubbles caught inside.

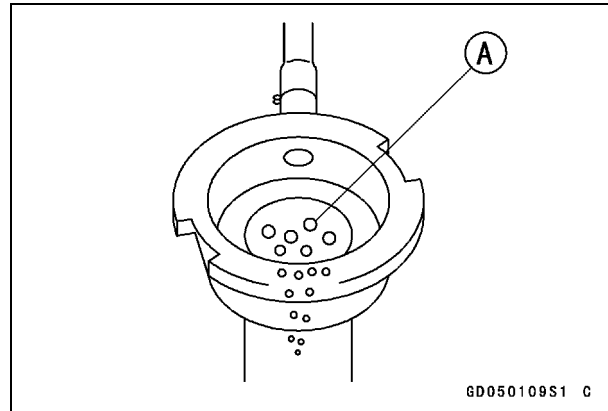

A. Air Bubbles

- Check the coolant level.
- If the coolant level is low, add coolant up to the bottom of the radiator filler neck.
- Install the radiator cap.
- Check the cooling system for leaks.
- Start the engine and warm up thoroughly, then stop it.
- Check the coolant level after the engine has cooled down. If the coolant level is low, add coolant up to the bottom of the radiator filler neck.

Spark Plug

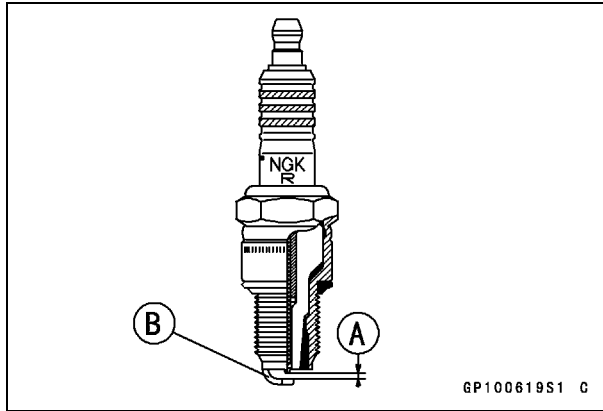

- A. Spark Plug Gap**
- B. Outer Electrode**

The spark plug should be taken out periodically for inspection and regapping. Measure the gap with a wire-type thickness gauge. If incorrect, adjust the gap to the specified value by bending the outer electrode.

Spark Plug Gap

NGK BR9EG, BR10EG, BR10EIX	0.5 ~ 0.6 mm (0.020 ~ 0.024 in.)
-------------------------------	-------------------------------------

If the plug is oily or has carbon built up on it, clean it. The plug may also be cleaned using a high flash-point solvent and a nonmetal brush (nylon etc.). If the spark plug electrodes are corroded, or damaged, or if the insulator is cracked, replace the plug. The standard spark plug is shown in the table below.

Standard Spark Plug

NGK BR10EG

To find out whether the plug's heat range is correct, remove the plug and examine the ceramic insulator around the center electrode. If the ceramic is light brown, the spark plug correctly matches the engine temperature.

If the ceramic is black, the plug should be replaced with a hotter plug.

Optional Spark Plug

Hotter	NGK BR9EG
--------	-----------

44 MAINTENANCE AND ADJUSTMENT

Spark Plug Removal and Installation

- Pull the spark plug cap off the plug before removing the spark plug.
- Apply a suitable wrench to the spark plug.
- Loosen and remove the spark plug.
- When reinstalling the spark plug, torque it to the specification.

Spark Plug Tightening Torque

25.5 N·m (2.55 kgf·m, 18.4 lb)

- Fit the plug cap securely onto the spark plug, and pull the cap lightly to make sure that it is properly installed.

NOTE

- If the engine performance drops, try replacing the spark plug to regain performance.

Ignition Timing

Since this motorcycle is equipped with a capacitor discharge ignition (CDI) system, the ignition timing should never require adjustment unless the stator was incorrectly installed during engine reassembly. If there is any doubt as to the timing, inspect and, if necessary, adjust it as follows.

- Remove the magneto cover and the gasket. If the gasket is damaged, it should be replaced.

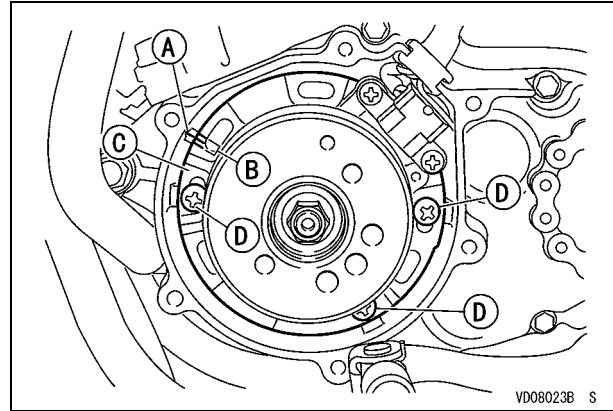

- A. Timing Mark (Crankcase)
- B. Timing Marks (Stator)
- C. Stator
- D. Stator Screw

- If the marks are not aligned, loosen the stator screws and turn the stator to align the marks.
- Tighten the screws securely.

- Install the magneto cover and the gasket.
- Remove the magneto cover and gasket.
- Loosen the stator screws.
- Adjust the timing by shifting the stator position within the range offered by the three timing marks on the stator.

The ignition timing can be adjusted to suit the rider's preference and ability.

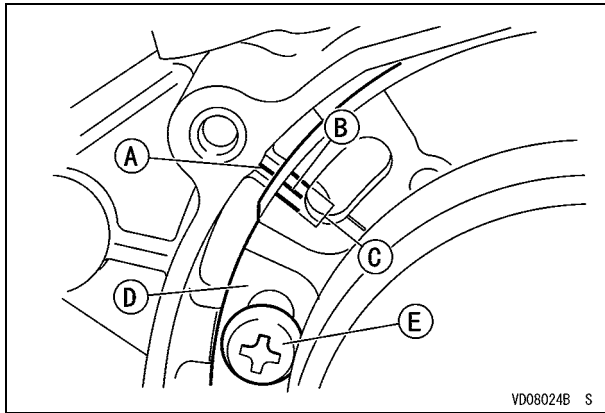

- A. Timing Mark (Crankcase)**
- B. Standard Adjustment**
- C. Adjustable Range**
- D. Stator**
- E. Stator Screw**

NOTE

○ *For best engine performance, it is very important to adjust the ignition timing within the adjustable range.*

- Tighten the stator screws securely.
- Install the magneto cover, and the gasket.
- Test ride the motorcycle and readjust the ignition timing if necessary.

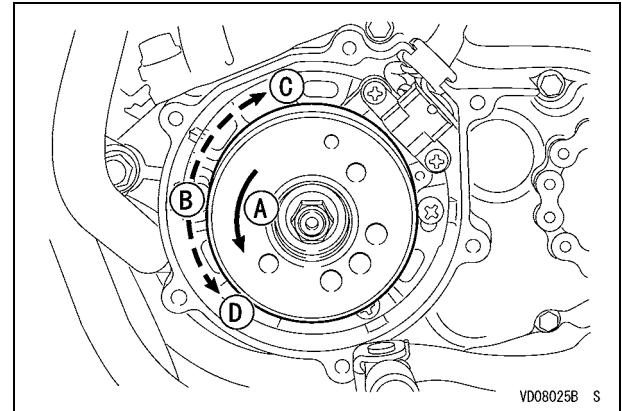

- A. Crankshaft Rotation**
- B. Stator Movement**
- C. Advance**
- D. Retard**

46 MAINTENANCE AND ADJUSTMENT

Air Cleaner

A clogged air cleaner restricts the air intake, increases fuel consumption, reduces engine power, and can cause spark plug fouling. Inspect the air intake system, which includes the air filter and air duct to the carburetor, and the duct clamps and carburetor, before each race or practice session.

⚠ WARNING

If dirt or dust is allowed to pass through into the carburetor, the throttle may become stuck, possibly causing accident. Be sure to keep the dust from entering during cleaning.

NOTICE

A clogged air cleaner will affect fuel mixture to the engine and reduce engine power and cause spark plug fouling.

NOTE

- In dusty areas, the element should be cleaned more frequently than recommended interval.
- After riding through rain or on muddy roads, the element should be cleaned immediately.

Element Removal and Inspection

- Remove the seat.
- Remove the wing bolt, and take out the air cleaner element.

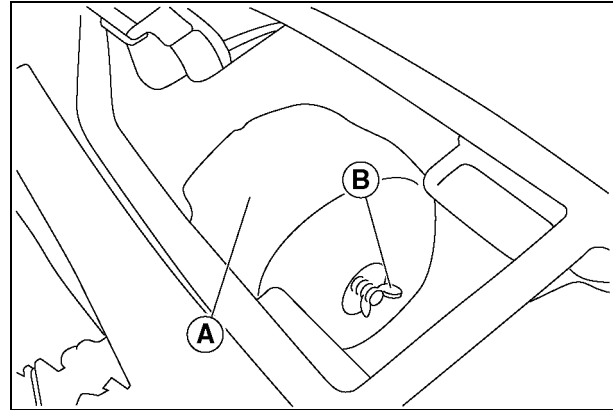

A. Air Cleaner Element
B. Wing Bolt

- Check inside of the intake tract and carburetor for dirt. If dirty, clean the intake tract and carburetor thoroughly.
- Stuff a clean, lint-free towel into the carburetor to keep dirt from entering the carburetor.
- Wipe out the inside of the air cleaner housing with a clean, damp towel.
- Take the element off its frame.

NOTICE

Do not twist or wring the element, as it gets easily torn or damaged.

- Inspect the element. If it is dirty, clean it. Also check if the element is in good condition (no tears, hardening or shrinkage). If damaged, replace the element or it will allow dirt into the carburetor.

⚠ WARNING

A clogged air cleaner may allow dirt and dust to enter the carburetor and the throttle may stick resulting in a hazardous operating condition. Clean the air cleaner according to the periodic maintenance chart; more often if the motorcycle is used in extremely dusty conditions.

NOTICE

A clogged air cleaner may allow dirt and dust to enter the engine, causing it to wear excessively or to become damaged.

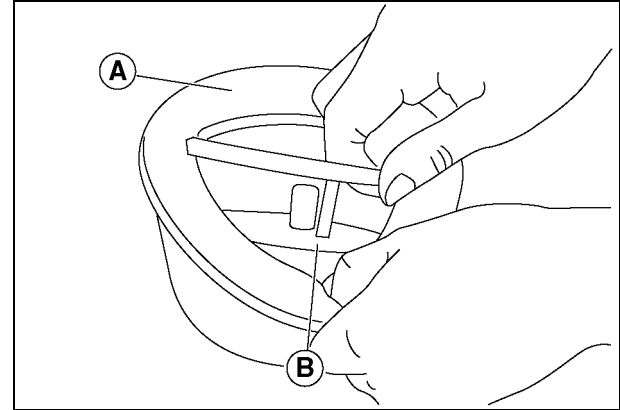

**A. Air Cleaner Element
B. Element Frame**

Element Cleaning and Installation

- Clean the element in a bath of a high flash-point solvent or hot soapy water. Rinse the element with clear water to remove all traces of the cleaning solution.
- Squeeze the element dry in a clean towel.

NOTICE

Do not twist, wring or blow the element dry to avoid damaging it.

48 MAINTENANCE AND ADJUSTMENT

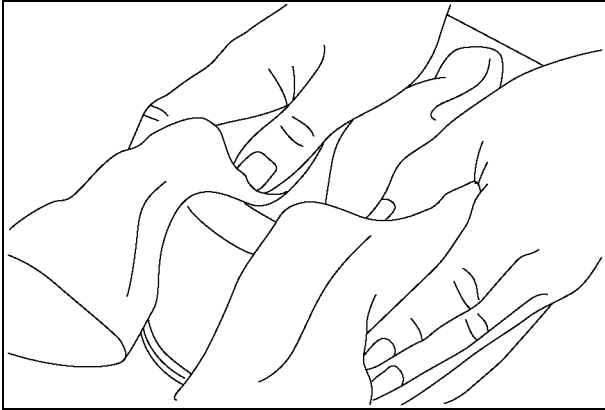
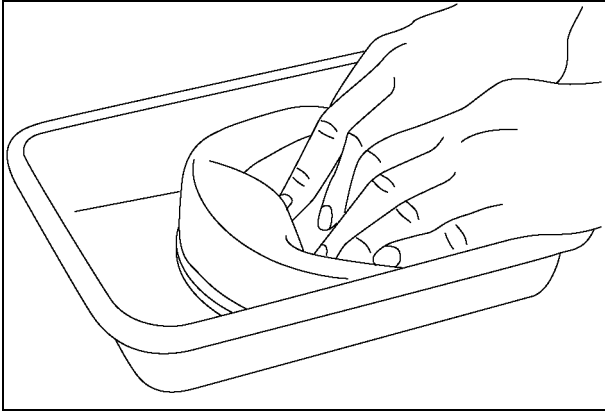

⚠ WARNING

Gasoline and low flash-point solvents can be flammable and/or explosive and cause severe burns. Clean the element in a well-ventilated area, and take care that there is no spark or flame anywhere near the working areas. Do not use gasoline or low flash-point solvents to clean the element.

- After cleaning, let the filter dry completely. Saturate the element with a high-quality foam air filter oil and make sure that the oil is evenly applied throughout the element. Squeeze out the excess oil, but do not wring the element as this could cause tearing. In this case, too much oil is better than too little. Finally pat the inside of the element with a paper towel to remove any excess oil.
- Before installation, check the element for damage such as tears, hardening, or shrinkage. If damaged, replace the element.
- Apply grease to all mating surfaces and to the screw hole in the air cleaner housing and intake tract.
- Remove the towel from the carburetor.
- Install the element onto its frame, and coat the element lip and lip seat with a thick layer of all-purpose grease to assure a complete seal.

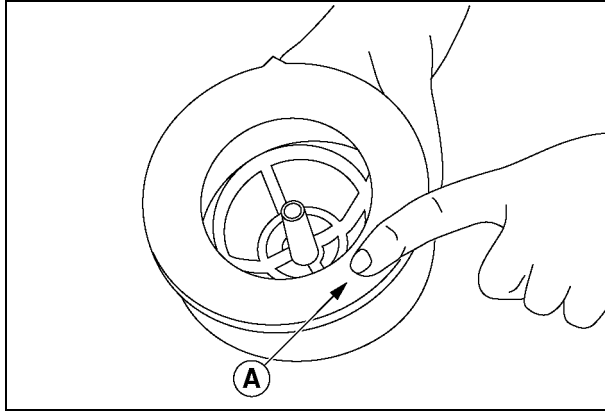

A. Apply grease.

- Install the air cleaner element, making sure that it is properly seated and sealed.
- Install the parts removed.

Throttle Cable

Throttle Cable Adjustment

Inspect the throttle grip for smooth operation in all steering positions. Check and adjust the throttle cable in accordance with the Periodic Maintenance Chart.

- Check that the throttle grip has 2 ~ 3 mm (0.08 ~ 0.12 in.) of play and turns smoothly.

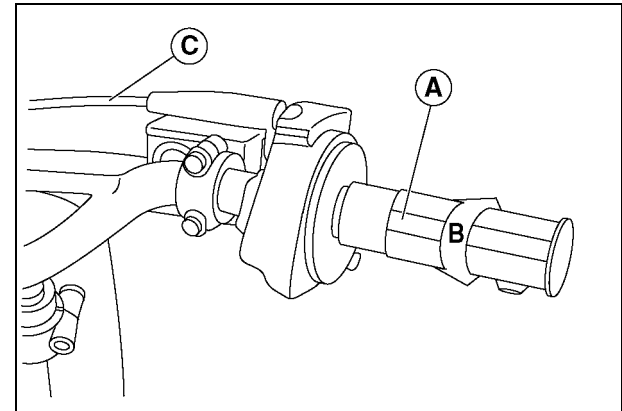

- A. Throttle Grip**
- B. 2 ~ 3 mm (0.08 ~ 0.12 in.)**
- C. Throttle Cable**

50 MAINTENANCE AND ADJUSTMENT

- If the play is incorrect, pull the rubber boot off the upper end of the throttle cable, loosen the locknut on the upper end of the throttle cable and turn the adjuster to obtain the specified play. Then, tighten the locknut.
- Reinstall the rubber boot.

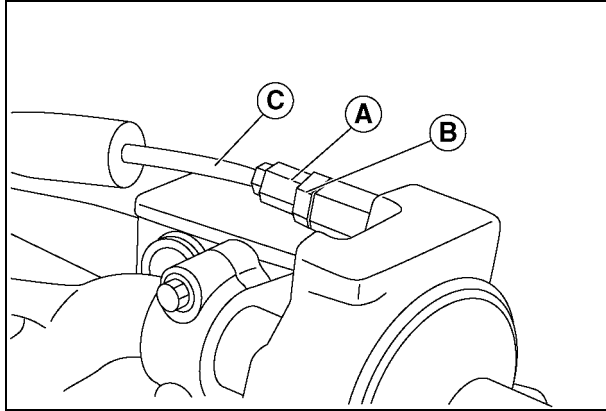

A. Adjuster
B. Locknut
C. Throttle Cable

- If the free play cannot be set with the adjuster on the upper end of the throttle cable, pull the rubber boot off top of the carburetor and make the necessary free play adjustment with the adjuster on the lower end of the cable. Then, tighten the locknut and reinstall the rubber boot.

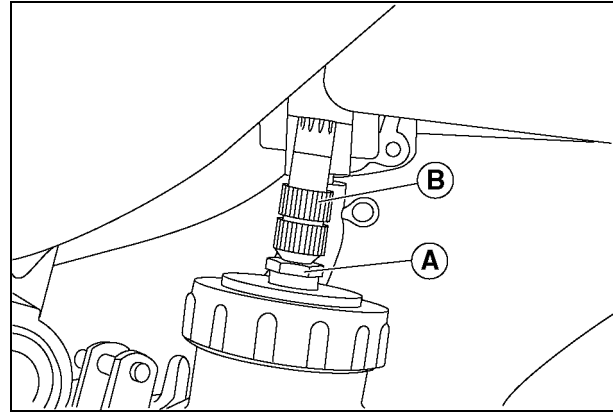

A. Locknut
B. Adjuster

- With the engine idling, turn the handlebar both ways and check if handlebar movement changes the idling speed. If so, the throttle cable may be improperly adjusted or incorrectly routed, or damaged. Be sure to correct any of these conditions before riding.

WARNING

Operation with an improperly adjusted, incorrectly routed, or damaged cables could result in an unsafe riding condition. Be sure the control cables are adjusted and routed correctly, and are free from damage.

Carburetor

Idling Adjustment

Idling adjustment is carried out using the air screw and idling adjusting screw.

- First turn the air screw in until it is lightly seated, then back it out 1 1/2 turns.
- Start the engine and warm it up thoroughly.
- Turn the idling adjusting screw to obtain the desired idling speed. If you do not wish the engine to idle, turn out the screw until the engine stops.

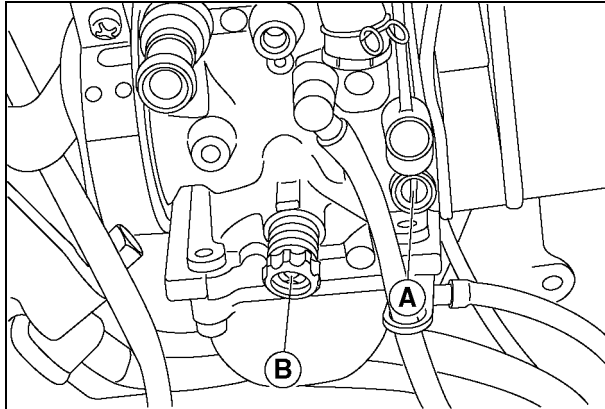

A. Air Screw
B. Idling Adjusting Screw

- Open and close the throttle a few times to make sure the idling speed does not change, and readjust if necessary.
- With the engine idling, turn the handlebar both ways and check if handlebar movement changes the idling speed. If so, the throttle cable may be improperly adjusted, incorrectly routed, or damaged. Be sure to correct any of these conditions before riding.

⚠ WARNING

Operation with damaged cables could result in an unsafe riding condition. Replace damaged control cables before operation.

Clutch

Clutch Lever Adjustment

Proper clutch lever play is 8 ~ 13 mm (0.3 ~ 0.5 in.). Lever play increases with cable stretch and friction plate wear, requiring periodic adjustment.

When the clutch lever play is out of specification, first try adjusting it at the clutch lever as follows.

- Slide the clutch lever dust cover back.
- Loosen the locknut, turn the adjuster to obtain the proper amount of clutch lever play, then tighten the locknut.

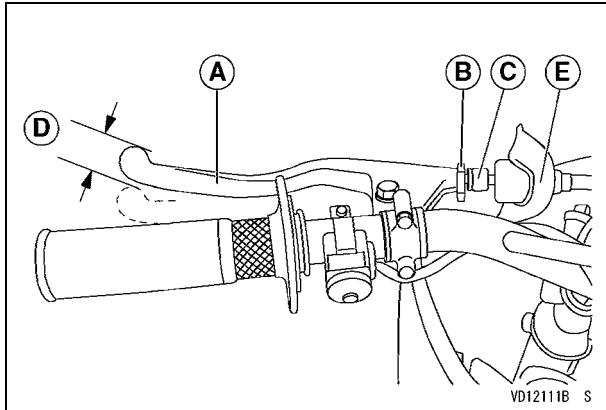

- A. Clutch Lever
- B. Locknut
- C. Adjuster
- D. 8 ~ 13 mm (0.3 ~ 0.5 in.)
- E. Dust Cover

- Slide back the clutch lever dust cover.
- Loosen the locknut at the clutch lever.
- Turn the adjuster in all the way, then tighten the locknut.
- Loosen the nuts and turn them so that the clutch lever play is 8 ~ 13 mm (0.3 ~ 0.5 in.).

If the clutch lever play cannot be adjusted at the clutch lever, make the adjustment further down the cable as follows.

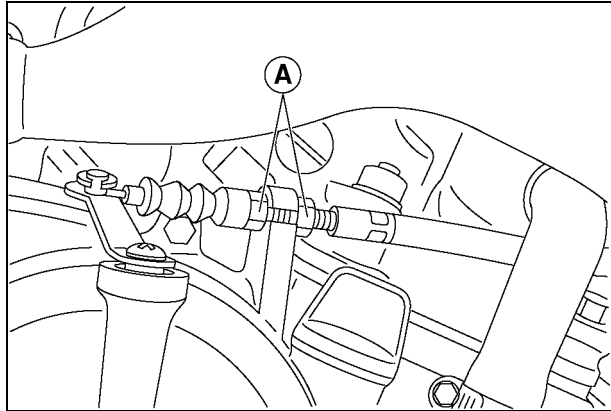

A. Nuts

- Tighten the nuts.
- Start the engine, check that the clutch does not slip and it releases properly.
- Slide the dust cover back into place.

Friction Plate Removal

- Drain the transmission oil and coolant (see the Transmission Oil section and Cooling System section).
- Give plenty of play to the clutch cable by turning the adjuster.
- Line up the slots in the clutch lever, locknut, and adjuster, and then free the cable from the clutch lever.

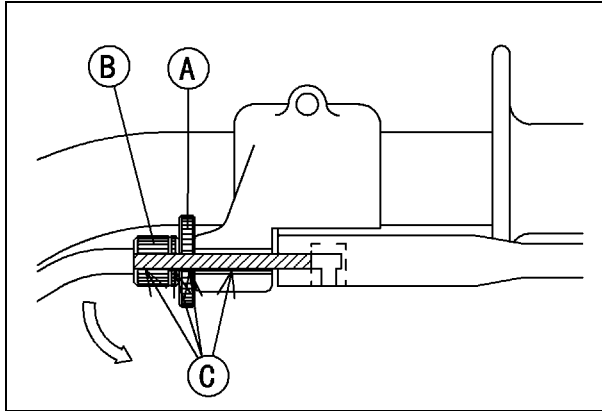

- A. Locknut
- B. Adjuster
- C. Slots

- Free the clutch inner cable tip from the clutch release lever.

NOTICE

Do not remove the clutch release shaft unless it is absolutely necessary. If the clutch release shaft is removed, the oil seal must be replaced with a new one.

- Remove the kick pedal.

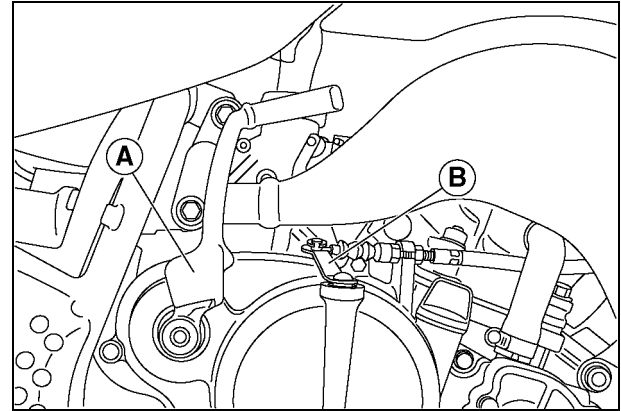

- A. Kick Pedal
- B. Clutch Release Lever

54 MAINTENANCE AND ADJUSTMENT

- Remove the cotter pin, pivot pin and washer from the rear brake pedal.

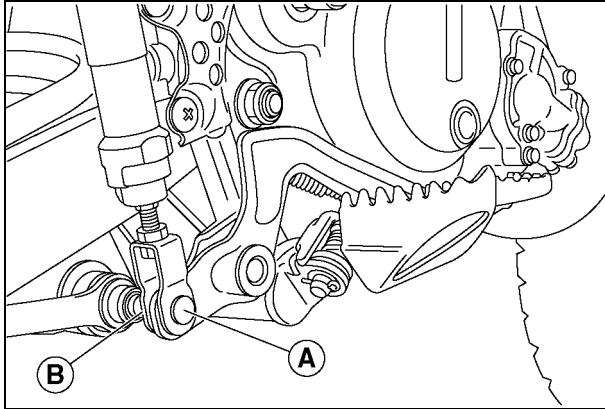

A. Rear Brake Pedal Pivot Pin
B. Cotter Pin

- Remove the brake pedal mounting bolt and take off the brake pedal and return spring.

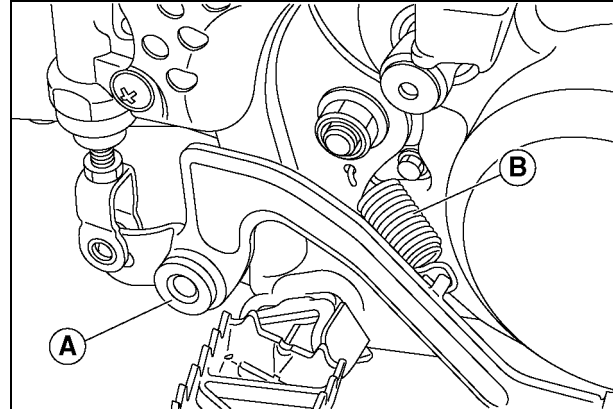

A. Brake Pedal Mounting Bolt
B. Brake Pedal Return Spring

- Loosen the water pump hose clamp, and disconnect the lower end of the water pump hose.
- Unscrew the water pump cover bolts, and remove the water pump cover and gasket.

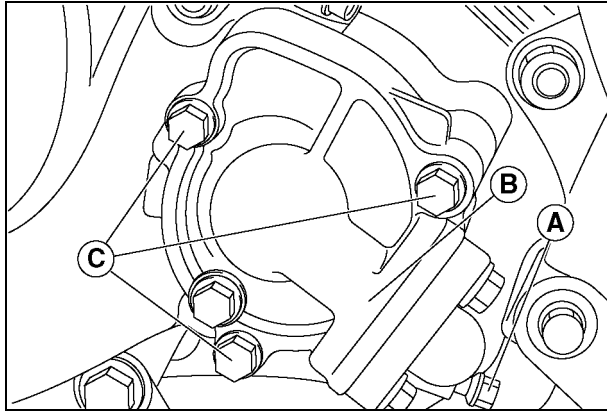

- A. Water Pump Hose Clamp
- B. Water Pump Cover
- C. Water Pump Cover Bolt

- Remove the impeller bolt, and take out the impeller and washer.

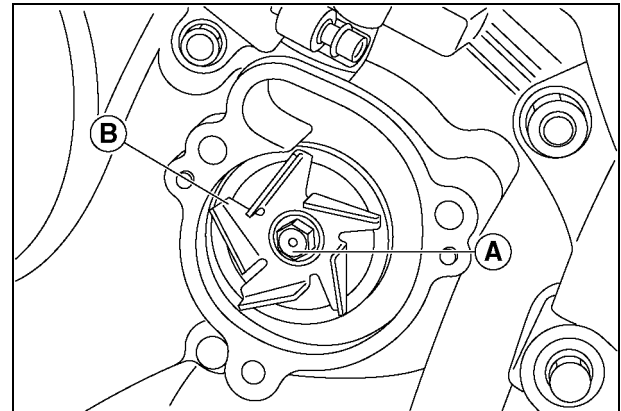

- A. Impeller Bolt
- B. Impeller

56 MAINTENANCE AND ADJUSTMENT

- Remove the right engine cover mounting bolt after pulling off the lower end of the coolant hose.
- Turn the clutch release lever toward the rear, and remove the right engine cover and gasket.

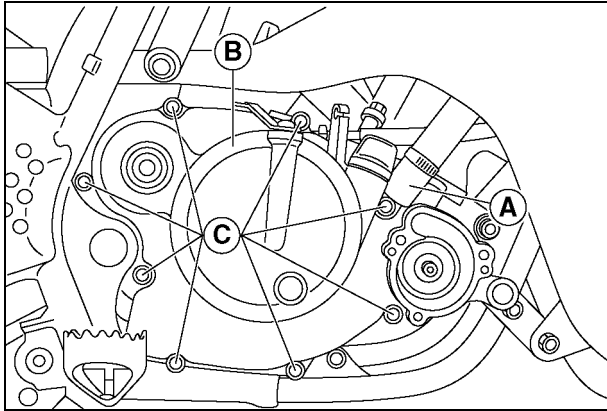

- A. Coolant Hose
- B. Right Engine Cover
- C. Bolt

- Remove the clutch pusher, and clutch spring plate pusher.

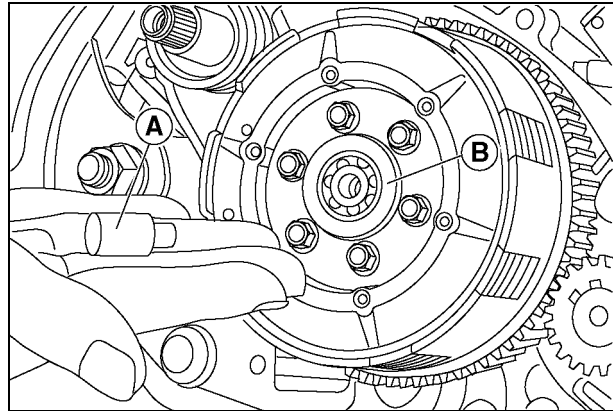

- A. Clutch Pusher
- B. Clutch Spring Plate Pusher

- Remove the magneto cover.
- Hold the magneto flywheel steady with the flywheel holder to prevent clutch from rotating.

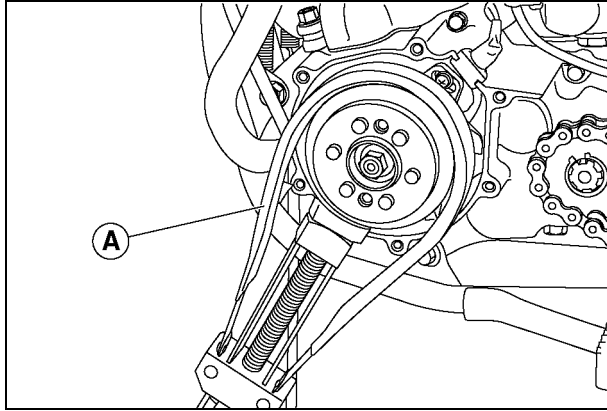

A. Flywheel Holder

- Remove the clutch hub bolt, clutch spring bolts, clutch spring holder, springs and clutch hub.

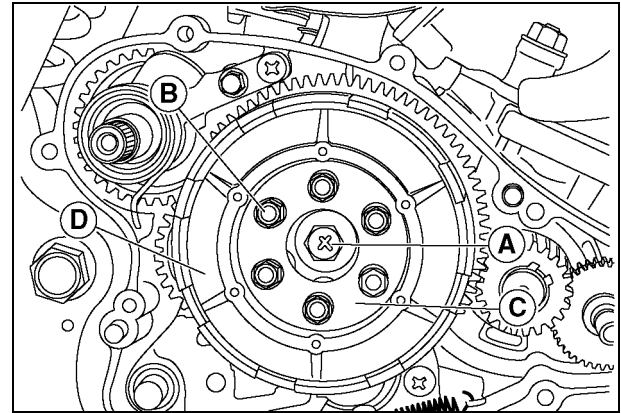

- A. Clutch Hub Bolt**
- B. Clutch Spring Bolts (6)**
- C. Clutch Spring Holder**
- D. Clutch Hub**

- Remove the friction plates and steel plates.

Friction and Steel Plate Wear/Damage Inspection

- Visually inspect the friction and steel plates to see if they show any signs of seizure, or uneven wear.
- If any plates show signs of damage, replace all friction plates and steel plates as a set.
- Measure the thickness of the friction and steel plates with vernier calipers.
- If they have worn past the service limit, replace them with new ones.

58 MAINTENANCE AND ADJUSTMENT

Friction Plate Thickness Measurement

Standard	3.1 ~ 3.3 mm (0.122 ~ 0.130 in.)
Service Limit	2.9 mm (0.114 in.)

Steel Plate Thickness Measurement

Standard	1.47 ~ 1.73 mm (0.0579 ~ 0.0681 in.)
Service Limit	1.37 mm (0.0539 in.)

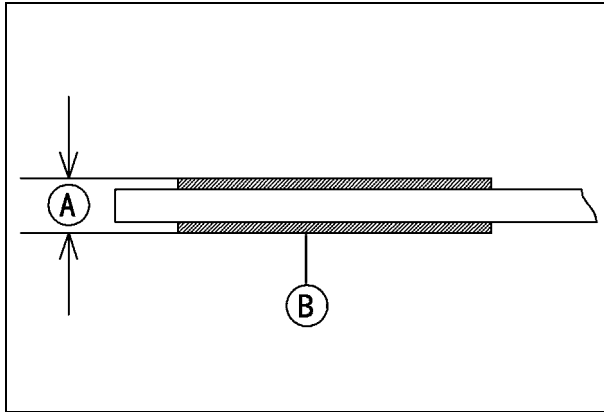

A. Thickness
B. Friction Plate

Friction and Steel Plate Warp Inspection

- Place each friction plate and steel plate on a surface plate, and measure the amount of friction plate and steel plate warp with a thickness gauge

(i.e., the gap between the surface plate and each friction plate or steel plate).

- If any plate is warped over the service limit, replace it with a new one.

Friction and Steel Plate Warp

Friction Plate	Standard	Maximum 0.2 mm (0.008 in.)
	Service Limit	0.3 mm (0.012 in.)
Steel Plate	Standard	Maximum 0.15 mm (0.006 in.)
	Service Limit	0.3 mm (0.012 in.)

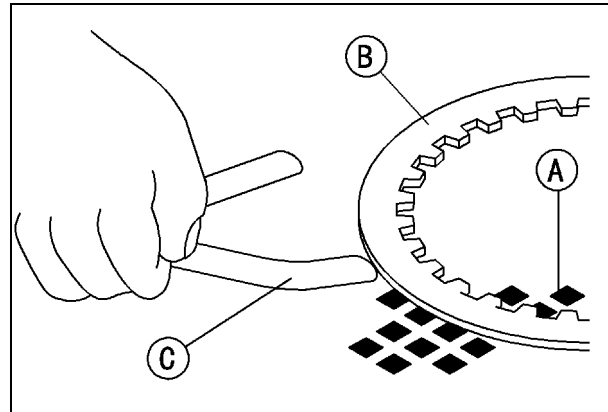

A. Surface Plate
B. Friction or Steel Plate
C. Thickness Gauge

Friction and Steel Plate Installation

- Install all parts in the reverse order of removal.
- Install the friction plates and steel plates, alternating between the two; be sure to start and finish with a friction plate.

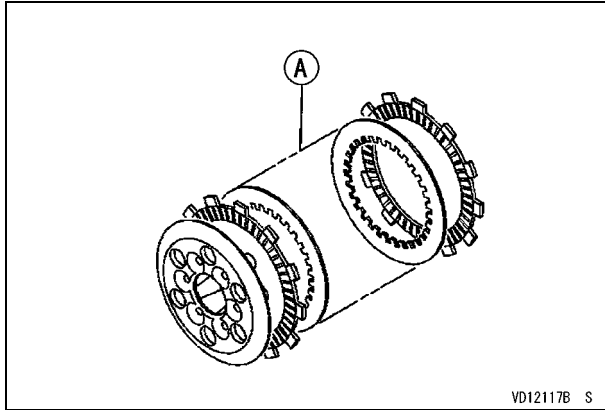

A. Friction and Steel Plates

NOTICE

If dry steel plates and friction plates are installed, apply transmission oil to the surfaces of each plate to avoid clutch plate seizure.

- Install the clutch hub, springs and clutch spring holder.
- Tighten the clutch hub bolt and clutch spring bolts.

Clutch Hub Nut Tightening Torque

64 N·m (6.5 kgf·m, 47 ft·lb)

Clutch Spring Bolt Tightening Torque

9.3 N·m (0.95 kgf·m, 82 in·lb)

- Apply molybdenum disulfide grease to the clutch spring plate pusher.
- Install the clutch pusher and clutch spring plate pusher.
- Install the magneto cover and gasket.
- Apply molybdenum disulfide grease to the water pump shaft to prevent water pump seal damage.

NOTICE

If the right engine cover is installed without greasing the water pump shaft, the pump seal could be damaged.

60 MAINTENANCE AND ADJUSTMENT

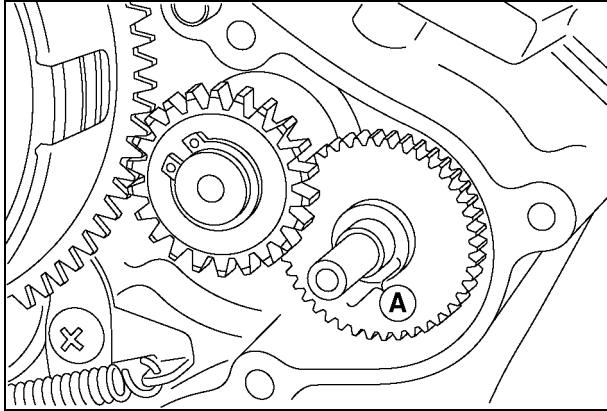

A. Apply grease.

- Turn the clutch release lever toward the rear.
- Place a new right engine cover gasket in position with a thin layer of grease.
- Apply a high-temperature grease to the kick shaft oil seal lips and kick shaft spline.
- Install the right engine cover to the crankcase, making sure that the two dowel pins are installed between the making surfaces.
- Route the breather hose through the clamp and position it as shown with the right engine cover mounting bolt.

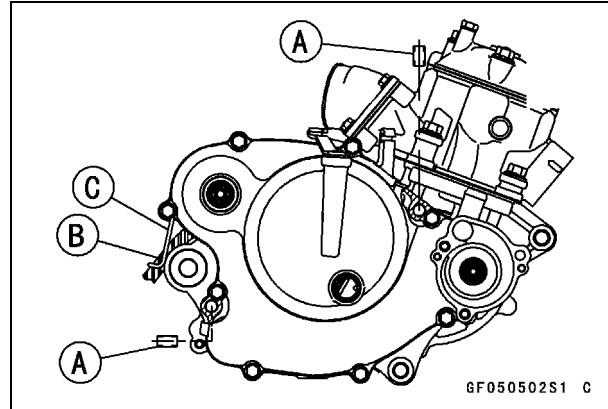

- A. Dowel Pins
- B. Breather Hose
- C. Clamp

- Tighten the right engine cover mounting bolts.

Right Engine Cover Mounting Bolt Tightening Torque

9.4 N·m (0.96 kgf·m, 83 in·lb)

- Connect the lower end of the coolant hose, and tighten the clamp screw securely.
- Install the impeller and washer to the right engine cover, and tighten the impeller bolt.

Impeller Bolt Tightening Torque

8.3 N·m (0.85 kgf·m, 74 in·lb)

- Place a new water pump cover gasket, and install the water pump cover, and tighten the water pump cover bolt.

Water Pump Cover Bolt Tightening Torque

9.4 N·m (0.96 kgf·m, 83 in·lb)

- Connect the lower end of the water pump hose, and tighten the clamp screw securely.
- Check the brake pedal O-ring for damage, and if necessary, replace them with a new one.
- Apply a high-temperature grease to the shaft portion of the rear brake pedal, install the rear brake pedal and attach the return spring onto the frame.

Brake Pedal Mounting Bolt Tightening Torque

25 N·m (2.5 kgf·m, 18 ft·lb)

- Install a new cotter pin, pivot pin and washer to the rear brake pedal, and spread the ends of the cotter pin.
- Install the kick pedal, and connect the clutch cable.

Kick Pedal Bolt Tightening Torque

9.4 N·m (0.96 kgf·m, 83 in·lb)

- Test the braking power and check that there is no brake drag.

⚠ WARNING

Air in the brake lines diminish braking performance and can cause an accident resulting in injury or death. If the brake lever or pedal feels mushy when it is applied, there might be air in the brake lines or the brake may be defective. Have the brake checked immediately by an authorized Kawasaki dealer.

- Adjust the clutch cable.
- Check the transmission oil level and coolant level.
- Install the parts removed.

62 MAINTENANCE AND ADJUSTMENT

Piston

Piston Removal

- Turn the fuel tap lever to the OFF position.
- Drain the coolant (See the Cooling System section).
- Remove the seat and the left and right side covers.
- Remove the left and right radiator covers, and disconnect the clutch cable (see the Clutch section).
- Disconnect the fuel hose from the fuel tap.
- Remove the fuel tank mounting bolt and band.
- Remove the fuel tank.

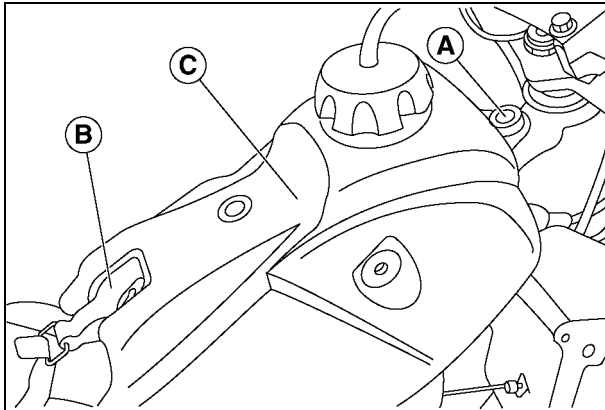

- A. Fuel Tank Mounting Bolt**
- B. Fuel Tank Mounting Band**
- C. Fuel Tank**

- Remove the muffler (See the Exhaust System section).
- Remove the springs holding the exhaust pipe.

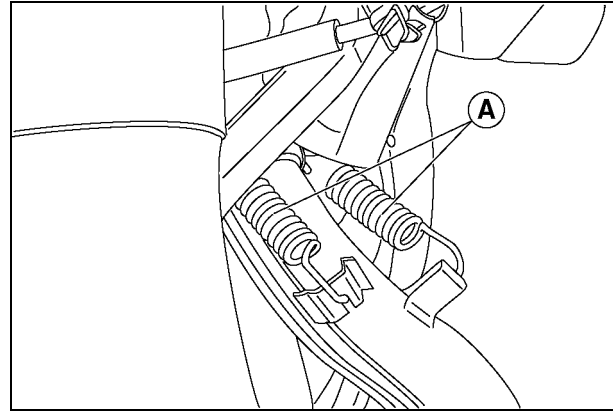

- A. Springs**

- Remove the exhaust pipe damper mounting bolts, and pull the exhaust pipe off toward the front.

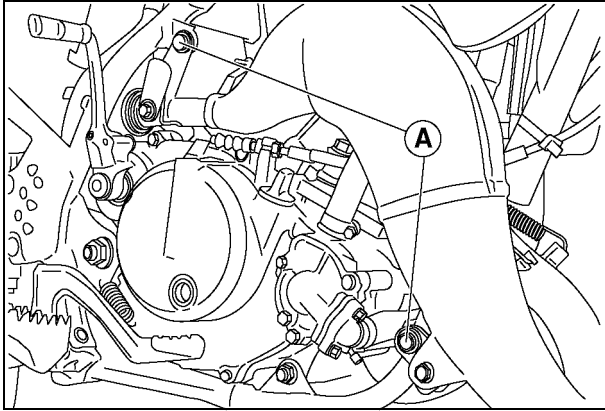

A. Exhaust Pipe Damper Mounting Bolts

- Remove the exhaust pipe gasket.
- Loosen the clamp screws and pull the carburetor out of the cylinder intake joint and air cleaner joint.

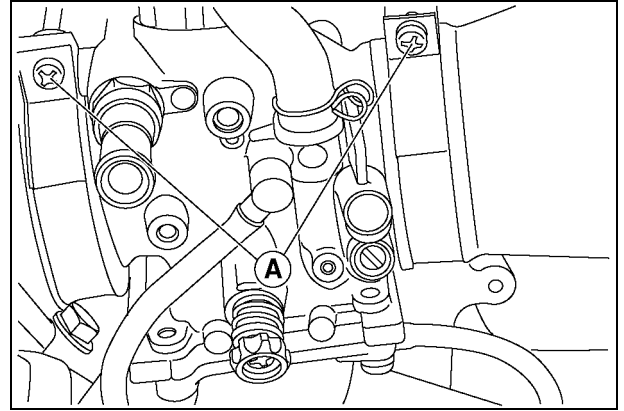

A. Clamp Screws

64 MAINTENANCE AND ADJUSTMENT

- Disconnect the coolant hose at the cylinder head.
- Remove the spark plug.
- Remove the cylinder head nuts, and take off the cylinder head and gasket.

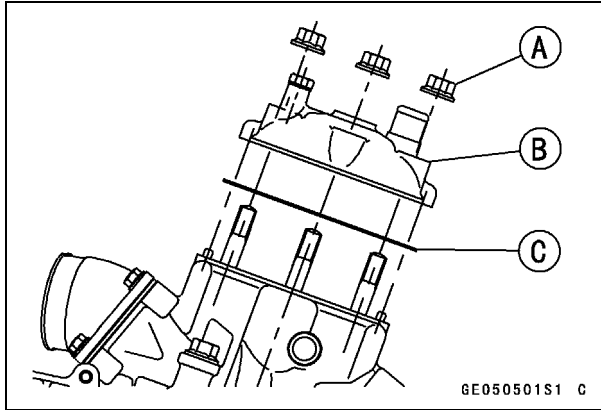

- A. Cylinder Head Nuts**
- B. Cylinder Head**
- C. Cylinder Head Gasket**

- Remove the cylinder nuts.
- Lift off the cylinder, and remove the cylinder base gasket. If necessary, tap lightly around the base of the cylinder with a plastic mallet, taking care not to damage the cylinder.

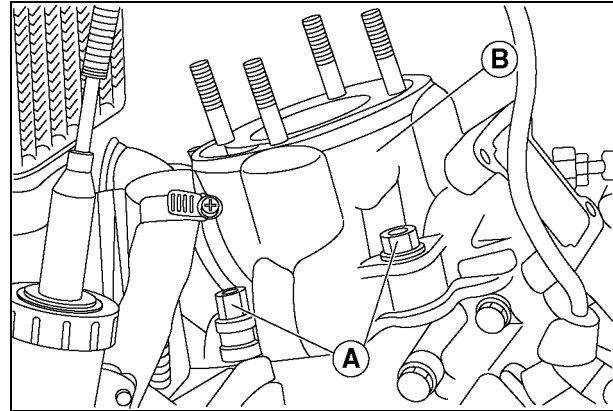

- A. Cylinder Nuts**
- B. Cylinder**

- Stuff a clean cloth into the crankcase opening around the connecting rod so that no parts will fall into the crankcase.
- Remove one of the piston pin snap rings with needle nose pliers.
- Push the piston pin out from the side that the snap ring was removed and remove the piston. Use a piston pin puller assembly (special tool), if the pin is tight.

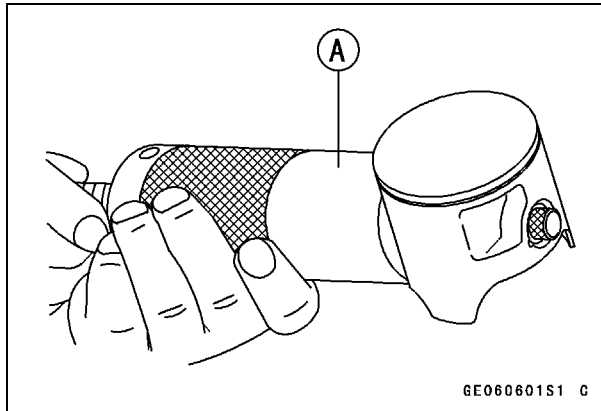

A. Piston Pin Puller Assembly: 57001-910

Piston Ring Removal

- Carefully spread the ring gap with your thumbs and then push up on the opposite side of the ring to remove it.

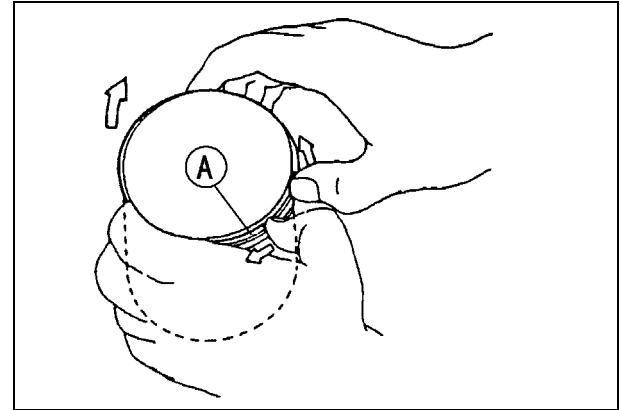

A. Piston Ring

Piston Ring, Piston Ring Groove Inspection

- Visually inspect the piston rings and the piston ring grooves.
- If the rings are worn unevenly or damaged, they must be replaced.
- If the piston ring grooves are worn unevenly or damaged, the piston must be replaced and fitted with new rings.
- Check for uneven the piston ring groove wear by inspecting the ring seating.

66 MAINTENANCE AND ADJUSTMENT

- The piston rings should fit perfectly parallel to the groove surfaces. If not, the piston must be replaced.
- With the piston ring in its groove, make several measurements with a thickness gauge to determine piston ring/groove clearance.

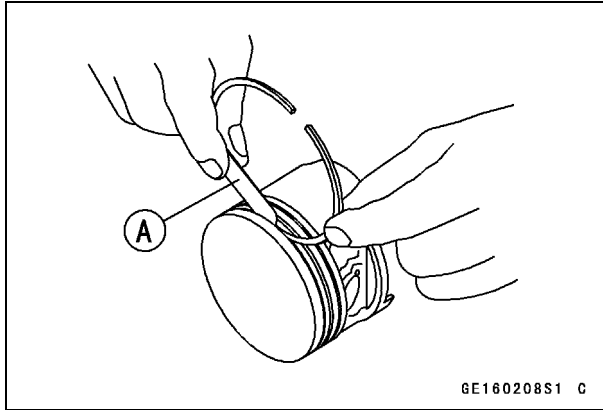

A. Thickness Gauge

Piston Ring/Groove Clearance (Top and Second)

Standard	0.02 ~ 0.06 mm (0.0008 ~ 0.0024 in.)
Service Limit	0.16 mm (0.0063 in.)

- If the piston ring/groove clearance exceeds the service limit, measure the thickness of the piston ring.

- If the piston ring has worn down to less than the service limit, replace the ring; if the piston ring groove width exceeds the service limit, replace the piston.

Piston Ring Thickness (Top and Second)

Standard	0.97 ~ 0.99 mm (0.0382 ~ 0.0390 in.)
Service Limit	0.90 mm (0.0354 in.)

Piston Ring Groove Width (Top and Second)

Standard	1.01 ~ 1.03 mm (0.0398 ~ 0.0406 in.)
Service Limit	1.11 mm (0.0437 in.)

Piston, Piston Pin, Connecting Rod Wear Inspection

- If the piston pin hole groove shows excessive wear, replace the piston.
- Measure the diameter of the piston pin with a micrometer.
- If the piston pin diameter is less than the service limit at any point, replace the piston pin.

Piston Pin Diameter

Standard	11.995 ~ 12.000 mm (0.4722 ~ 0.4724 in.)
Service Limit	11.96 mm (0.4709 in.)

- Using a cylinder gauge, measure the diameter of the both of piston pin holes in the piston and the inside diameter of the connecting rod small end.
- If either piston pin hole diameter exceeds the service limit, replace the piston.

Piston Pin Hole Diameter

Standard	12.001 ~ 12.011 mm (0.4725 ~ 0.4729 in.)
Service Limit	12.08 mm (0.4756 in.)

- If the connecting rod small end inside diameter exceeds the service limit, replace the crankshaft assembly.

Connecting Rod Small End Inside Diameter

Standard	16.002 ~ 16.013 mm (0.630 ~ 0.6304 in.)
Service Limit	16.05 mm (0.6319 in.)

- Check the needle bearing.

NOTE

- *The rollers in a needle bearing normally wear very little, and wear is difficult to measure. Instead of measuring, inspect the bearing for abrasion, color change or other damage.*
- If there is any doubt as to the condition of a needle bearing, replace the bearing and piston pin.

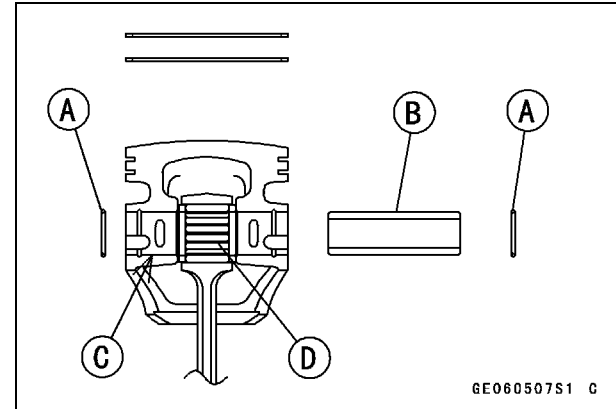

- A. Snap Ring
- B. Piston Pin
- C. Piston Pin Hole
- D. Needle Bearing

Piston Installation

- Install all parts in the reverse order of removal.
- Stuff a clean cloth into the crankcase opening around the connecting rod so that no parts will fall into the crankcase.
- Scrape any carbon off of the piston, then lightly polish the piston with fine emery cloth.
- Clean carbon and dirt out of the piston ring grooves using a suitable tool.

68 MAINTENANCE AND ADJUSTMENT

NOTICE

Carbon particles can be very abrasive to piston rings. Don't allow such particles to fall onto the cylinder walls.

- When installing the piston ring on the piston, note the following:
- First fit one end of the piston ring against the pin in the ring groove, spread the ring opening with the other hand and then slip the ring into the groove.
- The top ring has a "1N" mark on its upper surface.
- The second ring has a "2N" mark on its upper surface.
- Install each ring so that the marked side faces upward.

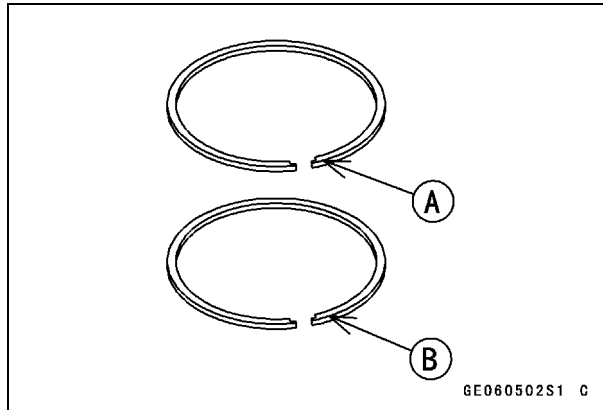

- A. "1N" Mark
- B. "2N" Mark

NOTE

- Install the piston ring so that the pin in the piston ring groove is between the ends of the piston ring.

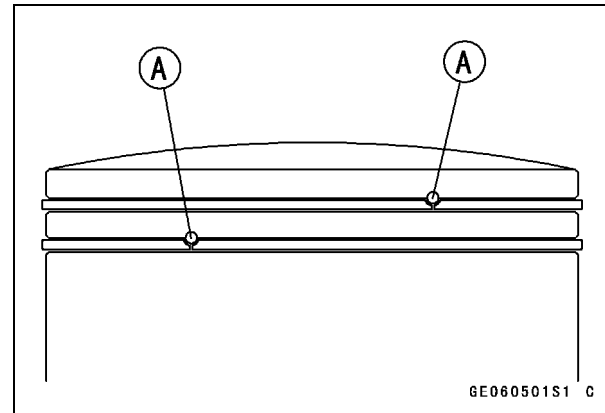

A. Pin

- Apply 2-stroke engine oil to the connecting rod needle bearing and the piston pin.
- Install the piston so that the “IN” mark faces toward the back (intake side) of the engine.

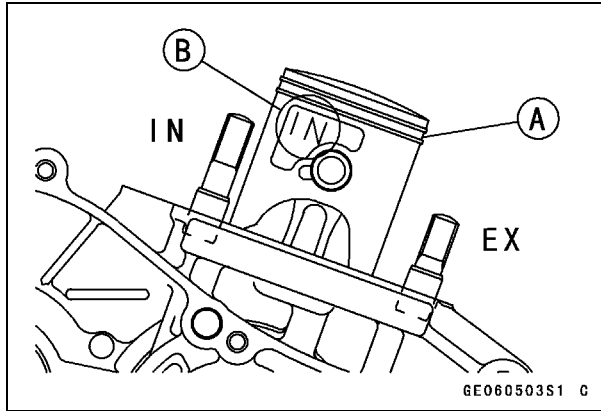

A. Piston
B. “IN” Mark

- When installing a piston pin snap ring, compress it only enough to install it and no more.

NOTICE

Do not reuse snap rings, as removal weakens and deforms them. They could fall out and score the cylinder wall.

- Fit a new piston pin snap ring into the side of the piston so that the snap ring ends do not coincide with the notch in the edge of the piston pin hole.

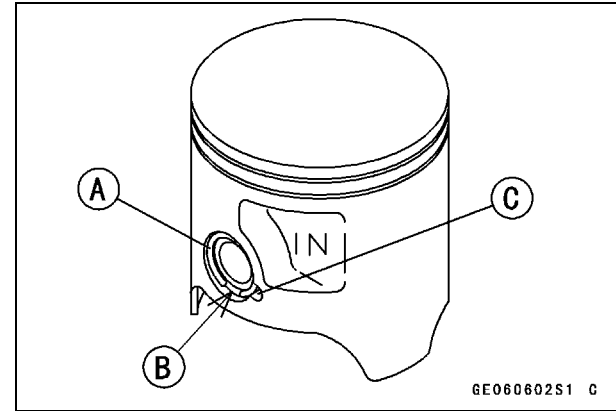

A. Snap Ring
B. Snap Ring Ends
C. Notch

Cylinder, Cylinder Head Installation

- Scrape any carbon out of the exhaust port.
- Check for mineral deposits and rust in the cylinder water jacket, and remove them if necessary.
- Replace the cylinder base gasket with a new one.
- Apply engine oil to the piston surface, piston rings and cylinder bore.
- Check that the pin in each piston ring groove is between cylinder over each ring, pressing in opposite sides of the piston rings as necessary. Be

70 MAINTENANCE AND ADJUSTMENT

certain that the piston rings do not slip out of position.

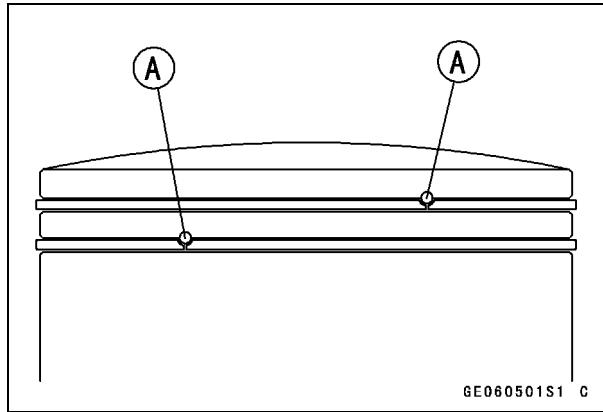

A. Pin

- Tighten the cylinder nuts to the specified torque in a crisscross pattern.

Cylinder Nut Tightening Torque

25 N·m (2.5 kgf·m, 18 ft·lb)

- Scrape out any carbon and clean the cylinder head with a high flash-point solvent.
- Check for mineral deposits and rust in the cylinder head water jacket, and remove them if necessary.
- Replace the cylinder head gasket with a new one.
- Install a new cylinder head gasket with the side marked “UP” facing up toward exhaust side.

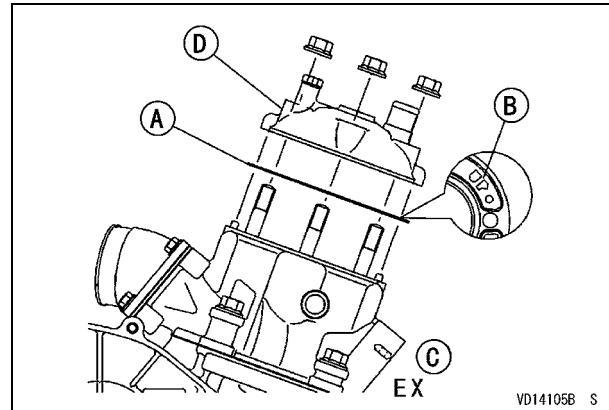

A. Cylinder Head Gasket

B. “UP” Mark

C. Exhaust Side

D. Cylinder Head

- Tighten the cylinder head nuts to the specified torque in a crisscross pattern.

Cylinder Head Nut Tightening Torque

25 N·m (2.5 kgf·m, 18 ft·lb)

- Install the spark plug.
- Connect the coolant hose to the cylinder head.
- When installing the carburetor, note the following:
- Being careful not to bend or otherwise damage the jet needle, align the groove in the throttle valve with the guide pin in the carburetor body.

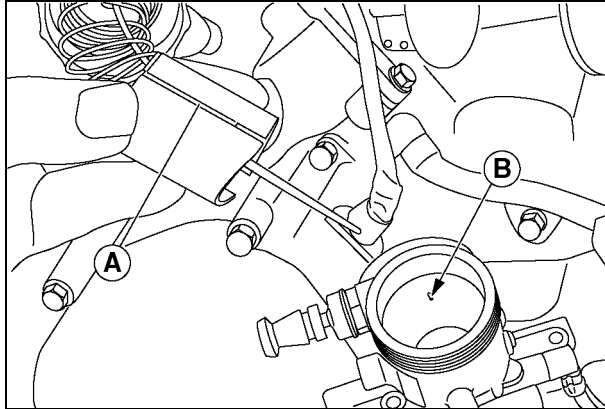

A. Groove
B. Guide Pin

- Check that the throttle valve goes all the way down into the carburetor body and slides smoothly.
- Fit the ridge on the carburetor body into the notch on the carburetor holder.

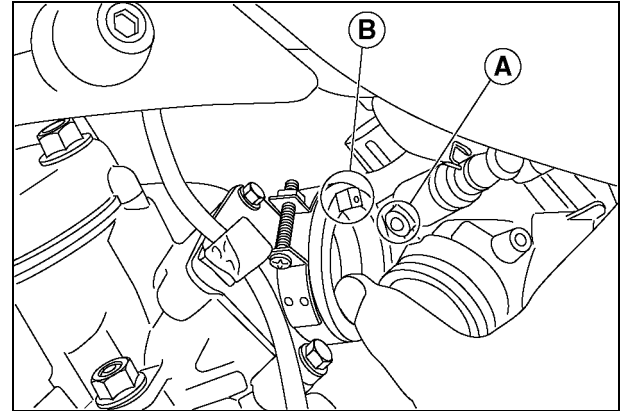

A. Ridge
B. Notch

- Tighten the clamp screw on the air cleaner joint and cylinder intake joint securely.
- Install the exhaust pipe, gasket, and muffler.
- Install the fuel tank, and tighten the fuel tank mounting bolt.
- Route the air vent hose and overflow hose through the clamp on the crankcase.

72 MAINTENANCE AND ADJUSTMENT

NOTICE

Always keep the hoses free from obstruction, and make sure they do not get pinched by the chain or shock absorber.

- Turn the fuel tap lever to the ON position, and check for fuel leakage from the carburetor.
- Install the parts removed.
- Fill the radiator up to the bottom of the radiator filler neck with coolant (See the “Cooling System” chapter).
- Check the coolant level.

Exhaust System

The exhaust system, in particular the muffler, is designed to reduce exhaust noise and conduct the exhaust gases away from the rider while minimizing power loss. If carbon has built up inside the muffler, exhaust efficiency is reduced, causing engine performance to drop.

If the muffler is badly damaged, dented, cracked or rusted, replace it. Replace the silencer packing if the exhaust noise becomes too loud or engine performance drops.

Silencer Packing Replacement

- Remove the right side cover.
- Remove the muffler bolts and pull the muffler off toward the rear.

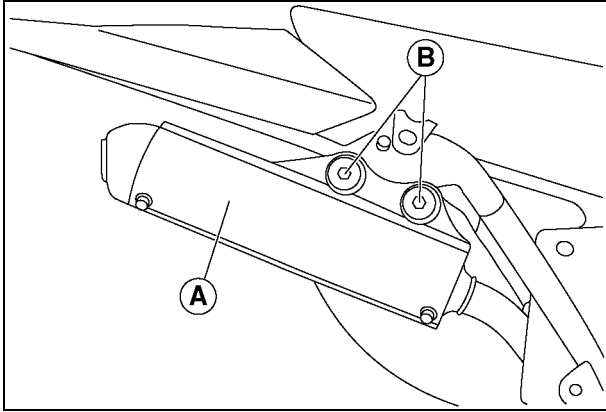

A. Muffler
B. Bolts

- Remove the inner pipe bolts of the front end and rear end of the muffler, and pull out the tail pipe.

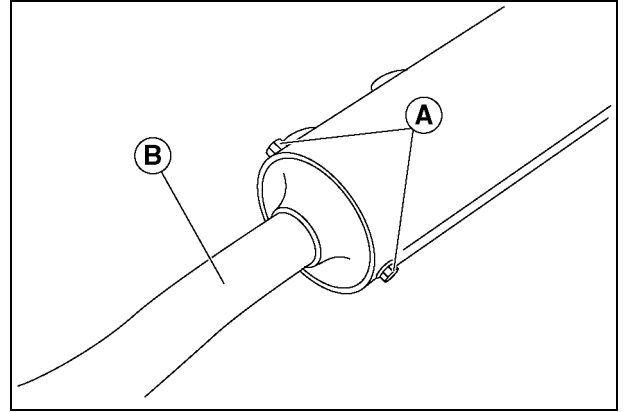

A. Bolts
B. Muffler Pipe

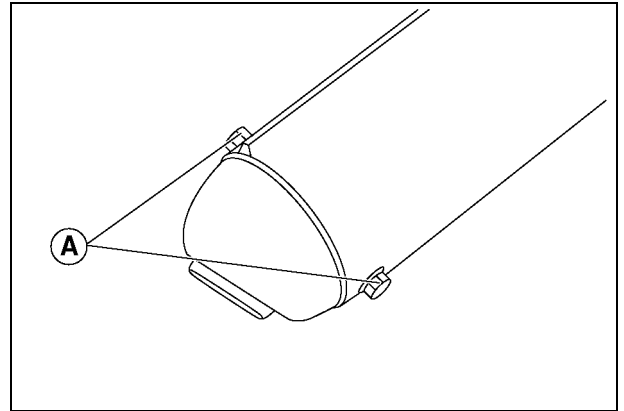

A. Bolts

74 MAINTENANCE AND ADJUSTMENT

- Pull off the old silencer wool, and install the new one.

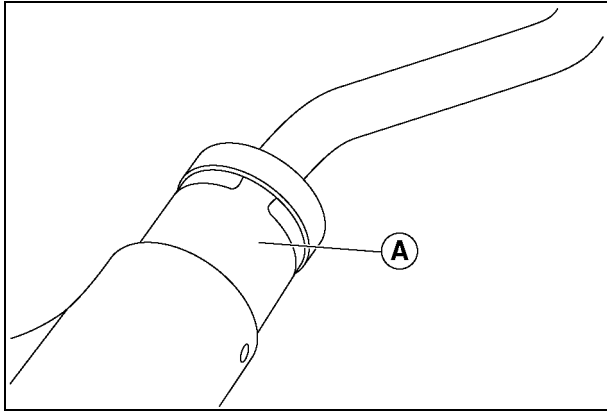

A. Silencer Wool

- Install the tail pipe into the muffler.
- Apply silicone sealant to the front end and rear end of the muffler.
- Tighten the bolts applied the non-permanent locking agent.
- Install the muffler and right side cover.

Drive Chain

For safety and to prevent excessive wear, the drive chain must be checked, adjusted, and lubricated in accordance with the Periodic Maintenance Chart. If the chain becomes badly worn or maladjusted—either too loose or too tight—it could jump off the sprockets or break.

⚠ WARNING

A chain that breaks or jumps off the sprockets could snag on the engine sprocket or lock the rear wheel, severely damaging the motorcycle and causing it to go out of control. Inspect the chain for damage and proper adjustment before each ride.

Chain Slack Inspection

- Raise the rear wheel off the ground, rotate the rear wheel to find the place where the chain is tightest (because it wears unevenly).
- Push up the drive chain in the middle of the upper chain run to measure the chain slack. The distance between the chain and the swingarm (at the end of the chain slipper) should be 45 ~ 55 mm (1.8 ~ 2.2 in.).
- Adjust the drive chain if its slack is out of specification.

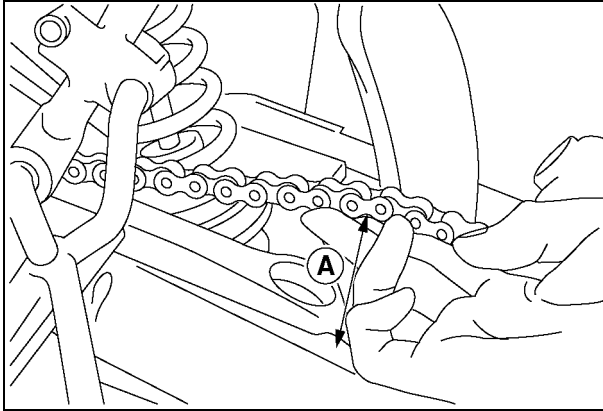

A. 45 ~ 55 mm (1.8 ~ 2.2 in.)

- In addition to checking the slack, rotate the rear wheel to inspect the drive chain for damaged rollers, loose pins and links and the sprockets for unevenly or excessively worn and damaged teeth.
- If there are any such defects, replace the drive chain and/or the sprockets.

Chain Slack Adjustment

- Remove the cotter pin from the rear axle nut.
- Loosen the rear axle nut and both chain adjuster locknuts.
- Turn both chain adjusting bolts evenly until the drive chain slack (measured between the chain and the swingarm) is 45 ~ 55 mm (1.8 ~ 2.2 in.).

For the rear wheel to be properly aligned, the rear end of the left chain adjuster should align with the same swingarm mark that the rear end of the right chain adjuster aligns with.

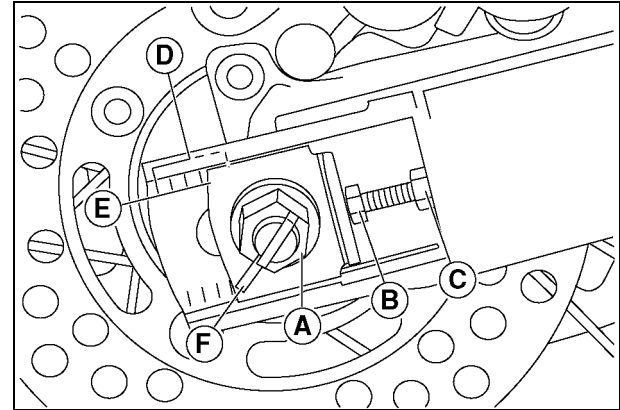

- A. Axle Nut**
- B. Adjusting Bolt**
- C. Locknut**
- D. Marks**
- E. Rear End of Chain adjuster**
- F. Cotter Pin**

NOTE

- *Wheel alignment can also be checked using the straightedge or string method.*

76 MAINTENANCE AND ADJUSTMENT

⚠ WARNING

Misalignment of the wheel will result in abnormal wear, and may result in an unsafe riding condition. Align the rear wheel using the marks on the swingarm or measuring the distance between the center of the axle and swingarm pivot.

- Tighten both chain adjuster locknuts.
- Torque the axle nut to 78 N·m (8.0 kgf·m, 58 ft·lb).
- Rotate the wheel, measure the chain slack again at the tightest position, and readjust it if necessary.
- Install a new cotter pin through the axle nut and axle, and spread its ends.

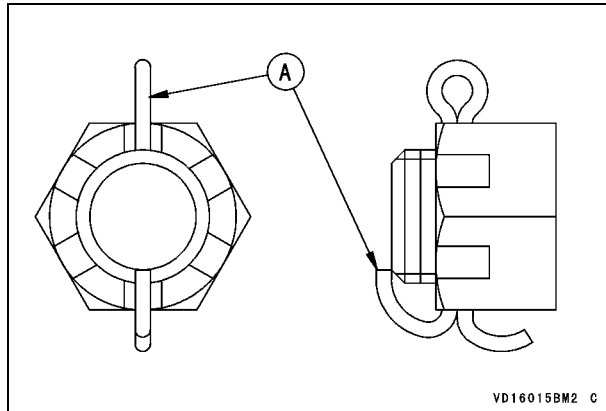

A. Cotter Pin

NOTE

- When inserting the cotter pin, if the slots in the nut do not align with the cotter pin hole in the axle shaft, tighten the nut clockwise to the next alignment.
- It should be within 30 degrees.
- Loosen once and tighten again when the slot goes past the nearest hole.

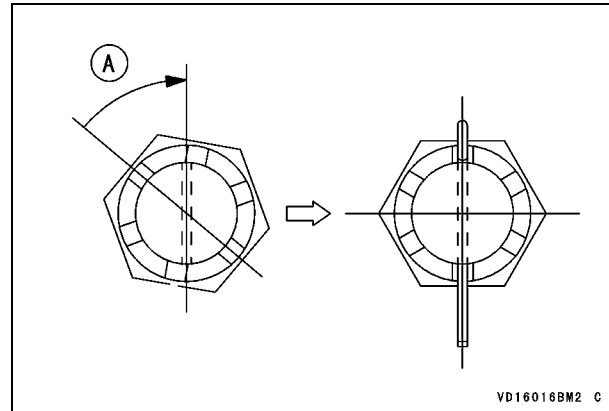

A. Turning Clockwise

⚠ WARNING

A loose axle nut can lead to an accident resulting in serious injury or death. Tighten the axle nut to the proper torque and install a new cotter pin.

NOTE

○ *When riding in wet and muddy conditions, mud sticks to the chain and sprockets, resulting in an overly tight chain, which can cause it to break. To prevent this, adjust the chain slack (measured between the chain and the swingarm) to 55 ~ 65 mm (2.1 ~ 2.6 in.).*

Chain Wear Inspection

When the chain has reached its wear limit (i.e., when it has stretched by 1.7% of its original length), it is no longer safe for use and should be replaced. Since it is impractical to measure the entire length of the chain, determine the degree of wear by measuring a 20-link section of the chain.

- Tighten the chain either by using the chain adjusters or by hanging a 10 kg (22 lb) weight on the chain.
- Measure the 20-link section on a straight part of the chain from the center of the 1st pin to the center of the 21st pin. If the length exceeds the service limit, the chain should be replaced. Since worn sprockets will cause a new chain to wear faster, inspect both the engine and rear sprockets whenever the chain is replaced, and replace them if necessary.

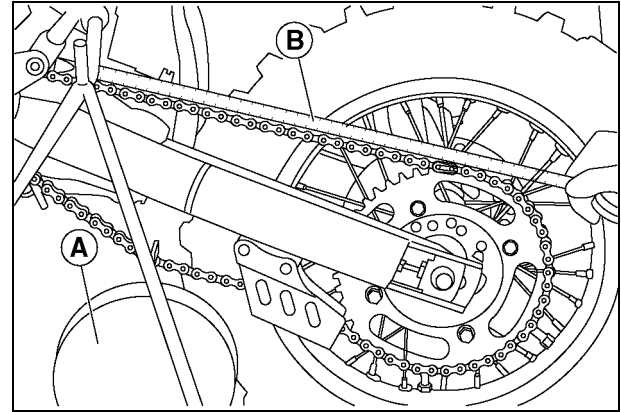

A. Weight
B. Tape Measure

Drive Chain 20-Link Section

Standard Length	254 mm (10.0 in.)
Wear Limit	258 mm (10.2 in.)

NOTE

- *The drive system was designed for use with a DAIDO D.I.D 420MBK1 110-link chain. For maximum stretch resistance and safety, a genuine part must be used for replacement.*
- *To minimize any chance of the master link coming apart, the master link clip must be installed with the closed end of the “U” pointing in the direction of chain rotation.*

78 MAINTENANCE AND ADJUSTMENT

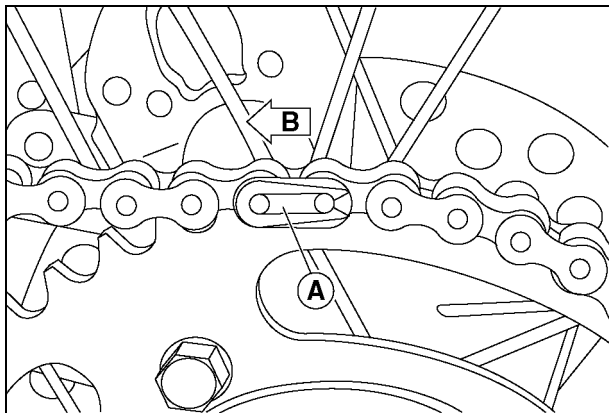

- A. Master Link Clip
- B. Direction of Rotation

Chain Guide Wear Inspection

- Visually inspect the drive chain guide and replace it if excessively worn or damaged.

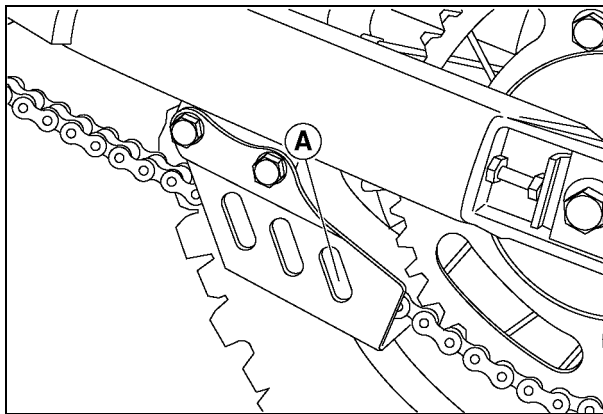

- A. Chain Guide

Chain Slipper Wear Inspection

- Visually inspect the upper and lower chain slippers on the swingarm and replace them if worn or damaged.

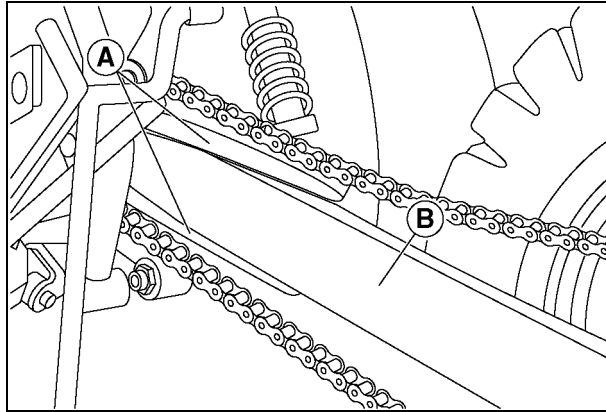

A. Chain Slippers
B. Swingarm

Sprocket Wear Inspection

- Visually inspect the sprocket teeth and replace the sprocket if its teeth are worn or damaged.

Sprocket Tooth Wear

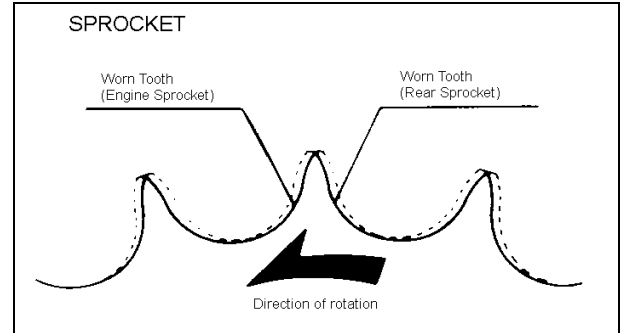

NOTE

- Sprocket wear is exaggerated in the illustration.

80 MAINTENANCE AND ADJUSTMENT

Chain Lubrication

Lubrication of the drive chain is necessary after riding in the rain or mud, or any time the chain appears dry with a high quality lubricant for drive chains.

- Apply lubricant to the side of the rollers so that it will penetrate to the rollers and bushings.
- Wipe off any excess lubricant.

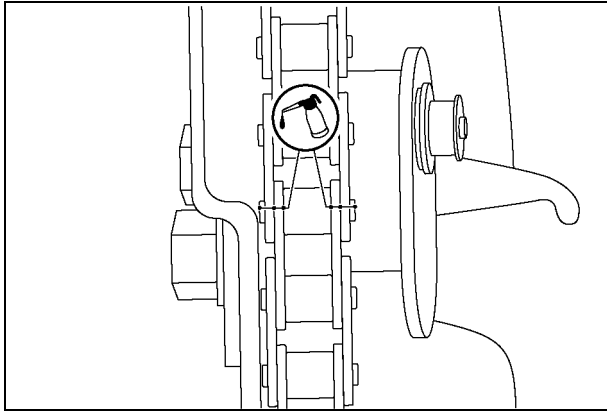

Handlebar

To keep the handlebar properly secured in place, it is necessary to install the handlebar clamps correctly.

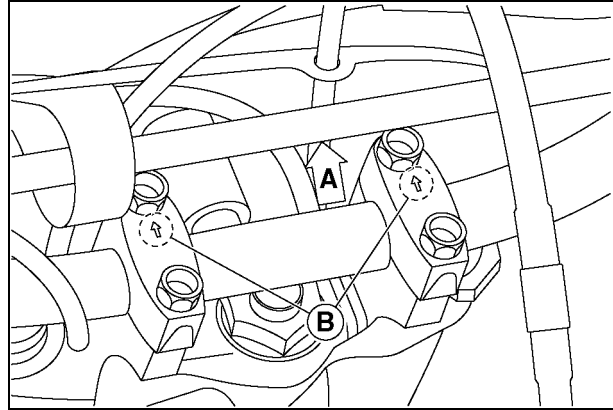

- A. Front
- B. Arrow Mark

- Torque the clamp bolts to 25 N·m (2.5 kgf·m, 18 ft·lb), front first, then rear. If the handlebar clamps are correctly installed, there will be no gap at the front and an even gap at the rear of the clamps after torquing the bolts.

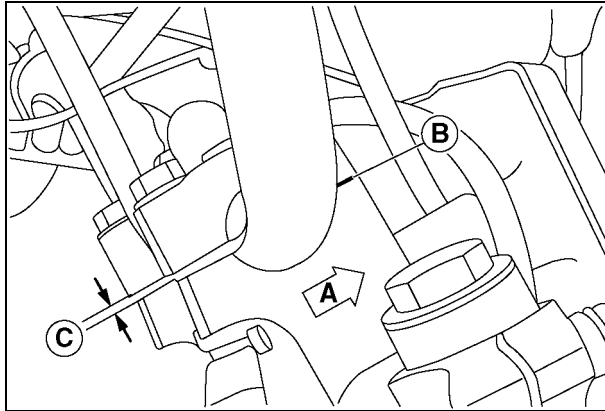

- A. Front
- B. No Gap
- C. Gap

Brakes

Disc and disc pad wear is automatically compensated for and has no effect on the brake lever or pedal action. There are no parts on the brakes that require adjustment except brake lever position.

Brake Lever Position

The brake lever position can be adjusted to suit the rider's preference.

- To adjust the brake lever position, loosen the locknut, and turn the adjuster to either side with a wrench.
- After adjustment, tighten the locknut securely.

⚠ WARNING

An improperly adjusted brake could drag and cause the brake to overheat, damaging the brake assembly and possibly locking the rear wheel, resulting in loss of control. Always maintain the proper brake adjustment.

82 MAINTENANCE AND ADJUSTMENT

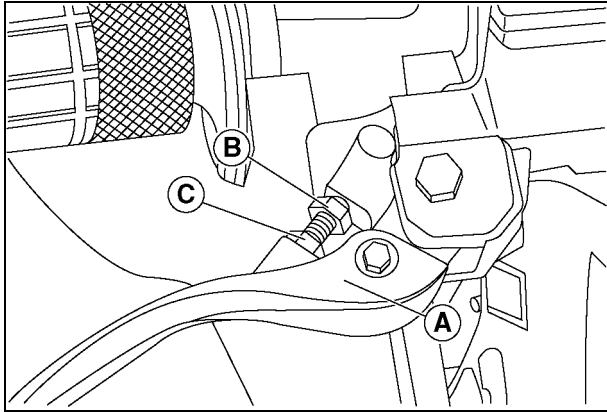

- A. Brake Lever
- B. Adjuster
- C. Locknut

- Test the braking power and check that there is no brake drag.

⚠ WARNING

Air in the brake lines diminish braking performance and can cause an accident resulting in injury or death. If the brake lever or pedal feels mushy when it is applied, there might be air in the brake lines or the brake may be defective. Have the brake checked immediately by an authorized Kawasaki dealer.

Disc Brake Fluid

Inspect the brake fluid level in the front and rear reservoirs and change the brake fluid in accordance with the Periodic Maintenance Chart. The brake fluid should also be changed when contaminated with dirt or water.

Use only heavy-duty brake fluid as follows.

- Front brake fluid : DOT 3 or DOT 4
- Rear brake fluid : DOT 4

NOTE

- *The motorcycle is shipped with brake fluid DOT4 in the brake system.*

NOTICE

Do not spill brake fluid onto any painted surface.

Do not use fluid from a container that has been left open or that has been unsealed for a long time.

Check for fluid leakage around the brake system fittings.

Check for brake hose damage.

Brake Fluid Level Inspection*Front Reservoir*

With the front reservoir positioned horizontally, the brake fluid must always be above the minimum level line.

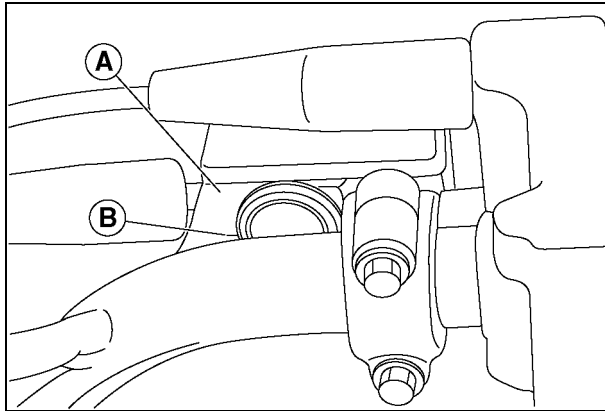

A. Front Reservoir
B. Minimum Level Line

- If the brake fluid in the front reservoir is below the minimum level line, check for fluid leaks in the brake line and fill the reservoir to the maximum level line (The step inside the front reservoir indicates the maximum level).

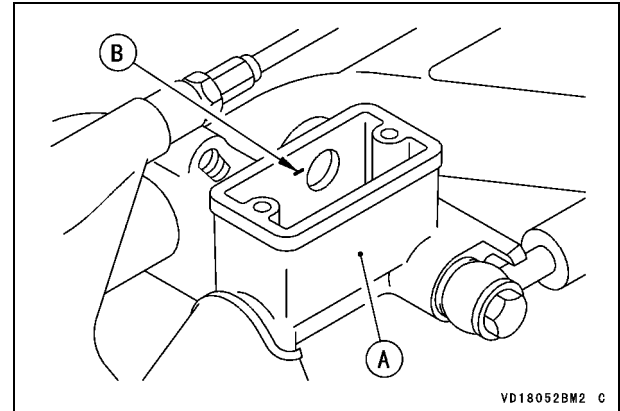

A. Front Reservoir
B. Maximum Level Line

84 MAINTENANCE AND ADJUSTMENT

Rear Reservoir

Positioned horizontally, the rear reservoir must always be more than half full.

- Remove the right side cover.
- If the amount of brake fluid is insufficient, check for fluid leaks in the brake line and add brake fluid.

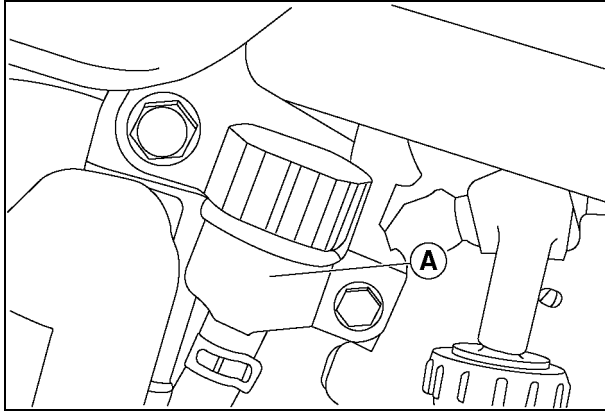

A. Rear Reservoir

⚠ WARNING

Mixing brands and types of brake fluid can reduce the brake system's effectiveness and cause an accident resulting in injury or death. Do not mix two brands of brake fluid. Change the brake fluid in the brake line completely if the brake fluid must be refilled but the type and brand of the brake fluid that is already in the reservoir are unidentified.

Brake Pad Wear Inspection

Inspect the brake pads for wear in accordance with the Periodic Maintenance chart. If the thickness of any pad in any (front or rear) brake caliper is less than 1 mm (0.04 in.), have both pads in the caliper replaced as a set. Pad replacement should be done by an authorized Kawasaki dealer.

Usable Brake Pad Range

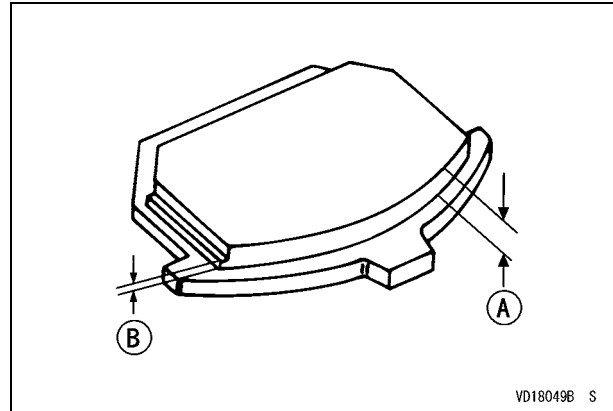

A. Lining Thickness

B. 1 mm (0.04 in.)

VD18049B S

Steering

The steering should always be kept adjusted so that the handlebar will turn freely but not have excessive play.

Steering Inspection

- To check the steering adjustment, raise the front wheel off the ground using a jack (special tool).
- Push the handlebar lightly to either side. If the handlebar continues moving under its own momentum, the steering is not too tight.
- Squatting in front of the motorcycle, grasp the lower ends of the front fork at the axle, and push and rock the front fork back and forth as shown. If play is felt, the steering is too loose and needs to be adjusted.

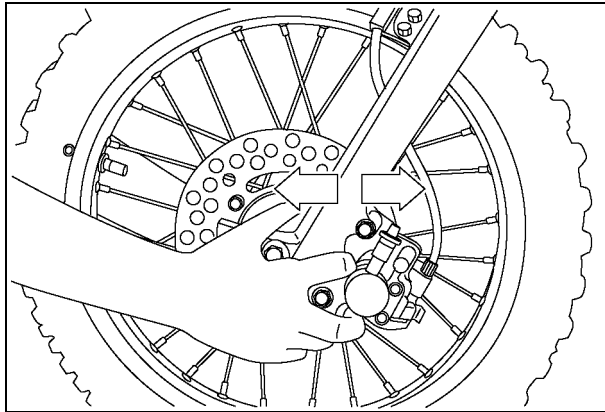

Steering Adjustment

- Loosen the number plate.
- Raise the front wheel off the ground using a jack (special tool).
- Remove the handlebar clamps and handlebar.
- Loosen the steering stem head nut, and the front fork lower clamp bolts.
- Turn the steering stem locknut with a stem nut wrench (special tool) to obtain the proper adjustment.

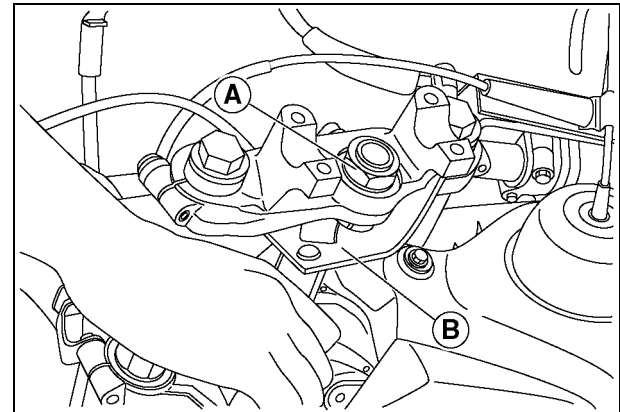

A. Stem Head Nut

B. Steering Stem Nut Wrench (P/No. 57001-1100)

- Apply the specified torque to the stem head nut and front fork lower clamp bolts.
- Install the handlebar and handlebar clamps correctly, and apply the specified torque 25 N·m (2.5 kgf·m, 18 ft·lb) to the handlebar clamp bolts.

86 MAINTENANCE AND ADJUSTMENT

Steering Stem Head Nut Tightening Torque

44 N·m (4.5 kgf·m, 33 ft·lb)

Lower Clamp Bolt Tightening Torque

29 N·m (3.0 kgf·m, 22 ft·lb)

- Check the steering again and readjust it if necessary.
- Tighten the number plate.

Front Fork

NOTICE

Sticking muds or dusts on the sliding surface of the front fork could damage to the oil seal, leading to an oil leak. Clean the sliding surface after each ride.

Any of the following front fork adjustments should be made to tune the front suspension to the rider's weight and the condition of the track.

Basically, there are four adjustments you can make to the front fork.

- Fork Oil Level Adjustment

The fork oil level affects only the final 100 mm (4 in.) of fork travel. A higher oil level will make the fork rebound more quickly. A lower oil level will make the fork rebound more slowly.

- Fork Springs

Optional springs, softer and stiffer than standard, are available.

- Fork Height

Steering is greatly affected by the fork height (how much the outer fork tubes protrude above the upper fork clamp). The less the fork tube protrudes, the lighter the front end becomes and the greater the tendency for understeering and washout due to weight biasing. Increasing the amount of fork tube protrusion has opposite effects. Be sure that the front tire does not touch the fender when the fork

is fully compressed. Make this adjustment in 10 mm (0.4 in.) steps.

● **Rebound Damping Adjustment**

This adjustment affects how quickly the fork rebounds. Depending on the model, the fork rebound damping adjuster has 4 positions. The fully seated position (adjuster turned fully clockwise) is the hardest setting. Turning the adjuster 3 clicks counterclockwise from the fully seated position is the standard setting, turning it out 4 or more clicks (depending on the model) is the softest setting.

NOTICE

The right and left fork tubes must be adjusted evenly.

Rebound Damping Adjustment

● To adjust the rebound damping, turn the adjuster on each front fork top plug with a flat-head screwdriver. Adjust the rebound damping to suit your preference under certain conditions.

NOTICE

Do not force the rebound damping force adjusters beyond the fully seated position, or the adjusting mechanism may be damaged.

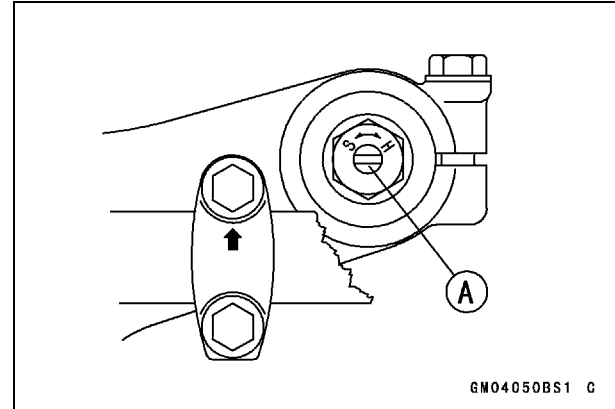

A. Rebound Damping Adjuster

Rebound Damping Adjuster Settings

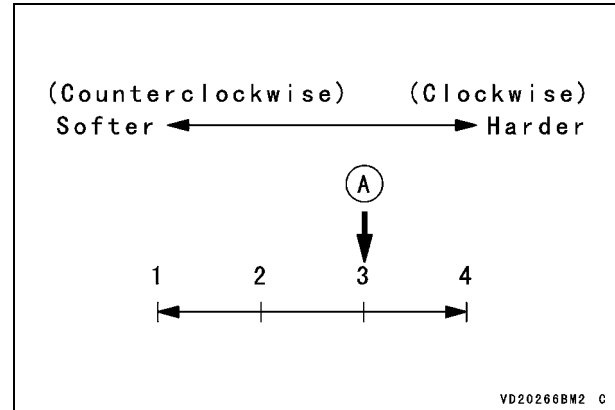

A. Standard Position

88 MAINTENANCE AND ADJUSTMENT

Standard Rebound Damping Adjuster Setting

3 clicks*

*Out from the fully seated position (Adjuster Turned Fully Counterclockwise)

NOTICE

The right and left fork tubes must be adjusted evenly.

Fork Oil Level Adjustment

- Raise the front wheel off the ground using a jack (special tool).
- Remove the number plate.
- Loosen the upper fork clamp bolts.
- Remove the handlebar by removing the handlebar clamp bolts.
- Remove the front fork top plug, fork spring and fork spring set.

WARNING

The top plugs are under extreme spring pressure and may eject with great force during service. Use care when removing the top plugs. Wear eye and face protection.

- Check both top plug O-rings for damage and replace them if necessary.

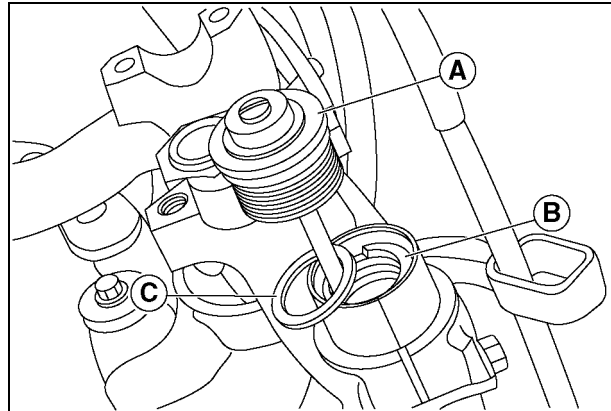

- A. Top Plug**
- B. Fork Spring**
- C. Fork Spring Seat**

- Slowly compress the front fork fully by pushing up the outer tubes using a jack or other suitable means under the front wheel.
- Place a stand or other suitable support under the front wheel.

MAINTENANCE AND ADJUSTMENT 89

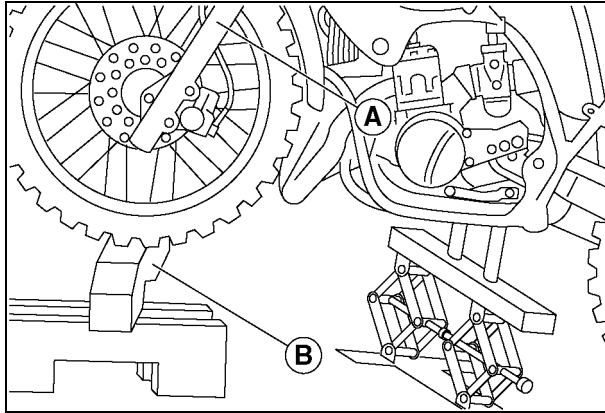

A. Outer Tube
B. Stand

- With the fork in this position, attach the oil level gauge (special tool) to the top of the fork tube, and measure the distance from the top of the inner tube to the oil level.

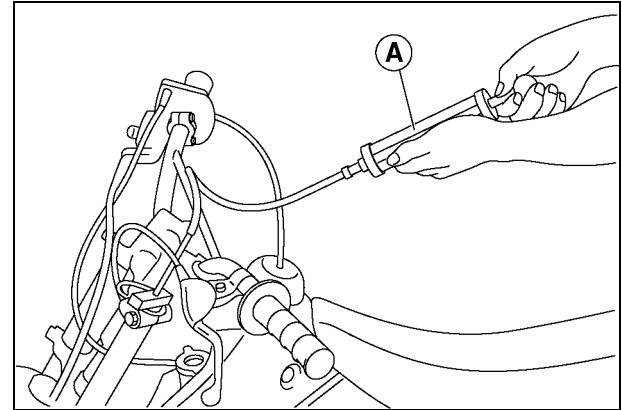

A. Oil Level Gauge (P/No. 57001-1290)

- Adjust the fork oil level as required within the adjustable range using one of the following springs.

90 MAINTENANCE AND ADJUSTMENT

Fork Oil Level

Fork Spring	Standard Level	Adjustable Range
K = 2.45 N/mm	140 mm (5.50 in.)	106 ~ 150 mm (4.17 ~ 5.9 in.)
K = 2.55 N/mm	135 mm (5.30 in.)	101 ~ 145 mm (3.98 ~ 5.71 in.)
K = 2.65 N/mm	132 mm (5.20 in.)	98 ~ 142 mm (3.86 ~ 5.60 in.)
K = 2.75 N/mm	133 mm (5.24 in.)	99 ~ 143 mm (3.90 ~ 5.63 in.)
K = 2.84 N/mm	131 mm (5.16 in.)	97 ~ 141 mm (3.82 ~ 5.55 in.)

Suspension Oil

SS8 (1 L): P/No. 44091-0007

- Install the fork spring with thinner side toward under side.

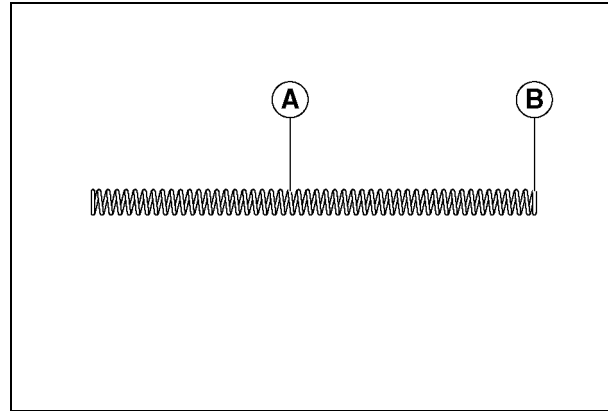

- A. Fork Spring**
- B. Thinner Side**

- Install the top plug and fork spring seat and tighten the top plug to 22.5 N·m (2.3 kgf·m, 16.6 ft·lb).
- Assemble the other fork tube in the same way as described above.
- Torque the upper fork clamp bolts to 20 N·m (2.0 kgf·m, 14.5 ft·lb).
- Install the handlebar, and tighten the handlebar clamp bolts to 25 N·m (2.5 kgf·m, 18 ft·lb).
- Install the parts removed.

Optional Fork Springs

Various fork springs are available to achieve suitable front fork action in accordance with the rider's weight and track condition.

Harder springs stiffen the fork action and accelerate the rebound damping.

Softer springs soften the fork action and slow down the rebound damping.

Fork Height Adjustment

Steering is greatly affected by the fork height (how much the outer fork tubes protrude above the upper fork clamp). The less the fork tube protrudes, the lighter the front end becomes and the greater the tendency for understeering and washout due to weight biasing. Increasing the amount of fork tube protrusion has opposite effects.

Be sure that the front tire does not touch the fender when the fork is fully compressed. Make this adjustment in 10 mm (0.39 in.) steps.

NOTICE

The right and left fork tubes must be adjusted evenly.

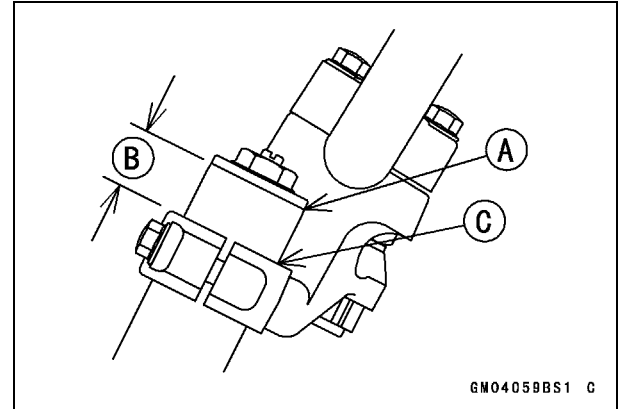

- A. Outer Tube Topend**
- B. Standard Fork Height**
- C. Upper Surface**

Standard Fork Height

20 mm (0.79 in.)*

*Below the top of the outer tube.

Rear Suspension (UNI-TRAK®)

NOTICE

Sticking muds or dusts on the sliding surface of the rear shock absorber could damage to the oil seal, leading to an oil leak. Clean the sliding surface after each ride.

This motorcycle's rear suspension system is called "UNI-TRAK®" and consists of a rear shock absorber unit, a swingarm, two lever rods and a lever.

The operating characteristics of the UNI-TRAK® suspension are similar to those of the front fork. However, a linkage system is used to achieve progressive springing characteristics.

The spring preload of the shock absorber can be adjusted or the spring can be replaced with an optional one to suit various riding conditions. In addition, the damping force can be adjusted easily, making it unnecessary to change the oil viscosity.

Rebound Damping Adjustment

To adjust the rear shock absorber rebound damping, turn the rebound damping adjuster at the bottom

of the rear shock absorber with a flat-head screwdriver.

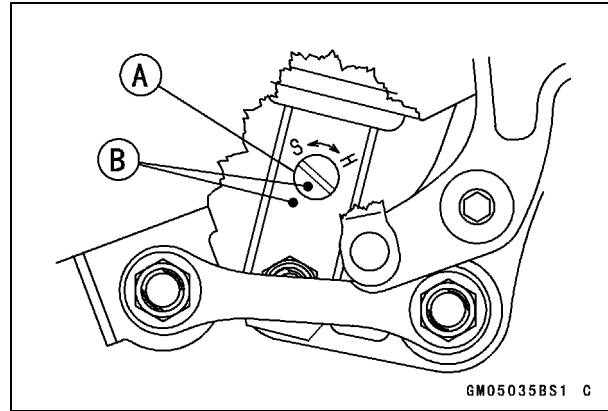

- A. Rebound Damping Adjuster
- B. Punch Mark

If the damping feels too soft or too stiff, adjust it in accordance with the following table.

Rebound Damping Adjuster Settings

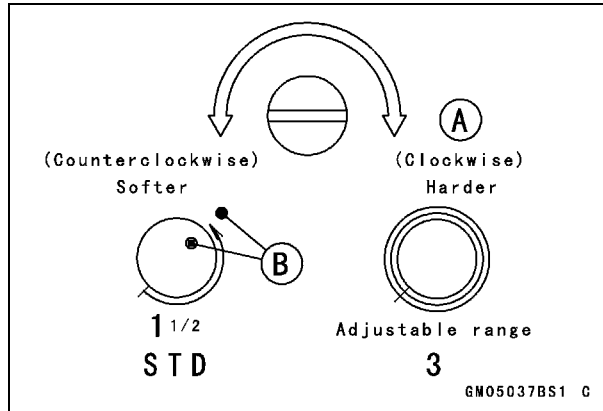

- A. Seated Position (Adjuster Turned Fully Clockwise)
- B. Punch Mark

Standard Rebound Damping Adjuster Setting

1 1/2 turns out*

*Out from the fully seated position

NOTE

- The punch mark position of your rear shock absorber may be different from the illustration.

Spring Preload Adjustment

- Set up the side stand.
- Remove the seat and both side covers.
- Loosen the air intake duct clamp screw.
- Remove the air cleaner case bolts.
- Remove the rear frame and air cleaner case.

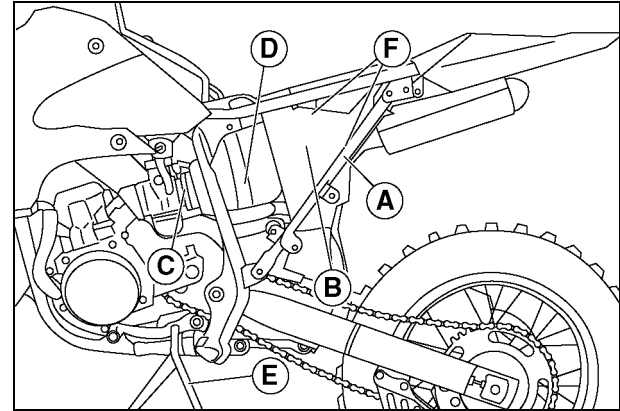

- A. Rear Frame
- B. Air Cleaner Case
- C. Clamp
- D. Air Intake Duct
- E. Side Stand
- F. Air Cleaner Case Bolts

- Raise the rear wheel off the ground using a jack (special tool).
- Using the hook wrenches (special tools), loosen the locknut and turn the adjusting nut as required. Turning the adjusting nut down increases the spring preload.

94 MAINTENANCE AND ADJUSTMENT

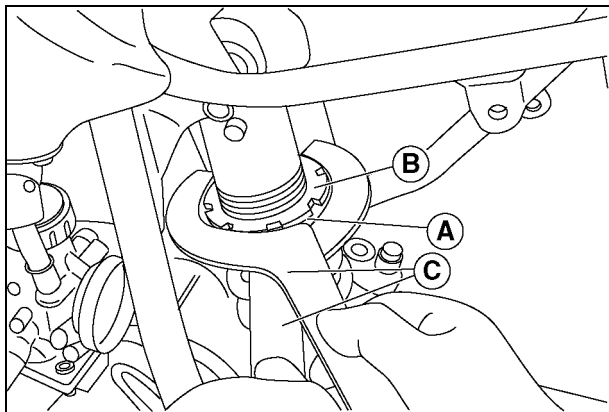

- A. Adjusting Nut**
- B. Locknut**
- C. Hook Wrenches (P/No.57001-1101)**

- The standard adjusting nut position from the center of the upper mounting hole and the adjustable range is as follows:

Rear Shock Absorber Spring	Nut Position	Adjustable Range
K = 48 (standard) N/mm	79.6 mm (3.13 in.)	75.6 ~ 83.6 mm (2.98 ~ 3.30 in.)
K = 44 N/mm		75.6 ~ 84.6 mm (2.98 ~ 3.33 in.)
K = 46 N/mm		75.6 ~ 88.6 mm (2.98 ~ 3.49 in.)
K = 50 N/mm		75.6 ~ 86.6 mm (2.98 ~ 3.41 in.)

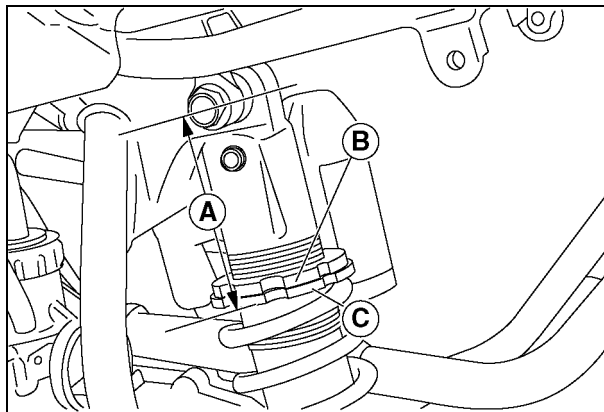

- A. Adjusting Nut Position**
- B. Locknut**
- C. Adjusting Nut**

- Tighten the locknut securely.
- After making the adjustment, move the spring up and down to make sure that it is properly seated.
- Install the parts removed.
- Tighten the rear frame mounting bolt to 34 N·m (3.5 kgf·m, 25 ft·lb).

Optional Rear Shock Absorber Springs

Various rear shock absorber springs are available to achieve suitable rear shock absorber action in accordance with the rider's weight and track condition.

A harder spring stiffens the shock absorber action and accelerates the rebound damping.

A softer spring softens the shock absorber action and slows down the rebound damping.

WARNING

Improper removal or installation of the rear shock absorber spring may cause the spring and/or related parts to be ejected at high velocity. Always wear eye and face protection when working on the rear shock absorber. Removal and installation of the rear shock absorber spring should be performed by an authorized Kawasaki dealer.

Wheels

Tire Air Pressure

Tire air pressure affects traction, handling, and tire life. Adjust the tire air pressure to suit track conditions and rider preference, but keep it close within the recommended range.

- Reduce the tire air pressure to increase the tire tread surface on the ground when riding on a wet, muddy, sandy or slippery track.
- Increase the tire air pressure to prevent damage or punctures (though the tires will skid more easily) when riding on a pebbly or hard track.

Tire Air Pressure Adjustable Range

80 kPa (0.8 kgf/cm ² , 11 psi) ~ 100 kPa (1.0 kgf/cm ² , 14 psi)

NOTE

- *Tire air pressure should be checked when the tires are cold, before you ride the motorcycle.*

96 MAINTENANCE AND ADJUSTMENT

Spokes and Rims

The spokes on both wheels must all be securely and evenly tightened and not be allowed to loosen. Unevenly tightened or loose spokes will cause the rim to warp, the nipples and spokes to fatigue more quickly, and the spokes to break.

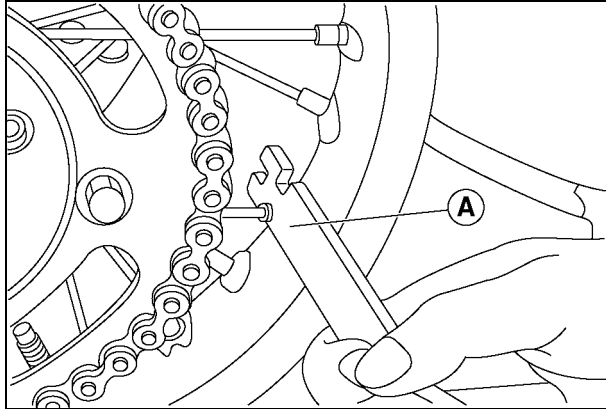

A. Spoke and Spark Plug Wrench

Bead Protector

There is a bead protector on the rear wheel. The bead protector prevents the tire and tube from slipping on the rim and damaging the valve stem. Valve stem damage may cause the tube to leak, necessitating tube replacement. In order to keep the tire and tube in position on the rim, inspect the bead protector before riding and tighten it if necessary. Tighten the valve stem nut finger tight only.

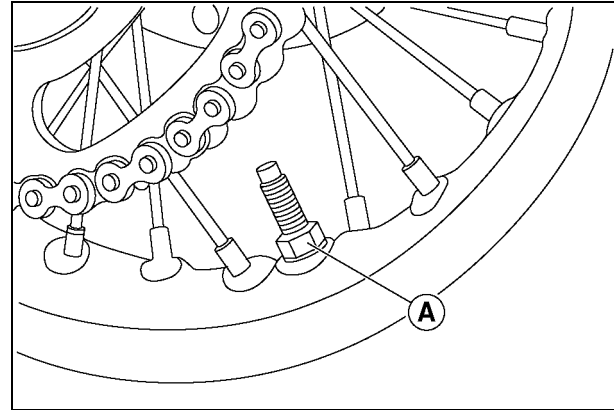

A. Bead Protector Nut

Rim Runout

Set up a dial gauge on the side of the rim and rotate the wheel to measure its axial runout. The difference between the highest and lowest readings is the amount of runout.

- Set up the dial gauge on the inner circumference of the rim and rotate the wheel to measure its radial runout. The difference between the highest and lowest readings is the amount of runout.
- A certain amount of rim warpage (runout) can be corrected by recentering the rim, that is, by loosening some spokes and tightening other to change the position of certain portions of the rim. If the rim is badly bent, however, it should be replaced.

NOTE

○ *The welding spot of the rim may show excessive runout. Disregard this when measuring runout.*

Rim Runout

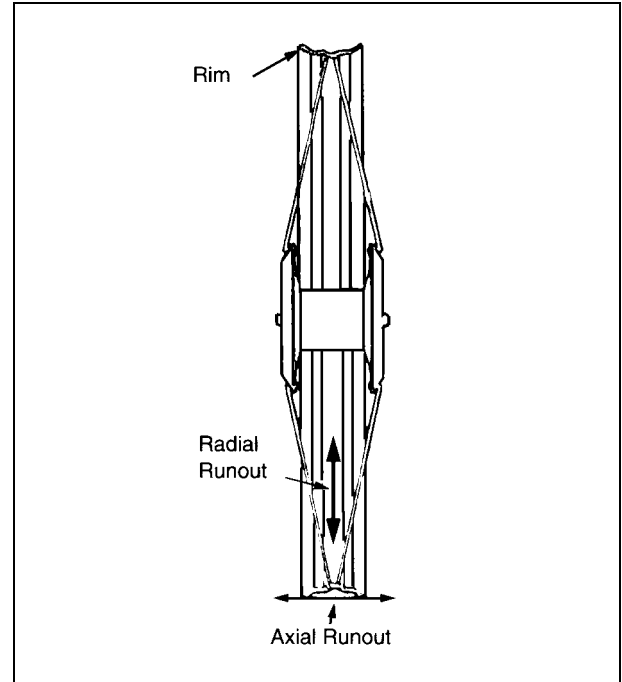

Rim Runout Maximum Limit

Axial	2.0 mm (0.08 in.)
Radial	

98 MAINTENANCE AND ADJUSTMENT

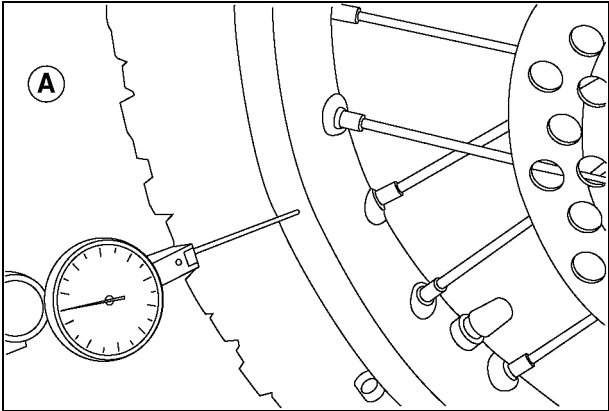

A. Axial Rim Runout Measurement

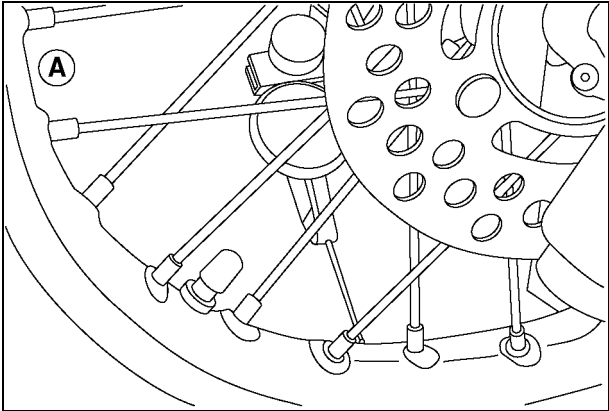

A. Radial Rim Runout Measurement

Tightening Torques of Nuts and Bolts

Location of nuts and Bolts

Before the first ride of each day of operation, check the tightness of the nuts and bolts listed below. Check also that all cotter pins are in place and in good condition.

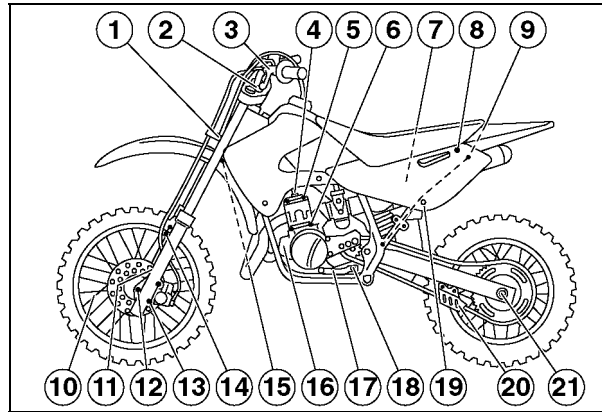

- | | |
|-----------------------------|-----------------------------------|
| 1. Front Fork Clamp Bolts | 12. Front Axle Nut |
| 2. Handlebar Clamp Bolts | 13. Brake Caliper Bolts |
| 3. Clutch Lever Holder Bolt | 14. Brake Hose Holder Bolts |
| 4. Spark Plug | 15. Front Fender Bolts |
| 5. Cylinder Head Nuts | 16. Radiator Bolts |
| 6. Cylinder Nuts | 17. Engine Mounting Bolt and Nuts |
| 7. Air Cleaner Case Bolts | 18. Shift Pedal Bolts |
| 8. Seat Bolt | 19. Side Cover Mounting Bolts |
| 9. Rear Frame Bolts | 20. Chain Guide Bolts |
| 10. Spokes | 21. Chain Adjuster Locknut |
| 11. Brake Disc Bolts | |

100 MAINTENANCE AND ADJUSTMENT

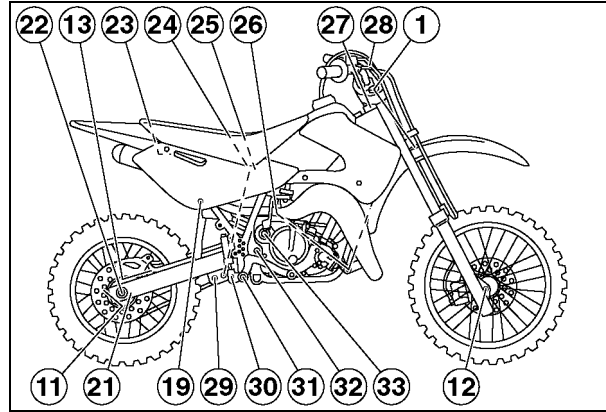

- 22. Rear Axle Nut
- 23. Muffler Bolts
- 24. Rear Shock Absorber Bolt and Nut
- 25. Rear Brake Reservoir Bolt or Screw
- 26. Expansion Chamber Damper Mounting Bolt and Nut
- 27. Steering Stem Head Nut
- 28. Brake Lever Holder Bolt
- 29. UNI-TRAK® Tie-rod Mounting Nuts
- 30. UNI-TRAK® Rocker Arm Mounting Nut
- 31. Rear Brake Pedal Mounting Bolt
- 32. Swingarm Pivot Shaft Nut
- 33. Kick Pedal Bolt

Torque Table

Tighten all nuts and bolts to the proper torque using an accurate torque wrench. An insufficiently tightened nut or bolt may become damaged or fall out, possibly resulting in damage to the motorcycle and injury to the rider. An overtightened nut or bolt may become damaged, broken, or fall out.

Part Name		N·m	kgf·m	ft·lb
ENGINE	Air Bleeder Bolt	8.8	0.9	(78 in·lb)
	Cylinder Head Nuts	25	2.5	18
	Cylinder Nuts	25	2.5	18
	Transmission Oil Drain Plug	20	2.0	14.5
	Kick Pedal Bolt	12	1.2	(106 in·lb)
	Shift Pedal Bolt	8.8	0.9	(78 in·lb)
	Spark Plug	25.5	2.55	18.8
	Coolant Drain Plug (Water Pump)	8.8	0.9	(78 in·lb)
	Impeller Bolt	8.3	0.85	(74 in·lb)
	Right Engine Cover Bolt	8.8	0.9	(78 in·lb)
	Water Pump Cover Bolt	8.8	0.9	(78 in·lb)
	Clutch Hub Bolt	64	6.5	47
	Clutch Spring Bolts	9.3	0.95	(82 in·lb)

102 MAINTENANCE AND ADJUSTMENT

Part Name		N·m	kgf·m	ft·lb	
CHASSIS	Brake Caliper Bolts	25	2.5	18	
	Brake Disc Bolts	9.8	1.0	(87 in·lb)	
	Engine Mounting Nuts	29.4	3.0	22	
	Front Axle	79	8.0	58	
	Front Fork Clamp Bolts	Upper	20	2.0	14.5
		Lower	29	3.0	22
	Front Fork Top Plug	22.5	2.3	16.6	
	Handlebar Clamp Bolts	25	2.5	18	
	Swingarm Pivot Shaft Nut	69	7.0	51	
	Rear Axle Nut	79	8.0	58	
	Rear Brake Pedal Mounting Bolt	25	2.5	18	
	Rear Frame Bolts	34	3.5	25	
	Rear Shock Absorber Bolt (Top)	39	4.0	29	
	Rear Shock Absorber Nut (Bottom)	34	3.5	25	
	Spokes	1.5	0.15	(13 in·lb)	
	Steering Stem Head Nut	44	4.5	33	
	Steering Stem Locknut	2.9	0.3	(26 in·lb)	
	UNI-TRAK® Rocker Arm Pivot Nut	83	8.5	61	
UNI-TRAK® Tie-rod Mounting Nuts	59	6.0	43		

Cleaning Your Motorcycle

General Precautions

Frequent and proper care of your Kawasaki motorcycle will enhance its appearance, optimize overall performance, and extend its useful life. Covering your motorcycle with a high quality, breathable motorcycle cover will help protect its finish from harmful UV rays, pollutants, and reduce the amount of dust reaching its surfaces.

WARNING

Build-up of debris or flammable material in and around the vehicle chassis, engine, and exhaust can cause mechanical problems and increase the risk of fire.

When operating the vehicle in conditions that allow debris or flammable material to collect in and around the vehicle, inspect the engine, electrical component and exhaust areas frequently. If debris or flammable materials have collected, park the vehicle outside and stop the engine. Allow the engine to cool, then remove any collected debris. Do not park or store the vehicle in an enclosed space prior to inspecting for build-up of debris or flammable materials.

- Be sure the engine and exhaust are cool before washing.

- Avoid applying degreaser to seals, brake pads, and tires.
- Always use non-abrasive wax and cleaner/polisher.
- Avoid all harsh chemicals, solvents, detergents, and household cleaning products such as ammonia-based window cleaners.
- Gasoline, brake fluid, and coolant will damage the finish of painted and plastic surfaces: wash them off immediately.
- Avoid wire brushes, steel wool, and all other abrasive pads or brushes.
- Use care when washing the plastic other parts as they can easily be scratched.
- Avoid using pressure washers; water can penetrate seals and electrical components and damage your motorcycle.
- Avoid spraying water in delicate areas such as in air intakes, carburetors, brake components, electrical components, muffler outlets, and fuel tank openings.

Washing Your Motorcycle

- Rinse your bike with cold water from a garden hose to remove any loose dirt.
- Mix a mild neutral detergent (designed for motorcycles or automobiles) and water in bucket. Use a soft cloth or sponge to wash your motorcycle. If needed, use a mild degreaser to remove any oil or grease build up.
- After washing, rinse your motorcycle thoroughly with clean water to remove any residue (residue

104 MAINTENANCE AND ADJUSTMENT

from the detergent can damage parts of your motorcycle).

- Use a soft cloth to dry your motorcycle. As you dry, inspect your motorcycle for chips and scratches. Do not let the water air dry as this can damage the painted surfaces.
- Start the engine and let it idle for several minutes. The heat from the engine will help dry moist areas.
- Carefully ride your motorcycle at a slow speed and apply the brakes several times. This helps dry the brakes and restores them to normal operating performance.
- Lubricate the drive chain to prevent rusting.

NOTE

- *After riding in an area where the roads are salted or near the ocean, immediately wash your motorcycle with cold water. Do not use warm water as it accelerates the chemical reaction of the salt. After drying, apply a corrosion protection spray on all metal and chrome surfaces to prevent corrosion.*

Semi-gloss Finish

To clean the semi-gloss finish;

- When washing the motorcycle, always use a mild neutral detergent and water.
- The semi-gloss finish effect may be lost when the finish is excessively rubbed.
- If any doubt, consult an authorized Kawasaki dealer.

Painted Surfaces

After washing your motorcycle, coat painted surfaces, both metal and plastic, with a commercially available motorcycle/automotive wax. Wax should be applied once every three months or as conditions require. Avoid surfaces with “satin” or “flat” finishes. Always use nonabrasive products and apply them according to the instructions on the container.

Plastic Parts

After washing use a soft cloth to gently dry plastic parts. When dry, treat the other non-painted plastic parts with an approved plastic cleaner/polisher product.

NOTICE

Plastic parts may deteriorate and break if they come in contact with chemical substances or household cleaning products such as gasoline, brake fluid, window cleaners, thread-locking agents, or other harsh chemicals. If a plastic part comes in contact with any harsh chemical substance, wash it off immediately with water and a mild neutral detergent, and then inspect for damage. Avoid using abrasive pads or brushes to clean plastic parts, as they will damage the part's finish.

Chrome and Aluminum

Chrome and uncoated aluminum parts can be treated with a chrome/aluminum polish. Coated

aluminum should be washed with mild neutral detergent and finished with a spray polish. Aluminum wheels, both painted and unpainted can be cleaned with special non-acid based wheel spray cleaners.

Leather, Vinyl, and Rubber

If your motorcycle has leather accessories special care must be taken. Use a leather cleaner/treatment to clean and care for leather accessories. Washing leather parts with detergent and water will damage them, shortening their life.

Vinyl parts should be washed with the rest of the motorcycle and then treated with a vinyl treatment.

The sidewalls of tires and other rubber components should be treated with a rubber protectant to help prolong their useful life.

⚠ WARNING

Rubber protectants can be slippery and, if used on the tread area, cause loss of traction resulting in accident causing injury or death. Do not apply rubber protectant to any tread area.

Lubrication

Lubricate the areas shown in the illustrations of this section, with either motor oil or regular grease, in accordance with the Periodic Maintenance Chart and whenever the vehicle has been operated under wet or rainy conditions, especially after using a high-pressure spray washer. Before lubricating a part, clean off any rust with rust remover and wipe off any grease, oil, dirt, or grime.

General Lubrication

Apply motor oil to the following pivots:

- Clutch lever
- Front brake lever

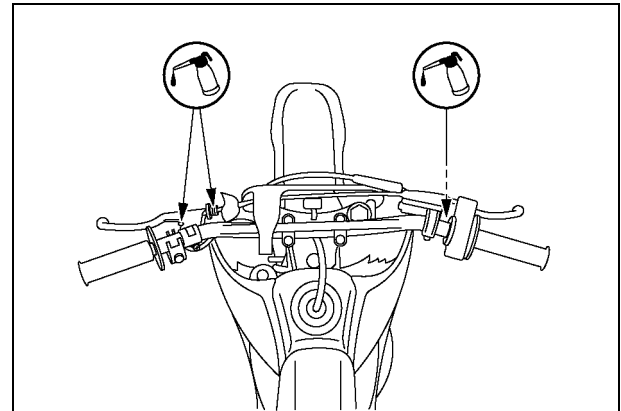

106 MAINTENANCE AND ADJUSTMENT

- Rear brake pedal
- Rear brake rod joints
- Kick pedal

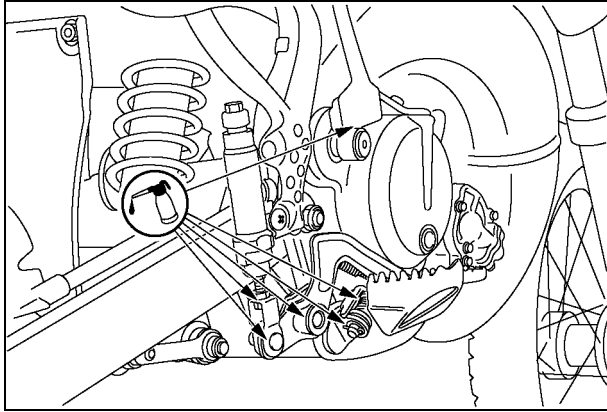

Apply an aerosol cable lubricant with a pressure lubricator on all cables:

- Clutch cable
- Throttle cable

Cable Lubrication

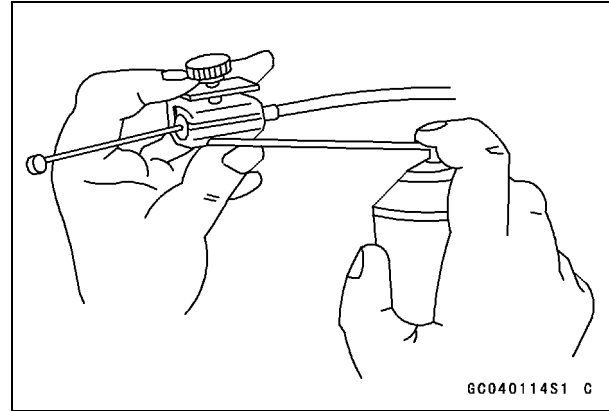

Apply grease to the following points:

- Upper end of clutch cable
- Upper end of throttle cable

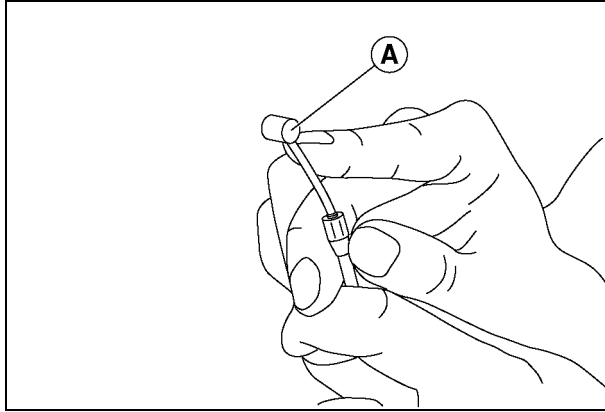

A. Grease.

Drive Chain Lubrication

Lubricate the drive chain after riding through rain or on wet track, or any time that the chain appears dry with a high quality lubricant for drive chains.

- Apply lubricant to the sides of the rollers so that it will penetrate to the rollers and bushings.
- Wipe off any excess lubricant.

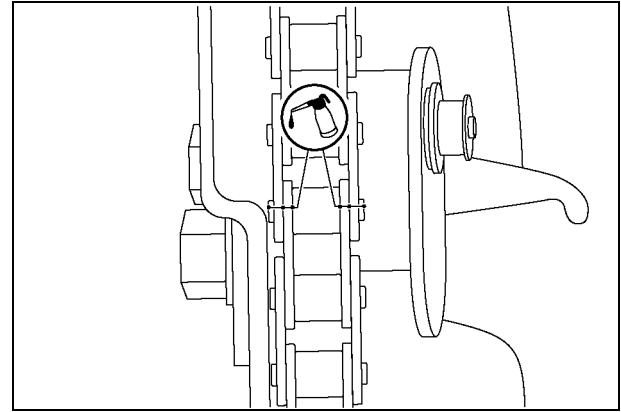

TROUBLESHOOTING GUIDE

NOTE

○ *This troubleshooting guide is not exhaustive and does not give every possible cause for each problem listed. It is meant simply as a quick guide to assist you in troubleshooting for some of the more common difficulties.*

Starting failure or difficulties

Engine does not turn over

- Cylinder or piston seized
- Crankshaft seized
- Connecting rod small end seized
- Connecting rod big end seized
- Transmission gear or bearing seized
- Kick shaft return spring broken
- Kick ratchet gear not engaging

Fuel does not flow

- No fuel in tank
- Fuel tap turned off
- Tank cap air vent obstructed
- Fuel tap clogged
- Fuel line clogged
- Float valve clogged

Engine flooded

- Fuel level too high
- Float valve worn or stuck open

- Wrong starting technique (when the engine is flooded, kick with the throttle fully open to allow more air to reach the engine).

Spark missing or weak

- Spark plug dirty, broken, or gap improperly adjusted
- Spark plug cap or high-tension wiring defective
- Spark plug cap not contacting properly
- Spark plug type incorrect
- Igniter defective
- Ignition coil defective
- Ignition coil resistor defective/disconnected
- Stator damaged
- Wiring shorted or interrupted

Fuel-air mixture incorrect

- Idling adjusting screw improperly adjusted
- Pilot jet or air passage clogged
- Air cleaner element clogged, poorly sealed, or not installed
- Starter jet clogged

Compression low

- Spark plug loose
- Cylinder head insufficiently tightened
- Cylinder nut loose
- Cylinder or piston worn
- Piston ring worn, weak, broken, or sticking
- Piston ring side clearance excessive
- Cylinder head gasket damaged

- Cylinder head warped
- Cylinder gasket damaged
- Reed valve damaged

Poor low-speed performance

Spark weak

- Spark plug dirty, broken, or gap improperly adjusted
- Spark plug cap or high-tension wiring defective
- Spark plug cap shorted or not contacting properly
- Spark plug type incorrect
- Igniter defective
- Ignition coil defective
- Stator damaged

Fuel-air mixture incorrect

- Idling adjusting screw improperly adjusted
- Pilot jet or air passage clogged
- Air cleaner element clogged, poorly sealed, or not installed
- Starter plunger stuck open
- Carburetor fuel level too high or too low
- Fuel tank air vent obstructed
- Carburetor holder loose
- Air intake duct loose

Compression low

- Spark plug loose
- Cylinder head insufficiently tightened
- Cylinder nut loose
- Cylinder or piston worn
- Piston ring worn, weak, broken, or sticking
- Piston ring side clearance excessive
- Cylinder head gasket damaged

- Cylinder head warped
- Cylinder gasket damaged
- Reed valve damaged

Other

- Igniter defective
- Transmission oil viscosity too high
- Brake dragging

Poor or no high-speed performance

Firing incorrect

- Spark plug dirty, damaged, or gap improperly adjusted
- Spark plug cap or high-tension wiring defective
- Spark plug cap shorted or not contacting properly
- Spark plug type incorrect
- Igniter defective
- Ignition coil defective
- Stator damaged

Fuel-air mixture incorrect

- Main jet clogged or wrong size
- Jet needle or needle jet worn
- Jet needle clip in wrong position
- Carburetor fuel level too high or too low
- Air jet or air passage clogged
- Air cleaner element clogged, poorly sealed or not installed
- Starter plunger stuck open
- Fuel supply to carburetor insufficient
- Fuel contaminated with water or foreign matter
- Fuel tank air vent obstructed
- Carburetor holder loose
- Air intake duct loose

110 TROUBLESHOOTING GUIDE

- Fuel tap clogged
- Fuel line clogged

Compression low

- Spark plug loose
- Cylinder head insufficiently tightened
- Cylinder nut loose
- Cylinder or piston worn
- Piston ring worn, weak, broken, or sticking
- Piston ring side clearance excessive
- Cylinder head gasket damaged
- Cylinder head warped
- Cylinder gasket damaged
- Reed valve damaged

Improper acceleration

- Starter plunger stuck open
- Carburetor fuel level too high or too low
- Main jet clogged
- Throttle valve does not fully open
- Air cleaner element clogged
- Muffler clogged
- Fuel contaminated with water or foreign matter
- Cylinder exhaust port clogged
- Brake dragging
- Clutch slipping
- Engine overheating
- Transmission oil level too high
- Transmission oil viscosity too high
- Crankshaft bearing worn or damaged

Knocking

- Carbon built up in combustion chamber
- Fuel quality poor or type incorrect

- Spark plug type incorrect
- Igniter defective

Engine overheating

Firing incorrect

- Spark plug dirty, broken, or gap improperly adjusted
- Spark plug type incorrect
- Igniter defective

Fuel-air mixture incorrect

- Main jet clogged or wrong size
- Carburetor fuel level too low
- Carburetor holder loose
- Air cleaner element clogged, poorly sealed, or not installed
- Air intake duct poorly sealed

Compression high

- Carbon built up in combustion chamber

Engine overloaded

- Brake dragging
- Clutch slipping
- Transmission oil level too high
- Transmission oil viscosity too high

Lubrication inadequate

- Transmission oil level too low
- Transmission oil quality poor or type incorrect

Coolant inadequate

- Coolant level too low
- Coolant deteriorated

Cooling system component defective

- Radiator clogged
- Radiator cap defective
- Water pump not rotating

Clutch operation faulty**Clutch slipping**

- No clutch lever play
- Clutch cable improperly adjusted
- Clutch cable defective
- Clutch plate worn or warped
- Clutch spring broken or weak
- Clutch release mechanism defective
- Clutch hub or housing unevenly worn

Clutch not disengaging properly

- Clutch lever play excessive
- Clutch plate warped or too rough
- Clutch spring tension uneven
- Transmission oil deteriorated
- Transmission oil viscosity too high
- Transmission oil level too high
- Clutch housing frozen on drive shaft
- Clutch release mechanism defective

Gear shifting faulty**Transmission does not go into gear; shift pedal does not return**

- Clutch not disengaging
- Shift fork bent or seized
- Gear stuck on the shaft
- Gear shift positioning lever binding
- Shift return spring weak or broken

- Shift return spring pin loose
- Shift mechanism arm spring broken
- Shift mechanism arm broken
- Shift drum broken

Transmission jumps out of gear

- Shift fork worn
- Gear groove worn
- Gear dogs and/or dog grooves worn
- Shift drum groove worn
- Gear positioning lever spring weak or broken
- Shift fork pin worn
- Drive shaft, output shaft, and/or gear splines worn

Transmission skips gears

- Gear positioning lever spring weak or broken
- Shift mechanism arm spring broken

Engine noise abnormal**Knocking**

- Igniter defective
- Carbon built up in combustion chamber
- Fuel quality poor or type incorrect
- Spark plug type incorrect
- Engine overheating

Piston slap

- Piston clearance excessive
- Cylinder or piston worn
- Connecting rod bent
- Piston pin or piston pin bores worn

Other noise

- Connecting rod small end clearance excessive
- Connecting rod big end clearance excessive

112 TROUBLESHOOTING GUIDE

- Piston ring worn, broken or stuck
- Piston seized or damaged
- Cylinder head gasket leaking
- Exhaust pipe leaking at cylinder head
- Crankshaft runout excessive
- Engine mounts loose
- Crankshaft bearing worn
- Primary gear worn or chipped

Abnormal drive train noise

Clutch noise

- Clutch housing/friction plate clearance excessive
- Clutch housing gear/primary gear backlash excessive
- Metal chip jammed in clutch housing gear teeth

Transmission noise

- Crankcase bearing worn or damaged
- Transmission gear worn or chipped
- Metal chip jammed in gear teeth
- Transmission oil level or viscosity too low
- Kick ratchet gear not properly disengaging from kick gear
- Output shaft idle gear worn or chipped

Drive chain noise

- Drive chain slack improperly adjusted
- Drive chain worn
- Rear and/or engine sprocket(s) worn
- Drive chain insufficiently lubricated
- Rear wheel misaligned

Frame noise abnormal

Front fork noise

- Oil level or viscosity too low
- Spring weak or broken

Rear shock absorber noise

- Shock absorber damaged

Disc brake noise

- Pad installed incorrectly
- Pad surface glazed
- Brake disc warped
- Brake caliper defective
- Brake master cylinder damaged

Other noise

- Bracket, nut, bolt, etc. improperly mounted or tightened

Exhaust smoke

Brownish

- Air cleaner element clogged
- Main jet too large or fallen out
- Starter plunger stuck open
- Carburetor fuel level too high

Poor handling and/or stability

Handlebar hard to turn

- Throttle cable incorrectly routed
- Wiring incorrectly routed
- Steering stem locknut too tight
- Roller bearing damaged
- Steering bearing race dented or worn
- Steering stem inadequately lubricated

- Steering stem bent
- Tire air pressure too low

Handlebar shakes or vibrates excessively

- Tire worn
- Swingarm sleeve or needle bearing damaged
- Rim warped or out of balance
- Front and/or rear axle runout excessive
- Wheel bearing worn
- Handlebar clamp loose
- Steering head nut loose

Handlebar pulls to one side

- Frame bent
- Wheel misaligned
- Swingarm bent or twisted
- Swingarm pivot shaft runout excessive
- Steering maladjusted
- Steering stem bent
- Front fork leg bent
- Right/left front fork oil level uneven

Shock absorption unsatisfactory (suspension too hard)

- Front fork oil excessive
- Front fork oil viscosity too high

- Front fork leg bent
- Tire air pressure too high
- Rear shock absorber improperly adjusted

Shock absorption unsatisfactory (suspension too soft)

- Front fork oil level insufficient and/or front fork leaking oil
- Front fork oil viscosity too low
- Front fork and/or rear shock absorber spring weak
- Rear shock absorber leaking gas
- Rear shock absorber improperly adjusted

Poor braking performance

- Air in the brake line
- Brake pad or disc worn
- Brake fluid leaking
- Brake disc warped
- Brake pads contaminated
- Brake fluid deteriorated
- Primary and/or secondary master cylinder cup(s) damaged
- Master cylinder scratched
- Brake maladjusted (lever or pedal play excessive)

TUNING

Carburetor Tuning

Tuning a carburetor is not the mysterious science many racers believe it to be. One only needs to establish a basic knowledge of the identification and function of carburetor components as well as how they work together to do the job well.

Temperature-and altitude-related mixture adjustment

Condition*	Mixture will be	Adjustment
Cold air	Leaner	Richer
Warm air	Richer	Leaner
Dry air	Leaner	Richer
Low altitude	Standard	None
High altitude (above 1 500 m or 4 900 ft)	Richer	Leaner

*at constant atmospheric pressure and humidity

The main jet size should be increased or decreased by one to five sizes and the engine tested until its power is maximum.

Symptoms of Improper Mixture

If your machine exhibits one or several of the symptoms listed below, it may need carburetor

tuning. Before attempting any changes, however, make sure that everything else is in good shape and properly tuned. Check the condition of the spark plug, make sure the ignition timing is correct, service the air cleaner element and decarbonize the muffler.

If your machine has run properly on a certain track in the past and then starts running poorly with the same carburetor settings, the problem is almost certain to be elsewhere; changing the carburetor settings in such a case would probably be a waste of time.

Symptoms when the mixture is too rich

● Poor acceleration
● Misfire at low engine speeds
● Excessive smoke
● Spark plug fouling
● A “deep” exhaust noise

Symptoms when the mixture is too lean

● Pinging or rattling
● Erratic acceleration
● Same as when running out of fuel
● High engine temperature

With pinging or ratting, make sure that the gasoline is fresh and the octane rattling sufficient. You might also try a different brand of high-octane gasoline.

Making Adjustments

Carburetor tuning is made by replacing or adjusting the main jet, jet needle and pilot jet, which regulate the fuel flow, and the air screw, which regulates the air flow.

The following chart shows the working range of each component. Note how the working ranges overlap as the throttle valve opens.

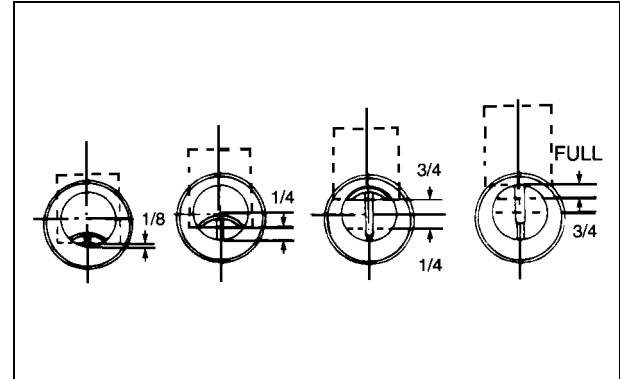
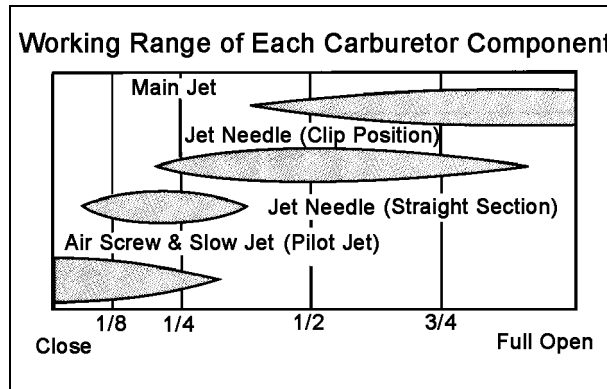

If you note a particular symptom of too rich or lean mixture in a specific operating range, use the chart to determine which components need adjusting. Use the following information to decide what changes to make.

Main Jet

The main jet has its greatest effect in the 1/2-to-full throttle range. The number stamped on the bottom or side of the main jet indicates the size of the hole in the jet which meters fuel. The larger the main jet number, the bigger the hole and the more fuel will flow; hence, larger numbers mean richer jetting; smaller numbers mean leaner jetting. Make main jet changes one size at a time.

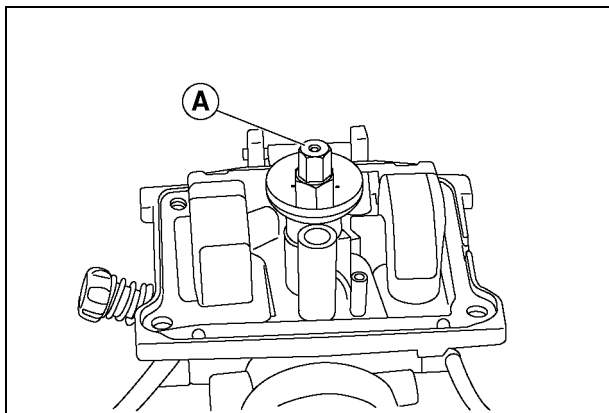

A. Main Jet

WARNING

Gasoline is extremely flammable and can be explosive under certain conditions, creating the potential for serious burns. Do not smoke. Make sure the area is well-ventilated and free from any source of flame or sparks; this includes any appliance with a pilot light.

Jet Needle and Needle Jet

The jet needle and needle jet together have their greatest effect in the 1/4-to-3/4-throttle range. The needle moves in and out of the needle jet. Since the needle is tapered, its position in the needle jet determines the amount of fuel allowed to pass through.

There are five grooves in the top of the jet needle in which a clip fits. This clip positions the jet needle in the throttle valve relative to the needle jet.

Moving the clip down has the effect of pulling the needle further out of the jet; the mixture is thereby enriched. Moving the clip up leans the mixture. Change the clip position one step at a time.

The straight section of the jet needle affects the throttle response at smaller throttle openings.

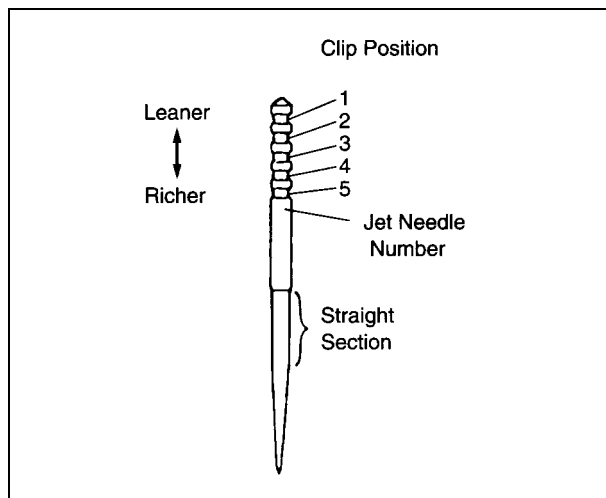

If changing the clip position does not provide the proper setting, the needle jet may be changed. This will make a large difference in the amount of fuel provided.

On the side of the needle jet two figures are stamped: a letter followed by an even number; these figures indicate the relative size of the needle jet. The letter is "N" (leaner) or "O" (richer). The number stands for one of five sizes within each letter's range. The smaller the number is, the leaner the needle jet. Change the needle jet one step at a time, and make fine adjustments with the jet needle clip.

After changing the clip position of the jet needle or replacing the jet needle, check if the throttle valve operates smoothly.

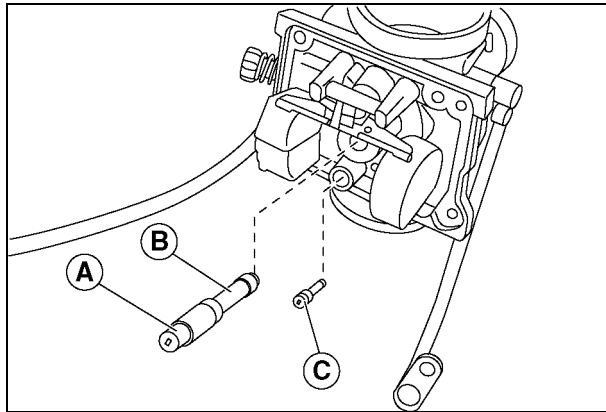

A. Main Jet
B. Needle Jet
C. Pilot Jet

Pilot Jet and Air Screw

The pilot jet and air screw control the mixture in the closed-to-1/8-throttle range, but have little effect between that and full throttle. To adjust the mixture in this range, the air screw can be turned to change the air flow, or the pilot jet can be replaced to change the fuel flow. Start by turning the air screw. Screwing the air screw in enriches the mixture. Air screw specifications indicate the number of turns out from the lightly seated position. Make changes in 1/2-turn increments.

If turning the screw between one and two-and-a-half turns does not provide the desired results, go over to adjusting the pilot jet. The pilot jet has a number stamped on it, which indicates its size; the larger the jet number is, the richer the mixture. Make one-step changes of the slow jet and fine-tune with the air screw.

118 TUNING

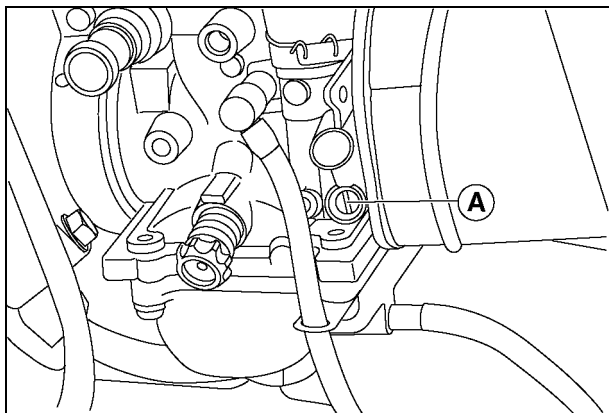

A. Air Screw

Test Runs

- With all carburetor settings on standard, warm up the engine, run two or three laps of the course and examine the spark plug condition with varying throttle openings.

Fuel-Air Mixture Adjustment

Spark Plug Insulator Condition	Mixture
Dry and a light tan color	correct
Whitish	too lean
Wet and sooty	too rich

- If the spark plug insulator is whitish, the fuel-air mixture is too lean. Increase the main jet size by one step.
- If the spark plug insulator is wet, the fuel-air mixture is too rich. Reduce the main jet size by one step.
- Tune the carburetor so that the engine delivers satisfactory power at all throttle openings.

NOTE

- *If the air-fuel mixture is too lean, the engine tends to overheat and may seize up. On the other hand, if the air-fuel mixture is too rich, the spark plug gets wet, which causes misfiring. The richness of the mixture varies depending on atmospheric conditions (pressure, humidity, and temperature). Adjust the carburetor taking these conditions into consideration.*

Altitude and Temperature Correction Factors

NOTE

- *For the following recommendations to be applicable, you must use the standard settings as a base. Do not change any of the settings until you have determined which are necessary. All specifications are based on the use of the specified fuel and oil.*

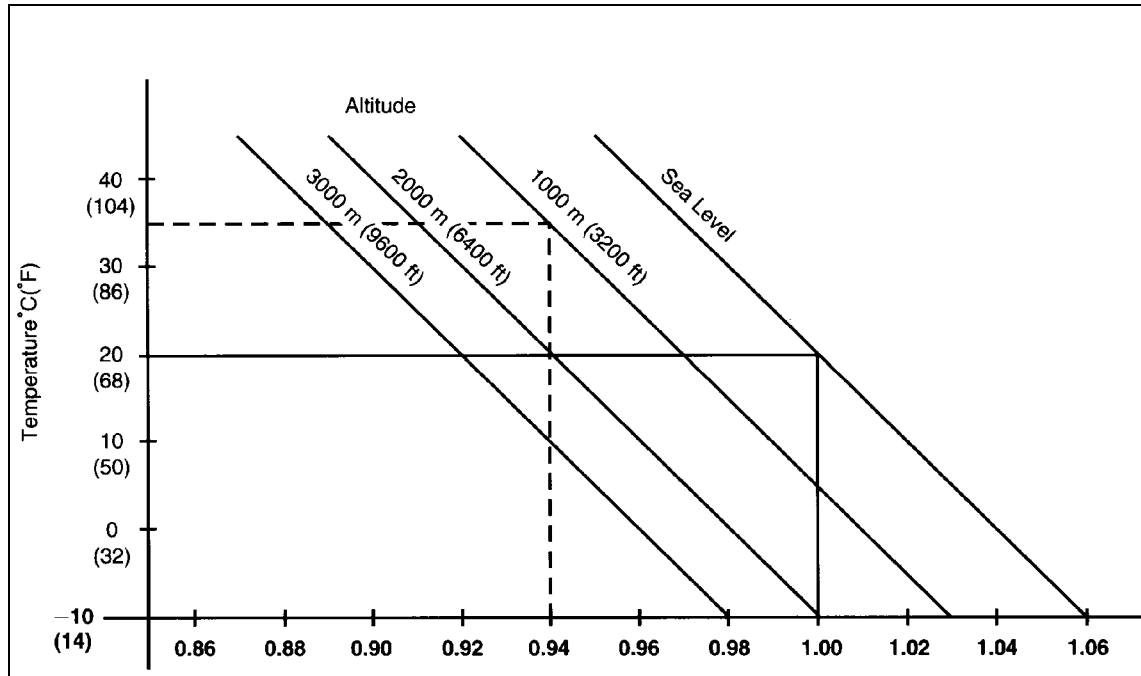

Correction Factor Applied to the Jet Needle and Air Screw

Correction factor	1.06 or above	1.06 ~ 1.02	1.02 ~ 0.98	0.98 ~ 0.94	0.94 or below
Jet needle setting	lower clip one position	same			raise clip one position
Needle jet	two sizes larger	one size larger	same	one size small	two sizes small
Air screw opening	one turn in	1/2 turn in	same	1/2 turn out	one turn out

120 TUNING

Standard Carburetor Settings

Throttle Valve Cutaway	#1.5
Air Screw Opening	1 1/2
Pilot Jet	#25
Needle jet	O-0
Jet Needle	5GSP68-3
Jet Needle Clip Position	3
Main Jet	#190

- Determine the altitude and temperature correction factor.

EXAMPLE: At 1 000 meters (3 200 ft) altitude and an air temperature of 35°C (95°F), the correction factor is 0.94 (see dotted line in the appropriate chart on the previous page).

- Select the correct pilot jet and main jet.

EXAMPLE: For a correction factor of 0.94, multiply the jet size by that number.

Pilot Jet Size Selection for a Correction factor of 0.94

$$\#25 \times 0.94 = \#22.5$$

Main Jet Size Selection for a Correction factor of 0.94

$$\#190 \times 0.94 = \#180$$

- Change the jet needle clip position, needle jet and air screw opening according to the appropriate chart on the previous page.

EXAMPLE: For a correction factor of 0.94, raise the needle clip one position and turn out the air screw one extra turn.

Jet Needle Clip and Air Screw Setting for a Correction Factor of 0.94

Jet Needle Clip	3rd groove from top –1 groove= 2nd groove
Air Screw	1 1/2 turns out +1 turn out = 2 1/2 turns out

Suspension Tuning

Introduction

No area of machine adjustment is more critical than proper suspension tuning. An improperly tuned suspension will keep even the best rider from attaining the full benefit of his machine's ability. Match the suspension to the rider and the course conditions.

WHILE TUNING THE SUSPENSION, KEEP THE FOLLOWING IMPORTANT POINTS IN MIND:

- If the machine is new, "break in" the suspension with at least one hour of riding before making any setting evaluations or changes.
- The three major factors which must be considered in suspension tuning are RIDER WEIGHT, RIDER ABILITY, and TRACK CONDITIONS. Additional influences include the RIDER'S STYLE and POSITIONING on the machine.
- Before changing the suspension settings, test changing your riding posture or position to check whether it is the cause of the problem or not.
- It is a wise practice to adjust the suspension to suit the rider's strong points. If you are fast in the corners, adjust the suspension to allow fast cornering.
- Make setting changes in small increments. A little bit goes a long way, and a setting is easily over-adjusted.

- The front and rear suspension should always be balanced; when the one is changed, the other one might need to be changed similarly.
- When evaluating suspension performance, the rider must make every effort to ride consistently and to recognize the effects of his input. Such things as changes in rider position and increasing fatigue may lead to incorrect judgments about necessary adjustments.
- When the proper settings have been determined for a particular track, they should be written down for reference when returning to the same track.
- Lubricate the bearings in the swingarm and UNI-TRAK® linkage after break-in and after every 5 races to prevent friction from affecting suspension performance.

Front Fork

Front Fork Oil Level

The fork oil level in the fork tube is adjustable. A change in the fork oil level will not affect the spring force much at the top of fork travel, but it will have a great effect at the bottom of it.

- When the oil level is raised, the air spring becomes more progressive, and the front fork action feels "harder" in the later stage of fork travel, near the bottom.
- When the oil level is lowered, the air spring becomes less progressive, and the front fork action does not feel as "hard" in the later stage of fork travel.

122 TUNING

Fork Oil Level Effect on Fork Stroke

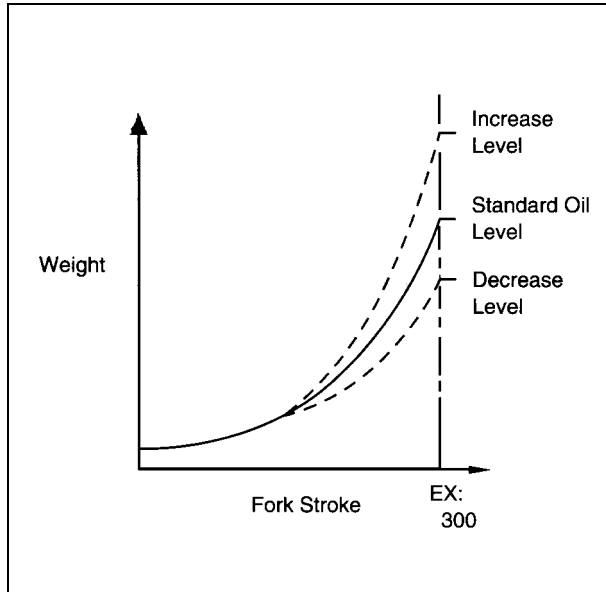

Changing the fork oil level works effectively at the end of fork travel. If fork bottoming is experienced, raise the fork oil level in 10 mm (0.4 in.) increments. This will change the secondary spring rate.

Front Fork Oil Level Adjustment

- Adjust the front fork oil level (see Fork oil level adjustment under Front suspension in the Maintenance and Adjustment chapter).

Troubleshooting Improper Settings

Listed below are some symptoms of improper suspension settings and the most likely means of correcting them. The proper settings can be achieved by applying the information given in this chapter in a scientific, methodical manner. This does not mean, however, that you must be a scientist or trained technician to succeed. Simply take time to think about the changes you believe are necessary, check them against the symptoms and cures described here, make the changes in small increments, and take note of the changes and their effects.

Front Fork Improper Adjustment Symptoms:

Too Hard

Spring too stiff

- Spring too strong
- Oil level too high
- Oil viscosity too low

Suspension stiffens at the end of the fork stroke

- Fork oil level too high

Spring OK, but suspension too hard:

- Oil viscosity too low
- Fork oil deteriorated

Too Soft

The front fork dives excessively during braking and deceleration:

- Fork oil level too low
- Springs too soft
- Oil viscosity too high
- Fork oil deteriorated
- Rebound damping improperly adjusted

Rear shock absorber improper adjustment symptoms

Too Hard

Suspension too stiff

- Spring too hard

Springing OK but suspension too hard

- Unbalance between the spring and the rebound damping (rebound damping too low)
- Spring preload too high (hard)

Too Soft

Bottoming occurs on landing after a high jump (otherwise OK)

- Spring preload too soft
- Spring too soft
- Shock absorber oil deteriorated

Determining the Proper Settings

Standard Settings

From the factory, the machine is set up for a medium-weight rider with intermediate riding ability. Hence, if the actual rider weighs considerably more or less, or if his riding experience and ability are much above or below the intermediate level, it is likely that a few basic suspension adjustments will be necessary.

Basic Readjustment of the Suspension

Suspension Tuning According to Ground Surface

Smooth Terrain	Softer Spring
Rough Terrain	Harder Spring

Suspension Tuning According to Riding Experience

Beginner	Softer Spring with Greater Rebound Damping
Experienced Rider	Harder Spring

Suspension Tuning According to Rider Weight

Heavy Rider	Harder Spring
Light Rider	Softer Spring

124 TUNING

Suspension Tuning According the Type of Course

Many Corners	Lower the front end slightly. [Increase the amount of fork tube protrusion above the upper fork clamp by 5 mm (0.2 in.)]. This accelerates steering and enhances turning ability.
Fast Course	Raise the front end slightly. [Decrease the amount of fork tube protrusion above the upper fork clamp by 5 mm (0.2 in.)]. This slows down steering and enhances stability at high speed.
Deep Dips or Sandy Ground	Raise the front end slightly to gain stability.

Begin the actual on-track testing and evaluation after making these preliminary adjustments.

Bear in mind the following points when readjusting the suspension.

- Always make changes in small steps.
- The rider must be consistent in evaluating suspension performance.
- A change in the front suspension might require one in the rear suspension, and vice versa.

Front and Rear Suspension Compatibility Inspection

Use this procedure to determine if the suspension is balanced reasonably well.

- Hold the motorcycle upright (remove the side stand).
- While standing next to the machine, lightly pull the brake lever, place one foot on the footpeg closest to you, and push down hard. If the motorcycle stays level as the suspension is compressed, the spring rates are well balanced.
- Sit astride the motorcycle, take a riding posture and check that the machine is in a horizontal position. If one end drops noticeably more than the other, the front and rear are not compatible and must be readjusted to achieve a better balance.

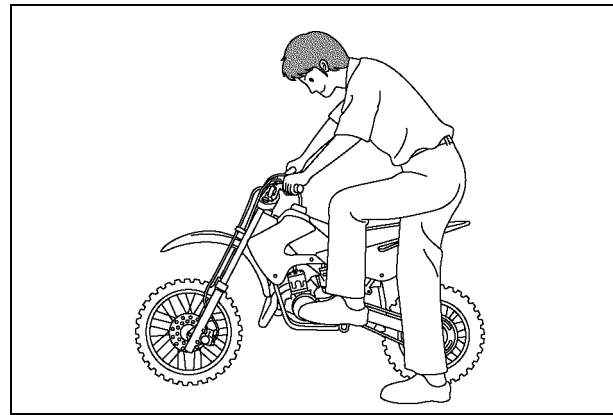

Although this is one of the most effective adjustment procedures, suspension settings may vary depending on the conditions at the track and the rider's preferences.

Front and Rear Suspension Troubleshooting

Front End Surges Downhill or During Acceleration Out of Corner

The front suspension is too soft.

- Increase the fork oil level by 10 mm (0.4 in.).
- Use an optional harder spring.

Front End “Knifes” or Oversteers in Turns (Tends to Turn Inward)

The front suspension is too soft.

- Increase the fork oil level by 10 mm (0.4 in.).
- Increase the rebound damping.

NOTE

○ *Heavier or expert riders may need a harder spring.*

Front End Pushes or “Washes Out” in Turns (Front Wheel Tends to Push Outward Rather than “Bite” in a Turn)

The front suspension is too stiff.

- Decrease the rebound damping.
- Decrease the fork oil level by 10 ~ 15 mm (0.4 ~ 0.6 in.).
- Use a softer spring.

NOTE

○ *Lighter or less experienced riders may need a softer spring.*

Front End Does Not Respond to Small Bumps in Sweeping Turns

The front suspension is too hard.

- Decrease the rebound damping.
- Decrease the fork oil level by 10 ~ 15 mm (0.4 ~ 0.6 in.).
- Use a softer spring.

Rear End “Kicks” When Braking on Bumps

The rear shock absorber rebound damping may be too low.

- Increase the rebound damping.

Rear Tire Does Not “Hook Up” Out of Corners (Lack of Traction Coming Out of Turns)

The rear shock absorber may be too stiff.

- Decrease the rear shock absorber spring preload.
- Use a softer spring (Lightweight Rider Only).

Fork Bottoms Off After a High-speed Jump (may be due to improper riding posture)

The rebound damping is too soft or the spring is too hard.

- Increase the rebound damping.
- Decrease the rear shock absorber spring preload

Front and Rear Ends Bottom Off After a High-speed Jump (harsh bottoming occurs once or twice per lap)

The front suspension is too soft.

- Increase the fork oil level by 10 mm (0.4 in.).
- Use a harder fork spring. The rear suspension is too soft.
- Increase the rear shock absorber spring preload.
- Use a harder spring.

126 TUNING

NOTE

- *Check the front and rear suspension compatibility after making any adjustment.*

Rear End Bottoms at Low Speed

- Increase the spring preload up to maximum.

Rear End Bottoms After 3 or 4 Successive Jumps

- Decrease the rebound damping.

NOTE

- *The rear shock absorber behavior on this machine may mislead some riders.*
- *The rear shock absorber bottoms (due to full stroke) when the spring and damping are overcome by the total weight of the machine and rider.*
- *A bottoming sensation (even though the machine is actually not bottoming) may be caused by machine weight and the inability of the rider to overcome an overly stiff spring or excessive damping.*
- *Observe the rear end jumps and try lowering the spring preload and damping if it does not approach bottoming.*

Gearing

Selection of the Secondary Reduction Ratio (Rear Sprocket)

Rear Sprocket Selection According to Course Conditions

Fast Course	Small Sprocket
Many Curves or Hills	Large Sprocket
Sandy or Soft Ground	

- If the course has long straight portions, the secondary reduction ratio should be reduced so that the machine speed can be increased.
- If then the course has many corners or uphill or is wet, the secondary reduction ratio should be increased so that gear shifting and acceleration are smooth.
- Since the speed must be changed depending on the ground condition on the day of the race, be sure to run through the circuit prior to a race and tune the machine accordingly.
- If there is a long straight portion of the course on which the machine can be run at maximum speed, the machine should be set so that the maximum speed is developed toward the end of the straight course, but care should be taken not to over-rev the engine.

- Since it is difficult to set the machine so it is best suited for all portions of the circuit, determine which circuit portions will have the greatest effect on lap time, and tune the machine to these portions. Confirm your settings by recording lap times after each change. In this way the machine will deliver best performance for the entire circuit.

Special Care According to Track Conditions

- In dry, dusty conditions (such as volcanic ash or fine powdery dust), special care must be given to keeping the air cleaner element clean.
- When riding on wet, heavy clay, mud adheres to the tires and other parts of the vehicle. The mud can add significantly to the weight of the vehicle and therefore reduce performance. Take care to remove built-up mud from the tires and chassis after each ride, before drying occurs.
- The engine works hardest in muddy conditions and the radiator can become clogged with mud. Take care not to overheat the engine in these conditions. The engine also works very hard when riding in deep sand.
- In muddy or sandy conditions, increase chain slack as the chain and sprockets will be packed with mud or sand, which reduces chain slack.
- Check chain and sprocket wear frequently when riding in mud or sand, since wear is increased in these conditions.
- Sticking muds or dusts on the front fork inner tube and rear shock absorber rod could damage to the oil seal, leading to an oil leak. Clean the sticking muds or dusts from the front fork inner tube and rear shock absorber rod after each ride.
- In very dusty conditions, as the air cleaner collects dust, the mixture becomes richer and it may be advisable to apply slightly leaner jetting (main jet).

OPTIONAL PARTS

Carburetor Jets	
Main Jet	170
	180
	200
	210
	230
Pilot Jet	20
	22.5
	27.5
	30
Needle Jet	
Richer	O-4
	O-2
Leaner	N-8
	N-6
Jet Needle	5GSP69

Rear Sprocket
45T
46T
47T (Standard)
48T
49T

Suspension Spring	
Front	K = 0.25 kgf/mm
	K = 0.26 kgf/mm
	K = 0.27 kgf/mm (Standard)
	K = 0.28 kgf/mm
Rear	K = 0.29 kgf/mm
	K = 4.5 kgf/mm
	K = 4.7 kgf/mm
	K = 4.9 kgf/mm (Standard)
	K = 5.1 kgf/mm

Wheel Without Tire	
Front	14 × 1.40
Rear	12 × 1.60

PRE-RACE CHECKS AND AFTER-RACE MAINTENANCE

Pre-race Checks

- Front axle nut, or axle clamp nut tightness
- Front fork clamp bolt tightness
- Handlebar clamp bolt tightness
- Throttle case screw tightness
- Throttle grip operation
- Front and rear brake hose installation
- Front and rear brake fluid level
- Front and rear brake disc and caliper installation
- Front and rear brake function
- Fuel tank installation
- All control cable routings
- Engine mounting bolt torque
- Engine sprocket installation
- Shift pedal bolt torque
- Transmission oil level
- Carburetor clamp screw tightness
- Carburetor top cap tightness
- UNI-TRAK® tie-rod mounting bolt tightness
- UNI-TRAK® rocker arm bolt torque
- Rear shock absorber bolt torque
- Swingarm pivot shaft nut torque
- Rear axle nut torque
- Rear sprocket bolt or nut torque
- Rear brake pedal operation
- Seat installation
- Front and rear wheel spoke tightness

- Front and rear tire air pressure
- Drive chain slack
- Coolant level

Maintenance After the First Race

- Clean the air cleaner element.
- Adjust the drive chain slack.
- Torque the rear sprocket nuts.
- Tighten the spokes.
- Check the front and rear tire air pressure.
- Torque the front and rear axle nuts.
- Torque the swingarm pivot shaft nut.
- Torque the muffler and silencer bolts or nuts.
- Torque the front and rear fender bolts or nuts.
- Torque the fuel tank and seat bolts or nuts.
- Check the front and rear brake function.
- Check the steering play.
- Fill the fuel tank with fuel.
- Check the coolant level.

Maintenance After Riding on a Dusty Course

- If dirt or dust gets into the engine, the crankshaft big end will wear excessively. After riding, inspect the crankshaft big end. If the crankshaft big end is worn past the service limit, replace the crankshaft with a new one.
- Clean the sliding surface of the front fork and rear shock absorber.

130 PRE-RACE CHECKS AND AFTER-RACE MAINTENANCE

Maintenance After Riding in the Rain or on a Muddy Course

- Clean the sliding surface of the front fork and rear shock absorber.
- Apply grease to swingarm and rear suspension pivots.
- Inspect the drive chain and rear sprocket for wear.
- Clean the air cleaner element.
- Check the cylinder and crankshaft big end bearings.
- Grease the throttle grip and throttle cables.

Suggested Spare Parts

- Front and rear wheels
- Shift pedal and brake pedal
- Brake lever, clutch lever, and holders
- Throttle and clutch cables
- Handlebar
- Front and rear fenders, side covers, and number plate
- Radiator, radiator cover, and coolant hoses

- Throttle grip assembly
- Carburetor jets
- Air cleaner element
- Muffler, silencer, and related parts
- Chain cover
- Front springs (for suspension adjustment)
- Rear shock absorber spring (for suspension adjustment)
- Rear sprockets with bolts/nuts and circlips
- Electrical parts
- Spark plugs
- Clutch assembly and friction plates
- Gaskets
- Front and rear tires (various compounds and tread patterns for different conditions)
- Front fork assembly
- Piston and piston rings
- Tire wraps, bolts, nuts, O-rings, washers, snap rings, wire, adhesive tape, vinyl tap (or duct tape), and #400 to #600 emery cloth

STORAGE

Before Storage

When the motorcycle is to be stored for any length of time, it should be prepared for storage as follows.

- Clean the entire vehicle thoroughly.
- Run the engine for about five minutes to warm the oil, then stop it and drain the transmission oil.

WARNING

Engine oil is a toxic substance. Dispose of used oil properly. Contact your local authorities for approved disposal methods or possible recycling.

- Install the oil drain plug and fill in fresh transmission oil.
- Empty the fuel tank and the carburetor float bowl (Fuel will deteriorate if left for a long time).

WARNING

Gasoline is extremely flammable and can be explosive under certain conditions, creating the potential for serious burns. Always stop the engine and never smoke while handling fuel. Make sure the area is well-ventilated and free from any source of flame or sparks; this includes any appliance with a pilot light. Make sure the engine is cold before working. Wipe any fuel off the engine before starting it. Gasoline is a toxic substance. Dispose of gasoline properly. Contact your local authorities for approved disposal methods.

- Remove the spark plug and spray fogging oil, such as Kawasaki K-Kare Fogging oil (part number K61030002), directly into the cylinder. Kick the engine over slowly a few times to coat the cylinder wall. Install the spark plug.
- Lubricate the drive chain and all the cables.
- Spray oil on all unpainted metal surfaces to prevent rusting. Avoid getting oil on rubber parts and on the brakes.
- Lift the motorcycle on a box or stand so that both wheels are raised off the ground (If this cannot be done, put boards under the front and rear wheels to keep dampness away from the tire rubber).
- Tie a plastic bag over the muffler to prevent moisture from entering.

132 STORAGE

- Cover the motorcycle to keep dust and dirt away from it.

After Storage

- Remove the plastic bag from the muffler.
- Make sure the spark plug is tight.
- Fill the fuel tank with fuel.
- Check all the points listed in the Daily pre-ride checks section.
- Perform a General Lubrication Procedure.

ENVIRONMENTAL PROTECTION

Kawasaki subscribes to the guidelines of Tread Lightly! a program dedicated to protecting the great outdoors through education and fostering responsible enjoyment of public lands. When using your Kawasaki Motorcycle, please follow these Tread Lightly! guidelines:

Tread Lightly!

Travel responsibly on designated roads and trails or in permitted areas.

Respect the rights of others including private property owners and all recreational trail users, campers and others to allow them to enjoy their recreational activities undisturbed.

Educate yourself by obtaining travel maps and regulations from public agencies, planning for your trip, taking recreation skills classes, and knowing how to use and operate your equipment safely.

Avoid sensitive areas such as meadows, lakeshores, wetlands and streams, unless on designated routes. This protects wildlife habitat and sensitive soils from damage.

Do your part by leaving the area better than you found it, properly disposing of waste, minimizing the use of fire, avoiding the spread of invasive species, restoring degraded areas, and joining a local enthusiast organization.

Properly discard used batteries, tires, engine oil, other vehicle components, or the entire vehicle that you might dispose of in the future. Consult your authorized Kawasaki dealer or local environmental waste agency for their proper disposal procedure.

WIRING DIAGRAM

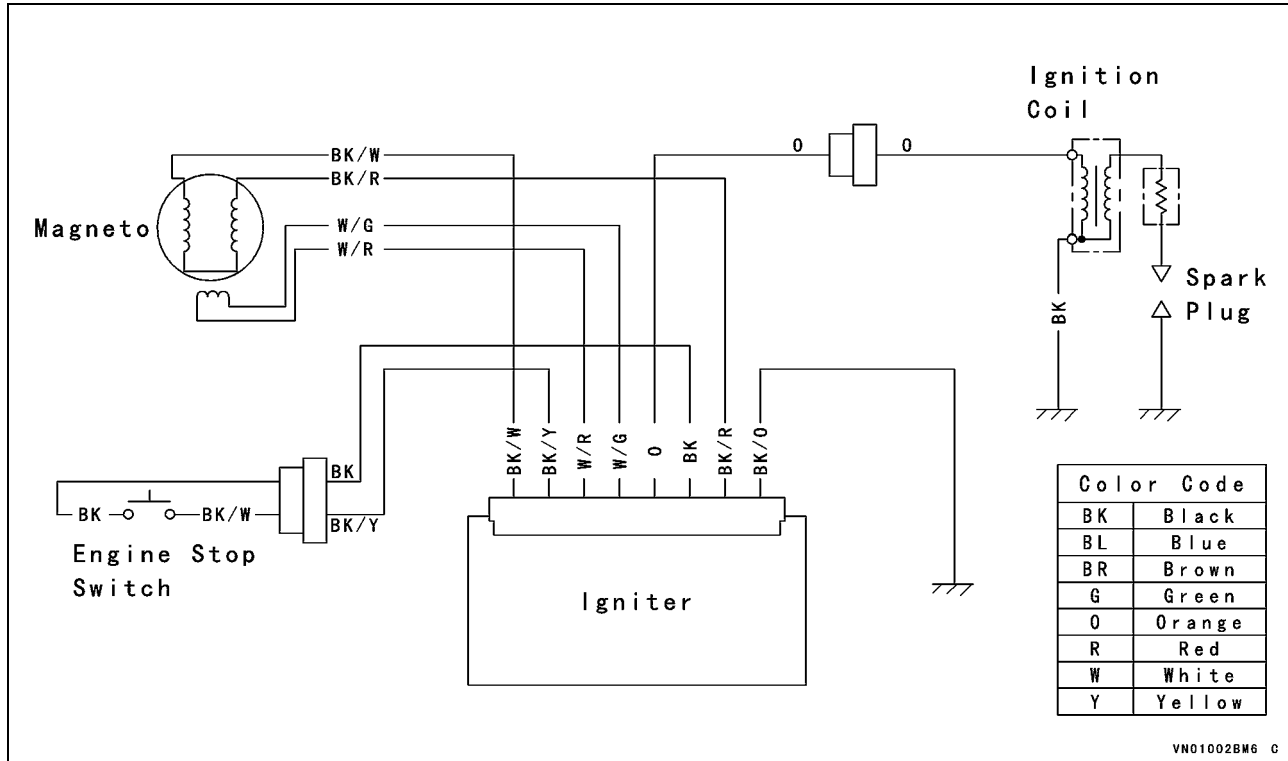

KX65AE



* 9 9 9 8 7 - 1 7 9 1 *



KAWASAKI HEAVY INDUSTRIES, LTD.
Motorcycle & Engine Company

Part No. 99987-1791

Printed in Japan

GB