



RM85/L

OWNER'S SERVICE MANUAL

Part No. 99011-02B82-01A
April, 2006 (TK) EN

This manual should be considered a permanent part of the motorcycle and should remain with the motorcycle when resold or otherwise transferred to a new owner or operator.

The manual contains important safety information and instructions which should be read carefully before operating the motorcycle.

FOREWORD

This manual is presented as a means whereby you can maintain your RM85 in top working condition at all times. Your riding skill and the maintenance steps outlined in this manual will assure you of top performance from your machine under any type of competition.

We sincerely wish you and your Suzuki motorcycle a successful partnership for many years of happy riding.

All information, illustrations, photographs and specifications contained in the manual are based on the latest product information available at the time of publication. Due to improvements or other changes, there may be some discrepancies in this manual. Suzuki reserves the right to make production changes at any time, without notice and without incurring any obligation to make the same or similar changes to vehicles previous built or sold.

Suzuki Motor Corporation believes in conservation and protection of Earth's natural resources. To that end, we encourage every vehicle owner to recycle, trade in, or properly dispose of, as appropriate, used motor oil, engine coolant, and other fluid, and tires.

SUZUKI MOTOR CORPORATION

WARNING/CAUTION/NOTE

Please read this manual and follow its instructions carefully. To emphasize special information, the symbol ▲ and the words WARNING, CAUTION and NOTE carry special meanings. Pay special attention to the messages highlighted by these signal words:

▲ WARNING

Indicates a potential hazard that could result in death or injury.

CAUTION

Indicates a potential hazard that could result in motorcycle damage.

NOTE:

Indicates special information to make maintenance easier or instructions clearer.

GENERAL CONSIDERATIONS

- **Wear a helmet and goggles**

A helmet is the most important piece of gear to wear. Helmets do not reduce essential vision or hearing. Generally, helmets do not cause or intensify injury if you crash. Helmets simply help your skull protect your intelligence, your memory, your personality, and your life.

Your eyesight is equally valuable. Wearing suitable eye protection can help keep your vision unblurred by the wind and help shield your eyes from branches and airborne matter like bugs, dirt, or pebbles kicked up by tires. Wear a helmet and eye protection every time you ride.

- **Wear protective gear**

Wear proper clothing when you ride. Avoid loose clothes or scarves, which could get caught in moving parts. Abrasion injuries can be minimized by wearing protective clothing including gloves, strong boots that fit over the ankle, long pants, and a long sleeve shirt or jackets. Experienced riders often wear a kidney belt and chest or back protector for additional comfort and protection.

- **Inspect your machine before riding**

Before each use, perform an inspection per "PERIODIC MAINTENANCE" section starting on page 2-2.

- **No Passengers**

Suzuki RMs are designed for the rider only.

- **Weight limit**

55 kg (120 lbs)

- **Ride with teammates**

Share the fun of motocross riding. A riding partner can also be great help if one of you gets stranded or injured. Of course, your friends will need their own motorcycles because motocross models are not designed for passengers. If none of your friends rides motocross, ask your Suzuki dealer how to go about joining a club. If your friends do ride, you can all join a club – or start one of your own!

- **Practice on level ground**

Before you begin riding, you should find a good place to practice the skills you need to ride safely. Find a flat, open area with enough space to maneuver. Check with your Suzuki dealer or call police department if you do not know where you can ride.

Review the controls on your motorcycle before riding.

- **Know your limits**

Always ride within the boundaries of your own skills. Knowing these limits and staying within them will help you avoid accidents. Ride only in events appropriate for your experience.

Safely competing on a motorcycle requires that your mental and physical skills are fully part of the experience. You should not attempt to operate a motor vehicle, especially one with two wheels, if you are tired or under the influence of alcohol or other drugs. Alcohol, illegal drugs, and even some prescription and over-the-counter drugs can cause drowsiness, loss of coordination, loss of balance, and loss of good judgement. If you are tired or under the influence of alcohol or other drugs, PLEASE DO NOT RIDE your motorcycle.

- **Conclusion.**

The actions of other riders are unpredictable. Your motorcycle's condition can change. These factors can best be dealt with by giving every ride your full attention.

Circumstances beyond your control could lead to an accident. You need to prepare for the unexpected by wearing a helmet and other protective gear, and practicing safe riding techniques to minimize the damage to you and your machine.

May all of your rides on your new Suzuki be winning rides!

SERIAL NUMBER LOCATION

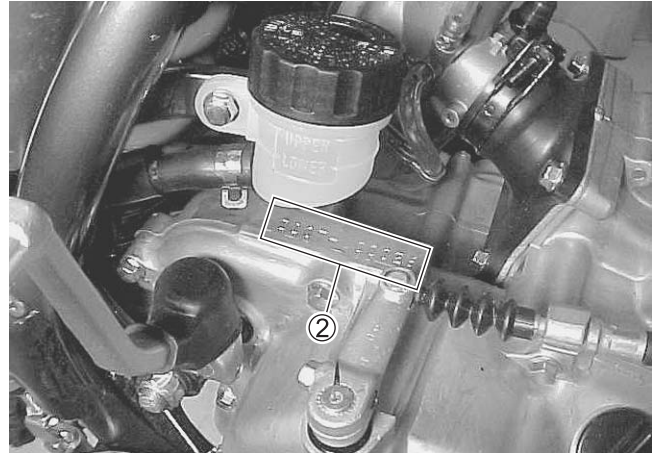

The frame number ① is stamped on the steering head. The engine serial number ② is stamped on the right side of the crankcase assembly.

Write down the serial numbers here for your future reference.

Frame No.	
-----------	--

Engine No.	
------------	--

WARNINGS FOR SERVICING

▲ WARNING

Never run the engine indoors or in a garage. Exhaust gas contains carbon monoxide, a gas that is colorless and odorless and can cause death or severe injury.

Only run the engine outdoors where there is fresh air.

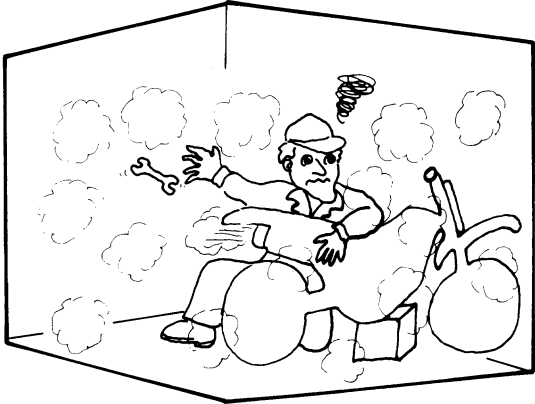

▲ WARNING

Fuel can catch on fire if you do not handle it properly. Gasoline vapors can catch fire easily.

Do not smoke when servicing the machine. Do not service the machine in an area where there are open flames or sparks.

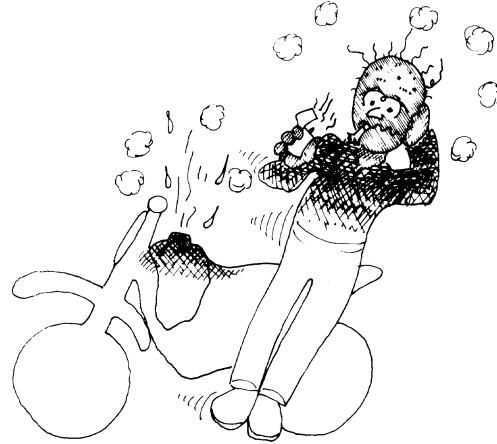

▲ WARNING

Hot engine and muffler can burn you.

Wait until the engine and muffler cools before servicing.



▲ WARNING

Brake fluids and engine coolant can be hazardous to humans and pets. Brake fluid and engine coolant are harmful or fatal if swallowed, and harmful if it comes in contact with your skin or eyes.

Keep brake fluid and engine coolant away from children. Call your doctor immediately if swallowed, and induce vomiting. Flush eyes or skin with water if either brake fluid or engine coolant gets in eyes or comes in contact with skin.



▲ WARNING

Servicing the machine with engine running can be hazardous. You can be caught in the moving parts such as the drive chain, sprockets etc.

Be sure to stop the engine when servicing the machine.



PRECAUTIONS FOR SERVICING

- Replace gaskets, circlips, O-rings and cotter pins with new ones.
- Take care not to expand the end gap larger than required to slip the circlip over the shaft when installing a circlip.
- Use special tools where specified.
- Use genuine SUZUKI parts and recommended oil.
- When two or more persons work together, pay attention to the safety of each other.
- After reassembly, inspect parts for tightness and operation.

▲ WARNING

Servicing the machine without proper clothes and protective gear can be hazardous. You can be injured if you do not wear proper clothes and protective gear.

Be sure to wear proper clothes and shoes for servicing and wear protective glasses, mask or gloves as necessary.











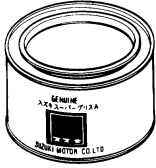

REPLACEMENT PARTS





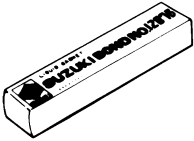

Use only genuine SUZUKI replacement parts or their equivalent. Genuine SUZUKI parts are high quality parts which are designed and built specially for SUZUKI vehicles.

NOTE:

Use of replacement parts which are not equivalent in quality to genuine SUZUKI parts can lead to performance problems and damage.

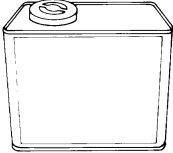
SYMBOL MARKS AND MATERIALS

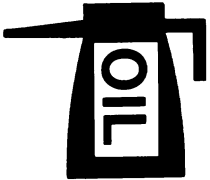
SYMBOL MARK	MATERIALS
	 <p>Apply SUZUKI SUPER GREASE "A" 99000-25010</p>
	 <p>Apply SUZUKI SILICONE GREASE 99000-25100</p>
	 <p>Apply THREAD LOCK SUPER "1303" 99000-32030</p>
	 <p>Apply THREAD LOCK SUPER "1322" 99000-32110</p>
	 <p>Apply SUZUKI BOND "1207B" 99000-31140</p>
	 <p>Use or apply DOT 4 Brake fluid.</p>

SYMBOL MARK	MATERIALS
	 <p data-bbox="873 409 1258 472">Use SUZUKI FORK OIL SS-05 99000-99001-SS5</p>
	 <p data-bbox="873 695 1451 758">Use SUZUKI REAR SUSPENSION OIL SS-25 99000-99001-S25</p>
	<p data-bbox="873 989 1122 1087">Use engine coolant. SUZUKI COOLANT 99000-99032-11X</p>
	<p data-bbox="873 1314 1312 1346">Apply engine oil or transmission oil.</p>
	<p data-bbox="873 1566 1414 1598">Tighten a nut or bolt to the specified torque.</p>
	<p data-bbox="873 1818 1328 1881">Replace a part with a new one when reassembling.</p>

- MEMO -

GROUP INDEX

GENERAL INSTRUCTIONS	1
PERIODIC MAINTENANCE	2
TROUBLESHOOTING	3
MACHINE TUNING	4
ENGINE REMOVAL AND INSTALLATION	5
CYLINDER, PISTON AND EXHAUST VALVE	6
CLUTCH	7
KICK STARTER	8
GEARSHIFTING	9
TRANSMISSION AND CRANKSHAFT	10
FUEL SYSTEM	11
COOLING SYSTEM	12
ELECTRICAL SYSTEM	13
FRONT AND REAR WHEELS	14
FRONT AND REAR BRAKES	15
FRONT FORK AND STEERING	16
REAR SUSPENSION	17
SERVICING INFORMATION	18

GENERAL INSTRUCTIONS

1

CONTENTS

LOCATION OF PARTS	1- 2
FUEL AND OIL RECOMMENDATION	1- 3
INSTRUCTING YOUNG RIDER	1- 4
THIS IS IMPORTANT ADVICE TO A PARENT	1- 4
STARTING ENGINE	1- 5
STARTING OFF	1- 7
BRAKING	1- 7
STOPPING ENGINE	1- 8
BREAK-IN (RUNNING-IN)	1- 8

LOCATION OF PARTS

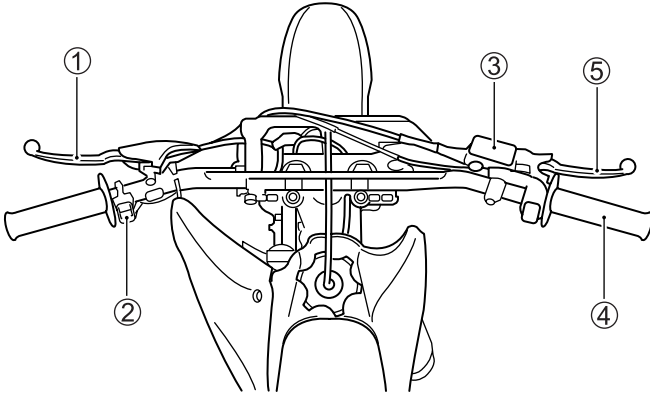

- ① Clutch lever
- ② Engine stop switch
- ③ Front brake fluid reservoir
- ④ Throttle grip
- ⑤ Front brake lever

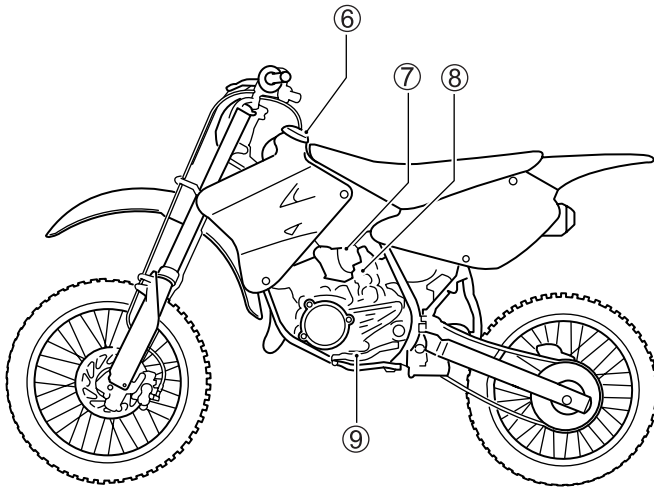

- ⑥ Fuel tank cap
- ⑦ Fuel valve
- ⑧ Carburetor starter knob
- ⑨ Gearshift lever

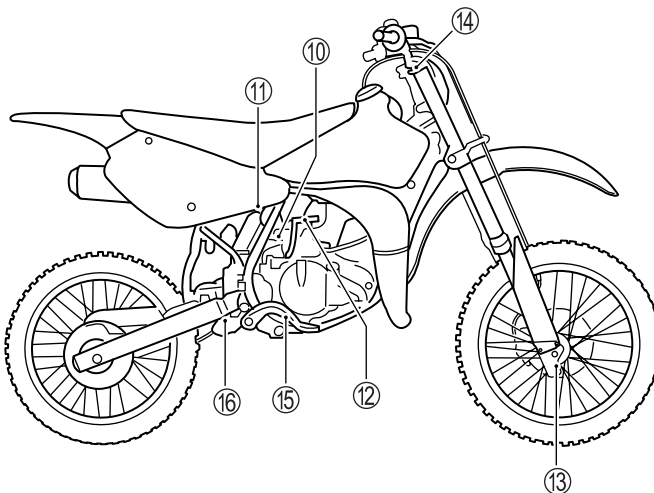

- ⑩ Rear brake fluid reservoir
- ⑪ Rear suspension compression damping adjuster
- ⑫ Kick starter lever
- ⑬ Front suspension compression damping adjuster
- ⑭ Front suspension rebound damping adjuster
- ⑮ Rear brake pedal
- ⑯ Rear suspension rebound damping adjuster

FUEL AND OIL RECOMMENDATION

This motorcycle is of the two-stroke design, which requires a premixture of gasoline and oil.

Gasoline: Use only unleaded gasoline of at least 90 pump octane (R/2 + M/2 method). For Canada
 Use only unleaded gasoline of at least 95 octane. (Research method) For other countries.

Engine oil: MOTUL 800 2T
 or equivalent Two Cycle Racing Lubricant

Mixing ratio: 30 : 1

Fuel tank capacity: 5.0 L (1.3/1.1 US/Imp gal)

Gasoline (L)	Oil (ml)
5.0	166
10.0	333
15.0	500
20.0	666

Gasoline (gal.)	Oil (oz)
1.0	5.4
2.0	10.7
3.0	16.0
4.0	21.4

CAUTION

A mixture containing too little oil will cause piston seizure. Too much oil will cause excessive carbon formation resulting in preignition, fouled spark plug and loss of engine power.

Mix fuel and the engine oil at the ratio of 30:1.

NOTE:

- * Mix gasoline and the engine oil thoroughly when the temperature is below 0 °C (32 °F). Vegetable-based oils can separate easier than mineral oils.
- * Use premixture oil as soon as possible after mixing, or lubrication performance of the engine oil can decrease.
- * Do not mix vegetable-based oil and mineral oil.
- * Insert the end of the breather hose into the steering stem head after refueling.

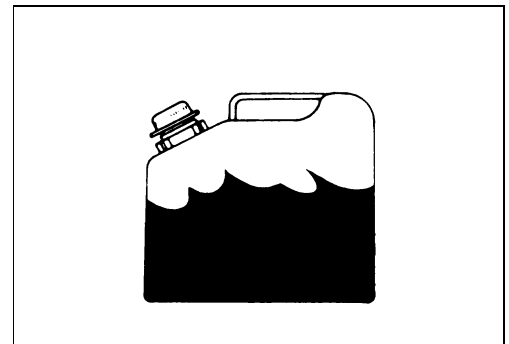

INSTRUCTING YOUNG RIDER

THIS IS IMPORTANT ADVICE TO A PARENT

Children are important; the sight of a new motorcycle excites their imagination; and the expectation is often so great as to make them forget the importance of safety precautions. Please go through this manual with a boy or a girl, page by page, and help him or her to understand not only the mechanism but also the rules of courtesy and safety precaution. The RM85 requires the parent's cooperation to actually enjoy the safety available. Here are six rules in two groups. Please impress upon the mind of the young rider before leaving the machine to his or her disposal:

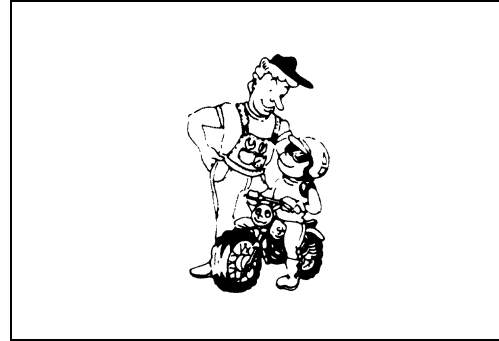

OPERATING SKILL

Rule 1. Know the mechanism

Memorize the name of each control. The name suggests its function. Know the route of drive from engine to wheels.

Learn the order in checking written items for INSPECTION BEFORE RIDING. It is highly recommended that the parent shows examples by demonstrating.

NOTE:

Check to be sure that young rider has perfectly learned. Let your child demonstrate for you.

Rule 2. Rehearse before riding out for the first time

Let the young rider mount the machine and do try rehearsal. Watch the way he or she operates the controls (particularly throttle and brake). Make sure the gearshift pattern and shifting sequence are perfectly memorized, Smooth simultaneous braking (front and rear) is particularly important.

Rule 3. Learn the technique of standing-start and stopping with brakes

Practice makes perfect. Let the young rider repeat following you, many times until you are sure he or she has learned the knack and technique thoroughly.

NOTE:

For practice, choose a level ground free of traffic and spacious enough to permit driving several yards with the engine powered. In short, break-in the young rider gradually.

CLOTHING

Rule 4. Wear simple clothes

Loose fitting clothes are unsafe for riding. Loose belts and scarves, loose trimming etc. can be dangerous.

Rule 5. Avoid scanty clothes

Do not ride wearing short pants or short-sleeve shirt. A large part of riding fatigue comes from loss of body heat due to wind. Abrasive injuries can be avoided by protection clothing.

Rule 6. Avoid stiff clothes

Make sure that knee and elbow actions are free, and that torso bending is not interfered with. Free body movements are essential for safe riding.

NOTE:

The helmet, gloves, boots, goggles and jacket are essential items of clothing.

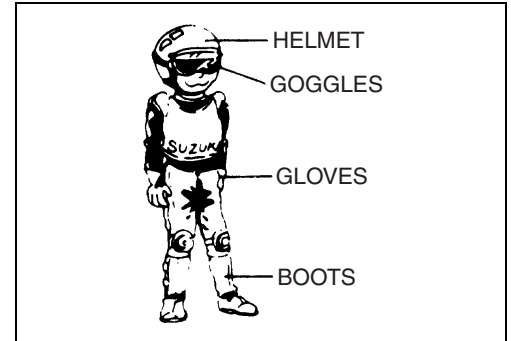
**STARTING ENGINE****STARTING COLD ENGINE**

- Turn the fuel valve lever from OFF to ON.

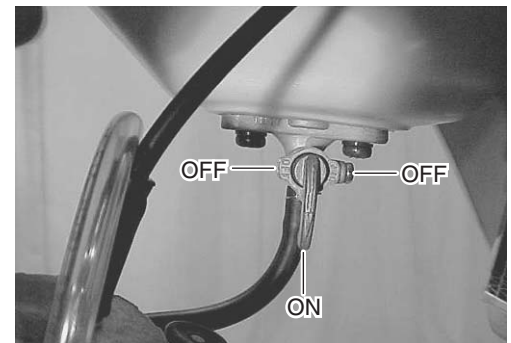

- Jerk the machine back and forth and be sure the gear is in neutral. The machine will resist the jerking if the gear is not in neutral.

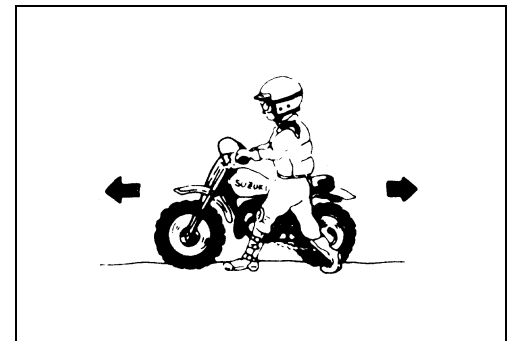

- Pull the starter knob out.



- Close the throttle. Kick the kick starter lever to start the engine. If the engine fails to fire up, kick again. If third or fourth attempt fails, then push back starter knob to original position, and open the throttle wider by turning the throttle grip fully. Then kick the kick starter lever again. As this motorcycle has a primary kick start system, the engine can be started with the transmission in any gear position, only if the clutch is disengaged by squeezing the clutch lever.

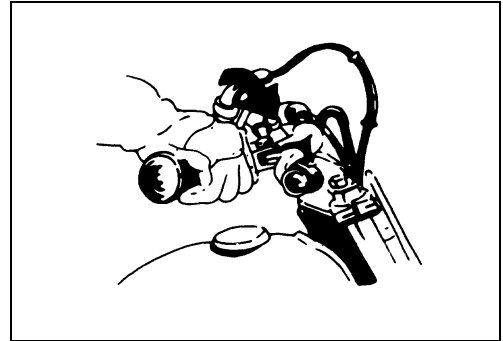

- Upon starting the engine, run it for 30 to 60 seconds to stabilize its speed.
- Push the starter knob back to original position.

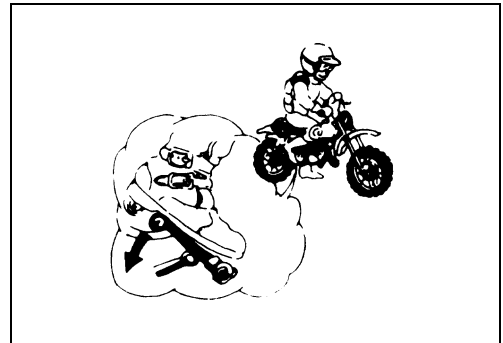

STARTING WARM ENGINE

- Shift the transmission into neutral.
- Open the throttle partially ($1/8 - 1/4$).

NOTE:

Operation of the starter knob is not necessary to start the warm engine.



- Kick the kick starter lever.

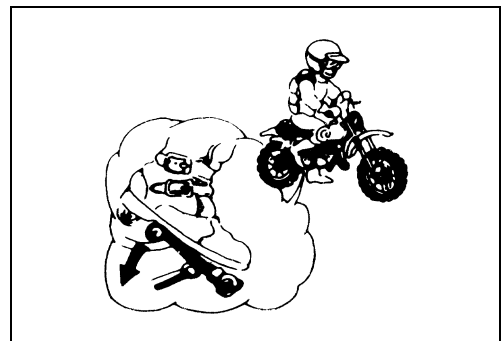

STARTING OFF

- Pull in the clutch lever fully and push the gearshift lever down to change the gear from neutral to low position.

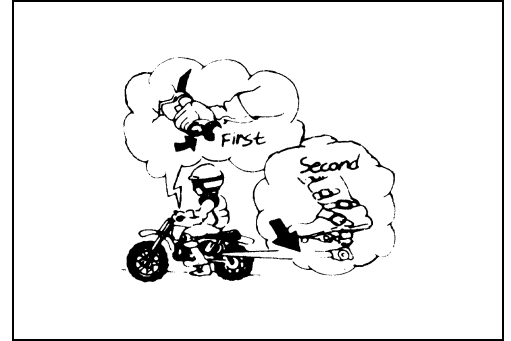

- Release the clutch lever gently while twisting the throttle grip slowly.

⚠ WARNING

Twisting the throttle grip fully in standing start can jump the machine and it can throw you off the seat.

Twist the throttle grip gradually when starting off.

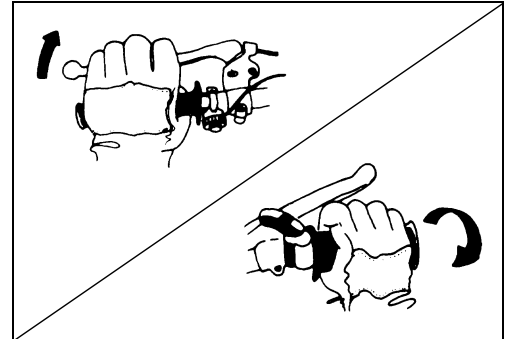

- Pick up speed just a little on low. Twist throttle grip forward and pull in clutch lever; kick up gearshift lever while twisting back the throttle grip. Now pick up speed on second. Repeat this sequence to shift upward step by through third, fourth and fifth to top.

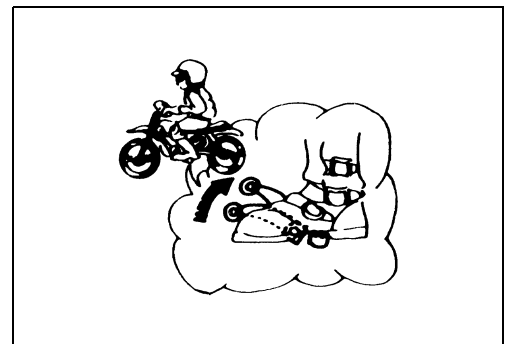

BRAKING

- To slow down, (1) twist throttle grip forward, and (2) brake front and rear wheels. Just before you come to a stop, pull-in clutch lever and shift down into NEUTRAL.



- An attempt to slow down by braking alone is dangerous, particularly braking of the front wheel alone. The front wheel may slide out (front wheel braking) or rear wheel might skid side-wise (rear wheel braking).

⚠ WARNING

Braking when making a turn can lose balance and control.

Brake only when riding straight.

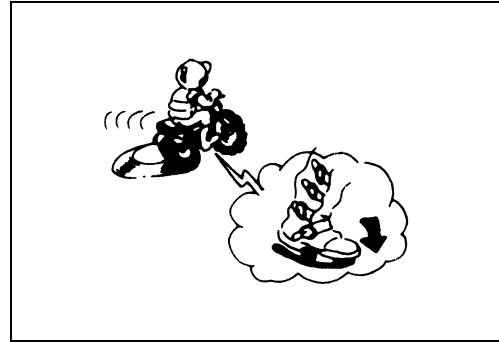
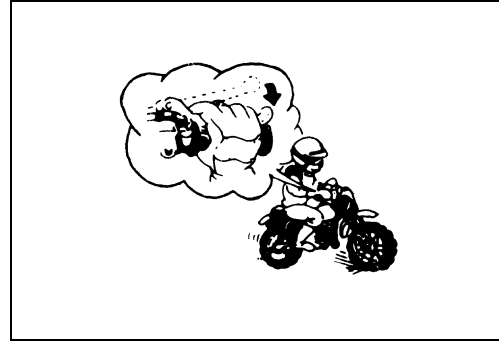

STOPPING ENGINE

- Twist the throttle grip forward.
- Pull in the clutch lever and shift into neutral.
- Hold in engine stop switch until the engine stops.
- Turn the fuel valve lever from ON to OFF.

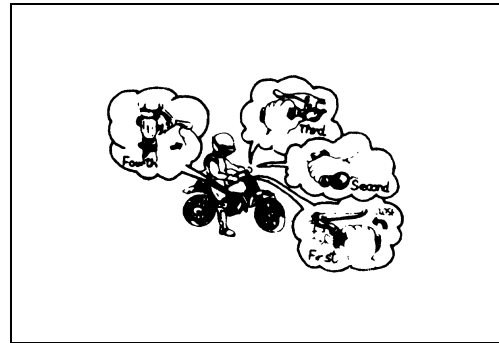

**BREAK-IN (RUNNING-IN)
WHEN THE MOTORCYCLE IS NEW**

1. Warm up the engine before starting off.
 2. Ride for 1 hour using less than 1/2 throttle opening with various throttle opening.
 3. Ride for 1 hour using less than 3/4 throttle opening with various throttle opening.
- The break-in (running-in) period is the period of greatest wear.
 - The bolts and nuts of the new machine can loosen quickly. Be sure to retighten the bolts and nuts during the break-in (running-in) period.

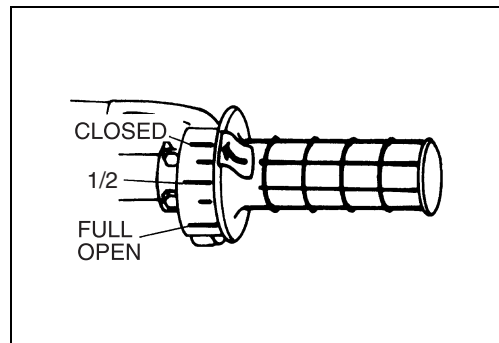

WHEN ENGINE PARTS ARE REPLACED

Follow the same procedure when any of the following parts are replaced:

- | | |
|-------------|--------------------|
| Piston | Crankshaft |
| Piston ring | Crankshaft bearing |
| Cylinder | |

PERIODIC MAINTENANCE

CONTENTS

PERIODIC MAINTENANCE	2- 2
SPARK PLUG	2- 4
AIR CLEANER	2- 5
TRANSMISSION OIL	2- 6
ENGINE COOLANT	2- 8
CLUTCH CABLE	2- 9
THROTTLE CABLE	2-10
FUEL HOSE	2-10
FUEL VALVE	2-11
CYLINDER HEAD, CYLINDER AND PISTON	2-12
EXHAUST VALVE	2-12
EXHAUST SILENCER	2-13
DRIVE CHAIN AND SPROCKETS	2-13
DRIVE CHAIN GUIDE, BUFFER, TENSIONER ROLLER	2-15
BRAKES	2-16
FRONT FORK	2-17
REAR SUSPENSION	2-18
WHEELS AND TIRES	2-18
STEERING	2-19
LUBRICATION	2-20
TIGHTENING TORQUE	2-21

PERIODIC MAINTENANCE INSPECTION BEFORE PRACTICE

WHAT TO CHECK	CHECK FOR
Spark plug	<ul style="list-style-type: none"> • Heat range, fouled electrode, tightness • Loose high-tension cord
Air cleaner element	Lubrication
Transmission oil	Oil level
Engine coolant	Engine coolant level
Cooling system	<ul style="list-style-type: none"> • Radiator hose damage • Engine coolant leak
Clutch	<ul style="list-style-type: none"> • Play • Smooth operation
Throttle	<ul style="list-style-type: none"> • Play • Smooth operation
Brake fluid	Fluid level
Brakes	<ul style="list-style-type: none"> • Brake lever position brake pedal height • Brake lever/pedal play • Operation
Drive chain	Slack, lubrication, chain joint clip condition
Drive chain guide/buffer	Wear, damage
Suspension	<ul style="list-style-type: none"> • Smooth operation • Front fork air pressure
Wheels	<ul style="list-style-type: none"> • Spoke tension • Rim lock tightness
Tires	Tire pressure
Steering	Smoothness, play
Exhaust pipe	Firm fixation
Bolts and nuts	Tightening torque

INSPECTION BEFORE RACE

WHAT TO CHECK	CHECK FOR
All items of inspection before practice above plus.	
Air cleaner	Cleanliness
Clutch	Clutch disc plates wear and distortion
Brake pads	Wear
Sprockets	Wear
Fuel tank	<ul style="list-style-type: none"> • Leakage • Fuel filter clogging
Fuel hose	Damage
Exhaust pipe	Damage
Piston and Cylinder	<ul style="list-style-type: none"> • Combustion chamber carbon deposit • Piston head carbon deposit • Piston and cylinder wear
Front fork	<ul style="list-style-type: none"> • Smooth operation • Front fork air pressure

PERIODIC MAINTENANCE CHART

It is very important to inspect and maintain the machine regularly. Follow the guideline in the chart. The life of parts varies depending on the riding conditions. Perform more often than shown in the chart if you use the motorcycle under severe conditions.

Service Item	Interval	Every race	Every 3 races	Every 9 races	Remarks
	hours	Every 2 hours	Every 6 hours	Every 18 hours	
Spark plug		I	R	—	
Air cleaner		C	—	—	Replace air cleaner element as necessary.
Transmission oil		—	R	—	Change after 1st initial break-in.
Cooling-system		I	—	—	Replace radiator hose and engine coolant every year. Flushing for overhaul or storage.
Clutch		I	—	—	Replace clutch plates as necessary.
Throttle cable and clutch cable		I & L	—	—	
Carburetor		I	—	—	
Fuel hose		I	—	—	Replace every 4 years.
Piston		—	—	R	
Piston ring		—	R	—	
Cylinder head, cylinder		—	C	—	
Exhaust valve		—	C	—	
Muffler		I	—	—	
Drive chain		I & L	R	—	Adjust slack every 30 minutes.
Engine sprocket		I	—	—	
Rear sprocket		I	—	—	Check and retighten sprocket bolts at initial and subsequent 10 minutes of riding and each race thereafter.
Drive chain buffer		—	R	—	
Drive chain guide		—	R	—	
Kick starter lever		I & L	—	—	
Brake		I	—	—	Replace brake hose and fluid every year.
Front fork oil		—	R	—	Change after 1st initial break-in.
Front fork		I	—	—	Check front fork inner tube frequently for abnormality. Check the air pressure.
Rear suspension system pivoting portion		I	—	—	Check rear suspension system frequently and apply the grease to the pivoting portion as necessary.
Tire		I	—	—	
Spoke nipple		I	—	—	Inspect every 20 min. up to initial 2 hours then check before each ride.
Steering		I	—	—	
Bolts and nuts		T	—	—	Retighten every 1 hour.

NOTE: R = Replace, C = Clean, T = Tighten, I = Inspect and clean, adjust lubricate or replace if necessary, L = Lubricate.

SPARK PLUG

- Inspect the spark plug condition, electrode color, carbon deposits, spark plug gap, and washer damage, after removing the spark plug.

NOTE:

Remove the dirt around the spark plug before removing the spark plug to prevent dirt from entering the combustion chamber.

- Inspect the porcelain tip color.

Porcelain tip color	Cause
White (overheated)	<ul style="list-style-type: none"> • Hot type spark plug • Advanced ignition timing • Lean air/fuel mixture • Deteriorated fuel
Black (fouled)	<ul style="list-style-type: none"> • Cold type spark plug • Retarded ignition timing • Rich air/fuel mixture • Rich oil/gasoline mixture

- Check the spark plug gap with a thickness gauge.

DATA Spark plug gap: 0.7 – 0.8 mm (0.028 – 0.031 in)

DATA Standard Spark plug

NGK	BR10ES
-----	--------

CAUTION

Changing the spark plug heat range improperly can damage the engine.

Select the spark plug heat range only after adjusting the ignition timing, carburetor setting and oil/gasoline mixture.

- Tighten the spark plug with specified tightening torque after tightening the spark plug temporarily with fingers.

🔧 Spark plug: 28 N·m (2.8 kgf·m, 20.5 lb·ft)

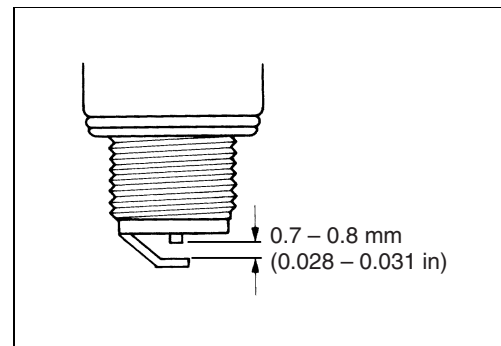

AIR CLEANER

AIR CLEANER ELEMENT REMOVAL

- Remove the seat.
- Remove the air cleaner cap ①.

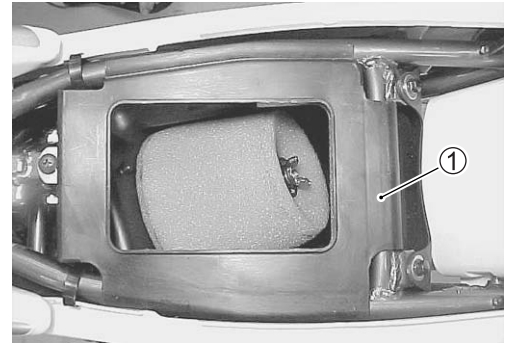

- Remove the wing nut ②.
- Remove the element from the element holder.

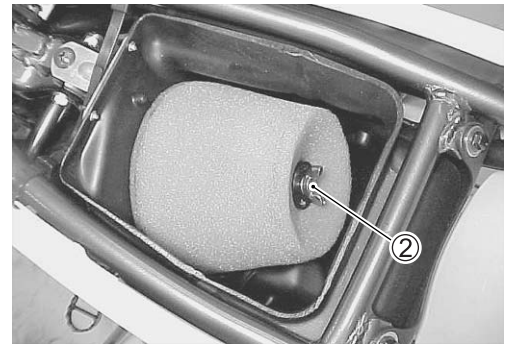

WASHING

- Fill a washing pan large enough to hold the element with a non-flammable cleaning solvent ①. Immerse the element in the solvent and wash it.

①: MOTUL AIR FILTER CLEAN or equivalent cleaning solvent

- Squeeze the element by grasping it to remove excess solvent. Do not twist or wring the element or it will develop cracks.
- Dry the element in a plastic bag, pour in some foam filter oil ② and work the oil into the element.

②: MOTUL AIR FILTER OIL or equivalent filter oil

- Squeeze the element to remove excess oil.

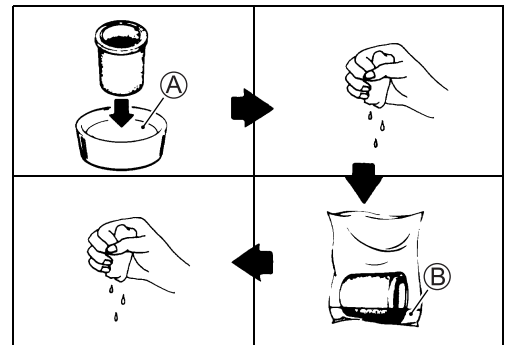

INSTALLATION

- Apply grease to the element base where it contacts the air cleaner box.
- Fit the element onto the element holder.

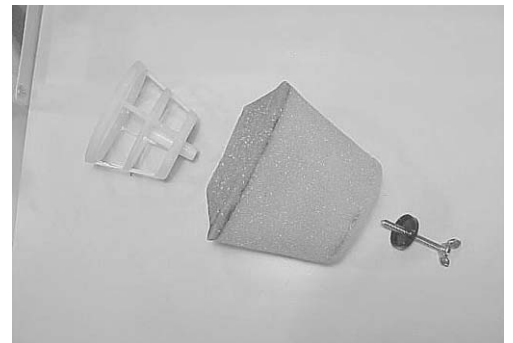

- Install the element in the air cleaner box.

CAUTION

Improper element installation allows dust and dirt to enter the combustion chamber. It can result in piston and cylinder wear.

Be sure to check the element seals properly after installing the elements.

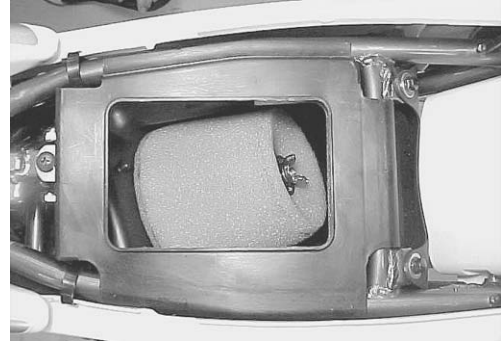

- Install the air cleaner cap.

NOTE:

Running the engine without the air cleaner cap can vary the carburetion. Do not run the engine without the air cleaner cap.

NOTE:

Follow the instructions below to keep the air cleaner element dry when cleaning the motorcycle.

- Cover the element with vinyl bag.
- Install the seat.
- Do not spray high pressure water to the air cleaner box.

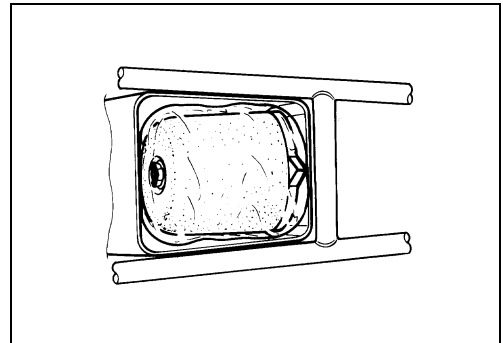

TRANSMISSION OIL

▲ WARNING

Transmission oil and exhaust pipes can be hot enough to burn you.

Wait until the oil drain plug and exhaust pipes are cool enough to touch with bare hands before draining oil.

▲ WARNING

New and used oil and solvent can be hazardous. Children and pets may be harmed by swallowing new or used oil or solvent. Repeated, prolonged contact with used engine oil may cause skin cancer. Brief contact with used oil or solvent may irritate skin.

- * **Keep new and used oil and solvent away from children and pets.**
- * **Wear a long-sleeve shirt and waterproof gloves.**
- * **Wash with soap if oil or solvent contacts your skin.**

NOTE:

Recycle or properly dispose of used oil and solvent.

TRANSMISSION OIL LEVEL INSPECTION AND REPLENISHMENT

- Run the engine for a few minutes and stop it. Wait 5 minutes.
- Place the motorcycle on level ground and hold the motorcycle vertically.
- Remove the oil level screw ①. Check that oil comes out of the hole.
- If oil does not come out of the hole, open oil filler cap ② and add the specified oil. Tighten the filler cap and oil level screw firmly and inspect again as above procedure.
- Tighten the filler cap and oil level screw firmly.

 **Oil level screw: 5.5 N·m (0.55 kgf-m, 4.0 lb-ft)**

TRANSMISSION OIL CHANGE

- Warm up the engine.
- Place the motorcycle on the level ground and hold the motorcycle vertically.
- Remove filler cap ① and drain plug ②. Drain oil thoroughly.
- Tighten the drain plug firmly.

 **Oil drain plug: 23 N·m (2.3 kgf-m, 16.5 lb-ft)**

- Pour specified amount of motor oil.

DATA Oil change550 ml (1.2/1.0 US/Imp qt)
Transmission oil type: SAE 10W-40, API SF/SG or SH/SJ with JASO MA

- Tighten the filler cap.
- Run the engine for a few minutes and stop it. Wait a few minutes.
- Inspect the oil level. (☞ 2-7)

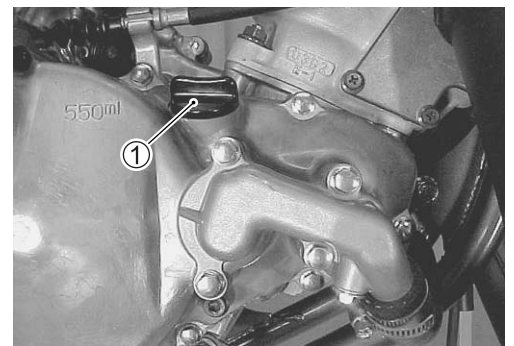
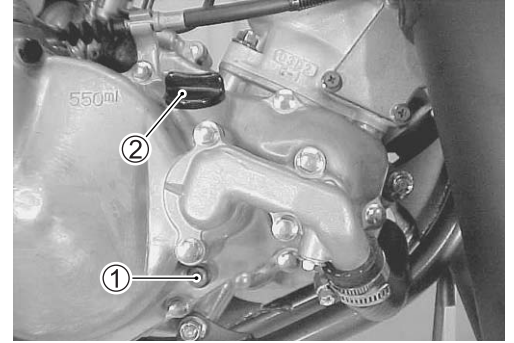

ENGINE COOLANT

ENGINE COOLANT LEVEL CHECK

▲ WARNING

You can be injured by scalding fluid or steam if you open the radiator cap when the engine is hot.

Do not open the radiator cap when the engine is hot.
Wait until engine cools.

- Remove the radiator cap ①.
- Check that the engine coolant level is at the bottom of the inlet hole. If not, replenish the radiator with specified engine coolant.
- Tighten the radiator cap securely.

CAUTION

Improperly tightening the radiator cap will prevent the cooling system from reaching the specified operating pressure and will cause coolant overflow.

Tighten the radiator cap until it locks firmly.

NOTE:

- * This motorcycle does not have an overflow tank at the end of breather hose. Therefore, engine coolant level may decrease while riding. Check the engine coolant level every time before riding.
- * When replenishing engine coolant, be sure to use engine coolant mixed with distilled water at the ratio of 50 : 50. Adding only water will dilute engine coolant and it may decrease cooling performance.
- * If the motorcycle is to be exposed to temperatures below -31°C (-24°F), the percentage of antifreeze should be increased to 55% or 60%, according to figure 1.

Antifreeze density	Freezing point
50%	-31°C (-24°F)
55%	-40°C (-40°F)
60%	-55°C (-67°F)

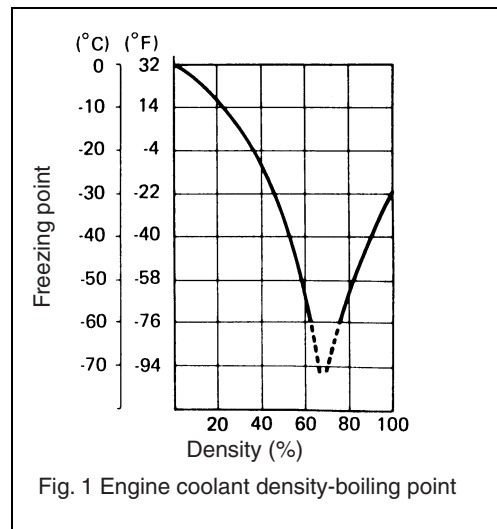

ENGINE COOLANT REPLENISHMENT

- Drain engine coolant. (☞ 12-3)
- Pour engine coolant. (☞ 12-3)
- Use an anti-freeze and Summer engine coolant which is compatible with aluminum radiator, mixed with distilled water at the ratio of 50 : 50.

NOTE:

The radiator, cylinder and cylinder head are made of aluminum alloy. Using non-recommended engine coolant may corrode aluminum alloy and may clog the coolant passageways.

⚠ WARNING

Engine coolant is harmful if swallowed or if it comes in contact with your skin or eyes.

Keep engine coolant away from children and pets. Call your doctor immediately if engine coolant is swallowed and induce vomiting. Flush eyes or skin with water if engine coolant gets in eyes or comes in contact with skin.

COOLING SYSTEM INSPECTION

Inspect the following items before practice and races.

- Engine coolant leakage
- Radiator hose cracks and deterioration
- Radiator mounting condition
- Radiator breather hose condition
- Radiator fin condition

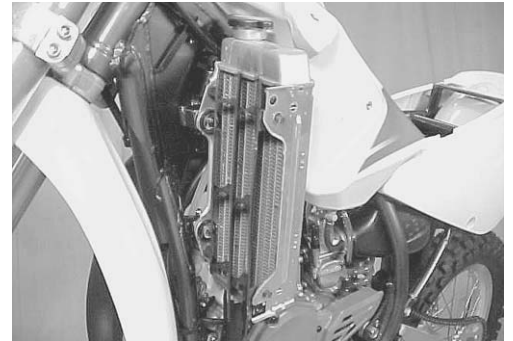

CLUTCH CABLE

Adjust the clutch cable play as follows:

MAJOR ADJUSTMENT

- Loosen lock-nut ①.
- Turn adjuster ② so the clutch lever has 10 – 15 mm (0.4 – 0.6 in) play at the clutch lever end before pressure is felt.
- Tighten lock-nut ①.

DATA Clutch lever play: 10 – 15 mm (0.4 – 0.6 in)

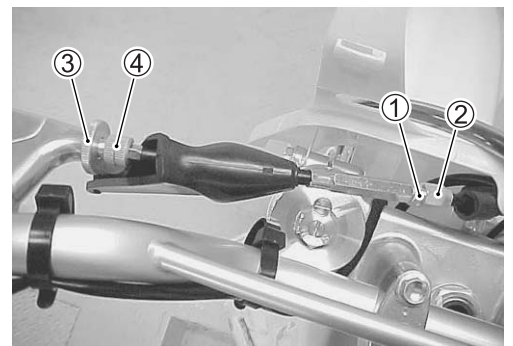

MINOR ADJUSTMENT

- Loosen lock-nut ③.
- Turn adjuster ④ so the clutch lever has 10 – 15 mm (0.4 – 0.6 in) play at the clutch lever end before pressure is felt.
- Tighten lock-nut ③.

DATA Clutch lever play: 10 – 15 mm (0.4 – 0.6 in)

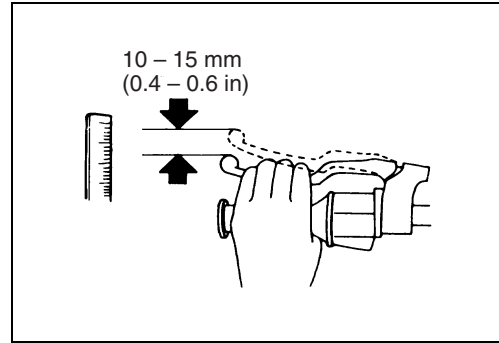

THROTTLE CABLE

▲ WARNING

Inadequate throttle cable play can cause engine speed to rise suddenly when you turn the handlebars. This can lead to loss of rider control.

Adjust the throttle cable play so that engine speed does not rise due to handlebar movement.

Adjust the throttle cable play as follows:

- Loosen lock-nut ①.
- Turn adjuster ② so the throttle grip has 2 – 4 mm (0.08 – 0.16 in) play in circumference.
- Tighten lock-nut ①.

DATA Throttle cable play: 2 – 4 mm (0.08 – 0.16 in)

- Remove the throttle housing cover.
- Apply oil to the throttle cable.
- Apply grease to the throttle cable spool.

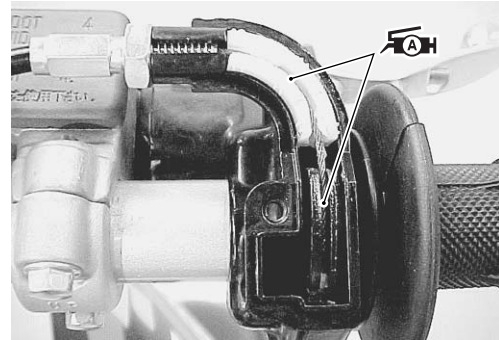
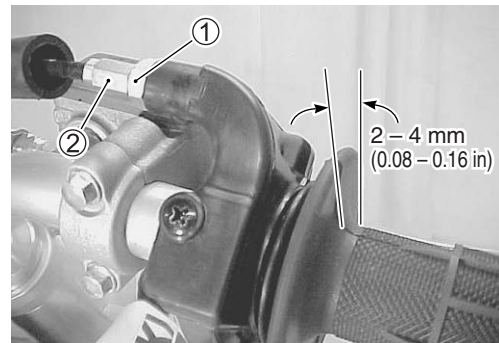

FUEL HOSE

- Inspect the fuel hose for damage and fuel leakage. If any defects are found, the fuel hose must be replaced with a new one.
- Replace the fuel hose every four years.

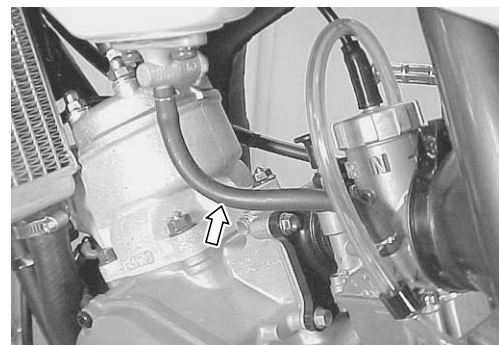

FUEL VALVE

- Drain the fuel.
- Disconnect the fuel hose ① and remove the fuel valve ②.

⚠ WARNING

**Gasoline is highly flammable and explosive.
Keep heat, sparks and flames away from gasoline.**

- Clean the fuel filter with compressed air.

CAUTION

The O-ring ③ must be replaced with a new one to prevent fuel leakage.

NOTE:

If the fuel filter is dirty with sediment, fuel will not flow smoothly.

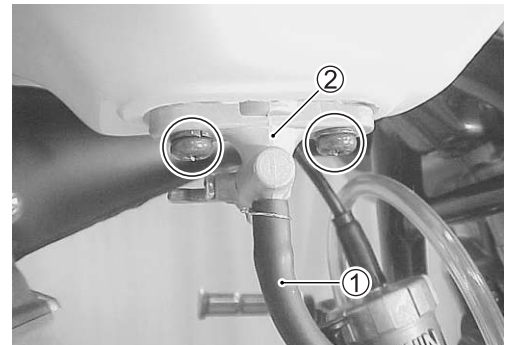

CYLINDER HEAD, CYLINDER AND PISTON

CYLINDER HEAD

- Remove the cylinder head. (🔧 6-3)
- Remove carbon deposits from the combustion chamber surface.
- Inspect for pinholes, cracks and other damage.



CYLINDER

- Remove the cylinder. (🔧 6-3)
- Remove carbon deposits from the exhaust port.
- Check for scratches and wear on the cylinder sleeve.

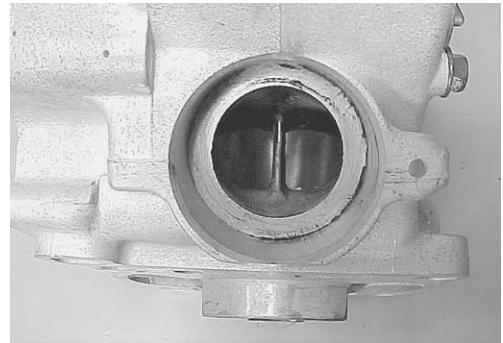

PISTON

- Remove the piston. (🔧 6-4)
- Remove carbon deposits from the top surface of the piston.
- Check for scratches, cracks, and wear around the piston bosses.
- Remove minor scuffs with #1 000 – #1 200 sand paper.
- Check piston ring wear. Remove carbon deposits from the piston ring groove.



EXHAUST VALVE

- Remove the exhaust valve. (🔧 6-4)
- Remove carbon deposits from the exhaust valve and exhaust valve guide.
- Check for wear and damage.
- Inspect the breather hose for clogging with tar. If clogging is found, clean up it.

NOTE:

Using several brands of engine oil may cause tar to drip from the breather hoses.



EXHAUST SILENCER

SILENCER INSPECTION AND REPLACEMENT

- Remove the seat and the right frame cover.
- Loosen the silencer mounting bolts and remove the silencer.
- Remove three bolts and extract the black frontal pipe from the aluminum case.



- Inspect the glass wool ① for clogging with carbon deposit or tar.
- Replace the glass wool ① with a new one, if necessary.

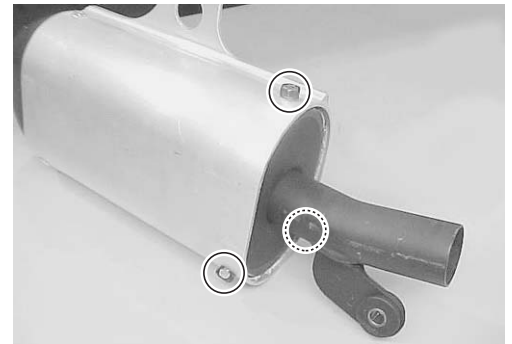

SILENCER REASSEMBLY

- Install the glass wool ① and the black frontal pipe to the aluminum case.
- Tighten three bolts.

NOTE:

To seal between the black frontal pipe flange and the aluminum case, apply SUZUKI BOND “1207B” to the contact area of the flange.

 99000-31140: SUZUKI BOND “1207B”

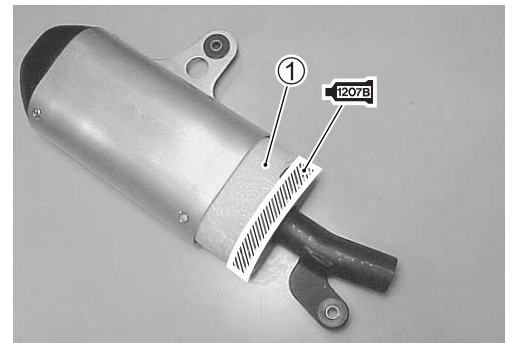

DRIVE CHAIN AND SPROCKETS

DRIVE CHAIN SLACK

- Place the motorcycle on the side stand.
- Inspect the drive chain slack at the middle point between the two sprockets.

 Drive chain slack: 40 – 50 mm (1.6 – 2.0 in)

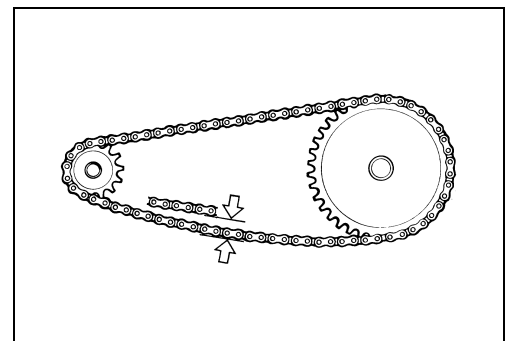

DRIVE CHAIN ADJUSTMENT

- Loosen the axle nut ①.
- Loosen the lock-nut ②.
- Adjust the drive chain slack to the specification by turning the adjusters ③.
- Check that both right and left alignment marks ④ are at the same position.
- Tighten the axle nut ① and lock-nut ②.

 **Axle nut: 72 N·m (7.2 kgf-m, 52.0 lb-ft)**

NOTE:

Pull the upper drive chain tight and lock it by placing a bar between the drive chain and rear sprocket while tightening the axle nut. This will help prevent the chain adjusters from coming to have play.

20TH PITCH LENGTH

- Pull the drive chain tight and measure the 20th pitch length.

 **Service Limit: 259 mm (10.2 in)**

DRIVE CHAIN LUBRICATION

- Remove the chain clip and master link from the drive chain and remove the drive chain.

NOTE:

Be careful not to bend the chain clip.

- Inspect for wear and damage of the drive chain and replace it if necessary.
- Clean the drive chain with non-flammable cleaning solvent.
- Do not use gasoline to clean the drive chain.
- Dry the drive chain.
- Apply Suzuki Chain Lube or an equivalent to the link plates and rollers.
- Reassemble the drive chain.

NOTE:

Reassemble the drive chain clip so the slit end faces opposite the direction of rotation.

- Adjust the drive chain slack. ( above)

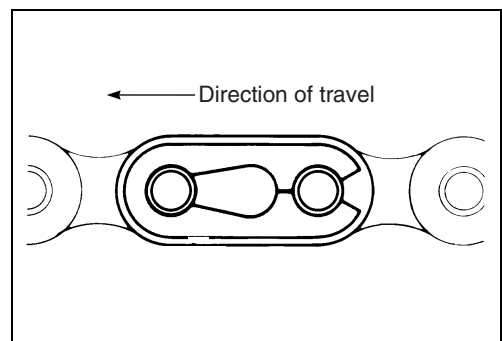
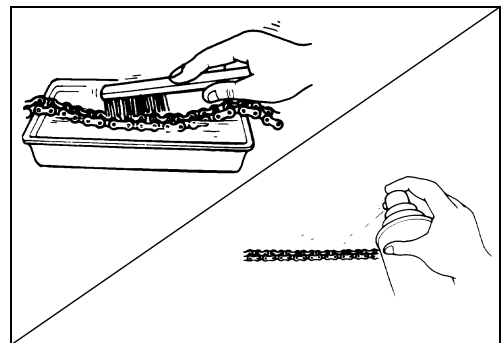
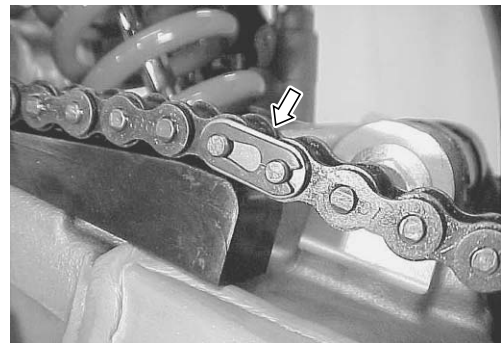
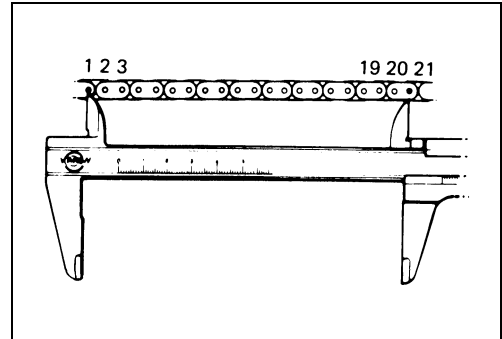
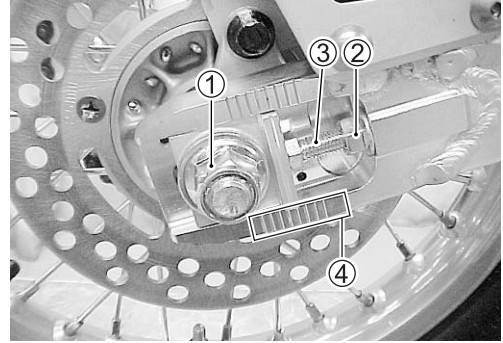

SPROCKET INSPECTION

- Inspect the engine sprocket and rear sprocket for wear and cracks. Replace the sprockets if necessary.

NOTE:

When replacing a worn sprocket, it is likely that the drive chain will need to be replaced as well.

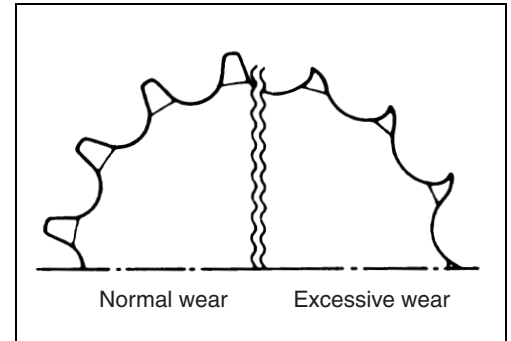
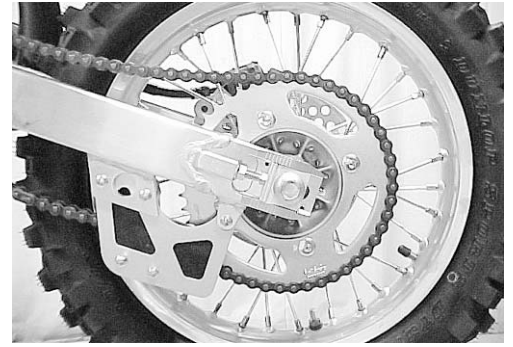

DRIVE CHAIN GUIDE, BUFFER, TENSIONER ROLLER

DRIVE CHAIN GUIDE

- Inspect the drive chain guide ① for bends and damage.

NOTE:

The drive chain can hit a bent guide causing noise and drive chain wear.

- Inspect the chain guide defense ② for wear.

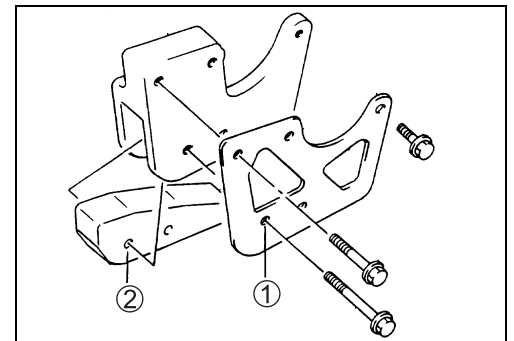

DRIVE CHAIN GUIDE BUFFER

- Inspect the drive chain guide buffer ③ for wear and cracks.

NOTE:

The drive chain can touch the swingarm directly if the chain guide buffer is worn out. This will cause drive chain and swing-arm damage.

DRIVE CHAIN TENSIONER ROLLER

- Inspect the drive chain tensioner rollers ④ for wear.
- Inspect the tensioner roller bolts for tightness.

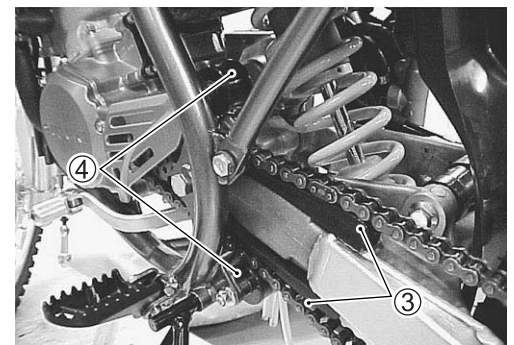

🔧 Drive chain tensioner roller bolts:

41 N·m (4.1 kgf·m, 29.5 lb-ft)

BRAKES

BRAKE FLUID LEVEL

- Inspect the brake fluid level in both front and rear reservoirs. If the brake fluid level is lower than LOWER (LWR) mark, replenish the reservoir with the specified brake fluid to the UPPER level. Inspect brake pad wear and brake fluid leakage if the brake fluid level decreases.

 Brake fluid: DOT 4

WARNING

Brake fluid can be hazardous to humans and pets. Brake fluid is harmful or fatal if swallowed, and harmful if it comes in contact with your skin or eyes.

Keep brake fluid away from children. Call your doctor immediately if brake fluid is swallowed, and induce vomiting. Flush eyes or skin with water if brake fluid gets in eyes or comes in contact with skin.

WARNING

The use of any fluid except DOT 4 brake fluid from a sealed container can damage the brake system and lead to an accident.

Use only DOT 4 brake fluid from a sealed container. Never use or mix different types of brake fluid.

CAUTION

Spilled brake fluid can damage painted surfaces and plastic parts.

Be careful not to spill any fluid when filling the brake fluid reservoir. Wipe spilled fluid up immediately.

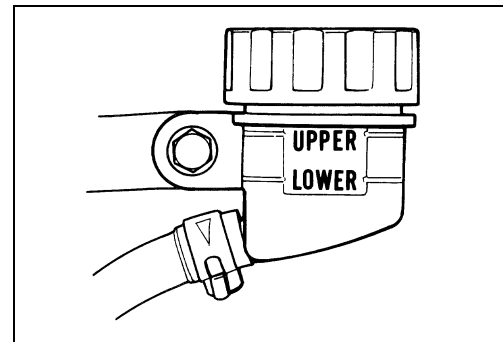
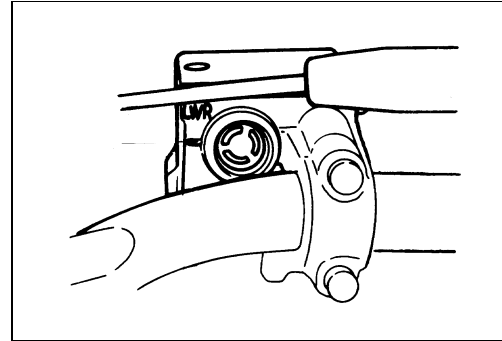

BRAKE PAD

- Inspect the brake pads for wear. If the brake pads are worn, replace them with new ones. (👉 15-4)

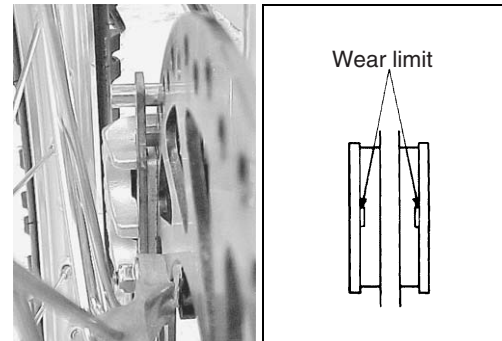

NOTE:

- * Pump the brake lever/pedal several times to restore the brake pads after replacing the brake pads.
- * Replace both right and left pads together when replacing the brake pads.

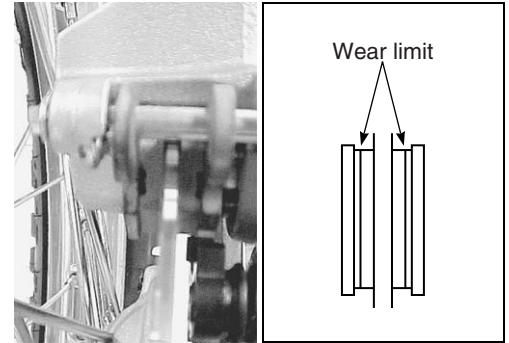

FRONT BRAKE LEVER ADJUSTMENT

Adjust the brake lever play as follows:

- Loosen lock-nut ①.
- Turn in or out adjuster ② to obtain the specified play.

DATA Brake lever play: 5 – 20 mm (0.20 – 0.79 in)

- Tighten the lock-nut ①.

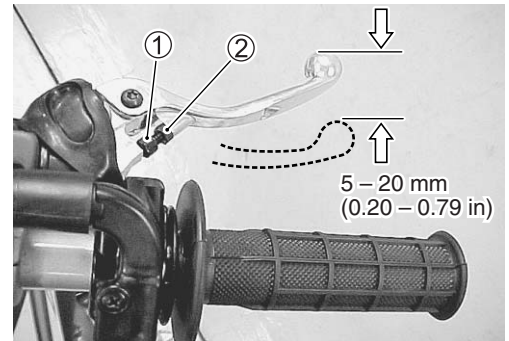

CAUTION

Brake lever play less than 5 mm (0.20 in) can cause brake dragging.

Do not adjust the brake lever play less than 5 mm (0.20 in).

BRAKE PEDAL HEIGHT ADJUSTMENT

Adjust the rear brake pedal height as follows:

- Loosen lock-nut ①.
- Adjust the brake pedal height by turning the adjuster ② to locate the pedal 0 – 10 mm (0 – 0.4 in) below the top face of the footrest.
- Tighten lock-nut ①.

🔧 Rear master cylinder rod lock-nut:

18 N·m (1.8 kgf·m, 13.0 lb·ft)

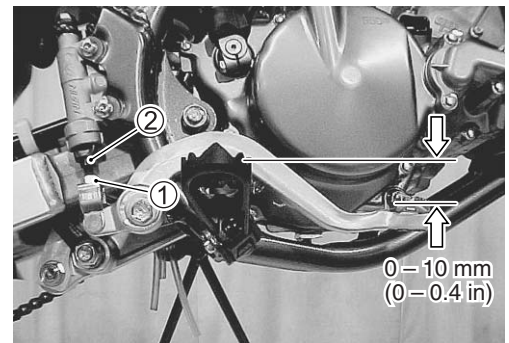

FRONT FORK

- Move the front fork up and down several times and inspect for smooth movement.
- Inspect for damage and oil leaks.
- Place a stand under the chassis tube to lift the front wheel off the ground.
- Remove the air bleed screw and equalize the air pressure in the front forks to atmospheric pressure. (👉 4-8)
- Refit the air bleed screw.
- Inspect the bolts and nuts for tightness.

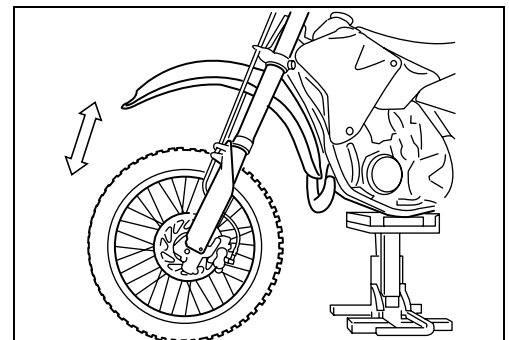

REAR SUSPENSION

- Move the rear suspension up and down several times and inspect for smooth movement.
- Inspect for damage and oil leaks.
- Inspect the bolts and nuts for tightness.



WHEELS AND TIRES

WHEEL RIM

- Inspect the wheel bearing for rattles. Replace the bearings if necessary. (👉 14-3 and -5)
- Inspect the wheel rim runout. (👉 14-3 and -5)

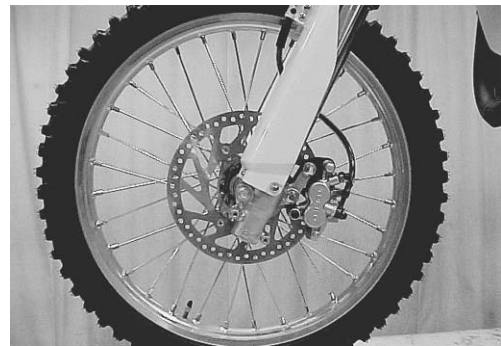

SPOKE NIPPLE AND RIM LOCK

- Inspect the spokes for tension by squeezing the spoke nipples.
- Retighten the spoke nipples with a spoke nipple wrench so as all spokes have same tension.

 **Spoke nipple: 4 N·m (0.4 kgf-m, 2.9 lb-ft)**

CAUTION

Improperly tightening the spoke nipples can damage the wheel.

Tighten the spoke nipples less than 1/2 turn at a time. Inspect the spoke tension and then retighten the spoke nipple.

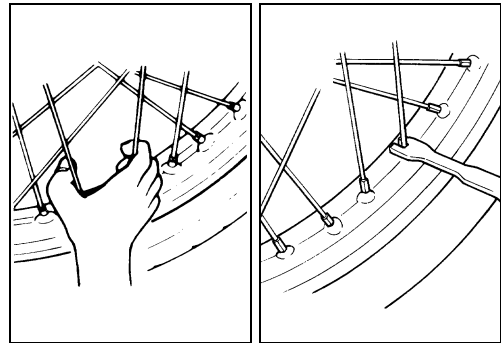

- Inspect the rim lock ① for tightness.

TIRE PRESSURE

- Inspect front and rear tire pressure.

 **Tire pressure (cold): 70 – 110 kPa
(0.7 – 1.1 kgf/cm², 10 – 16 psi)**

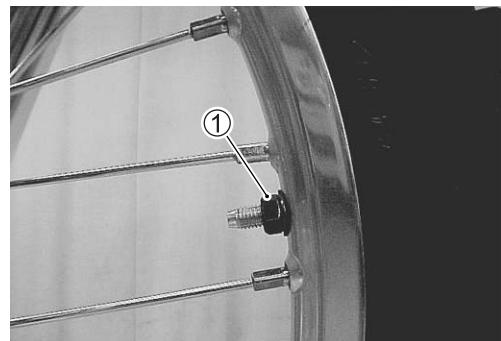

STEERING

- Inspect the steering by moving the front forward and backward, and right and left. If the steering has play or binds, inspect steering stem head nut tightness and steering bearings. (☞ 16-13)

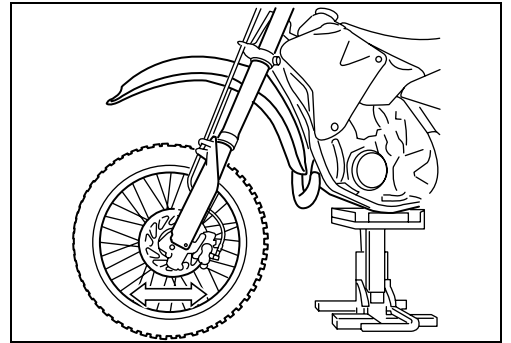

LUBRICATION

Apply grease or oil to the moving parts to increase durability and prevent wear.

No.	ITEM	LUBRICANT	FREQUENCY	COMMENTS
①	Inner cable ends, lever	A	Pre-race and between every race	Run oil through cables until it exits the lower end. Lube the cable ends where they pivot.
②	Throttle grip, throttle housing, cable	A	Pre-race	Lightly oil the inside of throttle spool. Keep free from dirt.
③	Rear brake pedal	C	Pre-race	Grease the brake pedal pivot.
④	Swingarm	C	Every 3 races/More often according to conditions	Clean and pack the bearings. Keep seals fresh. Grease the seals.
⑤	Rear suspension linkage pivot points	C	Every 3 races/More often according to conditions	Clean and pack the bearings. Keep seals fresh. Grease the seals.
⑥	Steering stem bearings	C	Every 5 races/More often according to conditions	Clean and pack the bearings. Keep seals fresh.
⑦	Starter shaft	A	Pre-race	Lightly oil the starter shaft.
⑧	Drive chain	B	Pre-race and between every race	Keep chain thoroughly lubed at all times. Always check wear and alignment.

The following materials are necessary:

- A. Lightweight oil such as WD-40 or penetrating oil.
- B. Suzuki chain lube or an equivalent
- C. Water-proof wheel bearing grease.

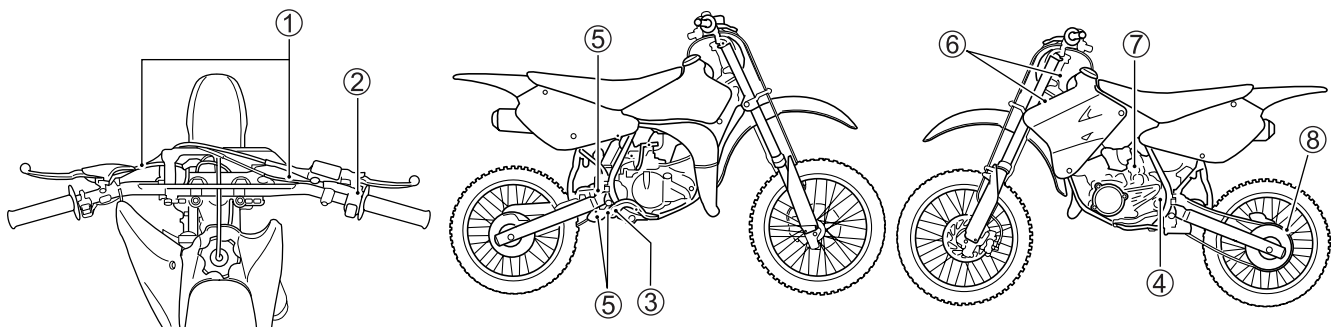

Follow the schedule closely. The disassembly necessary to lubricate many components is in itself valuable preventative maintenance. It allows you to inspect for wear, fatigue, adjustment and fastener tightness and it allows you to clean out the grit which otherwise cannot be gotten out.

▲ WARNING

Lubricating switches can damage the switches.

Do not apply grease and oil to the switches.

TIGHTENING TORQUE

PART	N·m	kgf-m	lb-ft
Cylinder head nut	28	2.8	20.5
Magneto rotor nut	35	3.5	25.5
Cylinder nut	25	2.5	18.0
Crankcase bolt	10	1.0	7.3
Clutch sleeve hub nut	70	7.0	50.5
Primary drive gear nut	70	7.0	50.5
Spark plug	28	2.8	20.5
Transmission oil drain plug	23	2.3	16.5
Transmission oil level screw	5.5	0.55	4.0
Water pump drain plug	5.5	0.55	4.0
Handlebars clamp bolt	26	2.6	19.0
Front fork upper clamp bolt (right and left)	23	2.3	16.5
Front fork lower clamp bolt (right and left)	23	2.3	16.5
Steering stem head nut	65	6.5	47.0
Front fork center bolt	55	5.5	40.0
Fork cylinder inner rod lock-nut	20	2.0	14.5
Front fork cap bolt	35	3.5	25.5
Master cylinder mounting bolt (front)	10	1.0	7.3
Master cylinder mounting bolt (rear)	10	1.0	7.3
Rear master cylinder rod lock-nut	18	1.8	13.0
Brake hose adaptor (front)	18	1.8	13.0
Brake hose union bolt (front and rear)	23	2.3	16.5
Brake caliper mounting bolt (front)	23	2.3	16.5
Brake caliper mounting bolt (rear)	23	2.3	16.5
Brake bleeder valve (front and rear)	7.5	0.75	5.5
Disc mounting screw (front and rear)	8.5	0.85	6.0
Disc mounting nut (front)	8.5	0.85	6.0
Front axle nut	44	4.4	32.0
Engine mounting nut (front)	45	4.5	32.5
Engine mounting nut (middle)	43	4.3	31.0
Rear axle nut	72	7.2	52.0
Rear sprocket nut	40	4.0	29.0
Drive chain tensioner roller bolt	41	4.1	29.5
Spoke nipple	4	0.4	3.0
Rear swingarm pivot nut (engine mounting)	58	5.8	42.0
Rear shock absorber mounting nut (upper and lower)	60	6.0	43.5
Rear cushion lever center nut	80	8.0	58.0
Rear cushion lever front nut	60	6.0	43.5
Rear cushion rod nut	80	8.0	58.0

For other bolts and nuts not listed in the table, refer to this chart.

Bolt Diameter (mm)	Conventional or "4" marked bolt			"7" marked or crown headed bolt		
	N·m	kgf-m	lb-ft	N·m	kgf-m	lb-ft
4	2.0	0.2	1.5	2.0	0.2	1.5
5	3.0	0.3	2.0	5.0	0.5	3.5
6	6.0	0.6	4.5	10.0	1.0	7.0
8	13.0	1.3	9.5	23.0	2.3	16.5
10	29.0	2.9	21.0	50.0	5.0	36.0
12	45.0	4.5	32.5	85.0	8.5	61.5
14	65.0	6.5	47.0	135.0	13.5	97.5
16	105.0	10.5	76.0	210.0	21.0	152.0
18	160.0	16.0	115.5	240.0	24.0	173.5

TROUBLESHOOTING

CONTENTS

TROUBLESHOOTING	3- 2
ENGINE	3- 2
CHASSIS	3- 5

TROUBLESHOOTING ENGINE

Complaint	Possible Cause	Remedy
Engine does not start or hard to start	Fuel deterioration No fuel flow to the carburetor <ul style="list-style-type: none"> • Fuel valve clogged • Fuel hose clogged • Fuel tank cap breather hose clogged • Carburetor float valve malfunction Carburetor overflow pipe clogged Carburetor air vent pipe clogged Too rich air/fuel mixture in combustion chamber Incorrect ignition timing No spark at spark plug Low compression <ul style="list-style-type: none"> • Piston ring worn or stuck • Cylinder worn • Air leak from cylinder gasket • Air leak from crankshaft oil seal 	Replace Clean Clean or replace Clean Replace Clean Clean Scavange Adjust  13-1 Replace Replace or rebore Replace Replace
Engine stalls	Fuel deterioration Fouled spark plug Fuel hose clogged Air cleaner clogged Carburetor jets clogged Low compression <ul style="list-style-type: none"> • Piston ring worn or stuck • Cylinder worn • Air leak from cylinder gasket • Air leak from crankshaft oil seal Incorrect ignition timing Carburetor fuel level maladjustment	Replace Clean or replace Clean or replace Clean or replace Clean Replace Replace or rebore Replace Replace Adjust Adjust
Insufficient power	Carburetor fuel level maladjustment Fuel deterioration Brake dragging Exhaust pipe cracked or clogged with carbon Exhaust valve maladjustment Exhaust valve carbon deposits Air cleaner element clogged Carburetor jets clogged Incorrect fuel level in carburetor Incorrect spark plug gap Cylinder or piston ring worn Reed valve malfunction Incorrect ignition timing	Adjust Replace Adjust Replace or clean Adjust Clean Clean or replace Clean or replace Adjust Adjust or replace Replace Replace Adjust

Complaint	Possible Cause	Remedy
Engine runs poorly in low speed range	Wide spark plug gap Carburetor air screw maladjustment Incorrect carburetor fuel level Improper jet needle size Incorrect ignition timing CDI unit malfunction Ignition coil damage Magneto malfunction Magneto short circuit	Adjust or replace Adjust Adjust Replace Adjust Replace Replace Replace Replace
Engine runs poorly in high speed range	Narrow spark plug gap Incorrect carburetor fuel level Retarded ignition timing CDI unit malfunction Ignition coil damage Air cleaner element clogged Magneto short circuit Exhaust pipe cracked Exhaust valve malfunction Piston ring stuck	Adjust or replace Adjust Adjust Replace Replace Clean or replace Replace Replace Clean, adjust or replace replace Replace
Exhaust valve does not work	Carbon deposits on exhaust valve Exhaust valve damage Governor damage Exhaust valve shaft damage Valve spring damage	Clean Replace Replace Replace Replace
Spark plug does not ignite	Ignition coil malfunction Spark plug malfunction Generator malfunction CDI unit malfunction Wide spark plug gap Engine stop switch malfunction	Replace Replace Replace Replace Adjust Repair or replace
Carbon deposits on spark plug porcelain	Too rich air/fuel mixture Too rich oil/gasoline mixture Improper spark plug heat range	Adjust Adjust Replace
Spark plug electrode damage	Improper spark plug heat range Overheating Incorrect ignition timing Loose spark plug Too lean air/fuel mixture	Replace ☞ 3-4 Adjust Tighten Adjust

Complaint	Possible Cause	Remedy
Overheating	Low engine coolant level Engine coolant leak Too lean air/fuel mixture Incorrect ignition timing Water pump malfunction Cylinder head carbon deposits Cylinder head O-ring damage Exhaust pipe carbon deposits Improper spark plug heat range Fuel deterioration Clutch slipping Radiator cap loose Radiator fins damaged	Replenish Repair Adjust Adjust Adjust or replace Clean Replace Clean or replace Replace Replace Adjust or replace Tighten Repair or replace
Excessive coolant level decrease	Radiator hose cracked or damaged Loose radiator hose connection Radiator cracked or damaged Water pump cover mating surface damage Water pump cover crack Water pump cover gasket damage Water seal wear or damage Radiator cap seal damage Incorrect radiator cap valve pressure Cylinder or cylinder head cracked Cylinder or cylinder head O-rings damage	Replace Repair Repair or replace Replace Replace Replace Replace Replace Replace Replace Replace
Clutch does not disengage	Clutch lever play maladjustment Clutch spring damage Clutch plates distortion	Adjust Replace Replace
Clutch slipping	Clutch cable play maladjustment Weakened clutch spring Clutch pressure plate wear Clutch plates distortion Clutch plates worn	Adjust Replace Replace Replace Replace
Transmission does not shift	Gearshift cam damage Gearshift fork distortion Gearshift pawl wear	Replace Replace Replace
Transmission gears jump out	Gearshift fork groove wear or damage Gearshift fork distortion or wear Gearshift cam stopper damage	Replace Replace Replace
Gearshift lever does not return	Weakened gearshift return spring Gearshift lever sticking	Replace Repair or replace

CHASSIS

Complaint	Possible Cause	Remedy
Heavy handling	Steering stem nut overtightened Steering head bearings damaged or rusted Steering stem distortion	Adjust Replace Replace
Front wheel wobbling	Loose spoke nipples Wheel distortion Front wheel bearing damage Incorrect axle tightening torque	Adjust Replace Replace Retighten
Rear wheel wobbling	Loose spoke nipples Wheel distortion Rear wheel bearing damage Swingarm pivot bearing damage Incorrect axle tightening torque Incorrect swingarm tightening torque	Adjust Replace Replace Replace Retighten Retighten
Soft front suspension	Weakened spring Low oil level Low fork oil viscosity Damping force maladjustment Damping valve malfunction Standard spring too soft	Replace Replenish Replace Adjust Replace * Use optional spring
Hard front suspension	High fork oil level High fork oil viscosity Damping force maladjustment Inner tube distortion	Adjust Replace Adjust Replace
Soft rear suspension	Weakened spring Damping force maladjustment Low gas pressure Standard spring too soft	Replace Adjust Adjust * Use optional spring
Hard rear suspension	Damping force maladjustment Damper rod distortion Rear suspension pivoting portion out of grease Standard spring too stiff	Adjust Replace Lubricate * Use optional spring
Poor braking	Brake pads worn Improper air bleeding Dirty pads and disc Brake fluid leak	Replace Bleed air Clean Repair
Brake noise	Brake pads worn Brake disc worn Dirty brake pads and disc	Replace Replace Clean

* Optional stiffer and softer springs are available.

- MEMO -

MACHINE TUNING

CONTENTS

CARBURETOR TUNING	4- 2
PRINCIPLES OF CARBURETOR TUNING	4- 2
CARBURETOR TUNING IN PRACTICE	4- 5
FRONT FORK TUNING	4- 8
FRONT FORK	4- 8
FRONT FORK SPRING REPLACEMENT AND OIL LEVEL ADJUSTMENT	4- 9
REAR SUSPENSION TUNING	4-13
REAR SUSPENSION	4-13
SUSPENSION BALANCE	4-16
BALANCE TEST	4-16
BALANCING TIPS	4-16

CARBURETOR TUNING

The carburetion of your motorcycle was carefully selected after extensive testing. You will find that the carburetion will function smoothly under many varied operating conditions. For best results we recommend that the adjustments and carburetion jetting be left "as is" from the factory.

Some riders may operate their motorcycle under extreme operating conditions such as; very high altitudes or extreme cold and hot temperatures. In these circumstances the jetting of the carburetor or other adjustments may need to be altered slightly. Riders who are not familiar with the operation and jetting procedures of the KEIHIN carburetor should have their local authorized Suzuki dealer perform these alterations. Mechanically experienced riders can alter the carburetor settings based on the following information and specifications.

Carburetor Specifications

Bore	28 mm
Main jet	#128
Jet needle	24NAAH-3rd
Slow jet	#50
Air screw	2 turns out
Float height	19 mm (0.75 in)
Setting parts (included parts)	
main jet:	#125, #130, #135

PRINCIPLES OF CARBURETOR TUNING

CARBURETOR COMPONENTS AND FUNCTIONS

The carburetor consists of a number of parts as shown below. The asterisk (*) marked parts are precisely machined, which meter the intake air (oxygen) and fuel so that the air/fuel mixture ratio is controlled accurately. They can be divided by three operation-related groups; pilot (slow) system, intermediate system and main system, and they achieve their functions in each corresponding throttle opening range. It is necessary to have a full understanding of them for proper carburetor tuning.

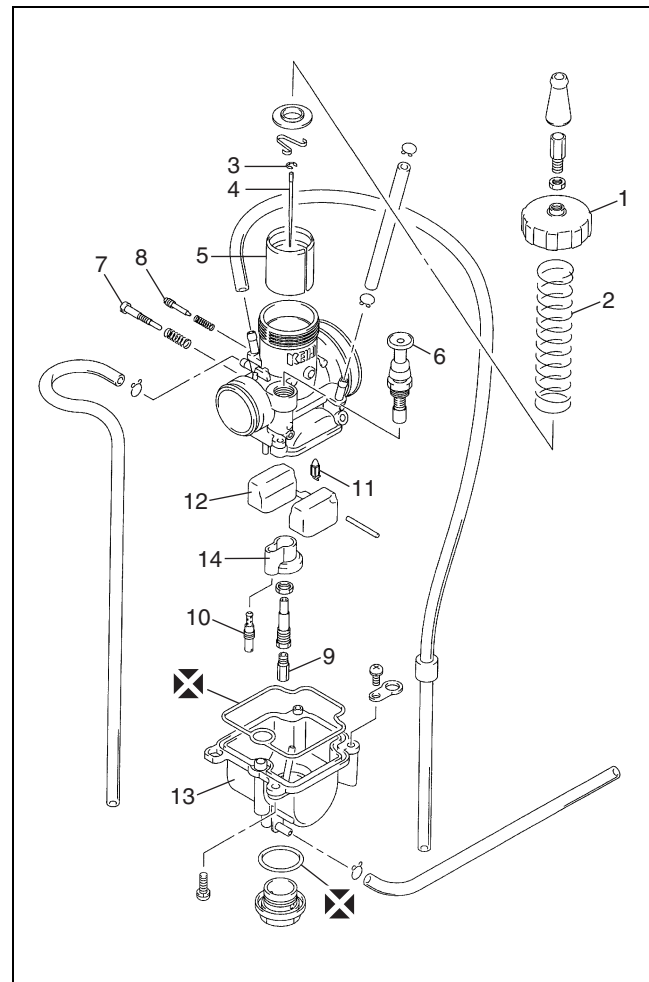

- | | |
|------------------------|-------------------|
| 1. Top cap | 8. * Air screw |
| 2. Spring | 9. * Main jet |
| 3. * Clip | 10. * Slow jet |
| 4. * Jet needle | 11. Needle valve |
| 5. Throttle valve | 12. Float |
| 6. Starter knob | 13. Float chamber |
| 7. Throttle stop screw | 14. Jet holder |

As shown below, each tuning parts is located between the air/fuel passage and has its own air/fuel mixture adjustable range in terms of the throttle valve opening. The chart indicates that the carburetor can supply correct air/fuel mixture to the engine in any range because of the overlapping adjustable range of the each part.

TUNING PARTS	THROTTLE VALVE OPENING			
MAIN JET			①	
NEEDLE JET	③			
NEEDLE CLIP POSITION		②		
SLOW JET AND AIR SCREW	③			
THROTTLE OPENING	1/8	1/4	1/2	3/4

① MAIN SYSTEM ② INTERMEDIATE SYSTEM ③ PILOT SYSTEM

When performing carburetor turning first find out in what throttle opening range an improper air/fuel mixture is supplied, by checking the color of exhaust smoke, spark plug, throttle response, power, etc. Second, replace or adjust the part(s) related to the throttle opening range by referring to the following instructions. The sizes referred to in the illustrations are those of standard setting.

SLOW JET

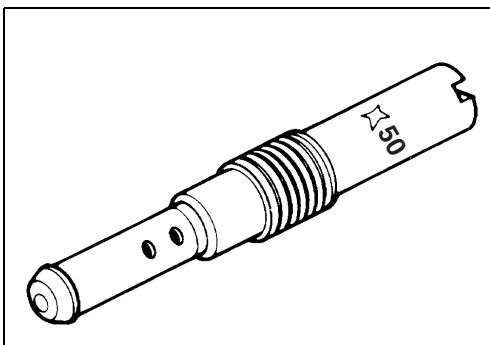

The pilot jet meters the fuel supplied to the pilot system. Each jet size is indicated by a number. Larger number means a larger bore diameter and fitting a larger numbered pilot jet enriches the air/fuel mixture.

AIR SCREW

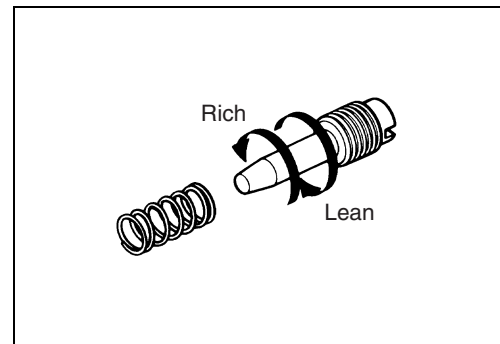

AIR SCREW

The pilot air screw is located in the inlet air passage and meters the air for the pilot system. As it has a right-hand thread, tightening it makes the passage narrower, allowing less amount of intake air to flow and resulting in richer air/fuel mixture. Air flow adjustment is effective within a range of 1/2 – 2 and 1/4 turns out.

JET NEEDLE

When the throttle opening is 1/4 to 3/4, the air/fuel mixture ratio varies depending on the fuel volume which the vacuum at the needle jet draws through the needle jet-to-needle clearance.

NEEDLE CLIP POSITION

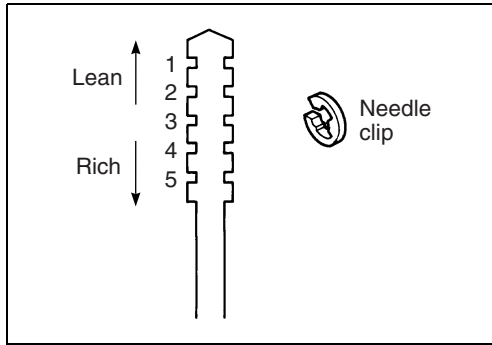

The jet needle is linked to the throttle valve by means of the needle clip. Its lower part is tapered and it has five grooves cut in the upper part where the needle clip fits.

To adjust the air/fuel mixture with the jet needle, change position of the needle clip which is set in the 3rd groove. The lower groove the clip is moved to, the higher the jet needle rises and the larger the clearance with the needle jet becomes, resulting in a richer air/fuel mixture ratio.

The needle clip position can be changed by half to fine-tune the setting. To change the needle clip position by half, change jet needle from 24NAAH type to 24NCDH type. This change will move the needle position by half to the leaner side.

Air/fuel mixture	Needle type and clip position
↑ Lean Rich ↓	24NCDH-1st
	24NAAH-1st
	24NCDH-2nd
	24NAAH-2nd
	24NCDH-3rd
	24NAAH-3rd
	24NCDH-4th
	24NAAH-4th
	24NCDH-5th
	24NAAH-5th

JET NEEDLE

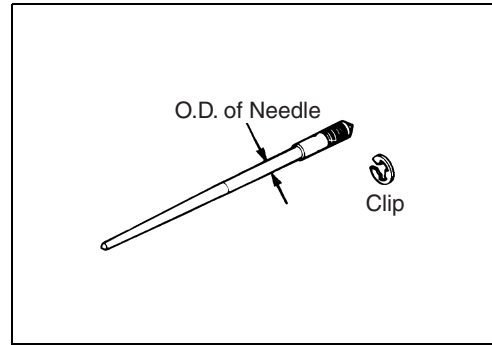

NEEDLE NUMBER

24NAAH — O.D.

Changing the needle itself controls air/fuel mixture ratio particularly on lower mid-throttle opening. The smaller the O.D., the richer the air/fuel mixture becomes.

Air/fuel mixture	Needle Number	O.D.
↑ Lean Rich ↓	24NAAK/24NCDK	2.415 mm
	24NAAJ/24NCDJ	2.405 mm
	24NAAH/24NCDH	2.395 mm
	24NAAG/24NCDG	2.385 mm
	24NAAF/24NCDF	2.375 mm

MAIN JET

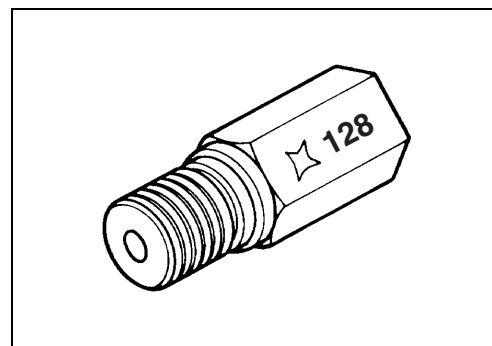

The main jet, like the pilot jet, meters fuel flow.

CARBURETOR TUNING IN PRACTICE

In the previous section, basic principles of carburetor tuning have been discussed. Described in this section are the bases for carburetor tuning required when coping with variations in air (oxygen) concentration.

VARIATION IN AIR (OXYGEN) CONCENTRATION AND CARBURETOR CONDITIONS

As the air, affected by the temperature, altitude and humidity, gets expanded or compressed, air (oxygen) concentration varies accordingly. Each of these three factors affects the air in different ways, and the following graphs show their effects respectively in terms of the oxygen concentration.

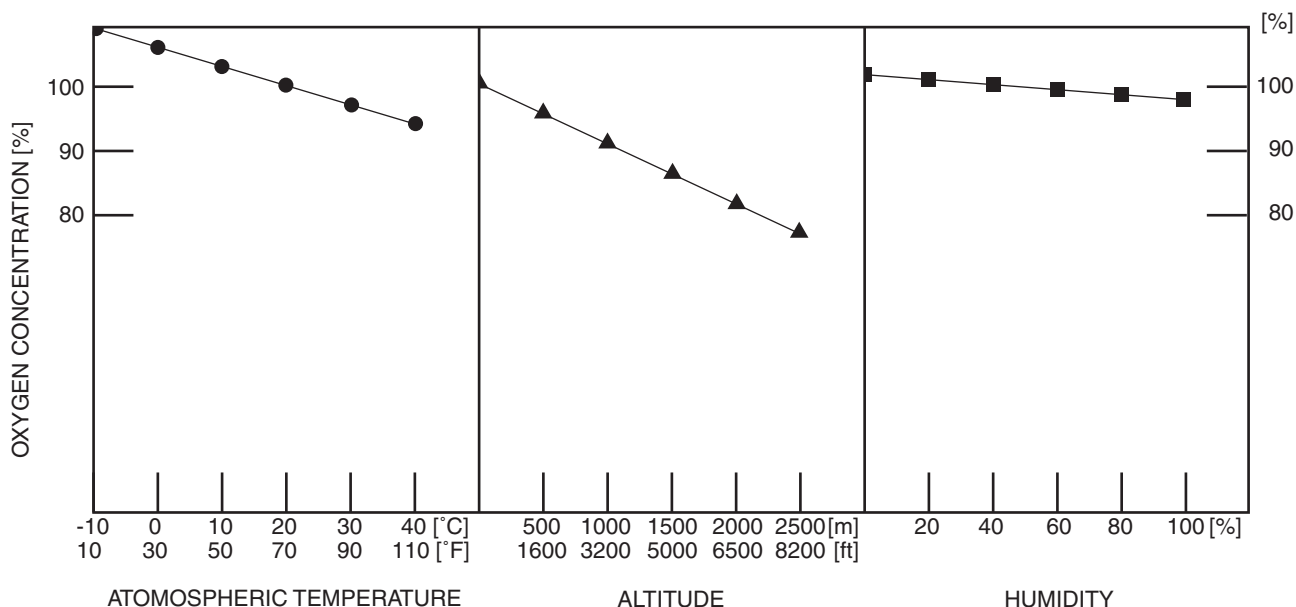

In the above graphs, oxygen concentration is graduated on the vertical axis while the temperature, altitude and humidity are on the horizontal axis respectively. Oxygen concentration is set 100% under the conditions of 20 °C (68 °F), 0 m (0 ft) and 50% humidity. The standard carburetor setting is chosen to obtain the best engine performance under these conditions.

The graph at the left shows that the oxygen concentration changes about 10% in the 0 to 40 °C temperature difference, the one in the center shows about 20% change in the 0 to 2 000 m altitude difference and the one at the right shows about 5% change in the 0 to 100% humidity difference. As for humidity, its normal range is from 20 to 95%. Therefore the possible effect of humidity on the oxygen concentration is so little that it can be disregarded. Consequently, we can say that the oxygen concentration varies by as much as 20% depending on the temperature and altitude under normal riding conditions. On the other hand, different from the air, the fuel (gasoline) hardly changes in volume even when such environmental conditions change. Therefore, increase in oxygen concentration will make the air/fuel mixture richer and decrease will make it lean.

As the carburetor mixes gasoline and air, which are metered by each jet in varying proportions to suit throttle opening, the air/fuel mixture is affected if the air concentration itself varies as described above. Then proper engine power output can not be attained and, should the mixture become too lean, a piston seizure may result. To compensate for such change in the air concentration, it is required to carry out carburetor tuning beforehand. This requirement applies to all models of motorcycles and ATVs if they are used in areas where temperature and altitude range widely. The next section describes the procedure of the above tuning in detail.

JUDGING AIR/FUEL MIXTURE

For proper carburetor tuning, it is necessary to know how to judge the air/fuel mixture made in the carburetor; whether too rich, too lean or properly mixed. Given below are the symptoms observed when the engine is not supplied with the proper air/fuel mixture ratio from the carburetor. Check each item as reference for judging the air/fuel mixture condition.

When air/fuel mixture is too rich

- 1) The engine noise is dull and intermittent.
- 2) The engine condition becomes worse when the starter is applied.
- 3) The engine condition becomes worse as it is warmed up.
- 4) The engine condition improves when the air cleaner is removed.
- 5) The spark plug is fouled with carbon (wet and oily).
- 6) The exhaust gas produces heavy smoke.

When air/fuel mixture is too lean

- 1) The engine overheats.
- 2) The engine condition improves when the starter is applied.
- 3) Acceleration is poor.
- 4) The spark plug is burned white.
- 5) The speed of the engine fluctuates and lack of power is noticed.
- 6) Detonation and pinging are experienced.

TUNING PROCEDURE

The following indicates the correct tuning procedure for this motorcycle. Understand the procedure by first riding the motorcycle where it will be used and adjust the engine to the best condition after judging the air/fuel mixture.

Carburetor standard setting

- Main jet: #128
- Jet needle: 24NAAH-3rd
- Slow jet: #50
- Air screw: 2 turns out

INCLUDED PARTS AND OPTIONAL PARTS

Main jet

Air/fuel mixture	SIZE	P/NO
	#115	09491-23027
	#118	09491-23028
	#120	09491-24030
	* #122	09491-24031
	#125	09491-25019
	#128	09491-25020
	* #130	09491-26017
	#132	09491-26018
	* #135	09491-27016
	#138	09491-27017
	#140	09491-28019
	#142	09491-28020
	#145	09491-29014

Slow jet

Air/fuel mixture	SIZE	P/NO
	#45	09492-45032
	#48	09492-48013
	#50	09492-50023
	#52	09492-52011
	#55	09492-55017
	#58	09492-58001

Jet Needle

Air/fuel mixture	SIZE	P/NO
	24NCDK	13383-03B90
	24NAAK	13383-03B40
	24NCDJ	13383-03B80
	24NAAJ	13383-03B30
	24NCDH	13383-03B70
	24NAAH	13383-03B20
	24NCDG	13383-03B60
	24NAAG	13383-03B10
	24NCDF	13383-03B50
	24NAAF	13383-03B00

NOTE:

SHADED : STANDARD

* : INCLUDED PARTS

NONE : OPTIONAL PARTS

① Adjustment of slow system

- 1) Set the air screw as specified.
- 2) See if the selected slow jet is correct or not by judging the air/fuel mixture. If air/fuel mixture is rich, replace it with smaller one. If air/fuel mixture is lean, replace it with larger one.

Ex. Pilot jet #50

If air/fuel mixture is rich, replace it with #48 slow jet. If air/fuel mixture is lean, replace it with #52 slow jet.

② Adjustment of main system

With the throttle opened 3/4 to full, make main system adjustment monitoring the air/fuel mixture condition after completion of pilot system settings.

- * If selection of the main jet is between the columns, take the larger number main jet first to prevent the piston seizure.
- * Make sure to adjust the main system before adjusting the intermediate system.

Ex. Main jet #128

If air/fuel mixture is rich, replace it with #125 main jet. If air/fuel mixture is lean, replace it with #130 main jet.

③ Adjustment of intermediate system

Monitor the air/fuel mixture condition and adjust the intermediate system by selecting the proper needle size. Changing standard needle within one size (larger or smaller) will cover almost any race condition.

④ Fine adjustment of slow system

After a proper standard setting has been obtained by the procedure ① through ③, fine tune the carburetor according to the actual race conditions.

- 1) Adjust the air/fuel mixture by tuning the air screw within 1/2 – 2 turns out.
 - 1/2 turn out
 - 1 – 1/2 turns out
 - 2 turns out
- 2) If the mixture can not be adjusted by the air screw within 1/2 – 2 and 1/4 turns out range, readjust the pilot system ③.

⑤ Fine adjustment of intermediate system

Fine tune the intermediate system by changing the clip position.

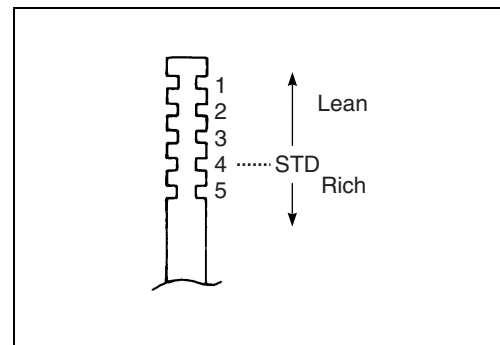

FRONT FORK TUNING

FRONT FORK

The front fork compression and rebound damping force, and oil quantity are adjustable for rider's preference, rider's weight and course condition.

NOTE:

- * Break-in new front forks before attempting adjustment.
- * Be sure to adjust both right and left front forks equally.

COMPRESSION DAMPING FORCE ADJUSTMENT

- Turn the adjuster screw ① clockwise until it stops. It is the stiffest position.

NOTE:

To set the adjuster, you must gently turn the adjuster screw clockwise until it stops, then back it out the recommended number of turns. Do not force the adjuster screw past the stopped position or you may damage the adjuster.

- Turn the adjuster screw out to the standard position.

DATA Standard setting: 7 clicks out from the stiffest position.

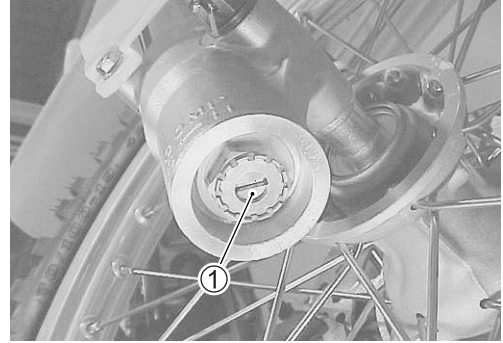

REBOUND DAMPING FORCE ADJUSTMENT

- Turn the adjuster screw ② clockwise until it stops. It is the stiffest position.

NOTE:

To set the adjuster, you must gently turn the adjuster screw clockwise until it stops, then back it out the recommended number of turns. Do not force the adjuster screw past the stopped position or you may damage the adjuster.

- Turn the adjuster screw out to the standard position.

DATA Standard setting: 1 and 1/2 turns out from the stiffest position



AIR PRESSURE ADJUSTMENT

- Place a block under the chassis tube to lift the front wheel off the ground.
- Remove the air bleed screw ③ and equalize the air pressure in the front forks to atmospheric pressure.
- Re-fit the air bleed screw.

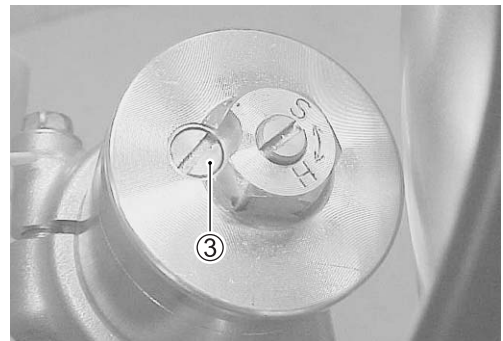

FRONT FORK SPRING REPLACEMENT AND OIL LEVEL ADJUSTMENT

- Remove the front forks, left and right. (👉 16-3)
- Thoroughly clean the fork before disassembly.

CAUTION

Scratches or other damage on the inner tube or on the oil seal lip will cause oil leak.

Avoid scratching or damaging the inner tube or the oil seal. Use a mild detergent or car wash soap and sponge out dirt with plenty of water.

- Drain fork oil. (👉 16-4)
- Place the front fork vertically without spring.
- Compress it fully.
- Pour specified front fork oil up to the top level of the outer tube.

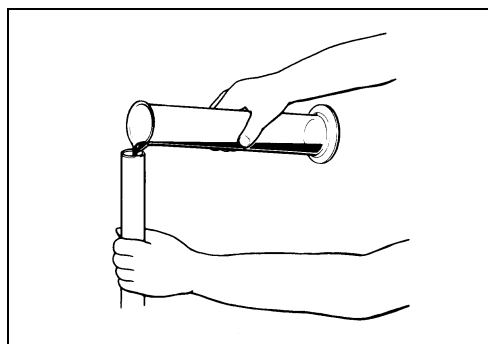

- Move the inner rod slowly with the special tool more than ten times until no more bubbles come out from the oil.

TOOL 09940-52841: Inner rod holder

NOTE:

Refill front fork oil up to the top of the outer tube to find bubbles while bleeding air.

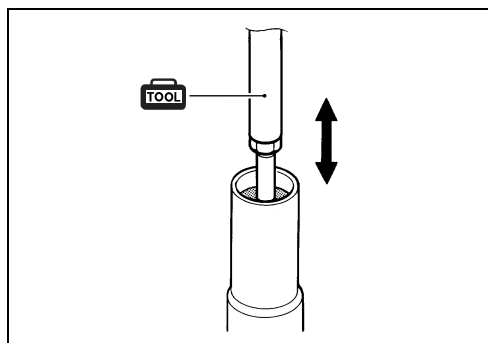

- Refill specified front fork oil up to the top level of the outer tube again. Move the outer tube up and down several strokes until no more bubbles come out from the oil.
- Keep the front fork vertically and wait 5 – 6 minutes.

NOTE:

- * Always keep oil level over the cartridge top end, or air may enter the cartridge during this procedure.
- * Take extreme attention to pump out air completely.

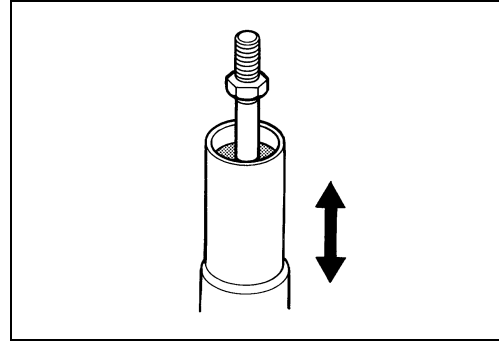

- Hold the front fork vertically and adjust fork oil level with the special tool.

NOTE:

When adjusting the fork oil level, compress the outer tube fully without the fork spring.

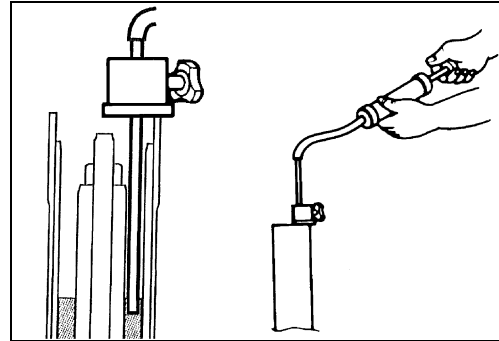

TOOL 09943-74111: Front fork oil level gauge

FORK 99000-99001-SS5: SUZUKI FORK OIL SS-05
or an equivalent fork oil

DATA

SPRING		STANDARD OIL LEVEL	OIL LEVEL ADJUSTABLE RANGE
STANDARD SPRING: 2.8 N/m (0.28 kgf/mm)		124 mm (4.88 in)	114 – 147 mm (4.49 – 5.79 in)
SOFTER SPRING: 2.6 N/m (0.26 kgf/mm)	OPTIONAL SPRING: 51171-03B30	120 mm (4.72 in)	110 – 144 mm (4.33 – 5.67 in)
STIFFER SPRING: 3.0 N/m (0.30 kgf/mm)	OPTIONAL SPRING: 51171-03B60	130 mm (5.12 in)	117 – 148 mm (4.60 – 5.83 in)

NOTE:

- * Be sure to adjust the fork oil level within the above-mentioned range, the front fork performance will deteriorate.
- * The oil level should be increased or decreased by 3 mm (0.12 in) at a time.
- * Make sure that the oil level is the same as both fork legs.

- Pull up the inner rod with the special tool.

TOOL 09940-52841: Inner rod holder

- Install the fork spring.

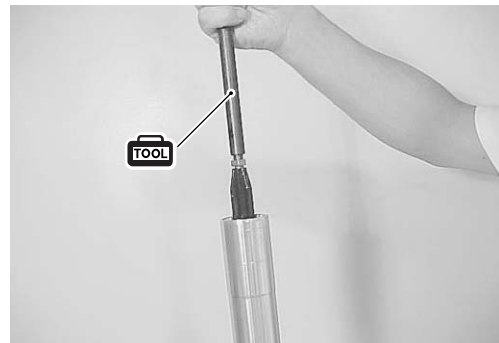

- Adjust the height H of the inner rod threads by turning the lock-nut ①.
- H : 14 mm

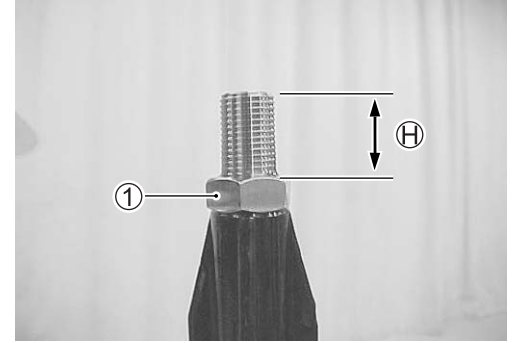

- Set the rebound damping adjuster 1.5 mm (0.06 in) as shown before assembling the front fork cap.
- Slowly turn the fork cap bolt ② to seat at the lock-nut ③ by hand tightening.

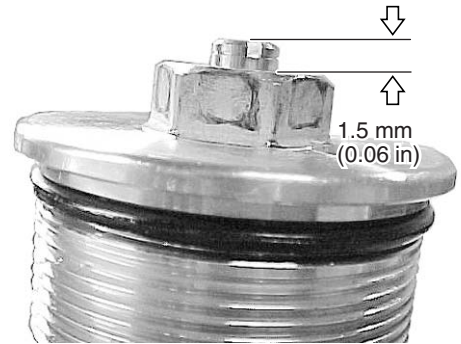

CAUTION

Be sure to adjust the rebound damping force adjuster to the softest position before installing the fork cap bolt.

- Hold the fork cap bolt and tighten the lock-nut to the specified torque.

🔧 Inner rod lock-nut: 20 N·m (2.0 kgf·m, 14.5 lb-ft)

- Apply fork oil to the fork cap's O-ring.
- Tighten the fork cap bolt to the specified torque.

🔧 Fork cap bolt: 35 N·m (3.5 kgf·m, 25.5 lb-ft)

- Remount the front forks to the steering stem. (👉 16-10)

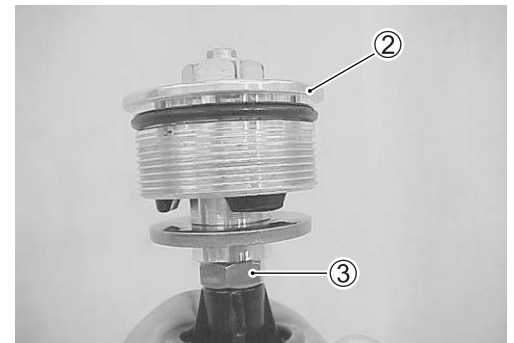

OPTIONAL SPRING

The number of end coils shows the fork spring rate.

SOFTER SPRING	STANDARD SPRING	STIFFER SPRING
2.6 N·m (0.26 kgf/mm)	2.8 N·m (0.28 kgf/mm)	3.0 N·m (0.30 kgf/mm)

FRONT FORK TUNING PROCEDURE

Test ride the motorcycle and find out how the front suspension reacts on various types of surface. According to the symptom noticed, adjust the front fork to the best setting for rider and race track conditions. To adjust, attempt changing fork oil capacity and compression/rebound damping following the instructions below.

SYMPTOM	SECTION	ADJUSTMENT PROCEDURE
Feels too hard overall	<ul style="list-style-type: none"> • Jump • Large bumps • Series of medium bumps 	<ol style="list-style-type: none"> 1. Adjust both the compression and rebound damping to a softer setting. 2. Decrease fork oil capacity. 3. Replace the spring with an optional softer one.
Feels too soft overall and bottoms	<ul style="list-style-type: none"> • Jump • Large bump • When braking 	<ol style="list-style-type: none"> 1. Adjust the compression damping to a stiffer setting. 2. Increase fork oil capacity. 3. Replace the spring with an optional stiffer one.
Feels too hard near end of travel	<ul style="list-style-type: none"> • Jump 	<ol style="list-style-type: none"> 1. Decrease fork oil capacity.
Feels too soft near end of travel and bottoms harshly	<ul style="list-style-type: none"> • Jump • Large bump 	<ol style="list-style-type: none"> 1. Adjust the compression damping to a stiffer setting. 2. Increase fork oil capacity.
Feels too hard in the beginning of stroke	<ul style="list-style-type: none"> • Jump • Large bump • Series of medium bumps • Series of small bumps 	<ol style="list-style-type: none"> 1. Adjust the compression damping to a softer setting. 2. Replace the spring with an optional softer one.
Feels too soft and unstable	<ul style="list-style-type: none"> • Series of medium bumps • Series of small bumps 	<ol style="list-style-type: none"> 1. Adjust the compression and rebound damping to a stiffer setting.
Bounces	<ul style="list-style-type: none"> • Jump • Large bump 	<ol style="list-style-type: none"> 1. Adjust the rebound damping to a stiffer setting.
Bounces	<ul style="list-style-type: none"> • Series of small bumps 	<ol style="list-style-type: none"> 1. Adjust the rebound damping to a softer setting.

NOTE:

When adjusting the front fork oil level, make sure that the oil level is within the specified range. Also, the oil level should be increased or decreased by not more than 3 mm (Approx. 2.6 ml) at a time.

When adjusting the damping setting, attempt turning the adjuster 1 to 2 click (or 1/4 turn) at a time for each adjustment.

REAR SUSPENSION TUNING

REAR SUSPENSION

The rear suspension compression and rebound damping force, and spring pre-load are adjustable for rider's preference, rider's weight and course condition.

NOTE:

Break-in the rear suspension when riding with a new rear cushion unit.

COMPRESSION DAMPING FORCE ADJUSTMENT

Fully turn the damping force adjuster ① clockwise. It is at stiffest position and turn it out to standard setting.

NOTE:

Do not force the adjuster screw past the stopped position or the adjuster may be damaged.

DATA Standard setting: 3/4 turns out from stiffest position

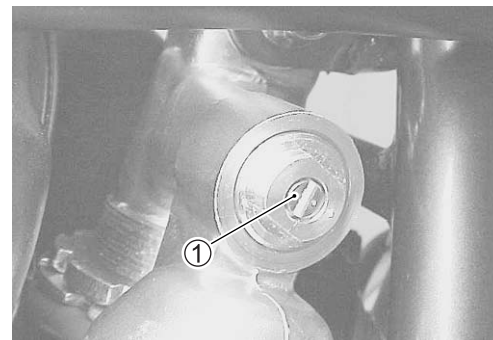

REBOUND DAMPING FORCE ADJUSTMENT

Fully turn the damping force adjuster ② clockwise. It is at stiffest position and turn it out to standard setting.

NOTE:

Do not force the adjuster screw past the stopped position or the adjuster may be damaged.

DATA Standard setting: 2 turns out from stiffest position



SPRING PRE-LOAD ADJUSTMENT

- Remove the seat frame covers and frame side tube.
- Remove the cleaner box.
- Loosen the lock-nut ①.
- Turn the adjuster ② clockwise or counterclockwise to change the spring pre-load.
- Tighten the lock-nut ①.

DATA Standard spring set length: 3.1 mm (0.12 in)
compressed from spring free length (RM85)
Standard spring set length: 4.8 mm (0.19 in)
compressed from spring free length (RM85L)

DATA Spring set length adjustable range:
2 – 12 mm (0.08 – 0.47 in)
compressed from spring free length

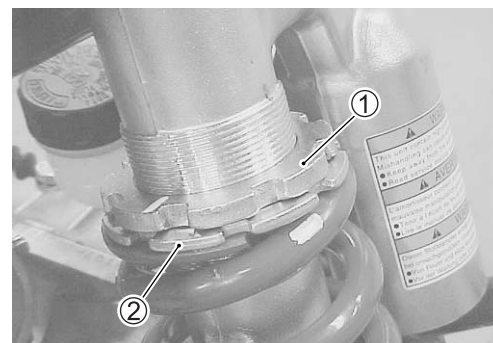

NOTE:

Turning the adjuster ② without loosening the lock-nut ① can damage the rear cushion unit.

- To remount the rear frame assembly reverse the sequence as described.

REAR SUSPENSION TUNING PROCEDURE

- Adjust the rear suspension according to the rider's weight and preference by referring to the table below.
(Spring replacement  17-4)

Spring	Spring rate	Part No./Marking paint
Soft (Option)	44 N/mm (4.4 kgf/mm) RM85	62211-03B80/GREEN (2 line)
	46 N/mm (4.6 kgf/mm) RM85L	62211-03B90/GREEN
Standard	46 N/mm (4.6 kgf/mm) RM85	62211-03B90/GREEN
	48 N/mm (4.8 kgf/mm) RM85L	62211-03BA0/BLACK
Hard (Option)	48 N/mm (4.8 kgf/mm) RM85	62211-03BA0/BLACK
	50 N/mm (5.0 kgf/mm) RM85L	62211-03BB0/RED

- Measure the distance L1 from the seat bolt to the chain adjuster lock-nut with the motorcycle on the stand and the rear wheel lifted off the ground.
- Measure the distance L2 from the seat bolt to the chain adjuster lock-nut with the motorcycle off the stand and riding the motorcycle normally in full riding gear.
- Find the sag by subtracting L2 from L1. Standard sag range is 85 – 95 mm (3.3 – 3.7 in).

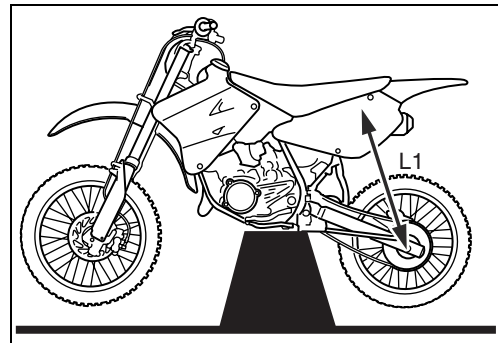

When the sag measured is:	Adjustment procedure
Less than 85 mm (3.3 in)	Increase spring pre-set length by turning the spring adjuster nut.
More than 95 mm (3.7 in)	Reduce spring pre-set length by turning the spring adjuster nut.

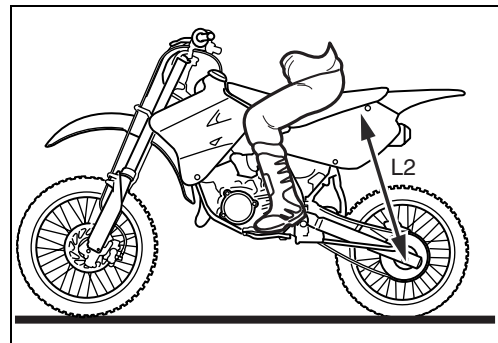
**REAR SUSPENSION**

After the sag measurement has been set between 85 mm (3.3 in) to 95 mm (3.7 in), test ride the motorcycle and adjust the suspension for the rider and track conditions referring to the guide below.

SYMPTOM	SECTION	ADJUSTMENT PROCEDURE
Bottoms	<ul style="list-style-type: none"> • Jump • Large bump 	<ol style="list-style-type: none"> 1. Adjust the compression damping to a harder (H) setting. (See note below.) 2. Adjust the sag to a smaller measurement. (closer to 85 mm) 3. Replace the spring with an optional stiffer one.
Kicks up	<ul style="list-style-type: none"> • Medium to large bumps • Small to medium bumps • Decelerating or braking 	<ol style="list-style-type: none"> 1. Adjust the rebound damping to a harder (H) setting. (See note below.) 2. Adjust the sag to a larger measurement. (closer to 95 mm) 3. Replace the spring with an optional softer one.
Hits bumps too harshly	<ul style="list-style-type: none"> • Jump • Large bump • Series of medium bumps 	<ol style="list-style-type: none"> 1. Adjust the compression damping to a softer (S) setting. (See note below.) 2. Adjust the sag to a larger measurement. (closer to 95 mm) 3. Replace the spring with an optional softer one.
Feels harsh and tends to sink	<ul style="list-style-type: none"> • Series of medium bumps • Series of small bumps 	<ol style="list-style-type: none"> 1. Adjust the rebound damping to a softer (S) setting. (See note below.)
Feels too soft and unstable	<ul style="list-style-type: none"> • Series of medium bumps • Series of small bumps 	<ol style="list-style-type: none"> 1. Adjust the rebound damping to a harder (H) setting.
Provides poor traction	<ul style="list-style-type: none"> • Accelerating • Series of small bumps 	<ol style="list-style-type: none"> 1. Adjust the compression and rebound damping to a softer setting, one at a time alternatively until the optimum settings are obtained. 2. Replace the spring with an optional softer one.

NOTE:

When adjusting the damping setting, attempt turning the adjuster 1/4 to 1/2 turn at a time for each adjustment.

SUSPENSION BALANCE

Balancing the front to rear suspension properly is the most critical adjustment for suspension performance. If the front forks are adjusted harder than the rear suspension, such as changing to heavier front fork oil, stiffer compression and rebound setting, air pressure build up in the forks and so on, the front forks will collapse less on bumps. This transfers more of the motorcycle and rider weight rearward, possibly causing the rear suspension to bottom, where as it felt fine before the front fork adjustment was made.

BALANCE TEST

Stand next to the motorcycle on level ground. Place one foot on the foot rest closest to you. Sharply push down. The front and rear suspensions should both collapse equally.

BALANCING TIPS

- Check for air pressure build-up in front forks. Heat and altitude will increase air pressure in the front forks.
- Always stay within sag measurement limits, 85 – 95 mm (3.3 – 3.7 in), when using spring pre-set to stiffen or soften rear suspension. If this is not possible, the next stiffer or softer accessory spring is needed.
- The rear shock compression damping can be used to fine tune suspension balance and is easy to access.

ENGINE REMOVAL AND INSTALLATION

CONTENTS

<i>ENGINE REMOVAL AND INSTALLATION</i>	<i>5- 2</i>
<i>REMOVAL</i>	<i>5- 2</i>
<i>INSTALLATION</i>	<i>5- 5</i>

ENGINE REMOVAL AND INSTALLATION

REMOVAL

- Remove the frame covers ① (left & right) and seat ②.
- Remove the clamps ③.
- Turn the fuel valve lever to the “OFF” position and disconnect the fuel hose.
- Remove the radiator cover ④.
- Remove the fuel tank mounting bolts ⑤, left and right.
- Remove the fuel tank by unhooking the band ⑥ from the hooked part.
- Drain transmission oil. (☞ 2-7)
- Drain engine coolant. (☞ 12-3)

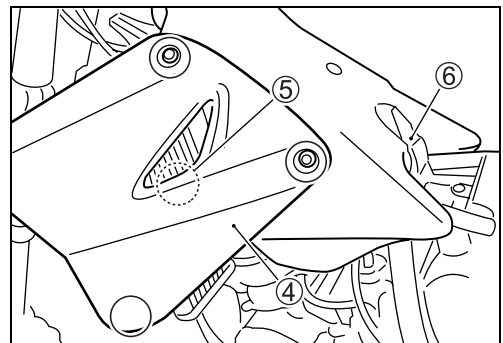
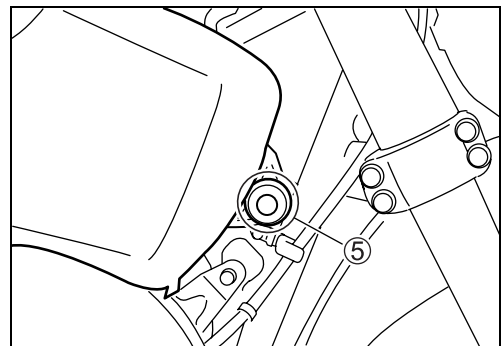
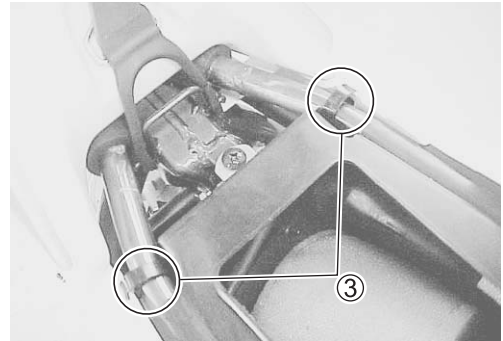
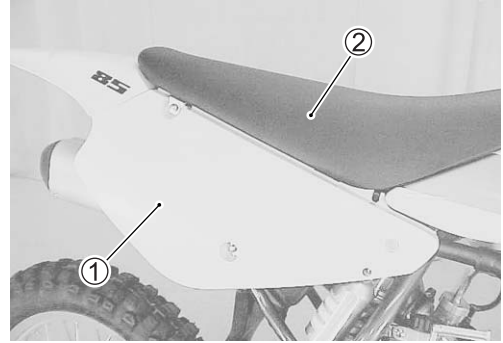

- Remove the exhaust pipe fitting springs with the special tool.

 09920-20310: Spring hook

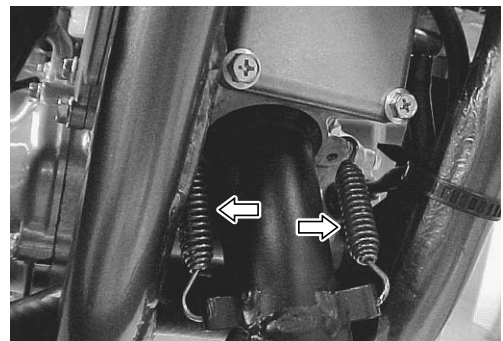

- Remove the muffler mounting bolts.
- Remove the exhaust pipe and muffler.



- Remove the exhaust pipe and gasket.

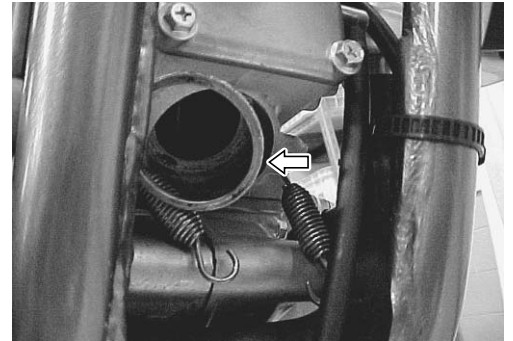

- Disconnect the radiator hose ①.

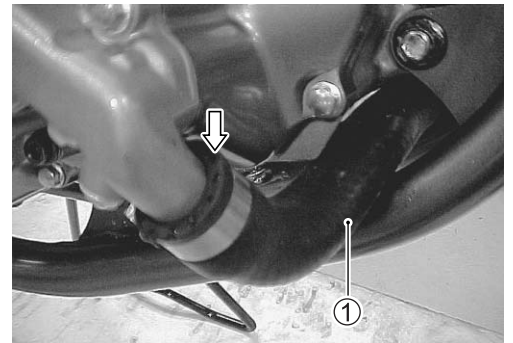

- Disconnect the radiator hose ②.
- Remove the spark plug cap ③ and spark plug ④.
- Disconnect the magneto lead wire coupler ⑤.

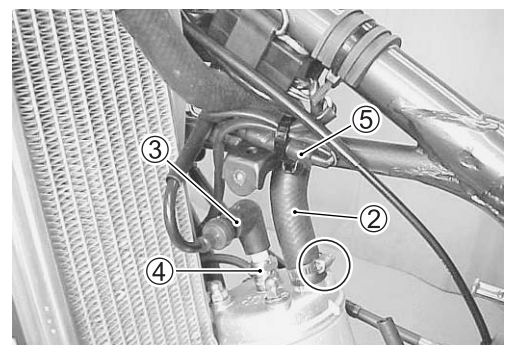

- Remove the lead wire/hose clamp.

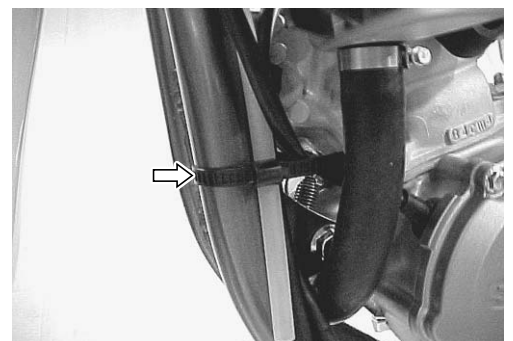

- Loosen the carburetor clamp screws and remove the carburetor.

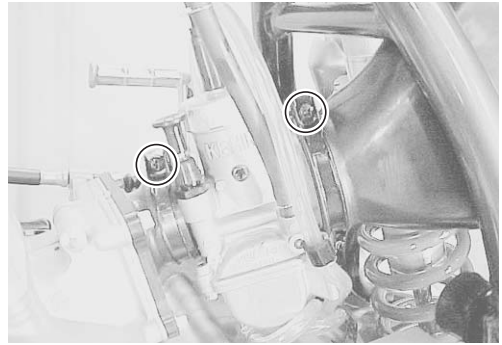

- Remove the magneto cover.

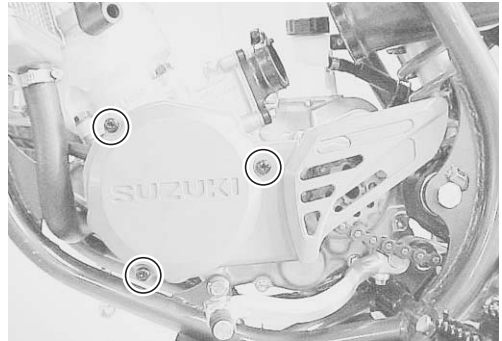

- Remove the drive chain.

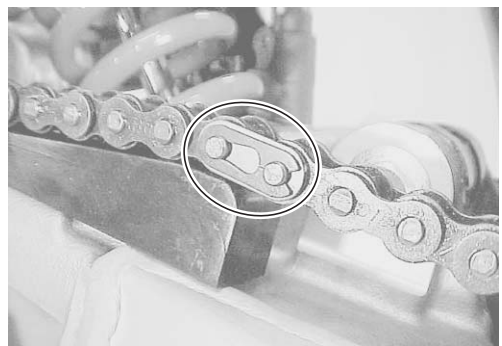

- Remove the clutch release arm ① and disconnect the clutch cable.



- Remove the engine mounting bolts.

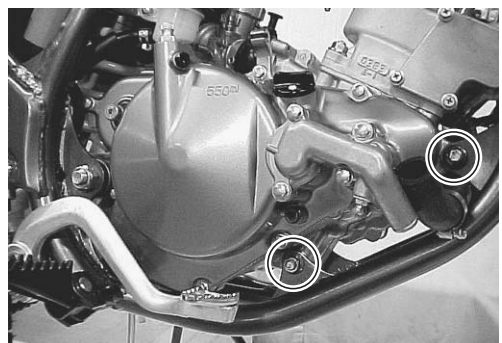

- Loosen the swingarm pivot nut.

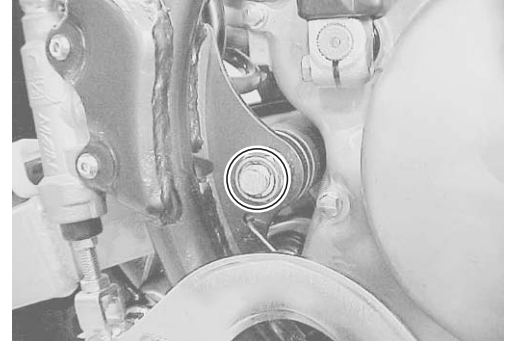

- Extract three quarters of the swingarm pivot shaft so as to keep the swingarm in position.

NOTE:

The swingarm will come off when the swingarm pivot shaft is completely removed.

- Remove the engine from the frame.

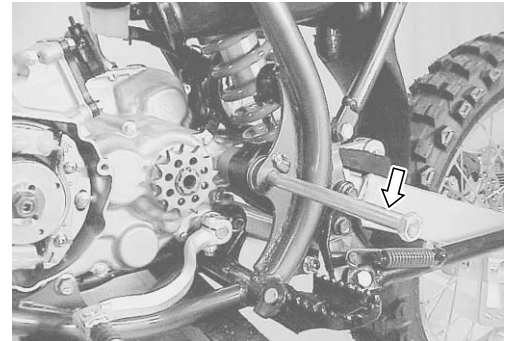

INSTALLATION

- Fit the swingarm in its position and hold it with the swingarm pivot shaft.
- Mount the engine on the frame.
- Tighten the engine mounting nuts.

Tightening torque

	N·m	kgf-m	lb-ft
①	58	5.8	42.0
②	43	4.3	31.0
③	45	4.5	32.5

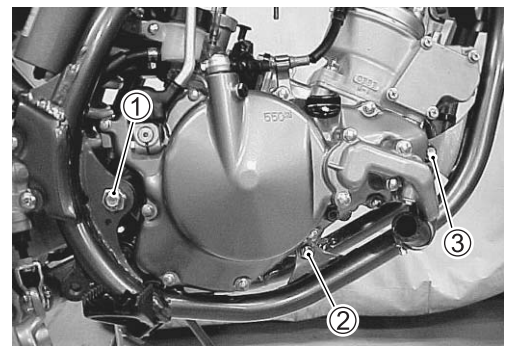

NOTE:

Replace the self-locking nuts with new ones.

- Reassemble the removed parts in the reverse order of removal.

NOTE:

Route the cables and lead wires correctly. (↪ 18-15 and -16)

- Reassemble the drive chain clip so the slit end faces opposite the direction of rotation.

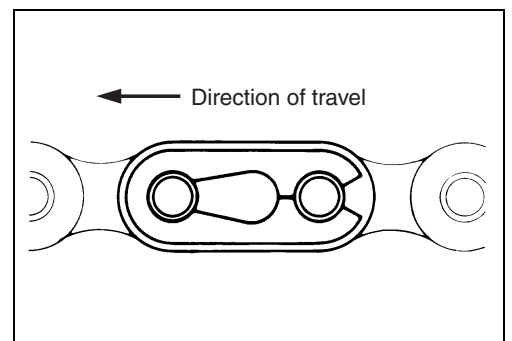

- Fit the projection of the carburetor to the depression on intake pipe.

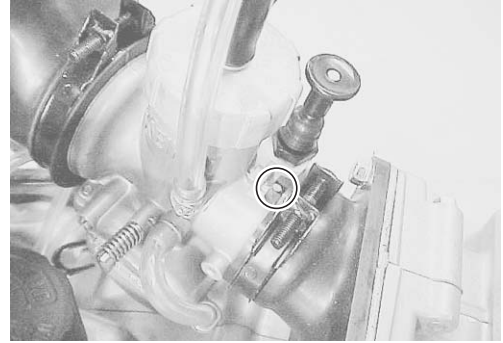

- Apply a small quantity of engine oil to the exhaust pipe O-ring.

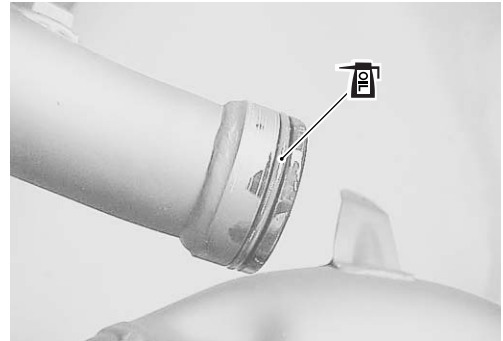

- Install the exhaust gasket and exhaust pipe.

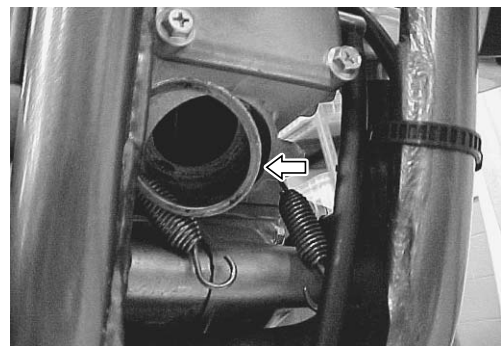

After mounting the engine, inspect the following items.

- Transmission oil level (☞ 2-7)
- Engine coolant level (☞ 2-8)
- Throttle cable play (☞ 2-10)
- Clutch lever play (☞ 2-9)
- Drive chain slack (☞ 2-13)

CYLINDER, PISTON AND EXHAUST VALVE

CONTENTS

CONSTRUCTION	6- 2
CYLINDER, PISTON AND EXHAUST VALVE	6- 2
ENGINE TOP END	6- 3
CYLINDER HEAD REMOVAL	6- 3
CYLINDER REMOVAL	6- 3
PISTON REMOVAL	6- 4
EXHAUST VALVE REMOVAL	6- 4
CYLINDER HEAD INSPECTION	6- 5
CYLINDER INSPECTION	6- 5
PISTON AND PISTON RING INSPECTION	6- 6
EXHAUST VALVE INSPECTION	6- 7
CONROD INSPECTION	6- 8
PISTON RING AND PISTON REASSEMBLY	6- 8
EXHAUST VALVE REASSEMBLY	6- 8
CYLINDER REASSEMBLY	6-10
EXHAUST VALVE GOVERNOR REMOVAL AND DISASSEMBLY	6-12
EXHAUST VALVE GOVERNOR INSPECTION	6-13
EXHAUST VALVE GOVERNOR REASSEMBLY AND INSTALLATION	6-14

CONSTRUCTION CYLINDER, PISTON AND EXHAUST VALVE

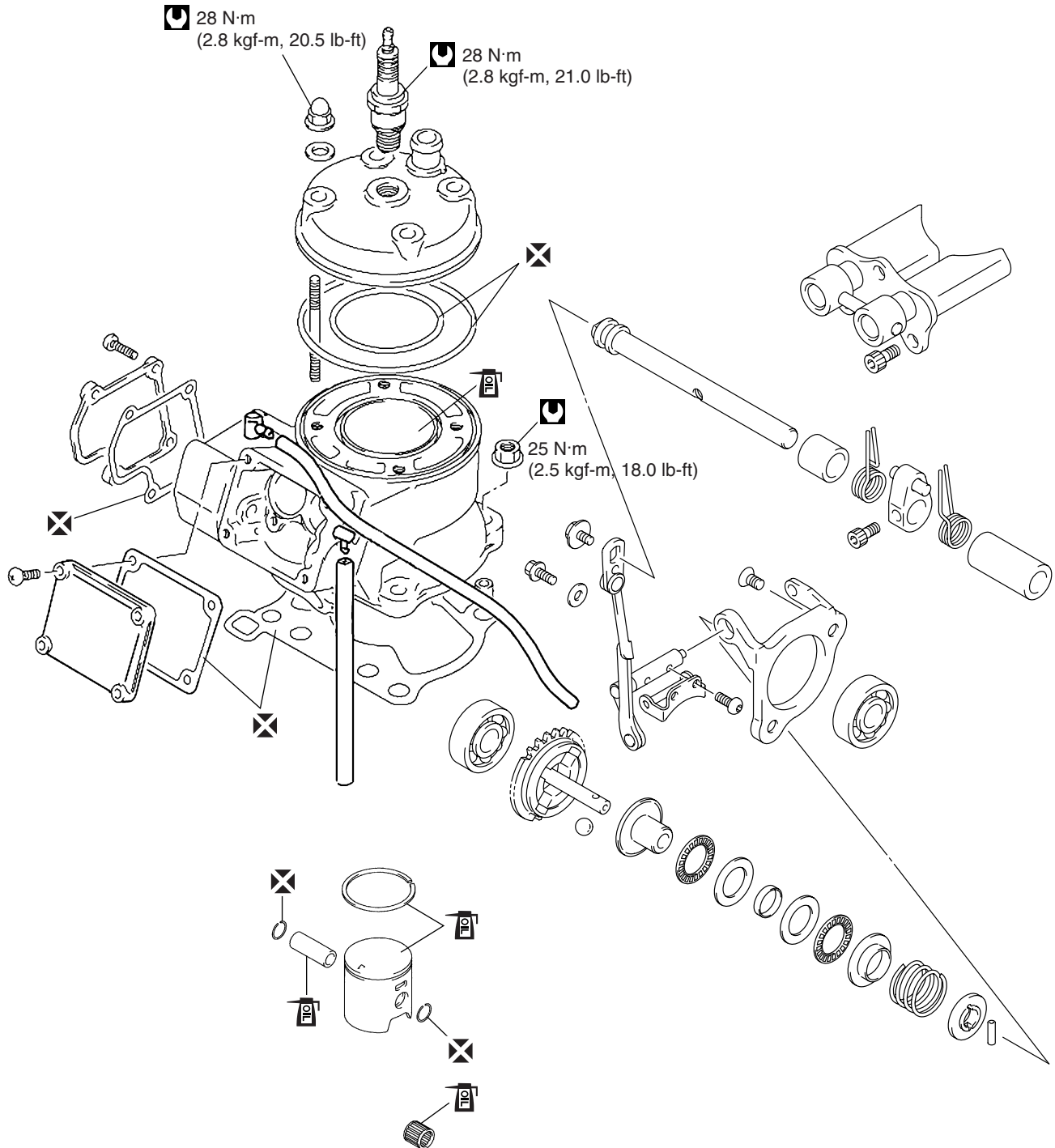

ENGINE TOP END

CYLINDER HEAD REMOVAL

- Remove the frame covers and seat. (☞ 5-2)
- Remove the radiator covers and fuel tank. (☞ 5-2)
- Remove the muffler. (☞ 5-2)
- Drain engine coolant. (☞ 12-3)
- Loosen the clamp and disconnect the radiator hose ①.
- Remove the spark plug cap ② and spark plug ③.

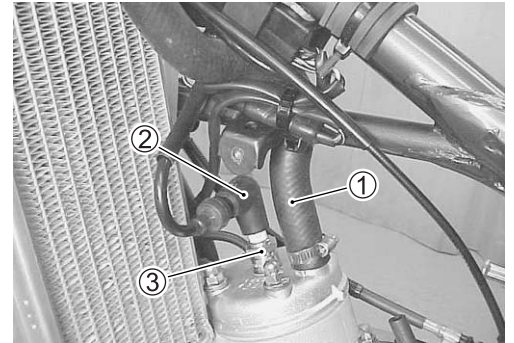

- Remove the cylinder head ④.

NOTE:

Loosen the cylinder head nuts diagonally to prevent cylinder head distortion.



CYLINDER REMOVAL

- Remove the cylinder head. (☞ above)
- Remove the exhaust pipe. (☞ 5-2)
- Remove the cylinder head O-rings ① and ②.
- Remove the exhaust valve rod cover ③ and gasket.

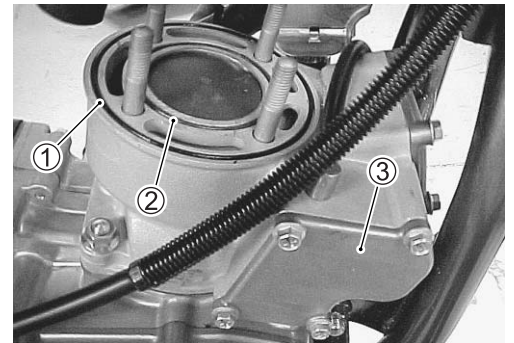

- Remove the bolt ④ and disconnect the exhaust valve rod.

CAUTION

Set the pin (A), provided with machine, to the lever before loosening the bolt ④. Loosening the bolt without setting the pin can damage the valve shaft arm spring.

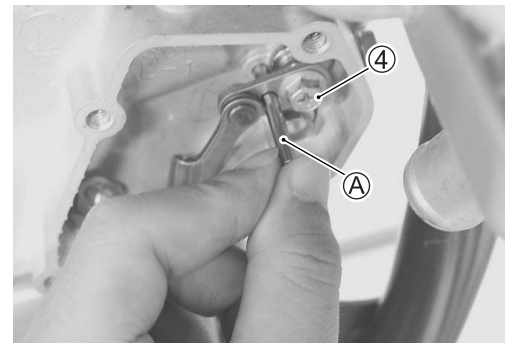

- Loosen the four cylinder nuts ①.
- Remove the cylinder ②.

NOTE:

Loosen the cylinder nuts diagonally.

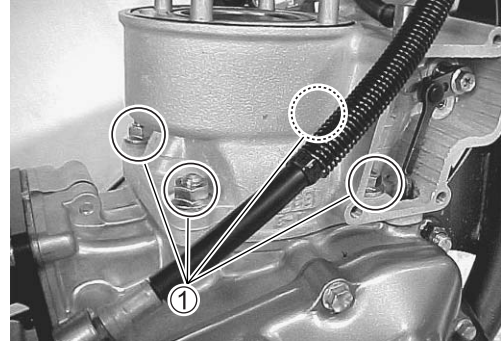

- Remove the gasket ③ and dowel pins ④.

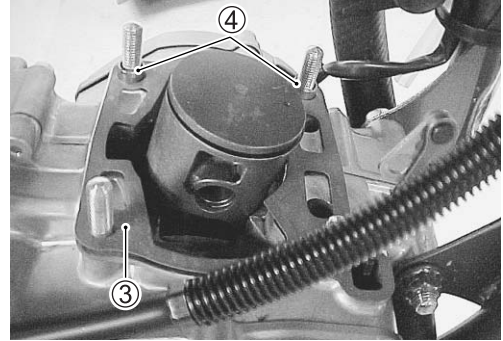

PISTON REMOVAL

- Remove the cylinder head and cylinder. (☞ 6-3)
- Remove the piston pin circlip ①.

NOTE:

Place cloth on the crankcase to prevent the piston pin circlip from dropping into the crankcase chamber.

- Remove the piston pin ②.
- Remove the piston ③.
- Remove the conrod small end bearing ④.
- Remove the piston ring.

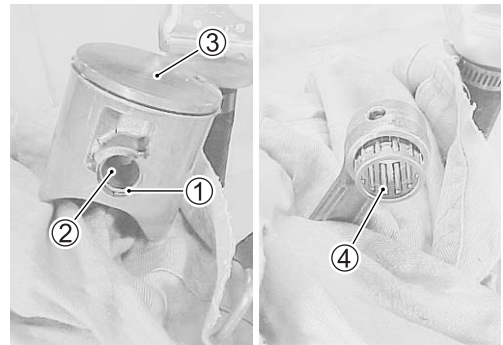

EXHAUST VALVE REMOVAL

- Remove the cylinder head and cylinder. (☞ 6-3)
- Remove the breather hoses.
- Remove the exhaust valve cover ①.

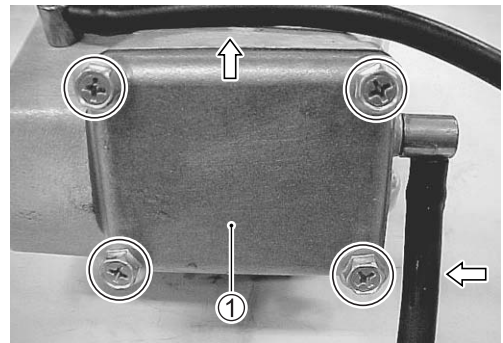

- Remove the exhaust valve shaft stop retainer ②.

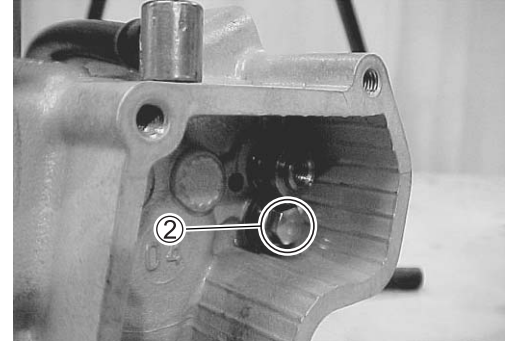

- Loosen the bolt ③. Draw out the shaft.
- Remove the spacers ④, springs ⑤ and valve shaft arm ⑥.

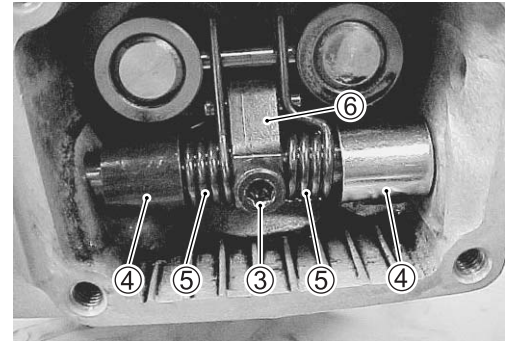

- Remove the exhaust valve assembly ⑦.

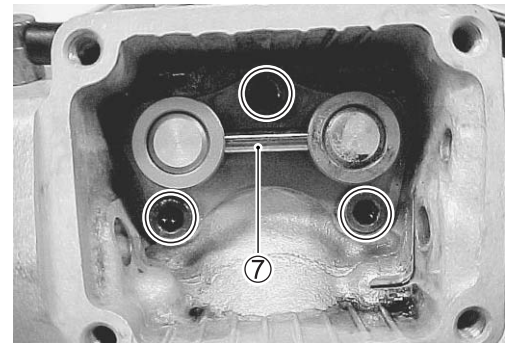

CYLINDER HEAD INSPECTION

- Remove carbon deposits from the cylinder head.
- Inspect the cylinder head for cracks around the spark plug hole.
- Inspect for cylinder head distortion.

DATA Cylinder head distortion
Service Limit: 0.05 mm (0.002 in)

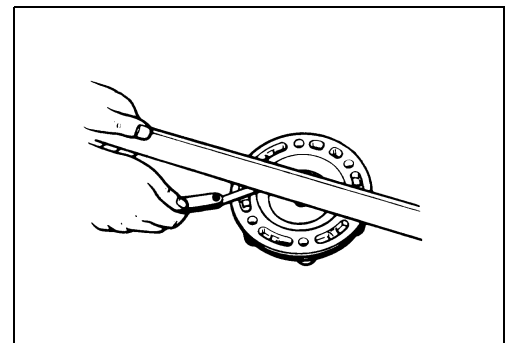

CYLINDER INSPECTION

- Remove carbon deposits from the exhaust port.
- Inspect the cylinder for cracks and replace the cylinder, if necessary.
- Inspect the cylinder bore for wear, nicks and scratches.

NOTE:

Chrome-plated cylinder bore can not be modified such as boring and honing.

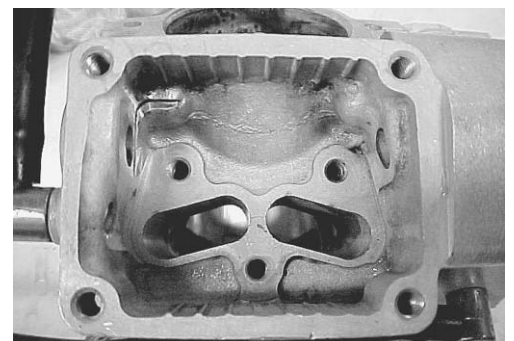

- Inspect for cylinder distortion.

DATA **Cylinder distortion**
Service Limit: 0.05 mm (0.002 in)

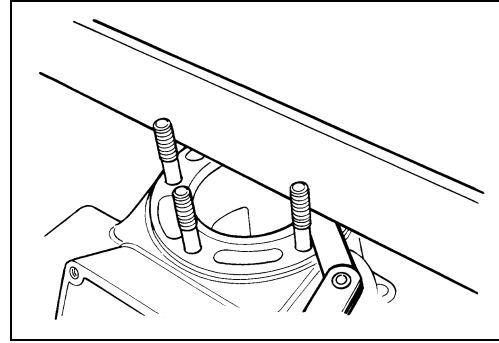

- Measure the cylinder bore for wear with a cylinder gauge 15 mm (0.59 in) from the top surface.

NOTE:

The cylinder bore must be measured perpendicular to the crankshaft axis direction.

DATA **Cylinder bore**
Standard: 48.000 – 48.015 mm (1.8898 – 1.8904 in)

TOOL 09900-20508: Cylinder gauge set (40 – 80 mm)

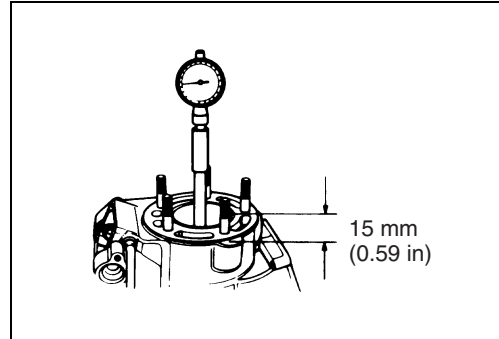

PISTON AND PISTON RING INSPECTION

- Remove the piston ring from the piston ring groove.
- Remove carbon deposits from the piston.
- Inspect the piston for wear, scratches and damage.
- Measure the piston outer diameter 16 mm (0.63 in) from the skirt end.

DATA **Piston outer diameter**
Service Limit: 47.880 mm (1.8850 in)

TOOL 09900-20202: Micrometer (25 – 50 mm)

- Measure the piston pin bore and piston pin diameter.

DATA	Service Limit
Piston pin bore	14.030 mm (0.5524 in)
Piston pin O.D.	13.980 mm (0.5504 in)

TOOL 09900-20605: Dial gauge
 09900-20205: Micrometer (0 – 25 mm)

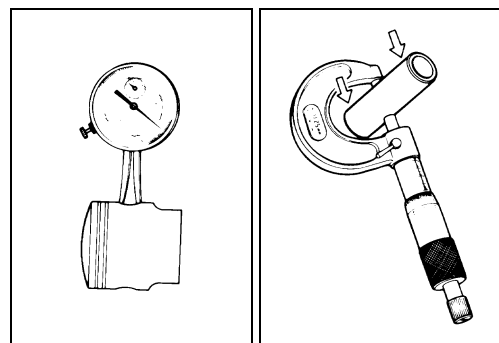
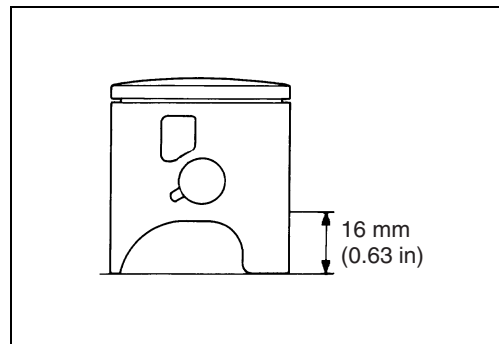

- Remove carbon deposits from piston ring and piston ring groove.
- Fit the piston ring into the ring groove and measure the clearance with a thickness gauge.

DATA **Piston ring to groove clearance**
Standard: 0.020 – 0.060 mm (0.0008 – 0.0024 in)

TOOL 09900-20803: Thickness gauge

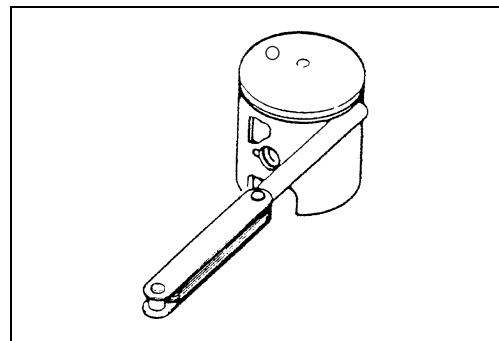

- Fit the piston ring into the cylinder and measure the piston ring end gap with a thickness gauge.

DATA Piston ring end gap
Service Limit: 0.80 mm (0.031 in)

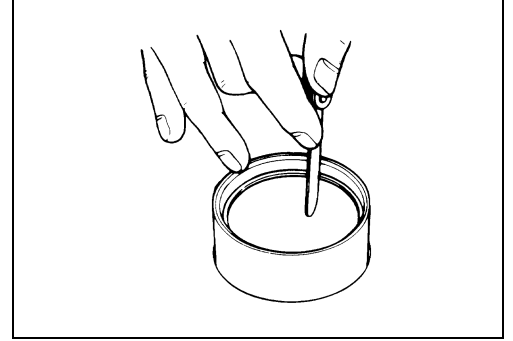

- Measure the piston ring free end gap.

DATA Piston ring free end gap
Service Limit: 3.2 mm (0.13 in)

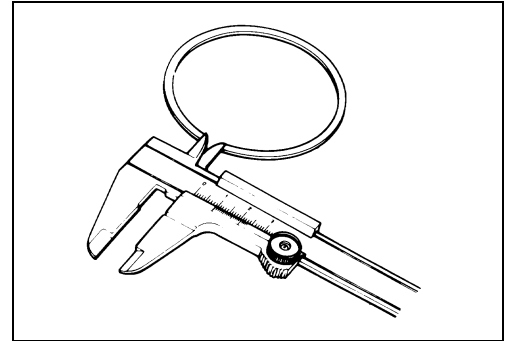

EXHAUST VALVE INSPECTION

- Remove carbon deposits from the exhaust valve and valve guide.
- Inspect the exhaust valve and valve guide for wear and scratches.

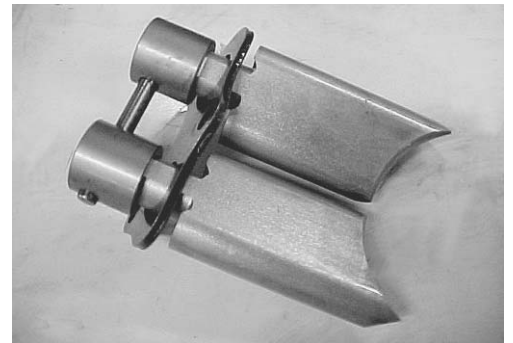

- Inspect the exhaust valve shaft and arm for damage.



- Inspect the exhaust valve breather hoses for clogging with tar. If clogging is found, clean up it.

NOTE:

Using several brands of engine oil may cause tar to drip from the breather hoses.

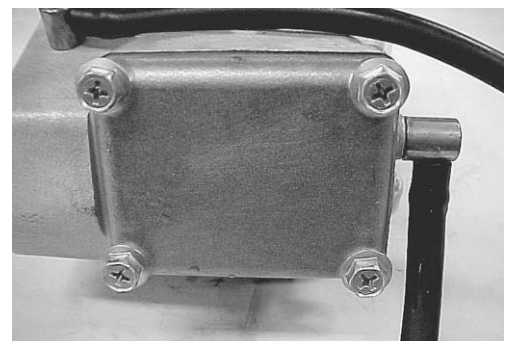

CONROD INSPECTION

- Measure the conrod small end bore.

DATA Conrod small end bore

Service Limit: 18.040 mm (0.7102 in)

TOOL 09900-20605: Dial gauge

- Fit the piston pin and bearing into the conrod small end and check the play.

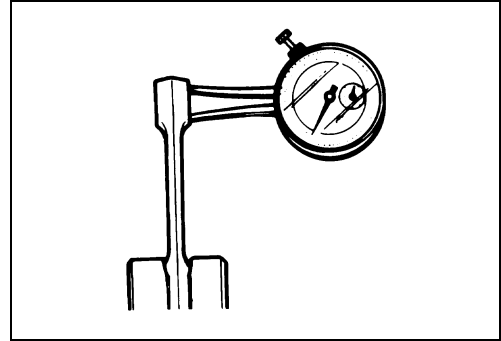

PISTON RING AND PISTON REASSEMBLY

- Apply engine oil to the piston ring and piston ring groove.
- Install the piston ring into the piston ring groove so the piston ring end comes to the piston ring locating pin.
- Apply engine oil to the piston pin and bearing.
- Install the bearing to the conrod small end.

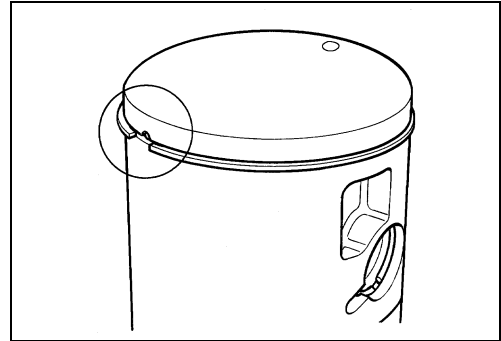

- Face the depression on the piston top to the exhaust port side and install the piston ①.
- Install the piston pin ② and piston pin circlips ③. End gap of the circlip should not be aligned with the cutaway in the piston pin bore.

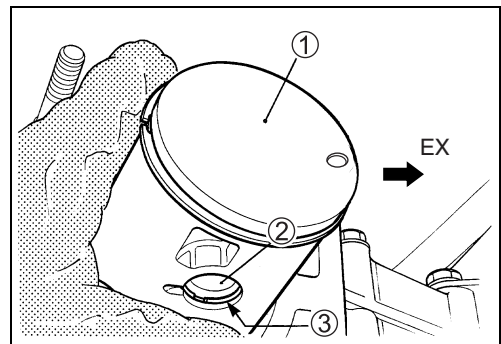

NOTE:

- * Replace the piston pin circlip with a new one.
- * Place cloth on the crankcase to prevent piston pin circlip from dropping into the crankcase chamber.

EXHAUST VALVE REASSEMBLY

- Apply engine oil to the exhaust valves.
- Assemble the exhaust valves and the exhaust valve retainer.
- Install the exhaust valves into the cylinder.

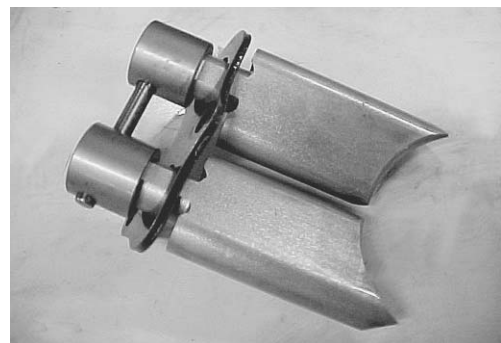

- Tighten the exhaust valve retainer bolts.

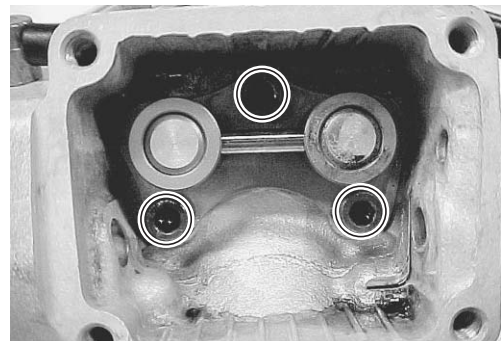

- Install the spacers ①, springs ②, valve shaft arm ④ and shaft.
- Tighten the bolt ③.

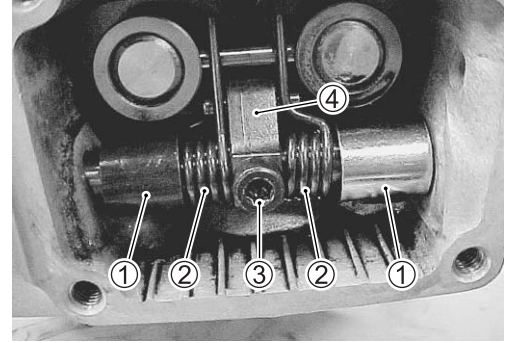

- Tighten the stopper bolt ⑤.

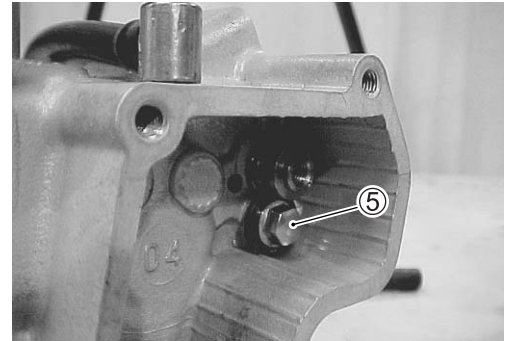

- Install the gasket and cover.

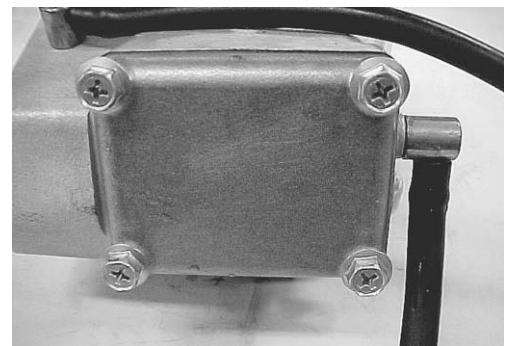

CYLINDER REASSEMBLY

- Install the new gasket. Install the dowel pins ①.
- Apply engine oil to the cylinder bore.
- Hold the piston and piston ring, and insert the piston into the cylinder.

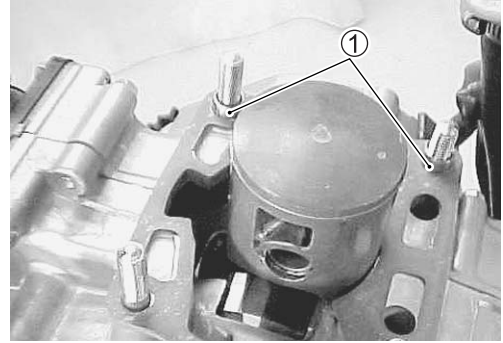

CAUTION

If the piston pin end is not at the proper position, you can not insert the piston into the cylinder properly and the piston ring will be damaged.

Locate the piston ring end to the locating pin and insert the piston into the cylinder.

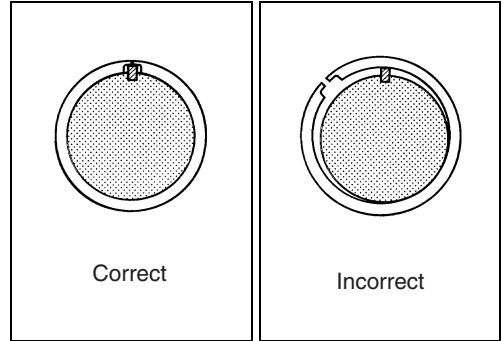

- Tighten the cylinder nuts to the specified torque according to the specified tightening order as shown.

Cylinder nut: 25 N·m (2.5 kgf-m, 18.0 lb-ft)

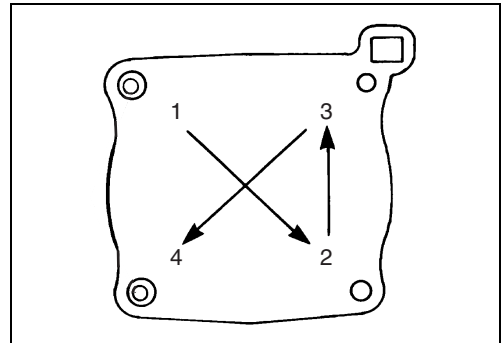

- Tighten the nut ②.

CAUTION

Set the pin ①, provided with machine, to the lever before tightening the bolt ②. Tightening the bolt without setting the pin can damage the valve shaft arm spring.

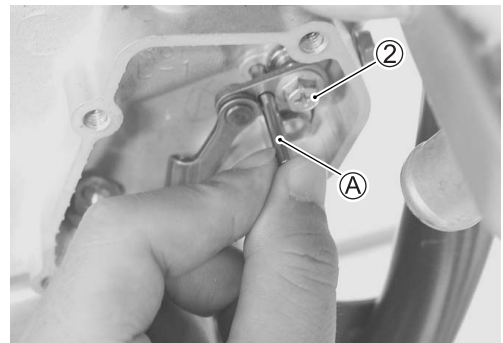

- Install the exhaust rod cover and gasket.

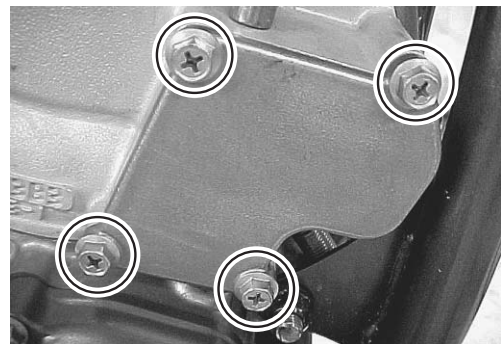

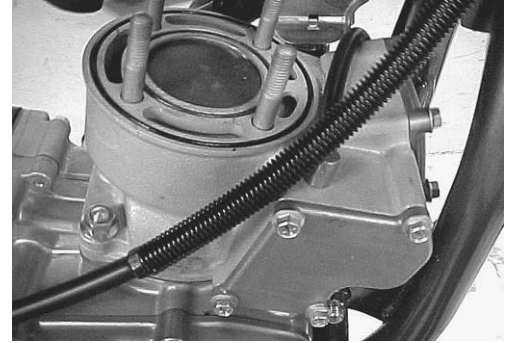

- Install the new O-rings onto the cylinder.

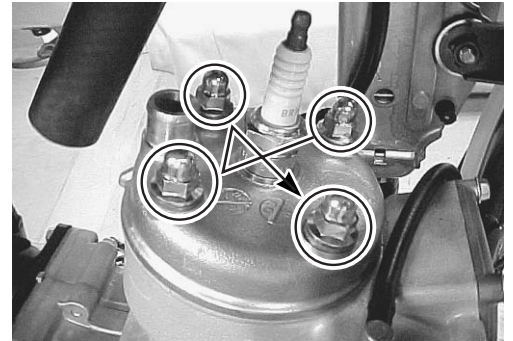

- Install the cylinder head.
- Tighten the cylinder head nuts to the specified torque according to the specified tightening order as shown.

 **Cylinder head nut: 28 N·m (2.8 kgf-m, 20.5 lb-ft)**



- Reassemble the exhaust pipe. ( 5-6)
- Reassemble the spark plug and spark plug cap.
- Connect the radiator hose and tighten the hose clamp.
- Pour engine coolant. ( 12-3)
- Inspect engine coolant leak.

EXHAUST VALVE GOVERNOR REMOVAL AND DISASSEMBLY

- Drain transmission oil. (☞ 2-7)
- Drain engine coolant. (☞ 12-3)
- Remove the exhaust pipe. (☞ 5-2)
- Remove the rear brake pedal. (☞ 15-14)
- Remove the clutch cover. (☞ 7-3)
- Remove the exhaust valve bolt. (☞ 6-4)

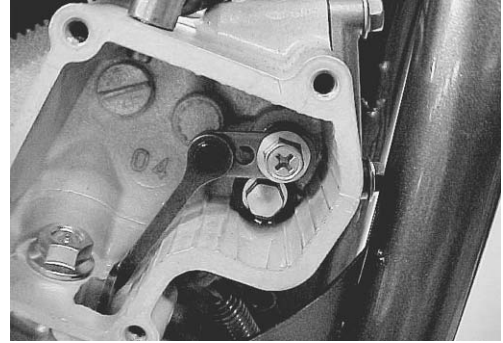

- Remove the exhaust valve governor ①.

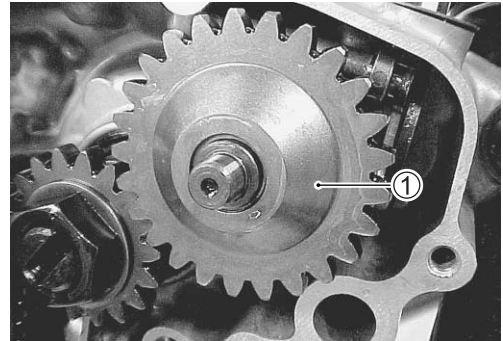

- Remove the exhaust valve actuator ②.

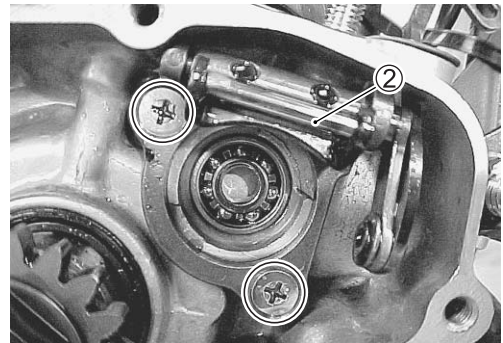

- Remove the pin ③ by pushing the retainer ④ down.

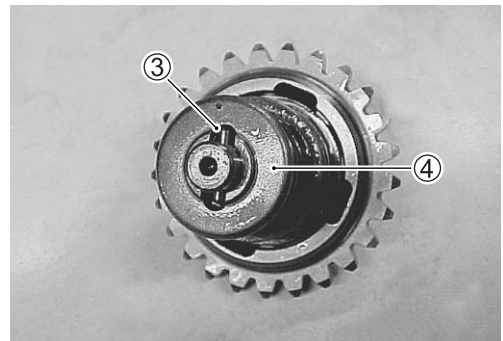

- Remove the spring ⑤, retainer ⑥ and bearing ⑦.
- Remove the washers ⑧, spacer ⑨ bearing ⑩ and stator ⑪.

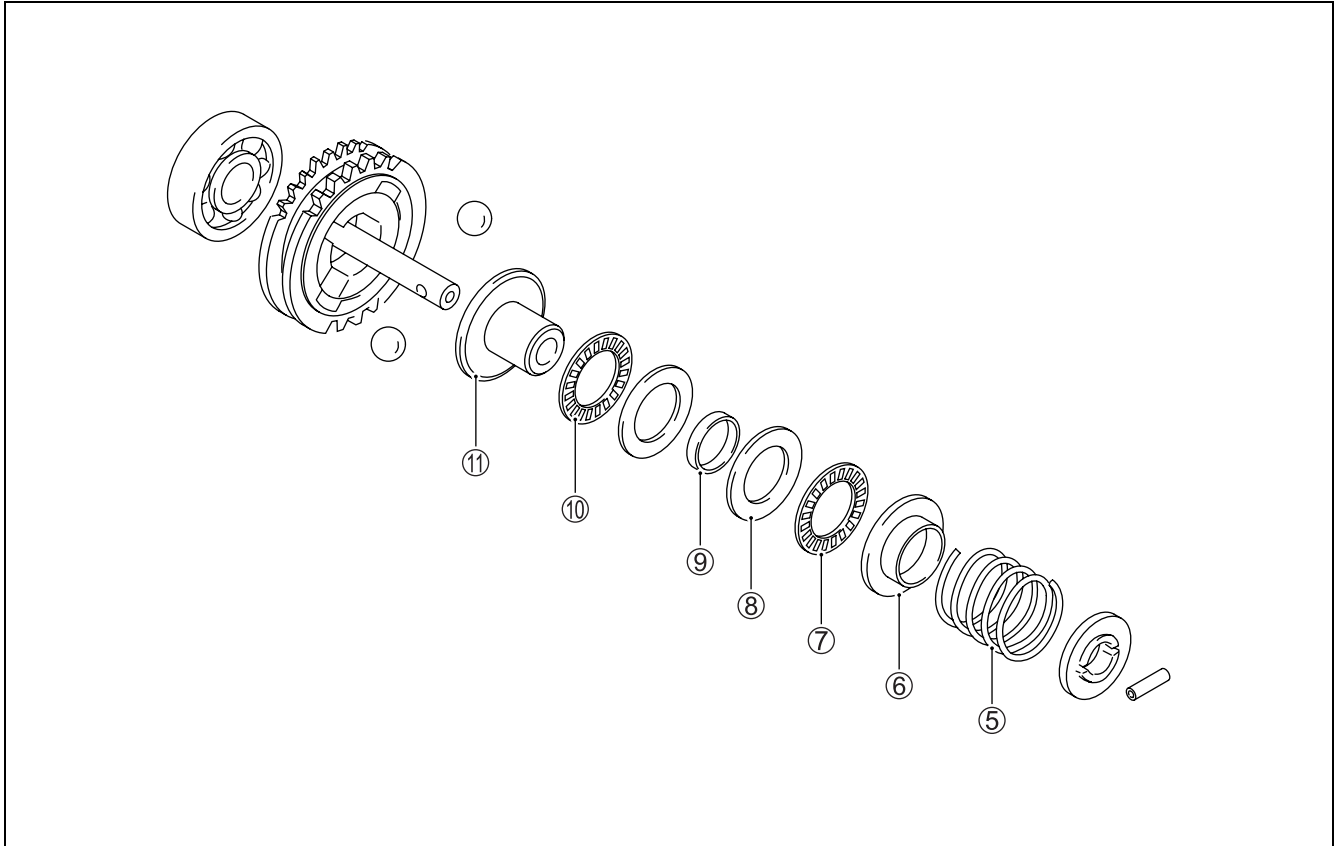

- Remove the balls ⑫.

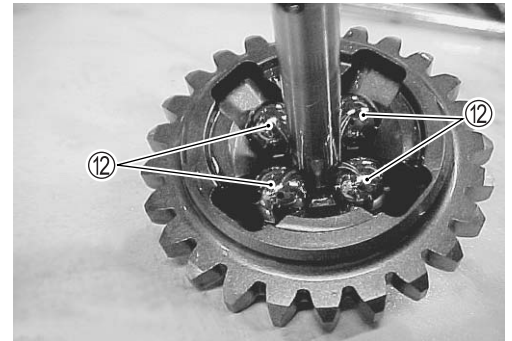

EXHAUST VALVE GOVERNOR INSPECTION

- Inspect the bearing for wear.
- Replace the bearing if there is anything unusual.



- Inspect the balls and their grooves of governor and actuator for wear or damage.
- If they are worn or damaged, replace them with the new ones.

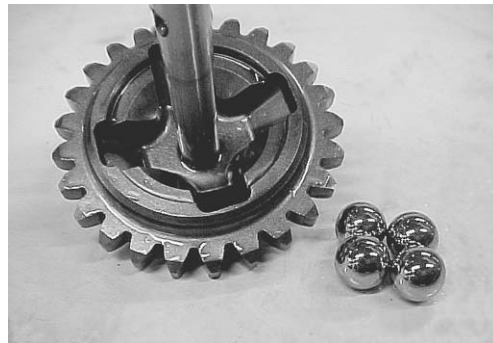

EXHAUST VALVE GOVERNOR REASSEMBLY AND INSTALLATION

Installation is in the reverse order of removal and disassembly. Pay attention to the following points:

- Apply transmission oil to the exhaust valve governor.
 - Install the exhaust valve actuator ①.
-
- Install the exhaust valve governor with the groove ① engaged with the actuator arm ②.
 - Install the actuator lever and exhaust valve rod cover. (☞ 6-10)
 - Install the brake pedal. (☞ 15-14)
 - Pour transmission oil. (☞ 2-7)
 - Pour engine coolant. (☞ 2-8)

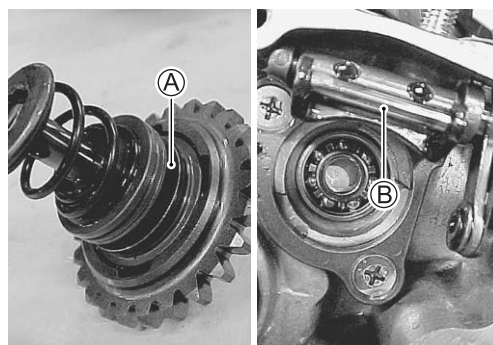
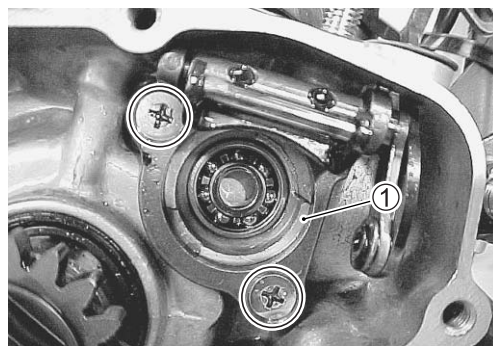

CLUTCH

CONTENTS

CONSTRUCTION	7- 2
CLUTCH	7- 2
CLUTCH	7- 3
CLUTCH PLATE REMOVAL	7- 3
CLUTCH PLATE INSPECTION	7- 3
CLUTCH SPRING INSPECTION	7- 4
CLUTCH RACK AND PINION INSPECTION	7- 4
CLUTCH PLATE REASSEMBLY	7- 4
CLUTCH SLEEVE HUB REMOVAL	7- 5
CLUTCH SLEEVE HUB INSPECTION	7- 6
CLUTCH SLEEVE HUB REASSEMBLY	7- 6

CONSTRUCTION CLUTCH

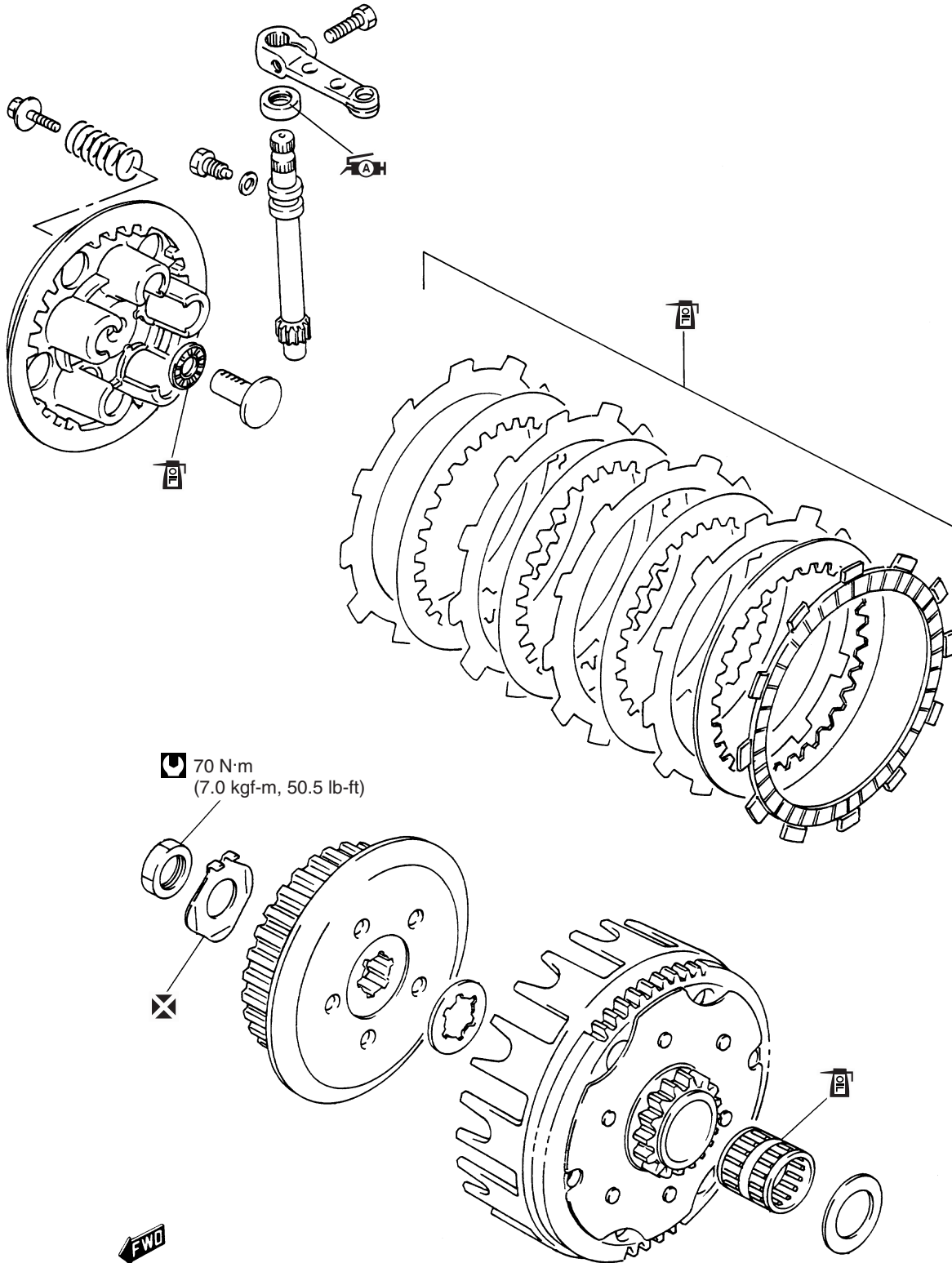

CLUTCH

CLUTCH PLATE REMOVAL

- Drain transmission oil. (☞ 2-7)
- Drain the engine coolant. (☞ 12-3)
- Remove the rear brake pedal. (☞ 15-14)
- Remove the clutch release arm ①.
- Remove the kick starter lever ②.
- Remove the clutch cover.

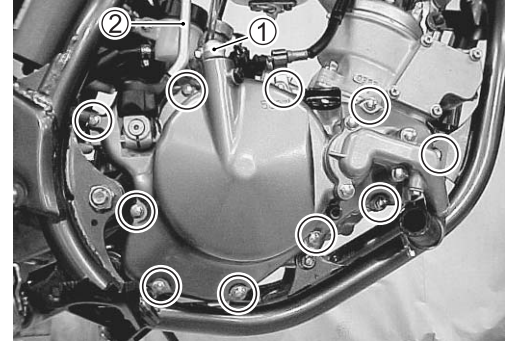

- Loosen the bolts diagonally and remove them.
- Remove the clutch springs.
- Remove the pressure plate.

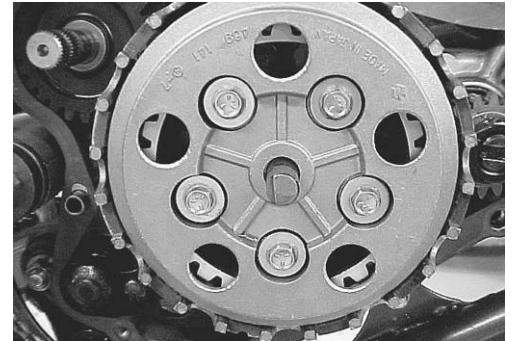

- Remove the rack ③ and bearing ④ from the pressure plate.
- Remove the drive plates and driven plates.

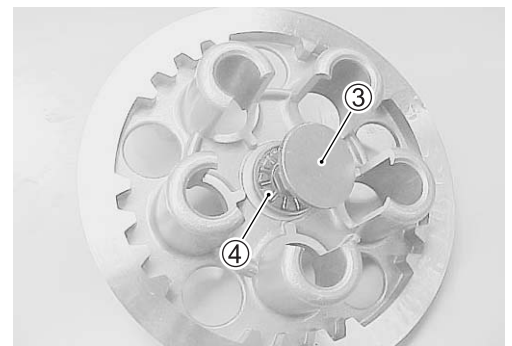

CLUTCH PLATE INSPECTION

- Measure the drive plate thickness.

DATA Drive plate thickness
Service Limit: 2.4 mm (0.094 in)

- Inspect the drive plates for wear, distortion and discoloration.

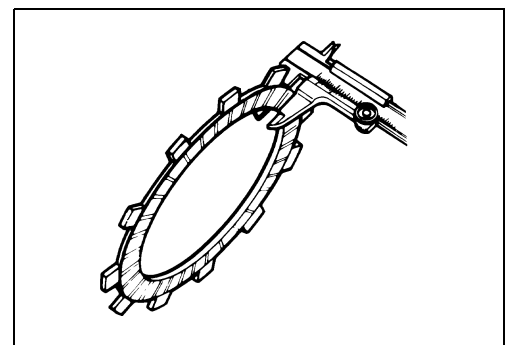

- Measure the driven plate distortion.

DATA Driven plate distortion
Service Limit: 0.10 mm (0.004 in)

- Inspect the driven plates for wear and discoloration.

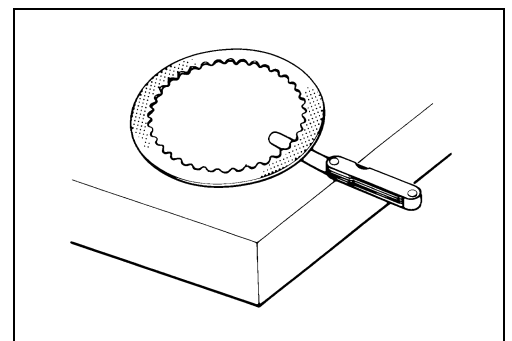

CLUTCH SPRING INSPECTION

- Measure the clutch spring free length.

DATA Clutch spring free length
Service Limit: 39.4 mm (1.55 in)

NOTE:

Replace five clutch springs together even if only one spring is exceed the service limit.

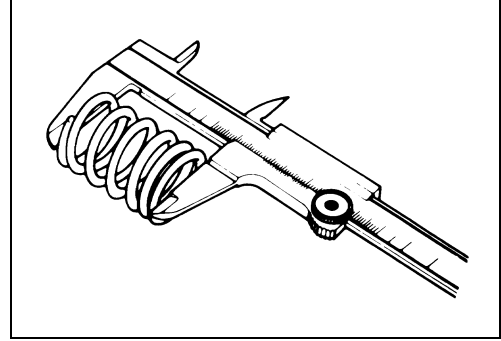

CLUTCH RACK AND PINION INSPECTION

- Inspect the clutch release rack and pinion for wear and damage.
- Inspect the clutch release arm for smooth movement and oil leakage around the oil seal.

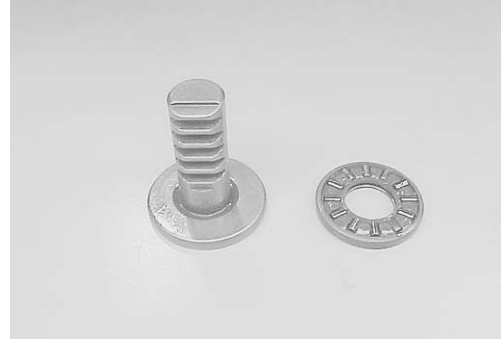

CLUTCH PLATE REASSEMBLY

- Apply transmission oil to the drive plates ① and driven plates ② and install them to the clutch sleeve hub.

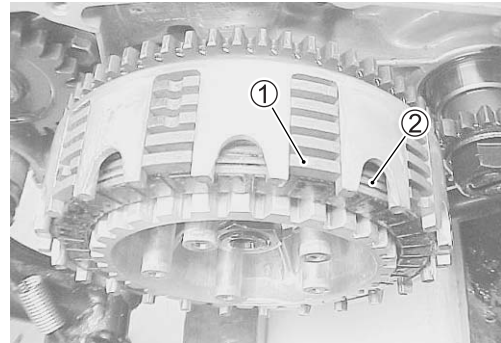

- Install the rack ③ and bearing ④.

NOTE:

The roller side of the bearing must face to the rack side.

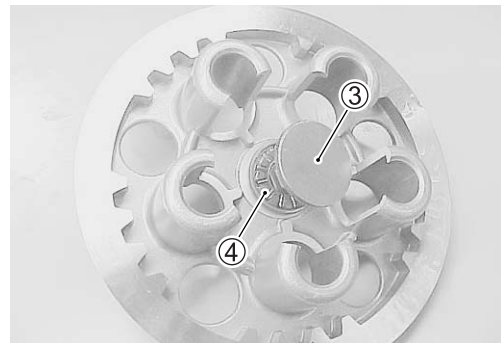

- Install the pressure plate ①.
- Install the clutch springs and bolts.
- Tighten the bolts diagonally.

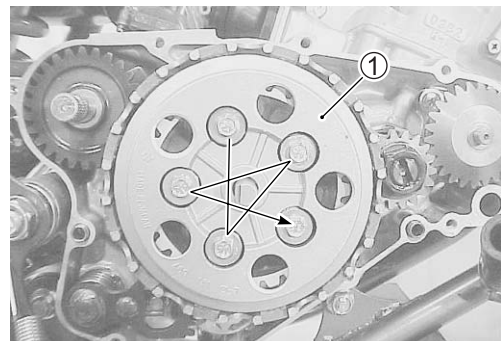

- Replace the gasket with a new one.
- Install the dowel pins.

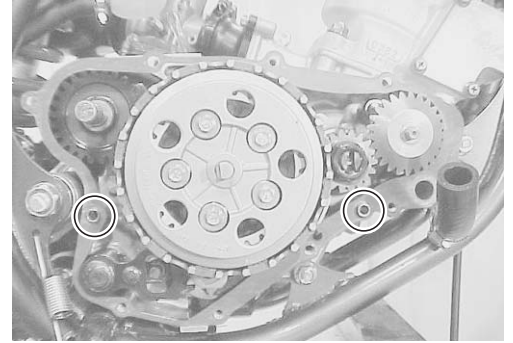

- Align the clutch release rack teeth with the pinion gear.
- Align the water pump empeller to the crankshaft end.
- Install the clutch cover.

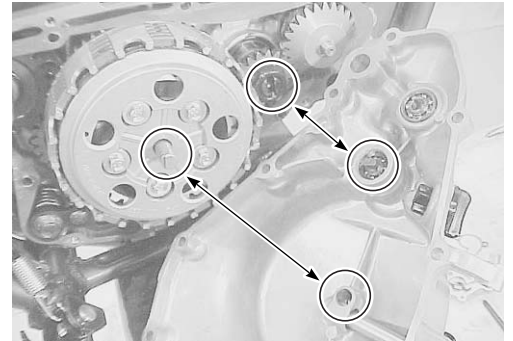

- Tighten the bolts diagonally.
- Reassemble the rear brake pedal. (☞ 15-14)
- Install the clutch release arm ①.
- Install the kick starter lever ②.
- Pour transmission oil. (☞ 2-7)
- Pour engine coolant. (☞ 2-8)
- Inspect the clutch cable play. (☞ 2-9)

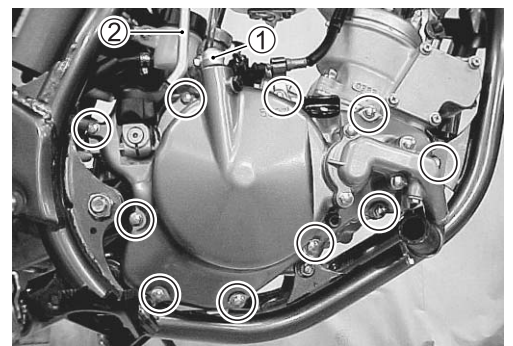

CLUTCH SLEEVE HUB REMOVAL

- Remove the pressure plate and clutch plates. (☞ 7-3)
- Flatten the lock washer ①.

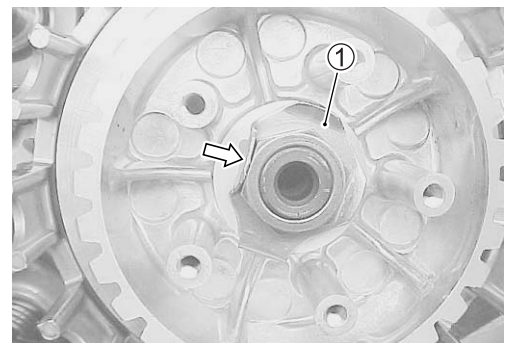

- Hold the clutch sleeve hub with the special tool and loosen the nut.

TOOL 09920-53740: Clutch sleeve hub holder

- Remove the clutch sleeve hub ②.

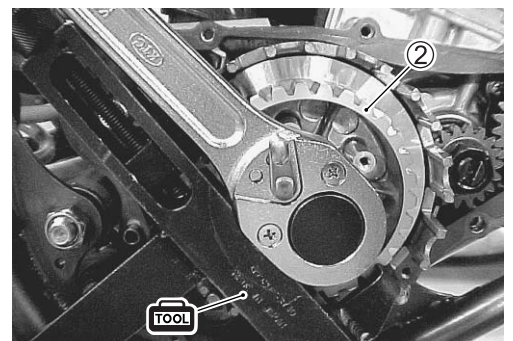

- Remove the washer ①, primary driven gear ass'y ②.

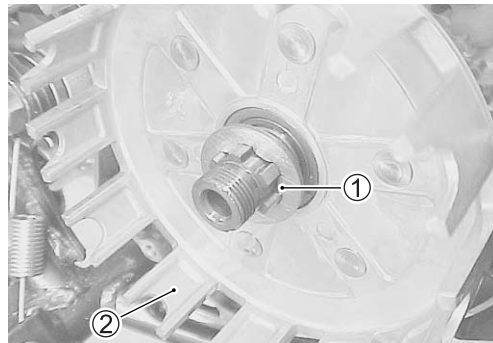

- Remove the needle bearing ③ and washer ④.
- Remove the snap ring ⑤ and kick idle gear ⑥.

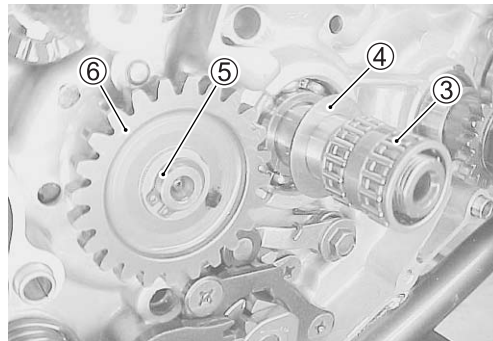

CLUTCH SLEEVE HUB INSPECTION

- Inspect the clutch sleeve hub and primary driven gear ass'y for wear and cracks.



- Inspect the kick idle gear and needle bearing for damage and wear.

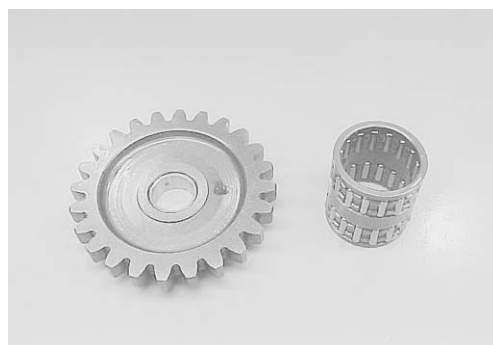

CLUTCH SLEEVE HUB REASSEMBLY

- Install the washer ② and needle bearing ①.
- Apply transmission oil to the needle bearing ①.
- Install the kick idle gear ③ and snap ring ④.

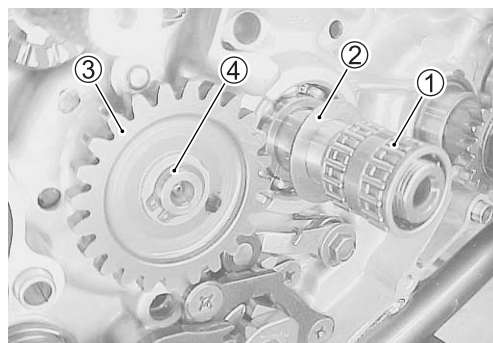

- Install the primary driven gear ass'y and washer.



- Install the clutch sleeve hub, lock washer ① and clutch sleeve hub nut ②.

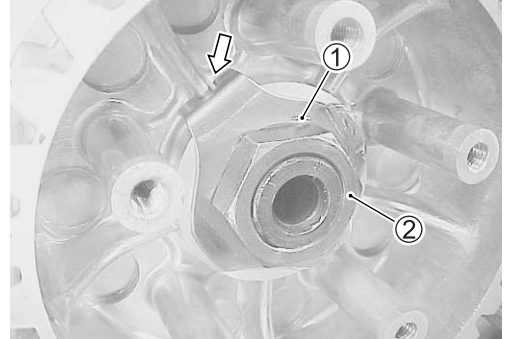

- Tighten the clutch sleeve hub nut with the special tool to the specified torque.

 **09920-53740: Clutch sleeve hub holder**

 **Clutch sleeve hub nut: 70 N·m (7.0 kgf-m, 51.0 lb-ft)**

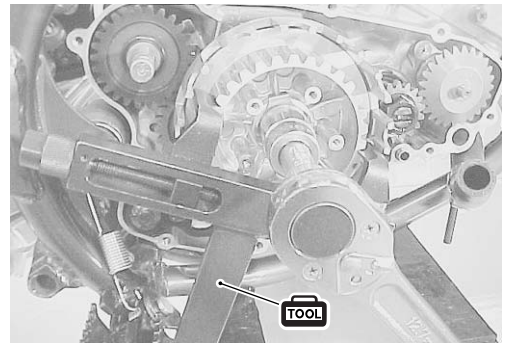

- Bend the lock washer to secure the nut ①.

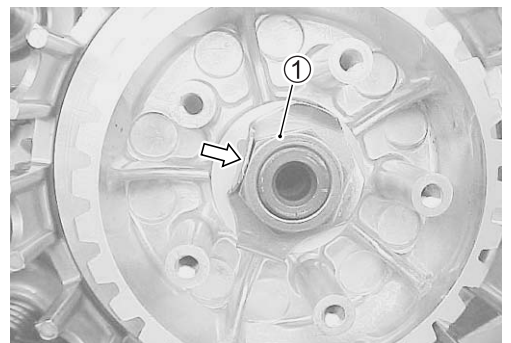

- Reassemble the clutch plates and pressure plate. (☞ 7-4)
- Install the dowel pins.
- Replace the gasket with a new one.
- Install the clutch cover and bolts. Tighten the clutch cover bolts diagonally. (☞ 7-5)
- Connect the radiator hose.
- Install the clutch release arm and kick starter lever.
- Reassemble the rear brake pedal. (☞ 15-14)
- Pour transmission oil. (☞ 2-7)
- Pour engine coolant. (☞ 2-8)

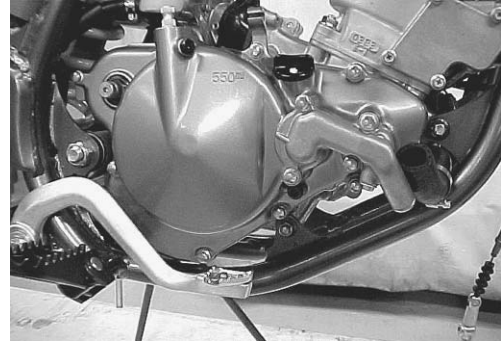

KICK STARTER

CONTENTS

CONSTRUCTION	8- 2
KICK STARTER	8- 2
KICK STARTER	8- 3
REMOVAL	8- 3
INSPECTION	8- 4
REASSEMBLY	8- 4

CONSTRUCTION KICK STARTER

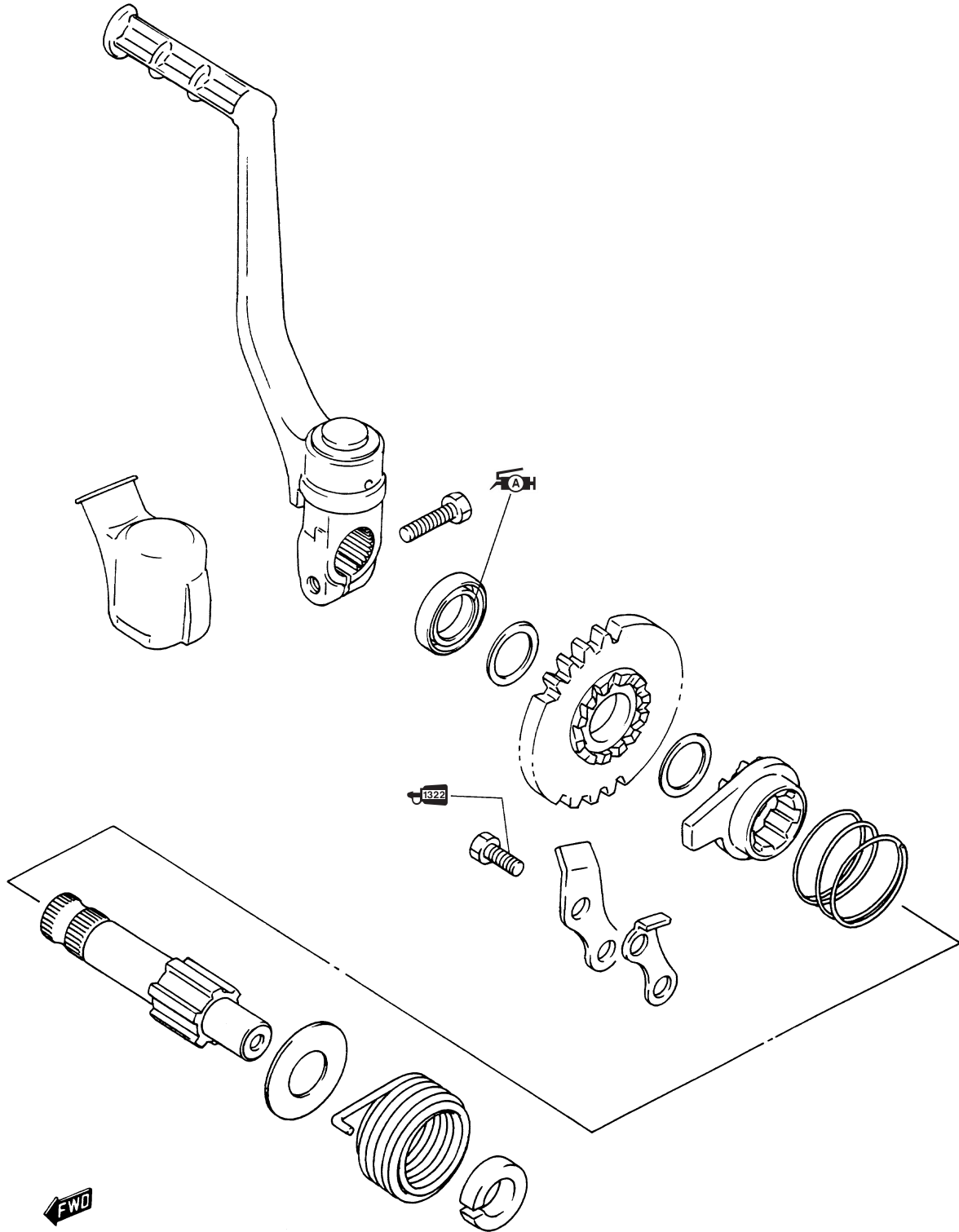

KICK STARTER REMOVAL

- Drain transmission oil. (☞ 2-7)
- Drain engine coolant.
- Remove the kick starter lever.
- Remove the clutch assembly. (☞ 7-5)

- Remove the snap ring ①.
- Remove the kick idle gear ②.
- Remove the kick starter drive gear ③.

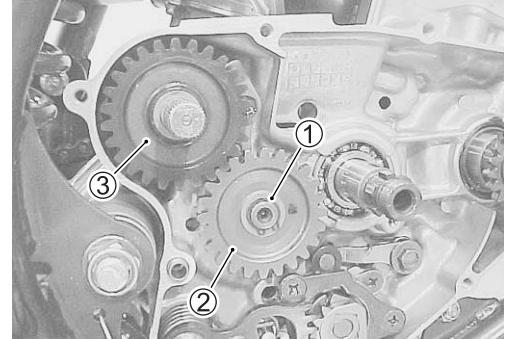

- Install the kick starter lever temporarily to remove the kick starter shaft.
- Turn the kick starter lever counterclockwise until the kick starter ④ come off the kick starter guide ⑤.

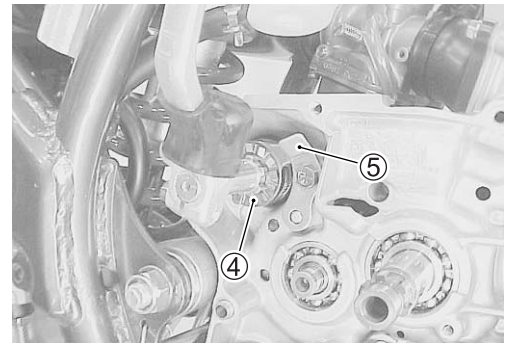

- Remove the following parts from the kick starter shaft:
 - Spacer ⑥
 - Kick return spring ⑦
 - Washer ⑧
 - Kick starter ⑨
 - Spring ⑩
 - Kick starter shaft ⑪

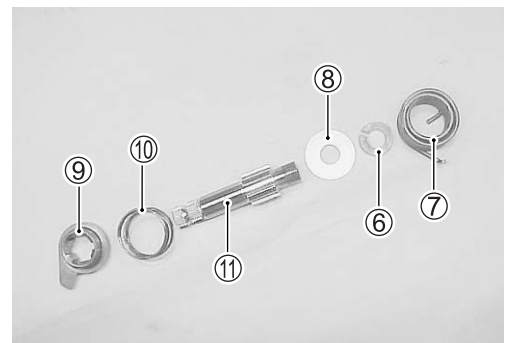

- Remove the kick starter guide ⑫ and kick starter stopper.

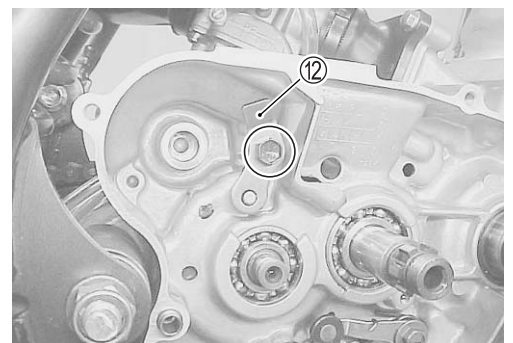

INSPECTION

- Inspect the oil seal ① for oil leakage and oil seal lip damage.

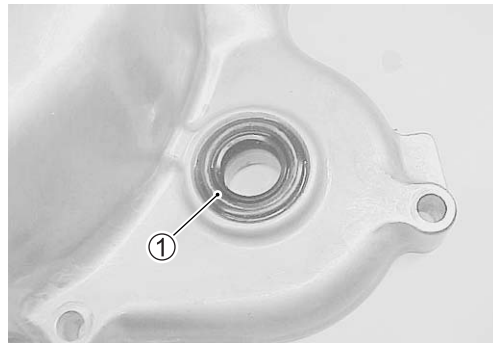

- Inspect the return spring ② for damage.
- Inspect the kick shaft ③ and drive gear for contact surface wear.

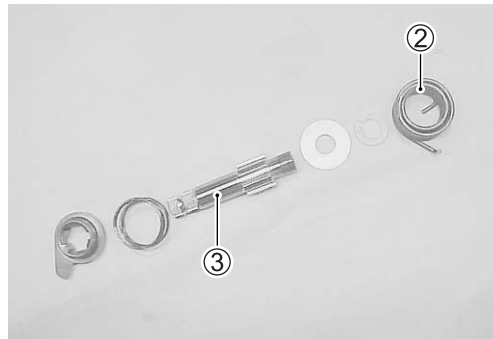

- Inspect the kick drive gear teeth for damage.
- Inspect the kick drive gear ratchet part for wear and damage.
- Inspect the kick starter stopper ④.

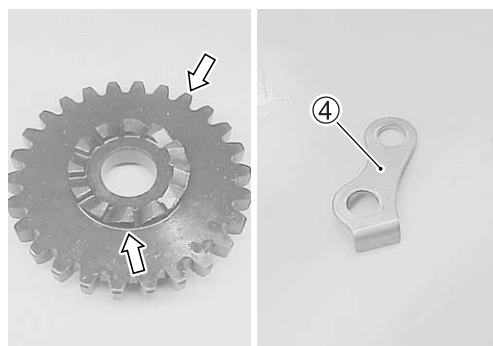

REASSEMBLY

- Install the kick starter stopper and kick starter guide.
- Apply THREAD LOCK SUPER "1322" to the bolt.
- Tighten the bolt.

 **99000-32110: THREAD LOCK SUPER "1322"**

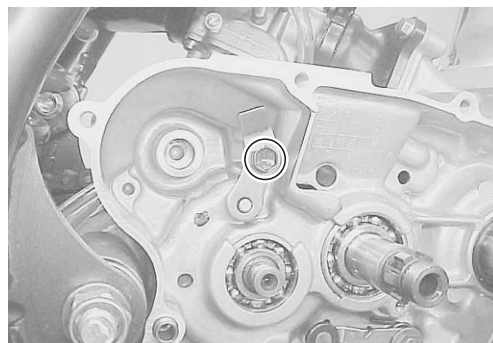

- Install the return spring ① into the kick shaft's hole.
- Install them to the crankcase.

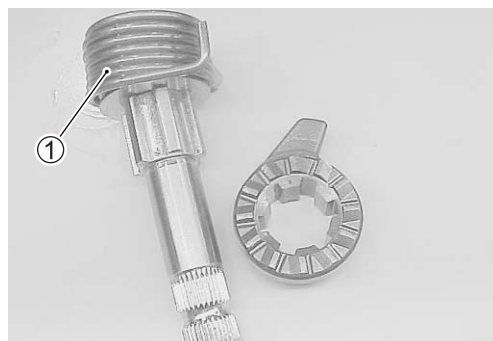

- Install the kick shaft assembly to the crankcase.
- Hook the return spring to the crankcase's hole.
- Install the kick starter to the kick shaft.





NOTE:

Be sure to align the punch marks on the kick starter and kick starter shaft when installing the kick starter.

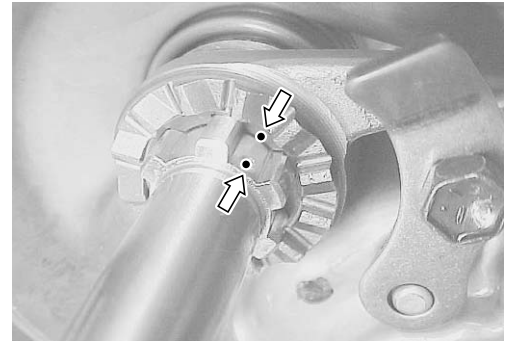
- Reassemble the kick idle gear.
- Reassemble the primary driven gear ass'y and clutch.
( 7-6)



- Reassemble the kick starter lever as shown.
 - Ⓐ: CORRECT
 - Ⓑ: INCORRECT
- Reassemble the clutch release arm.
- Reassemble the rear brake pedal. ( 15-14)
- Pour transmission oil. ( 2-7)
- Pour engine coolant. ( 2-8)

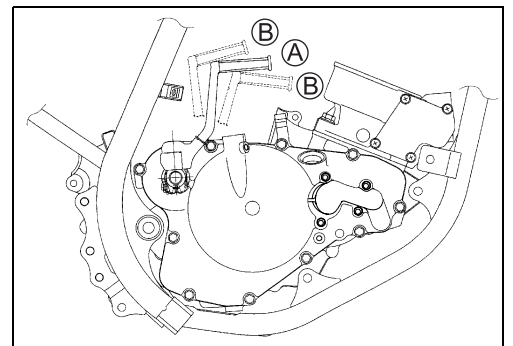

- Inspect the clutch lever play.
- Inspect for transmission oil leaks.
- Inspect the kick starter for smooth movement.

- MEMO -

GEARSHIFTING

CONTENTS

CONSTRUCTION	9- 2
GEARSHIFT LINKAGE	9- 2
GEARSHIFT LINKAGE	9- 3
REMOVAL	9- 3
INSPECTION	9- 4
REASSEMBLY	9- 4

CONSTRUCTION GEARSHIFT LINKAGE

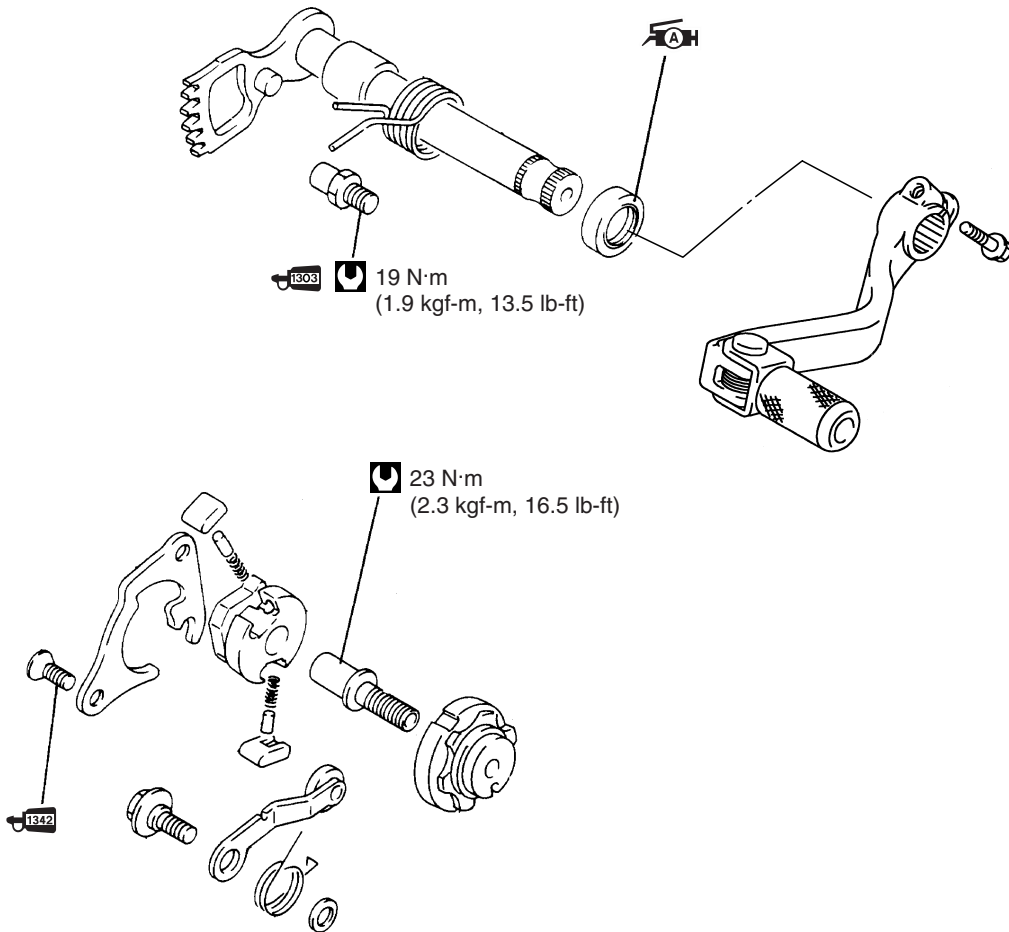

GEARSHIFT LINKAGE REMOVAL

- Drain transmission oil. (☞ 2-7)
- Drain engine coolant. (☞ 12-3)
- Remove the kick starter lever and clutch assembly. (☞ 7-5)
- Remove the gearshift lever.

- Remove the gearshift shaft ②.

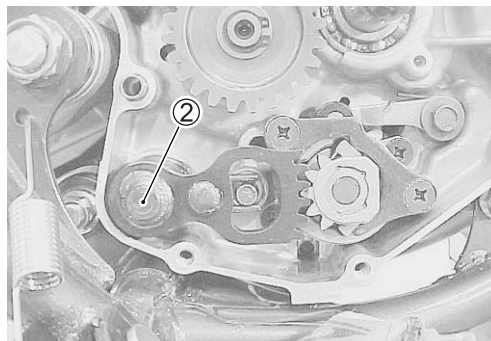

- Remove the two screws. Remove the pawl lifter ③.
- Remove the gearshift cam shifter ④.

NOTE:

Be careful that the pins and springs do not fly off.

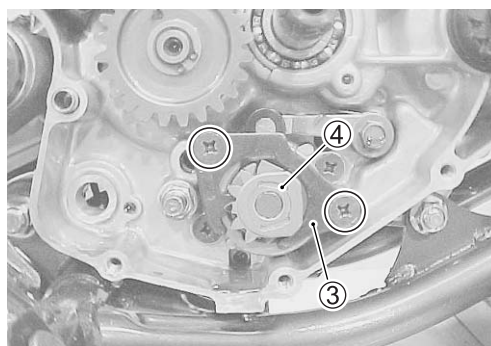

- Remove the gearshift pawls ⑤, pins ⑥ and springs ⑦.

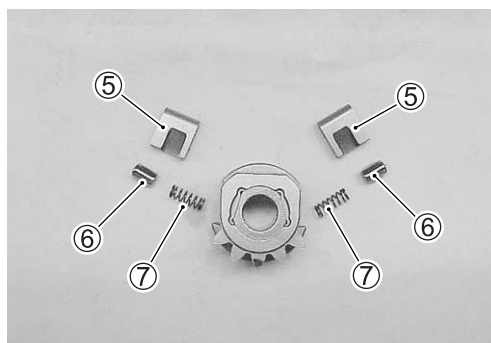

- Loosen the gearshift cam bolt ⑧ and remove the stopper plate ⑨.

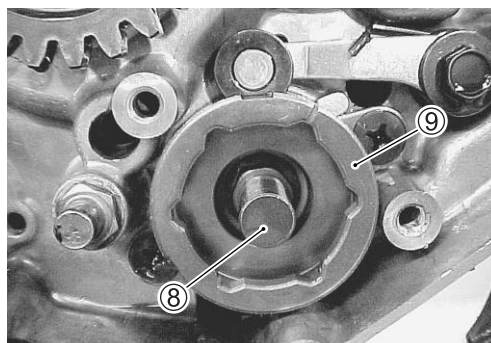

- Remove the gearshift cam stopper ①.
- Remove the spring ②.

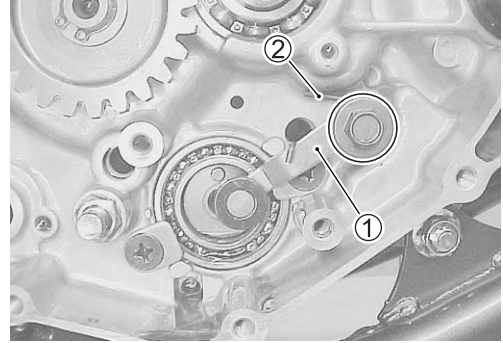

INSPECTION

- Inspect the gearshift shaft ① for bends and damage.
 - Inspect the return spring ② for damage.
-
- Inspect the pawls ③, springs ④ and pins ⑤ for damage.

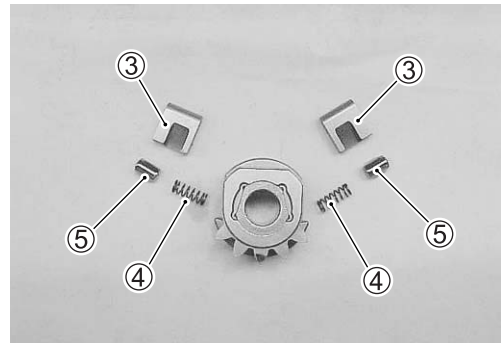

- Inspect the gearshift cam stopper.



REASSEMBLY

- Reassemble the washer ① and gearshift cam stopper ② and the spring ③.

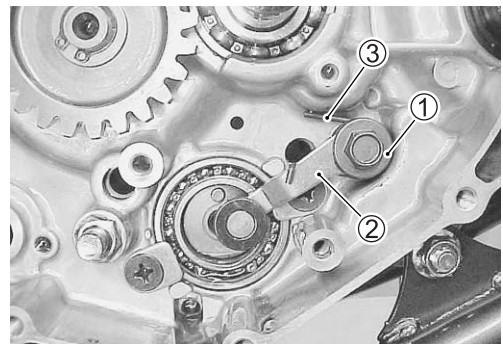

- Align the pin groove **A** with the pin **B** when installing the stopper plate **1**.

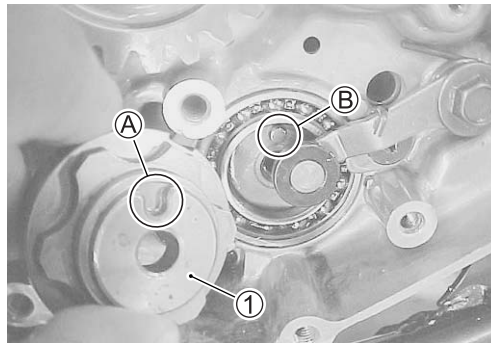

- Tighten the gear shift cam bolt **2**.

 **Gearshift cam bolt: 23 N·m (2.3 kgf·m, 16.5 lb·ft)**

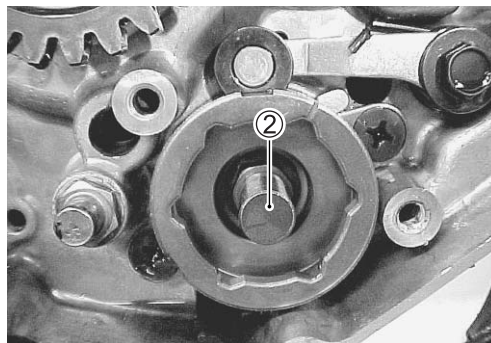

- Install the springs, pins and pawls to the shifter. Wider side **A** of pawl should be positioned outside.

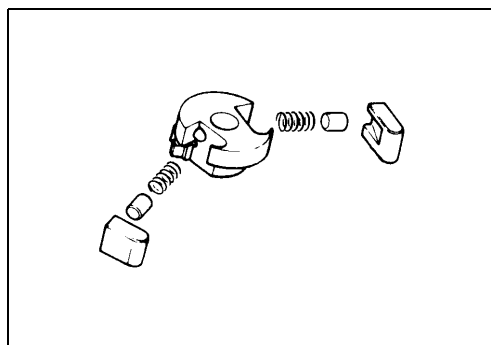
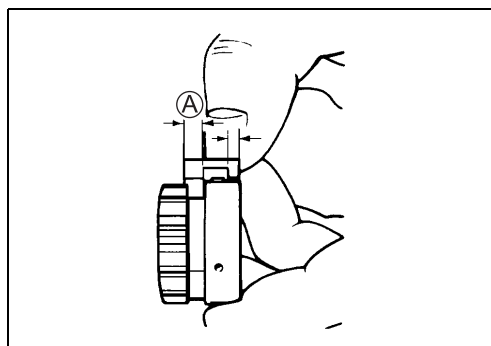

- With the pawls held in pushed position, install the pawl lifter **3**.

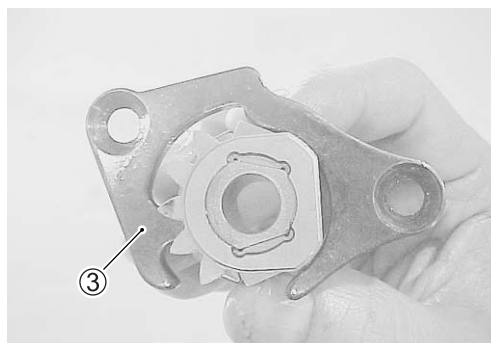

- Reassemble the gearshift cam shifter and pawl lifter.
- Apply THREAD LOCK SUPER “1322” to the screws.
- Tighten the screws.

 99000-32110: THREAD LOCK SUPER “1322”

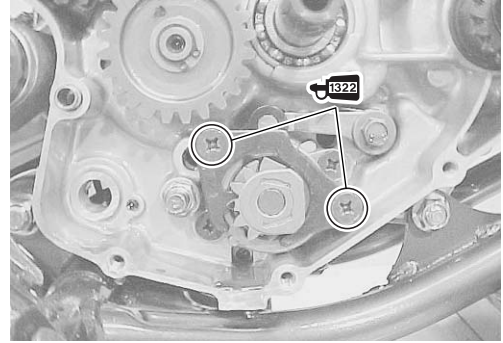

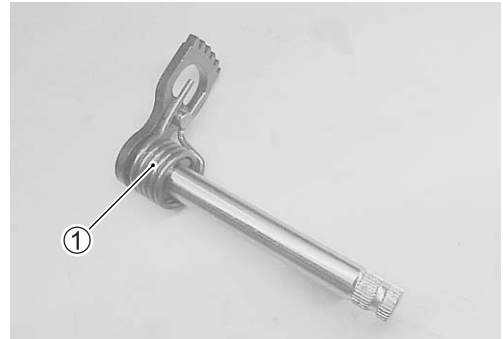

- Reassemble the gearshift return spring ① to the gearshift shaft properly.

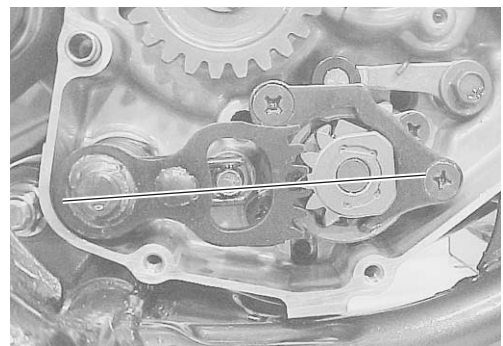

- Align the center teeth on the gearshift shaft with the center teeth on the gearshift cam shifter.



- Install the gearshift lever.
- Reassemble the clutch and clutch cover. ( 7-6)
- Install the kick starter lever, and clutch release arm.
- Pour transmission oil. ( 2-7)
- Pour engine coolant. ( 2-8)

TRANSMISSION AND CRANKSHAFT

CONTENTS

CONSTRUCTION	10- 2
TRANSMISSION AND CRANKSHAFT	10- 2
ENGINE BOTTOM SIDE	10- 3
PRIMARY DRIVE GEAR REMOVAL	10- 3
CRANKCASE SEPARATION	10- 3
TRANSMISSION REMOVAL	10- 4
CRANKSHAFT REMOVAL	10- 4
TRANSMISSION INSPECTION	10- 4
CRANKSHAFT INSPECTION	10- 6
OIL SEAL INSPECTION, REMOVAL AND INSTALLATION	10- 6
BEARING INSPECTION, REMOVAL AND INSTALLATION	10- 7
CRANKSHAFT INSTALLATION	10- 8
TRANSMISSION REASSEMBLY	10- 9
CRANKCASE REASSEMBLY	10-10
PRIMARY DRIVEN GEAR REASSEMBLY	10-11

CONSTRUCTION TRANSMISSION AND CRANKSHAFT

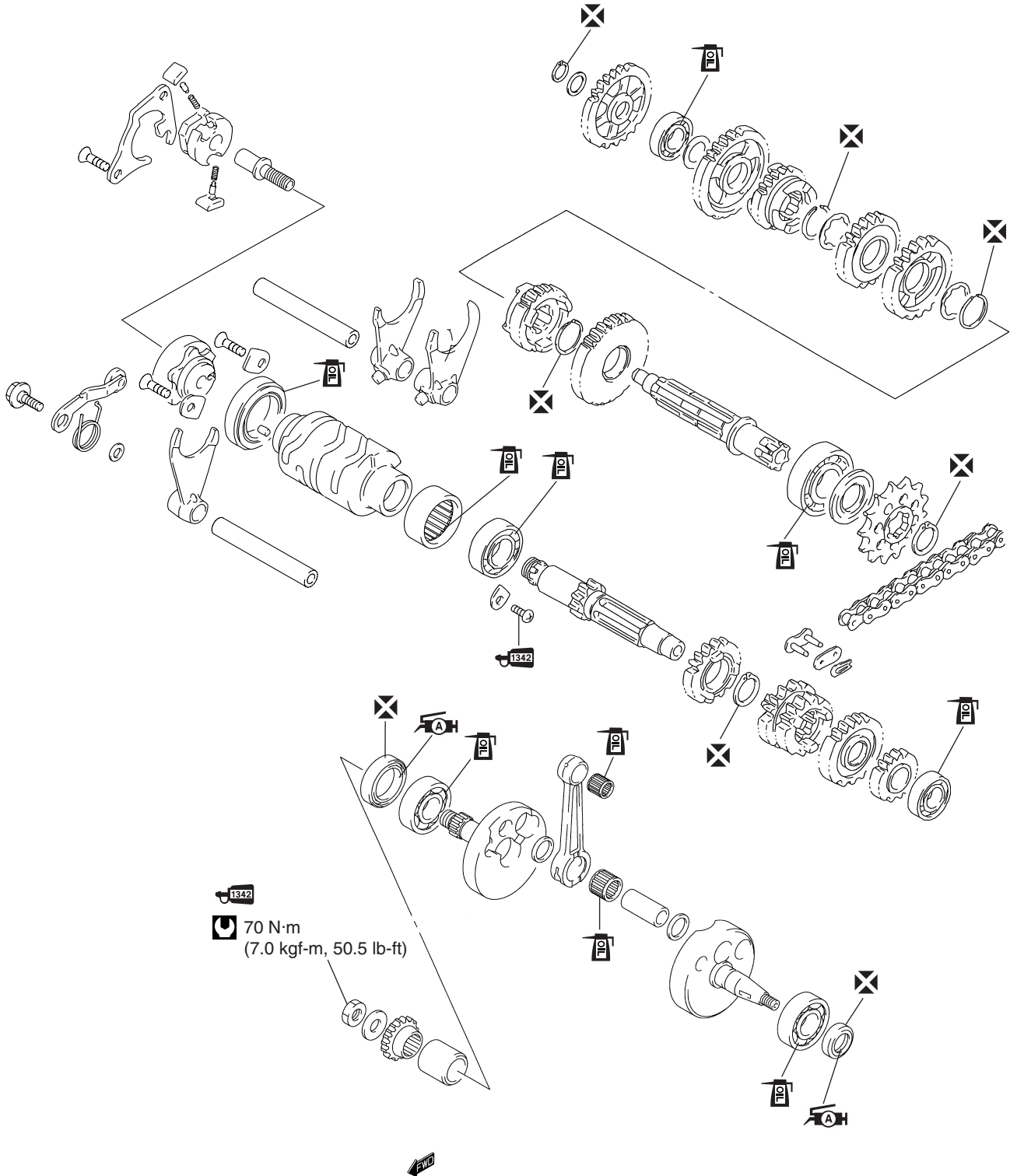

ENGINE BOTTOM SIDE

- Dismount the engine. (🔧 5-2)

NOTE:

The following parts must be removed before disassembling the engine bottom side (crankcase).

- Remove the engine sprocket cover and engine sprocket.
- Remove the gearshift lever. (🔧 9-3)
- Remove the cylinder head, cylinder and piston. (🔧 6-3)
- Remove the intake pipe and reed valve. (🔧 11-5)
- Remove the magneto rotor and stator. (🔧 13-6)
- Remove the kick starter lever.
- Remove the clutch cover and clutch. (🔧 7-5)
- Remove the kick starter idle gear and kick starter shaft. (🔧 8-3)
- Remove the gearshift linkage. (🔧 9-3)
- Remove the exhaust valve governor. (🔧 6-11)

PRIMARY DRIVE GEAR REMOVAL

- Hold the conrod with the special tool and loosen the primary drive gear nut.
- Remove the primary drive gear nut.

 **09910-20116: Conrod holder**

NOTE:

The primary drive gear nut has left-hand thread.

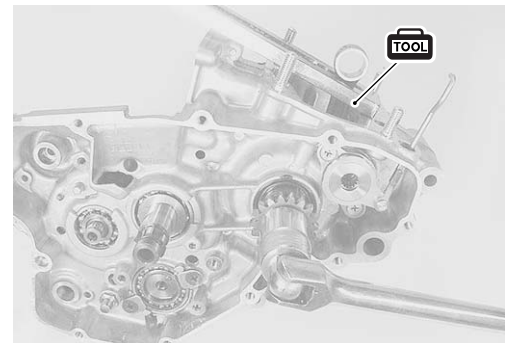

CRANKCASE SEPARATION

- Remove the crankcase bolts.

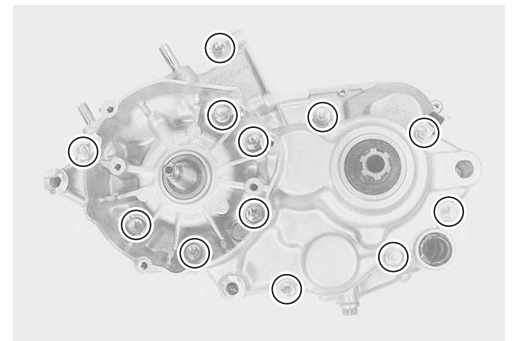

- Separate the crankcase with the special tool.

 **09920-13120: Crankcase separating tool**

NOTE:

* Set the crankcase separating tool to the clutch side of the crankcase.

* Separate the crankcase gradually while hitting the crankcase boss and countershaft softly with a plastic hammer.

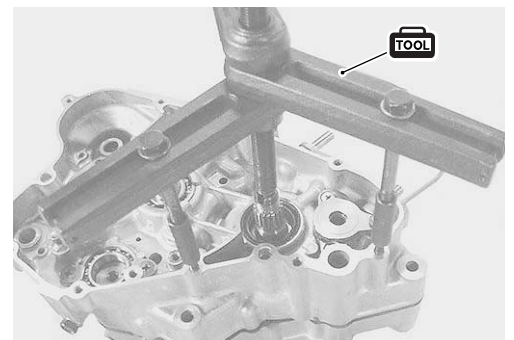

TRANSMISSION REMOVAL

- Remove the gearshift fork shafts ① and forks ②.
- Remove the gearshift cam ③.

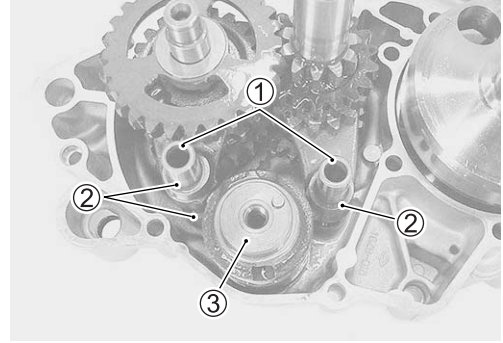

- Remove the driveshaft ass'y ④ and countershaft ass'y ⑤.

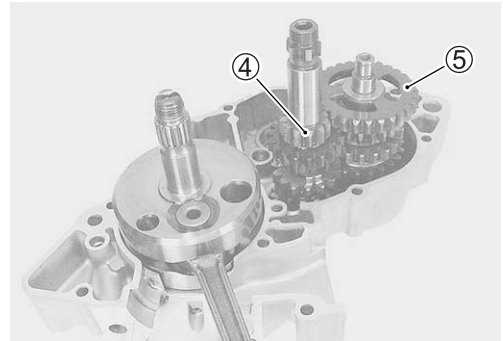

CRANKSHAFT REMOVAL

- Remove the crankshaft with the special tool.

 09920-13120: Crankcase separating tool

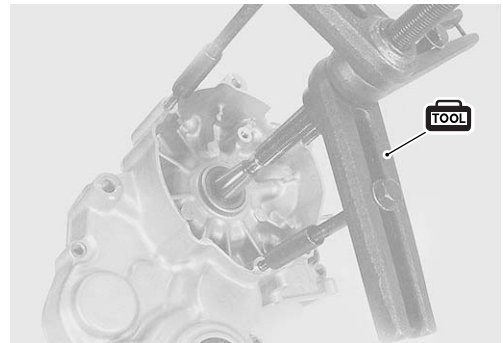

TRANSMISSION INSPECTION

- Inspect the gear teeth, dogs, and gearshift grooves for abnormal wear and damage.
- Inspect the bushings and splines for abnormal wear and discoloration.



- Inspect the gearshift cam groove for abnormal wear and damage.



- Inspect the gearshift forks and shafts for wear and damage.

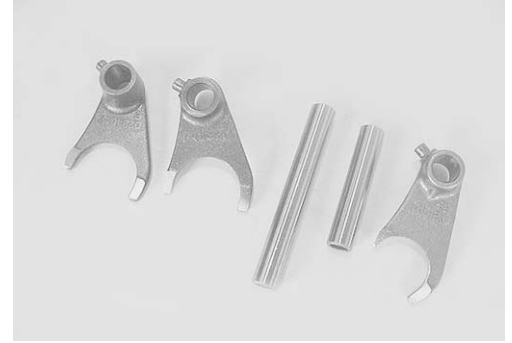

- Measure the gearshift fork thickness with a vernier calipers.

DATA Gearshift fork thickness

	Standard
No. 1	3.80 – 3.90 mm (0.150 – 0.154 in)
No. 2 & No. 3	4.30 – 4.40 mm (0.169 – 0.173 in)

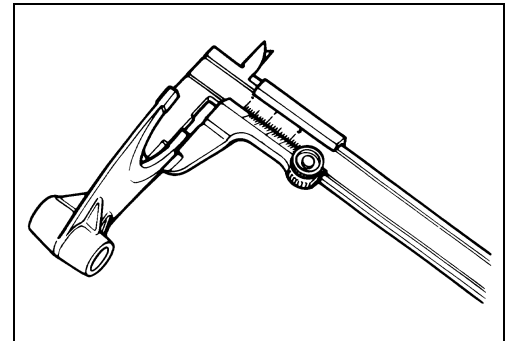

- Measure the gearshift fork groove width with a vernier calipers.

DATA Gearshift fork groove width

	Standard
No. 1	3.95 – 4.05 mm (0.156 – 0.159 in)
No. 2 & No. 3	4.45 – 4.55 mm (0.175 – 0.179 in)

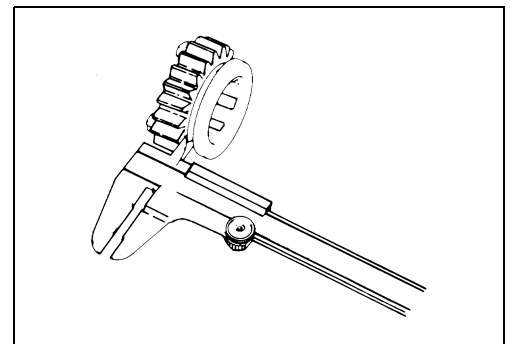

- Measure the gearshift fork to groove clearance with a thickness gauge.

DATA Gearshift fork – Groove clearance
 Service Limit: 0.45 mm (0.018 in)

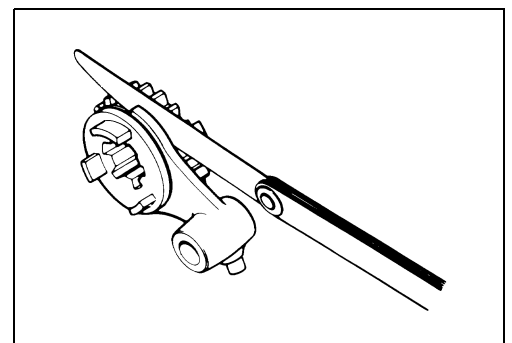

CRANKSHAFT INSPECTION

- Measure the crankshaft runout with V-blocks and dial gauge.

DATA Crankshaft runout

Service Limit: 0.05 mm (0.002 in)

TOOL 09900-20607: Dial gauge (1/100 mm)

09900-20701: Magnetic stand

09900-21304: V-block

NOTE:

Place the crankshaft onto the V-blocks so that it becomes horizontally.

Measure the runout from the tips of the crankshaft.

- Measure the crankshaft web to web width with a vernier calipers.

DATA Width between webs

Standard: 44.9 – 45.1 mm (1.767 – 1.775 in)

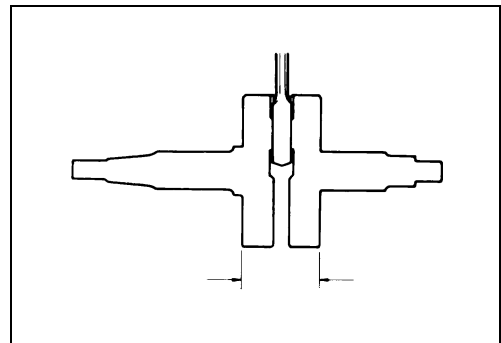
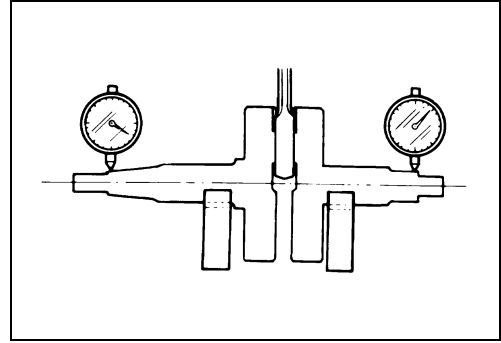

OIL SEAL INSPECTION, REMOVAL AND INSTALLATION

- Inspect each oil seal lip for wear and damage.

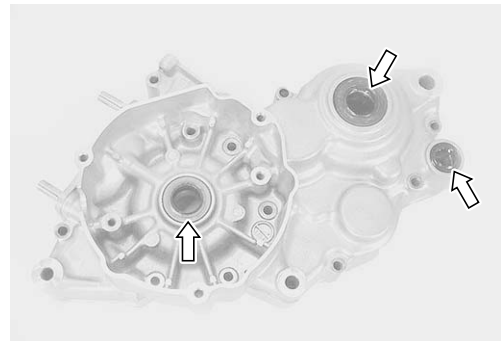

- Remove the oil seal with the special tool.

TOOL 09913-50121: Oil seal remover



- Install each new oil seal with the special tools.
- Apply grease to each oil seal lip.

TOOL 09913-70210: Bearing installer set

NOTE:

Be sure to check the direction of the crankshaft bearing oil seals before fitting them.

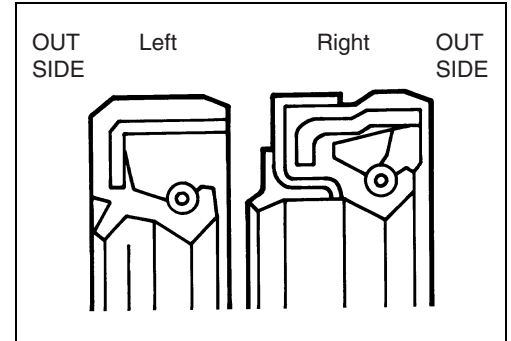

BEARING INSPECTION, REMOVAL AND INSTALLATION

- Inspect the bearings for play, discoloration, wear and seizure.
- Move the inner race by finger and inspect for smooth movement.

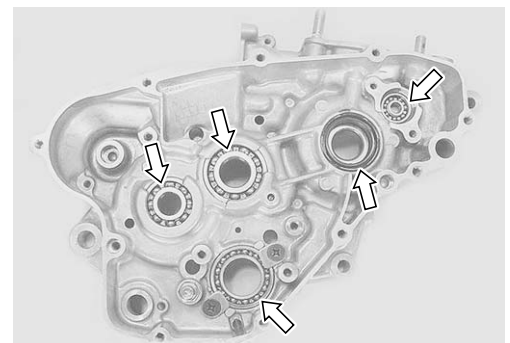
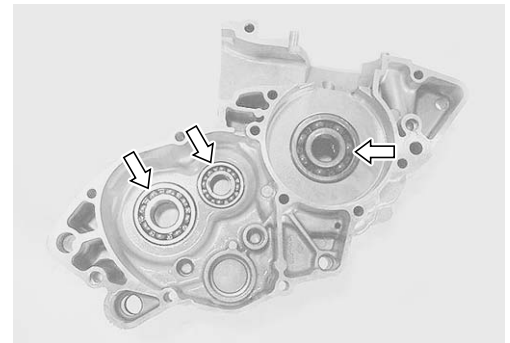

- Remove the bearing retainers ①, ②.
- Remove the bearings with the special tool.

TOOL 09913-70210: Bearing installer set

- Remove the bearing ③ with the special tool.

TOOL 09921-20220: Bearing remover set

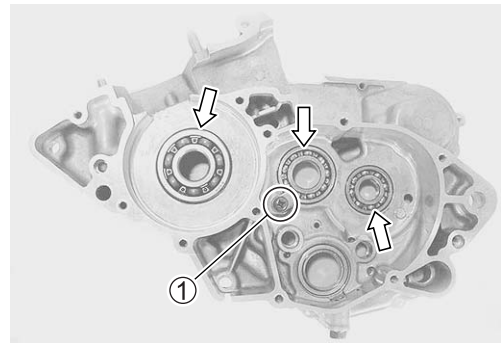
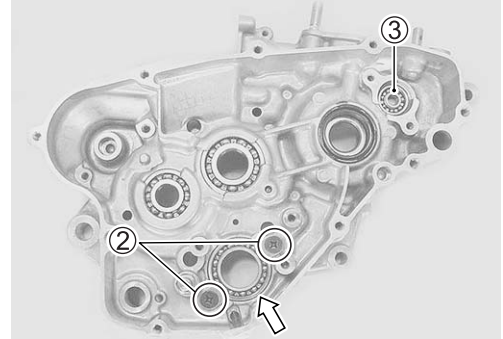
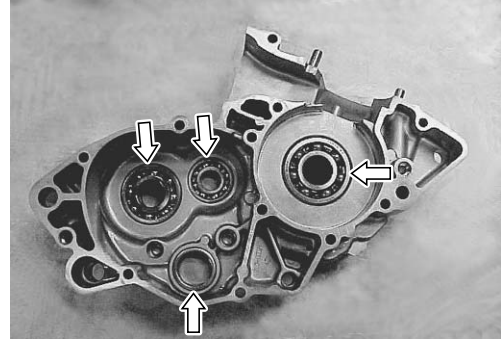

CRANKSHAFT INSTALLATION

- Install the crankshaft into the left crankcase half with the special tool.

TOOL 09910-32812: Crankshaft installer

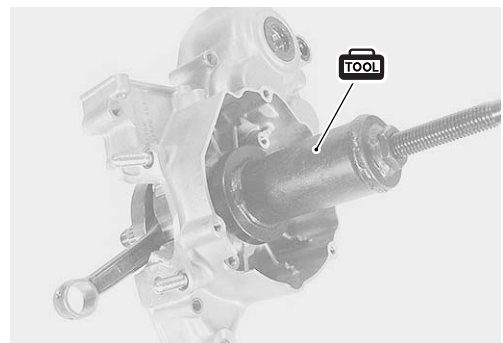

TRANSMISSION REASSEMBLY

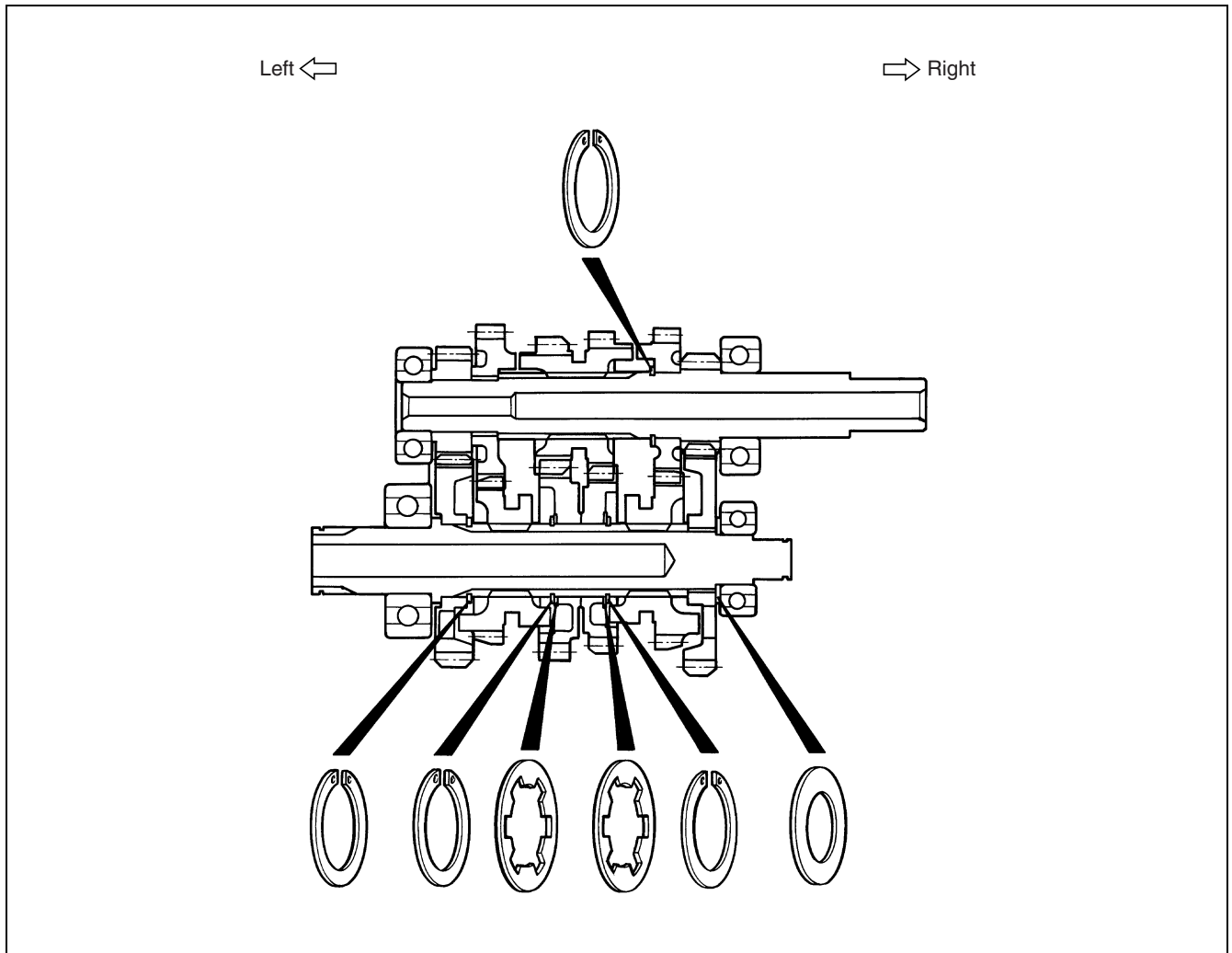

NOTE:

- * Seat the snap ring in the groove and locate its end as shown in the illustration.
- * Replace the removed snap ring with a new one.

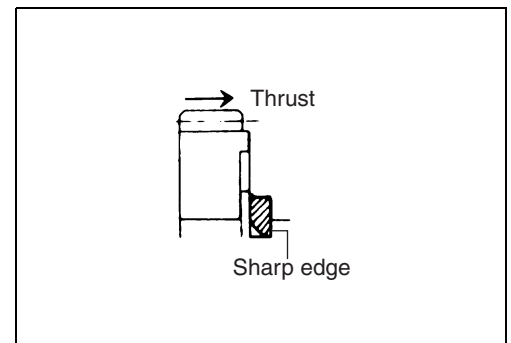

- Apply transmission oil to the following parts: driveshaft, countershaft, transmission gears, bearings, gearshift forks, gearshift shafts, gearshift cam.
- Reassemble the driveshaft ① and countershaft ② with gears installed.

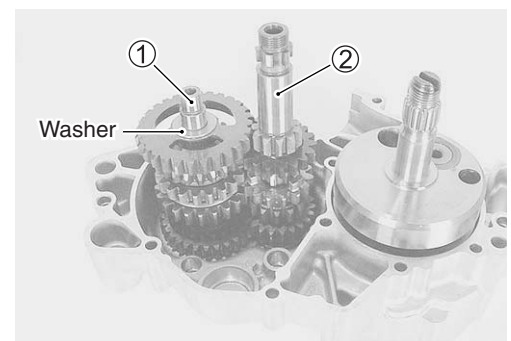

- Install the gear shift forks ①, ②, ③.

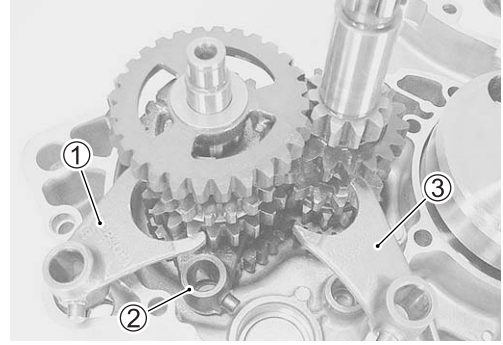

- Install the gear shift cam ③ and gearshift shafts ④, ⑤.

NOTE:

Turn the gearshift cam to the neutral position and confirm that the driveshaft and countershaft turn without resistance.

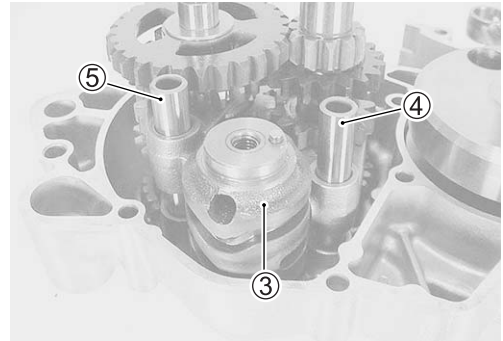

CRANKCASE REASSEMBLY

- Install the new gasket ① and dowel pins ②.

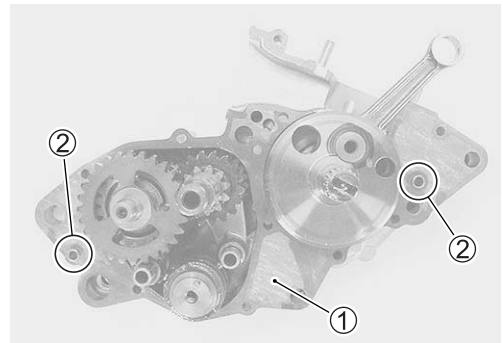

- Install the right crankcase half on the left crankcase half.
- Tighten the crankcase bolts.

🔧 Crankcase bolt: 10 N·m (1.0 kgf·m, 7.3 lb·ft)

NOTE:

Tighten the bolts gradually and diagonally to guide the crankshaft into the bearing. If it is hard to tighten the bolts, separate the crankcase and confirm that the transmission parts are assembled correctly.

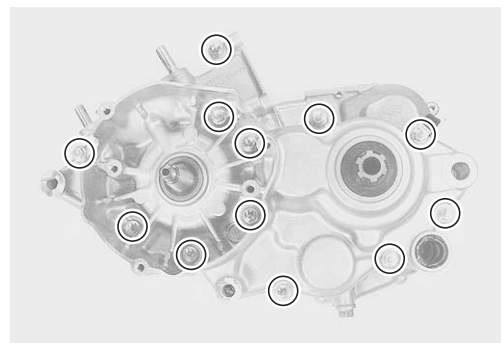

- Inspect the crankshaft for smooth movement.
- Apply grease to the oil seal's lip.
- Install the spacer ① to the crankshaft.

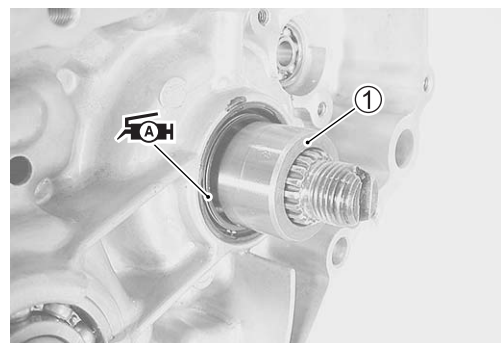

PRIMARY DRIVEN GEAR REASSEMBLY

- Install the primary driven gear and washer onto the crankshaft.
- Apply THREAD LOCK SUPER “1322” to the primary driven gear nut and tighten it to the specified torque with the special tool.

 **1322 99000-32110: THREAD LOCK SUPER “1322”**

 **09910-20116: Conrod holder**

 **Primary driven gear nut: 70 N·m (7.0 kgf·m, 50.5 lb-ft)**

NOTE:

The primary driven gear nut has left-hand thread.

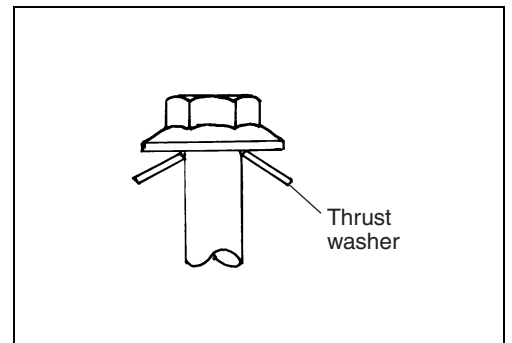
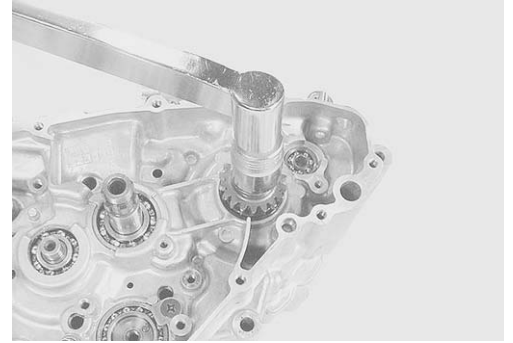

- Reassemble the gearshift linkage. (☞ 9-4)
- Reassemble the kick idle gear and kick starter shaft. (☞ 8-4)
- Reassemble the exhaust valve governor. (☞ 6-13)
- Reassemble the stator and magnet rotor. (☞ 13-6)
- Reassemble the clutch and clutch cover. (☞ 7-6)
- Reassemble the kick starter lever.
- Reassemble the piston and cylinder. (☞ 6-9 and -10)
- Remount the engine. (☞ 5-5)
- Pour transmission oil and coolant. (☞ 2-7 and -8)

– MEMO –

FUEL SYSTEM

CONTENTS

CONSTRUCTION	11- 2
FUEL SYSTEM	11- 2
CARBURETOR	11- 3
REMOVAL AND DISASSEMBLY	11- 3
INSPECTION	11- 5
REASSEMBLY	11- 5
REED VALVE	11- 5
REMOVAL	11- 5
INSPECTION	11- 5
REASSEMBLY	11- 6

CONSTRUCTION FUEL SYSTEM

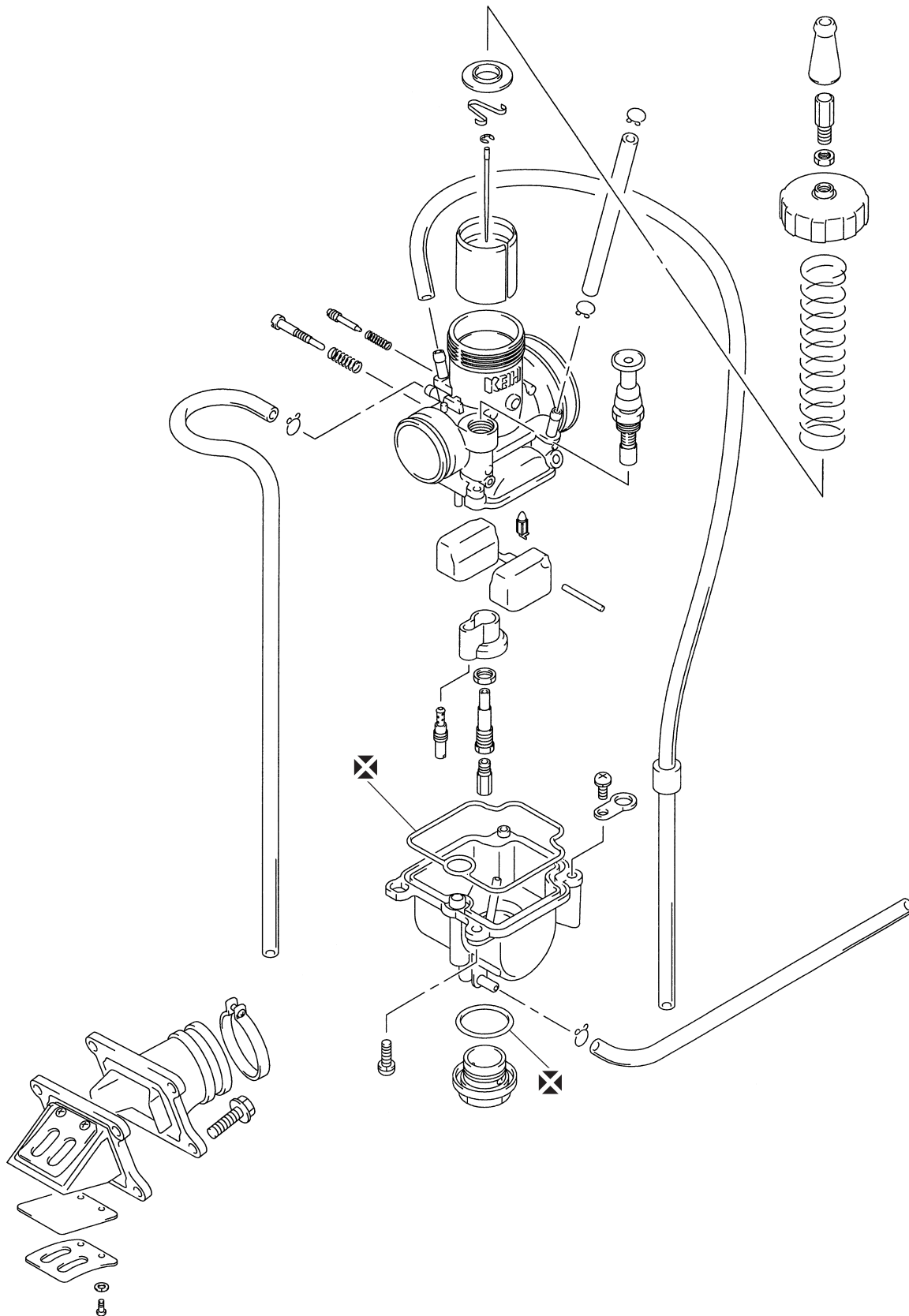

CARBURETOR REMOVAL AND DISASSEMBLY

- Remove the seat and fuel tank. (☞ 5-2)
- Turn the fuel valve lever to "OFF".
- Disconnect the fuel hose.
- Loosen the carburetor clamp screws and remove the carburetor.

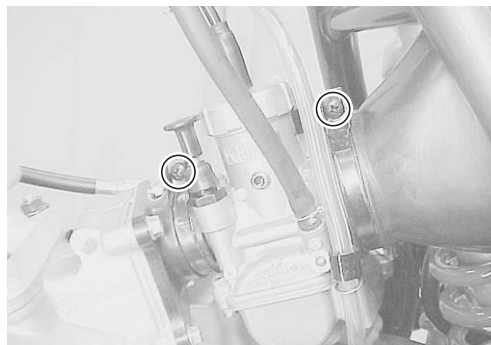

- Remove the carburetor top cap and throttle valve.



- Compress the spring ② with collar ③ and disconnect the throttle cable ① from the throttle valve.

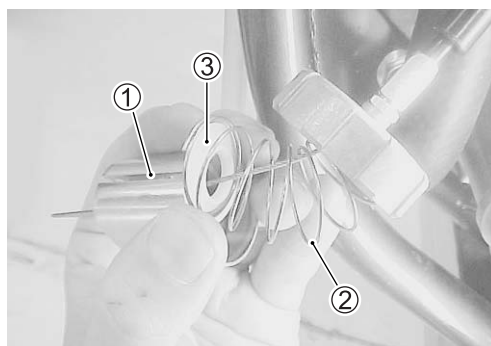

- Remove the spring ④ and jet needle ⑤ from the throttle valve.

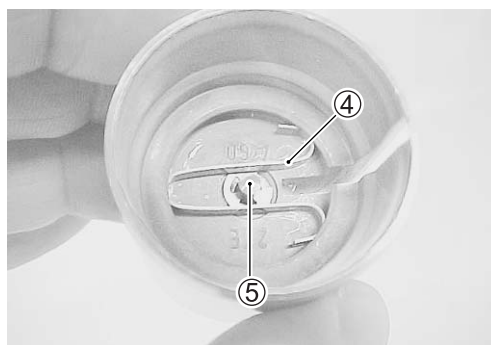

- Throttle valve spring ①
- Throttle valve collar ②
- Spring ③
- Jet needle ④
- Throttle valve ⑤

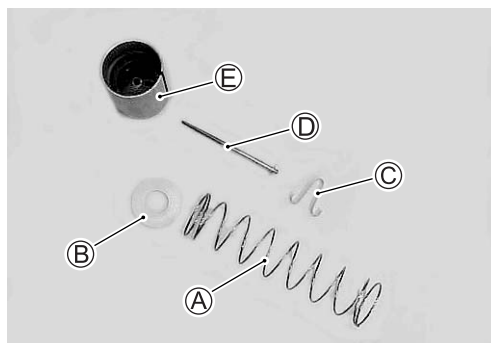

- Remove the air vent hoses ①, overflow hoses ② fuel hose ③.

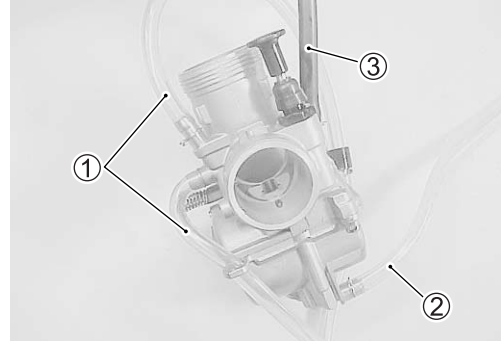

- Loosen the screws and remove the carburetor float chamber ⑤.

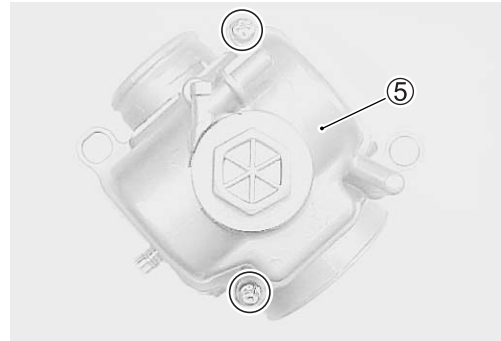

- Remove the float pin ⑥ and floats ⑦.
- Remove the jet holder ⑧.

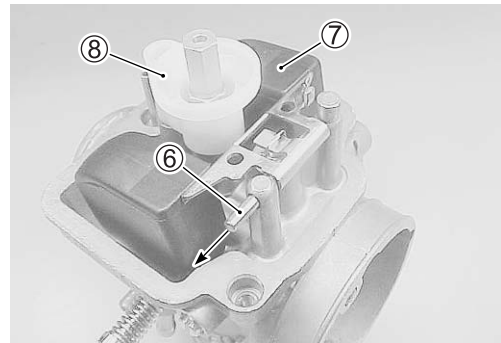

- Remove the needle valve ass'y ⑨.
- Remove the main jet ⑩, and slow jet ⑪.
- Remove the starter knob ⑫.

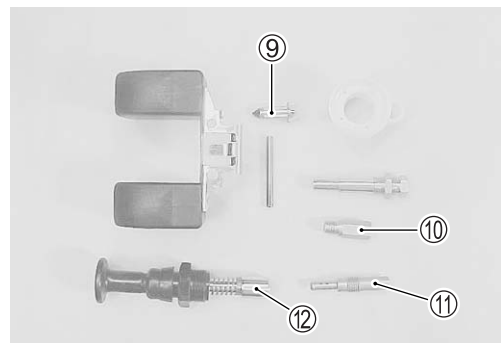

- Remove the pilot screw ⑬ and throttle stop screw ⑭.

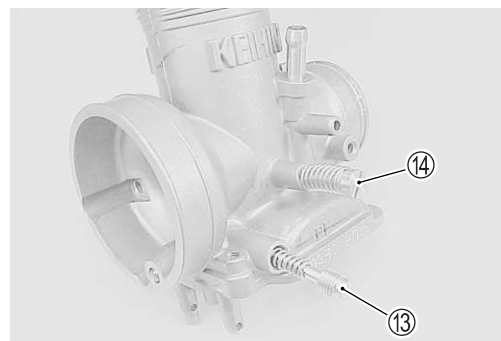

INSPECTION

- Inspect the following parts for damage:
 - Jet needle
 - Throttle valve
 - Float
- Inspect the following jets for clogging:
 - Main jet
 - Slow jet
 - Starter jet
- Inspect the needle valve for wear.
- Measure the float height with a vernier calipers. To measure the float height, tilt the carburetor until the float tip just contacts the float valve.

DATA Standard float height (A): $19 \pm 0.5 \text{ mm}$ ($0.75 \pm 0.02 \text{ in}$)

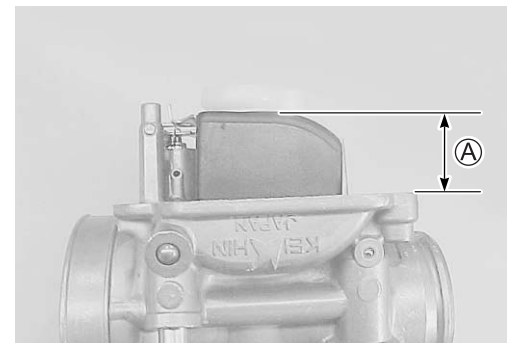
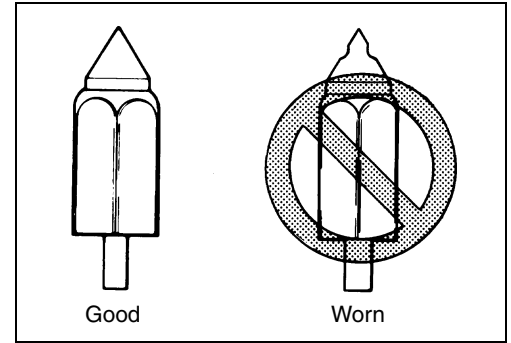

REASSEMBLY

Reverse the sequence of removal.

NOTE:

Fit the projection of the carburetor to the depression on intake pipe.

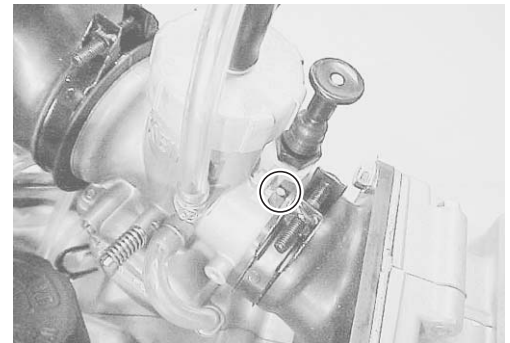

REED VALVE REMOVAL

- Remove the carburetor. (☞ 11-3)
- Remove the four bolts.
- Remove the intake pipe and reed valve.

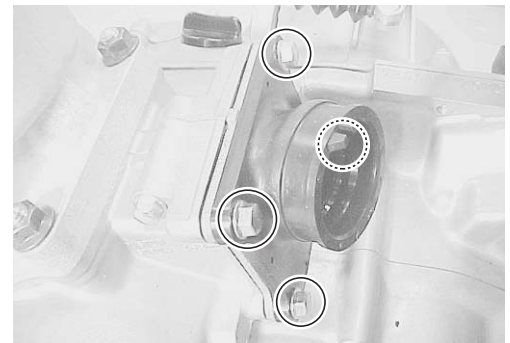

INSPECTION

- Inspect the reeds for damage.
- Inspect the reed valve stoppers for damage.
- Inspect the valve seat rubber for damage.

NOTE:

Be careful not to damage the removed reed valve ass'y.



REASSEMBLY

Reverse the sequence of removal.

COOLING SYSTEM

CONTENTS

CONSTRUCTION	12- 2
COOLING SYSTEM	12- 2
ENGINE COOLANT	12- 3
ENGINE COOLANT REPLACEMENT	12- 3
RADIATOR	12- 3
RADIATOR CAP INSPECTION	12- 3
RADIATOR REMOVAL	12- 4
COOLING SYSTEM INSPECTION	12- 4
RADIATOR INSTALLATION	12- 4
WATER PUMP	12- 5
WATER PUMP REMOVAL AND INSPECTION	12- 5
WATER PUMP REASSEMBLY	12- 6

CONSTRUCTION COOLING SYSTEM

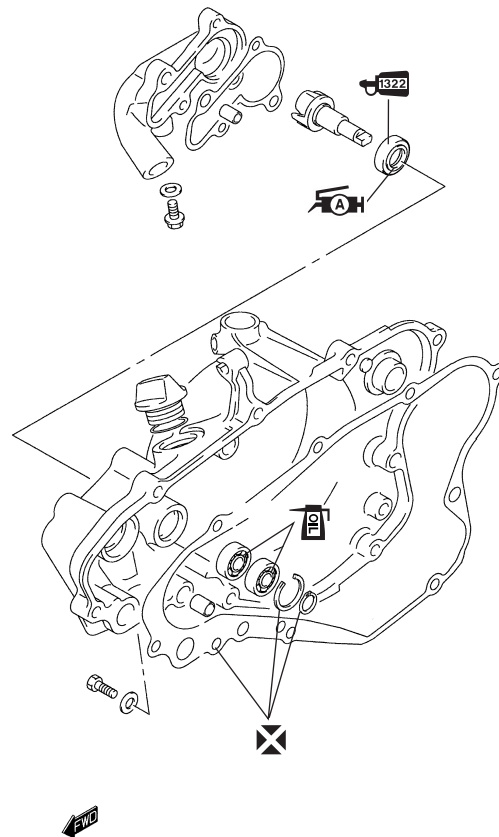
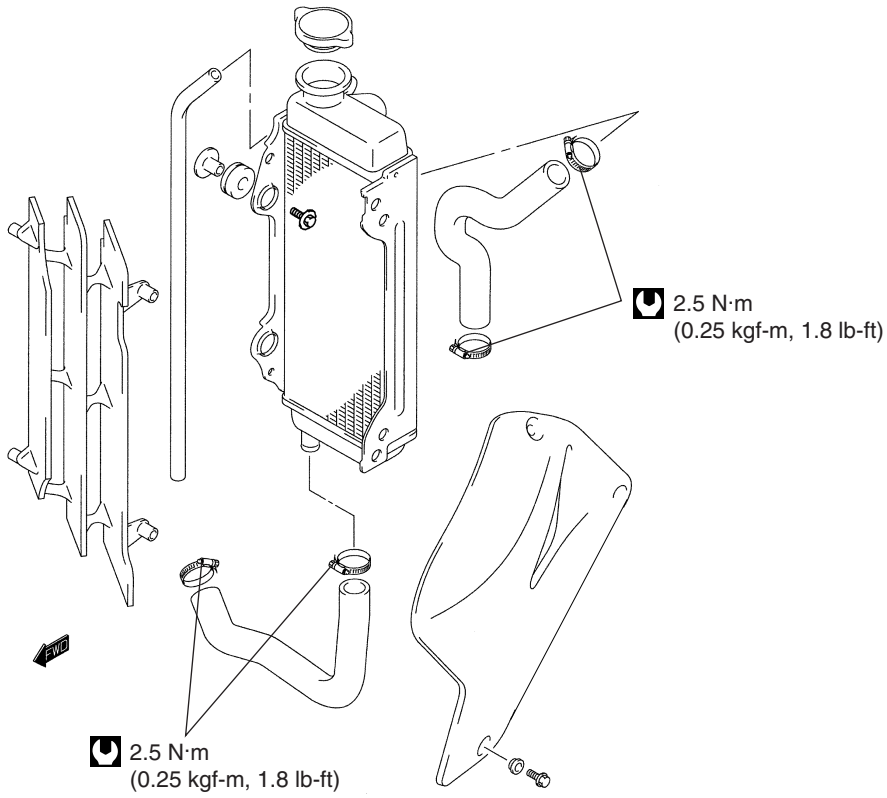

ENGINE COOLANT

ENGINE COOLANT REPLACEMENT

⚠ WARNING

You can be injured by scalding fluid or steam if you open the radiator cap when the engine is hot.

Do not open the radiator cap when the engine is hot.
Wait until engine cools.

- Place the motorcycle on a block.
- Remove the radiator cap.
- Drain engine coolant by removing the drain plug ① and disconnecting the radiator hose ②.
- Tighten the drain plug ① and connect the radiator hose ②.
- Pour engine coolant.

LLC Engine coolant capacity: 570 ml (1.2/1.0 US/Imp qt)

- Tighten the radiator cap firmly.
- Run the engine a few minutes and inspect the coolant level.



RADIATOR

RADIATOR CAP INSPECTION

- Inspect the radiator cap for function with a radiator cap pressure gauge.

DATA Radiator cap valve release pressure:
95 – 125 kPa (0.95 – 1.25 kgf/cm², 13.5 – 17.8 psi)

NOTE:

Apply water to radiator cap seal before fitting the radiator cap to the pressure gauge.

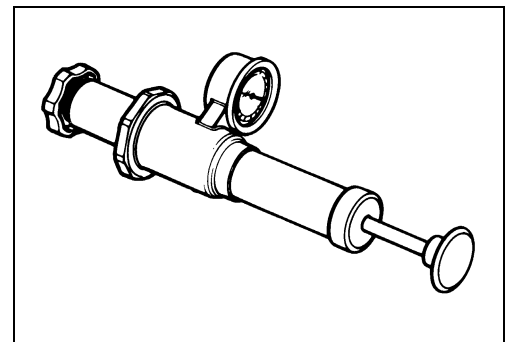

RADIATOR REMOVAL

- Remove the seat and fuel tank. (☞ 5-2)
- Drain engine coolant. (☞ 12-3)
- Disconnect all the radiator hoses.
- Remove the radiator by removing its mounting bolts.

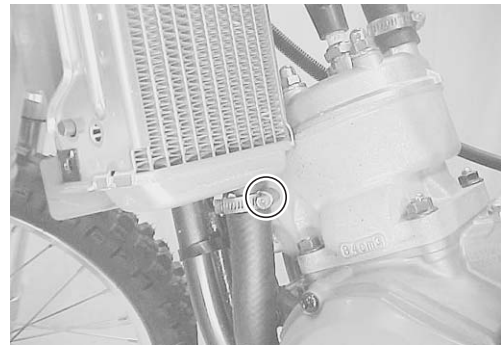
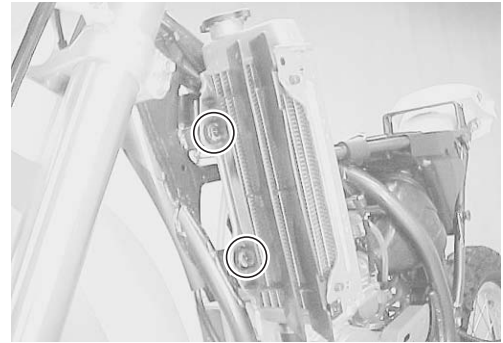

COOLING SYSTEM INSPECTION

Inspect the following items.

- Radiator coolant leakage
- Radiator hose cracks and deterioration
- Radiator mounting condition
- Radiator breather hose condition
- Radiator fin condition

RADIATOR INSTALLATION

Reverse the sequence of removal.

COOLING SYSTEM HOSE ROUTING ☞ 18-10 and -11

WATER PUMP

WATER PUMP REMOVAL AND INSPECTION

- Drain engine coolant and transmission oil. (☞ 12-3 and 2-7)
- Remove the water pump cover ①.
- Remove the clutch cover. (☞ 7-3)

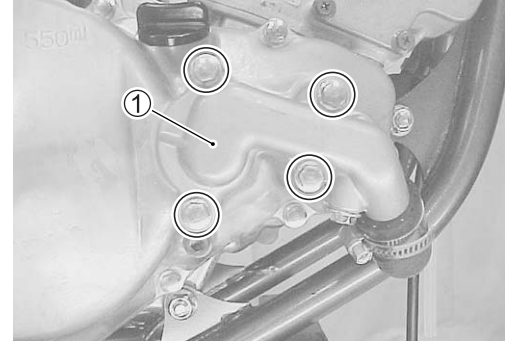

- Remove the snap rings ② with snap ring pliers.
- Remove the impeller.



- Inspect the impeller for damage.



- Inspect the bearing for smooth inner race movement.
- Remove the snap ring and bearing with the special tool.

TOOL 09916-44910: Valve guide driver



- Inspect the oil seal ① for damage.
- Remove the oil seal ① with the special tool.

TOOL 09913-50121: Oil seal remover

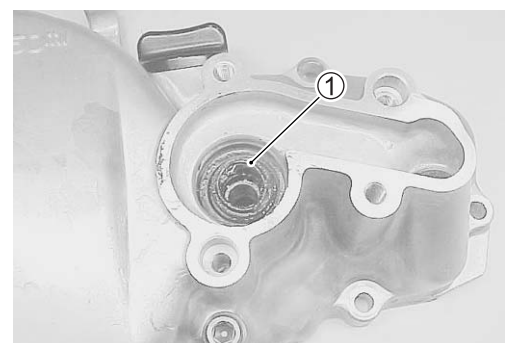

WATER PUMP REASSEMBLY

- Apply THREAD LOCK SUPER “1322” to the outer surface of the oil seal. Install the oil seal with a proper tool.

 **99000-32110: THREAD LOCK SUPER “1322”**

- Apply grease to the machanical seal lip.
- Insert the water pump shaft.

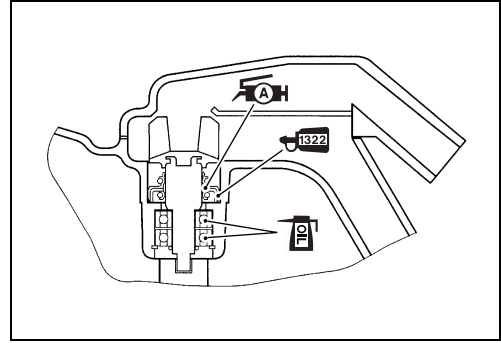

- Install the bearing with the special tool.

 **09916-44910: Valve guide driver**
09916-53340: Valve guide installer

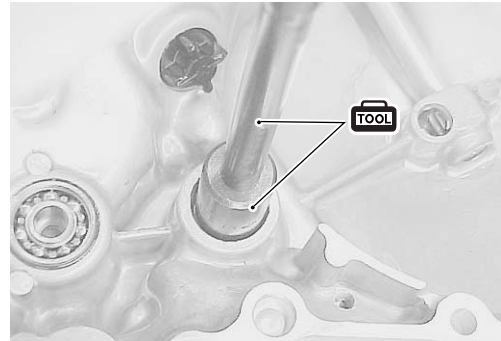

- Install the snap ring ①.

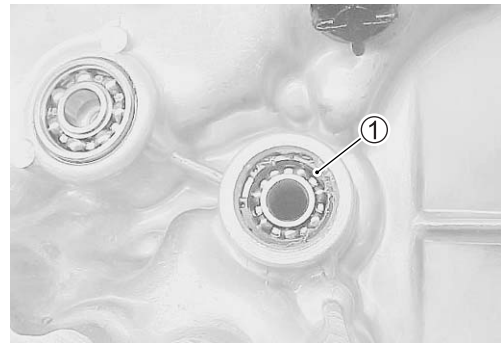

- Reassemble the clutch cover and water pump cover. (☞ 7-5)
- Connect the radiator hose.
- Pour engine coolant and transmission oil. (☞ 2-7 and -8)

ELECTRICAL SYSTEM

CONTENTS

CONSTRUCTION	13- 2
ELECTRICAL SYSTEM	13- 2
ELECTRICAL CIRCUIT	13- 2
IGNITION SYSTEM	13- 3
IGNITION COIL INSPECTION	13- 4
CDI UNIT INSPECTION	13- 4
STATOR COIL INSPECTION	13- 5
MAGNETO ROTOR AND STATOR REMOVAL AND REASSEMBLY	13- 5

CONSTRUCTION ELECTRICAL SYSTEM

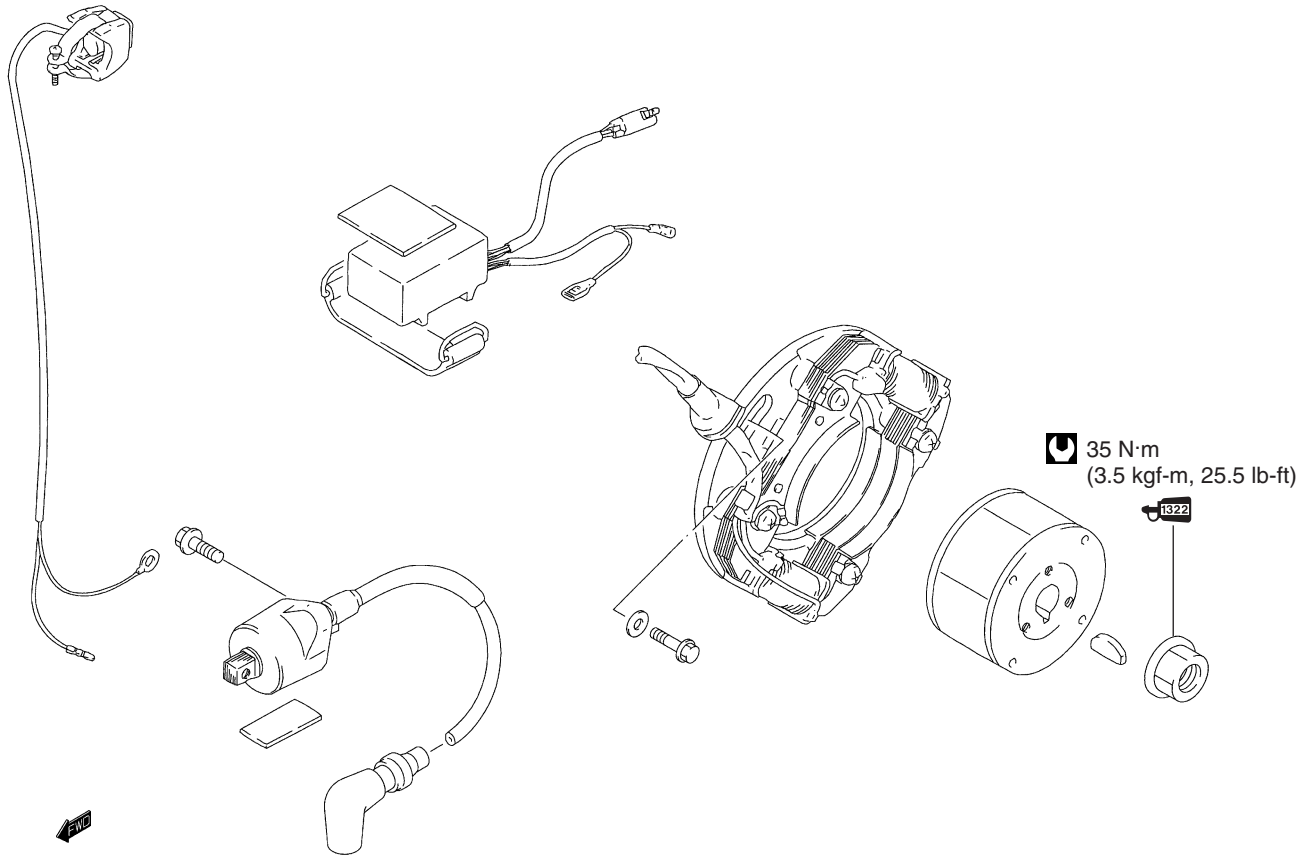

ELECTRICAL CIRCUIT

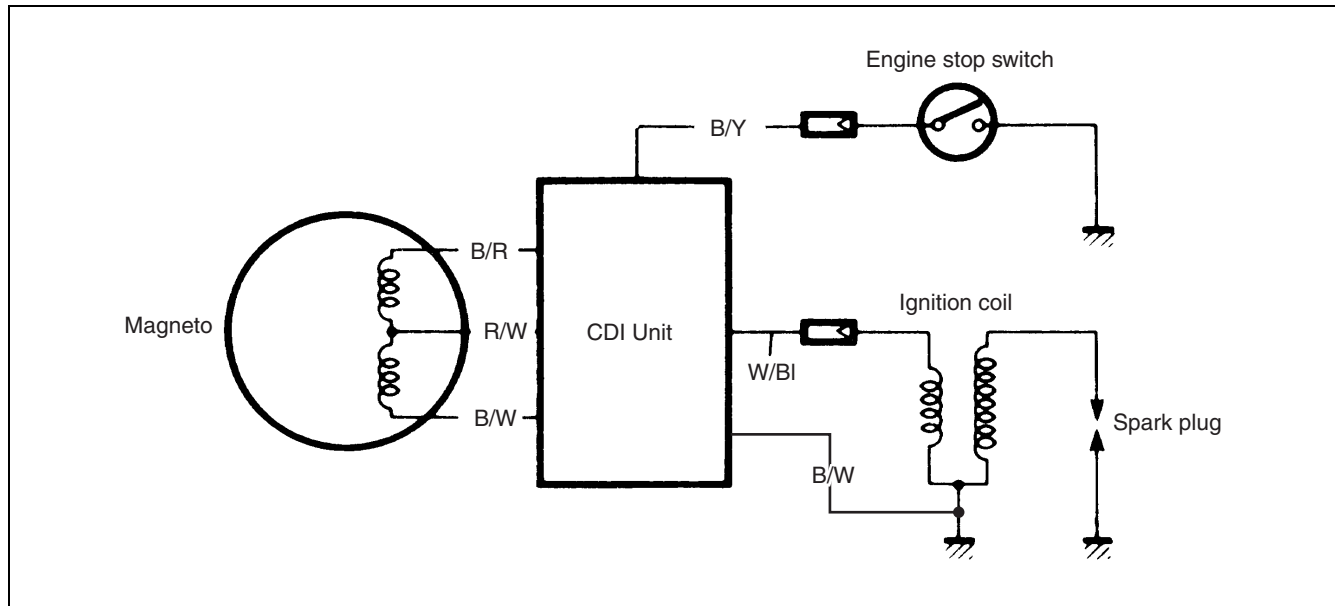

Color code:

B/W : Black with White tracer
 B/R : Black with Red tracer
 R/W : Red with White tracer

B/Y : Black with Yellow tracer
 W/BI : White with Blue tracer

IGNITION SYSTEM

IGNITION SYSTEM PEAK VOLTAGE INSPECTION

- Remove the seat fuel tank. (☞ 5-2)
- Remove the spark plug cap and spark plug.
- Connect a new spark plug to the spark plug cap and ground it to the cylinder head.

NOTE:

Make sure that the spark plug cap and spark plug are connected properly.

Measure ignition coil primary peak voltage using the multi-circuit tester in the following procedure.

- Connect the multi-circuit tester with the peak voltage adaptor as follows.

Ignition coil:

White/Blue terminal – Ground
 (⊖ probe) (⊕ probe)

NOTE:

Do not disconnect the ignition coil primary wire.

 **09900-25008: Multi-circuit tester set**

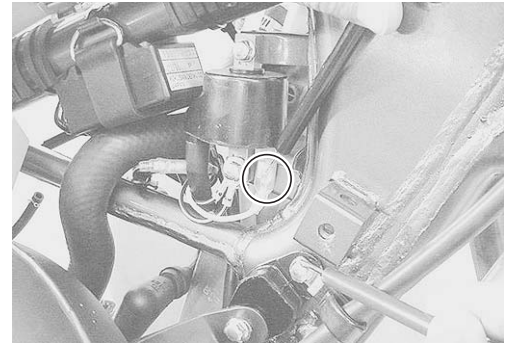

CAUTION

Before using the multi-circuit tester and peak volt adaptor, be sure to refer to the appropriate instruction manual.

- Shift the transmission into neutral, and pull the clutch lever.
- Depress the kick starter lever force fully.
- Repeat the above procedure a few times and measure the highest ignition coil primary peak voltage.

 **Tester knob indication: Voltage (---)**

DATA

White/Blue – Ground	200 V and more
---------------------	----------------

▲ WARNING

While testing, do not touch the tester probes and spark plug to prevent receiving an electric shock.

- If the voltage is lower than the specified values, inspect the ignition coil. (☞ 13-4)

IGNITION COIL INSPECTION

- Remove the seat and fuel tank. (☞ 5-2)
- Measure the ignition coil electrical resistance.

TOOL 09900-25008: Multi-circuit tester
 Tester knob indication: Resistance (W)

DATA

Primary	White/Blue – Ground	0.2 – 1.0 Ω
Secondary	Plug cap – Ground	12 – 20 kΩ

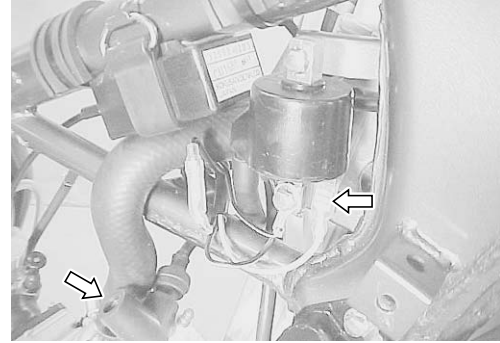

CDI UNIT INSPECTION

- Remove the seat. (☞ 5-2)
- Remove the CDI unit from the frame.
- Measure voltage between the lead wires with the multi-circuit tester as shown in the illustration.

TOOL 09900-25008: Multi-circuit tester
 Tester knob indication: Diode (←→)

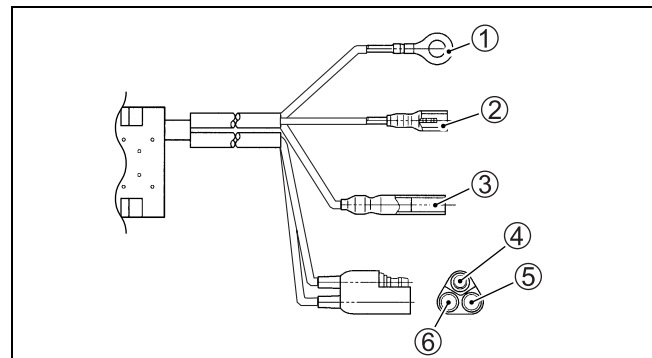
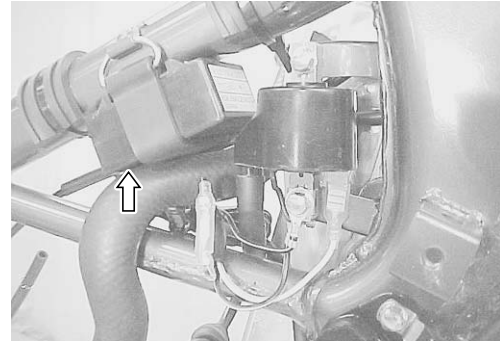

DATA

Unit: V

		Positive ⊕ probe pin (Diode terminal)					
		①	②	③	④	⑤	⑥
Negative ⊖ probe pin (COM terminal)	①	—	0.165 – 0.765	—	—	0.000 – 0.300	—
	②	—	—	—	—	—	—
	③	0.165 – 0.765	0.589 – 1.189	—	0.589 – 1.189	0.165 – 0.765	—
	④	1.211 – 1.511	1.211 – 1.511	1.211 – 1.511	—	1.211 – 1.511	—
	⑤	0.000 – 0.300	0.165 – 0.765	—	—	—	—
	⑥	0.290 – 0.890	0.657 – 1.257	—	—	—	—

NOTE:
 – is open circuit voltage (1.511 V).

STATOR COIL INSPECTION

- Remove the seat and fuel tank. (☞ 5-2)
- Disconnect the magneto lead wire coupler.
- Measure the stator coils electrical resistance.

DATA

Black/Red – Black/White	240 – 380 Ω
Red/White – Black/White	140 – 230 Ω
Black/Red – Red/White	100 – 160 Ω

TOOL 09900-25008: Multi-circuit tester
Tester knob indication: Resistance (Ω)

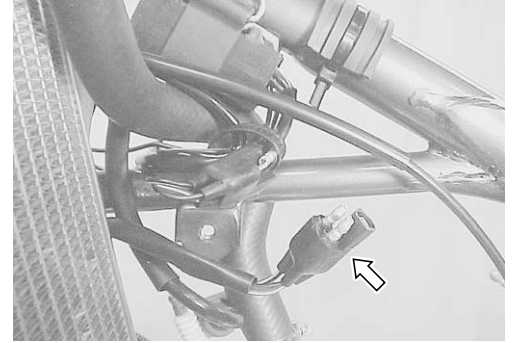

MAGNETO ROTOR AND STATOR REMOVAL AND REASSEMBLY

- Remove the screws and magneto cover.
- Remove the bolts and stator. Disconnect the lead wires.

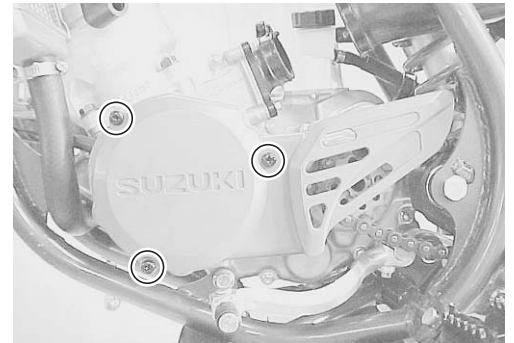

- Remove the cylinder and piston. (☞ 6-3 and -4)
- Hold the conrod with the special tool and loosen the nut.

TOOL 09910-20116: Conrod holder

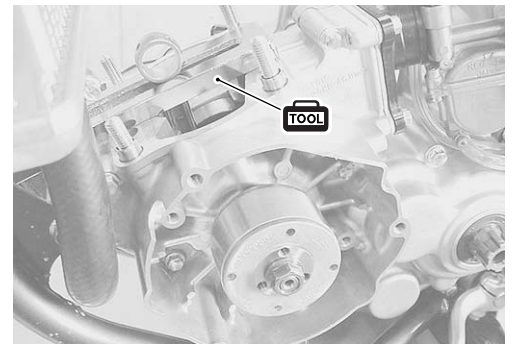

- Remove the magneto rotor with the special tools. Remove the key.

TOOL 09930-30211: Flywheel rotor remover, Attachment $\text{\textcircled{C}}$
09930-30141: Flywheel rotor remover, Attachment $\text{\textcircled{A}}$



MAGNETO ROTOR AND STATOR REASSEMBLY

- Install the key onto the crankshaft.

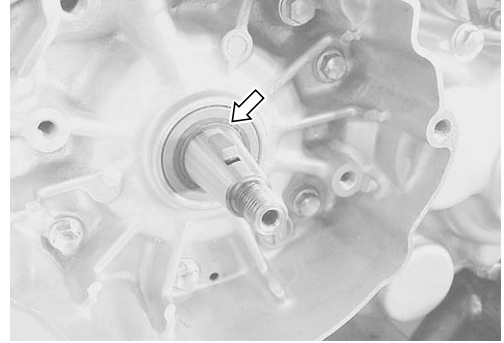

- Install the magneto rotor.
- Hold the conrod with the special tool.
- Apply THREAD LOCK SUPER “1322” to the nut and tighten the nut to the specified torque.

 **09910-20116: Conrod holder**

 **99000-32110: THREAD LOCK SUPER “1322”**

 **Magneto rotor nut: 35 N·m (3.5 kgf-m, 25.5 lb-ft)**

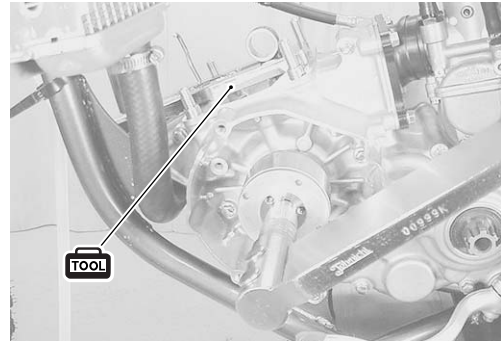

- Align the line on the stator with triangle mark on the crankcase.
- Install the magneto cover.
- Reassemble the piston and cylinder. (☞ 6-8 and -10)



FRONT AND REAR WHEELS

CONTENTS

CONSTRUCTION	14- 2
FRONT AND REAR WHEELS	14- 2
FRONT WHEEL	14- 3
REMOVAL	14- 3
INSPECTION	14- 3
FRONT WHEEL BEARING REMOVAL	14- 4
FRONT WHEEL BEARING REASSEMBLY	14- 4
FRONT WHEEL INSTALLATION	14- 4
REAR WHEEL	14- 5
REMOVAL	14- 5
INSPECTION	14- 5
REAR WHEEL BEARING REMOVAL	14- 6
REAR WHEEL BEARING REASSEMBLY	14- 6
REAR WHEEL INSTALLATION	14- 6
DISC PLATE REPLACEMENT	14- 7
REAR SPROCKET REPLACEMENT	14- 7

CONSTRUCTION FRONT AND REAR WHEELS

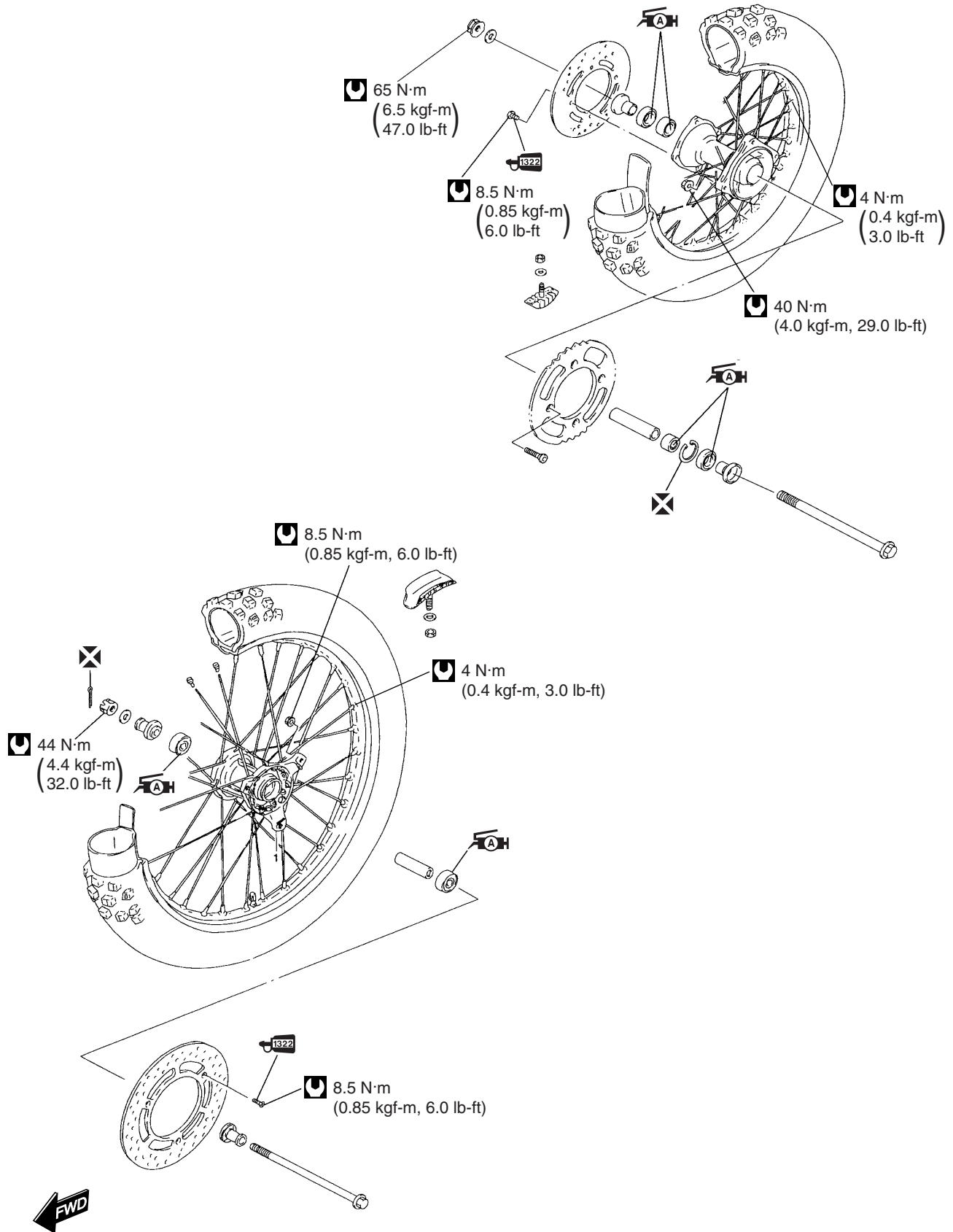

FRONT WHEEL

REMOVAL

- Place the motorcycle on a block to lift front wheel off the ground.
- Remove the cotter pin.
- Loosen the axle nut ①.
- Remove the axle.
- Remove the front wheel and collars.

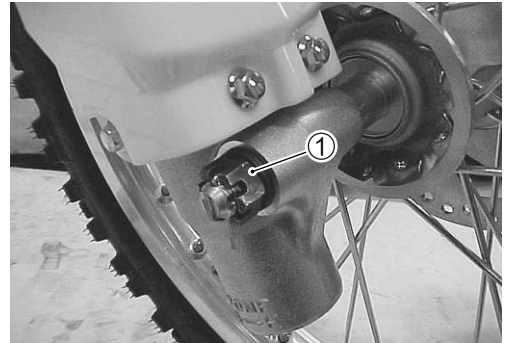

INSPECTION

AXLE SHAFT

- Support the axle shaft with V-blocks and measure the axle shaft runout.

DATA Service Limit: 0.25 mm (0.010 in)

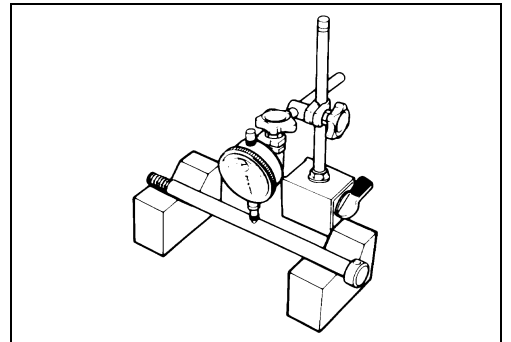

WHEEL RIM

- Measure the wheel rim runout with a dial gauge.

DATA Service Limit: 2.0 mm (0.08 in) ... axial and radial

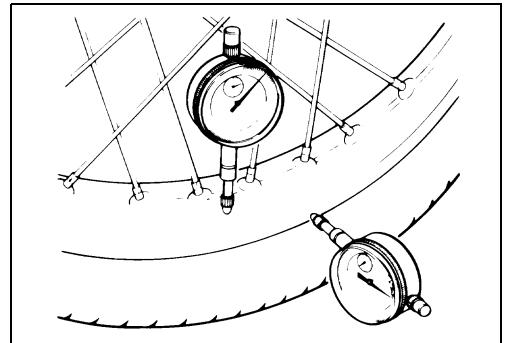

WHEEL BEARING

- Turn the inner race by finger and inspect it for smooth movement.
- Inspect the clearance between the outer race and wheel hub.
- Inspect for bearing damage.

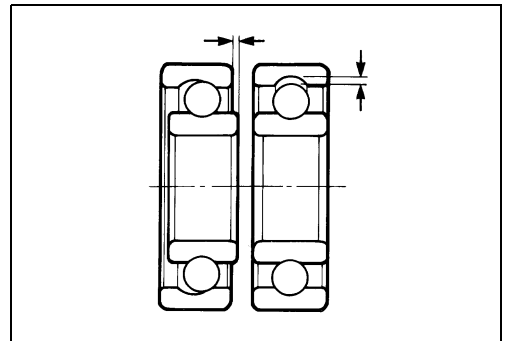

FRONT WHEEL BEARING REMOVAL

- Fit the bearing remover into the wheel bearing.

 **09921-20220: Bearing remover set**

- Remove the bearings and spacer.

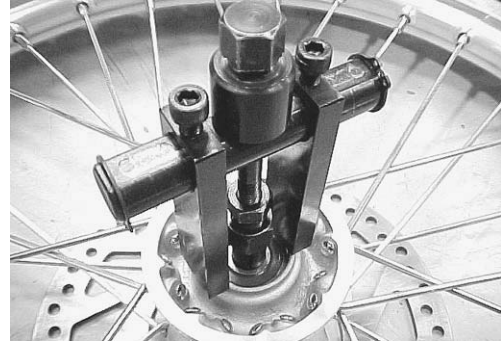

FRONT WHEEL BEARING REASSEMBLY

- Apply grease to the bearings.
- Reassemble the spacer and bearings with the special tool.

 **09941-34513: Bearing installer set**

NOTE:

- * *The sealed cover of the bearing must face outside.*
- * *Reassemble the left side (disc side) bearing first and then reassemble the right side bearing.*
- * *After reassembling the bearings, inspect the bearings for smooth movement.*

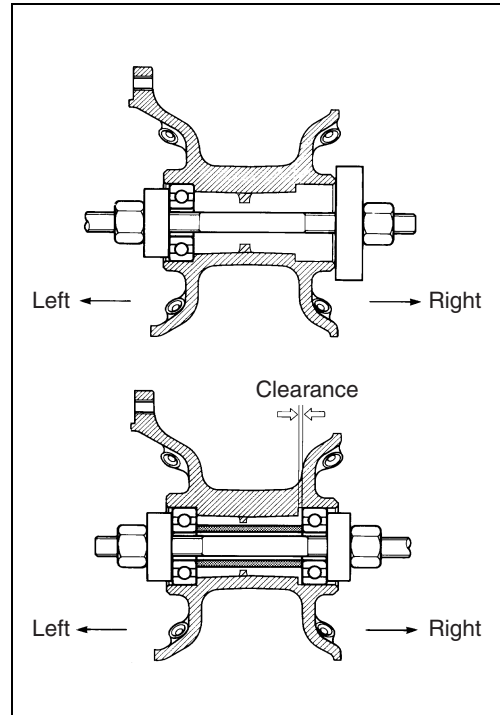

FRONT WHEEL INSTALLATION

- Install the front wheel, axle collars and front axle.
- Tighten the axle nut to the specified torque.

 **Axle nut: 44 N·m (4.4 kgf-m, 32.0 lb-ft)**

- Replace the cotterpin with a new one.

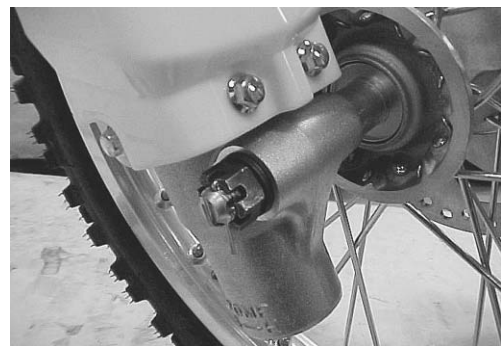

REAR WHEEL REMOVAL

- Place the motorcycle on a block to lift the rear wheel off the ground.
- Remove the axle nut ①.
- Hold the rear wheel and remove the rear axle shaft.
- Remove the rear wheel.

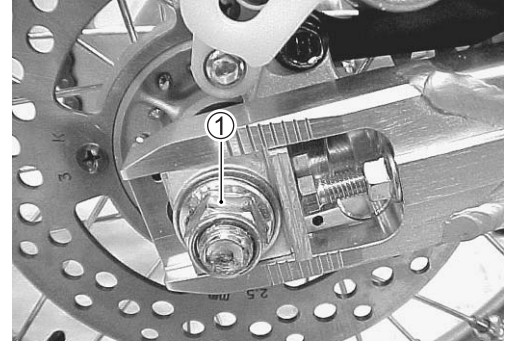

INSPECTION

AXLE SHAFT

- Support the axle shaft with V-blocks and measure the axle shaft runout.

DATA Service Limit: 0.25 mm (0.010 in)

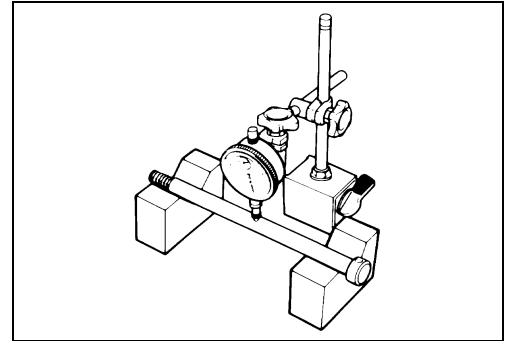

WHEEL RIM

- Measure the wheel rim runout with a dial gauge.

DATA Service Limit: 2.0 mm (0.08 in) ... axial and radial

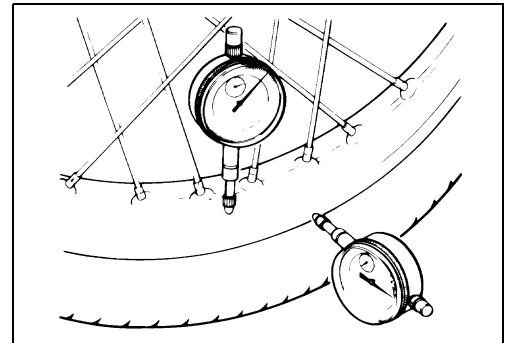

WHEEL BEARING

- Turn the inner race by finger and inspect it for smooth movement.
- Inspect the clearance between the outer race and wheel hub.
- Inspect for bearing damage.

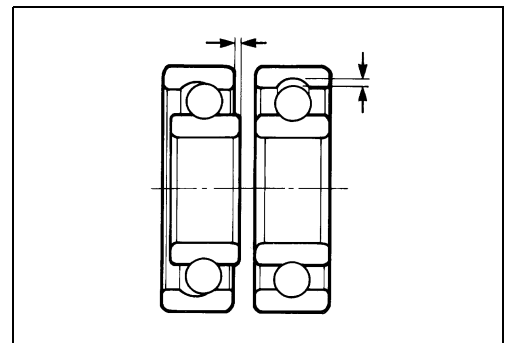

WHEEL SPACER

- Inspect the rear wheel collars and the dust seals for wear and cracks.
- Replace the collars together with the dust seal, if you find excessive wear on the spacer.

NOTE:

Apply grease on the collars and dust seal before reassembling.



REAR WHEEL BEARING REMOVAL

- Remove the dust seals and snap ring from the wheel hub.
- Fit the bearing remover into the wheel bearing.

 **09921-20220: Bearing remover set**

- Remove the bearings and spacer.



REAR WHEEL BEARING REASSEMBLY

- Apply grease to the bearings.
- Reassemble the spacer and bearings with the special tool.

 **09941-34513: Bearing installer set**

NOTE:

After reassembling the bearings, inspect the bearings for smooth movement.

- Install the snap ring ① at the left side (sprocket side).
- Install the dust seals and apply grease to its lips.

NOTE:

- * *The sealed cover of the bearing must face outside.*
- * *Reassemble the left side (sprocket side) bearing first and then reassemble the right side bearing.*

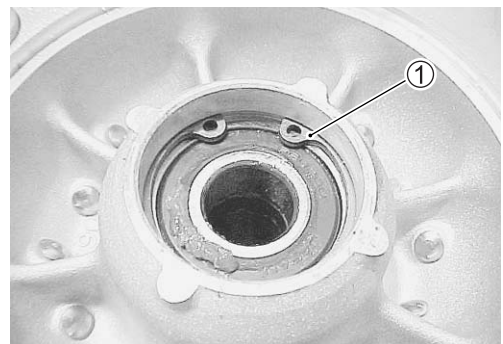
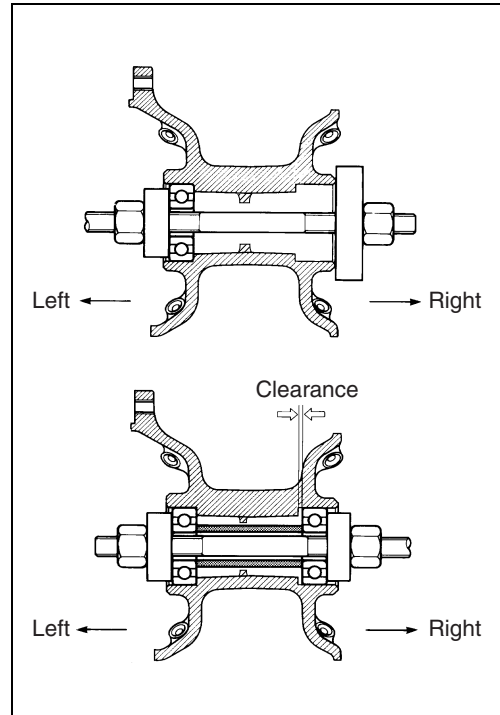

REAR WHEEL INSTALLATION

- Reassemble the rear wheel and axle shaft.
- Adjust the drive chain slack. (➡ 2-13)
- Tighten the axle nut ① to the specified torque.

 **Rear axle nut: 72 N·m (7.2 kgf-m, 52.0 lb-ft)**

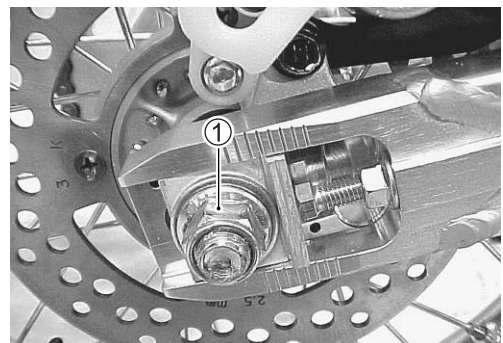

DISC PLATE REPLACEMENT

- Remove the front and rear wheels. (☞ 14-3 and -5)
- Replace the disc.
- Apply THREAD LOCK SUPER “1322” to the screws.

 **99000-32110: THREAD LOCK SUPER “1322”**

- Tighten the screws and nuts ① (front only) to the specified torque.

 **Brake disc screw : 8.5 N·m (0.85 kgf-m, 6.0 lb-ft)**
Front brake disc nut : 8.5 N·m (0.85 kgf-m, 6.0 lb-ft)

NOTE:

When installing the front disc, first tighten the screws to the specified torque, and then tighten the nuts ① to the specified torque.

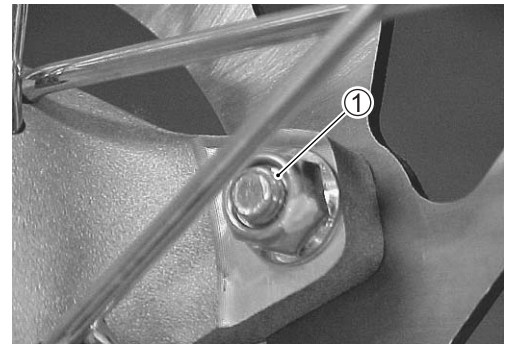
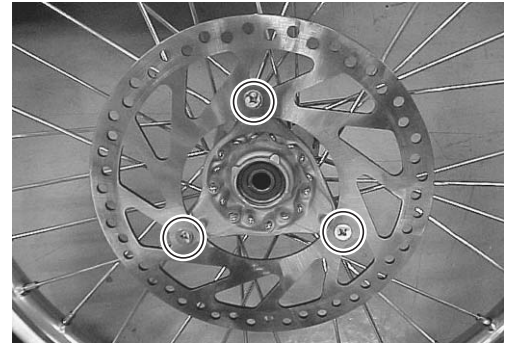

REAR SPROCKET REPLACEMENT

- Remove the rear wheel. (☞ 14-5)
- Replace the rear sprocket.
- Tighten the nuts to the specified torque.

 **Rear sprocket nut: 40 N·m (4.0 kgf-m, 29.0 lb-ft)**

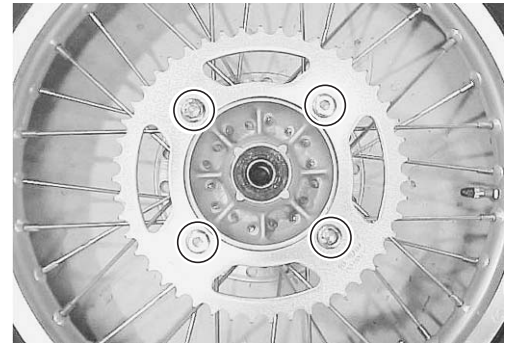

- MEMO -

FRONT AND REAR BRAKES

CONTENTS

CONSTRUCTION	15- 2
FRONT AND REAR BRAKES	15- 2
BRAKE FLUID	15- 3
BRAKE FLUID AIR BLEEDING	15- 3
BRAKE FLUID REPLACEMENT	15- 4
BRAKE PAD REPLACEMENT	15- 4
BRAKE DISC	15- 5
BRAKE DISC INSPECTION	15- 5
BRAKE DISC REPLACEMENT	15- 5
BRAKE CALIPER	15- 6
FRONT CALIPER REMOVAL AND DISASSEMBLY	15- 6
REAR CALIPER REMOVAL AND DISASSEMBLY	15- 7
CALIPER INSPECTION	15- 8
CALIPER CLEANING	15- 8
FRONT CALIPER REASSEMBLY	15- 9
REAR CALIPER REASSEMBLY	15- 9
MASTER CYLINDER	15-10
FRONT MASTER CYLINDER REMOVAL AND DISASSEMBLY	15-10
REAR MASTER CYLINDER REMOVAL AND DISASSEMBLY	15-11
MASTER CYLINDER INSPECTION	15-12
MASTER CYLINDER CLEANING	15-12
FRONT MASTER CYLINDER REASSEMBLY	15-12
REAR MASTER CYLINDER REASSEMBLY	15-13
BRAKE PEDAL	15-14
BRAKE PEDAL REMOVAL AND REASSEMBLY	15-14

CONSTRUCTION FRONT AND REAR BRAKES

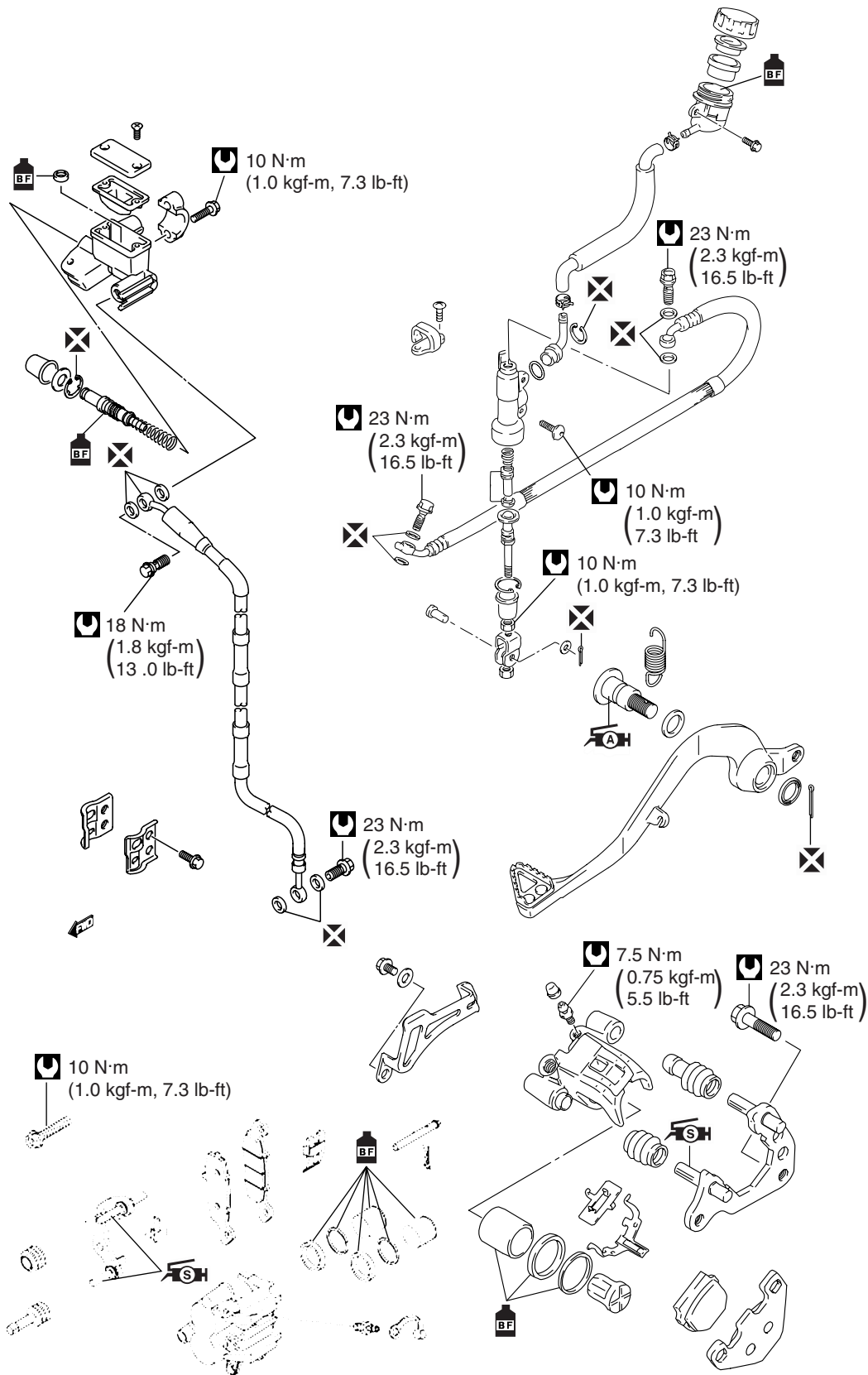

BRAKE FLUID

BRAKE FLUID AIR BLEEDING

⚠ WARNING

Brake fluid can be hazardous to humans and pets. Brake fluid is harmful or fatal if swallowed, and harmful if it comes in contact with your skin or eyes.

Keep brake fluid away from children. Call your doctor immediately if brake fluid is swallowed and induce vomiting. Flush eyes or skin with water if brake fluid gets in eyes or comes in contact with skin.

⚠ WARNING

The use of any fluid except DOT 4 brake fluid from a sealed container can damage the brake system and lead to an accident.

Use only DOT 4 brake fluid from sealed container. Never use or mix different types of brake fluid.

CAUTION

Spilled brake fluid can damage painted surfaces and plastic parts.

Be careful not to spill any brake fluid when servicing brake fluid. Wipe spilled fluid up immediately.

- Remove the reservoir cap.
- Connect a transparent tube to the bleeder valve and set the other end into a receptacle.
- Pour brake fluid up to the UPPER line.
- Pump the brake lever/pedal until air bubbles stop coming out from the reservoir.
- Hold the brake lever/pedal in the squeezed position.
- Open the bleeder valve and tighten the bleeder valve.
- Release the brake lever/pedal.
- Repeat this sequence until air bubbles stop coming out from the bleeder valve.

NOTE:

Do not release the brake lever/pedal while the bleeder valve is opened.

- Replenish brake fluid to the UPPER line when the brake fluid level drops below LOWER line.

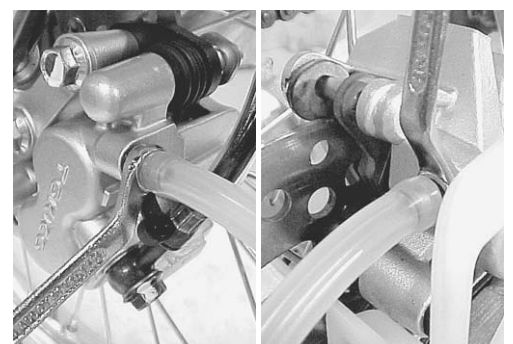
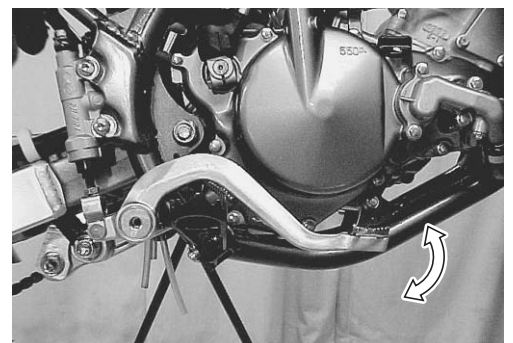
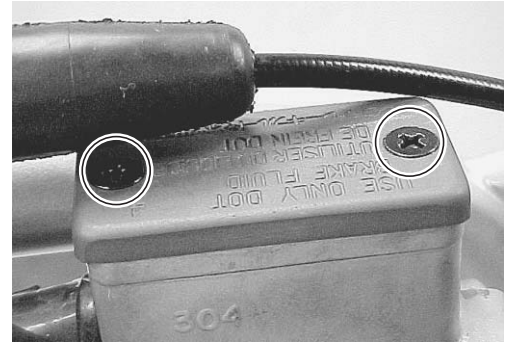

- Tighten the air bleeder valve.

Brake caliper air bleeder valve:

7.5 N·m (0.75 kgf-m, 5.5 lb-ft)



- Pour brake fluid up to the UPPER line.
- Reassemble the reservoir cap.

BRAKE FLUID REPLACEMENT

- Remove the reservoir cap.
- Connect a transparent tube to the bleeder valve and set the other end into a receptacle.
- Loosen the bleeder valve and pump the brake lever/pedal until brake fluid stops coming out from the bleeder valve.
- Pour brake fluid into the reservoir.
- Bleed air from the brake system. ( 15-3)
- Reassemble the reservoir cap.

BRAKE PAD REPLACEMENT

FRONT BRAKE PAD

- Remove the caliper mounting bolts.
- Remove the brake pads by removing the clip  and pad mounting pin .

NOTE:

Replace the two brake pads as a set.

- Install the new brake pads to the caliper.

NOTE:

When installing the inner pad, seat it on the hating part  of the pad spring.

- Tighten the caliper mounting bolts.

Caliper mounting bolt: 23 N·m (2.3 kgf-m, 16.5 lb-ft)

NOTE:

Pump the brake lever several times to seat the brake pads after reassembling.

REAR BRAKE PAD

- Remove the caliper mounting bolts.

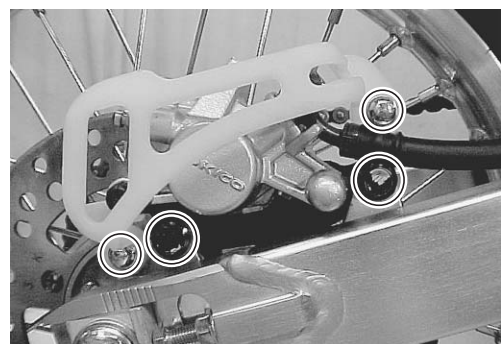
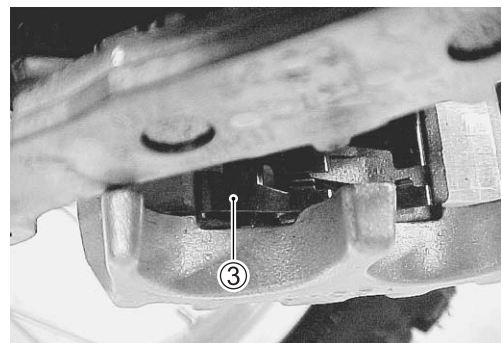
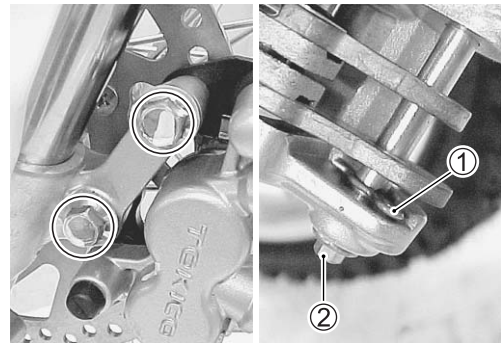

- Remove the clamp ①. Remove the pad mounting pin ②.

NOTE:

Replace the two pads as a set.

- Install the new brake pads to the caliper.

NOTE:

Make sure that the tip **A** of the spring is fitted to the inner pad ③.

- Tighten the caliper mounting bolts.

🔧 Caliper mounting bolt: 23 N·m (2.3 kgf-m, 16.5 lb-ft)

NOTE:

Pump the brake pedal several times to seat the brake pads after reassembling.

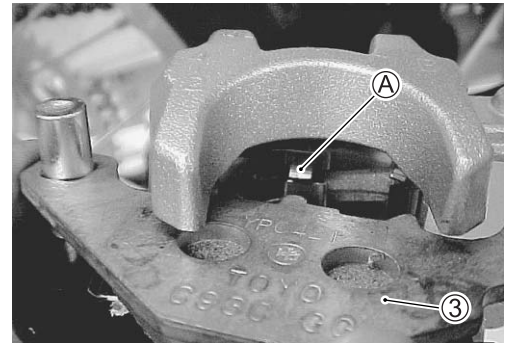
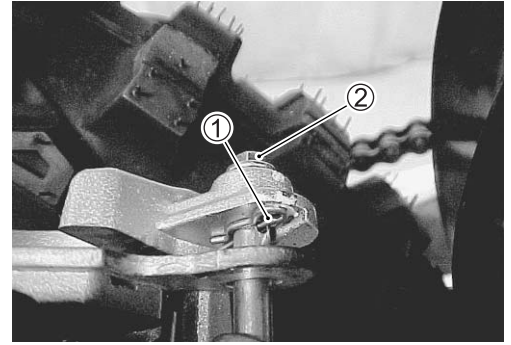

BRAKE DISC

BRAKE DISC INSPECTION

- Measure the front and rear brake disc thickness.

DATA Service Limit: 2.5 mm (0.10 in)

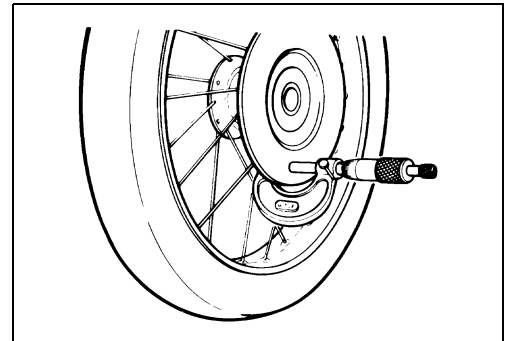

- Measure the front and rear brake disc runout.

DATA Service Limit: 0.30 mm (0.01 in)

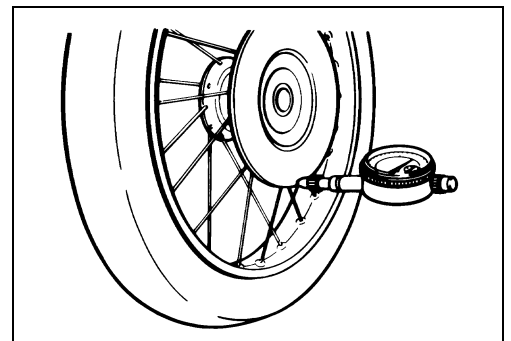

BRAKE DISC REPLACEMENT

(👉 14-7)

BRAKE CALIPER

⚠ WARNING

The use of any brake fluid except DOT 4 brake fluid from a sealed container can damage the brake system and lead to an accident.

Use only DOT 4 brake fluid from a sealed container. Never use or mix different types of brake fluid.

⚠ WARNING

Brake fluid can be hazardous to humans and pets. Brake fluid is harmful or fatal if swallowed, and harmful if it comes in contact with your skin or eyes.

Keep brake fluid away from children. Call your doctor immediately if brake fluid is swallowed, and induce vomiting. Flush eyes or skin with water if brake fluid gets in eyes or comes in contact with skin.

CAUTION

Spilled brake fluid can damage painted surfaces and plastic parts.

Be careful not to spill any fluid when servicing the caliper. Wipe spilled fluid up immediately.

FRONT CALIPER REMOVAL AND DISASSEMBLY

- Drain brake fluid. (☞ 15-4)
- Place a drain pan under the caliper and remove the union bolt ①.
- Remove the caliper mounting bolts ②.
- Remove the brake pads and spring ③ from the caliper.
- Remove the caliper bracket ④ from the caliper.
- Wrap the caliper with a rag to prevent brake fluid scatter and piston pop-out.

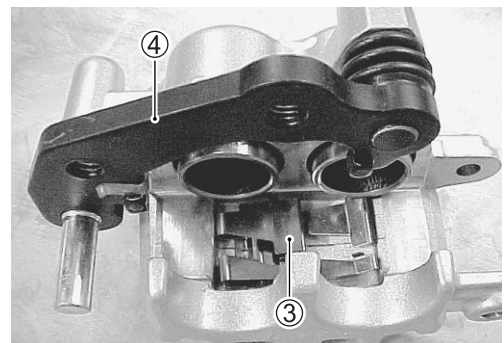
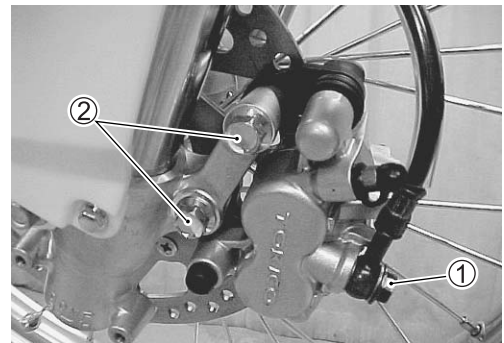

- Apply low-pressure air into the caliper through the hole to remove the piston.

⚠ WARNING

Fingers can get caught between piston and caliper body when removing the piston.

Do not place your fingers on the piston when removing the piston.

- Remove the piston seal ① and dust seal ②.

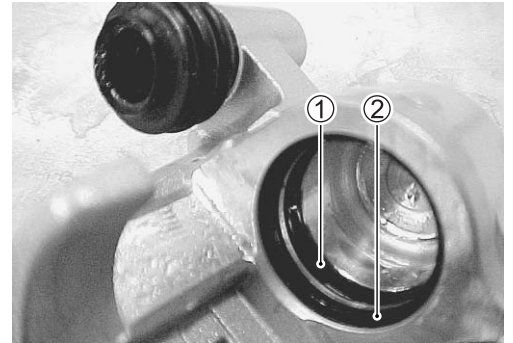
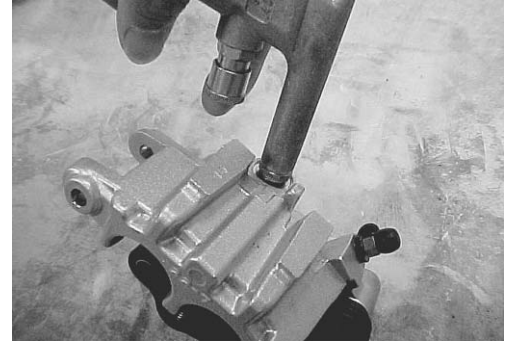

REAR CALIPER REMOVAL AND DISASSEMBLY

- Drain brake fluid. (☞ 15-4)
- Place a rag under the brake hose union bolt to catch spilled brake fluid.
- Remove the caliper mounting bolts ① and, disconnect the brake hose ②.

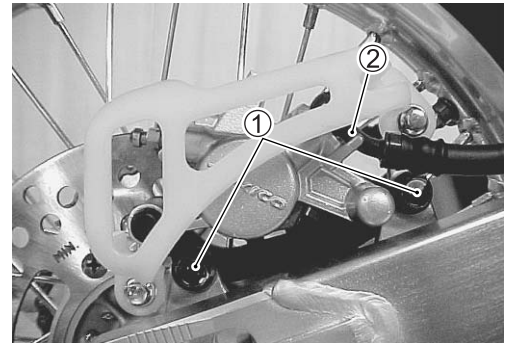

- Remove the brake pads and spring ③ from the caliper.
- Remove the caliper bracket ④.
- Wrap the caliper with a rag to prevent brake fluid scatter and piston pop-out.
- Apply low-pressure air into the caliper through the hole to remove the piston.

▲ WARNING

Fingers can get caught between piston and caliper body when removing the piston.

Do not place your fingers on the piston when removing the piston.

- Remove the piston seal ⑤ and dust seal ⑥.

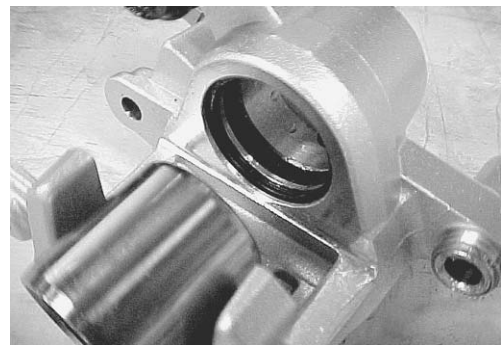
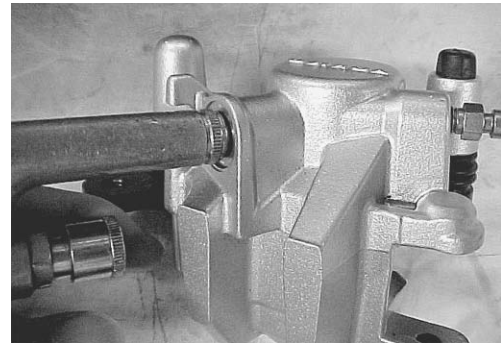
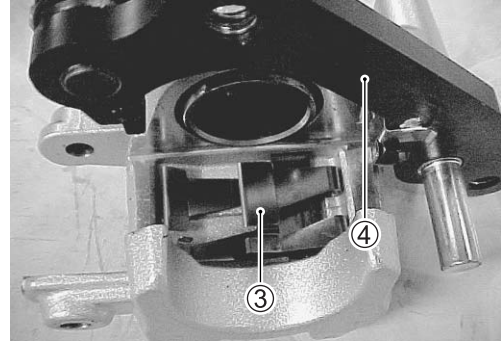

CALIPER INSPECTION

- Inspect the caliper cylinder wall and piston surface for scratch, corrosion or other damages. If any abnormal condition is noted, replace the caliper.
- Inspect the rubber parts. If any damages are found, replace it with a new one.

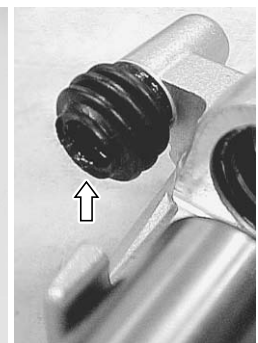

CALIPER CLEANING

- Flush the caliper ports with pressurized air.
- Wash the caliper piston and cylinder with fresh brake fluid.

NOTE:

Do not use gasoline or other cleaning solvents to wash the caliper parts.

 **Brake fluid: DOT 4**

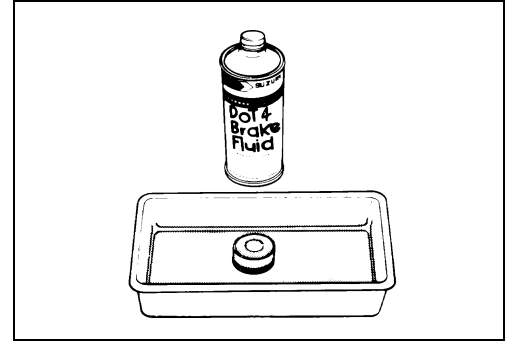

FRONT CALIPER REASSEMBLY

- Apply brake fluid to the piston seal ① and dust seal ②, then install them to the caliper.
- Install the piston into the caliper.
- Apply silicone grease to the caliper axles.

99000-25100: SUZUKI SILICONE GREASE

- Install the boots and caliper bracket.
- Install the spring and brake pads. ( 15-4)
- Tighten the caliper mounting bolts to the specified torque.

Caliper mounting bolt: 23 N·m (2.3 kgf-m, 16.5 lb-ft)

- Tighten the brake hose union bolt to the specified torque.

Brake hose union bolt: 23 N·m (2.3 kgf-m, 16.5 lb-ft)

- Refill brake fluid and bleed air from the brake system. ( 15-4)

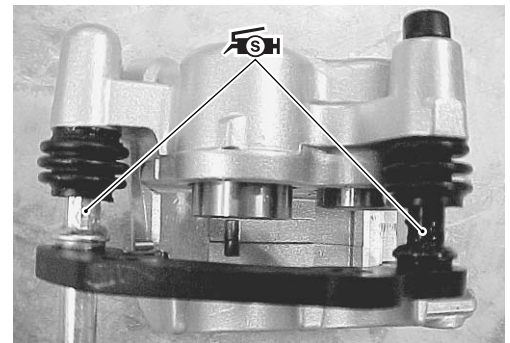
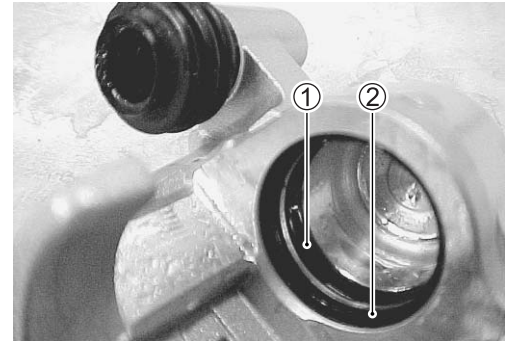

REAR CALIPER REASSEMBLY

- Apply brake fluid to the piston seal ① and dust seal ②, then install them to the caliper.
- Install the piston into the caliper.
- Apply silicone grease to the caliper axles.

99000-25100: SUZUKI SILICONE GREASE

- Install the boots and caliper bracket.
- Install the spring and pads. ( 15-5)
- Tighten the caliper mounting bolts and the brake hose union bolt.

Caliper mounting bolt: 23 N·m (2.3 kgf-m, 16.5 lb-ft)

Brake hose union bolt: 23 N·m (2.3 kgf-m, 16.5 lb-ft)

- Refill brake fluid and bleed air from the brake system. ( 15-3 and -4)

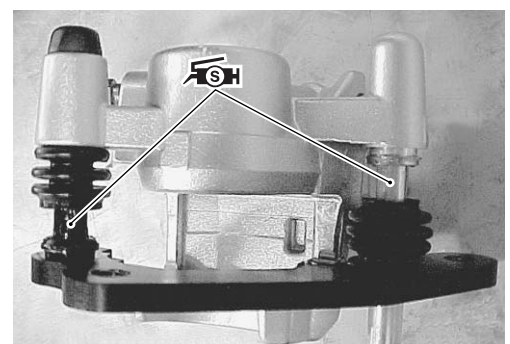
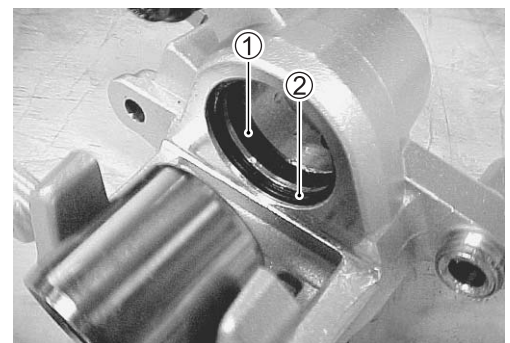

MASTER CYLINDER

⚠ WARNING

Brake fluid can be hazardous to humans and pets. Brake fluid is harmful or fatal if swallowed, and harmful if it comes in contact with your skin or eyes.

Keep brake fluid away from children. Call your doctor immediately if brake fluid is swallowed, and induce vomiting. Flush eyes or skin with water if brake fluid gets in eyes or comes in contact with skin.

⚠ WARNING

The use of any fluid except DOT 4 brake fluid from a sealed container can damage the brake system and lead to an accident.

Use only DOT 4 brake fluid from a sealed container. Never use or mix different types of brake fluid.

CAUTION

Spilled brake fluid can damage painted surfaces and plastic parts.

Be careful not to spill any fluid when filling the brake fluid reservoir. Wipe spilled fluid up immediately.

FRONT MASTER CYLINDER REMOVAL AND DISASSEMBLY

- Drain brake fluid. (➡ 15-4)
- Loosen the brake hose adaptor and disconnect the brake hose.
- Remove the master cylinder holder bolts.

NOTE:

Hold the brake hose with a wrench to prevent the brake from twisting when loosening the adaptor.

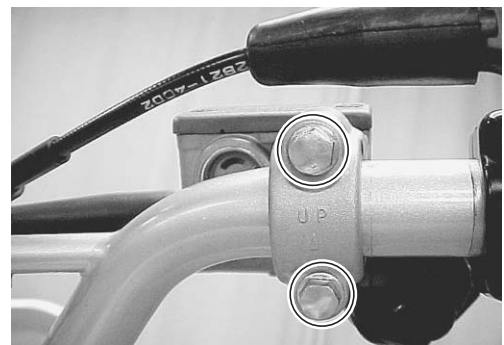
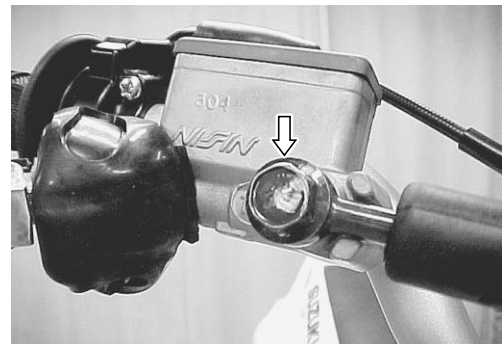

- Remove the bolt ① and brake lever ②.

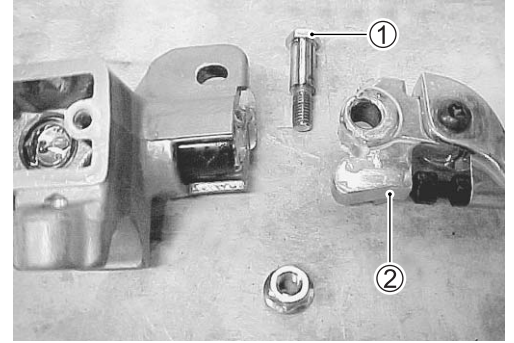

- Remove the dust boot ①.
- Remove the snap ring ② with snap ring pliers.
- Remove the washer ③, piston/cup set ④ and spring ⑤.

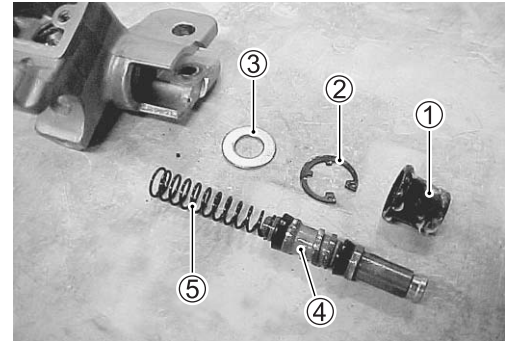

REAR MASTER CYLINDER REMOVAL AND DISASSEMBLY

- Drain brake fluid. (☞ 15-4)
- Remove the rear brake pedal. (☞ 15-14)
- Place a rag under the hose to catch spilled brake fluid.
- Remove the union bolt ①.
- Remove the master cylinder mounting bolts ②.
- Remove the clamp and disconnect the hose (reservoir).
- Remove the dust seal boot ③.
- Remove the snap rings ④ with snap ring pliers.
- Remove the push rod ⑤.
- Remove the piston/cup set ⑥ and spring ⑦.
- Remove the connector ⑧.

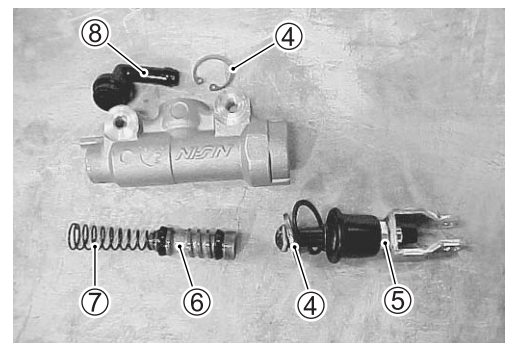
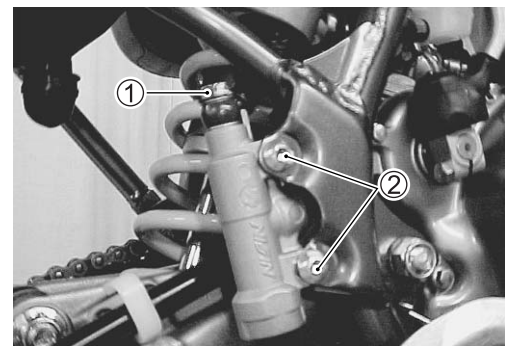

MASTER CYLINDER INSPECTION

- Inspect the cylinder bore and piston for scuffing.
- Inspect the piston rod and spring for damage. If any abnormal condition is noted, replace the master cylinder.
- Inspect the dust boot, if any damages are found, replace it with a new one.

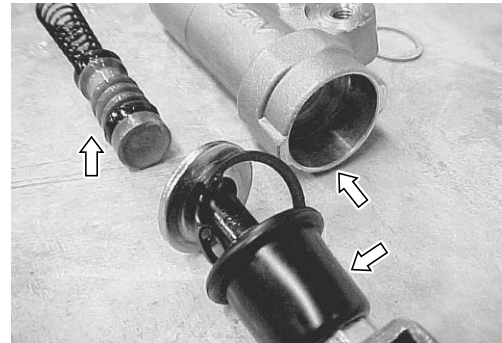
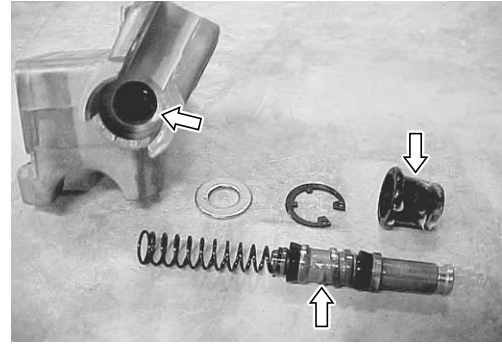

MASTER CYLINDER CLEANING

- Flush the master cylinder ports with pressurized air.
- Wash the master cylinder bore and piston with fresh brake fluid.

NOTE:

Do not use gasoline or other cleaning solvents to wash the master cylinder parts.

 **Brake fluid: DOT 4**

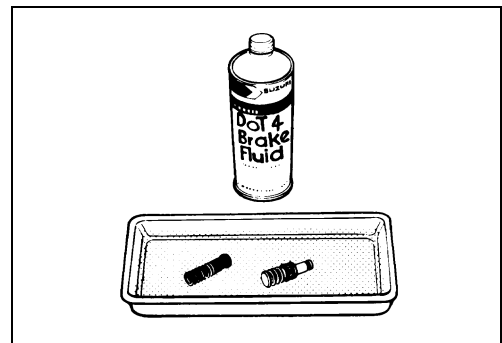

FRONT MASTER CYLINDER REASSEMBLY

- Apply brake fluid to the piston/cup set.
- Install the spring, piston/cup set and washer.
- Install the snap ring with snap ring pliers.
- Install the dust boot.
- Reassemble the brake lever.
- Tighten the master cylinder mounting bolts to the specified torque.
- When remounting the master cylinder on the handlebars, set the brake lever at an angle of 30 degrees to horizon and tighten the upper clamp bolt first as shown to the specified torque.

 **Master cylinder clamp bolt: 10 N·m (1.0 kgf·m, 7.3 lb·ft)**

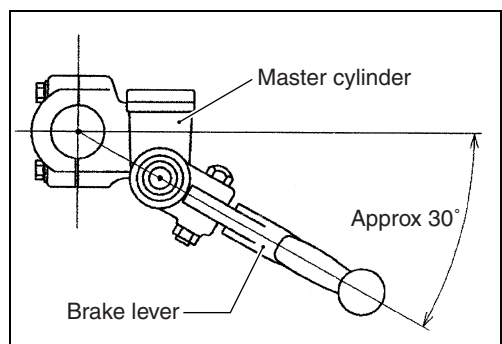
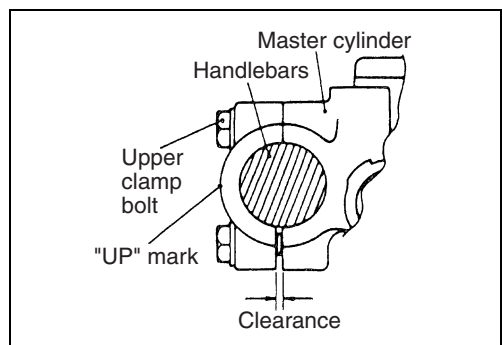

- Tighten the brake hose adaptor ① to the specified torque.

 **Brake hose adaptor: 18 N·m (1.8 kgf·m, 13.0 lb-ft)**

NOTE:

Hold the brake hose with a wrench to prevent the brake hose from twisting when tightening the adaptor.

- Refill brake fluid and bleed air from the brake system.
( 15-3)

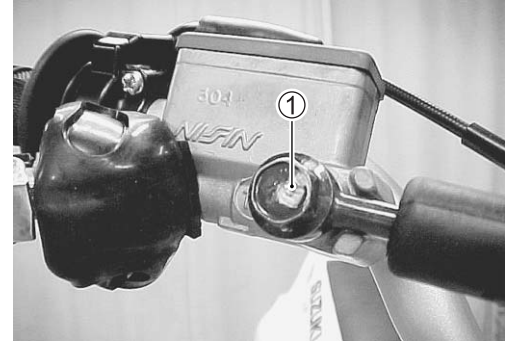

REAR MASTER CYLINDER REASSEMBLY

- Apply brake fluid to the piston/cup and O-ring.
- Install the spring, piston/cup set and push rod.
- Install the connector and O-ring.
- Install the snap rings with snap ring pliers.
- Install the boot.
- Connect the reservoir hose to the connector and clamp it.
- Apply THREAD LOCK SUPER “1322” to the master cylinder mounting bolts.

 **99000-32110: THREAD LOCK SUPER “1322”**

- Tighten the master cylinder mounting bolts to the specified torque.

 **Master cylinder mounting bolt:**

10 N·m (1.0 kgf·m, 7.3 lb-ft)

- Reassemble the rear brake pedal. ( 15-14)
- Tighten the brake hose union bolt to the specified torque.

 **Brake hose union bolt: 23 N·m (2.3 kgf·m, 16.5 lb-ft)**

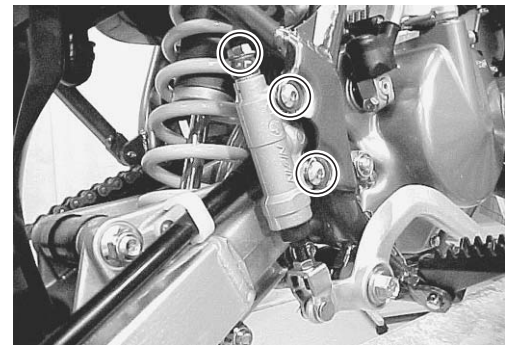
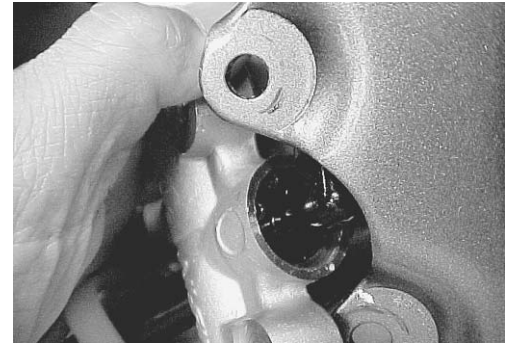

CAUTION

Improper brake hose routing can damage the brake hose.

Set the brake hose so it touches the stopper and tighten the union bolt. Ensure the brake hose has enough clearance to the rear suspension spring.

(Brake hose routing:  18-13)

- Refill brake fluid and bleed air from the brake system.
( 15-3)

BRAKE PEDAL

BRAKE PEDAL REMOVAL AND REASSEMBLY

REMOVAL

- Remove the nut from the brake pedal pivot.
- Remove the cotter pin and pin from the push rod end.
- Remove the return spring.

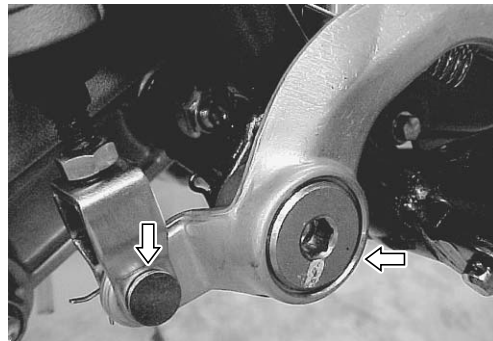

REASSEMBLY

- Reassemble the pin, washer and cotter pin to the push rod end.
- Install the return spring.
- Apply grease to the brake pedal pivot shaft.
- Install the washer and cotter pin.

NOTE:

Replace the cotter pin with new one.

- Adjust the brake pedal height. (☞ 2-17)

FRONT FORK AND STEERING

CONTENTS

CONSTRUCTION	16- 2
FRONT FORK AND STEERING	16- 2
FRONT FORK	16- 3
REMOVAL	16- 3
DISASSEMBLY	16- 3
INSPECTION	16- 5
REASSEMBLY	16- 7
REINSTALLATION	16-11
STEERING	16-12
REMOVAL	16-12
INSPECTION	16-13
BEARING REPLACEMENT	16-13
REASSEMBLY	16-14

CONSTRUCTION FRONT FORK AND STEERING

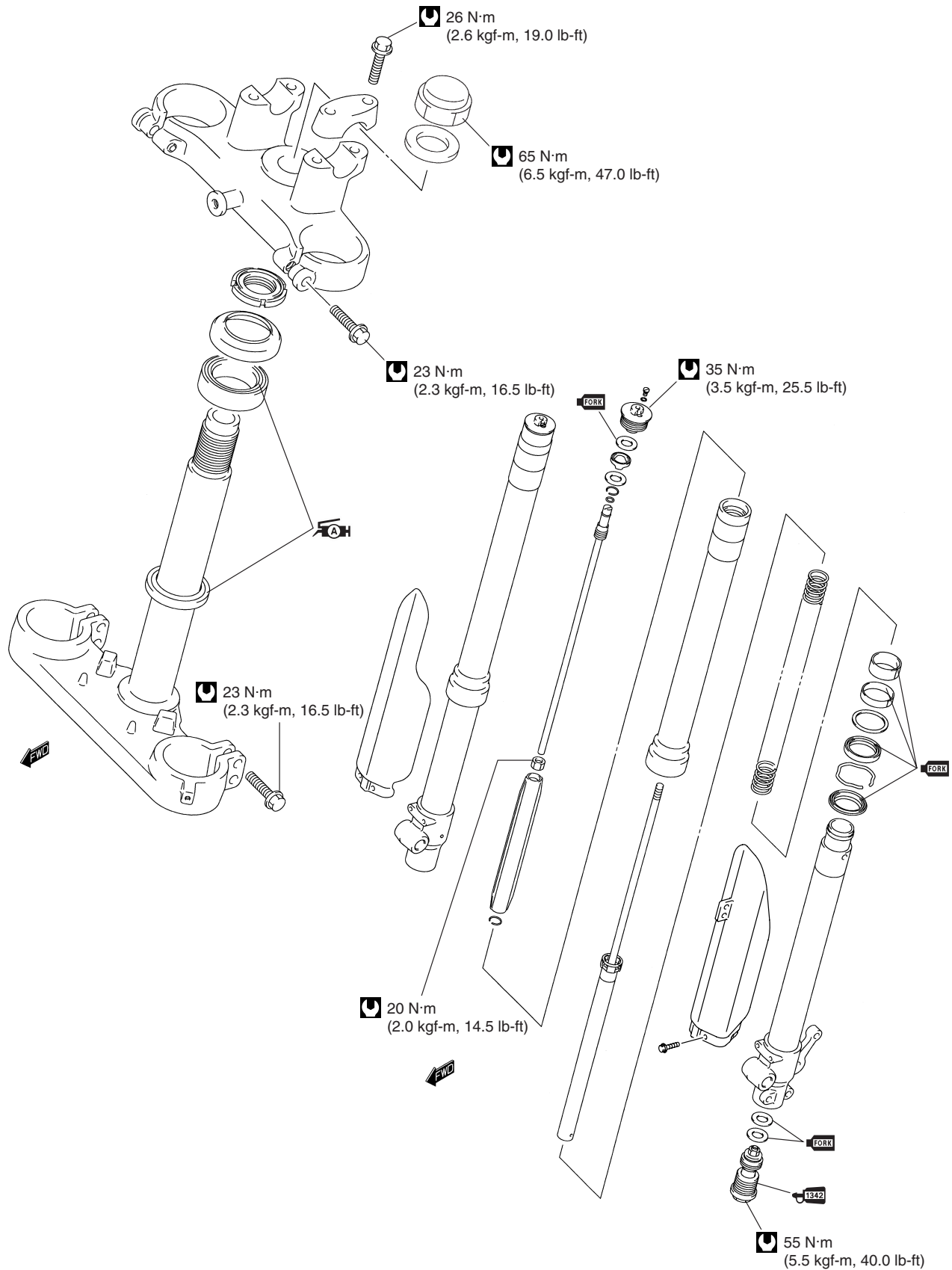

FRONT FORK REMOVAL

- Place a block under the chassis tubes.
- Remove the fork covers, brake hose guide and brake hose cover.
- Remove the brake caliper. (☞ 15-6)
- Remove the front wheel. (☞ 14-3)
- Loosen the fork upper clamp bolts ①.
- Loosen the front fork cap bolt ② 1 – 2 turns to facilitate later disassembly.
- Hold the fork body and loosen the fork lower clamp bolts ③.
- Remove the front forks.

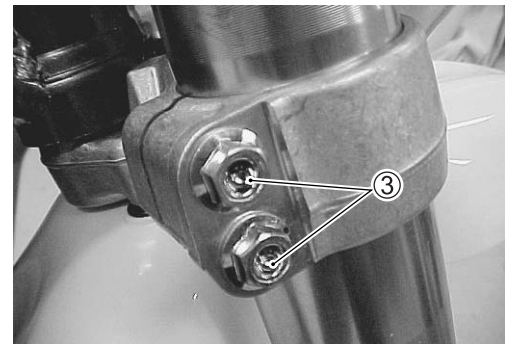
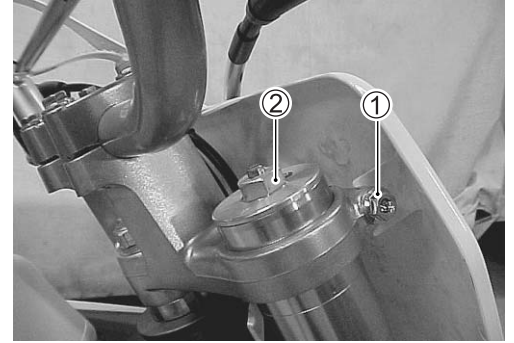

DISASSEMBLY

NOTE:

Set rebound damping adjuster to the softest settings before disassembling. Record the setting before turning the adjuster.

- Thoroughly clean the fork before disassembly.

CAUTION

Scratches or other damage on the inner tube or on the oil seal lip will cause oil leak.

Avoid scratching or damaging the inner tube or the oil seal. Use a mild detergent or car wash soap and sponge out dirt with plenty of water.

- Compress the front fork spring ③ and loosen the lock-nut ①.
- Remove the fork cap ②.
- Remove the fork spring ③.

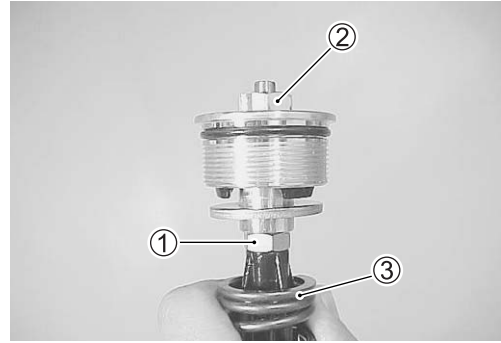

- Remove the lock-nut ④ and the spring guide ⑤.

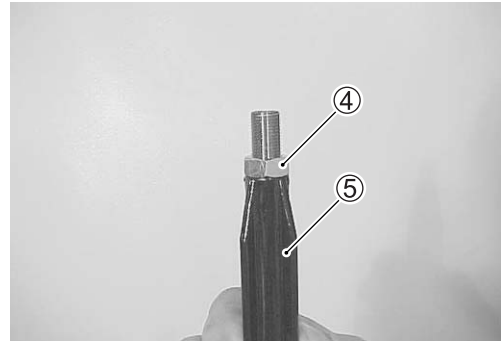

- Invert the front fork and stroke the inner rod several times to let out fork oil.
- Under the inverted condition of front fork, drain oil to hold it for a few time.

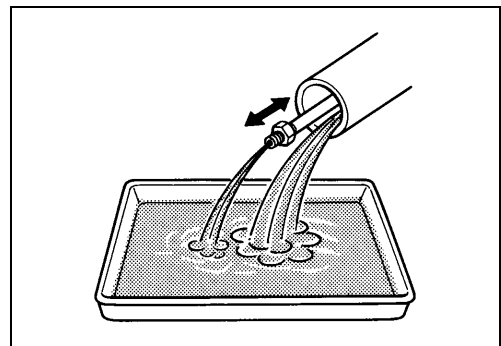

- Remove the damper rod bolt with the special tool.

TOOL 09940-30250: Front fork assembling tool

- Remove the damper.

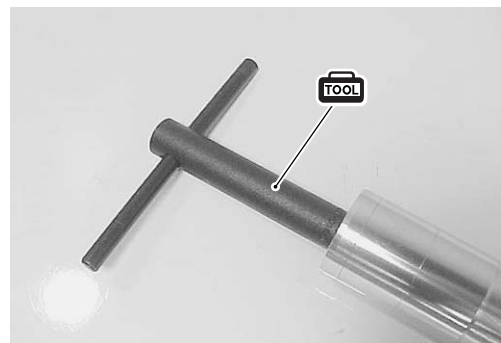

CAUTION

Do not disassemble the damper rod assembly. Disassembling the damper rod assembly can lead to trouble.

- Remove the dust seal ① and the stopper ring ②.

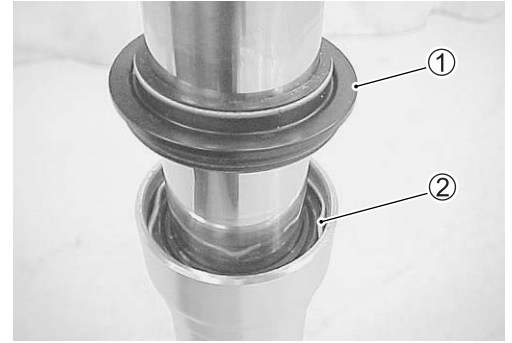

- Pull out the inner tube from the outer tube.

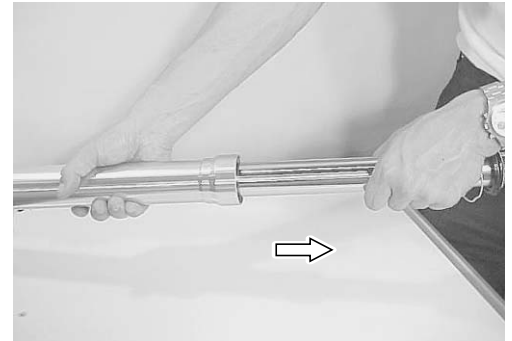

- Remove the slide bushing ③ from the inner tube.

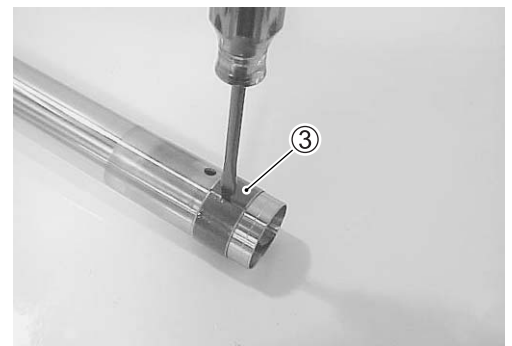

- Remove the following parts from the inner tube.

- Slide bushing ③
- Seal retainer ④
- Oil seal ⑤
- Stopper ring ⑥
- Dust seal ⑦

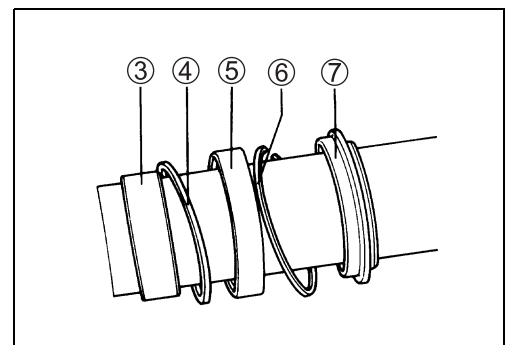

INSPECTION

- Inspect the cylinder bolt for damage. If it is damaged, replace it with a new one.
- Replace the O-ring with a new one.



- Inspect the inner tube for scratches. If it has scratches, replace it with a new one.
- Inspect the outer tube for dent. If it is dented all the way to the inner side, replace it with a new one.

- Inspect the damper rod assembly for scratches or bending. If it has scratches or is bent, replace it with a new one.



- Measure the free length of front fork spring.

DATA Service Limit (Standard spring): 444 mm (17.48 in)

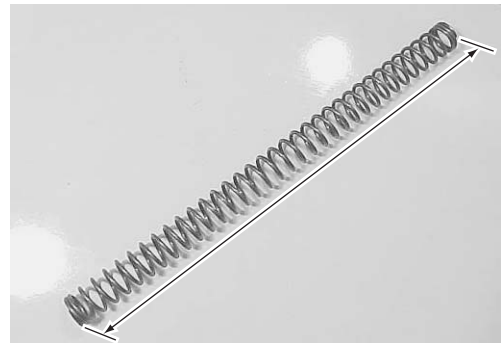

Inspect the “teflon coating metals” (slide bushing and guide bushing) for wear or damage. If they are worn or damaged, replace them with new ones.

Inspect the metal particles on the “teflon coating metals”. If they are not clean, clean them with a nylon brush and fork oil.



REASSEMBLY

NOTE:

- * Clean all fork parts before reassembling.
- * Replace the O-rings, oil seal and dust seal with the new ones.
- * Apply specified front fork oil when installing the O-rings, slide bushing, guide bushing, damper unit and other sliding parts.

- Apply front fork oil to the oil seal lip and the dust seal.
- Cover the inner tube with a vinyl film.
- Install the dust seal ①, stopper ring ② and oil seal ③ onto the inner tube.

CAUTION

Scratches on the oil seal lip can cause oil leaks.

When installing the seal, place a vinyl film over the bushing attachment groove and edges of the inner tube to avoid damage to the seal lip.

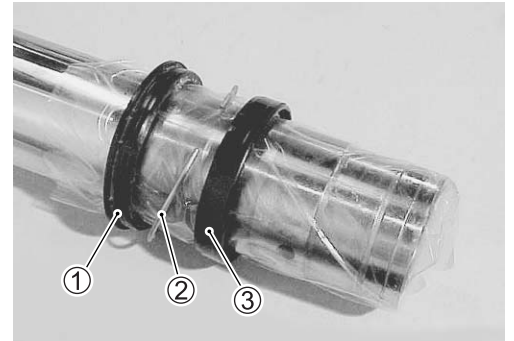

NOTE:

The side of the oil seal that has a mark should face the dust seal.

- Remove the vinyl film and then install the seal retainer ④, guide bushing ⑤ and slide bushing ⑥.
- Clean the parts and keep them free from dust.

NOTE:

Inspect the bushings for burrs. If there is a burr, remove it with a knife, taking care not to peel off the teflon coating. If the bushings have a large crack or excessive play after installing them, replace them with the new ones.

- Apply front fork oil to the guide/slide bushing.
- Insert the inner tube into the outer tube.
- Install the seal with the special tool until the stopper ring groove of the outer tube can be seen.

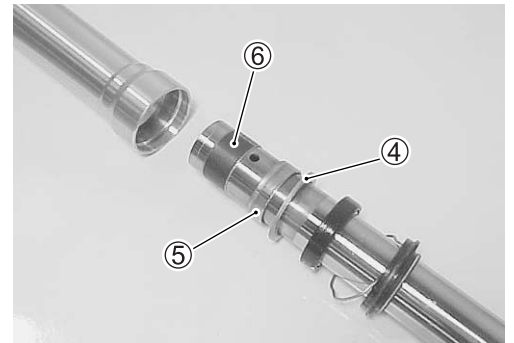

TOOL 09940-52861: Front fork oil seal installer set

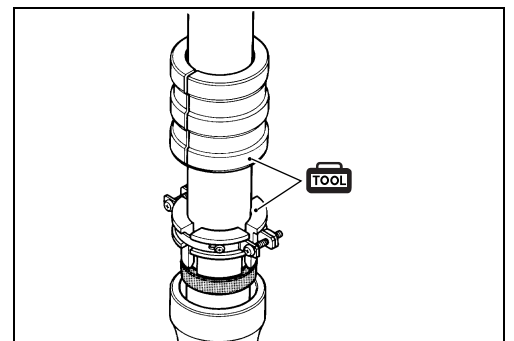

- Attach the stopper ring ⑦ securely to the stopper ring groove of the outer tube.
- Attach the dust seal ⑧.

NOTE:

After attaching the dust seal, make sure that there are no cracks around the circumference of the seal. Cracks could allow water, mud and the like to enter and cause an oil leak.

CAUTION

Use of grease as a substitute fork oil when installing the oil seal can result in an oil leak. Applying grease to the dust seal and oil seal can cause dirt to accumulate and damage the dust seal lip and oil seal lip.

Use only a thin coat of fork oil on the oil seal.

- Install the damper rod into the front fork.
- Apply THREAD LOCK SUPER “1322” to the front fork center bolt.

 **99000-32110: THREAD LOCK SUPER “1322”**

- Apply fork oil to the O-rings.

- Tighten the front fork center bolt to the special torque with the special tool.

 **Front fork center bolt: 55 N·m (5.5 kgf-m, 40.0 lb-ft)**

 **09940-30250: Front fork assembling tool**

- Install the spring guide ①, lock-nut ② onto the inner rod.

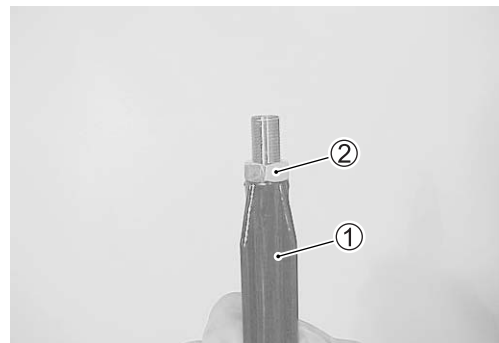
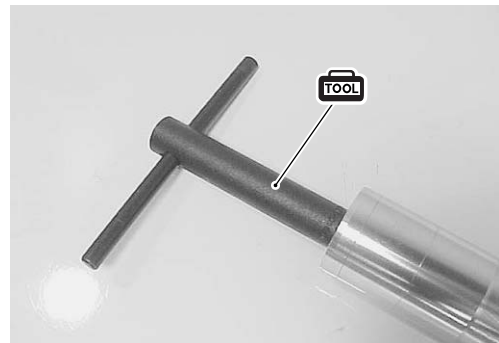
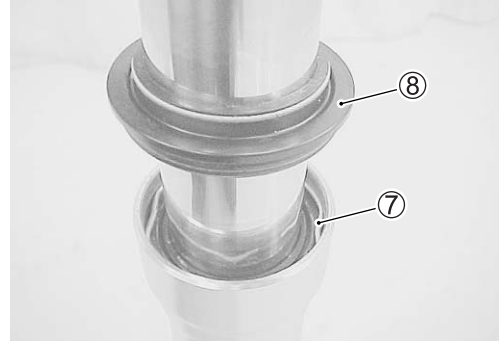

FORK OIL

- Place the front fork vertically without spring.
- Compress it fully.
- Pour specified front fork oil up to the top level of the outer tube.

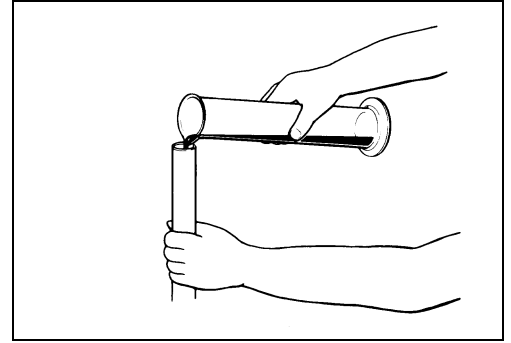

- Move the inner rod slowly with the special tool more than ten times until no more bubbles come out from the oil.

TOOL 09940-52841: Inner rod holder

NOTE:

Refill front fork oil up to the top of the outer tube to find bubbles while bleeding air.

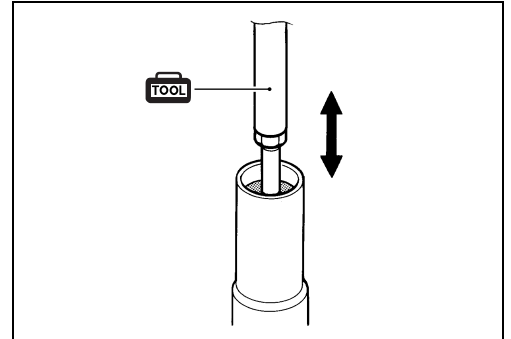

- Refill specified front fork oil up to the top level of the outer tube again. Move the outer tube up and down several strokes until no more bubbles come out from the oil.
- Keep the front fork vertically and wait 5 – 6 minutes.

NOTE:

* Always keep oil level over the cartridge top end, or air may enter the cartridge during this procedure.

* Take extreme attention to pump out air completely.

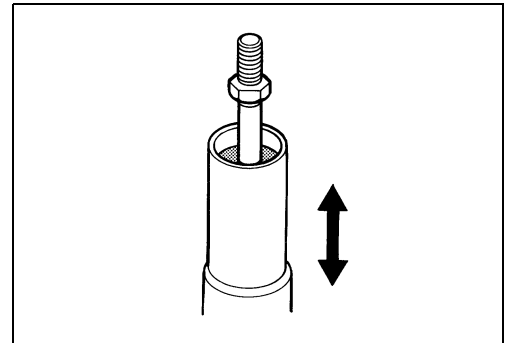

- Hold the front fork vertically and adjust fork oil level with the special tool.

NOTE:

When adjusting the fork oil level, compress the outer tube fully without the fork spring.

TOOL 09943-74111: Front fork oil level gauge

DATA Fork oil level (Standard): 124 mm (4.88 in)

FORK 99000-99001-SS5:SUZUKI FORK OIL SS-05

or an equivalent fork oil

DATA Standard fork oil capacity (each leg): 351 ml

(11.86/12.36 US/lmp oz)

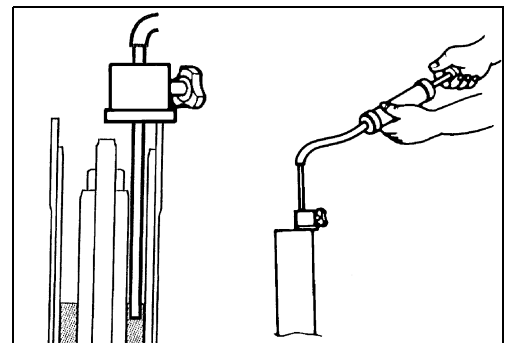

- Pull up the inner rod with the special tool.

 **09940-52841: Inner rod holder**

- Install the fork spring.

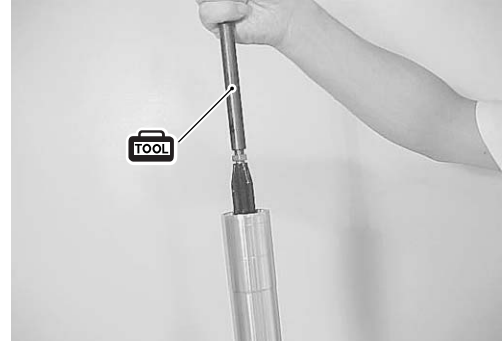

- Adjust the height H of the inner rod threads by turning the lock-nut ①.

H : 14 mm

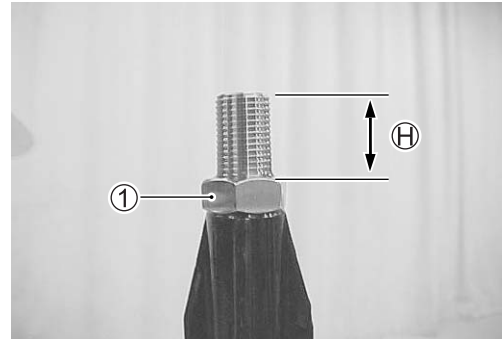

- Set the rebound damping adjuster 1.5 mm (0.06 in) as shown before assembling the front fork cap.

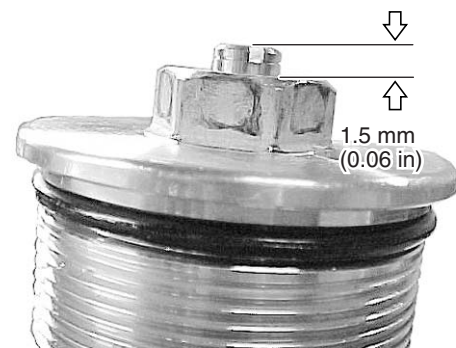

- Slowly turn the fork cap bolt ② to seat at the lock-nut ③ by hand tightening.

CAUTION

Be sure to adjust the rebound damping force adjuster to the softest position before installing the fork cap bolt.

- Hold the fork cap bolt and tighten the lock-nut to the specified torque.

 **Inner rod lock-nut: 20 N·m (2.0 kgf·m, 14.5 lb-ft)**

- Apply fork oil to the fork cap's O-ring.
- Temporarily tighten the fork cap bolt to the outer tube.

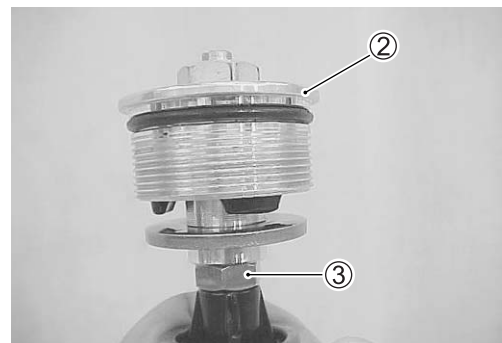

REINSTALLATION

- Reinstall the front forks.
- Set the aligning line ① on the outer tube to the upper surface of the steering stem head.
- Check that the air valve ② is positioned at the front.

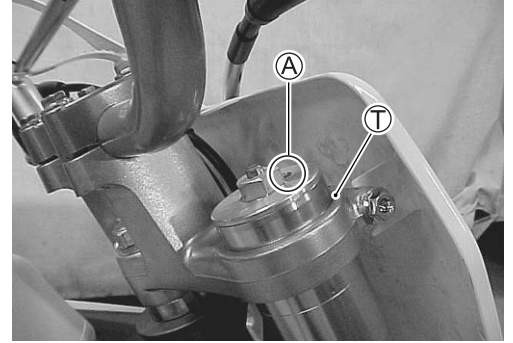

- Tighten the fork lower clamp bolts ① to the specified torque.

🔧 Fork lower clamp bolt: 23 N·m (2.3 kgf-m, 16.5 lb-ft)

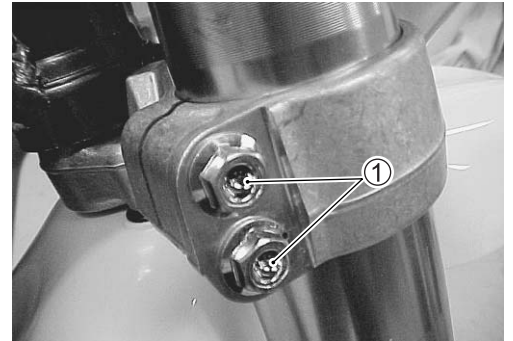

- Tighten the fork cap bolt ② to the specified torque.

🔧 Fork cap bolt: 35 N·m (3.5 kgf-m, 25.5 lb-ft)

- Tighten the fork upper clamp bolts ③ to the specified torque.

🔧 Fork upper clamp bolt: 23 N·m (2.3 kgf-m, 16.5 lb-ft)

- Install the front wheel. (👉 14-4)
- Install the brake caliper. (👉 15-8)
- Install the fork covers, brake hose guide and brake hose cover.

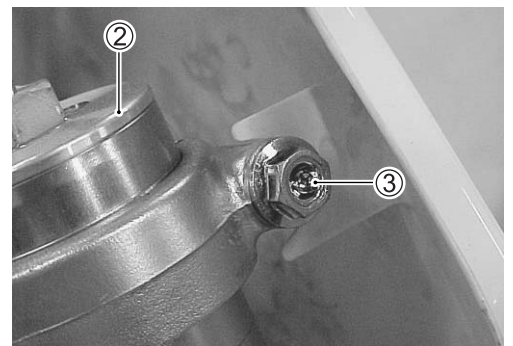

STEERING REMOVAL

- Remove the front wheel. (☞ 14-3)
- Remove the brake caliper. (☞ 15-6)
- Remove the front number plate.
- Remove the handlebar holder bolts ① and handlebars.
- Remove the brake hose guide.

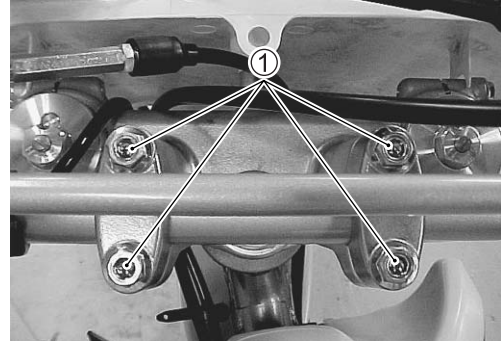

- Remove the front fender.



- Loosen the steering stem head nut and upper clamp bolts.
- Remove the steering stem head ①.

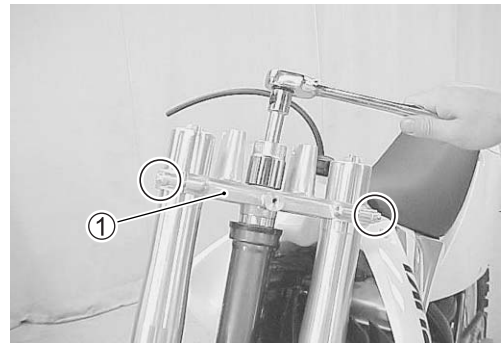

- Remove the front fork.

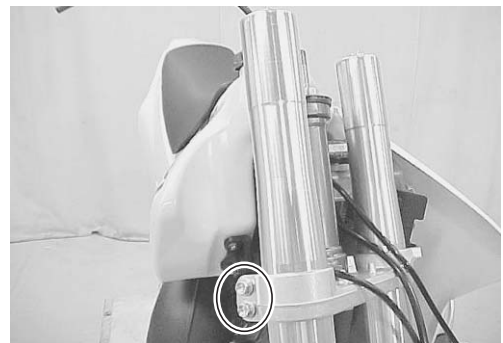

- Remove the steering nut with the special tools.

 **09940-14930: Steering nut socket wrench**

- Remove the steering stem ①.

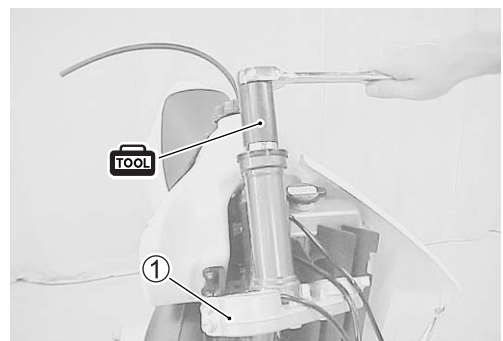

INSPECTION

- Inspect the bearing races for wear.
- Inspect the needle bearings for wear.
- Inspect the steering stem for distortion.

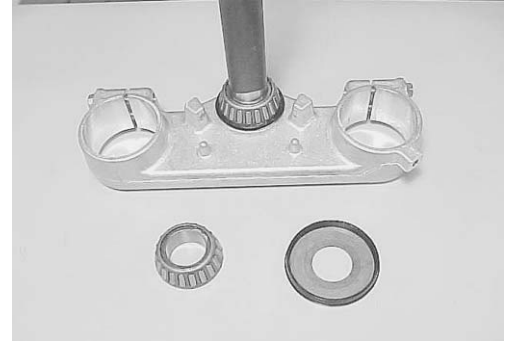

BEARING REPLACEMENT

NOTE:

Replace the outer race and bearing as a set.

- Remove the upper and lower outer races with the special tools.

TOOL 09941-54911: Steering race remover
 09941-74911: Steering bearing installer

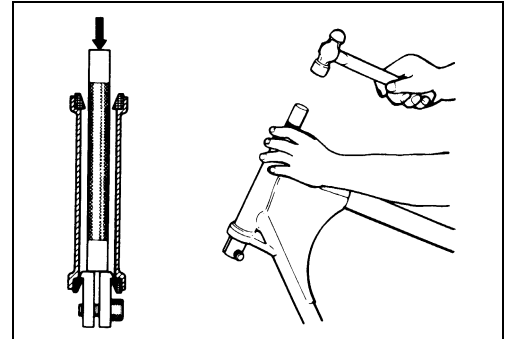

- Remove the lower bearing.

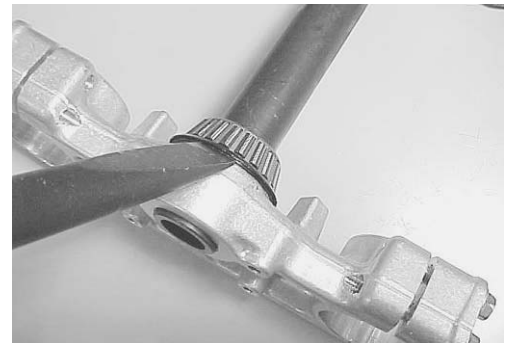

- Install the lower bearing to the steering stem using a suitable size spacer.

CAUTION

- * Press-fit the bearing by pressing the inner race (A).
- * Do not press the cage (B) of the bearing.

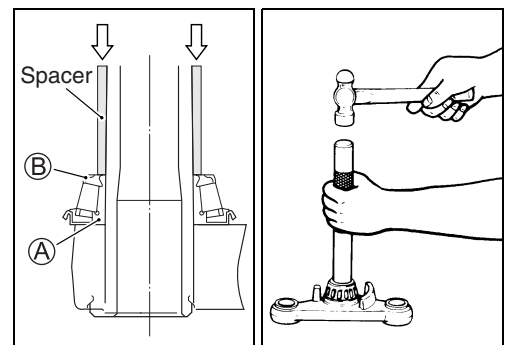

- Install the upper and lower outer races with the special tools.

TOOL 09941-34513: Steering outer race and swingarm bearing installer

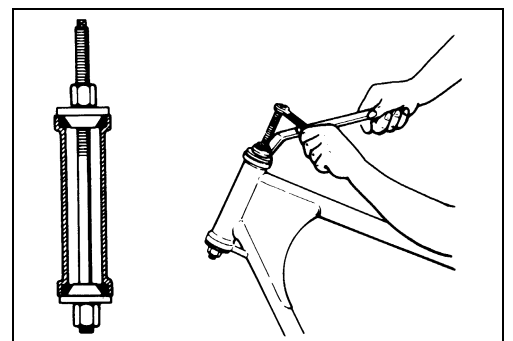

REASSEMBLY

- Apply grease to the bearings and dust seals.
- Install the steering stem, upper bearing and steering stem nut.
- Tighten the steering stem nut with the special tool.

 **09940-14930: Steering nut socket wrench**

 **Steering stem nut: 45 N·m (4.5 kgf-m, 32.5 lb-ft)**

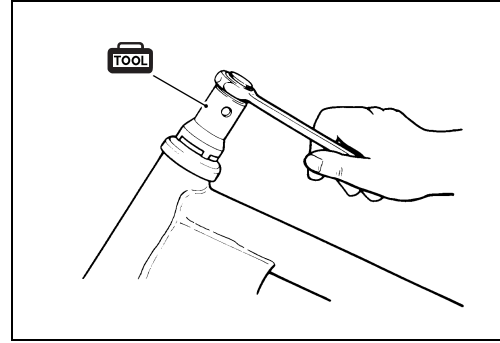

- Move the steering stem right and left several times to seat the bearings.
- Turn back the steering stem nut by 1/4 to 1/2 turn.
- Install the front forks temporarily to the steering stem.
- Install the steering stem head and tighten the steering stem nut temporarily.
- Tighten the steering stem head nut to the specified torque.

 **Steering stem head nut: 65 N·m (6.5 kgf-m, 47.0 lb-ft)**

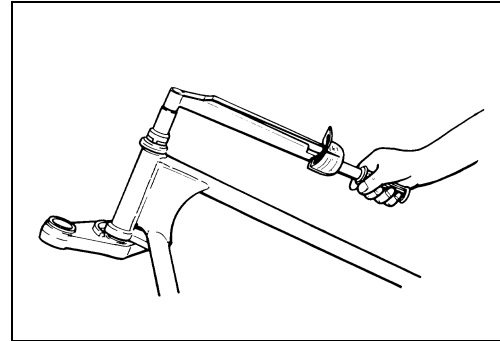

- Reassemble the front wheel and the brake caliper. (14-3 and 15-8)
- Reassemble the handlebars. Align the punched mark on the handlebars with the mating surface of front side of the left handlebar holder.



- Set the punched mark (FWD mark) on the handlebar holders as shown in the illustration.
- Tighten the handlebar holder bolts to the specified torque.

NOTE:

First tighten the handlebar holder bolts (A).

 **Handlebar holder bolt: 26 N·m (2.6 kgf-m, 19.0 lb-ft)**

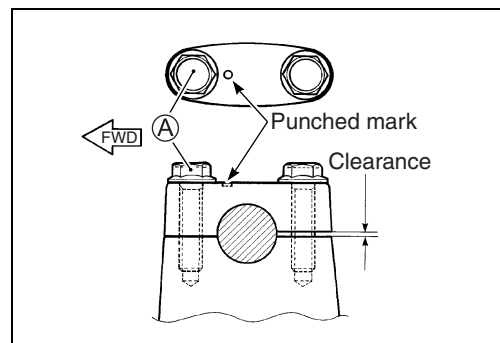

- Reinstall the brake hose guide.
- Rock the front fork forward and backward to ensure that the steering has no play.
- Inspect the steering for smooth movement so that the handlebars can move right and left under its own weight.
- Reinstall the front number plate and the front fender.

NOTE:

When installing the front number plate, fit the holes (A) to the steering stem's projections (B).

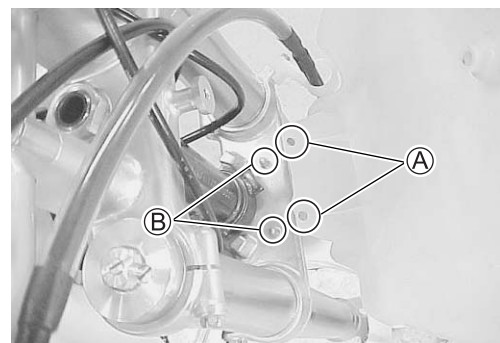

REAR SUSPENSION

CONTENTS

CONSTRUCTION	17-2
REAR SUSPENSION	17-2
REAR SHOCK ABSORBER	17-3
REAR SHOCK ABSORBER REMOVAL	17-3
SPRING REMOVAL	17-4
REAR SHOCK ABSORBER INSPECTION	17-4
SPRING INSTALLATION	17-5
REAR SHOCK ABSORBER INSTALLATION	17-5
OIL REPLACEMENT PROCEDURE	17-6
REAR SHOCK ABSORBER DISASSEMBLY AND INSPECTION	17-9
REAR SHOCK ABSORBER REASSEMBLY	17-10
REAR SHOCK ABSORBER DISPOSAL	17-10
SWINGARM	17-11
SWINGARM REMOVAL	17-11
SWINGARM INSPECTION	17-12
BEARING REPLACEMENT	17-12
SWINGARM REASSEMBLY	17-13
REAR SUSPENSION LINKAGE	17-13
REAR SUSPENSION LINKAGE REMOVAL	17-13
REAR SUSPENSION LINKAGE INSPECTION	17-14
CUSHION LEVER AND CUSHION ROD BEARING REPLACEMENT ..	17-14
REAR SUSPENSION LINKAGE REASSEMBLY	17-16

CONSTRUCTION REAR SUSPENSION

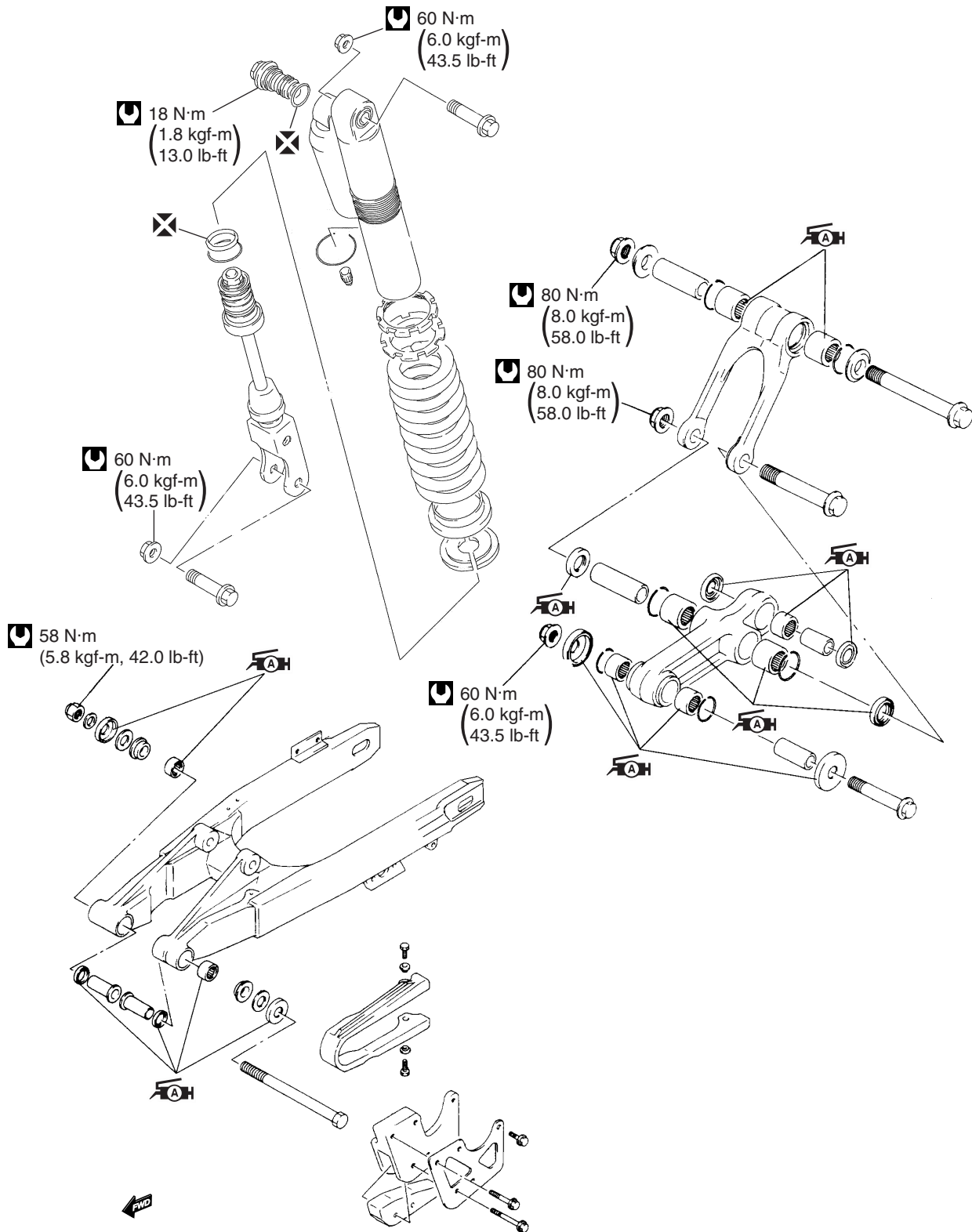

REAR SHOCK ABSORBER REAR SHOCK ABSORBER REMOVAL

- Place a block under chassis tubes.
 - Remove the frame covers and seat. (☞ 5-2)
 - Loosen the air cleaner clamp screw (A).
-
- Remove the frame side tube (1).
-
- Loosen the bolts and screw (2).
 - Remove the air cleaner box.
-
- Loosen the rear shock absorber upper mounting bolt and nut (3).
-
- Loosen the rear shock absorber lower mounting bolt and nut (4).
 - Remove the rear shock absorber.

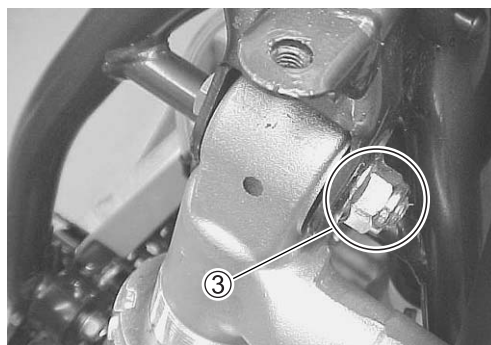
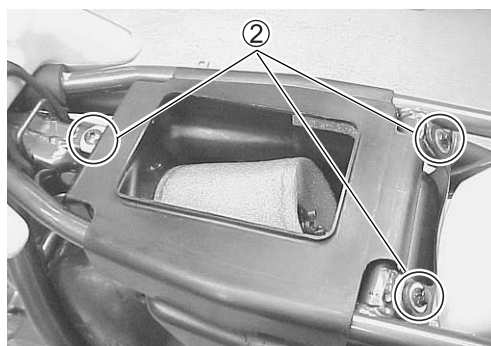
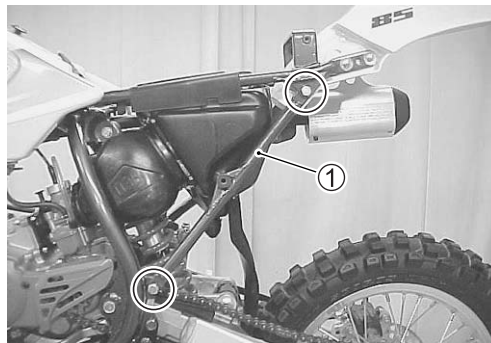

SPRING REMOVAL

- Remove the rear shock absorber unit from the frame.
(☞ 17-3)
- Loosen the lock-nut ① and turn the adjuster ② with the special tool.
- Turn the lock-nut ① and adjuster ② fully to the end of the thread.

TOOL 09910-60611: Universal clamp wrench

- Remove the spring seat ③, spring retainers ④ and the spring ⑤ from the rear shock absorber.

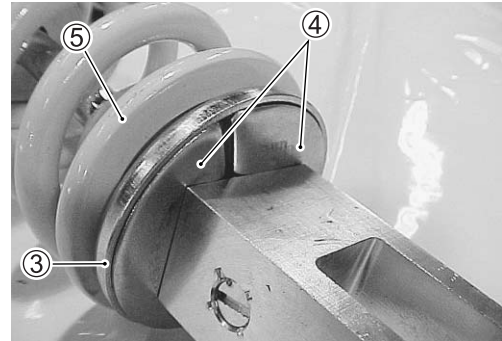
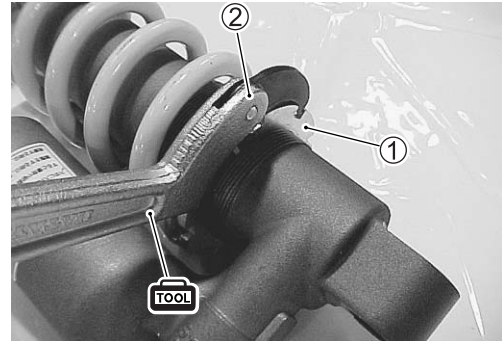

REAR SHOCK ABSORBER INSPECTION

- Inspect the rear shock absorber for oil leakage.
- Inspect the damper rod for scratch, damage and smooth movement.
- Inspect the bump rubber for deterioration and damage.
- Inspect the damper rod hidden by the bump rubber by moving the bump rubber.

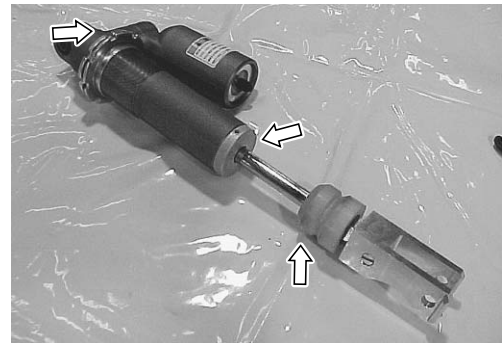

- Inspect the upper bushing for damage.

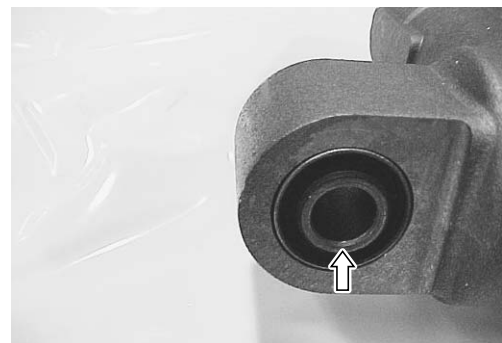

SPRING INSTALLATION

- Install the lock-nut, adjuster, spring, spring seat and spring retainers.

NOTE:

Install the spring as small diameter side is seated to the adjuster.

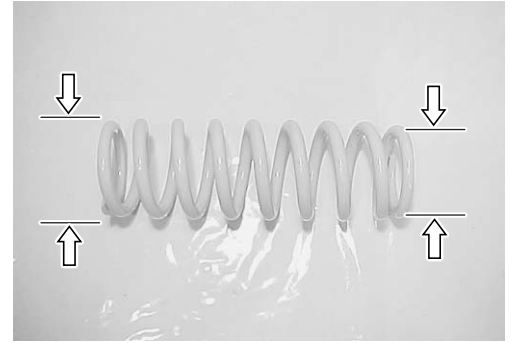

- Adjust the spring set length and tighten the lock-nut.

- DATA** Standard spring set length:
- 3.1 mm (0.12 in) compressed from spring free length (RM85)
 - 4.8 mm (0.18 in) compressed from spring free length (RM85L)

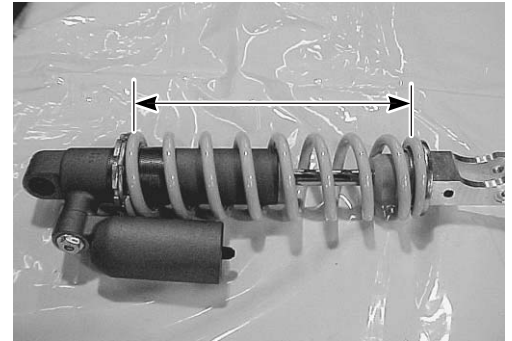

- DATA** Spring set length adjustable range:
- 2 – 12 mm (0.08 – 0.47 in) compressed from spring free length

- 🔧 Rear shock absorber lock-nut:
45 N·m (4.5 kgf-m, 29.0 lb-ft)

REAR SHOCK ABSORBER INSTALLATION

- Remount the rear shock absorber to the frame and the cushion lever.
- Tighten the upper and lower mounting bolts and nuts to the specified torque.

- 🔧 Rear shock absorber mounting nuts:
60 N·m (6.0 kgf-m, 43.5 lb-ft)

- Install the air cleaner.

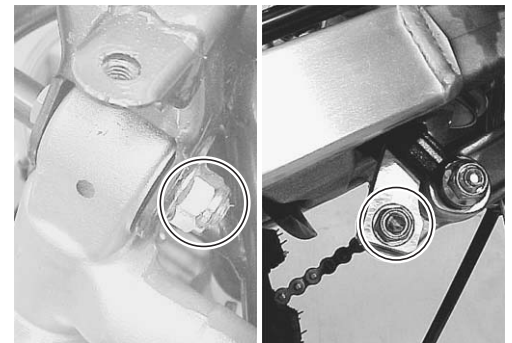

OIL REPLACEMENT PROCEDURE

TOOLS AND EQUIPMENT

- Following tools and equipment are required to perform oil replacement.

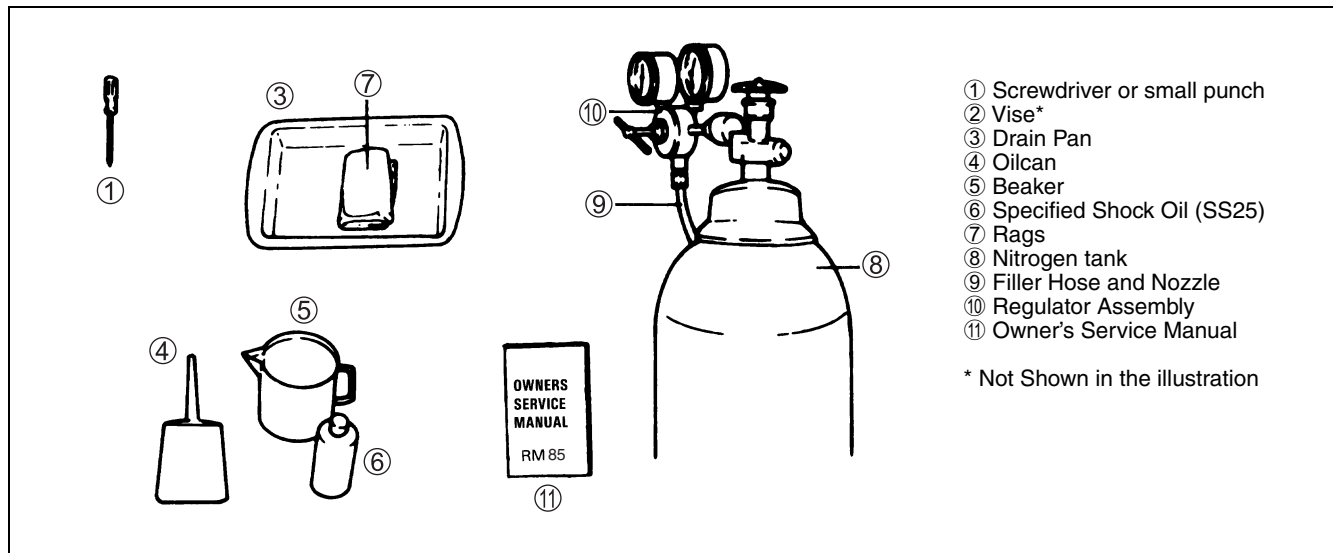

OIL REPLACEMENT PROCEDURE

- Remove the rear shock absorber unit from the frame. Clean and dry it. (☞ 17-3)
- Remove the spring from the rear shock absorber unit. (☞ 17-4)

NOTE:

Inspect the rear shock absorber unit for oil leak.

Turn the rebound damping force adjuster screw counterclockwise until it stops, so that the rear suspension oil can be poured easily.

- Remove the valve cap. Press the valve with a screwdriver to bleed out nitrogen gas.



⚠ WARNING

Releasing high pressure gas from the rear shock absorber unit can be hazardous.

Never perform any servicing until the nitrogen gas pressure has been released from the rear shock absorber unit. When releasing the gas pressure, place a rag over the gas valve and use the tip of a screwdriver etc. to press the valve. Do not use your finger to depress the gas valve, and direct the valve away from your face and body.

- Remove the compression adjuster assembly ① with the special tool from the rear shock absorber.

TOOL 09941-53650: Rear shock absorber socket wrench

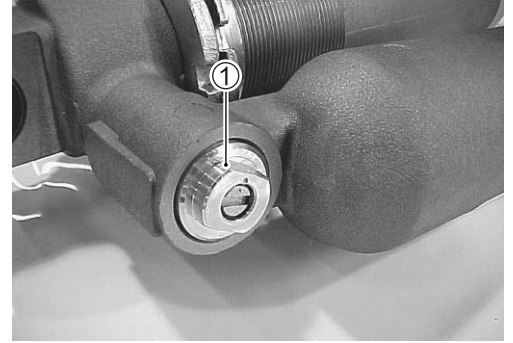

- Place a drain pan under the rear shock absorber unit.
- Move the rod and drain the oil completely.
- Push the valve core again to equalize the bladder to atmospheric pressure.



- Pour the fresh specified rear suspension oil as shown while moving the rod.

NOTE:

Be sure to extend the rod after filling the oil.

- Tilt the shock absorber unit as shown and pour the fresh rear suspension oil fully into the reservoir tank.

RS 99000-99001-S25: SUZUKI REAR SUSPENSION OIL SS-25

DATA Oil capacity: Approx. 195 ml (6.6/6.9 US/Imp oz)

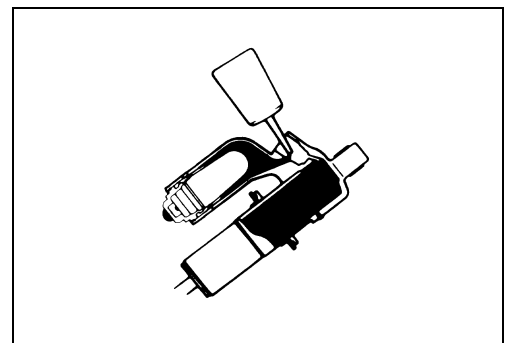
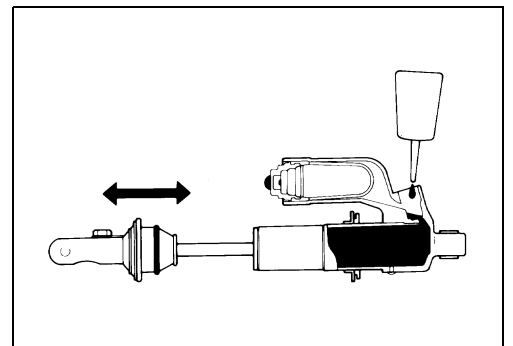

- Cover the compression adjuster hole by the root of your thumb.
- Tilt and shake the rear shock absorber unit to fill the reservoir tank with the oil.
- Add the oil and repeat the above procedure until the reservoir tank is filled with the oil completely.



- Reinstall the compression adjuster assembly ① with the special tool.

NOTE:

Replace the O-rings on the compression adjuster assembly with new ones.

 **Compression adjuster assembly:**

18 N·m (1.8 kgf-m, 13.0 lb-ft)

 **09941-53650: Rear shock absorber socket wrench**

- Fill the rear shock absorber unit with nitrogen gas to 1 000 kPa (10 kgf/cm², 142 psi).
- Tighten the gas valve cap.
- Reinstall the spring and mount the shock absorber. (☞ 17-5)

 **WARNING**

Use of flammable gas for pressuring the rear shock absorber unit can be hazardous. Flammable gas such as gas welding oxygen can create a fire hazard.

Use nitrogen gas. If is nitrogen gas is not available, compressed air free from water can be substituted.

 **WARNING**

Applying too much pressure to the rear shock absorber unit may rupture the rear shock absorber unit.

Be sure to fill the rear shock absorber unit to the specified pressure.

CAUTION

Riding the motorcycle with abnormal gas pressure can damage the rear shock absorber unit. Low gas pressure can result in oil leakage. Abnormal gas pressure cannot provide normal rear shock absorber unit performance.

Be sure to fill the rear shock absorber unit to the specified pressure.



REAR SHOCK ABSORBER DISASSEMBLY AND INSPECTION

- Remove the rear shock absorber unit from the frame. Clean and dry it. (☞ 17-3)
- Remove the spring from the rear shock absorber. (☞ 17-4)
- Turn the rebound damping force adjuster to the softest position.
- Press the valve with a screwdriver to bleed out nitrogen gas. (☞ 17-6)
- Remove the compression adjuster assembly. Drain the oil. (☞ 17-7)
- Vise the rear shock absorber unit in inverted position.
- Evenly hammer the stopper ① with the screwdriver or equivalent and remove it from the rear shock absorber body.

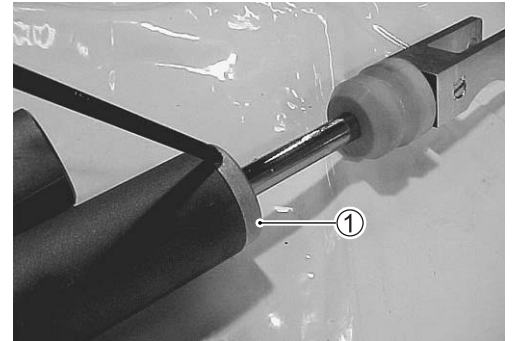

- Depress the seal case ② with the screwdriver until the circlip ③ is fully exposed.
- Remove the circlip ③.

NOTE:

Avoid scratching the inner surface of the shock absorber body to avoid oil leaks.

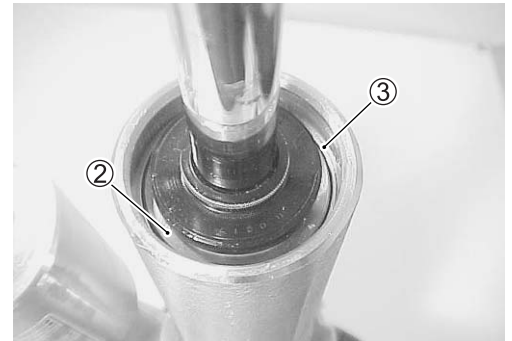

- Extract the damper rod assembly from the shock absorber body.
- Inspect the oil seal and O-rings.
- Inspect the damper rod for bends and scratches.
- Inspect the inner surface of the body.
- Inspect the “teflon coating metal” on the piston.
- Replace O-rings with new ones.
- Replace the “teflon coating metal” by cutting off the old one and sliding the new one onto the piston if necessary.

REAR SHOCK ABSORBER REASSEMBLY

- Apply the rear suspension oil to the O-rings and the “teflon coating metal”.
- Insert the damper rod assembly ① and install the new circlip ②.
- Pull up the damper rod assembly ① until it is stopped by the circlip ②.
- Install the stopper to the shock absorber body.
- Fill the specified rear suspension oil in the rear shock absorber. (☞ 17-7)

RS 99000-99001-S25: SUZUKI REAR SUSPENSION OIL SS-25

DATA Oil capacity: Approx. 195 ml (6.6/6.9 US/Imp oz)

- Reinstall the compression adjuster assembly. (☞ 17-8)
- Pressure the rear shock absorber unit with nitrogen gas to 1 000 kPa (10 kgf/cm², 142 psi). (☞ 17-8)
- Reassemble the spring and adjust the spring set length. (☞ 17-5)
- Tighten the valve cap.
- Remount the rear shock absorber to the frame. (☞ 17-5)

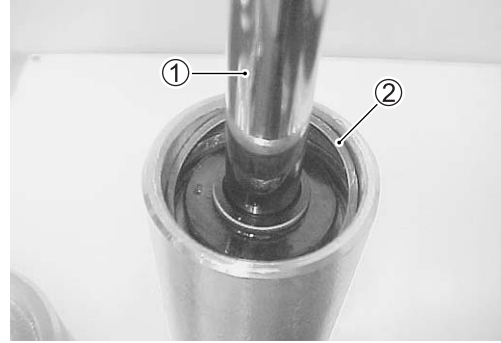

REAR SHOCK ABSORBER DISPOSAL

High pressure nitrogen gas is sealed in the rear shock absorber unit. Be sure to release gas before disposing the rear shock absorber unit.

- Remove the valve cap.
- Press the valve with a screwdriver.



⚠ WARNING

Releasing high pressure gas from the rear shock absorber unit can be hazardous.

Place a rag over the valve and push the valve with a screwdriver to release nitrogen gas. Do not use your finger to push the valve, and direct the valve away from your face and body.



SWINGARM

SWINGARM REMOVAL

- Remove the rear wheel. (☞ 14-5)

- Remove the chain guide ①.

- Remove the rear brake hose guide ②.
- Remove the rear brake caliper ③.
- Remove the drive chain.

- Remove the rear cushion rod bolt and nut ④.
- Remove the swingarm pivot nut ⑤.
- Remove the swingarm by removing the pivot shaft.

- Remove the following parts from the swingarm.
 - Spacer ⑥
 - Dust seal ⑦
 - Washer ⑧

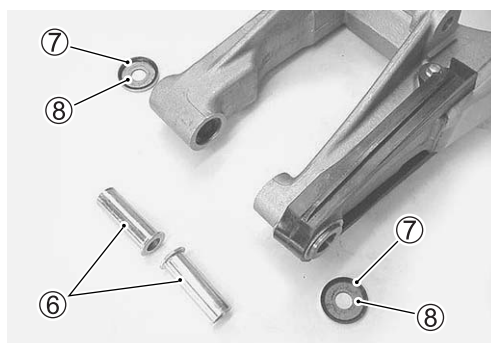
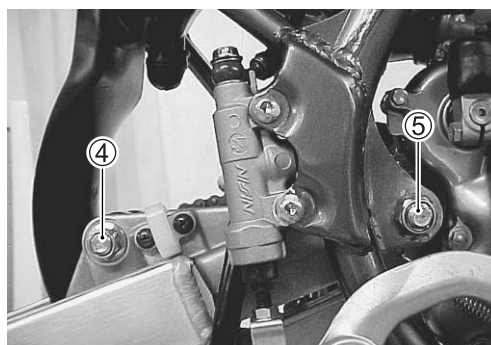
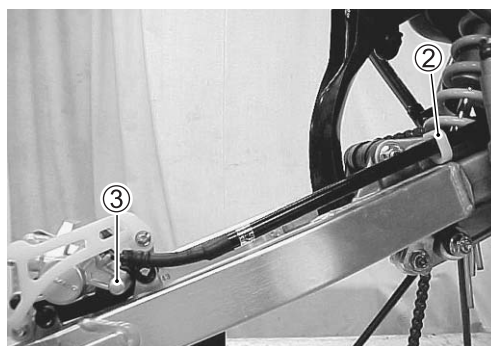
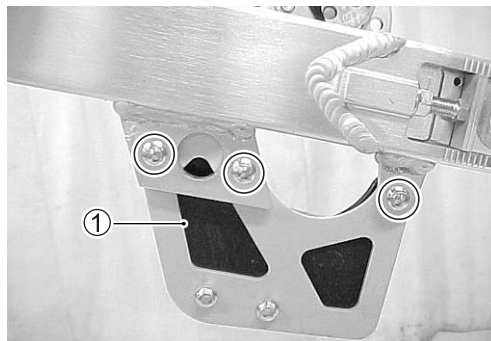

SWINGARM INSPECTION

- Measure the pivot shaft runout with a dial gauge and V-blocks.

DATA Swingarm pivot shaft runout
Service Limit: 0.3 mm (0.01 in)

- Inspect the swingarm for cracks and damage.
- Inspect the bearings, spacers and oil seals for damage.
- Insert the spacers into the bearings and inspect them for play and smooth movement.

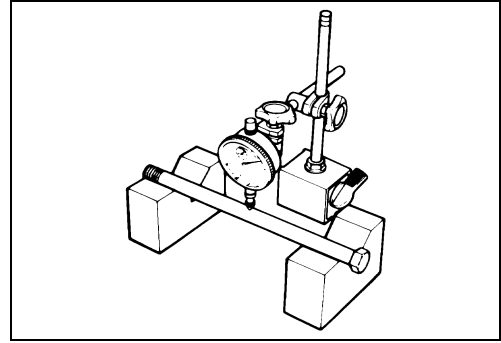

BEARING REPLACEMENT

- Remove the bearing and collar with the special tool.

TOOL 09930-30102: Sliding hummer
 09923-73210: Bearing puller

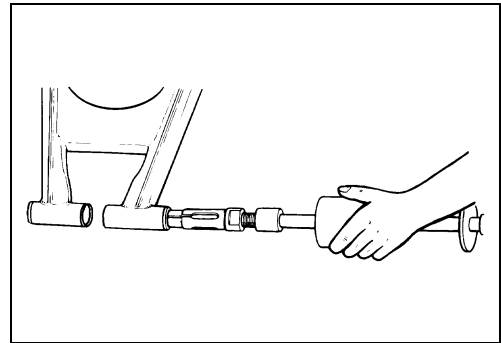

- Press-fit the bearing ① and collar ② into the swingarm ③ with the special tool and a suitable tool.

TOOL 09924-84521: Bearing installer set

- Apply grease to the bearings, lips of dust seal and spacers.

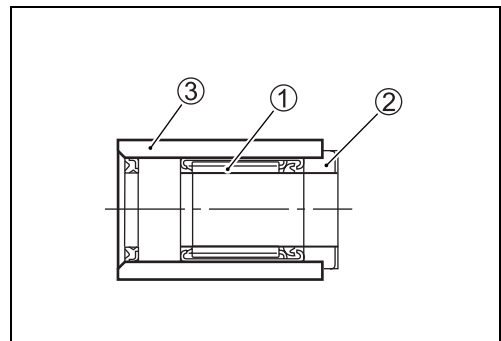
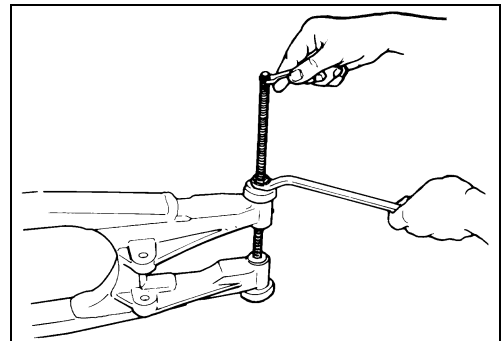





SWINGARM REASSEMBLY

- Reassemble the following parts into the swingarm.
 - ① Spacer
 - ② Dust seal
 - ③ Washer
- Apply grease to the dust seals, bearings and spacers.
- Install the swingarm to the frame.
- Tighten the swingarm pivot nut ④ to the specified torque.

 **Swingarm pivot nut: 58 N·m (5.8 kgf-m, 42.0 lb-ft)**

- Tighten the rear cushion rod ⑤ nut to the specified torque.

 **Rear cushion rod nut: 80 N·m (8.0 kgf-m, 58.0 lb-ft)**

- Reassemble the chain guide.
- Reassemble the rear brake caliper. ( 15-8)
- Reassemble the rear wheel. ( 14-6)
- Adjust the drive chain slack. ( 2-13)

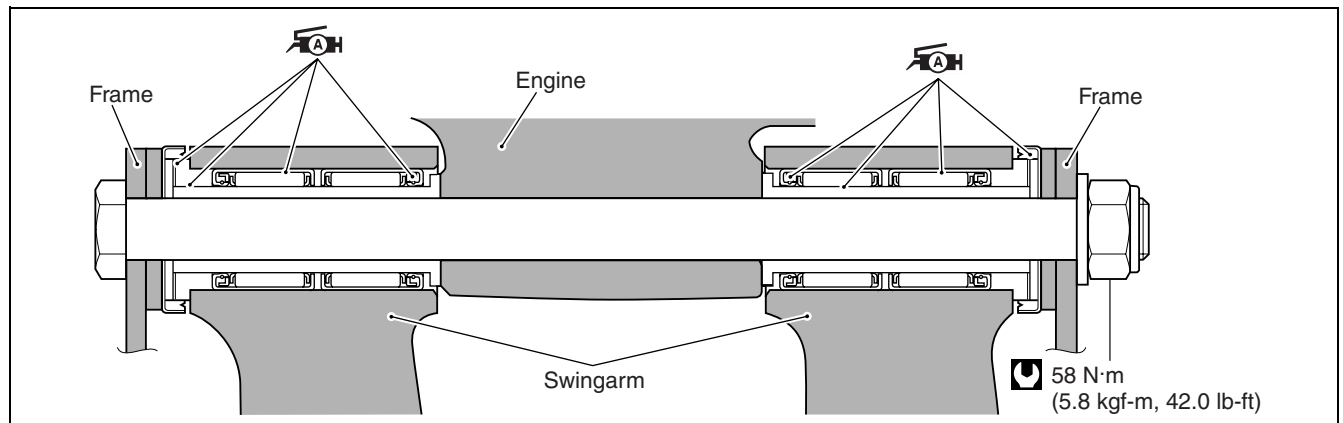
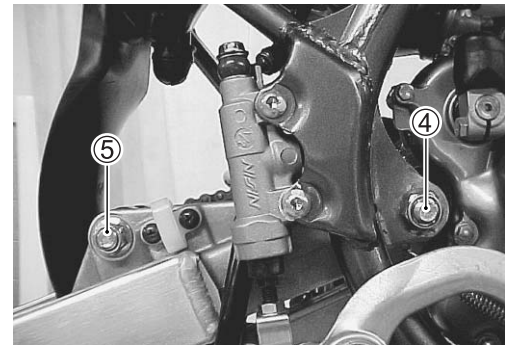
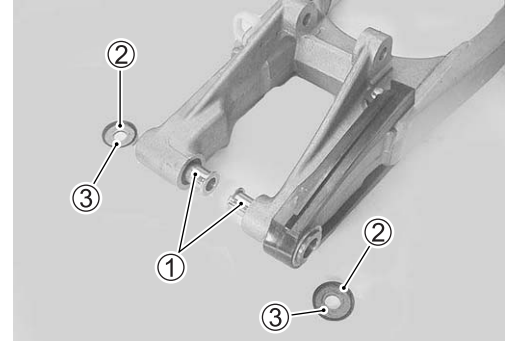

REAR SUSPENSION LINKAGE REAR SUSPENSION LINKAGE REMOVAL

- Loosen the cushion lever bolt/nut.
- Loosen the cushion rod upper bolt/nut.
- Loosen the shock absorber lower bolt and nut.
- Remove the cushion lever assy.



- Remove the cushion rod ① from the cushion lever ②.

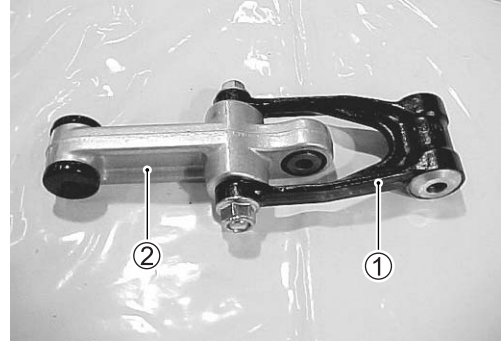

REAR SUSPENSION LINKAGE INSPECTION

- Inspect the cushion lever and cushion rod for damage.
- Inspect the dust seals and spacers for damage.
- Inspect the bearings for damage.
- Insert the spacers into the bearings and inspect them for smooth movement.

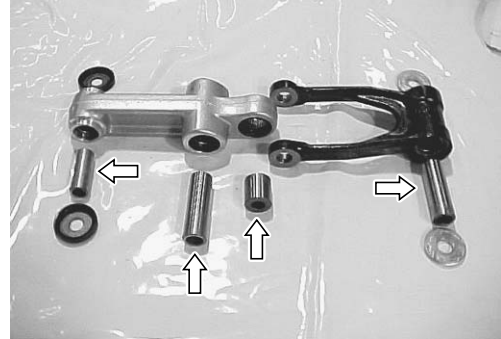

CUSHION LEVER AND CUSHION ROD BEARING REPLACEMENT

- Remove the spacers and dust seals.
- Remove the circlips.
- Remove the bearings with the special tool.

 09921-20220: Bearing remover set

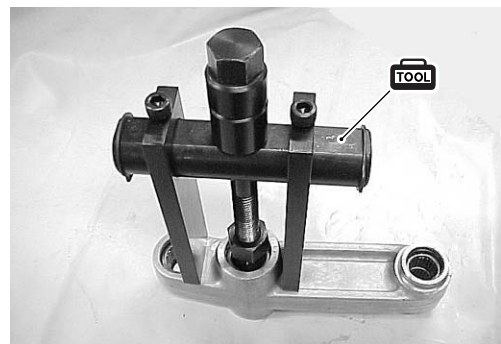
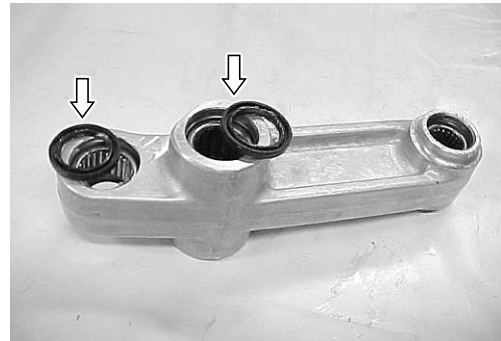

- Apply grease to the bearings.
- Install the bearings with the special tool and pipes, 24 mm (0.9 in) in diameter and 4 mm (0.2 in) in length.

TOOL 09941-34513: Bearing installer set

NOTE:

Position the bearings by referring to the illustration of page 17-16.

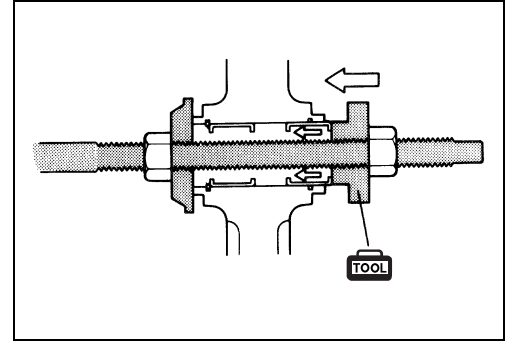

- Install the circlips.
- Install the dust seals.
- Apply grease to the spacers and dust seals.

NOTE:

Position the dust seal so that the "outside" letter faces outside.

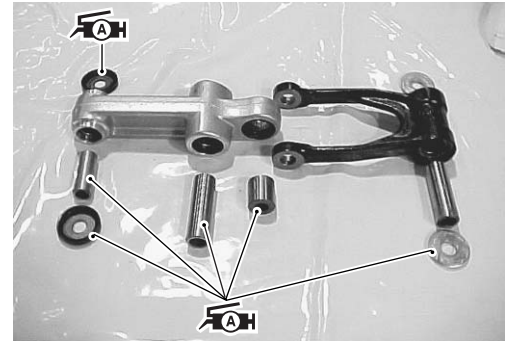

REAR SUSPENSION LINKAGE REASSEMBLY

- Reassemble the rear suspension linkage.
- Tighten the nuts to the specified torque.

Tightening torque:

- Ⓐ: 60 N·m (6.0 kgf-m, 43.5 lb-ft)
- Ⓑ: 60 N·m (6.0 kgf-m, 43.5 lb-ft)
- Ⓒ: 80 N·m (8.0 kgf-m, 58.0 lb-ft)
- Ⓓ: 60 N·m (6.0 kgf-m, 43.5 lb-ft)
- Ⓔ: 80 N·m (8.0 kgf-m, 58.0 lb-ft)

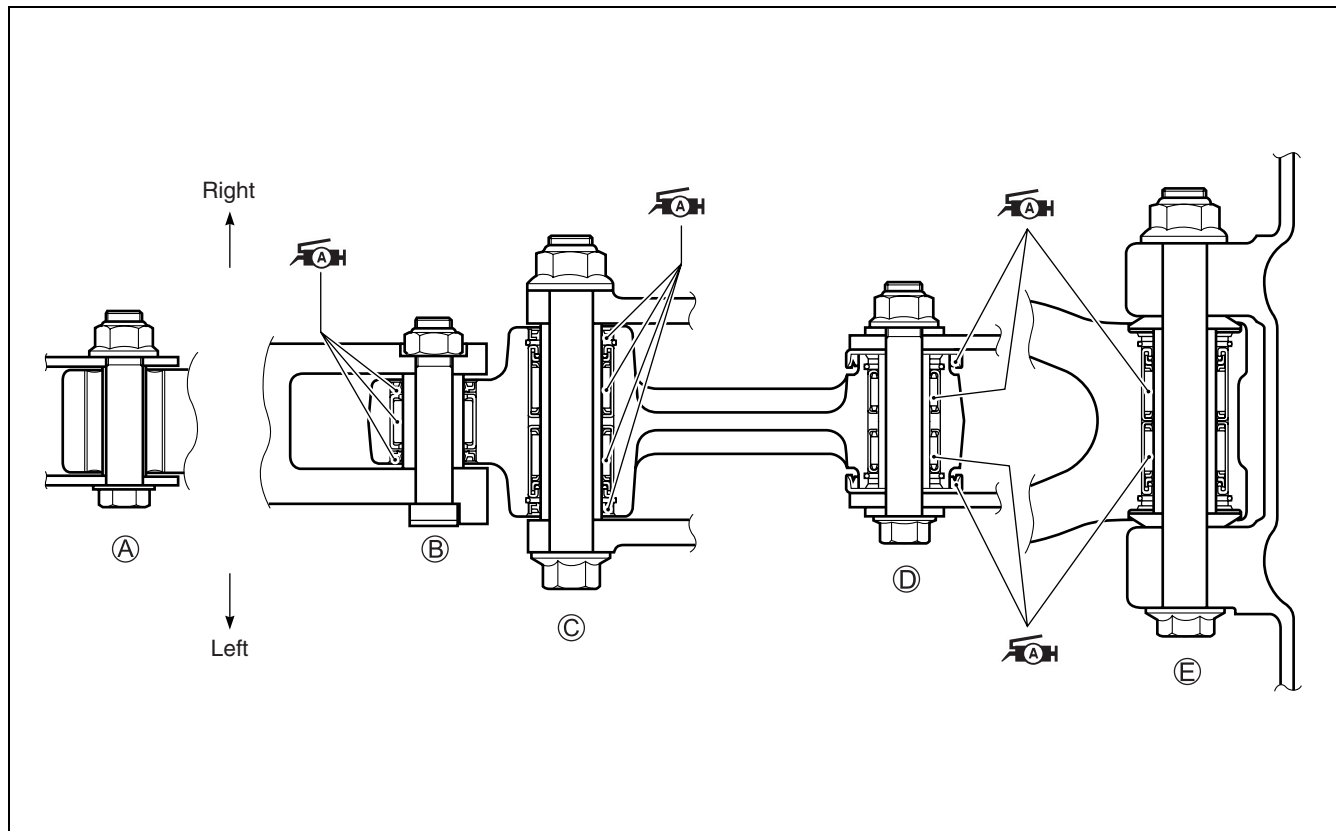
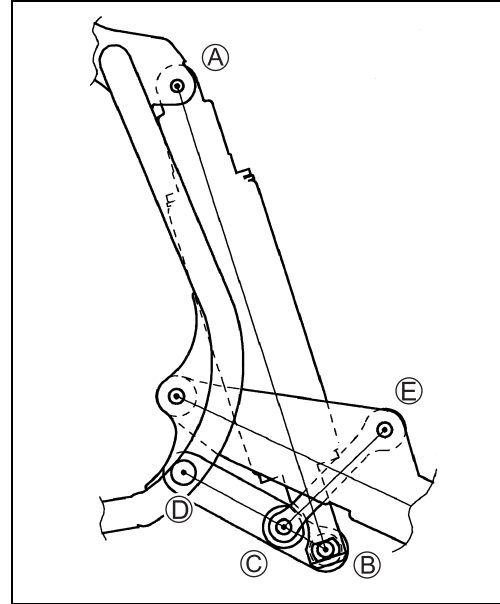

CAUTION

- * Improperly reassembled rear suspension linkage bolts can interfere with suspension movement and damage the rear suspension linkage.
- * Make sure that the rear shock absorber rebound damping adjuster on the bottom bracket of the rear shock absorber is located to the right side.
- * Insert the rear suspension linkage bolts from the left side.

SERVICING INFORMATION

CONTENTS

<i>SERVICE DATA</i>	<i>18- 2</i>
<i>SPECIAL TOOLS</i>	<i>18- 7</i>
<i>WIRE, CABLE AND HOSE ROUTING</i>	<i>18- 9</i>
<i>SPECIFICATIONS</i>	<i>18-17</i>
<i>SETTING DATA</i>	<i>18-19</i>

SERVICE DATA

CYLINDER + PISTON + PISTON RING

Unit: mm (in)

ITEM	STANDARD		LIMIT
Piston to cylinder clearance	0.040 – 0.050 (0.0016 – 0.0020)		0.120 (0.0047)
Cylinder bore	48.000 – 48.015 (1.8898 – 1.8904) Measure 15 (0.59) from the top surface.		Nicks or scratches
Piston diam.	47.955 – 47.970 (1.8880 – 1.8886) Measure 16 (0.63) from the skirt end.		47.880 (1.8850)
Cylinder distortion	—		0.05 (0.002)
Cylinder head distortion	—		0.05 (0.002)
Piston ring free end gap	N	Approx. 4.0 (0.16)	3.2 (0.13)
Piston ring to groove clearance	0.020 – 0.060 (0.0008 – 0.0024)		—
Piston ring end gap	0.20 – 0.40 (0.008 – 0.0016)		0.80 (0.031)
Piston pin bore	14.002 – 14.008 (0.5513 – 0.5515)		14.030 (0.5524)
Piston pin O.D.	13.995 – 14.000 (0.5510 – 0.5512)		13.980 (0.5504)
Reed valve clearance	—		0.2 (0.008)

CONROD + CRANKSHAFT

Unit: mm (in)

ITEM	STANDARD		LIMIT
Conrod small end I.D.	18.003 – 18.011 (0.7088 – 0.7091)		18.040 (0.7102)
Crank web to web width	44.9 – 45.1 (1.767 – 1.775)		—
Crankshaft runout	—		0.05 (0.002)

CLUTCH

Unit: mm (in)

ITEM	STANDARD		LIMIT
Clutch lever play	10 – 15 (0.4 – 0.6)		—
Drive plate thickness	2.7 – 2.9 (0.106 – 0.114)		2.4 (0.094)
Driven plate distortion	—		0.10 (0.004)
Clutch spring free length	41.5		39.4 (1.55)

RADIATOR

ITEM	STANDARD		LIMIT
Radiator cap valve opening pressure	110 kPa (1.1 kgf/cm ² , 16 psi)		—

TRANSMISSION

Unit: mm (in) Except ratio

ITEM		STANDARD		LIMIT
Primary reduction ratio		3.444 (62/18)		—
Final reduction ratio		3.357 (47/14)	RM85	—
		3.615 (47/13)	RM85L	—
Gear ratios	Low	2.545 (28/11)		—
	2nd	1.933 (29/15)		—
	3rd	1.571 (22/14)		—
	4th	1.333 (20/15)		—
	5th	1.166 (21/18)		—
	Top	1.045 (23/22)		—
Shift fork to groove clearance		No.1, No.2 & No.3	0.05 – 0.25 (0.002 – 0.010)	0.45 (0.018)
Shift fork groove width		No.1	3.95 – 4.05 (0.156 – 0.159)	—
		No.2 & No.3	4.45 – 4.55 (0.175 – 0.179)	—
Shift fork thickness		No.1	3.80 – 3.90 (0.150 – 0.154)	—
		No.2 & No.3	4.30 – 4.40 (0.169 – 0.173)	—

DRIVE CHAIN

Unit: mm (in)

ITEM		STANDARD		LIMIT
Drive chain	Type	D.I.D 428DS		—
	Links	118	RM85	—
		122	RM85L	—
	20-pitch length	—		259 (10.2)
Drive chain slack		40 – 50 (1.6 – 2.0)		—

CARBURETOR

ITEM		SPECIFICATION
Carburetor type		KEIHIN PE28
Bore size		28 mm
I.D. No.		03B3
Float height		19.0 ± 0.5 mm (0.75 ± 0.02 in)
Main jet	(M.J.)	#128
Jet needle	(J.N.)	24NAAH-3rd
Slow jet	(S.J.)	#50
Air screw	(P.A.S.)	2 turns out
Throttle cable play		2 – 4 mm (0.08 – 0.16 in) at the throttle grip

ELECTRICAL

Unit: mm (in)

ITEM	SPECIFICATION		NOTE
Spark plug	Type	NGK: BR10ES	
	Gap	0.7 – 0.8 (0.028 – 0.031)	
Spark performance	Over 8 (0.3) at 1 atm.		
Ignition coil resistance	Primary	0.2 – 1.0 Ω	W/BI – Ground
	Secondary	12 – 20 kΩ	Plug cap – Ground
Magneto coil resistance	100 – 160 Ω		B/R – R/W
	140 – 230 Ω		R/W – B/W
	240 – 380 Ω		B/R – B/W
Ignition coil primary peak voltage	200 V and more		⊕: Ground ⊖: W/BI

BRAKE + WHEEL

Unit: mm (in)

ITEM	STANDARD		LIMIT	
Brake lever play	5 – 20 (0.20 – 0.79)		—	
Brake disc thickness	Front	2.8 ± 3.2 (0.110 ± 0.126)	2.5 (0.10)	
	Rear	2.85 ± 3.15 (0.112 ± 0.124)	2.5 (0.10)	
Brake disc runout	—		0.30 (0.012)	
Master cylinder bore	Front	11.000 – 11.043 (0.4331 – 0.4348)	—	
	Rear	12.700 – 12.743 (0.5000 – 0.5017)	—	
Master cylinder piston diam.	Front	10.957 – 10.984 (0.4314 – 0.4324)	—	
	Rear	12.657 – 12.684 (0.4983 – 0.4994)	—	
Brake caliper cylinder bore	Front	30.230 – 30.306 (1.1902 – 1.1931)	—	
	Rear	27.000 – 27.076 (1.0630 – 1.0660)	—	
Brake caliper piston diam.	Front	30.150 – 30.200 (1.1870 – 1.1890)	—	
	Rear	26.920 – 26.970 (1.0600 – 1.0618)	—	
Wheel rim runout	Axial	—	2.0 (0.08)	
	Radial	—	2.0 (0.08)	
Wheel axle runout	Front	—	0.25 (0.010)	
	Rear	—	0.25 (0.010)	
Tire size	Front	70/100-17 40M	RM85	—
		70/100-19 42M	RM85L	—
	Rear	90/100-14 49M	RM85	—
		90/100-16 52M	RM85L	—

SUSPENSION

Unit: mm (in)

ITEM	STANDARD		LIMIT
Front fork stroke	275 (10.8)		—
Front fork spring free length	—		444 (17.48)
Front fork spring rate (each leg)	2.8 N/mm (0.28 kgf/mm)		—
Front fork oil level	124 (4.88)		—
Front fork damping force adjuster	Rebound	1 and 1/2 turns out	—
	Compression	7 clicks out	—
Front fork air pressure	0 kPa (0 kgf/cm ² , 0 psi)		—
Rear shock absorber gas pressure	1 000 kPa (10 kgf/cm ² , 142 psi)		—
Rear shock absorber spring pre-set length	RM85: 3.1 mm (0.12 in) compressed from spring free length RM85L: 4.8 mm (0.19 in) compressed from spring free length		—
Rear shock absorber damping force adjuster	Rebound	2 turns out	—
	Compression	3/4 turns out	—
Rear shock absorber spring rate	RM85: 46 N/mm (4.6 kgf/mm) RM85L: 48 N/mm (4.8 kgf/mm)		
Rear wheel travel	277 (10.9)		—
Swingarm pivot shaft runout	—		0.3 (0.01)

TIRE PRESSURE

Front & Rear	70 – 110 kPa (0.7 – 1.1 kgf/cm ² , 10 – 16 psi)
--------------	---

FUEL + OIL + COOLANT

ITEM	SPECIFICATION		NOTE
Fuel type	Unleaded gasoline minimum 95 octane (RON)		
Fuel tank capacity	5.0 L (1.3/1.1 US/Imp gal)		
Engine oil type	MOTUL 800 2T or equivalent Two Cycle Racing Lubricant		
Air cleaner element oil type	MOTUL AIR FILTER OIL or equivalent filter oil		
Engine coolant type	Use an anti-freeze & Summer engine coolant compatible with aluminum radiator, mixed with distilled water only, at the ratio of 50:50.		
Engine coolant tank capacity	570 ml (1.20/1.00 US/Imp qt)		
Transmission oil type	SAE 10W-40, API SF/SG or SH/SJ with JASO MA		
Transmission oil capacity	Change	550 ml (1.16/0.97 US/Imp qt)	
	Overhaul	650 ml (1.37/1.14 US/Imp qt)	
Brake fluid type	DOT 4		
Front fork oil type	SUZUKI FORK OIL SS-05 or equivalent fork oil		
Front fork oil capacity (each leg)	351 ml (11.86/12.36 US/Imp oz)		
Rear shock absorber oil type	SUZUKI REAR SUSPENSION OIL SS-25 or an equivalent rear suspension oil		
Rear shock absorber oil capacity	195 ml (6.6/6.9 US/Imp oz)		

SPECIAL TOOLS

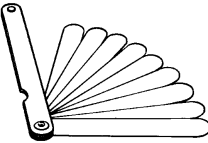
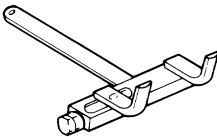
 <p>09900-00401 Hexagon wrench set</p>	 <p>09900-06107 Snap ring pliers</p>	 <p>09900-06108 Snap ring pliers</p>	 <p>09900-09003 Impact driver set</p>	 <p>09900-20101 Vernier calipers (150 mm)</p>
 <p>09900-20202 Micrometer (25 - 50 mm)</p>	 <p>09900-20205 Micrometer (0 - 25 mm)</p>	 <p>09900-20508 Cylinder gauge set</p>	 <p>09900-20602 Dial gauge</p>	 <p>09900-20605 Dial gauge</p>
 <p>09900-20803 Thickness gauge</p>	 <p>09900-25008 Multi circuit tester</p>	 <p>09910-20116 Conrod holder</p>	 <p>09910-32812 Crankshaft installer</p>	 <p>09910-60611 Universal clamp wrench</p>
 <p>09913-50121 Oil seal remover</p>	 <p>09913-70210 Bearing installer set</p>	 <p>09916-44910 Valve guide driver</p>	 <p>09916-53340 Valve guide installer</p>	 <p>09917-50410 Bearing remover</p>
 <p>09920-13120 Crankcase separating tool</p>	 <p>09920-20310 Spring hook</p>	 <p>09920-53740 Clutch sleeve hub holder</p>	 <p>09921-20220 Bearing remover set</p>	 <p>09923-73210 Bearing puller</p>

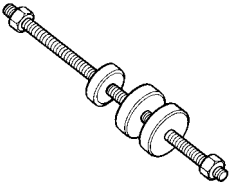
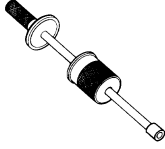
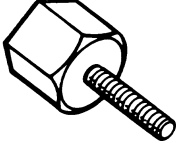
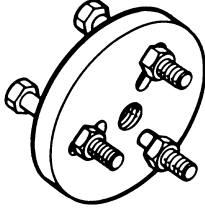
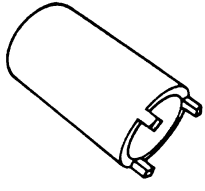
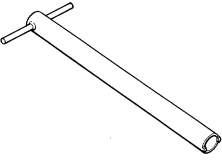
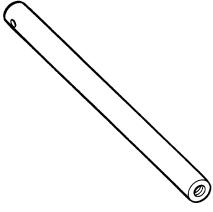
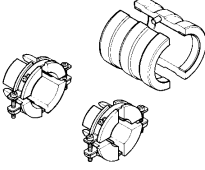
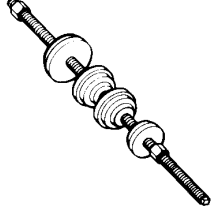
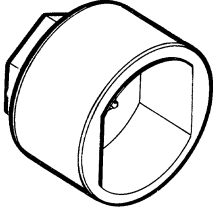
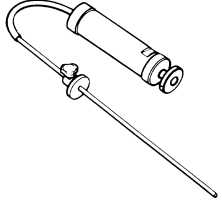
 <p>09924-84521 Bearing installer</p>	 <p>09930-30102 Rotor remover slide shaft</p>	 <p>09930-30141 Flywheel rotor remover, Attachment A</p>	 <p>09930-30211 Flywheel rotor remover, Attachment C</p>	 <p>09940-14930 Steering nut socket wrench</p>
 <p>09940-30250 Front fork assembling</p>	 <p>09940-52841 Inner rod holder</p>	 <p>09940-52861 Front fork oil seal installer set</p>	 <p>09941-34513 Bearing installer set</p>	 <p>09941-53630 Rear shock absorber wrench</p>
 <p>09943-74111 Front fork oil level gauge</p>				

WIRE, CABLE AND HOSE ROUTING

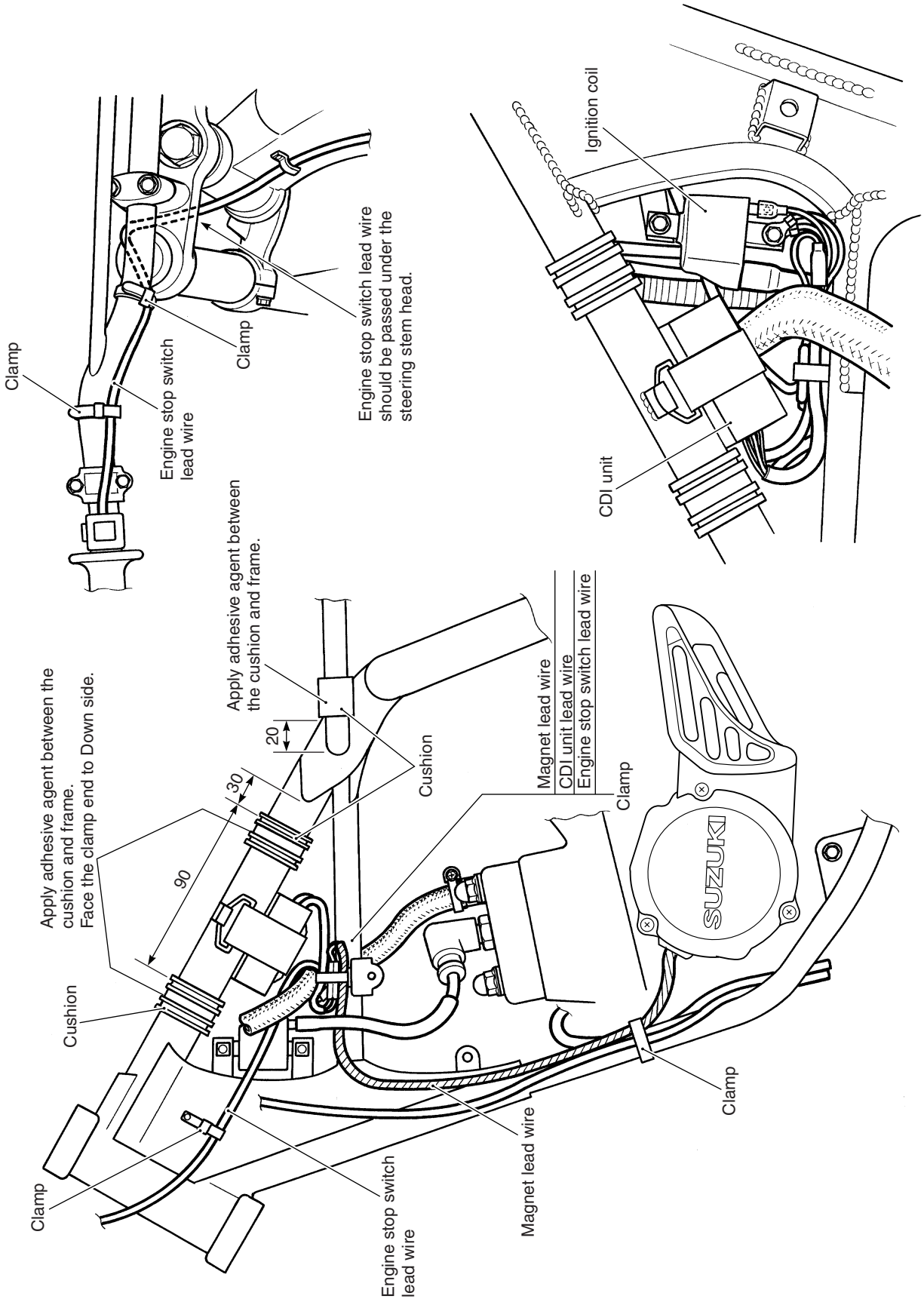

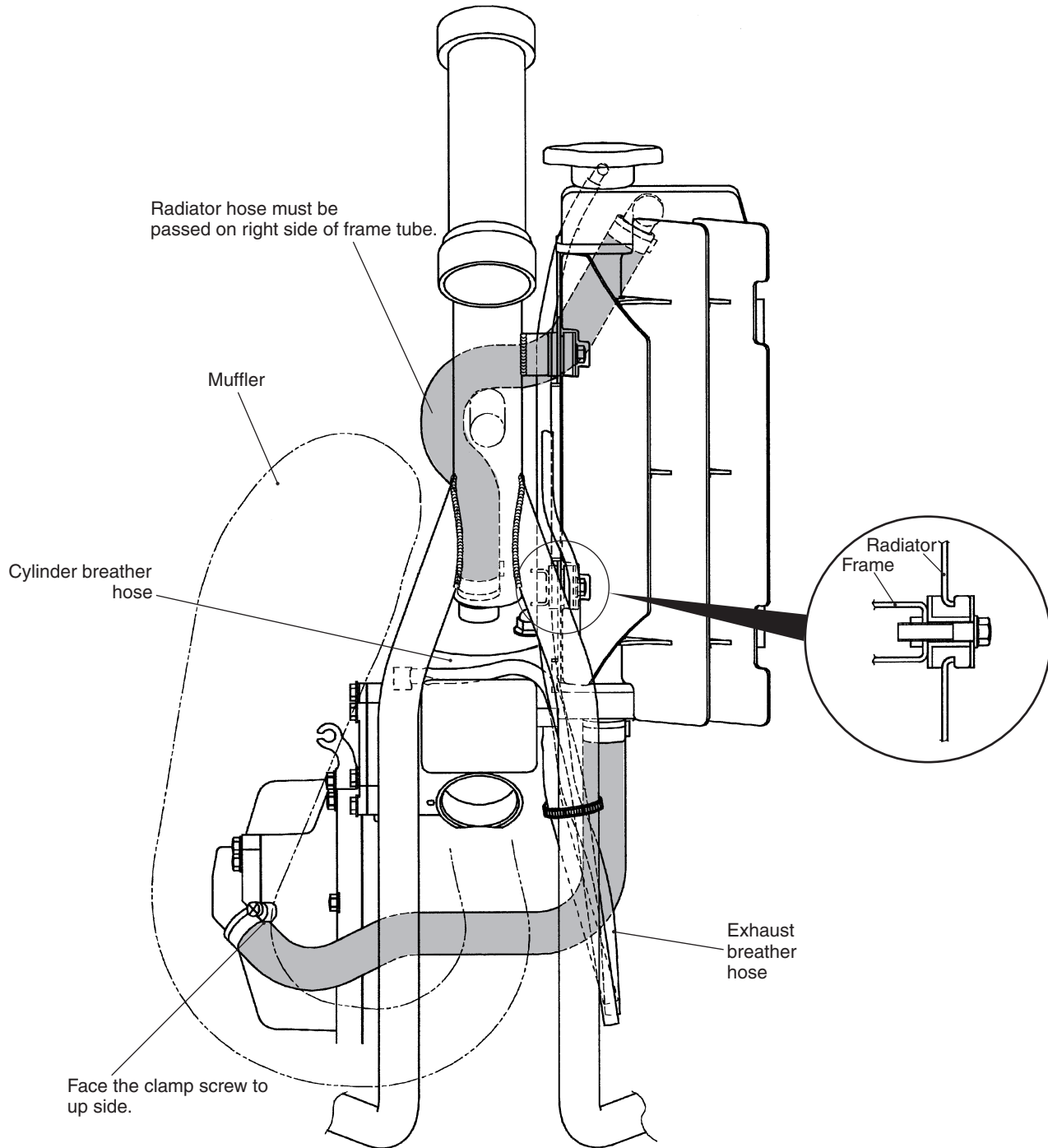

VIEW OF A

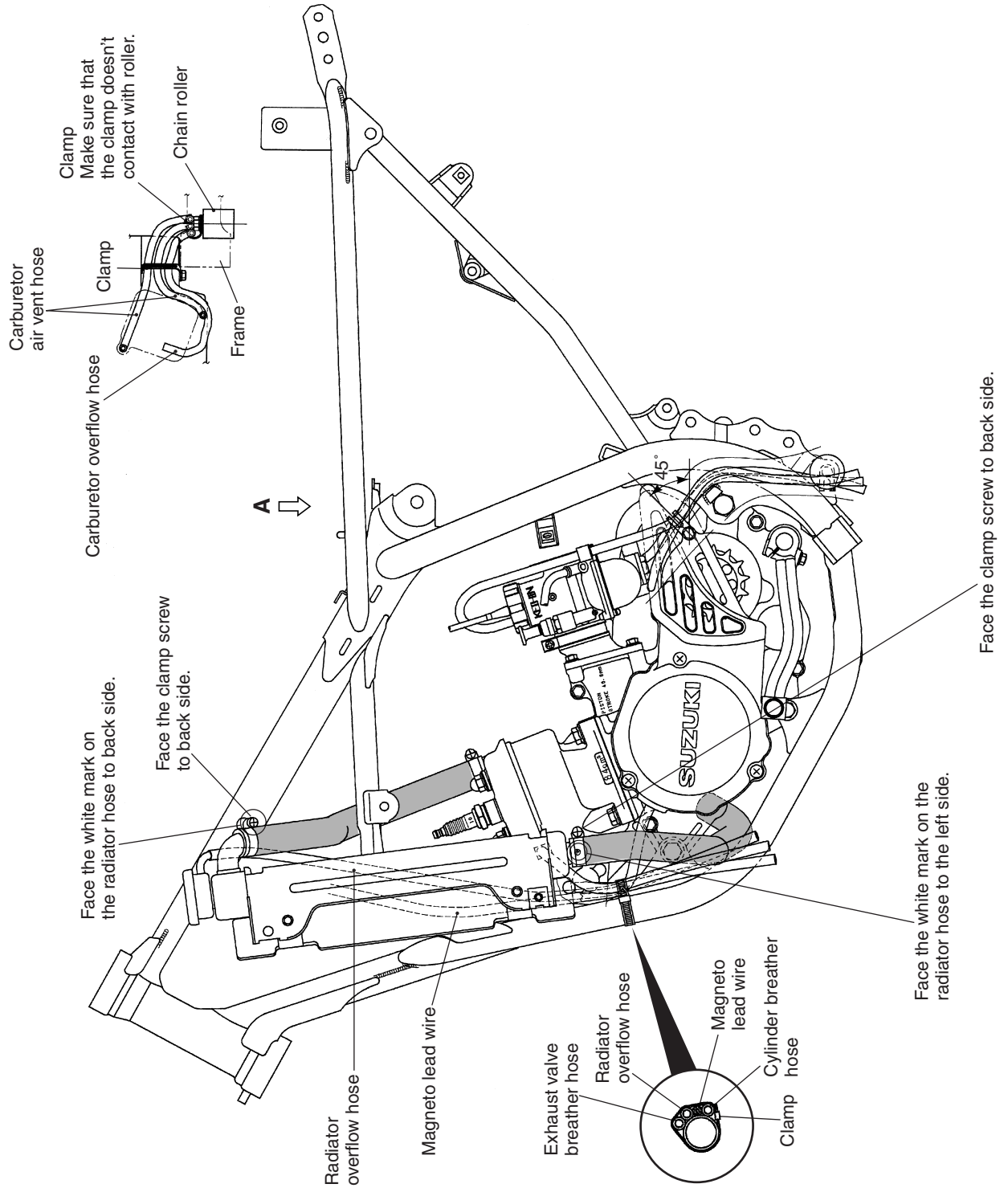

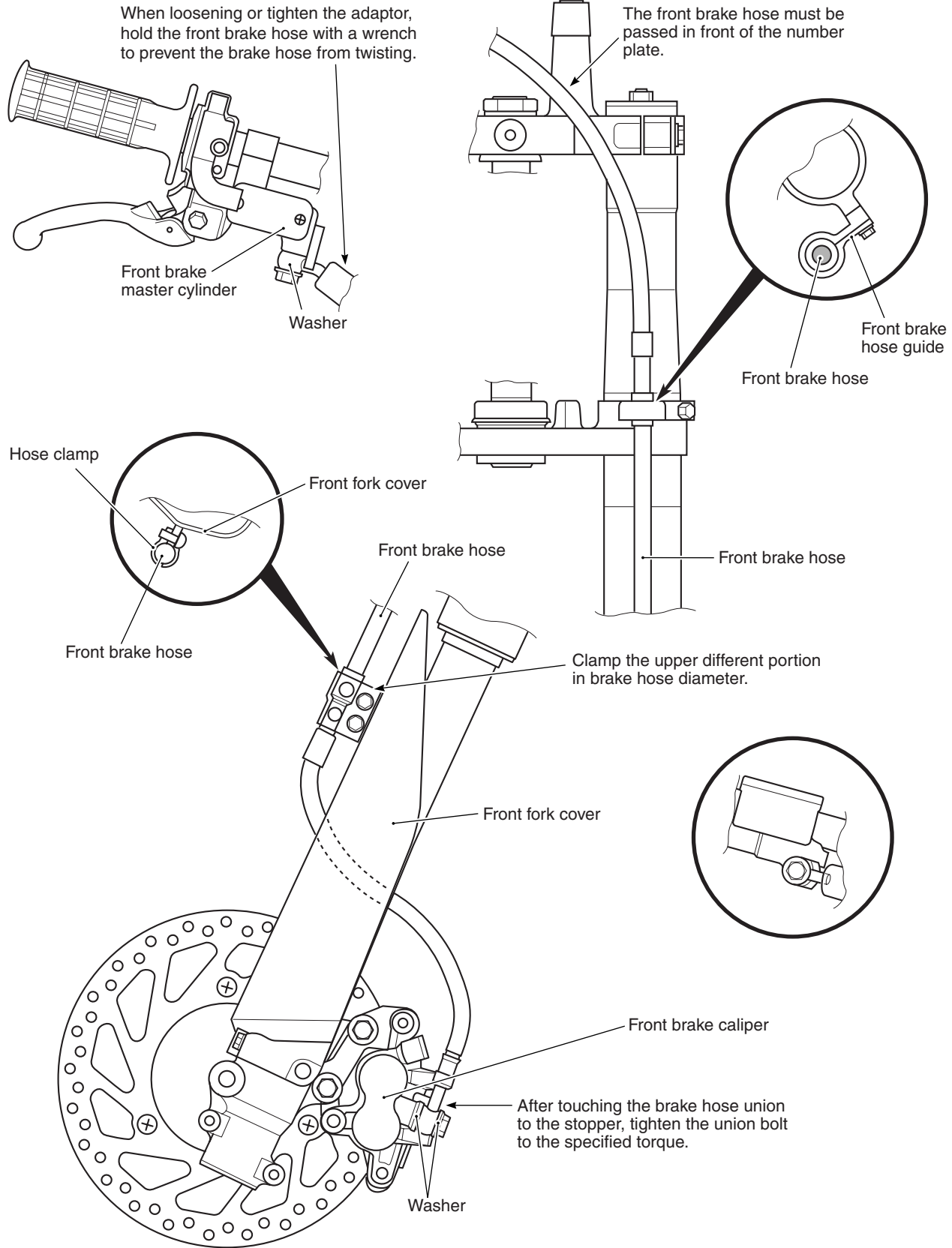

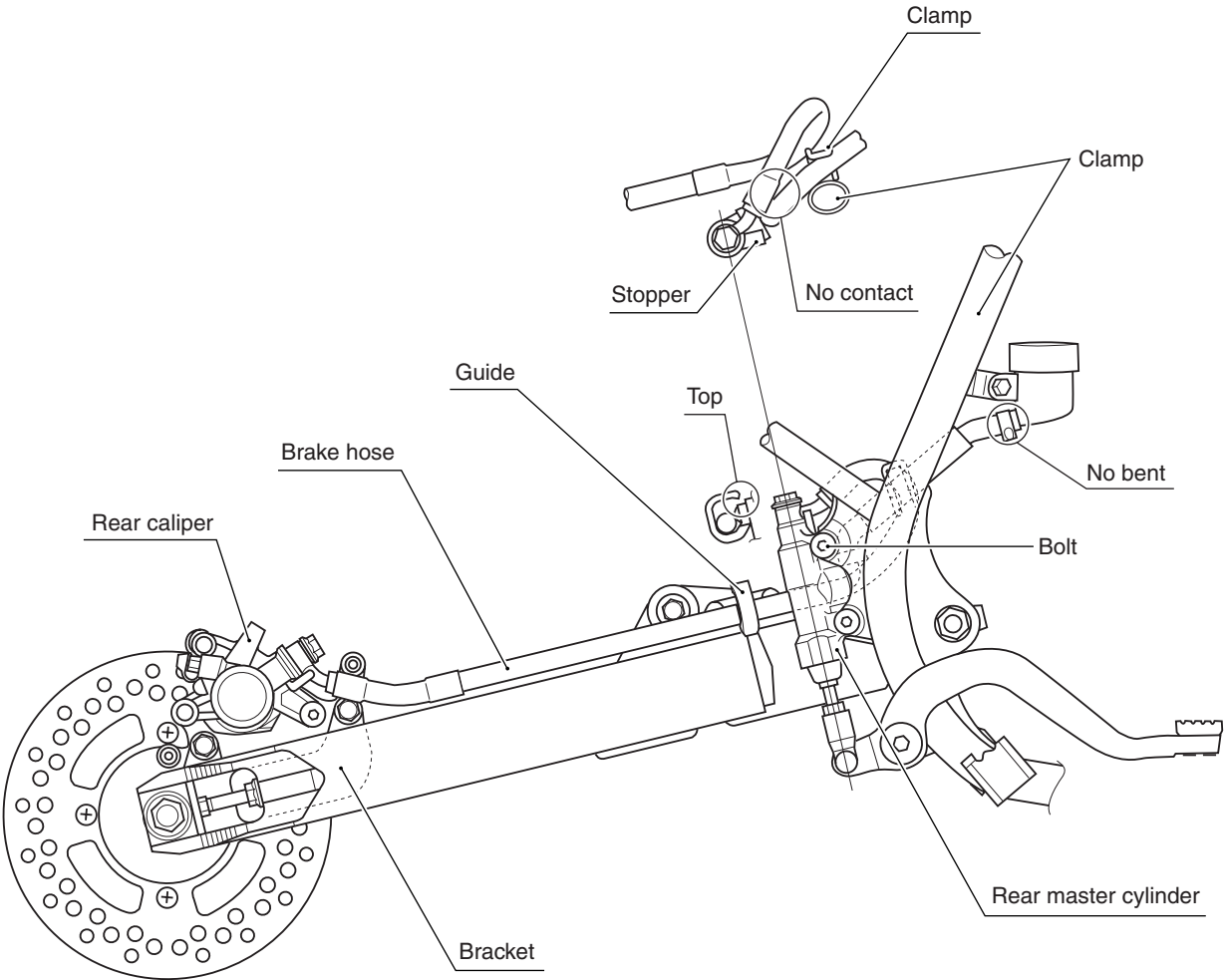

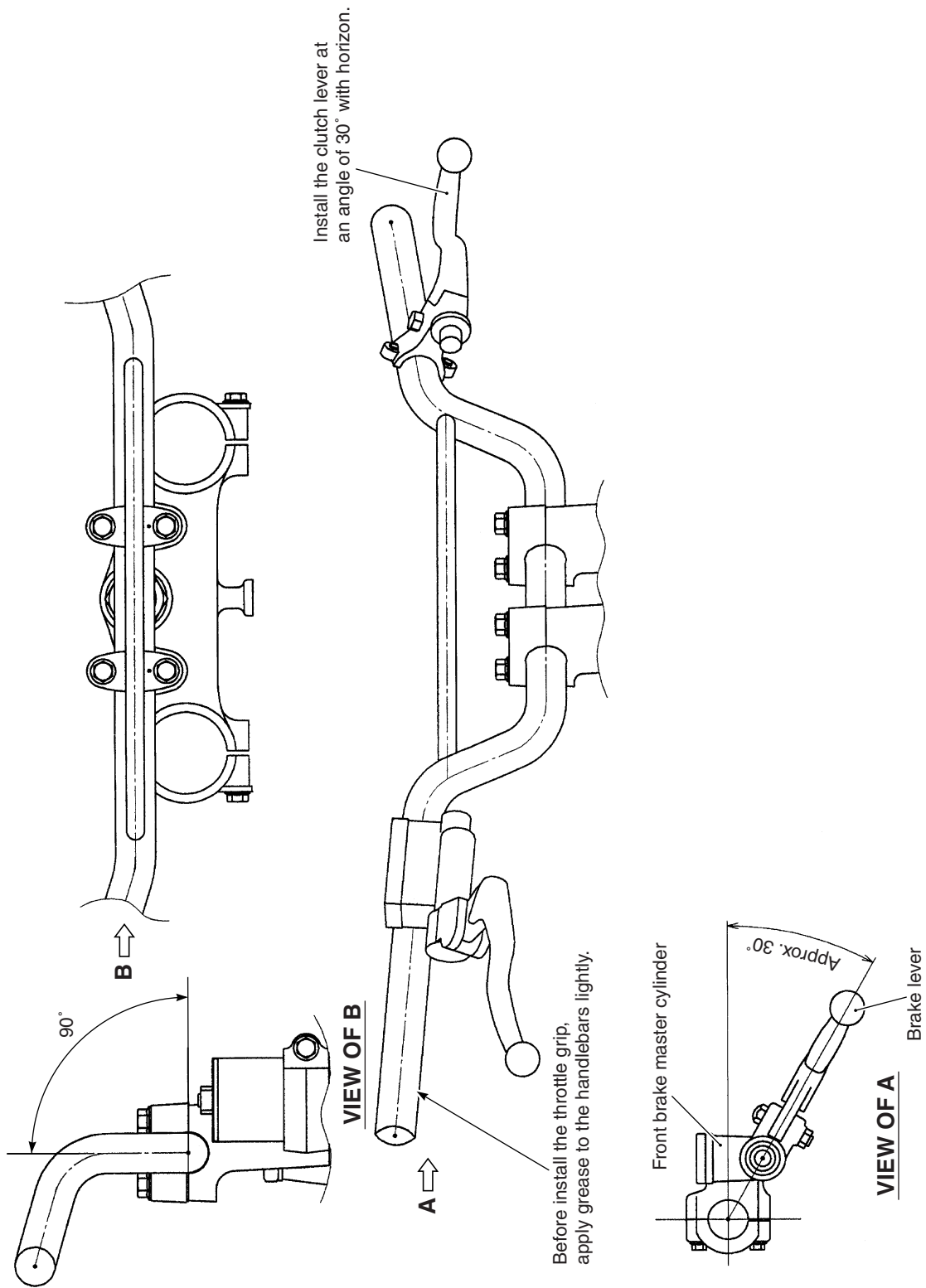

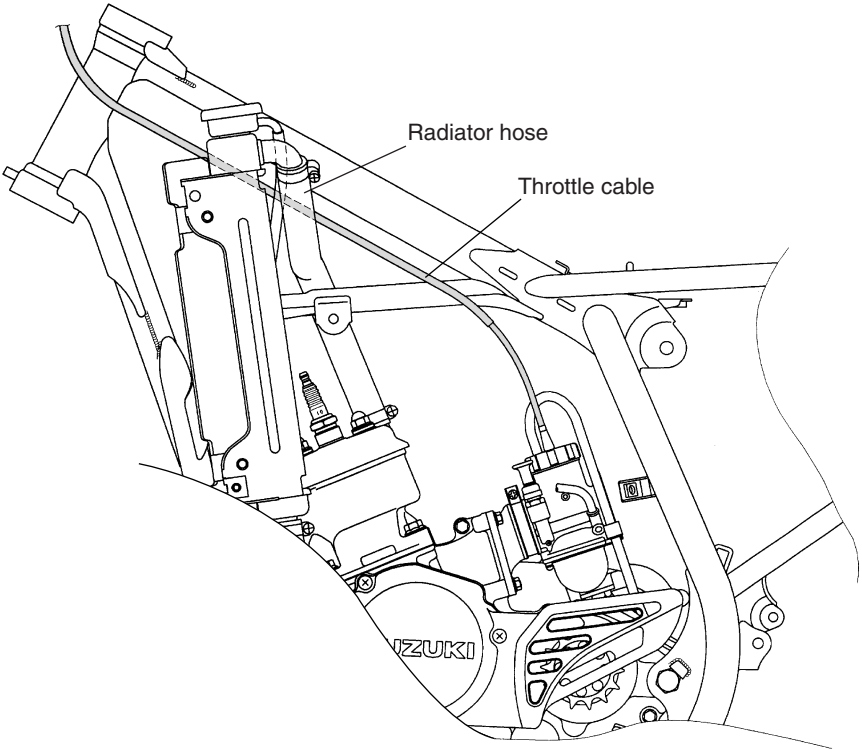
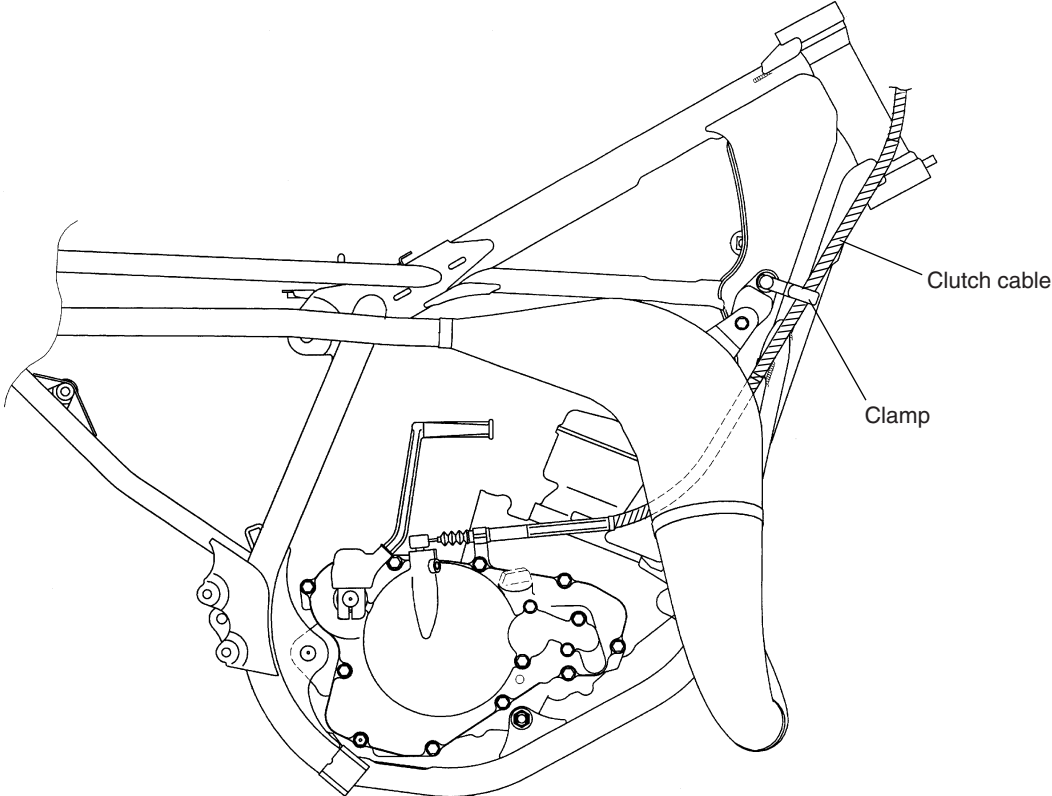

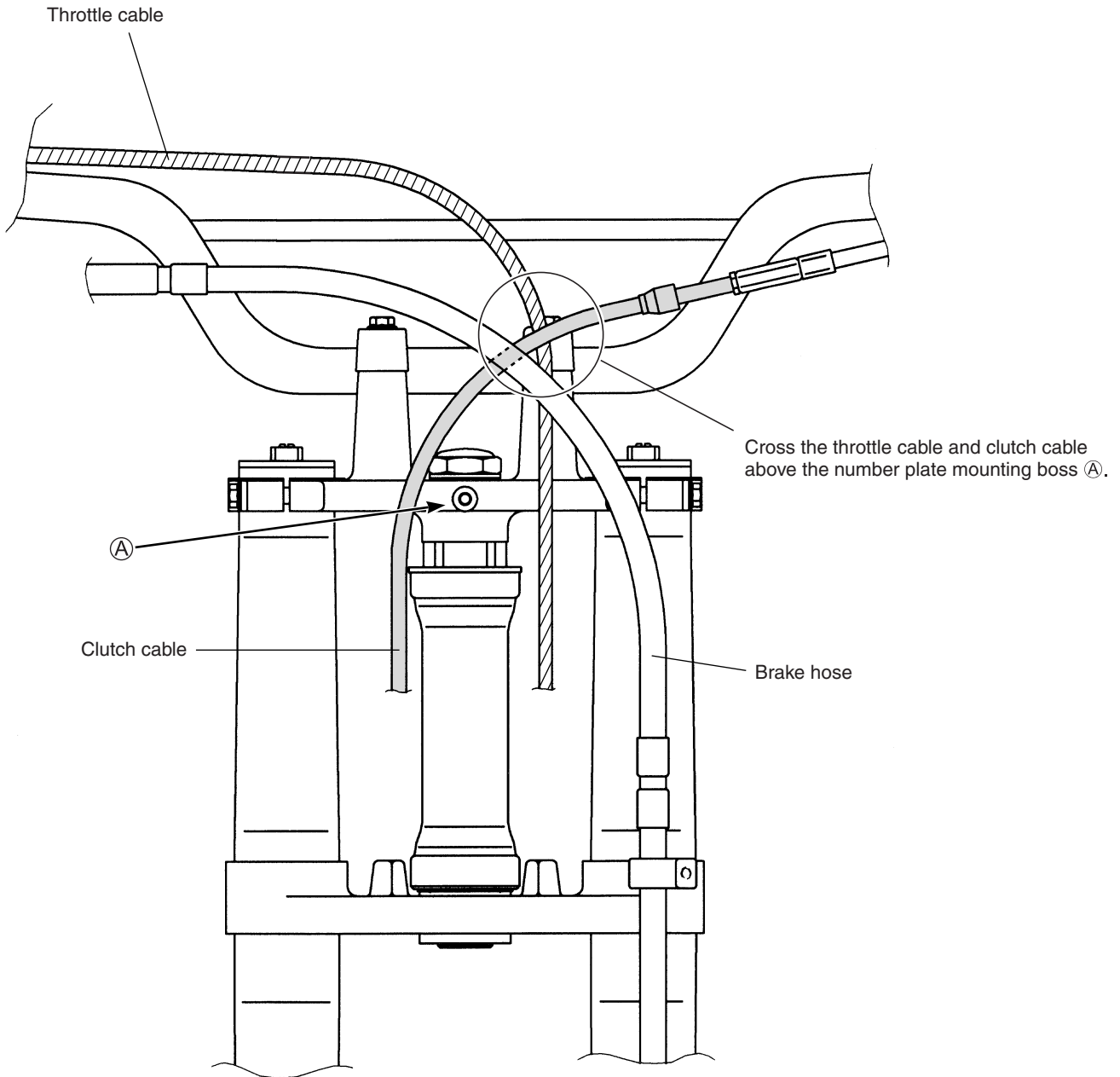

SPECIFICATIONS

DIMENSIONS AND DRY MASS

Overall length	1 805 mm (71.1 in)	RM85
	1 895 mm (74.6 in)	RM85L
Overall width.....	735 mm (28.9 in)	
Overall height	1 100 mm (43.3 in)	RM85
	1 165 mm (45.9 in)	RM85L
Wheelbase	1 240 mm (48.8 in)	RM85
	1 280 mm (50.4 in)	RM85L
Ground clearance.....	325 mm (12.8 in)	RM85
	355 mm (14.0 in)	RM85L
Seat height.....	850 mm (33.5 in)	RM85
	875 mm (34.4 in)	RM85L
Dry mass	65 kg (143 lbs)	RM85
	69 kg (152 lbs)	RM85L

ENGINE

Type.....	Two-stroke, liquid-cooled
Intake system	Crankcase reed valve
Number of cylinders	1
Bore.....	48 mm (1.890 in)
Stroke	46.8 mm (1.843 in)
Displacement	84.7 cm ³ (5.2 cu. in)
Corrected compression ratio	9.5 : 1 (EX VALVE OPEN)
	10.9 : 1 (EX VALVE CLOSE)
Carburetor	KEIHIN PE28, Single
Air cleaner	Polyurethane foam element
Starter system	Primary kick
Lubrication system	Fuel/oil premixture of 30 : 1

TRANSMISSION

Clutch	Wet multi-plate type	
Transmission	6-speed constant mesh	
Gearshift pattern	1-down, 5-up	
Primary reduction ratio.....	3.444 (62/18)	
Gear ratios, Low	2.545 (28/11)	
2nd	1.933 (29/15)	
3rd	1.571 (22/14)	
4th	1.333 (20/15)	
5th	1.166 (21/18)	
Top.....	1.045 (23/22)	
Final reduction ratio.....	3.357 (47/14)	RM85
	3.615 (47/13)	RM85L
Drive chain	D.I.D 428DS, 118 links	RM85
	D.I.D 428DS, 122 links	RM85L

CHASSIS

Front suspension	Telescopic, pneumatic/coil spring, oil damped
Rear suspension	Link type, oil damped
Front fork stroke	275 mm (10.8 in)
Rear wheel travel	277 mm (10.9 in)
Caster	28° 30' RM85
	28° RM85L
Trail	87 mm (3.4 in) RM85
	85 mm (3.3 in) RM85L
Steering angle.....	45°
Turning radius	1.9 m (6.2 ft) RM85
	2.0 m (6.6 ft) RM85L
Front brake.....	Disc brake, hydraulically operated
Rear brake	Disc brake, hydraulically operated
Front tire size	70/100-17 40M RM85
	70/100-19 42M RM85L
Rear tire size.....	90/100-14 49M RM85
	90/100-16 52M RM85L

ELECTRICAL

Ignition type.....	Electronic Ignition (CDI)
Ignition timing.....	15° B.T.D.C. at 11 000 r/min
Spark plug.....	NGK BR10ES

CAPACITIES

Fuel tank	5.0 L (1.3/1.1 US/Imp gal)
Transmission oil	650 ml (1.4/1.1 US/Imp qt)
Engine coolant	570 ml (1.2/1.0 US/Imp qt)
Front fork oil	351 ml (11.86/12.36 US/Imp oz)

SETTING DATA

EVENT	DATE/ LOCATION	DATE	/ /	/ /	/ /
		RACE/COURSE	/	/	/
		TEMP./HUMIDITY	/	/	/
		WHETHER			
		COURSE COUDITION			
ENGINE	CARBURETOR	MAIN JET			
		JET NEEDLE	/	/	/
		SLOW JET			
		PILOT SCREW			
		FLOAT LEVEL			
	SPARK PLUG				
CHASSIS	FRONT FORK	OIL LEVEL	mm	mm	mm
		COMP. ADJ. POSITION			
		RE-BOUND ADJ. POSITION			
		SPRING			
	REAR SUSPENSION	SPRING			
		SPRING SET LENGTH	mm	mm	mm
		SUG	mm	mm	mm
		COMP. ADJ. POSITION LOW			
		COMP. ADJ. POSITION HIGH			
		RE-BOUND ADJ. POSITION			
	FINAL REDUCTION RATIO		/	/	/
	FRONT TIRE	MAKER/SIZE			
		PRESSURE	kPa	kPa	kPa
	REAR TIRE	MAKER/SIZE			
		PRESSURE	kPa	kPa	kPa
	COMMENT:				

*MAKE COPIES.

- MEMO -

WARNING

Failure to follow these safety precautions may increase your risk of injury:

- **Wear a helmet, eye protection, and bright protective clothing.**
- **Don't ride after consuming alcohol or other drugs.**
- **This owner's service manual contains important safety information. Please read it carefully.**

K7

SUZUKI MOTOR CORPORATION
300 TAKATSUKA, HAMAMATSU, JAPAN



* 9 9 0 1 1 - 0 2 B 8 2 - 0 1 A *

Printed in Taiwan