

HONDA

SERVICE MANUAL

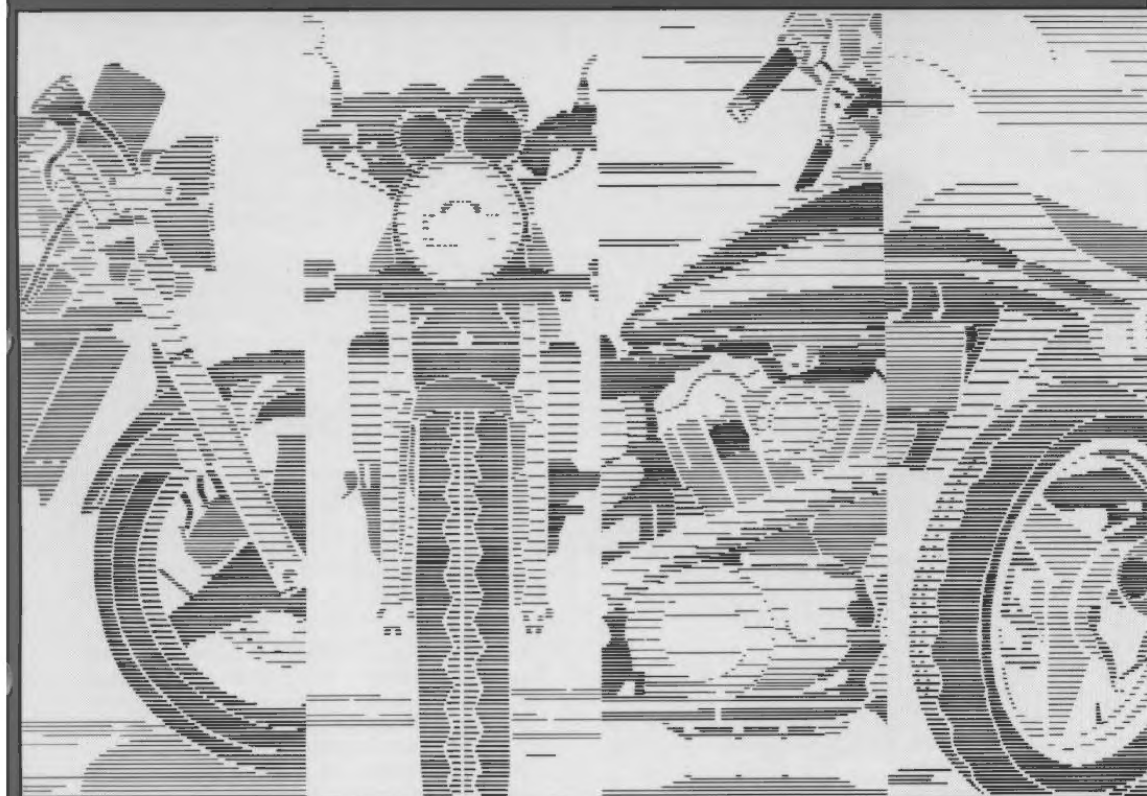

91-94
CBR600F2

Introduction

This service manual describes the service procedures for the CBR600F2.

This Model Specific Manual includes every service procedure that is of a specific nature to this particular model. Basic service procedures that are common to other Honda Motorcycle/Motor Scooter/ATVs are covered in the Common Service Manual. This Model Specific Service Manual should be used together with the Common Service Manual in order to provide complete service information on all aspects this motorcycle.

CODE	AREA (TYPE)	CODE	AREA (TYPE)
A	49 state	CM	Canada
AC	California		

Follow the Maintenance Schedule (Section 3) recommendations to ensure that the vehicle is in peak operating condition and the emission levels are within the standards set by the U.S. Environmental Protection Agency and the California Air Resources Board.

Performing the first scheduled maintenance is very important. It helps compensate for the initial wear that occurs during the break-in period.

Section 1 and 3 apply to the whole motorcycle, section 2 illustrates procedures for removal/installation of components that may be required to perform service and describes parts of the motorcycle, grouped according locations.

Find the section you want on this page, then turn the table of contents on the first page of the section.

Most sections describe the service procedures through system illustrations. Refer to the next page for details on how to use this manual.

If you don't know the source of the trouble, go to section 20 Troubleshooting.

All information, illustrations, directions and specifications included in this publication are based on the latest product information available at the time of approval for printing. HONDA MOTOR CO., LTD. reserves the right to make changes at any time without incurring any obligation whatever. No part of this publication may be reproduced without written permission. This manual is written for persons who have acquired basic knowledge of maintenance on HONDA motorcycles, motor scooters or ATVs.

HONDA MOTOR CO., LTD.
SERVICE PUBLICATION OFFICE

Contents

	General Information	1	
	Frame/Body Panels/Exhaust System	2	
	Maintenance	3	
Engine and Drive Train	Lubrication System	4	
	Cooling System	5	
	Fuel System	6	
	Engine Removal/Installation	7	
	Cylinder Head	8	
	Clutch/Gearshift Linkage	9	
	Crankcase/Cylinder/Piston	10	
	Crankshaft/Transmission	11	
	Chassis	Front Wheel/Suspension/Steering	12
		Rear Wheel/Suspension	13
Brake System		14	
Electrical	Charging System/Alternator	15	
	Ignition System	16	
	Electric Starter/Starter Clutch	17	
	Lights/Meters/Switches	18	
	Wiring Diagram	19	
	Troubleshooting	20	
	Index	21	

Important Safety Notice

▲WARNING Indicates a strong possibility of severe personal injury or death if instructions are not followed.















CAUTION: Indicates a possibility of equipment damage if instructions are not followed.

NOTE: Gives helpful information.

Detailed descriptions of standard workshop procedures, safety principles and service operations are not included. It is important to note that this manual contains *some* warnings and cautions against some specific service methods which could cause **PERSONAL INJURY** to service personnel or could damage a vehicle or render it unsafe. Please understand that those warnings could not cover all conceivable ways in which service, whether or not recommended by Honda, might be done or of the possibly hazardous consequences of each conceivable way, nor could Honda investigate all such ways. Anyone using service procedures or tools, whether or not recommended by Honda, *must satisfy himself thoroughly* that neither personal safety nor vehicle safety will be jeopardized by the service methods or tools selected.

Symbols

The symbols used throughout this manual show specific service procedures. If supplementary information is required pertaining to these symbols, it would be explained specifically in the text without the use of the symbols.

	Replace the part(s) with new one(s) before assembly.
	Use special tool.
	Use optional tool. Use the same procedure you use to order parts.
 10 (1.0, 7.2)	Torque specification 10 N·m (1.0 kg-m, 7.2 ft-lb).
	Use recommended engine oil, unless otherwise specified.
	Use molybdenum oil solution (mixture of engine oil and molybdenum grease in a ratio of 1 : 1).
	Use multi-purpose grease (Lithium based multi-purpose grease NLGI #2 or equivalent).
	Use molybdenum disulfide grease (containing more than 3% molybdenum disulfide, NLGI #2 or equivalent). Example: Molykote® BR-2 plus manufactured by Dow Corning, U.S.A. Multi-purpose M-2 manufactured by Mitsubishi Oil Japan
	Use molybdenum disulfide paste (containing more than 40% molybdenum disulfide, NLGI #2 or equivalent). Example: Molykote® G-n Paste manufactured by Dow Corning, U.S.A. Honda Moly 60 (U.S.A. only) Rocol ASP manufactured by Rocol Limited, U.K. Rocol Paste manufactured by Sumico Lubricant, Japan
	Use silicone grease.
	Apply a locking agent. Use a middle strength locking agent unless otherwise specified.
	Apply sealant.
	Use brake fluid DOT 4. Use the recommended brake fluid, unless otherwise specified.
	Use Fork or Suspension Fluid.

How to Use This Manual

Finding The Information You Need

- This manual is divided into sections which cover each of the major components of the motorcycle.
- To quickly find the section you are interested in, the first page of each section is marked with a black tab that lines up with one of the thumb index tabs before this page.
- The first page of each section lists the table of contents within the section.
- Read the service information and troubleshooting related to the section before you begin working.
- An index of the entire book is provided in the last chapter to directly locate the information you need.

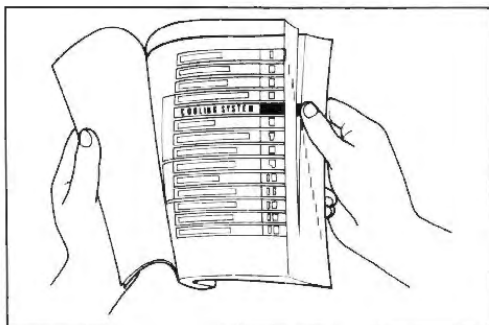

Understanding The Instructions

- The removal and installation of parts are for the most part illustrated by large and clear illustrations that should provide the reader with visual aid in understanding the major point for servicing.
- The system illustrations are augmented by callouts whose numbers or letters indicate the order in which the parts should be removed or installed.
- The sequence of steps represented numerically are differentiated from the ones represented alphabetically to notify the reader that they must perform these steps separately.
- For example, if the steps prior and up to camshaft removal are performed with the engine installed, but the subsequent steps like cylinder head removal require engine removal, the callouts are grouped in numerical and alphabetical orders.
- The illustrations may contain symbols to indicate necessary service procedures and precautions that need to be taken. Refer to the next page for the meaning of each symbol mark.
- Also in the illustration is a chart that lists information such as the order in which the part is removed/installed, the name of the part, and some extra notes that may be needed.
- Step by step instructions are provided to supplement the illustrations when detailed explanation of the procedure is necessary or illustrations alone would not suffice.
- Service procedures required before or after the procedure described on that particular page, or inspection/adjustment procedures required following the installation of parts, are described under the title Requisite Service.
- Standard workshop procedures and knowledge covered in the Common Service Manual are abbreviated in this manual.

Symbols

System illustration

Step sequence (numerals or letters)

Part name

Number of parts

Extra notes or precautions related to the service procedure

CYLINDER HEAD/CYLINDER PISTON

CYLINDER HEAD REMOVAL/INSTALLATION

REQUISITE SERVICE

Engine removal/Installation: page 8-2

REMOVAL ORDER

1. Cylinder head seal ring
2. Cylinder head mounting bolt
3. Cylinder head assembly
4. Seal ring
5. Shim ring
6. Camshaft idle gear case
7. Camshaft idle gear case bolt
8. Camshaft idle gear case nut
9. Spring cone
10. Camshaft nut

INSTALLATION ORDER

1. Camshaft nut
2. Spring cone
3. Camshaft idle gear case nut
4. Camshaft idle gear case bolt
5. Shim ring
6. Seal ring
7. Cylinder head assembly
8. Cylinder head mounting bolt
9. Cylinder head seal ring

REMARKS

Installation is in the reverse order of removal.

Installation page 8-5

Always use the LP head facing up as indicated.

Installation page 8-5

All installation steps must be done with the engine off and the left side valve cover removed.

CAMSHAFT IDLE GEAR CASE INSTALLATION

Install the camshaft idle gear case assembly as shown.

NOTE

Without the Shim ring installed, the camshaft idle gear case may be too loose after the crank shaft timing gear.

Install the camshaft idle gear case on the crank shaft timing gear with the Shim ring. Use only the gear case because it has a design camshaft center.

Install it in the timing cover and push the Shim ring into it as shown in the figure.

CYLINDER HEAD NUT BOLT INSTALLATION

Use of the Cylinder Head seal ring is optional. Do not tighten them yet.

Install the cylinder head mounting bolts.

Tighten the upper nuts and mounting bolts in a diagonal clockwise pattern.

TORQUE

Shim ring bolt: 30 N·m (22 ft·lb)

Mounting bolt: 12 N·m (9 ft·lb)

CYLINDER HEAD/CYLINDER PISTON

REMOVAL

1. BOLT
2. SPRING CONE
3. CAMSHAFT IDLE GEAR CASE NUT
4. SHIM RING
5. SEAL RING
6. CYLINDER HEAD MOUNTING BOLT
7. CYLINDER HEAD ASSEMBLY
8. CYLINDER HEAD SEAL RING

INSTALLATION

1. BOLT
2. SPRING CONE
3. CAMSHAFT IDLE GEAR CASE NUT
4. SHIM RING
5. SEAL RING
6. CYLINDER HEAD MOUNTING BOLT
7. CYLINDER HEAD ASSEMBLY
8. CYLINDER HEAD SEAL RING

2. Frame/Body Panels/Exhaust System

Service Information	2-1	Front Cowl Disassembly/Assembly	2-6
Troubleshooting	2-1	Rear Fender B Removal/Installation	2-7
Side Cover Removal/Installation	2-2	Tail Cowl Removal/Installation	2-7
Seat Removal/Installation	2-2	Rear Fender A Removal/Installation	2-8
Side Fairing Removal/Installation	2-3	Exhaust System Removal/Installation	2-10
Front Cowl Removal/Installation	2-4	Fuel Tank Removal/Installation	2-11

Service Information

▲ WARNING

- Gasoline is extremely flammable and explosive under certain conditions.
- Serious burns may result if the exhaust system is not allowed to cool before components are removed or serviced.

- Work in a well ventilated area. Smoking or allowing flames or sparks in the working area or where gasoline is stored can cause a fire or explosion.
- This section covers removal and installation of the frame body panels, fuel tank and exhaust system.
- Frame body panel installation is in the reverse order of removal, unless noted otherwise.
- When removing the cover, be careful not to damage any tab or groove of a cover.
- Always replace the exhaust pipe gaskets when removing the exhaust pipe from the engine.
- When installing the exhaust pipe, install all the fasteners loosely. Always tighten the exhaust clamps first, then tighten the mounting fasteners. If you tighten the mounting fasteners first, the exhaust pipe may not seat properly.
- Always inspect the exhaust system for leaks after installation.

Troubleshooting

Excessive Exhaust Noise

- Broken exhaust system
- Exhaust gas leak

Poor Performance

- Deformed exhaust system
- Exhaust gas leak
- Clogged muffler

Side Cover Removal/Installation

Unlock the quick release fasteners by aligning the long slot with the punch mark.

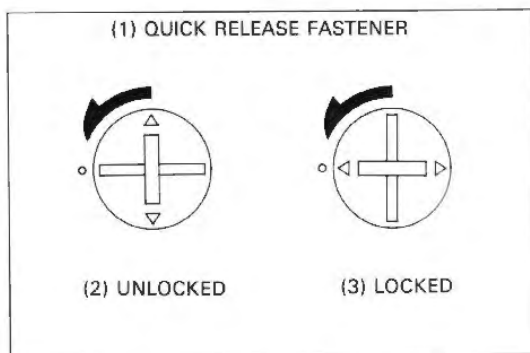

Remove the side cover by releasing the bosses on the cover from the grommets.

CAUTION

- Be careful not to break the pins, tabs and slots in the side cover and tail cowl when removing the side cover.

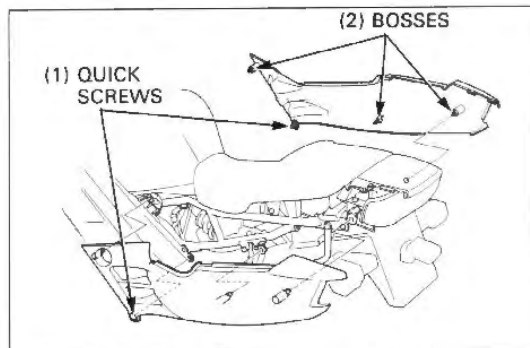

Install the side cover aligning its bosses with the grommets and engage the tabs with the slots, and pins with the holes securely as shown.

Lock the clip by aligning the "△" mark with the punch mark. Do the same on the other side.

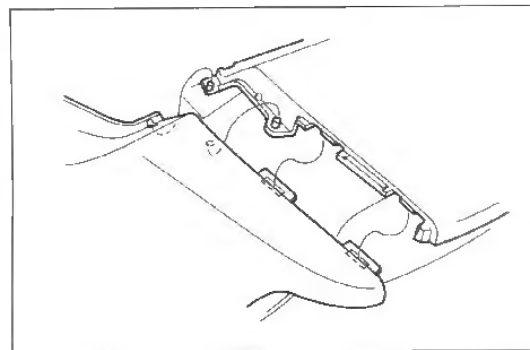

Seat Removal/Installation

Remove the side covers.

Remove the seat by removing the bolts and sliding the seat back.

Install the seat in the reverse order of removal, then install the side covers.

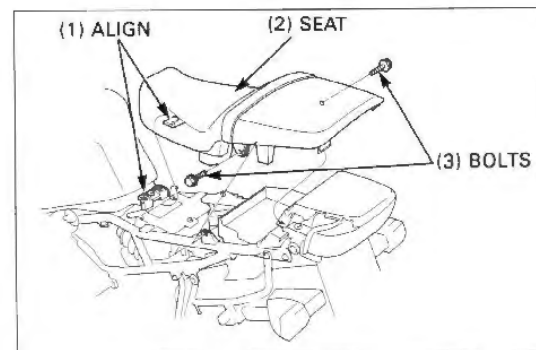

Side Fairing Removal/Installation

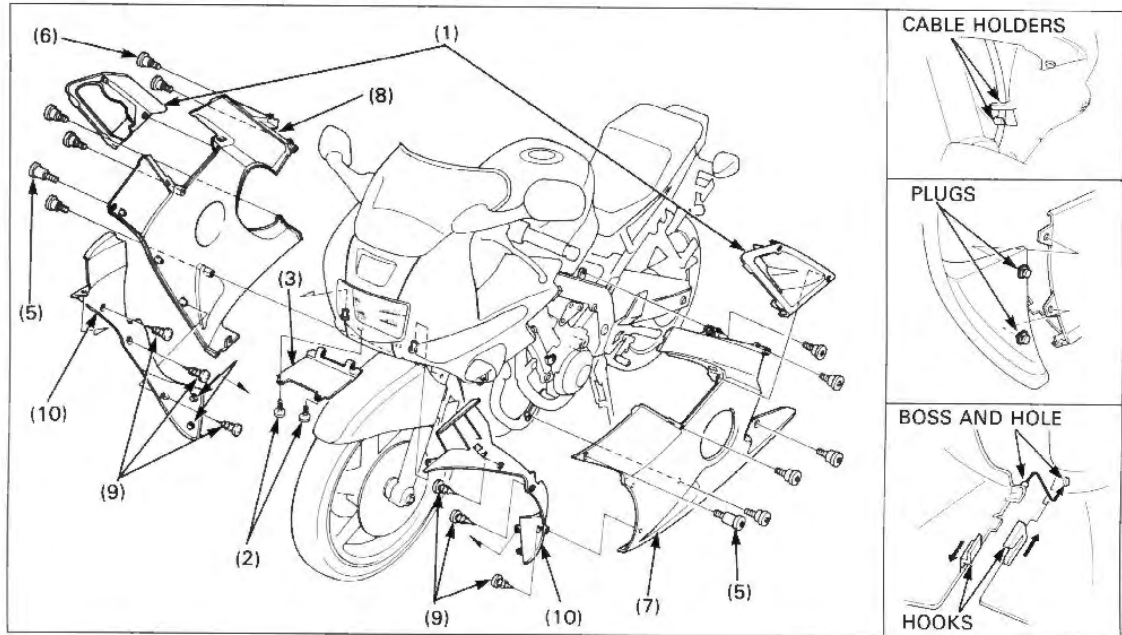

Requisite Service

- Side cover removal/installation (page 2-2)

Procedure	Q'ty	Remarks
Removal Order		Installation is in the reverse order of removal.
(1) Maintenance cover	2	
(2) Tapping screw	2	
(3) Headlight lower cover	1	Release the claws from the front cowl stay. Be careful not to break off the claws.
(4) Retaining plug	2	
(5) Hex bolt (long)	2	
(6) Hex bolt (short)	10	
(7) Left side fairing	1	NOTE
		<ul style="list-style-type: none"> • Separate the left side fairing from the right one by disengaging the hooks on the bottom of the fairings. • When assembling the side fairings, align the boss on the left side fairing with the hole in the right one. • Left and right side fairings can be removed without removing the side fairing inner covers.
(8) Right side fairing	1	Replace the speedometer cable from the cable holder on the inner cover.
(9) Self-tapping screw	6	
(10) Side fairing inner cover (right/left)	1/1	

Front Cowl Removal/Installation

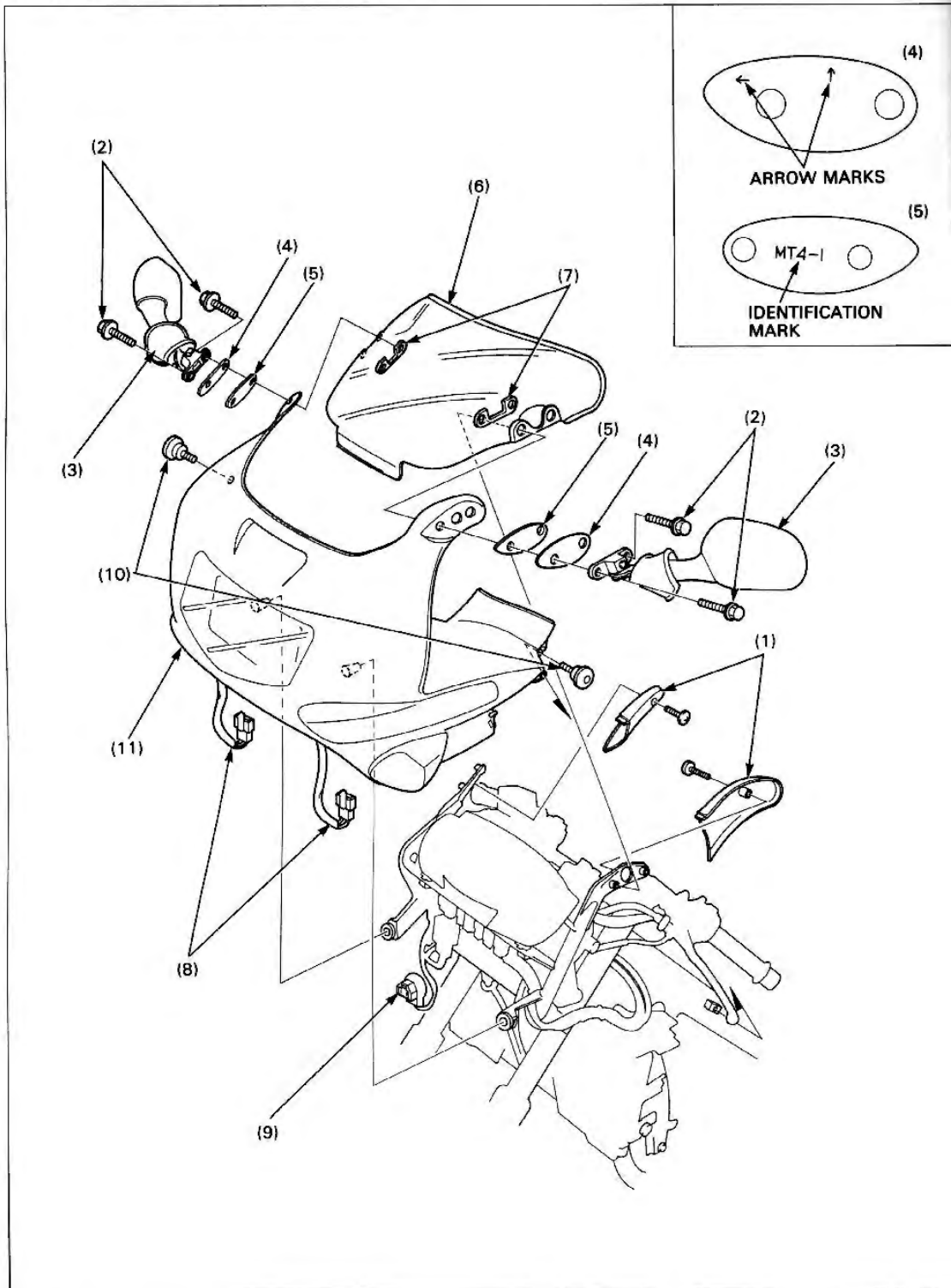

Requisite Service

- Side fairing removal/installation (page 2-3)

Procedure	Q'ty	Remarks
Removal Order (1) Rear view mirror inner cover (2) Bolt (3) Rear view mirror (right/left) (4) Seat rubber plate (5) Seat rubber (6) Wind screen (7) Seat rubber (8) Front turn signal connector (3P mini) (9) Headlight socket (10) Hex bolt (11) Front cowl	1/1 4 1/1 2 2 1 2 2 1 2 1	
Installation Order (11) Front cowl (10) Hex bolt (9) Headlight socket (8) Front turn signal connector (3P mini) (7) Seat rubber (6) Wind screen (5) Seat rubber (4) Seat rubber plate (3) Rear view mirror (right/left) (2) Bolt (1) Rear view mirror inner cover	1 2 1 2 2 1 2 2 1/1 4 1/1	Align the bosses on the headlight case with the grommets. Install the right seat rubber with the mark "MT4-R" facing in. Install the left seat rubber with the mark "MT4-L" facing in. Install the right plate with the marked side in and each arrow mark pointing forward and up. Install the left plate with the marked side out and each arrow mark pointing forward and up.

Front Cowl Disassembly/Assembly

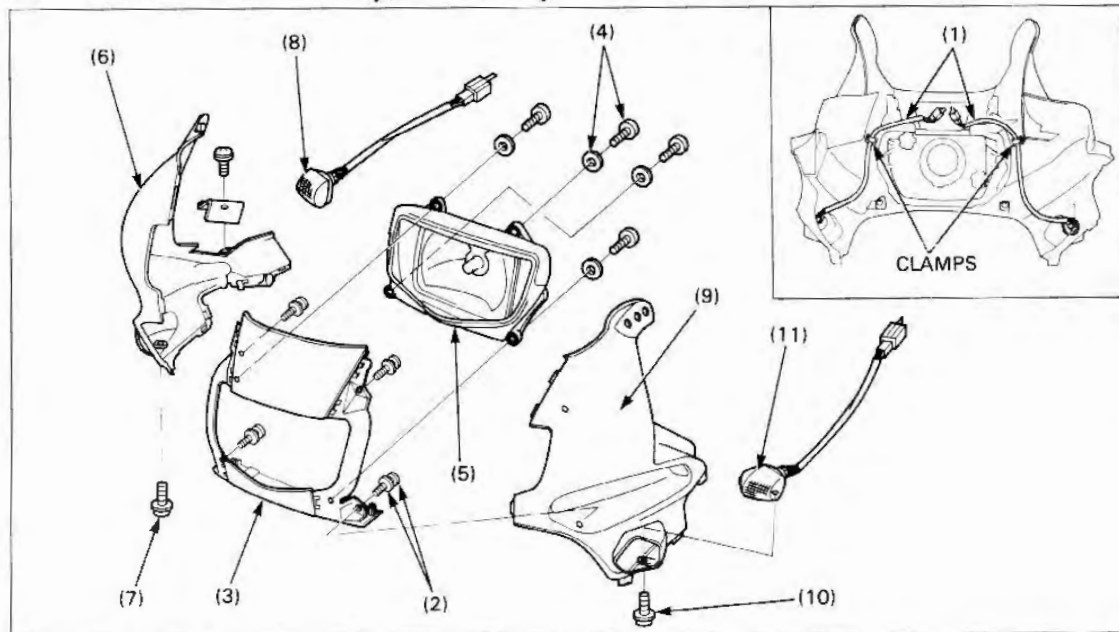

Requisite Service

- Front cowl removal/installation (page 2-4)

Procedure	Q'ty	Remarks
Disassembly Order		
(1) Turn signal wire	2	Assembly is in the reverse order of disassembly. Release the wires from the clamps. After assembling the front cowl, route and clamp the wires as shown.
(2) Screw/washer	4/4	
(3) Center front cowl	1	
(4) -screw/washer	4/4	
(5) -headlight assembly	1	
(6) Right front cowl	1	
(7) -screw	1	
(8) -right turn signal	1	
(9) Left front cowl	1	
(10) -screw	1	
(11) -left turn signal	1	

Rear Fender B Removal/Installation

Remove the screws and the drive chain cover.

Release the brake hose from the clamps on the rear fender B.

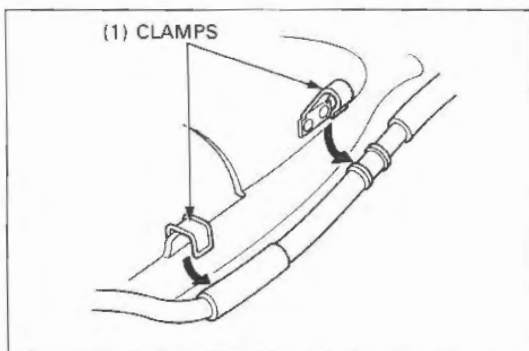

Remove the screws and remove the rear fender B.

Install the removed parts in the reverse order of removal.

NOTE

- After clamping the brake hose with rear clamp on the rear fender B, make sure the clamp opening is less than 7mm (0.28in).

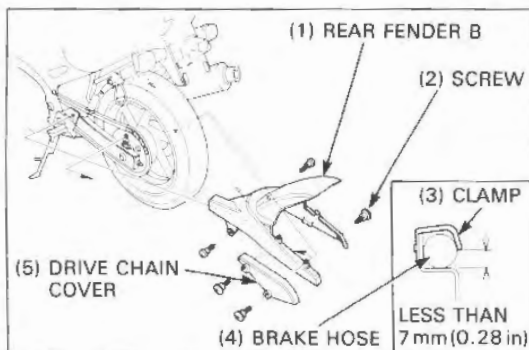

Tail Cowl Removal/Installation

Remove the seat (page 2-2).

Remove the bolts and the tail cowl.

Install the tail cowl in the reverse order of removal.

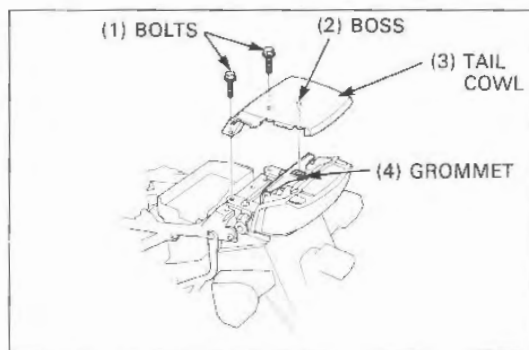

Rear Fender A Removal/Installation.

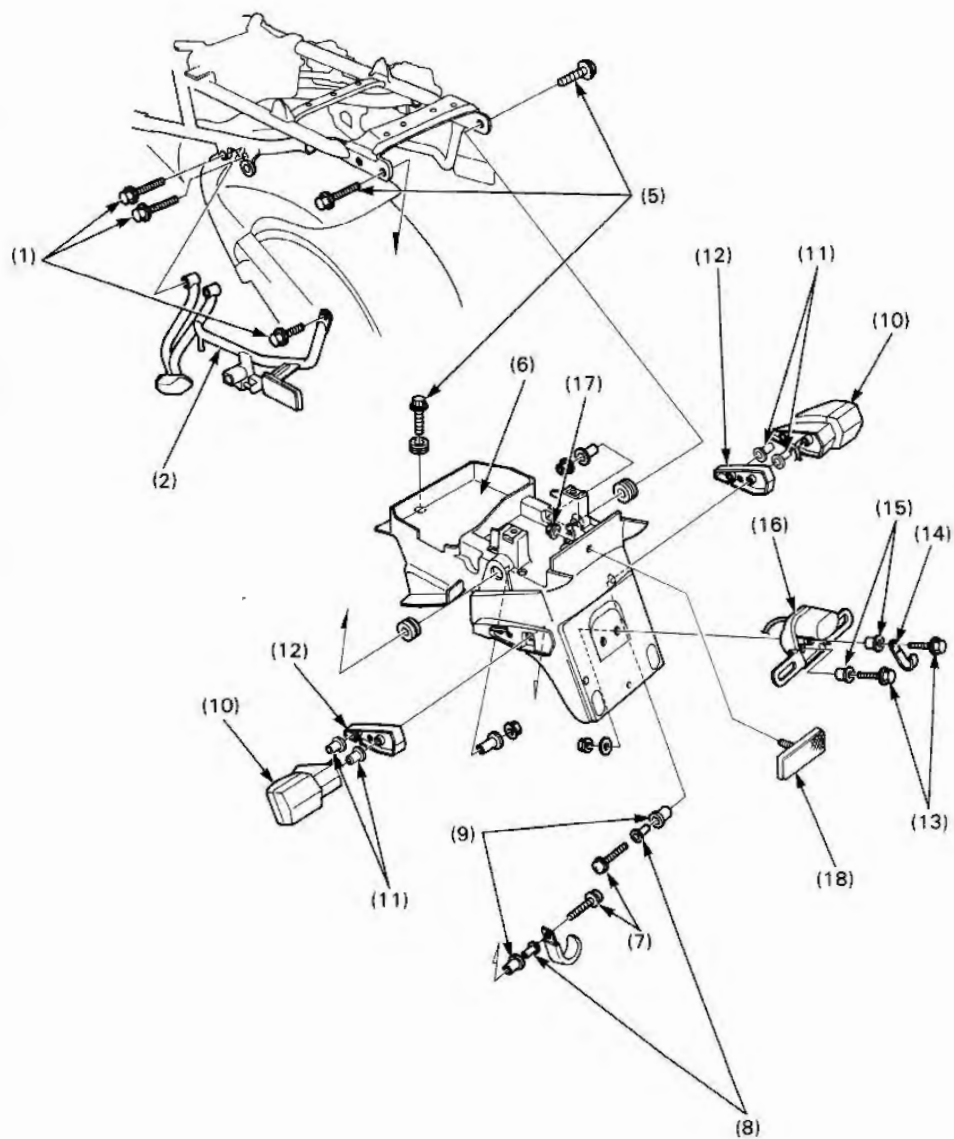

Requisite Service

• Seat removal/installation (page 2-2)

• Tail cowl removal/installation (page 2-7)

Procedure	Q'ty	Remarks
Removal Order		Installation is in the reverse order of removal.
(1) Bolt	3	
(2) Left rear footpeg stay	1	
(3) Turn signal wire connector	2	
(4) License plate light wire connector	1	
(5) Bolt	3	
(6) Rear fender B	1	
(7) -screw	4	
(8) -flange collar	4	
(9) -seat rubber	4	
(10) -rear turn signal (right/left)	1/1	
(11) -flange collar	4	
(12) -turn signal base (right/left)	1/1	
(13) -bolt	2	
(14) -clamp	1	
(15) -flange collar	2	
(16) -license plate light	1	
(17) -nut	1	
(18) -reflector	1	

Exhaust System Removal/Installation

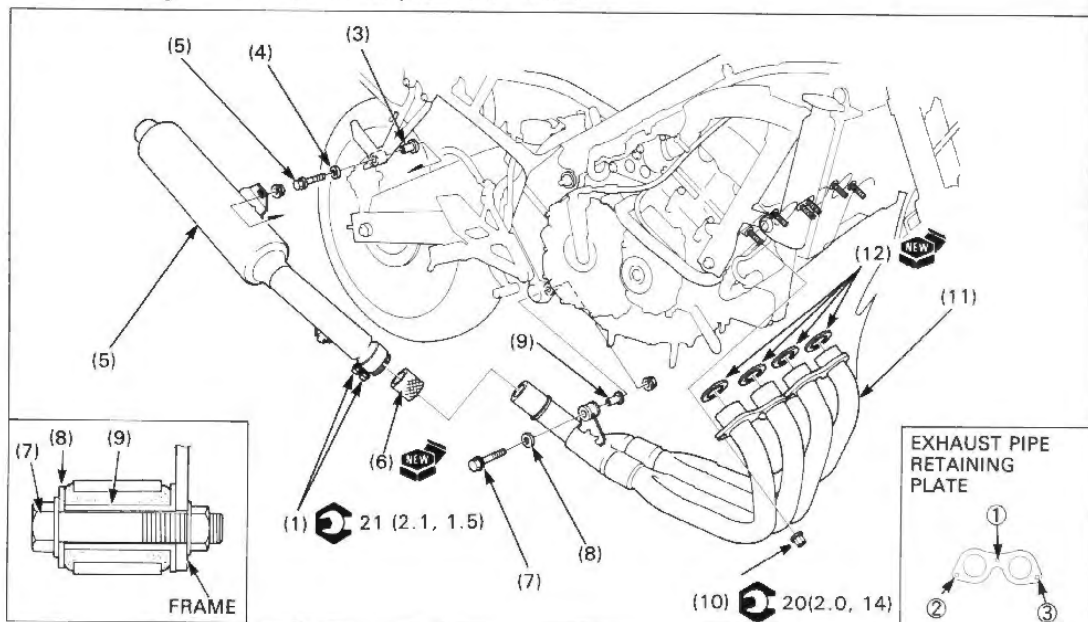

WARNING

- Do not service the exhaust system while it is hot.

Requisite Service

- Side fairing removal/installation (page 2-3)

Procedure	Q'ty	Remarks
Removal Order		
(1) Muffler band bolt	2	Installation is in the reverse order of removal. Only loosen.
(2) Muffler mounting bolt	1	
(3) Flange collar	1	
(4) Washer	1	
(5) Muffler	1	
(6) Muffler gasket	1	
(7) Exhaust pipe mounting bolt	1	
(8) Washer	1	
(9) Flange collar	1	
(10) Exhaust pipe joint nuts	6	NOTE • Install the flange collar with the flange side facing the frame
(11) Exhaust pipe	1	NOTE • Tighten the joint nuts in the order as shown.
(12) Exhaust pipe gasket	4	

Fuel Tank Removal/Installation

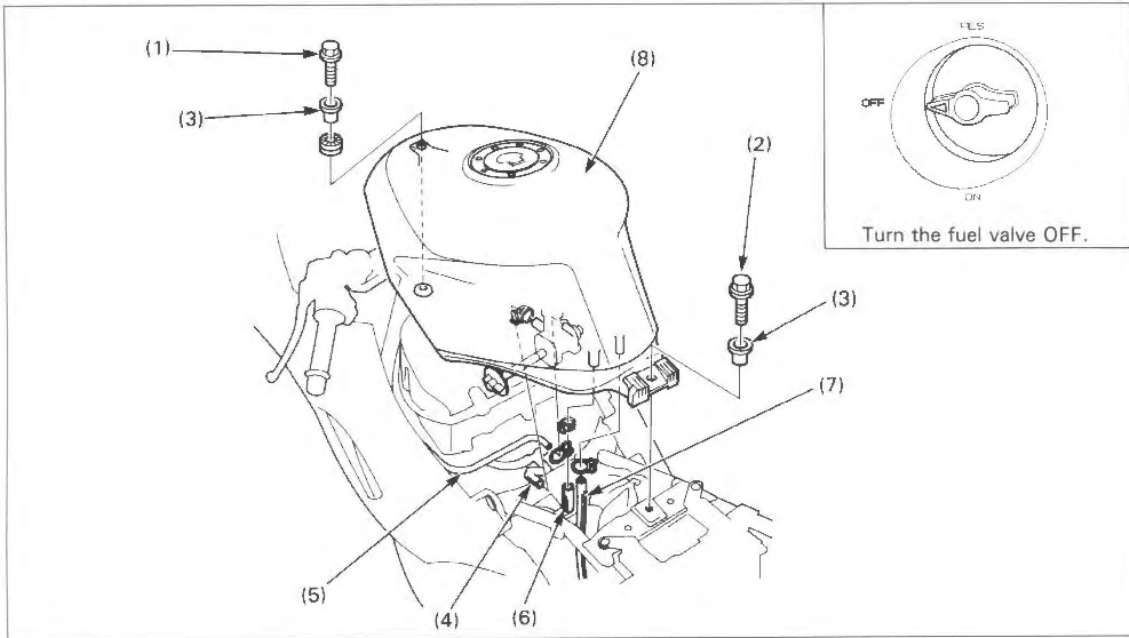

⚠ WARNING

- Gasoline is extremely flammable and is explosive under certain conditions.

Requisite Service

- Seat removal/installation (page 2-2)

Procedure	Q'ty	Remarks
Removal Order		Installation is in the reverse order of removal.
(1) Fuel tank mounting bolt (6mm)	1	Before disconnecting, turn the fuel valve OFF.
(2) Fuel tank mounting bolt (8mm)	1	
(3) Flange collar	2	
(4) Fuel tube	1	
(5) Auto fuel valve vacuum tube	1	
(6) Fuel tank drain tube	1	
(7) Fuel tank vent tube	1	
(8) Fuel tank	1	

3. Maintenance

Service Information	3-1	Spark Plug	3-5
Service Access Guide	3-2	Valve Clearance	3-5
Maintenance Schedule	3-4	Carburetor Synchronization	3-9
Air Cleaner	3-5	Side Stand	3-10

Service Information

- Refer to Common Service Manual for service procedures on items not included in this manual.
- Refer to the specifications (Section 1) for maintenance service data.

Service Access Guide

- The following shows the locations of the parts that must be removed for the maintenance items listed below. Refer to the Common Service Manual for items not included in this manual.
- Refer to section 2 (Frame/Body Panels/Exhaust System) for the parts that must be removed for service.
For example: AIR CLEANER (Contamination, clogging, replacement): Parts
 - Fuel tank — The parts must be removed for service.

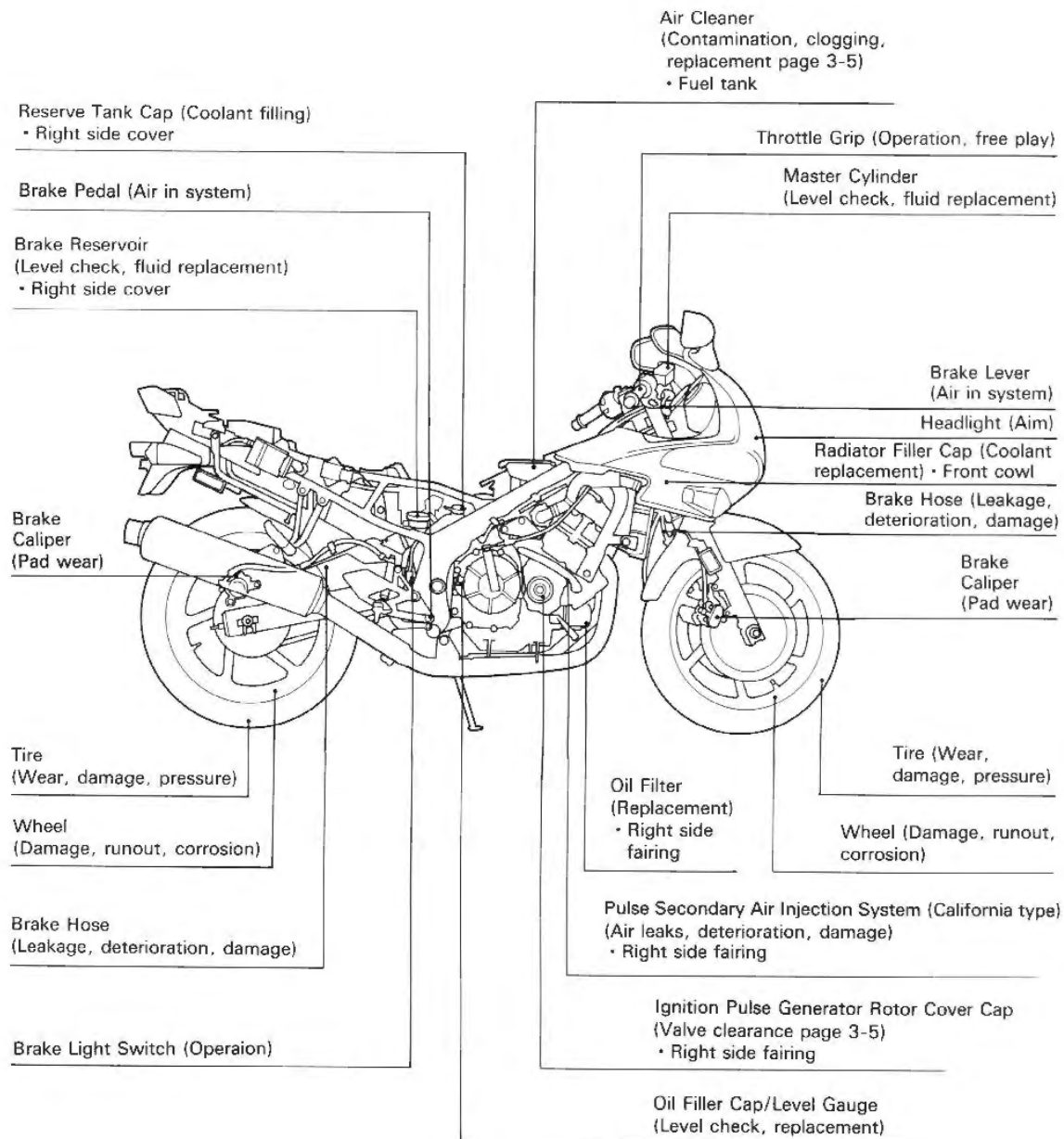

Synchronization Adjusting Screw
(Carburetor synchronization page 3-9)
• Fuel tank

Throttle Stop Screw (Idle speed)
• Left side cover

Carburetor Choke (Operation)

Suspension
(Loose, wear, damage)
• Rear fender B

Clutch Lever (Free play)

Steering Head
Bearings (Damage)

Valve Clearance
(page 3-5)

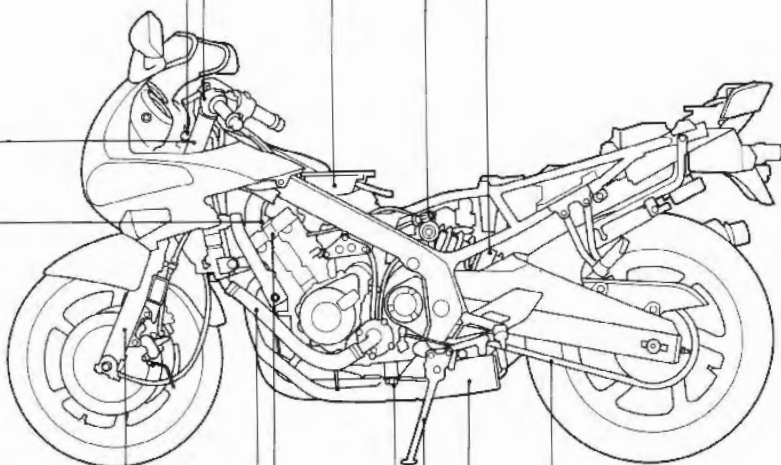

Suspension
(Loose, wear, damage)

Radiator Hose
(Leakage, deterioration, damage)
• Side fairings

Spark Plug (Wear, damage,
coloration)
Maintenance Covers

Engine Oil Drain Bolt
(Oil replacement)
• Left side fairing

Drive Chain
(Free play, lubrication,
replacement)

Evaporative Emission
Canister (California type only)
(Deformation, Hose Connection)
• Side fairings

Side Stand (Operation)

Maintenance Schedule

Perform the PRE-RIDE INSPECTION in the Owner's Manual at each scheduled maintenance period.

I: Inspect and Clean, Adjust, Lubricate, or Replace if necessary.

R: Replace, C: Clean, L: Lubricate, A: Adjust

The following items require some mechanical knowledge. Certain items (particularly those marked * and **) may require more technical information and special tools. Consult your authorized Honda dealer.

Item	Frequency	Note ↓	Odometer Reading (Note 1)								Refer to page
			x 1,000 mi	0.6	4	8	12	16	20	24	
			x 1,000 km	1	6	12	18	24	30	36	
EMISSION RELATED ITEMS	* Fuel Line				I		I		I	Note 5	
	* Throttle Operation				I		I		I	Note 5	
	* Carburetor Choke				I		I		I	Note 5	
	Air Cleaner	(Note 2)					R		R	3-5	
	Spark Plug			I	R	I	R	I	R	3-5	
	* Valve Clearance			I			I			3-5	
	Engine Oil			R		R		R		Note 6	
	Engine Oil Filter			R		R		R		Note 5	
	* Carburetor Synchronization				I		I		I	3-9	
	* Carburetor Idle Speed			I	I	I	I	I	I	Note 6	
	Radiator Coolant	(Note 3)				I		I		R	Note 5
	* Cooling System					I		I		I	Note 5
	* Secondary Air Supply System	(Note 4)				I		I		I	Note 5
	* Evaporative Emission Control System	(Note 4)					I			I	Note 5
NON EMISSION RELATED ITEMS	Drive Chain		Every 600 mi (1,000 km) I, L								Note 5
	Brake Fluid	(Note 3)			I	I	R	I	I	R	Note 5
	Brake Pad Wear				I	I	I	I	I	I	Note 5
	Brake System			I		I		I		I	Note 5
	* Brake Light Switch					I		I		I	Note 5
	* Headlight Aim					I		I		I	Note 5
	Clutch System			I	I	I	I	I	I	I	Note 5
	Side Stand					I		I		I	3-10
	* Suspension					I		I		I	Note 5
	* Nuts, Bolts, Fasteners			I		I		I		I	Note 5
	** Wheels/Tires					I		I		I	Note 5
** Steering Head Bearings			I		I		I		I	Note 5	

* Should be serviced by an authorized Honda dealer, unless the owner has the proper tools and service data and is mechanically qualified.

** In the interest of the safety, we recommend these items be serviced only by an authorized Honda dealer.

Notes: 1. At higher odometer readings, repeat at the frequency interval established here.

2. Service more frequently when riding in unusually wet or dusty areas.

3. Replace every 2 years, or at indicated odometer interval, whichever comes first. Replacement requires mechanical skill.

4. California type only.

5. Refer to Common Service Manual.

6. Use the specification in section one and refer to the Common Service Manual.

Air Cleaner

Remove the fuel tank (page 2-11).

Remove the seven screws, air cleaner housing cover and air cleaner element.

Discard the air cleaner element in accordance with the maintenance schedule.

Also, replace the element any time it is excessively dirty or damaged.

Install the removed parts in the reverse order of removal.

Install the fuel tank (page 2-11).

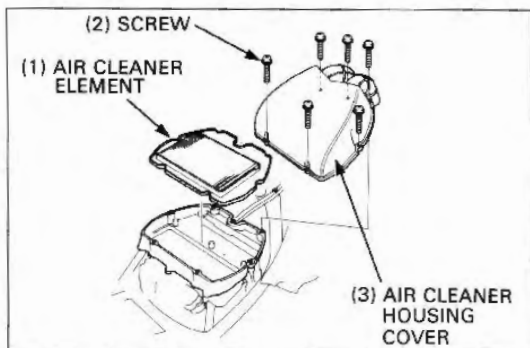

Spark Plug

WARNING

- Do not touch the exhaust system while it is hot.

NOTE

- For detailed instructions, refer to section 2 of the Common Service Manual.
- The No. 1 spark plug can be serviced from the right side, and the No. 2, No. 3 and No. 4 spark plugs can be serviced from the left side.

Remove the maintenance lids by turning the quick screws counterclockwise.

A spark plug wrench is included in the tool kit.

Disconnect the spark plug caps and clean away dirt from around the spark plug bases.

Remove the spark plugs using the wrench in the tool kit.

Install the spark plug in the reverse order of removal. Tighten the spark plug 1/2 turn with the spark plug wrench to compress the sealing washer. If the old plug is retightened, tighten it 1/8-1/4 turn to compress the sealing washer.

Install the maintenance lids and secure them by turning the quick screws clockwise.

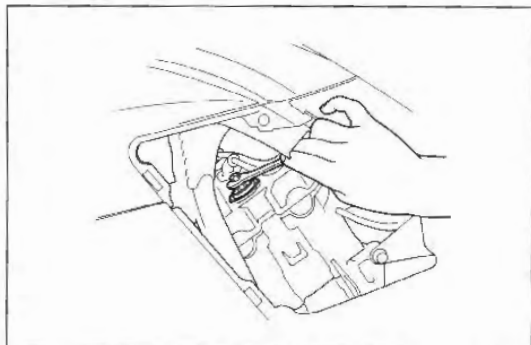
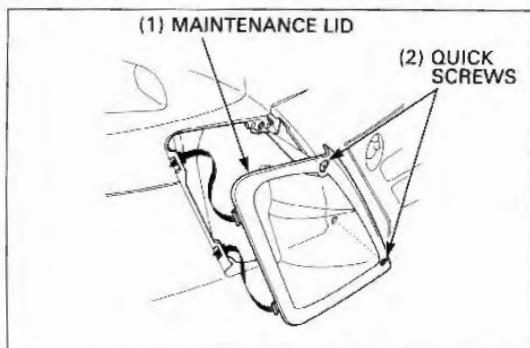

Valve Clearance

Inspection

NOTE

- Adjust the valve clearance while the engine is cold (below 35°C/95°F).

Remove the air cleaner housing base (page 6-3).

Remove the radiator mounting bolts and release the grommet on the radiator top from the boss on the frame.

Move the radiator forward and secure it to the fork tubes with pieces of string as shown.

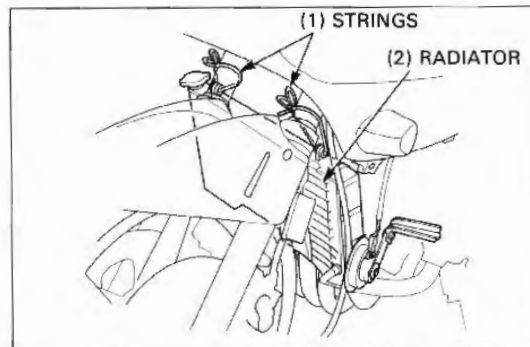

Remove the ignition pulse generator rotor cover cap.

Remove the cylinder head cover (page 8-2).

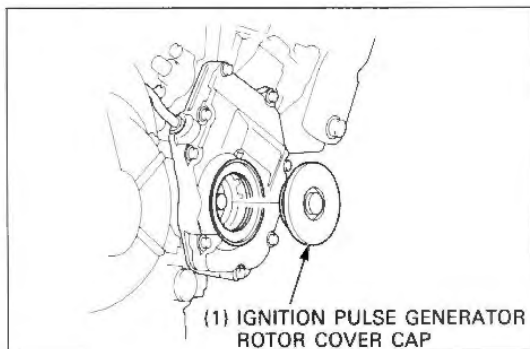

Align the T mark (notch mark) with the index mark on the ignition pulse generator rotor cover by turning the crankshaft clockwise.

Make sure that the timing marks ("IN" and "EX") on the camshaft gears are aligned with the cylinder head upper surface and facing opposite each other as shown.

If the timing marks ("IN" and "EX") on the camshaft gears face each other, turn the crankshaft clockwise one full turn (360°) and realign the T mark (notch mark) with the index mark on the ignition pulse generator rotor cover.

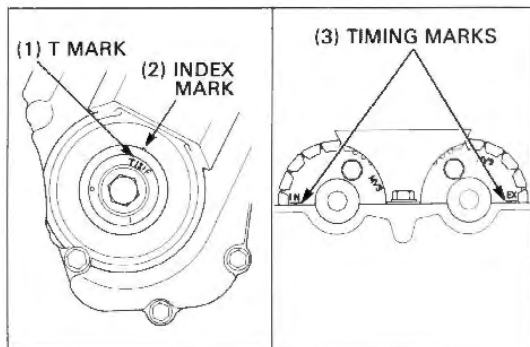

Insert a feeler gauge between the cam lobe and valve lifter at the No. 1 cylinder.

Measure and record the valve clearance.

Valve Clearances :

IN : 0.13-0.19 mm (0.005-0.007 in)

EX : 0.19-0.25 mm (0.007-0.010 in)

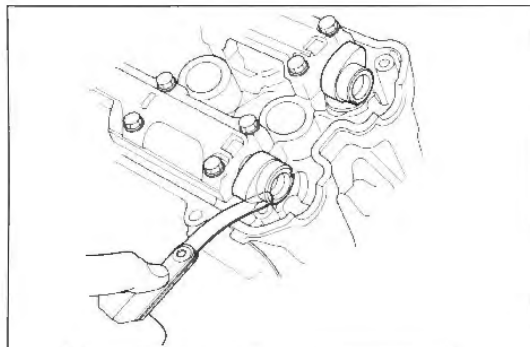

Turn the crankshaft clockwise 1/2 turn (180°) and make sure the index line on the ignition pulse generator rotor is facing up as shown.

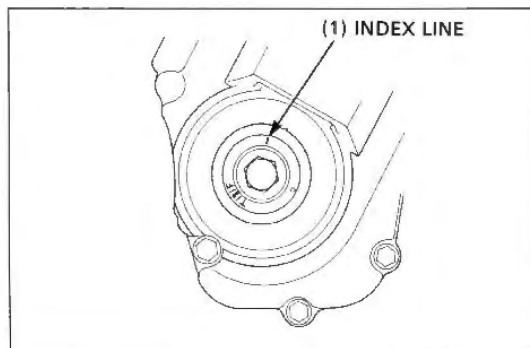

Insert a feeler gauge between the cam lobe and valve lifter for the No. 2 cylinder.

Measure and record the valve clearance.

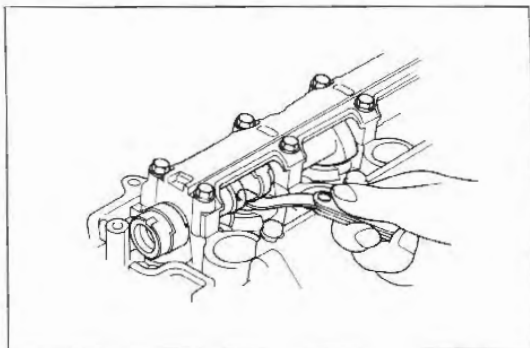

Turn the crankshaft clockwise 1/2 turn (180°) and make sure T mark (notch mark) on the ignition pulse generator rotor aligns with the index mark on the ignition pulse generator cover.

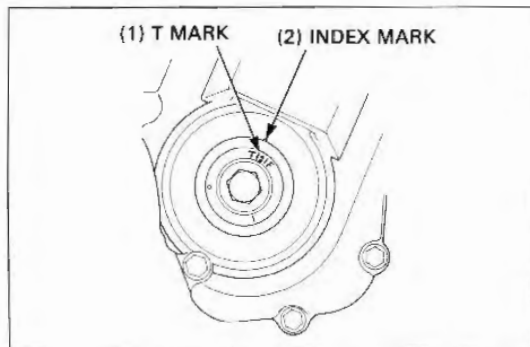

Insert a feeler gauge between the cam lobe and valve lifter for the No. 4 cylinder.

Measure and record the valve clearance.

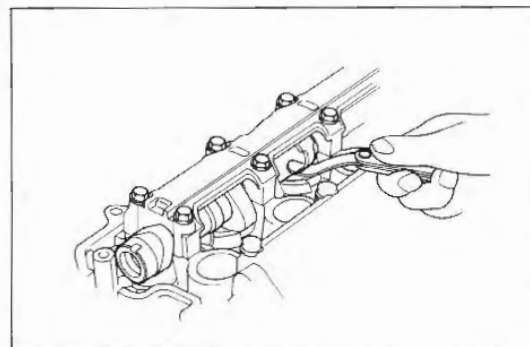

Turn the crankshaft clockwise 1/2 turn (180°) and make sure the index line on the ignition pulse generator rotor is facing up as shown.

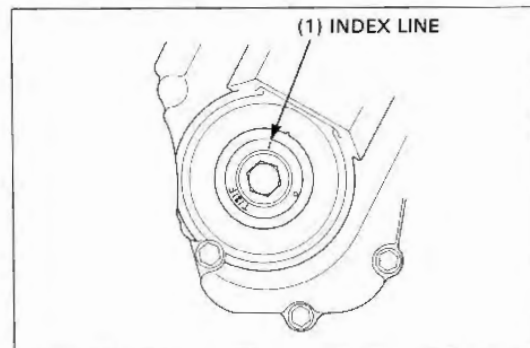

Insert a feeler gauge between the cam lobe and valve lifter for the No. 3 cylinder.

Measure and record the valve clearance.

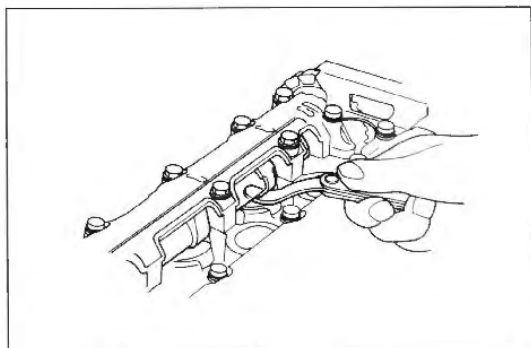

Shim Selection

If the clearance is not correct :

Remove the camshafts (page 8-2).

Remove the valve lifter and shims (page 8-2).

NOTE

- Do not allow shims to fall into the crankcase. The shim(s) may occasionally stick to the valve lifter.
- Mark the positions of all valve lifters and shims to ensure correct reassembly.
- It is easy to remove the valve lifter with a valve lapping tool or magnet.
- Remove the shims with tweezers or a magnet.

Clean the valve lifter with compressed air.

Measure the shim thickness with a micrometer and record it.

NOTE

- Sixty-five different shims are available in thickness intervals of 0.025 mm. The thinnest is 1.200 mm and the thickest is 2.800 mm.

To confirm your shim choice, you may use the following formula :

$$a = (b - c) + d$$

a : new shim thickness

b : recorded valve clearance

c : specified valve clearance

d : old shim thickness

Example:

recorded valve clearance : 0.06 mm

old shim thickness : 1.875 mm

specified valve clearance : 0.16 mm

$$a = (0.06 - 0.16) + 1.875 \text{ mm}$$

$$a = 1.775$$

NOTE

- If the required thickness of the new shim is more than 2.800 mm, the valve seat is probably heavily carboned. Reface the seat, recheck valve clearance and reselect the shim.

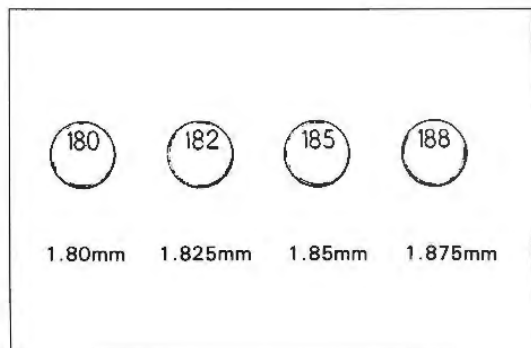
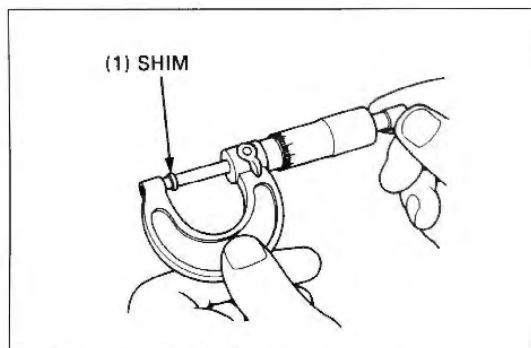
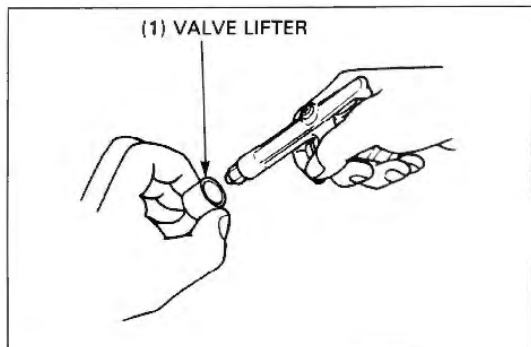

Check the ignition pulse generator rotor cover cap O-ring for damage or deterioration. Replace it with a new one if necessary.

Apply molybdenum disulfide grease to the ignition pulse generator cover cap threads and tighten it.

Torque : 18 N · m (1.8 kg-m, 13 ft-lb)

Install the following :

- cylinder head cover (page 8-2)
- air cleaner housing (page 6-3)
- radiator (page 5-5)

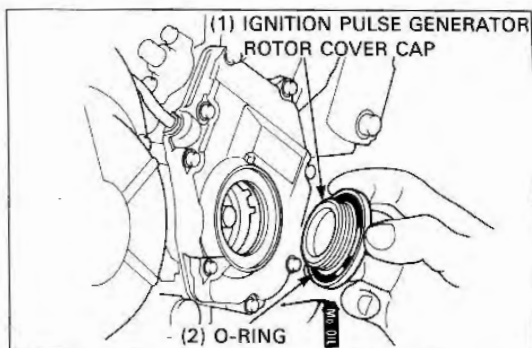

Carburetor Synchronization

NOTE

- Refer to section 2 of the Common Service Manual for carburetor synchronization procedure.
- Synchronize the carburetors with the engine at normal operating temperature and the transmission in neutral.
- No. 2 carburetor is the base carburetor.

Remove the fuel tank (page 2-11).

Disconnect the fuel valve vacuum tube from the No. 1 carburetor vacuum joint.

Remove the rubber cap from the No. 2 carburetor vacuum joint.

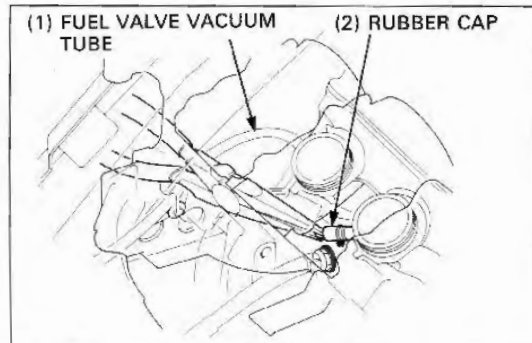

CAUTION

- **Remove the rubber cap by pinching the end of the cap. Do not pinch the cap body or it will be damaged.**

Remove the vacuum plugs from the No.3 and No.4 carburetor.

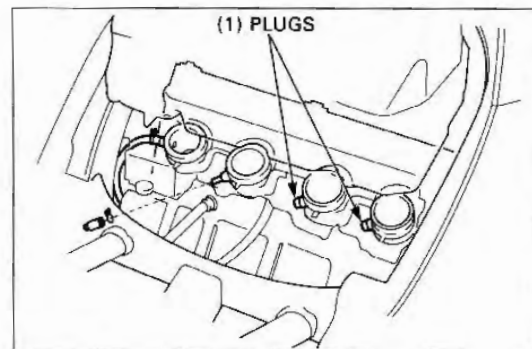

Screw the adaptors in the No.3 and No.4 carburetor vacuum holes.

Connect the vacuum tubes to the carburetor.

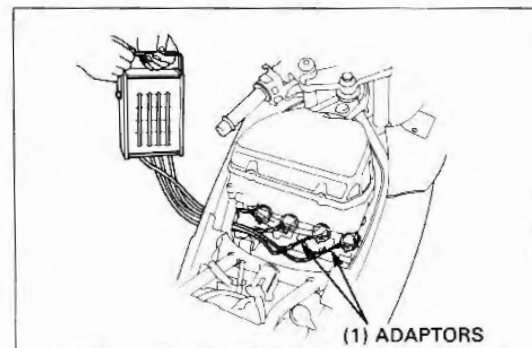

Synchronize the carburetors by turning the adjusting screws.

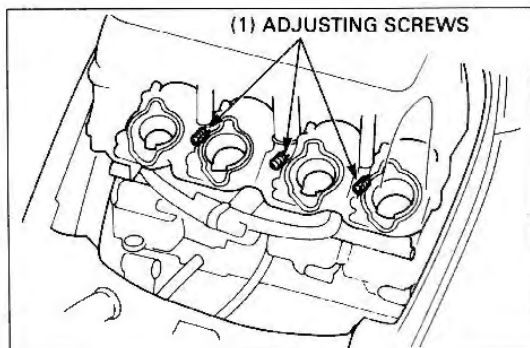

Side Stand

Check the side stand ignition cut-out system:

- Support the motorcycle upright and raise the side stand.
- Start the engine with the transmission in neutral, then shift the transmission into gear with the clutch lever pulled in.
- Move the side stand down fully.
- The engine should stop as the side stand is lowered.

If there is a problem with the system, check the side stand switch (Section 18).

Check the side stand switch mounting bolts for looseness.

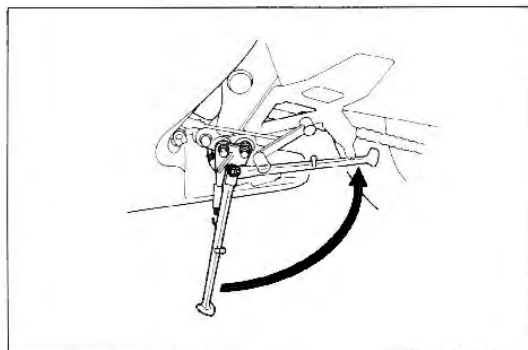

4. Lubrication System

Service Information	4-1	Oil Pump Removal/Installation	4-4
Troubleshooting	4-1	Oil Pump Disassembly/Assembly	4-5
Lubrication System Diagram	4-2	Oil Cooler Removal/Installation	4-6
Oil Pan Removal/Installation	4-3	Oil Cooler Disassembly/Assembly	4-7

Service Information

▲ WARNING

- If the engine must be running to do some work, make sure the area is well-ventilated. Never run the engine in an enclosed area. The exhaust contains poisonous carbon monoxide gas that can cause loss of consciousness and may lead to death.
- Used engine oil may cause skin cancer if repeatedly left in contact with the skin for prolonged periods. Although this is unlikely unless you handle used oil on a daily basis, it is still advisable to thoroughly wash your hands with soap and water as soon as possible after handling used oil. **KEEP OUT OF REACH OF CHILDREN.**

- The service procedures in this section can be performed with the engine in the frame.
- When removing and installing the oil pump, use care not to allow dust or dirt to enter the engine.
- If any portion of the oil pump is worn beyond the specified service limits, replace the oil pump as an assembly.
- After the oil pump has been installed, check that there are no oil leaks and that oil pressure is correct.
- Always lubricate the oil pump components with clean engine oil when assembling the oil pump.

Troubleshooting

Oil Level Low

- Oil consumption
- External Oil Leak
- Worn piston ring or incorrect piston ring installation
- Worn valve guide or seal
- Oil pump worn or damaged
- Oil leaks in the cooling system

Low Or No Oil Pressure

- Clogged oil orifice
- Clogged oil passage
- Incorrect oil being used

No Oil Pressure

- Oil level too low
- Oil pump drive chain or drive sprocket broken
- Oil pump damaged (pump shaft)
- Internal oil leaks

Low Oil Pressure

- Pressure relief valve stuck open
- Clogged oil filter
- Oil pump worn or damaged
- Internal oil leaks
- Incorrect oil being used
- Oil level too low

High Oil Pressure

- Pressure relief valve stuck closed and oil filter plugged
- Plugged oil filter, gallery, or metering orifice
- Incorrect oil being used

Lubrication System Diagram

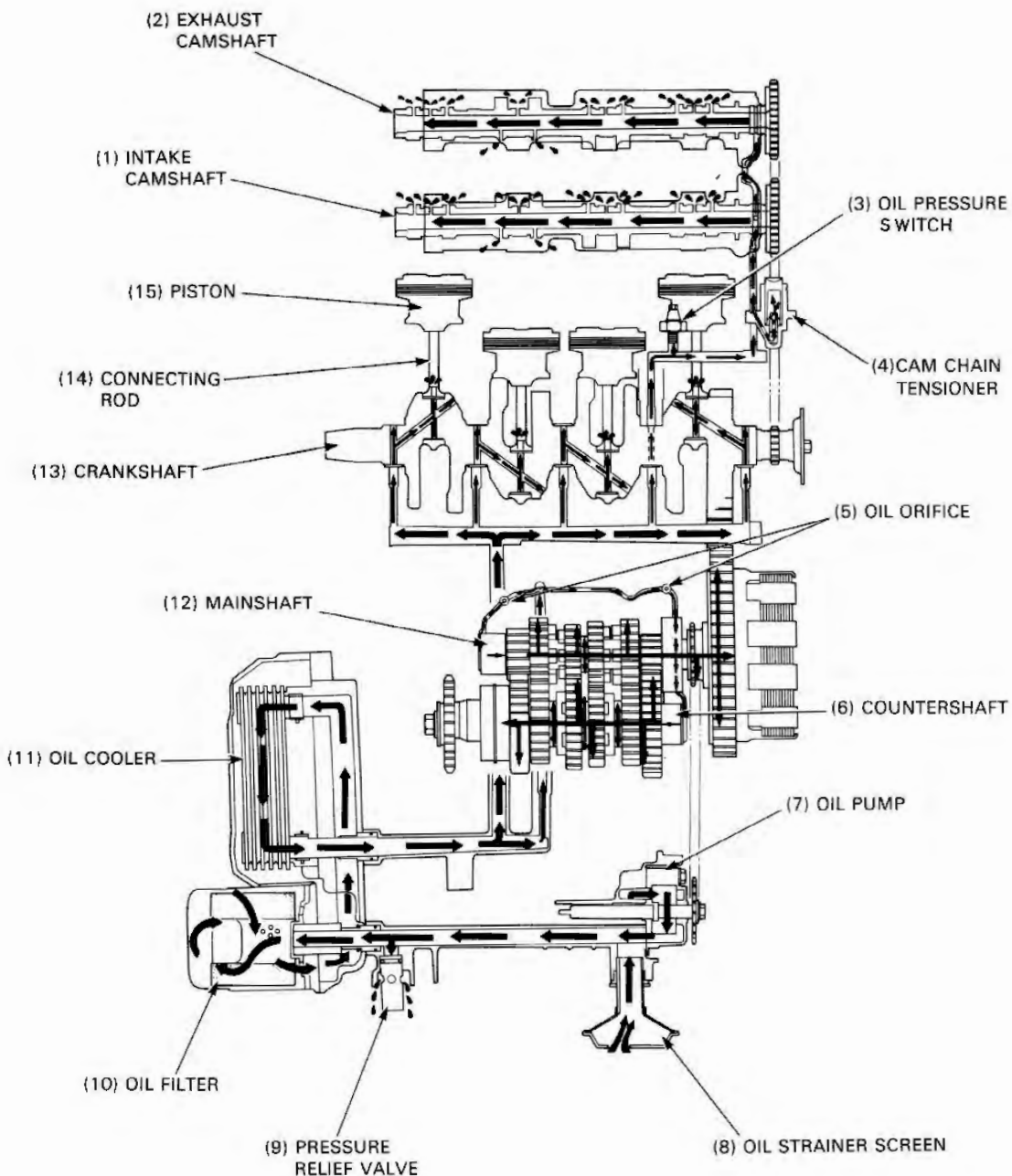

Oil Pan Removal/Installation

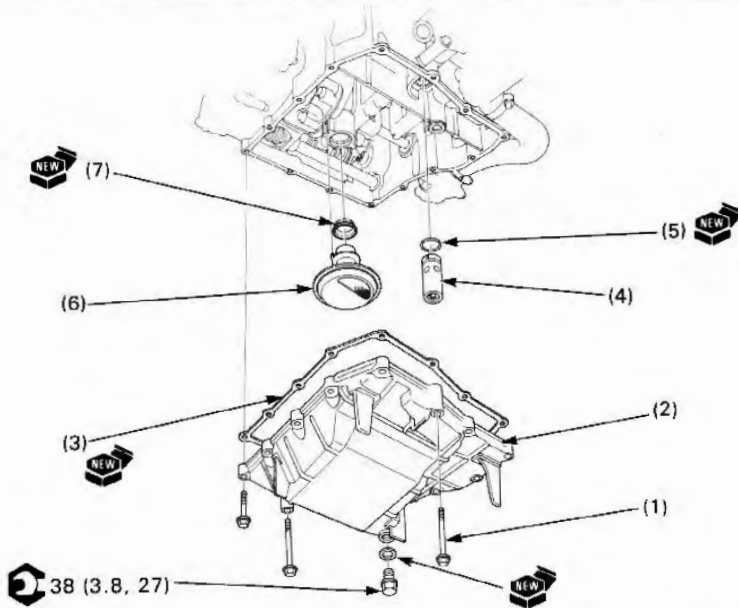

Requisite Service

- Exhaust pipe removal/installation (page 2-10)

Procedure	Q'ty	Remarks
Removal Order		
(1) Oil pan bolt	14	Installation is in the reverse order of removal.
(2) Oil pan	1	Tighten the bolts in a gradual, crisscross pattern.
(3) Gasket	1	Clean the liquid sealant residue off the mating surfaces.
(4) Pressure relief valve	1	
(5) O-ring	1	
(6) Oil strainer	1	
(7) Oil strainer gasket	1	Install the oil strainer gasket in the lower crankcase with its flange side facing oil strainer.

Oil Pump Removal/Installation

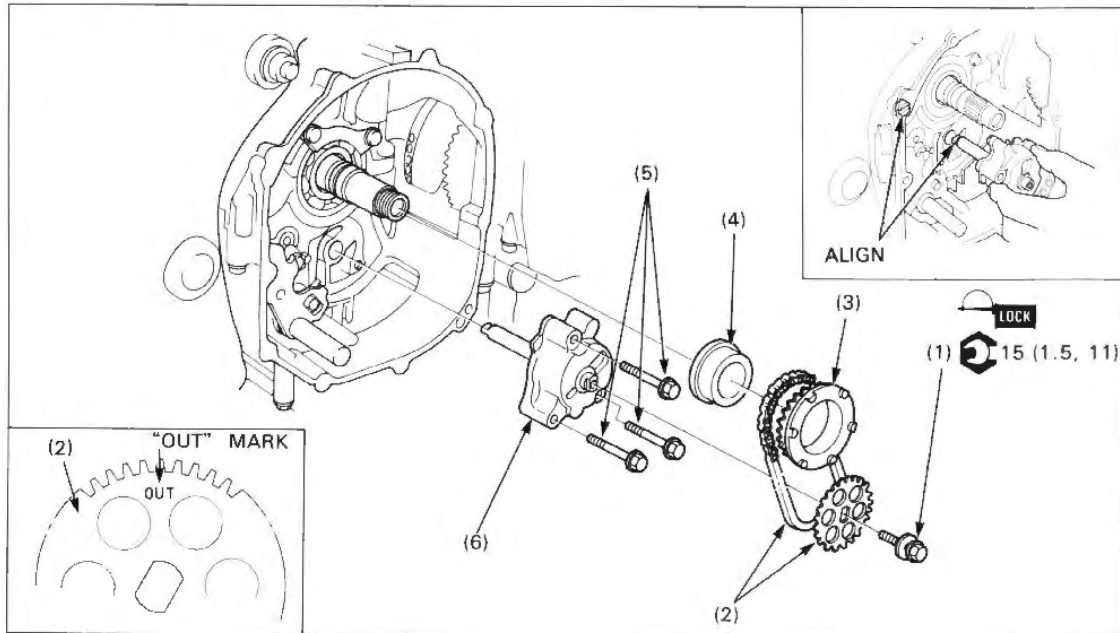

NOTE

- Use care not to allow dust or dirt to enter the engine.
- After installation, check that there are no oil leaks and that oil pressure is correct.

Requisite Service

- Clutch removal (page 9-4)
- Clutch installation (page 9-12)

Procedure		Q'ty	Remarks
Removal Order			
(1)	Oil pump driven sprocket bolt	1	Installation is in the reverse order of removal.
(2)	Oil pump driven sprocket/Oil pump drive chain	1/1	
(3)	Oil pump drive sprocket	1	Install the oil pump driven sprocket with the "OUT" mark facing out.
(4)	Oil pump drive sprocket collar	1	
(5)	Oil pump mounting bolt	3	
(6)	Oil pump assembly	1	

Oil Pump Disassembly/Assembly

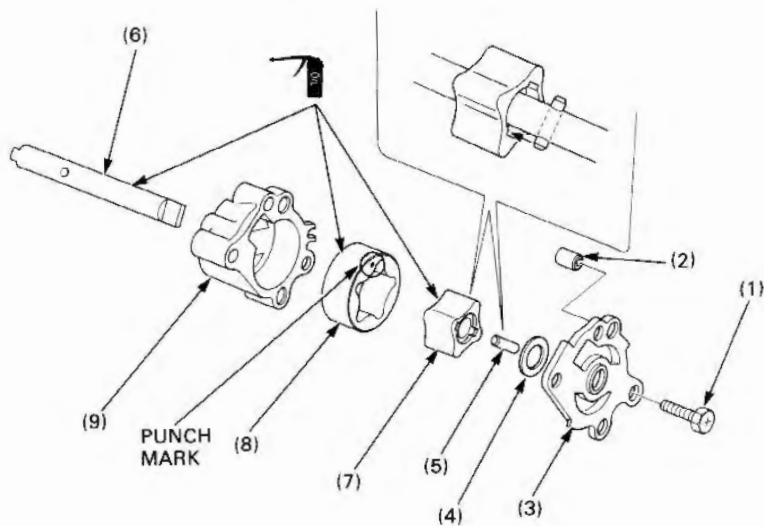

NOTE

- If any portion of the oil pump is beyond the specified service limits, replace the oil pump as an assembly.
- Before assembling, clean all the parts thoroughly with clean engine oil.
- Refer to section 4 of the Common Service Manual for inspection information.

Requisite Service

- Oil pump removal/installation (page 4-4)

Procedure	Q'ty	Remarks
Disassembly Order		Assembly is in the reverse order of disassembly.
(1) Oil pump cover bolt.	1	
(2) Dowel pin	1	
(3) Oil pump cover	1	
(4) Thrust washer	1	
(5) Drive pin	1	Install the drive pin into the hole in the pump shaft and align the pin with the groove in the inner rotor.
(6) Oil pump shaft	1	
(7) Inner rotor	1	
(8) Outer rotor	1	Install the outer rotor with the punch mark facing the oil pump cover.
(9) Oil pump body	1	

Oil Cooler Removal/Installation

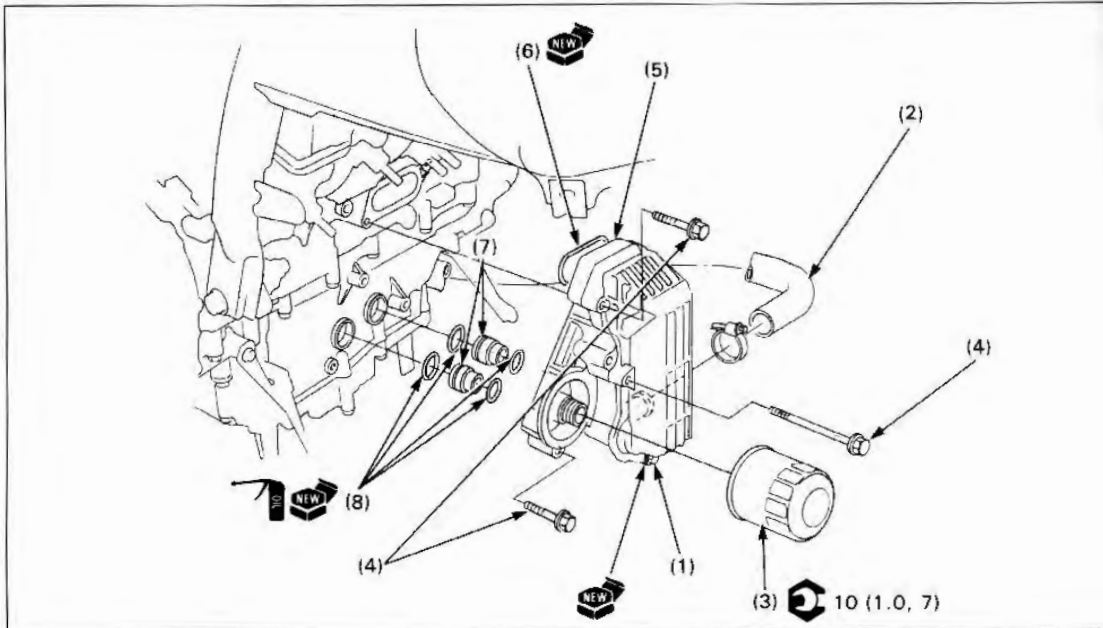

Requisite Service

- Side fairing removal/installation (page 2-3)
- Engine oil draining/filling
- Coolant draining/filling (page 5-3)

Procedure		Q'ty	Remarks
Removal Order			Installation is in the reverse order of removal.
(1)	Drain bolt/Sealing washer	1/1	
(2)	Water hose	1	
(3)	Oil filter element	1	
(4)	Oil cooler mounting bolt	4	
(5)	Oil cooler assembly	1	
(6)	O-ring	1	
(7)	Joint collar	2	
(8)	O-ring	4	

Oil Cooler Disassembly/Assembly

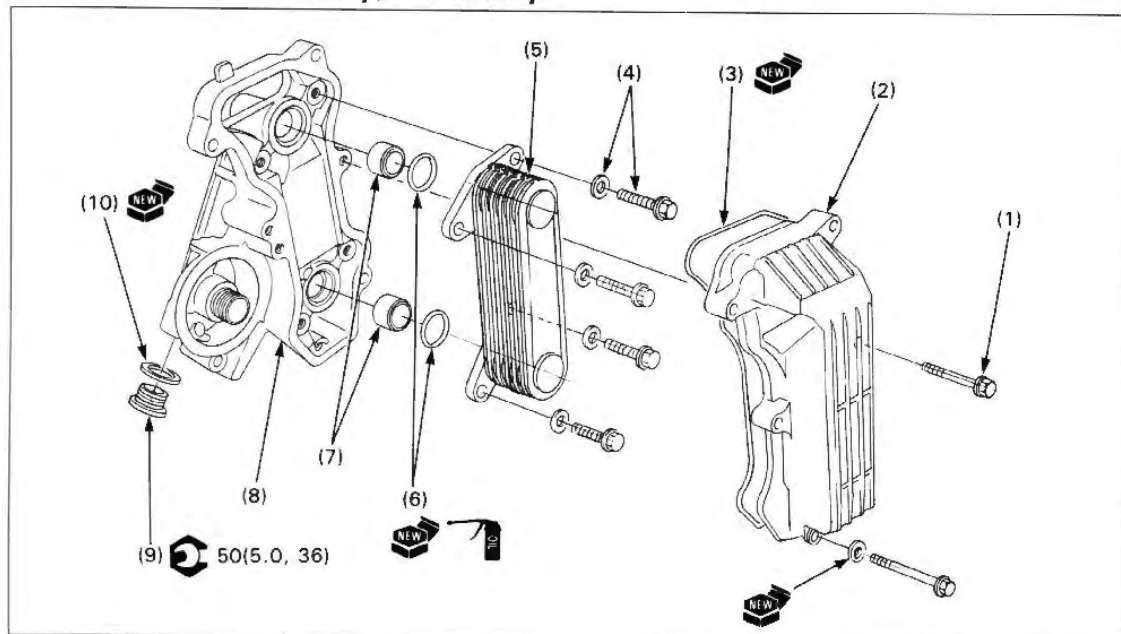

Requisite Service

- Oil cooler removal/installation (page 4-6)

Procedure	Q'ty	Remarks
Disassembly Order		Assembly is in the reverse order of disassembly.
(1) Oil cooler case bolt	1	NOTE • Once the oil cooler case O-ring is removed, always replace it with a new one and install it securely into the groove in the oil cooler case. Do not remove the special bolt unless necessary.
(2) Oil cooler case	1	
(3) O-ring	1	
(4) Bolt/Washer	4/4	
(5) Oil cooler	1	
(6) O-ring	2	
(7) Joint collar	2	
(8) Oil cooler base	1	
(9) Special bolt	1	
(10) Sealing washer	1	

5. Cooling System

Service Information	5-1	Radiator Removal/Installation	5-5
Troubleshooting	5-1	Radiator Disassembly/Assembly	5-6
System Flow Pattern	5-2	Water Pump Disassembly/Assembly	5-7
Coolant Draining	5-3	Reserve Tank Removal/Installation	5-8
Thermostat Removal/Installation	5-4		

Service Information

▲ WARNING

- Wait until the engine is cool before slowly removing the radiator cap. Removing the cap while the engine is hot and the coolant is under pressure may cause serious scalding.
- Radiator coolant is toxic. Keep it away from eyes, mouth, skin and clothes.
 - If any coolant gets in your eyes, rinse them with water and consult a doctor immediately.
 - If any coolant allowed, induce vomiting, gargle and consult a physician immediately.
 - If any coolant gets in your skin or clothes, rinse thoroughly with plenty of water.
- KEEP OUT OF REACH OF CHILDREN.

- Add coolant at the reserve tank. Do not remove the radiator cap except to refill or drain the system.
- All cooling system service can be done with the engine in the frame.
- For fan motor switch and thermo sensor inspections, refer to section 25 of the Common Service Manual . For the switch and sensor locations, see page 18-2 of this manual.

Troubleshooting

Engine Temperature Too High

- Faulty temperature gauge or thermo sensor
- Thermostat stuck closed
- Faulty radiator cap
- Insufficient coolant
- Passages blocked in radiator, hoses or water jacket
- Air in system
- Faulty cooling fan motor
- Faulty fan motor switch
- Faulty water pump

Engine Temperature Too Low

- Faulty temperature gauge or thermo sensor
- Thermostat stuck open
- Faulty fan motor switch

Coolant Leaks

- Faulty oil pump mechanical seal
- Deteriorated O-ring
- Faulty radiator cap
- Damaged cylinder gasket
- Loose hose connection or clamp
- Damaged or deteriorated hoses

System Flow Pattern

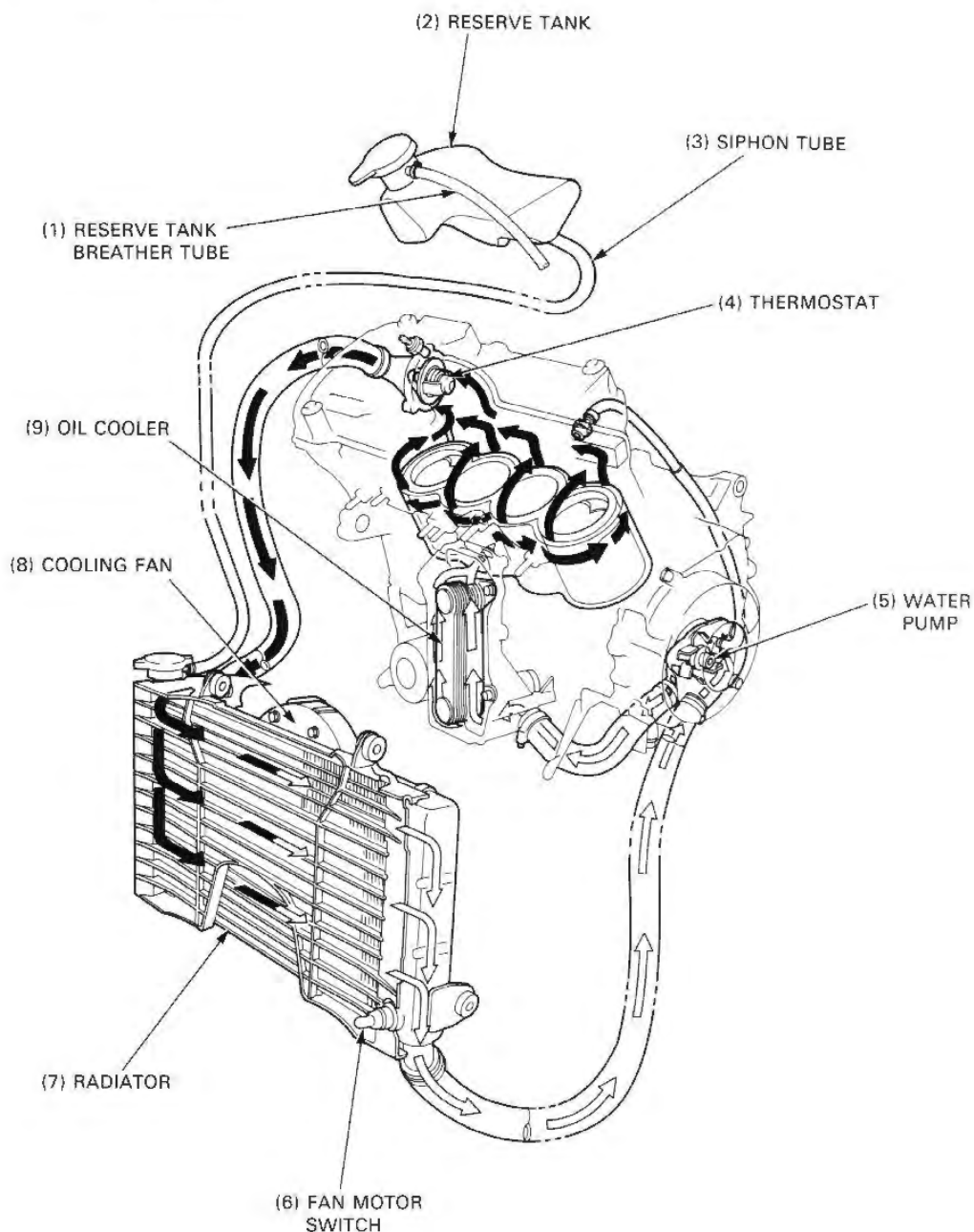

Coolant Draining

▲ WARNING

- Wait until the engine is cool before servicing the cooling system. Removing the radiator cap while the engine is hot and the coolant is under pressure may serious scalding.

NOTE

- For coolant replacement, refer to section 5 of the Common Service Manual.

Remove the left side fairing (page 2-3).

Remove the water pump drain bolt and sealing washer.

Remove the radiator cap and drain the coolant.

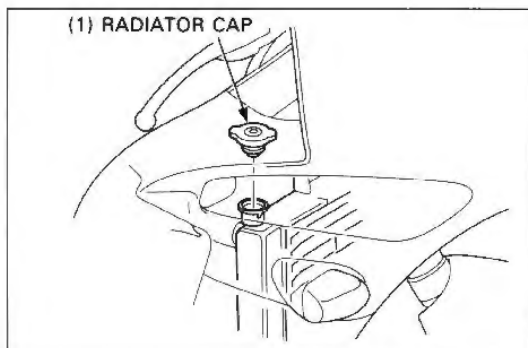
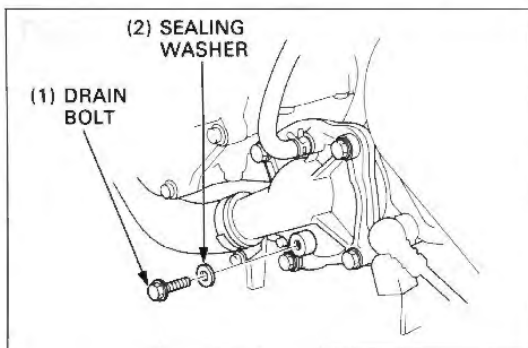

Place a suitable tray under the siphon tube joint of the reserve tank and disconnect the siphon tube from the reserve tank.

Drain the coolant from the reserve tank.

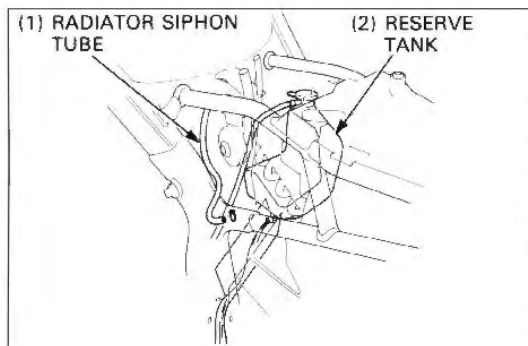

Install the water pump drain bolt with a new sealing washer, and connect the siphon tube to the reserve tank.

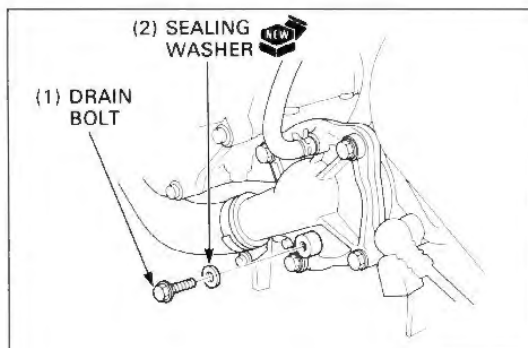

Thermostat Removal/Installation

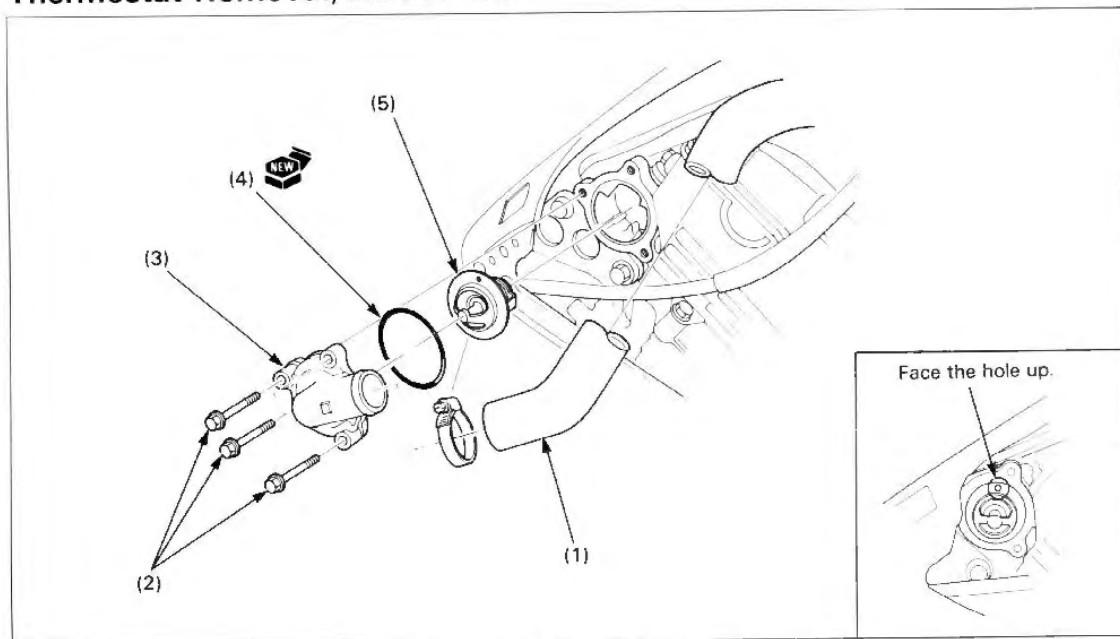

Requisite Service

- Coolant draining (page 5-3)
- Right maintenance cover removal/installation (page 2-3)
- Coolant refill (section 5 of the Common Service Manual)

Procedure	Q'ty	Remarks
Removal order (1) Water hose (2) Thermostat housing cover bolt (3) Thermostat housing cover (4) O-ring (5) Thermostat	1 3 1 1 1	Installation is in the reverse order of removal. NOTE <ul style="list-style-type: none"> • Install the thermostat with the motorcycle on the side stand. • Install the thermostat with its hole facing up and fit it properly in the housing.

Radiator Removal/Installation

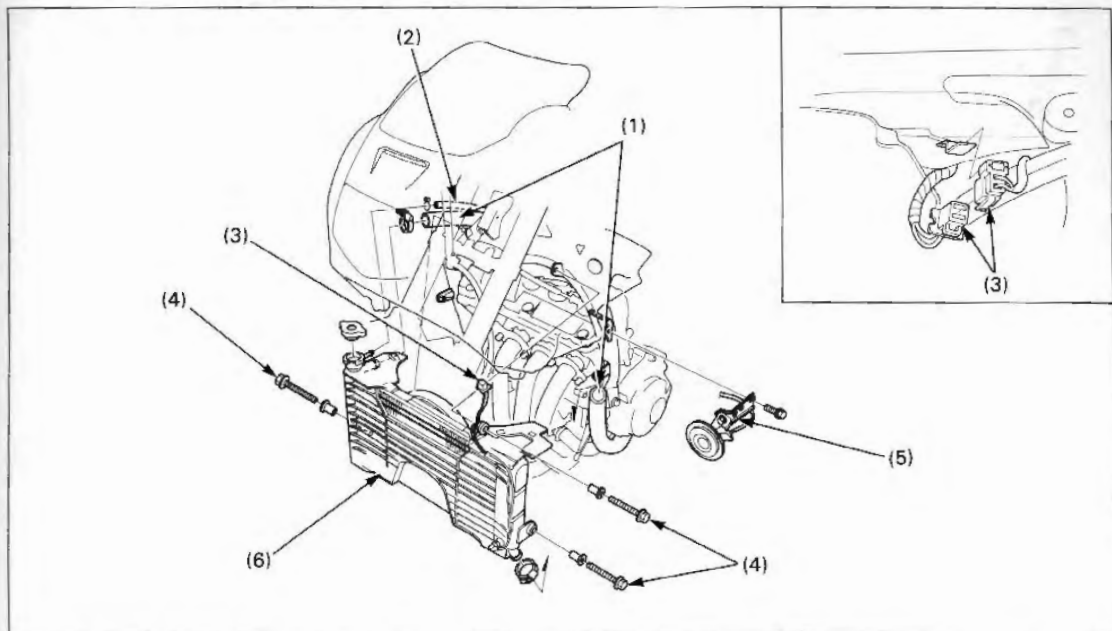

Requisite Service

- Side fairing removal/installation (page 2-3)
- Air cleaner housing removal/installation (page 6-3)
- Coolant draining (page 5-3)
- Coolant refill (section 5 of the Common Service Manual)

Procedure	Q'ty	Remarks
Removal Order (1) Radiator hose (2) Radiator siphon tube (3) Fan motor connector (4) Radiator mounting bolt (5) Horn stay (6) Radiator assembly	2 1 1 3 1 1	Installation is in the reverse order of removal. CAUTION • During removal and installation, be careful not to damage the radiator fins. When installing, align the grommet on the top of the radiator with the boss on the frame.

Radiator Disassembly/Assembly

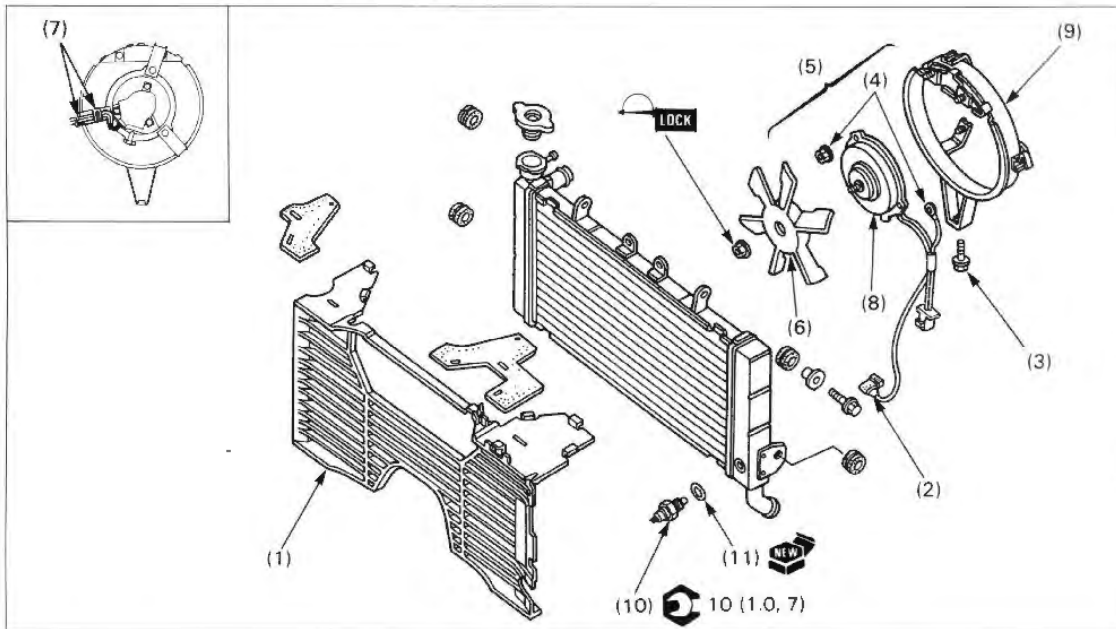

Requisite Service

- Radiator removal/installation (page 5-5)

Procedure	Q'ty	Remarks
(1) Disassembly Order Radiator grill	1	Assembly is in the reverse order of disassembly. Remove the radiator grill by releasing the four tangs on the radiator from the slot in the grill. When installing, align the fan groove with the motor shaft. Release the fan motor wire. CAUTION • Do not overtighten the fan motor switch, or the radiator may be damaged.
(2) Fan motor switch connector	1	
(3) Fan motor mounting bolt	1	
(4) Fan motor mounting nut/terminal	2/1	
(5) Fan motor assembly	1	
(6) Cooling fan	1	
(7) Clamp	2	
(8) Fan motor	1	
(9) Fan motor shroud	1	
(10) Fan motor switch	1	
(11) O-ring	1	

Water Pump Disassembly/Assembly

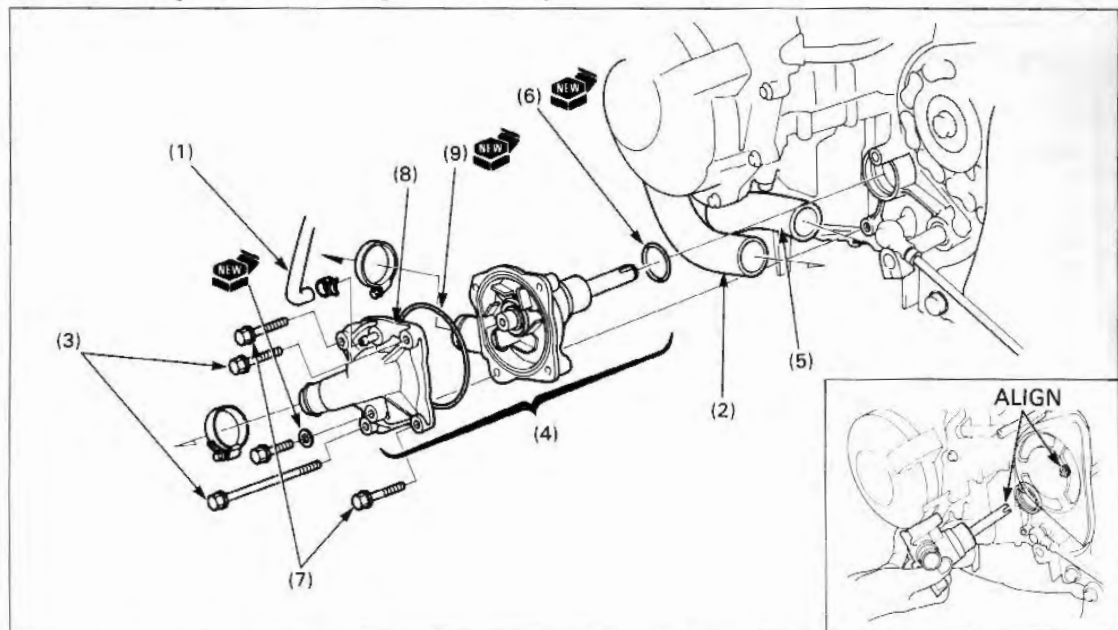

Requisite Service

- Side fairing removal/installation (page 2-3)
- Coolant draining (page 5-3)
- Coolant refill (section 5 of the Common Service Manual)

Procedure	Q'ty	Remarks
Disassembly Order		Assembly is in the reverse order of disassembly.
(1) Water hose (to cylinder head)	1	
(2) Water hose (to radiator)	1	
(3) Water pump mounting bolt	2	NOTE
(4) Water pump assembly	1	• If you plan to disassemble the water pump, loosen the water pump cover bolts before loosening the mounting bolts.
(5) Water hose (to oil cooler)	1	When installing, align the cut-out of the water pump shaft with the end of the oil pump shaft.
(6) O-ring	1	
(7) Water pump cover bolt	2	
(8) Water pump cover	1	
(9) O-ring	1	

Reserve Tank Removal/Installation

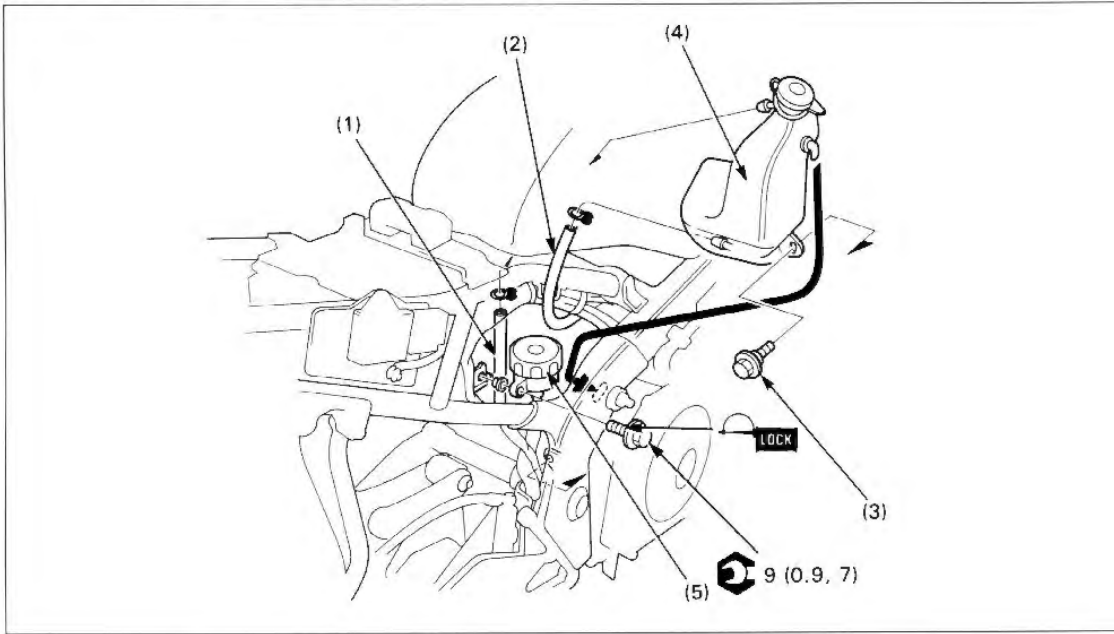

Requisite Service

- Coolant draining (page 5-3)
- Shock absorber removal/installation (page 13-4)
- Right side cover removal/installation (page 2-2)
- Coolant refill (section 5 of the Common Service Manual)

Procedure	Q'ty	Remarks
Removal Order		Installation is in the reverse order of removal.
(1) Siphon tube	1	
(2) Reserve tank breather tube	1	
(3) Reserve tank mounting bolt	1	
(4) Rear master cylinder reservoir	1	
(5) Reserve tank	1	
		NOTE
		• Release the hook on the reserve tank from the oval hole in the frame by pivoting the tank rearward.

6. Fuel System

Service Information	6-1	Pulse Secondary Air Injection (PAIR)	6-12
Troubleshooting	6-2	Control Valve Removal/Installation (California Type Only)	
Air Cleaner Housing Removal/Installation	6-3	Evaporative Emission (EVAP) Canister, Removal/Installation (California Type Only)	6-13
Carburetor Removal/Installation	6-4	Pilot Screw Adjustment	6-14
Carburetor Separation	6-6	High Altitude Adjustment (U.S.A. Only)	6-15
Carburetor Disassembly/Assembly	6-8		
Carburetor Combination	6-10		

Service Information

▲ WARNING

- Gasoline is extremely flammable and is explosive under certain conditions. KEEP OUT OF REACH OF CHILDREN.
- Bending or twisting the control cables will impair smooth operation and could cause the cables to stick or bind, resulting in loss of vehicle control.
- Work in a well ventilated area. Smoking or allowing flames in the work or where gasoline is stored can cause a fire or explosion.

CAUTION

- Be sure to remove the diaphragms before cleaning air and fuel passages with compressed air. The diaphragms might be damaged.
- Refer to section 2 for fuel tank removal and installation.
- When disassembling the fuel system components, note the locations of the O-rings. Replace them with new ones on reassembly.
- Before disassembling the carburetor, place an approved fuel container under the carburetor drain bolt, loosen the bolt and drain the carburetor.
- After removing the carburetor, wrap the intake port of the engine with a shop towel or cover it with a piece of tape to prevent any foreign material from dropping into the engine.

NOTE

- If the vehicle is to be stored for more than one month, drain the float bowls. Fuel left in the float bowls may cause clogged jets resulting in hard starting or poor driveability.

Troubleshooting

Engine Won't Start

- Too much fuel getting to the engine
 - Air cleaner element clogged
 - Flooded carburetors
- Intake air leak
- Fuel contaminated/deteriorated
- Slow circuit of starting enrichment circuit clogged
- No fuel to carburetors
 - Fuel strainer clogged
 - Fuel tube clogged
 - Float valve stuck
 - Float level misadjusted
 - Fuel tank breather tube clogged
- Emission control system malfunction (California type only)
 - EVAP CAV control valve faulty
 - Evaporative emission purge control valve faulty
 - Loose, disconnected or deteriorated hoses of the emission control system

Lean Mixture

- Fuel jets clogged
- Float valve faulty
- Float level too low
- Fuel line restricted
- Carburetor air vent hole (or tube) clogged
- Intake air leak
- Throttle valve faulty
- Vacuum piston faulty
- EVAP CAV control valve faulty (California type only)

Rich Mixture

- Starting enrichment valve in ON position
- Float valve faulty
- Float level too high
- Air jets clogged
- Air cleaner element contaminated
- Flooded carburetors

Engine Stalls, Hard To Start, Rough Idling

- Fuel line restricted
- Ignition malfunction
- Fuel mixture too lean/rich
- Fuel contaminated/deteriorated
- Intake air leak
- Idle speed misadjusted
- Float level misadjusted
- Fuel tank breather tube clogged
- Pilot screw misadjusted
- Slow circuit or starting enrichment circuit clogged

Afterfiring When Engine Braking Is Used

- Lean mixture in slow circuit.
- Emission control system malfunction (California type only)
 - Pulse secondary air injection system faulty
 - Loose, disconnected or deteriorated hoses of the emission control system

Backfiring Or Misfiring During Acceleration

- Ignition system faulty
- Fuel mixture too lean

Poor Performance (Driveability) And Poor Fuel Economy

- Fuel system clogged
- Ignition malfunction
- Emission control system malfunction (California type only)
 - Pulse secondary air injection system faulty
 - Loose, disconnected or deteriorated hoses of the emission control system

Air Cleaner Housing Removal/Installation

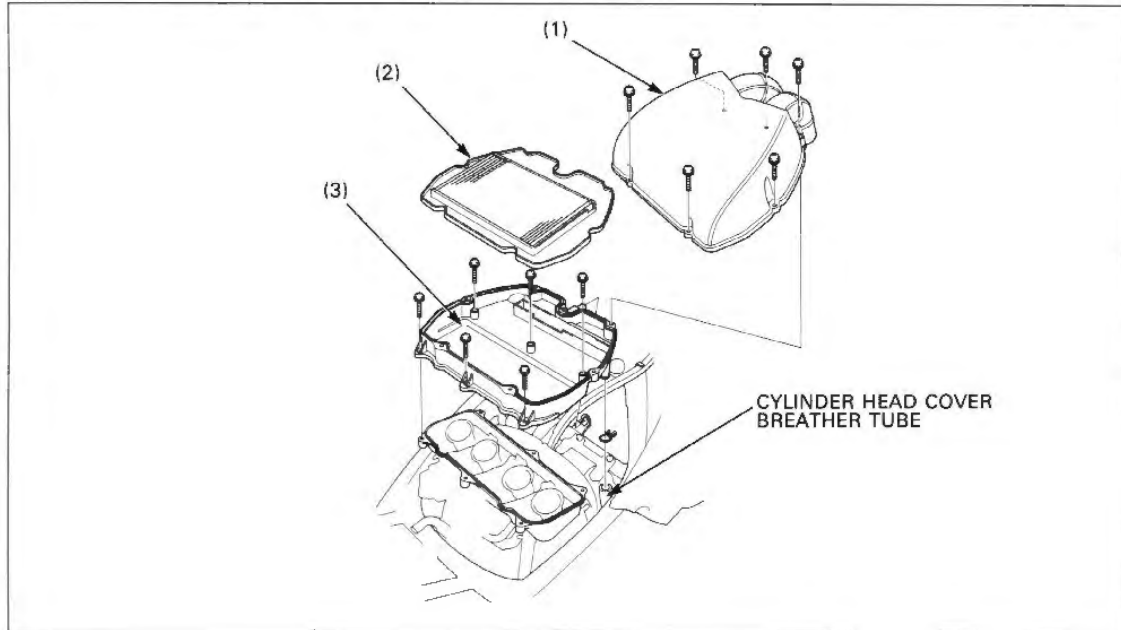

Requisite Service

- Fuel tank removal/installation (page 2-11)

Procedure	Q'ty	Remarks
Removal Order		
(1) Air cleaner housing cover	1	Installation is in the reverse order of removal • Before removing the air cleaner base, disconnect the cylinder head cover breather tube from the air cleaner base. • When installing, align the boss on the front end of the air cleaner base with the hook on the frame.
(2) Air cleaner element	1	
(3) Air cleaner base	1	

Carburetor Removal/Installation

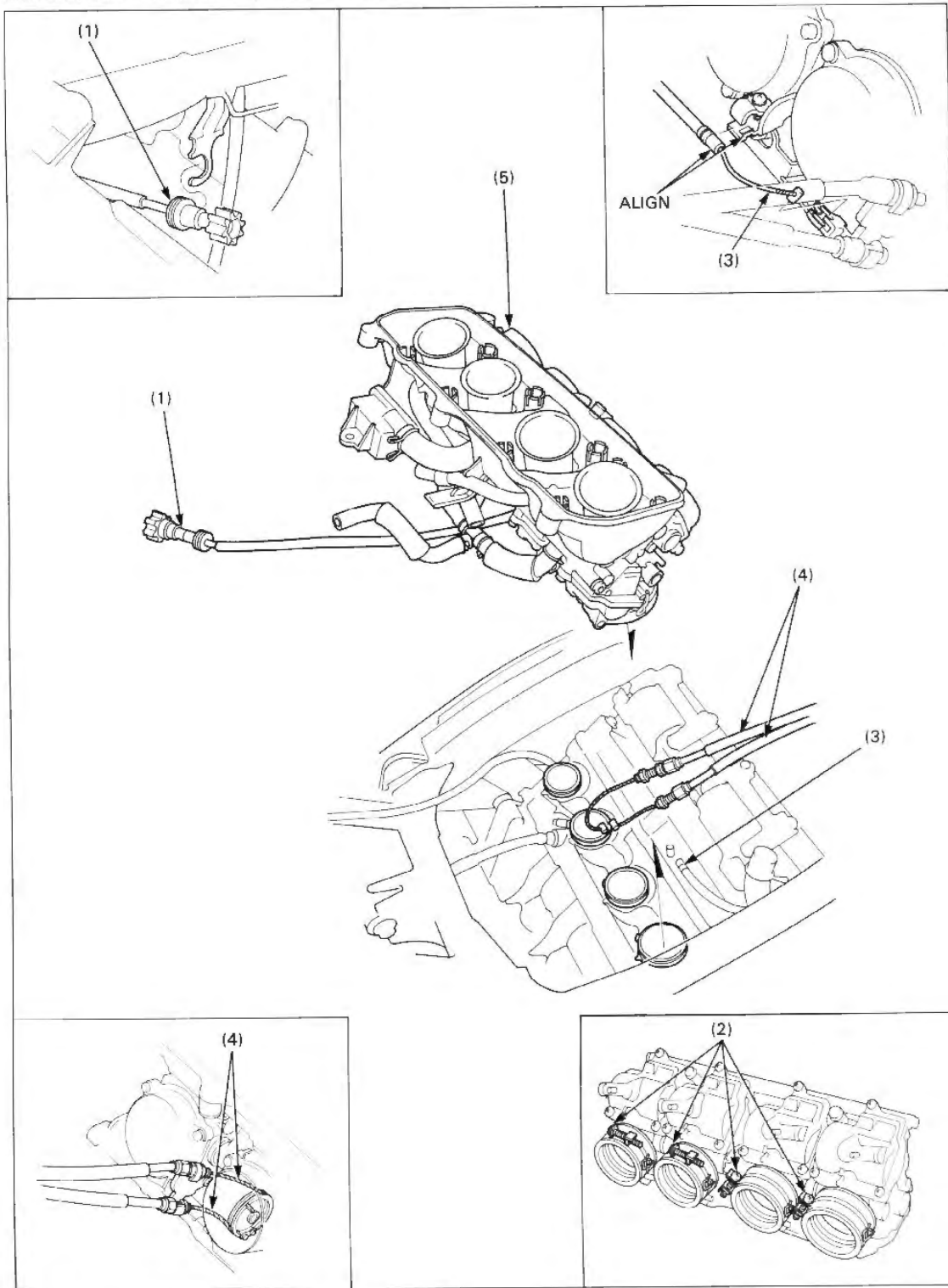

▲ WARNING

• Gasoline is extremely flammable and is explosive under certain conditions.

- Work in a well ventilated area. Smoking or allowing flames or sparks in the work area where gasoline is stored can cause a fire or explosion.

NOTE

• Route each tube correctly referring page 1-20.

Requisite Service

- Air cleaner housing removal/installation (page 6-3)

Procedure		Q'ty	Remarks
	Removal Order		Installation is in the reverse order of removal.
(1)	Throttle stop screw	1	
(2)	Carburetor insulator band screw	4	Only loosen.
(3)	Choke cable	1	
(4)	Throttle cable	2	
(5)	Carburetor assembly	1	NOTE
			• After removing the carburetor assembly, do not place it up side down or the air intake might be deformed.

Carburetor Separation

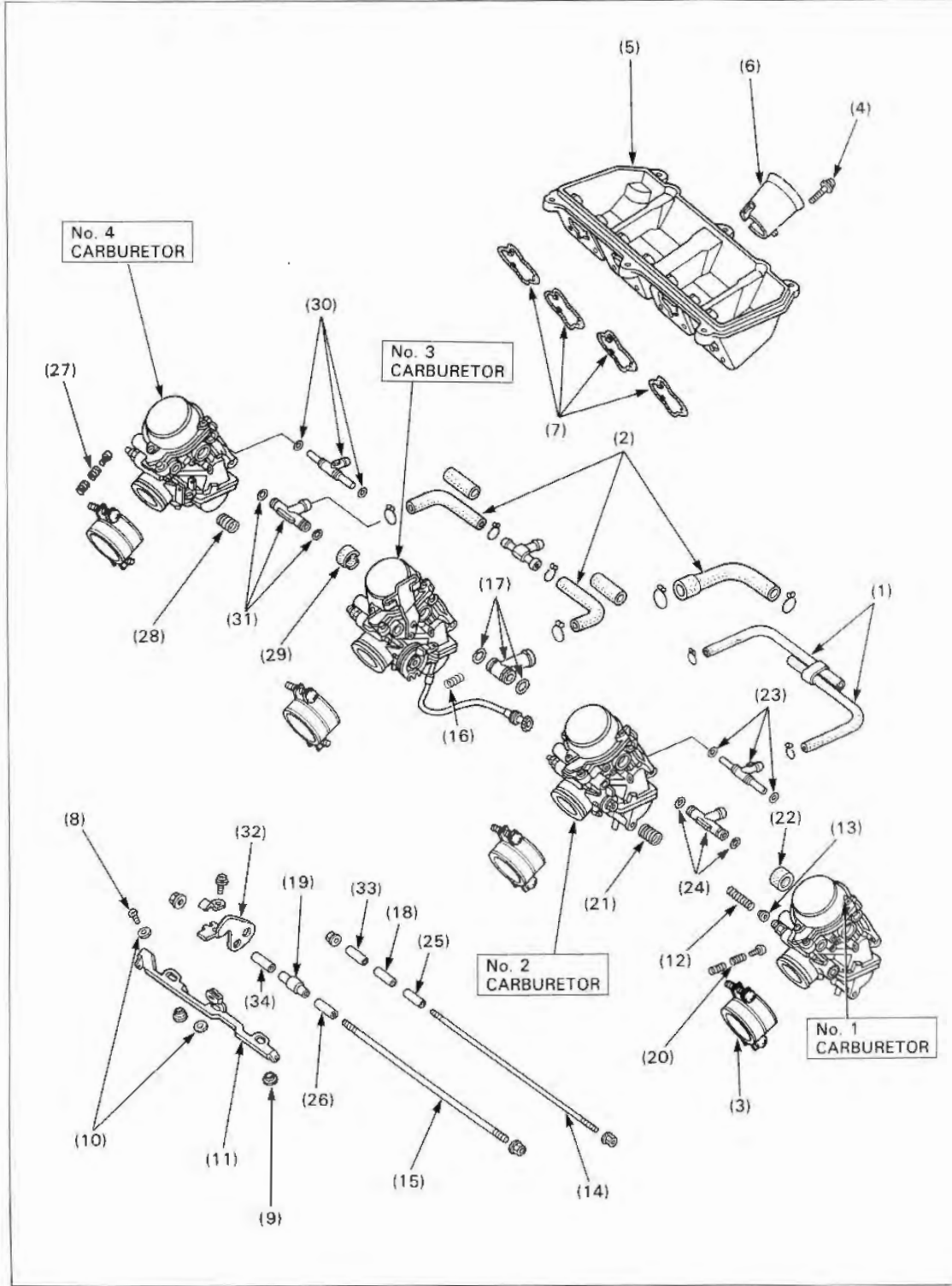



Requisite Service

- Carburetor removal (page 6-4).

Procedure		Q'ty	Remarks
Separate No3./No.4 carb. from No1./No.2 carb.			
(1)	Carburetor breather tube	2	
(2)	Carburetor fuel tube	3	
(3)	Carburetor insulator	4	
(4)	Screws	16	
(5)	Air chamber	1	
(6)	Air intake	4	
(7)	O-ring	4	
(8)	Starting enrichment valve arm screw	2	
(9)	Plastic collar	2	
(10)	Plastic washer	2	
(11)	Starting enrichment valve arm	1	
(12)	Thrust spring	1	
(13)	Spring seat	1	
(14)	Carburetor connecting bolt/nut (5mm)	1/2	NOTE • Loosen each nut gradually and alternately.
(15)	Carburetor connecting bolt/nut (6mm)	1/2	
(16)	No2. carb. synchronization spring	1	
(17)	Air joint pipe (3-way)/O-ring	1/2	
(18)	Dowel pin (5mm bolt)	1	
(19)	Collared dowel pin (6mm bolt)	1	
Separate No1. carb. from No.2 carb.			
(20)	No1. carb. synchronization spring	1	
(21)	Thrust spring	1	
(22)	Air joint pipe (rubber)	1	
(23)	Air vent pipe (3-way)/O-ring	1/2	
(24)	Fuel joint pipe (3-way)/O-ring	1/2	
(25)	Dowel pin (5mm bolt)	1	
(26)	Dowel pin (6mm bolt)	1	
Separate No3. carb. from No. 4 carb.			
(27)	No4. carb. synchronization spring	1	
(28)	Thrust spring	1	
(29)	Air joint pipe (rubber)	1	
(30)	Air vent pipe (3-way)/O-ring	1/2	
(31)	Fuel joint pipe (3-way)/O-ring	1/2	
(32)	Starting enrichment valve cable holder	1	
(33)	Dowel pin (5mm bolt)	1	
(34)	Dowel pin (6mm bolt)	1	

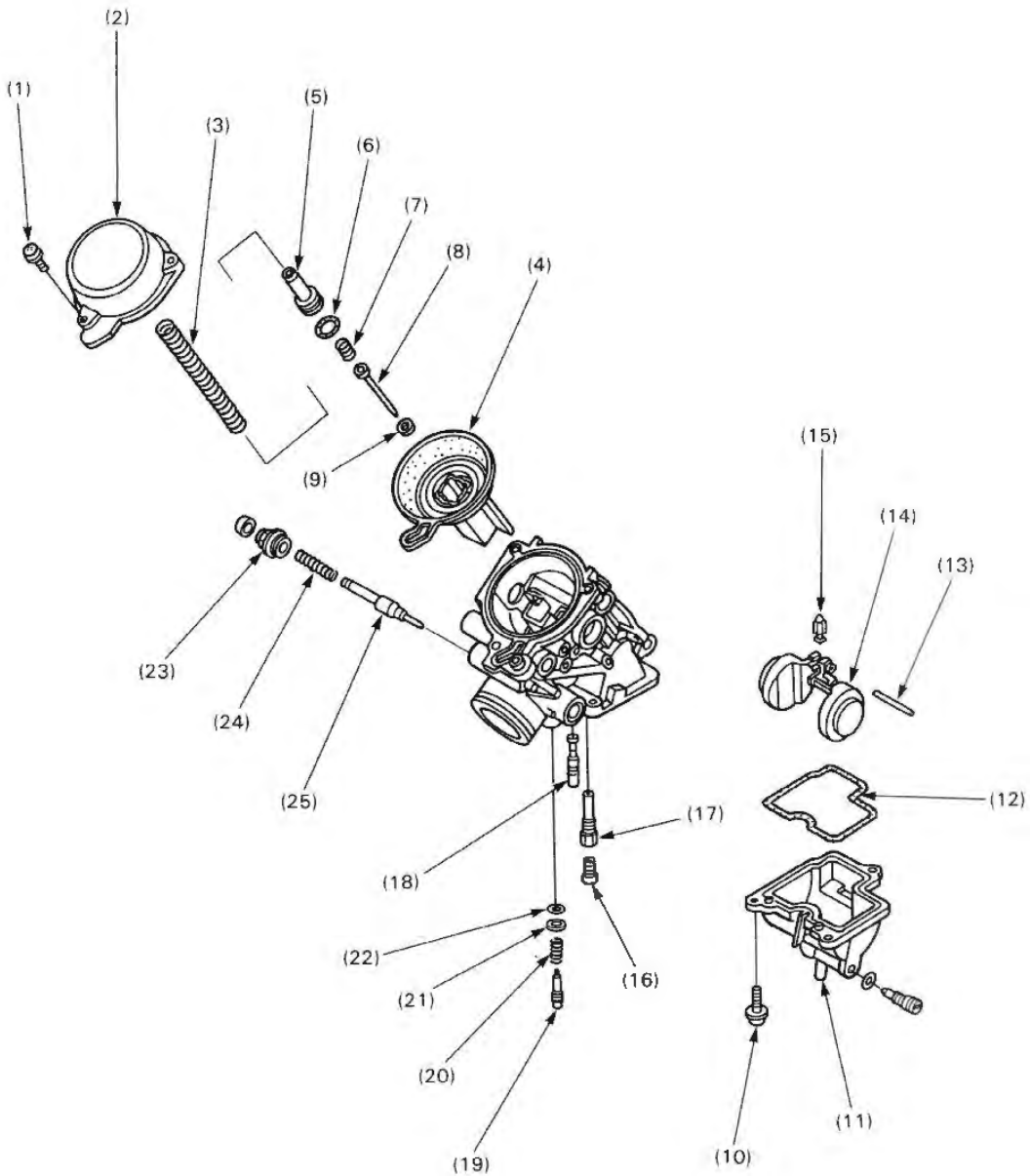
Carburetor Disassembly/Assembly



O-rings: 

NOTE

- Vacuum chambers, float chambers and jets can be serviced without separating the carburetors.
- Keep the carburetor parts separate from the other carburetor's so you can install the parts to the original positions.

Requisite Service

- Carburetor separation (page 6-6)
- Carburetor combination (page 6-10)

Procedure	Q'ty	Remarks
Disassembly Order Vacuum chamber disassembly (1) Vacuum chamber cover screws (2) Vacuum chamber cover (3) Diaphragm spring (4) Diaphragm/Vacuum piston (5) Jet needle holder (6) O-ring (7) Jet needle holder spring (8) Jet needle (9) Washer	3 1 1 1 1 1 1 1 1	Assembly is in the reverse order of disassembly. When installing, be careful not to bend the spring. When installing, align the tab of the diaphragm with the cut out in the carburetor body.
Float chamber disassembly (10) Float chamber cover screws (11) Float chamber (12) O-ring (13) Float pin (14) Float (15) Float valve (16) Main jet (17) Needle jet holder (18) Slow jet (19) Pilot screw (20) Spring (21) Washer (22) O-ring	3 1 1 1 1 1 1 1 1 1 1 1	Refer to page 1-6 for number of turning out.
Starting enrichment valve disassembly (23) Valve nut (24) Spring (25) Starting enrichment valve	1 1 1	

Jet Needle Holder Removal/Installation

Remove the vacuum piston.

Screw a proper 4 mm thread screw in the jet needle holder as shown and pull out the jet needle holder with a pliers.

NOTE

- Be careful not damage the diaphragm.
- Do not remove the jet needle holder by pushing in the jet needle.

Install the jet needle holder in the reverse order of removal.

NOTE

- Push the jet needle holder in until the O-ring on the holder seats completely in the groove in the vacuum piston.

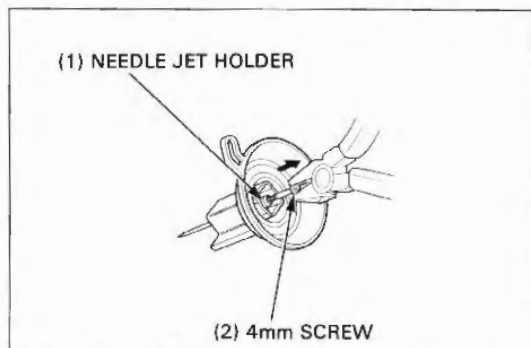

Requisite Service

• Carburetor installation (page 6-4)

Procedure		Q'ty	Remarks
Assemble No. 1 carb. with No. 2 carb.			No. 2 carburetor is the base carburetor.
(1)	Dowel pin (6 mm bolt)	1	
(2)	Dowel pin (5 mm bolt)	1	
(3)	Fuel joint pipe (3-way)/O-ring	1/2	
(4)	Air vent pipe (3-way)/O-ring	1/2	
(5)	Air joint pipe (rubber)	1	
(6)	Thrust spring	1	
(7)	No. 1 carb. synchronization spring	1	
Assemble No. 3 carb. with No. 4 carb.			
(8)	Dowel pin (6 mm bolt)	1	
(9)	Dowel pin (5 mm bolt)	1	
(10)	Starting enrichment valve cable holder	1	
(11)	Fuel joint pipe (3-way)/O-ring	1/2	
(12)	Air vent pipe (3-way)/O-ring	1/2	
(13)	Air joint pipe (rubber)	1	
(14)	Thrust spring	1	
(15)	No. 4 carb. synchronization spring	1	
Assemble No. 1/No. 2 carb. with No. 3/No. 4 carb.			
(16)	Collared dowel pin (6 mm bolt)	1	
(17)	Dowel pin (5 mm bolt)	1	
(18)	Air joint pipe (3-way)/O-ring	1/2	
(19)	No. 2 carb. synchronization spring	1	
(20)	Carburetor connecting bolt/nut (6 mm)	1/2	NOTE
(21)	Carburetor connecting bolt/nut (5 mm)	1/2	• Tighten each nut gradually and alternately.
(22)	Spring seat	1	
(23)	Thrust spring	1	
(24)	Starting enrichment valve arm	1	
(25)	Plastic washer	2	
(26)	Plastic collar	2	
(27)	Starting enrichment valve arm screw	2	
(28)	O-ring	4	NOTE
			• Align the tang of the O-ring with the cut out in the carburetor.
(29)	Air intake	4	NOTE
			• Align the cut out in the end of the air intake with the groove in the carburetor.
(30)	Air chamber	1	
(31)	Screws	16	
(32)	Carburetor insulator	4	Align the insulator groove with the carburetor lug with the "UP ↑" mark facing carburetor.
(33)	Carburetor fuel tube	1	
(34)	Carburetor breather tube	2	

Pulse Secondary Air Injection (PAIR) Control Valve Removal/Installation (California Type Only)

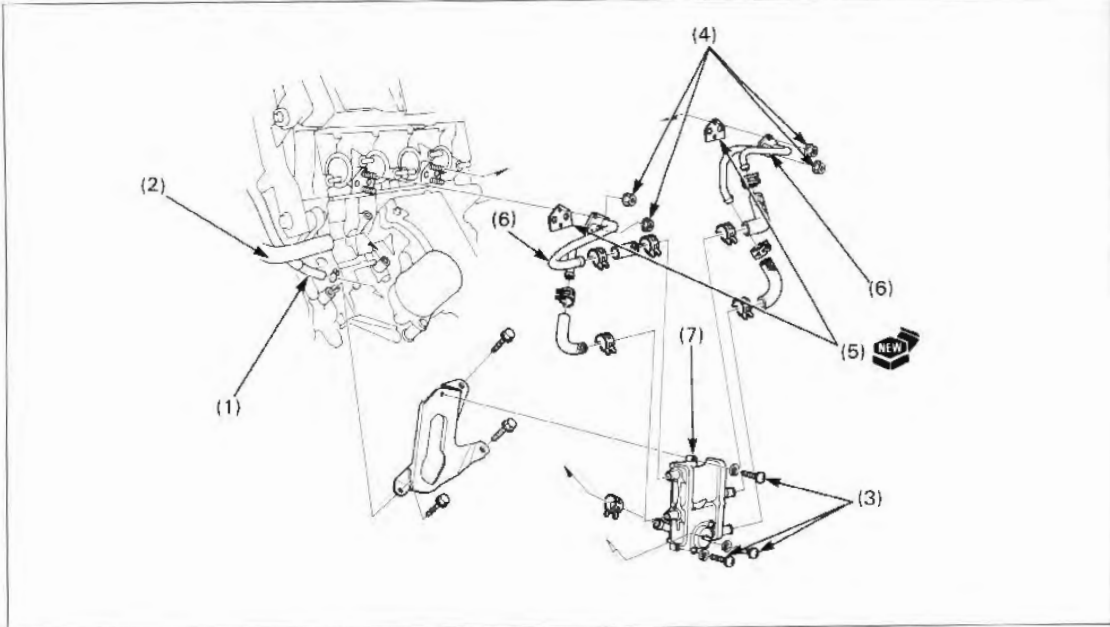

Requisite Service

- Side fairing removal/installation (page 2-3)

Procedure	Q'ty	Remarks
Removal Order		Installation is in the reverse order of removal.
(1) PAIR control valve control tube	1	
(2) PAIR control valve air intake hose	1	
(3) Screw/Spring washer	3/3	
(4) Air inlet pipe joint nut	4	
(5) Gasket	2	
(6) Air joint pipe	2	
(7) PAIR control valve	1	

Evaporative Emission (EVAP) Canister Removal/Installation (California Type Only)

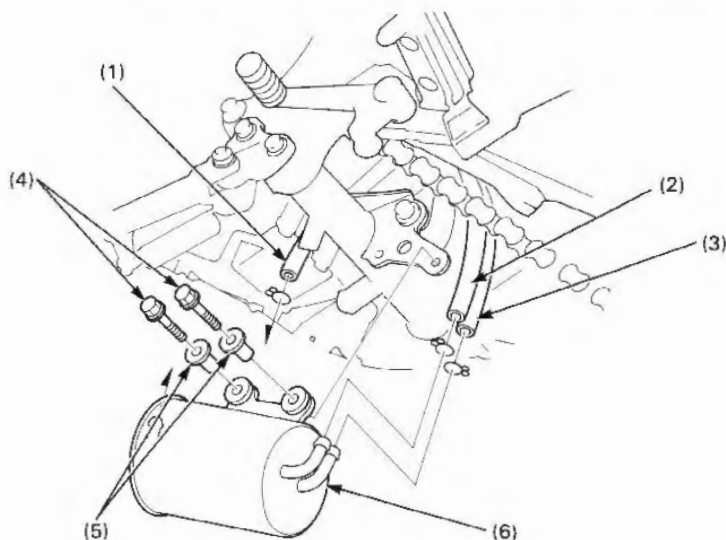

Requisite Service

- Side fairing removal/installation (page 2-3)

Procedure	Q'ty	Remarks
Removal Order		Installation is in the reverse order of removal.
(1) Air vent tube (#2)	1	Install the tubes according to the Vacuum Hose Routing Label on the air cleaner housing cover.
(2) EVAP canister to EVAP CAV control valve tube	1	
(3) EVAP canister to fuel tank tube (# 1)	1	
(4) Bolt	2	
(5) Flange collar	2	
(6) EVAP canister	1	

Pilot Screw Adjustment

Idle Drop Procedure

▲WARNING

- If the engine must be running to do some work, make sure the area is well ventilated. Never run the engine in an enclosed area. The exhaust contains poisonous carbon monoxide gas that may cause loss of consciousness and lead to death.

NOTE

- Make sure the carburetor synchronization is within specification before pilot screw adjustment (see page 1-6).
- The pilot screws are factory pre-set and no adjustment is necessary unless the pilot screws are replaced.
- Use a tachometer with graduations of 50 rpm change.

Remove the maintenance lid (page 2-3).

STOOL

Pilot screw wrench 49-state and California type:
 07KMA-MN90100 or
 07MMA-MV9010A
 Canada type: 07908-4730001

1. Turn each pilot screw clockwise until it seats lightly, then back it out to the specification given. This is an initial setting prior to the final pilot screw adjustment.

CAUTION

- **Damage to the pilot screw seat will occur if the pilot screw is tightened against the seat.**

Initial Opening: 49-states type: 2-1/8 turns out
 : California type: 2-3/4 turns out
 : Canada type: 2 turns out

2. Warm up the engine to operating temperature. Stop and go riding for 10 minutes is sufficient.
3. Attach a tachometer according to its manufacturer's instructions.
4. Adjust the idle speed to the specified rpm with the throttle stop screw.

Idle Speed: 49-states and Canada type:
 1,200 ± 100 rpm
 : California type: 1,400 ± 100 rpm

5. Turn all pilot screws 1/2 turn counterclockwise from the initial setting.
6. If the engine speed increases by 50 rpm or more, turn all pilot screws out by successive 1/2 turn increments until engine speed does not increase.
7. Adjust the idle speed with the throttle stop screw.
8. Turn the No. 3 carburetor pilot screw in until the engine speed drops 50 rpm.
9. Then turn the No. 3 carburetor pilot screw counterclockwise 1/2 turn from the position obtained in step 8.
10. Adjust the idle speed with the throttle stop screw.
11. Perform steps 8, 9 and 10 for the No. 1, 2 and 4 carburetor pilot screws.

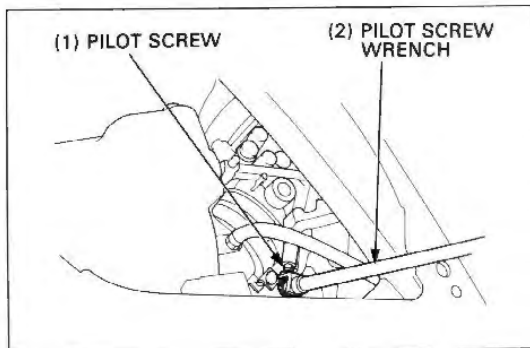

High Altitude Adjustment (U.S.A. Only)

When the vehicle is to be operated continuously above 2,000 m (6,500 feet), the carburetor must be readjusted as follows to improve driveability and decrease exhaust emissions. Warm up the engine to operating temperature. Stop and go riding for 10 minutes is sufficient. Turn each pilot screw to the High Altitude Setting specified below.

High Altitude Setting: 1/2 turn in

5 TOOL

Pilot screw wrench

**07KMA-MN90100 or
07MMA-MV9010A**

Adjust the idle speed to $1,200 \pm 100$ rpm (California: $1,400 \pm 100$ rpm) with the throttle stop screw.

NOTE

- This adjustment must be made at high altitude to ensure proper high altitude operation.

Attach a Vehicle Emission Control Information Update Label onto the frame under the left side cover as shown.

NOTE

- Do not attach the label to any part that can be easily removed from the vehicle.

WARNING

- Sustained operation at an altitude lower than 1,500 m (5,000 feet) with the carburetor adjusted for high altitude may cause the engine to idle roughly and stall in traffic. It may also cause engine damage due to overheating.

When the vehicle is to be operated continuously below 1,500 m (5,000 feet), turn each pilot screw to the Low Altitude Setting specified below.

Low Altitude Setting: 1/2 turn out

Adjust the idle speed to $1,200 \pm 100$ rpm (California: $1,400 \pm 100$ rpm) with the throttle stop screw.

Be sure to make these adjustments at low altitude. Remove the Vehicle Emission Control Update Label that is attached to the frame under the left side cover after adjusting for the low altitude.

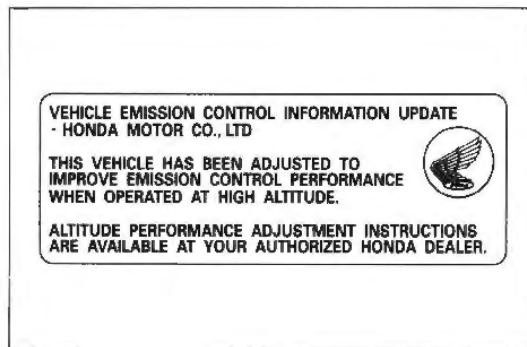
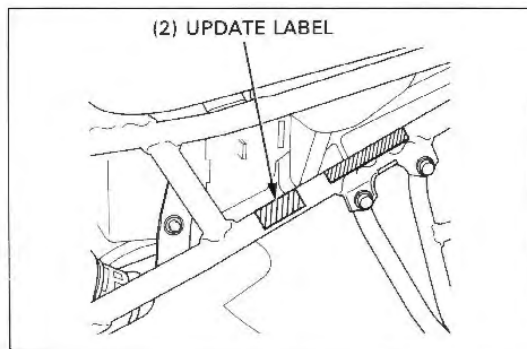
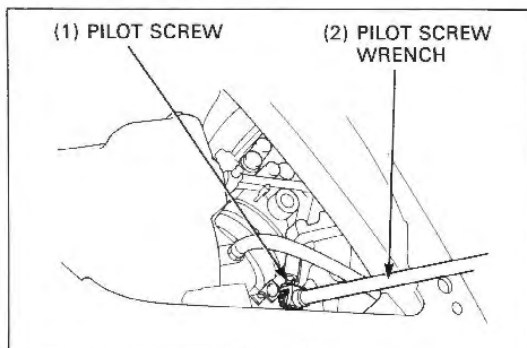

7. Engine Removal/Installation

Service Information

7-1 Engine Removal/Installation

7-2

Service Information

- A floor jack or other support is required to support and maneuver the engine.
Engine dry weight 60.7kg(133.8lb)
California type: 61.6kg (135.8 lb)

CAUTION

- **Do not jack up the motorcycle using the oil filter or oil cooler.**

- Parts requiring engine removal for servicing:
 - Crankcase, cylinder, piston (Section 10)
 - Crankshaft, transmission (not including the shift drum and shift forks) (Section 11)
- The following components can be serviced with the engine in the frame.
 - Water pump (Section 5)
 - Carburetor (Section 6)
 - Camshaft (Section 8)
 - Cylinder head (Section 8)
 - Clutch (Section 9)
 - Gear shift linkage (Section 9)
 - Shift drum and shift forks (Section 9)
 - Oil pump (Section 4)
 - Alternator (Section 15)
 - Ignition pulse generator (Section 16)

Engine Removal/Installation

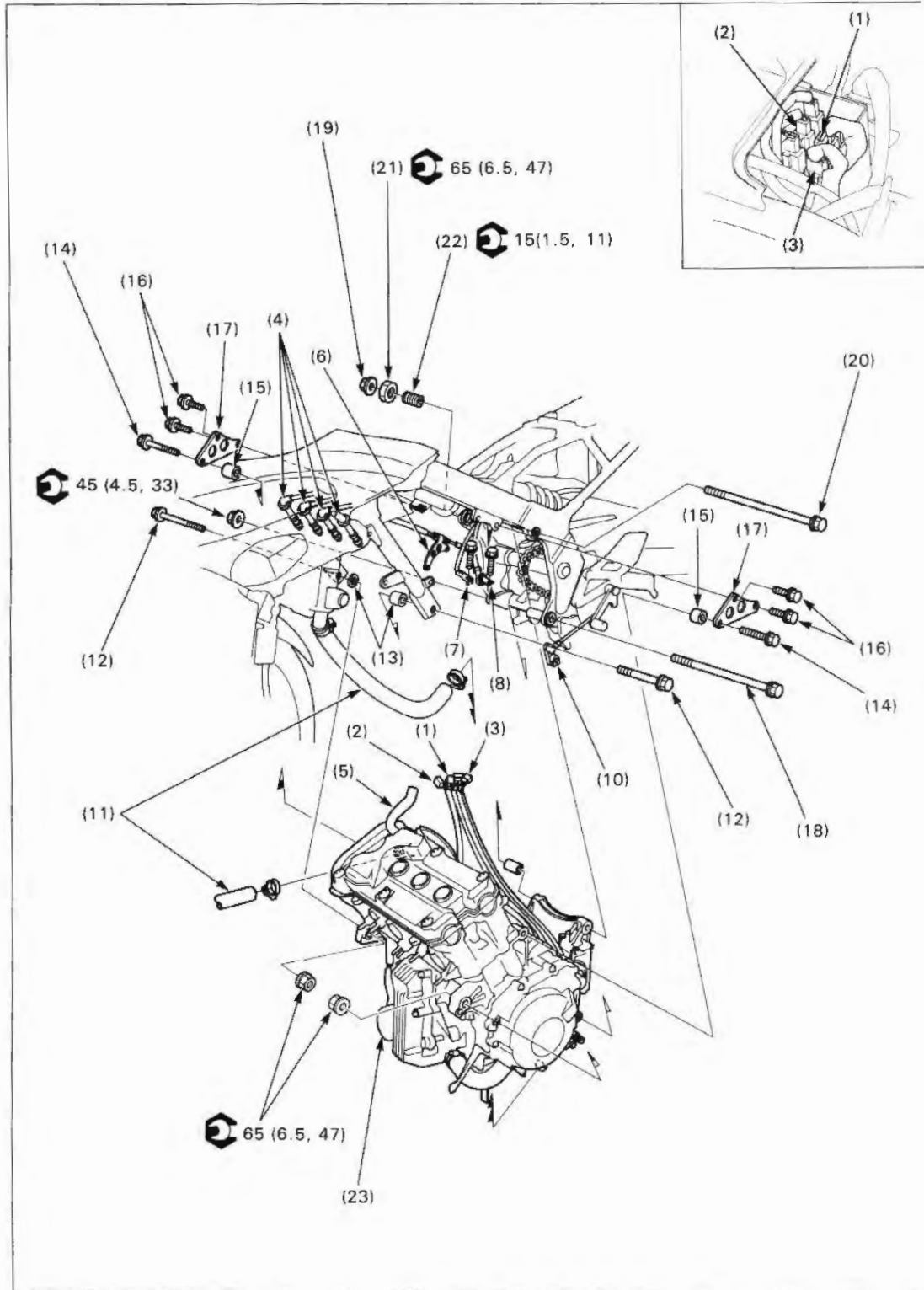

CAUTION

- Do not jack up the motorcycle using the oil filter or the oil cooler.

NOTE

- A floor jack or other adjustable support is required to support and maneuver the engine. The jack height must be continually adjusted to relieve stress for ease of bolt removal.
- Turn the ignition switch OFF and disconnect the battery ground cable.

Requisite Service

- Side fairing removal (page 2-3)
- Exhaust system removal/installation (page 2-10)

Procedure	Q'ty	Remarks
Removal Other		Installation is in the reverse order of removal.
(1) Alternator connector (3P)	1	
(2) Ignition pulse generator connector (2P mini)	1	
(3) 3P mini connector (oil pressure switch wire/ neutral switch wire/thermo sensor wire)	1	
(4) Spark plug cap	4	
(5) Cylinder head cover breather tube	1	
(6) Clutch cable holder	1	
(7) Starter motor ground wire	1	
(8) Starter motor wire	1	
(9) Drive sprocket	1	Refer to page 7-4 for removal and installation.
(10) Gearshift pedal link	1	Install the link with the punch marks on the link and gear- shift spindle.
(11) Water hose	2	Disconnect the water hoses at the engine side.
(12) Front engine hanger bolt	2	
(13) Collar (long/short)	1/1	Install the long one to the left hanger arm and the short one to the right.
(14) Engine hanger plate bolt (10mm)	2	
(15) Collar	2	
(16) Engine hanger plate bolt (8mm)	4	
(17) Engine hanger plate	2	
(18) Rear lower engine hanger bolt	1	
(19) Rear upper engine hanger nut	1	
(20) Rear upper engine hanger bolt	1	
(21) Engine hanger adjusting bolt lock nut	1	Refer to page 7-4 for installation.
(22) Engine hanger adjusting bolt	1	
(23) Engine assembly	1	NOTE • When placing the engine assembly on the floor, be careful to set the engine down gently on the floor to prevent bending or breaking the support fins on the oil pan.

Drive Sprocket Removal/Installation

Remove the following:

- drive sprocket cover bolts
- clamp
- drive sprocket cover
- drive chain guide
- drive sprocket bolt
- washer
- drive sprocket

Install the removed parts in the reverse order of removal.

Torque:

Drive sprocket bolt: 55N·m (5.5kg-m, 40ft-lb)

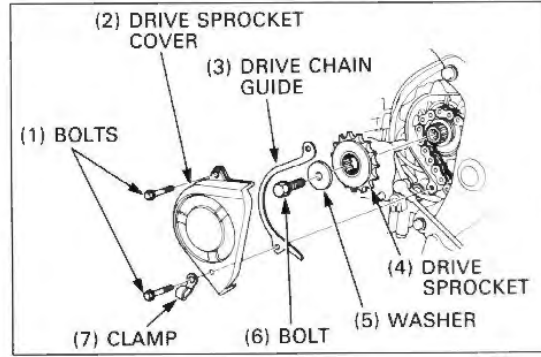

Engine Hanger Adjusting Bolt/Lock Nut Installation

Install the engine hanger adjusting bolt so that its edge does not protrude from the frame's inner surface.

Install the rear upper engine hanger bolt through the frame, engine, collar and the adjusting bolt.

Push the rear upper engine hanger bolt so that you can tighten the adjusting bolt with a hexagonal wrench.

Torque: 15N·m (1.5kg-m, 11ft-lb)

Tighten the lock nut while holding the adjusting bolt with a hexagonal wrench.

Torque: 65N·m (6.5kg-m, 47ft-lb)

Push the rear upper engine hanger bolt fully and tighten the nut.

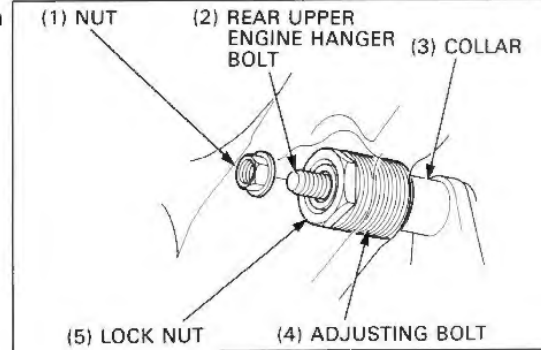

8. Cylinder Head

Service Information	8-1	Cylinder Head Removal/Installation	8-7
Troubleshooting	8-1	Cylinder Head Disassembly/Assembly	8-8
Camshaft Removal/Installation	8-2		

Service Information

- This section covers service procedures for the cylinder head, valves, camshaft and cylinder. Cylinder head removal/installation can be performed with the engine in the frame.
- When disassembling, mark and store the disassembled parts to ensure they are reinstalled in their original locations.
- Clean all disassembled parts with clean solvent and dry them by blowing them off with compressed air before inspection.
- Pour clean engine oil into the oil pockets in the cylinder head during assembly to lubricate the camshaft lobes.

Troubleshooting

- Engine top end problems usually affect engine performance. These can be diagnosed by a compression or leak-down test, or by tracing noises to the top-end with a sounding rod or stethoscope.

Compression Too Low, Hard Starting Or Poor Performance At Low Speed

- Valves
 - Incorrect valve adjustment
 - Burned or bent valves
 - Incorrect valve timing
 - Broken valve spring
 - Weak valve spring
- Cylinder head
 - Leaking or damaged head gasket
 - Warped or cracked cylinder head
 - Loose spark plug

Compression Too High

- Excessive carbon build-up in cylinder head or on top of piston

Excessive Smoke

- Worn valve stem or valve guide
- Damaged stem seal

Excessive Noise

- Incorrect valve adjustment
- Sticking valve or broken valve spring
- Damaged or worn camshaft
- Loose, worn or damaged cam chain
- Worn or damaged cam chain tensioner
- Worn cam sprocket teeth

Rough Idle

- Low cylinder compression
- Intake air leak

Camshaft Removal/Installation

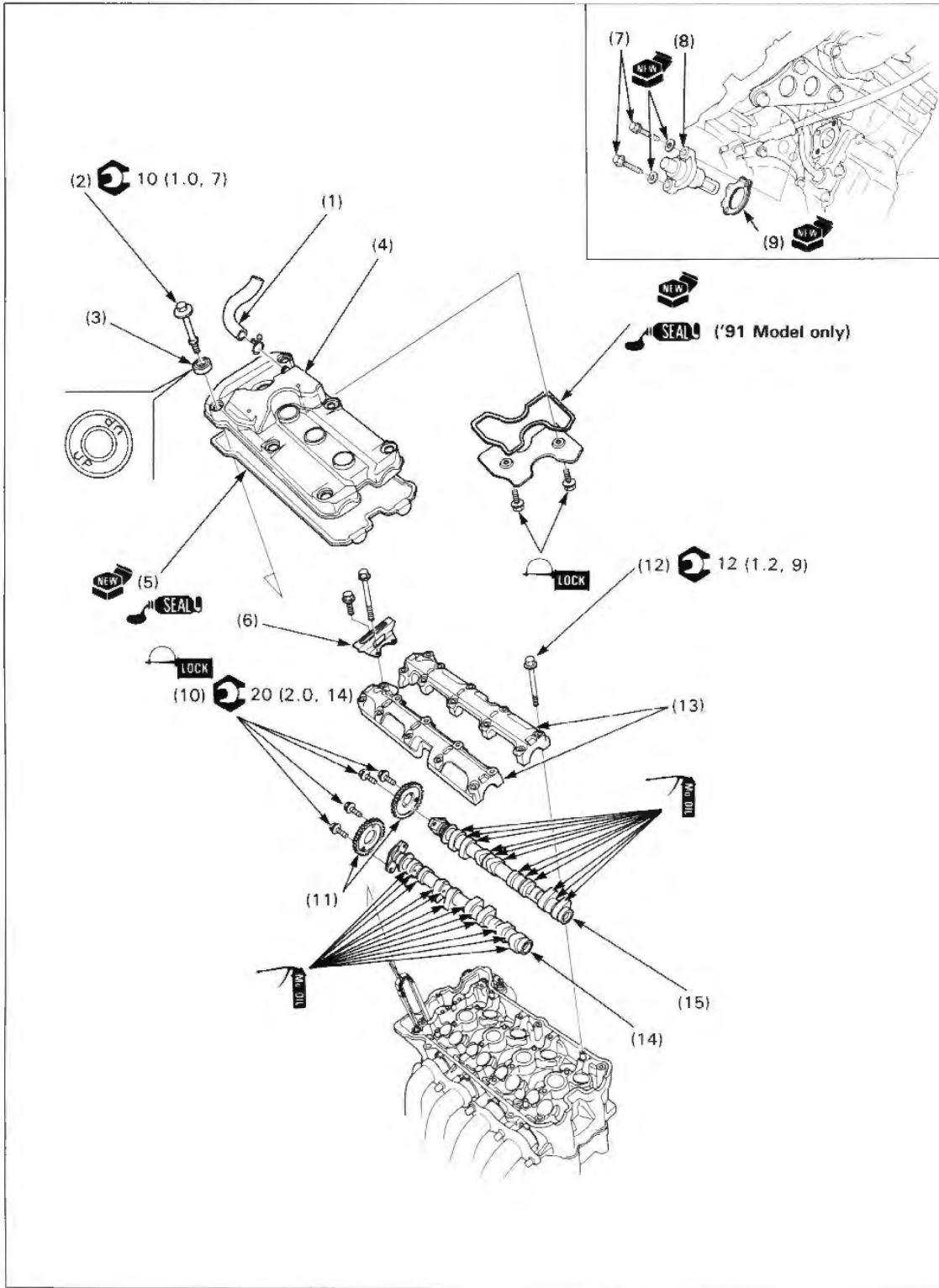

Requisite Service

- Side fairing removal/installation (page 2-3)

- Swing the radiator forward (page 3-5)

Procedure	Q'ty	Remarks
Removal Order		Installation is in the reverse order of removal.
(1) Cylinder head cover breather tube	1	
(2) Cylinder head cover bolt	6	
(3) Washer	6	Install the washers with the "UP" mark facing up.
(4) Cylinder head cover	1	NOTE
		• Before installing, make sure that the cylinder head cover gasket is completely seated on the cylinder head cover, especially around the spark plug holes.
(5) Cylinder head cover gasket	1	NOTE
		• Apply Three Bond 1521 or equivalent to the cylinder head cover and install the gasket onto the cover.
(6) Cam chain cover	1	
(7) Cam chain tensioner bolt	2	
(8) Cam chain tensioner	1	Refer to page 8-6 for installation.
(9) Gasket	1	NOTE
		• Install the gasket with the slit facing out.
(10) Cam sprocket bolt	4	NOTE
		• Be careful not to drop the bolts into the crankcase.
		• After removing the bolts, clean the locking agent off the bolt threads and the bolt holes in the cam sprockets.
(11) Cam sprocket	2	NOTE
		• After removing the cam chain from the sprockets, suspend the cam chain with a piece of wire.
(12) Camshaft holder bolt	20	CAUTION
		• From the outside to the inside, loosen the bolts in a crisscross pattern in several steps or camshaft holder might break.
(13) Camshaft holder	2	
(14) Exhaust (EX) camshaft	1	Refer to page 8-4 for installation.
(15) Intake (IN) camshaft	1	

Camshaft Installation

Remove the ignition pulse generator rotor cover cap.

(1) IGNITION PULSE GENERATOR COVER CAP

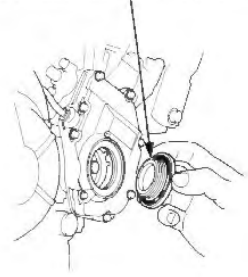

Align the T mark (notch mark) with the index mark on the ignition pulse generator rotor cover by turning the crankshaft clockwise.

(1) T MARK

(2) INDEX MARK

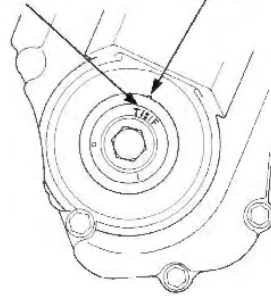

Apply molybdenum disulfide oil (a 50/50 mixture of engine oil and molybdenum disulfide grease) to the camshaft journals of the cylinder head and camshaft holders.

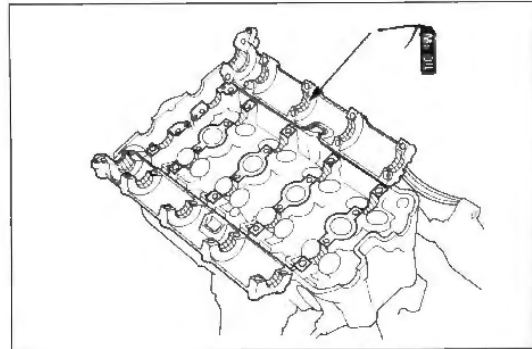

Install the camshafts onto the cylinder head with the cam lobes for the No. 1 cylinder facing up as shown.

NOTE

- Install each camshaft to the correct side. Each camshaft has an identification mark; "IN" is for the intake side and "EX" is for the exhaust side.

(1) INTAKE CAMSHAFT

(2) IDENTIFICATION MARKS

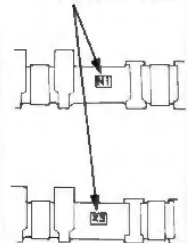
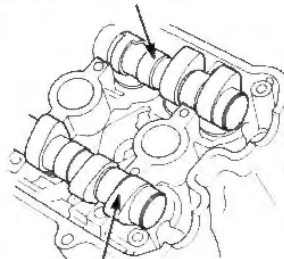

(3) EXHAUST CAMSHAFT

Install the camshaft holders onto the camshafts.

Install the longer bolts into the outer bolt holes and the shorter ones into the inner, and tighten the camshaft holder bolts in the numerical order casted on the camshaft holders.

CAUTION

- Do not tighten the camshaft holder bolts at this time. Tightening the camshaft holder bolts on only one-side might cause a camshaft holder to break.

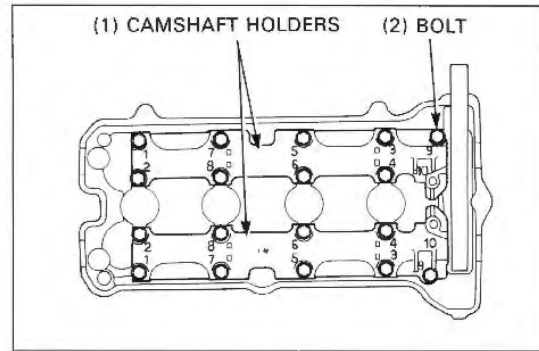

Make sure that the T mark (notch mark) aligns with the index mark on the ignition pulse generator rotor cover.

Install the cam chain over the cam sprockets.

Install the cam sprockets onto the camshaft flange with the timing marks on the cam sprockets aligning with the cylinder head upper surface, facing opposite each other.

NOTE

- Install each cam sprocket to the correct camshaft. Each cam sprocket has an identification mark; "IN" is for the intake side and "EX" is for the exhaust side.

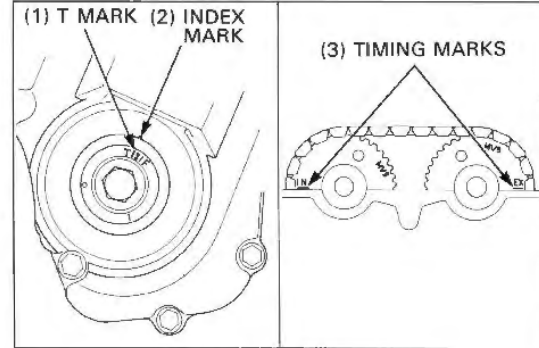

Before tightening the bolts, clean the locking agent off the bolt threads and the bolt holes in the cam sprockets.

Apply a locking agent to the threads of the cam sprocket bolts and tighten the two bolts loosely.

Turn the crankshaft clockwise 1/2 turn (180°) and tighten the other two bolts to the specified torque.

Torque: 20N·m (2.0kg·m, 14ft·lb)

Turn the crankshaft clockwise 1/2 turn (180°) and tighten the other two bolts to the specified torque.

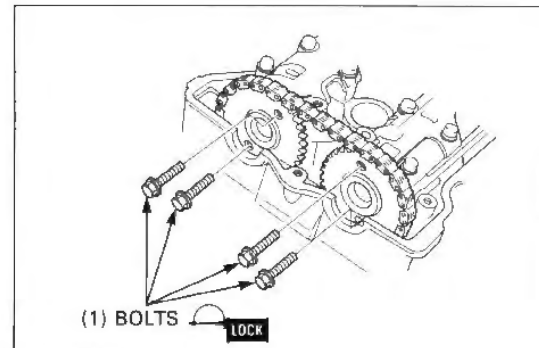

Install the cam chain cover and secure it with the bolts.

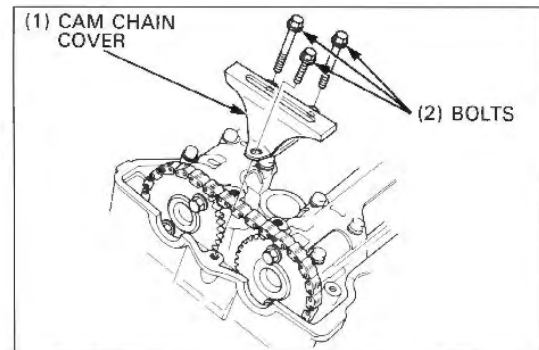

Cylinder Head

Submerge the cam chain tensioner in clean engine oil. Fill the cam chain tensioner with engine oil by pumping it until air bubbles stop coming out.

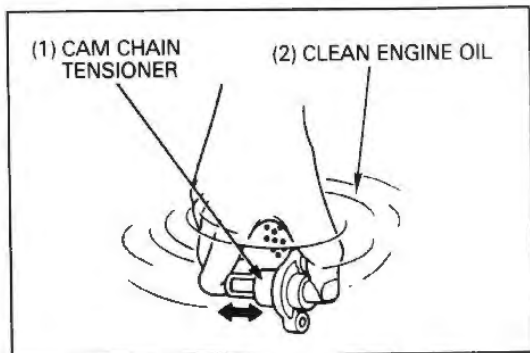

Install a new gasket onto the cam chain tensioner in the direction shown. If it is installed incorrectly, there will be too much oil pressure against the tensioner.

CAUTION

- If the gasket is installed incorrectly, the cam chain tensioner will wear out prematurely.

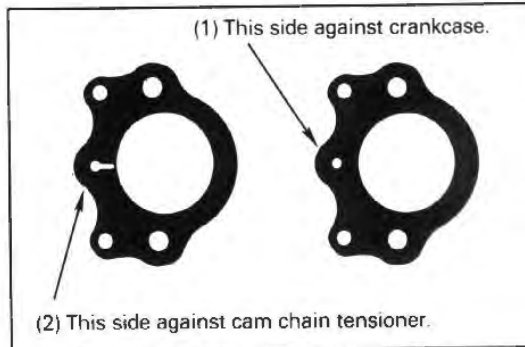

Install the cam chain tensioner and new sealing washers, and tighten the bolts gradually in a criss cross pattern.

Torque: 10 N·m (1.0 kg-m, 7 ft-lb)

After installing the cam chain tensioner, make sure the timing marks on the cam sprockets align with the cylinder head upper surface while facing opposite each other.

Install the cylinder head cover (page 8-3).

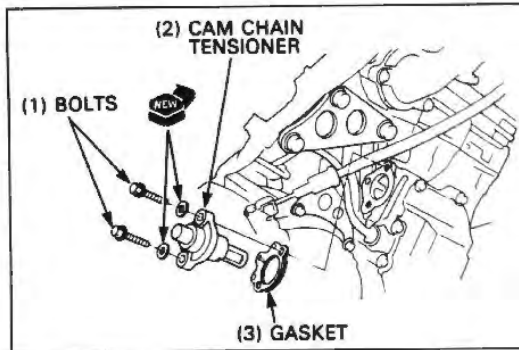

Cylinder Head Removal/Installation

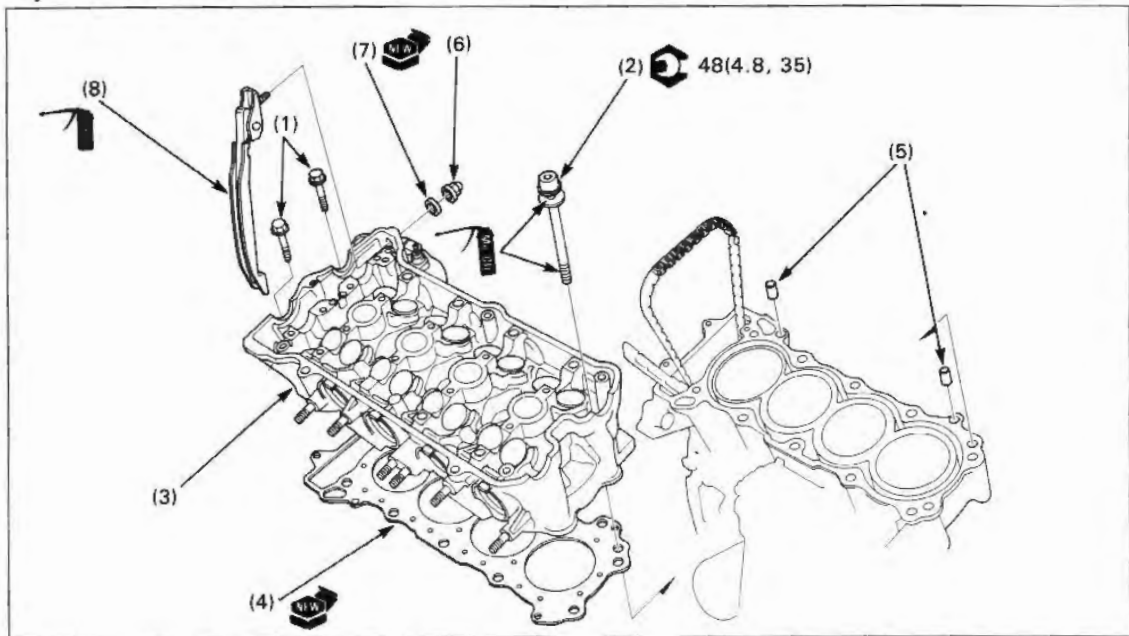

Requisite Service

- Exhaust system removal/installation (page 2-10)

- Camshaft removal/installation (page 8-2)

Procedure	Q'ty	Remarks
Removal Order		Installation is in the reverse order of removal.
(1) Cylinder head bolt (6mm)	2	
(2) Cylinder head bolt (9mm)/Sealing washer	10/10	From the outside to the inside, loosen the bolts in a crisscross pattern in several steps.
(3) Cylinder head assembly	1	Suspend the cam chain with a piece of wire to prevent the chain from falling into the crankcase.
(4) Gasket	1	
(5) Dowel pin	2	
(6) Cap nut	1	
(7) Sealing washer	1	
(8) Cam chain tensioner slider	1	

Cylinder Head Disassembly/Assembly

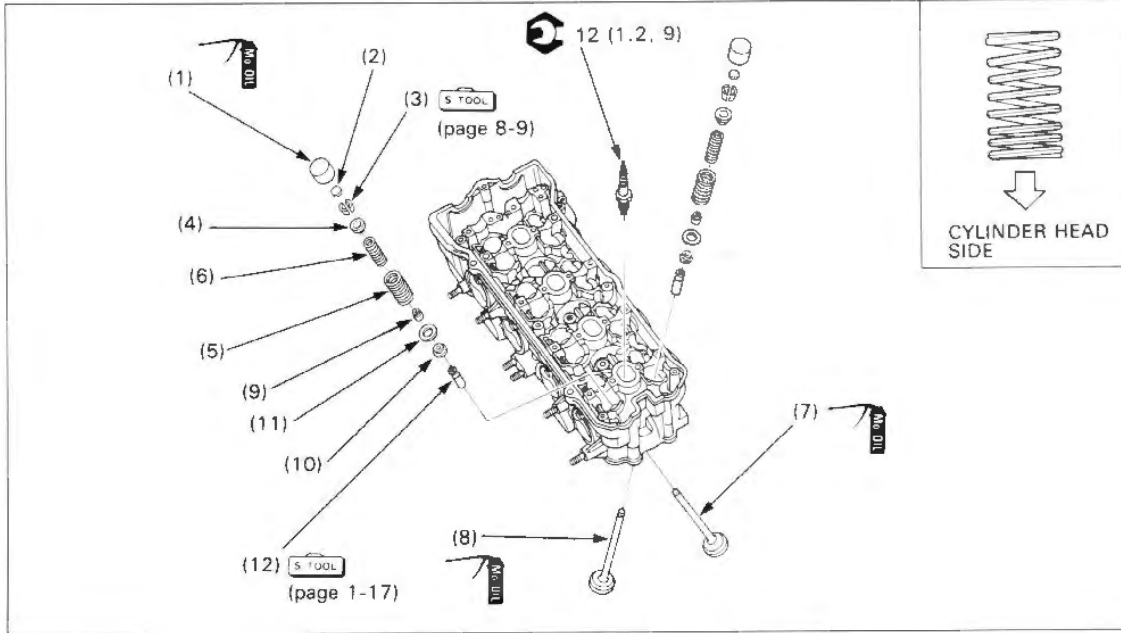

NOTE

- Store the valve components in the same order they were installed so they can be reinstalled in their or original locations.
- Refer to section 9 of the Common Service Manual for valve guide inspection/replacement.

Requisite Service

- Cylinder head removal/installation (page 8-7)

Procedure	Q'ty	Remarks
(1) Removal Order Valve lifter	16	Installation is in the reverse order of removal. NOTE • Remove the valve lifters using a hand lapping tool. Do not damage the cylinder head-valve lifter sliding surfaces.
(2) Valve shim	16	
(3) Valve cotter	32	Refer to page 8-9 for removal/installation.
(4) Retainer	16	
(5) Outer valve spring	16	Install the valve springs with the narrow pitch end facing down.
(6) Inner valve spring	16	
(7) Intake valve	8	U.S.A. only procedure: - using a marker, mark the valve guide with a line at the correct height as specified below. - chill the guides. - drive in the valve guide as shown to the line. - check the projection height with calipers to verify they are within specification.
(8) Exhaust valve	8	
(9) Stem seal	16	
(10) Inner spring seat	16	
(11) Outer spring seat	16	
(12) Valve guide	16	

Valve Cotters Removal/Installation

Remove the valve lifters and shims.

NOTE

- Do not allow shims to fall into the crankcase. The shim(s) may occasionally stick to the valve lifter.
- Mark the positions of all valve lifters and shims to ensure correct reassembly.
- It is easy to remove the valve lifter with a valve lapping tool or magnet.
- Remove the shims with tweezers or a magnet.

Install the tappet hole protector into the valve lifter sliding surface.

TOOL

Tappet hole protector

07HMG-MR70002

An equivalent tool can easily be made from a plastic 35mm film container by using the measurements shown below.

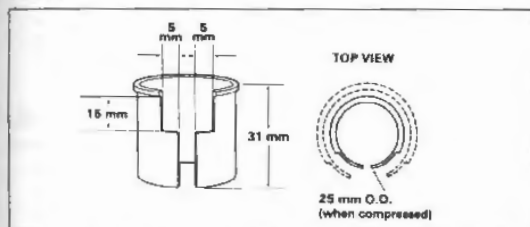

Install the valve spring compressor onto the valve and compress the valve spring.

CAUTION

- Do not compress the valve springs more than necessary to remove the valve cotters or they might be fatigued.

Remove (or install) the valve cotters.

TOOL

Valve spring compressor attachment 07959-KM30101

Valve spring compressor

07757-0010000

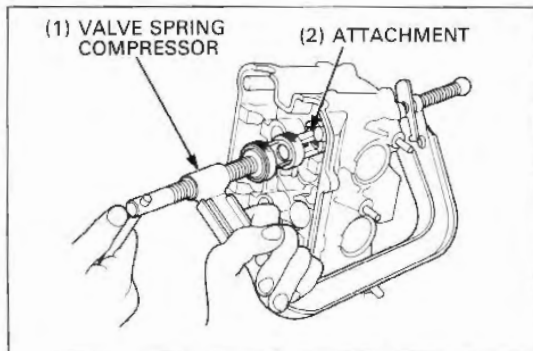
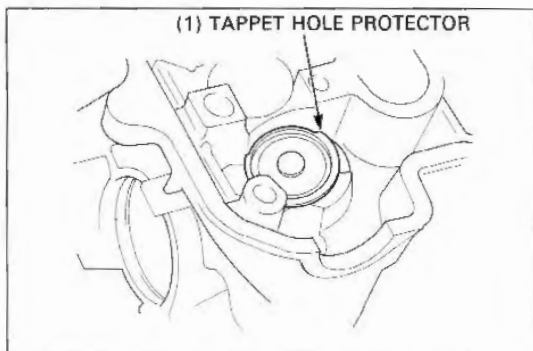

9. Clutch/Gearshift Linkage

Service Information	9-1	Gearshift Linkage Removal/Installation	9-8
Troubleshooting	9-1	Shift Drum/Shift Forks Removal/Installation	9-10
Right Crankcase Cover Removal/Installation	9-2	Clutch Installation	9-12
Clutch Removal	9-4		

Service Information

- This section covers removal and installation of the right crankcase cover, clutch, gearshift linkage, shift drum and shift forks. These services can be performed with the engine in the frame.

Troubleshooting

Clutch Lever Too Hard To Pull In

- Damaged, kinked or dirty clutch cable
- Damaged clutch lifter mechanism
- Faulty clutch lifter bearing
- Clutch lifter rod installed improperly

Clutch Will Not Disengage Or Vehicle Creeps With Clutch Disengaged

- Too much clutch lever free play
- Warped clutch plate
- Loose clutch lock nut
- Oil level too high, improper oil viscosity or oil additive used
- Damaged clutch lifter mechanism
- Clutch lifter rod installed improperly

Clutch Slips

- Clutch lifter slipping
- Worn clutch discs
- Weak clutch springs
- No clutch lever free play
- Additive in engine oil

Clutch Operation Feels Rough

- Rough outer drum slots

Hard To Shift

- Misadjusted clutch cable
- Improper oil viscosity
- Bent gearshift spindle
- Bent shift forks
- Bent shift fork shaft
- Bent fork claw
- Damaged shift drum cam grooves

Jumps Out Of Gear

- Damaged stopper arm
- Stopper arm spring fatigue
- Damaged shifter cam
- Damaged or bent shift fork
- Bent shift fork shaft
- Worn gear engagement dogs or slots

Right Crankcase Cover Removal/Installation

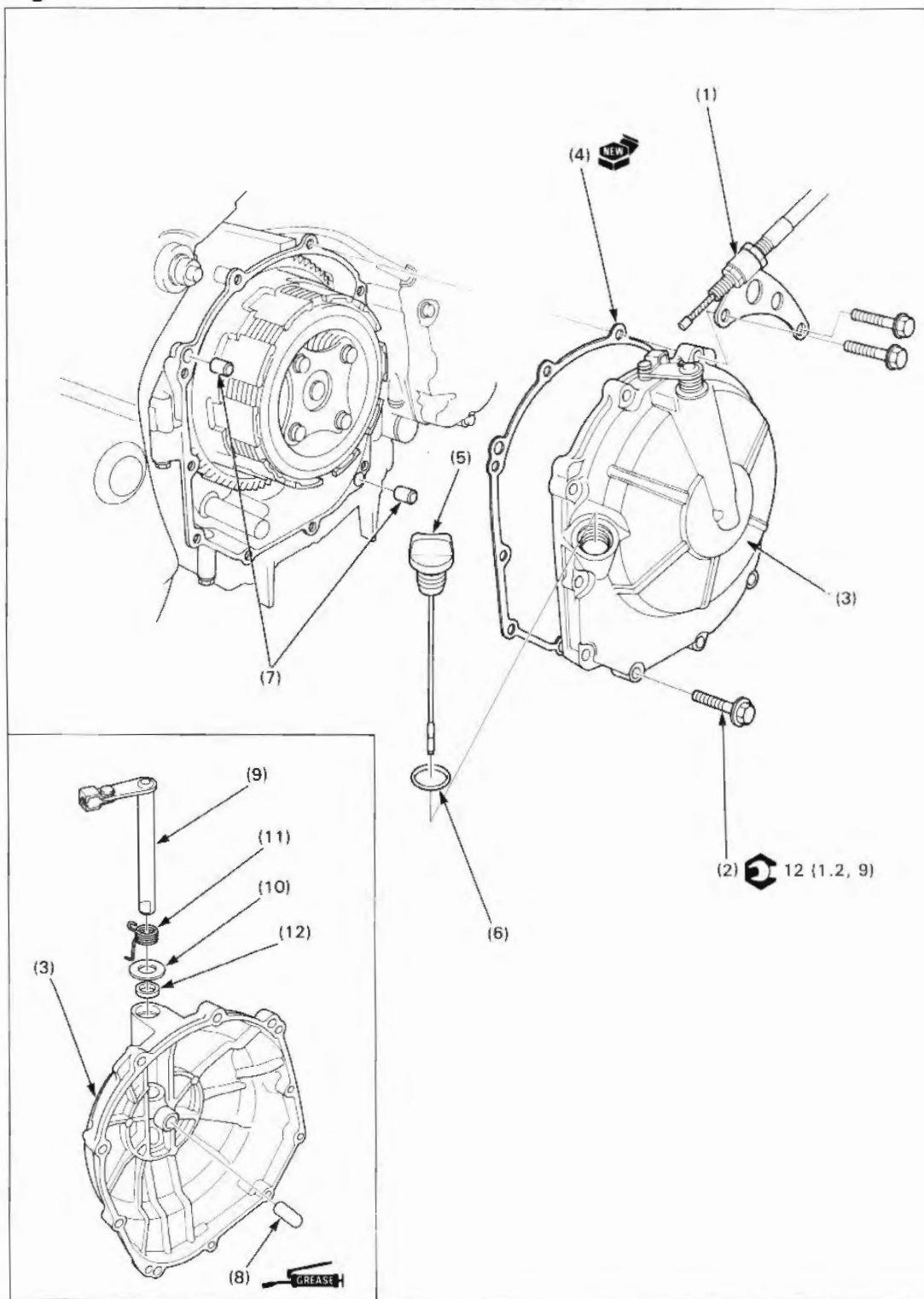

Requisite Service

- Side fairing removal/installation (page 2-3)
- Engine oil draining (drain bolt location: 3-3, draining procedure: section 2 of the Common Service Manual)

Procedure	Q'ty	Remarks
Removal Order		Installation is in the reverse order of removal.
(1) Clutch cable holder	1	
(2) Right crankcase cover bolt	8	Loosen the bolts in a crisscross pattern in several steps.
(3) Right crankcase cover	1	
(4) Gasket	1	
(5) Oil filler cap/Dip stick	1	
(6) O-ring	1	
(7) Dowel pin	2	
(8) Clutch lifter piece	1	
(9) Clutch lifter arm	1	
(10) Washer	1	
(11) Return spring	1	
(12) Oil seal	1	

Clutch Removal

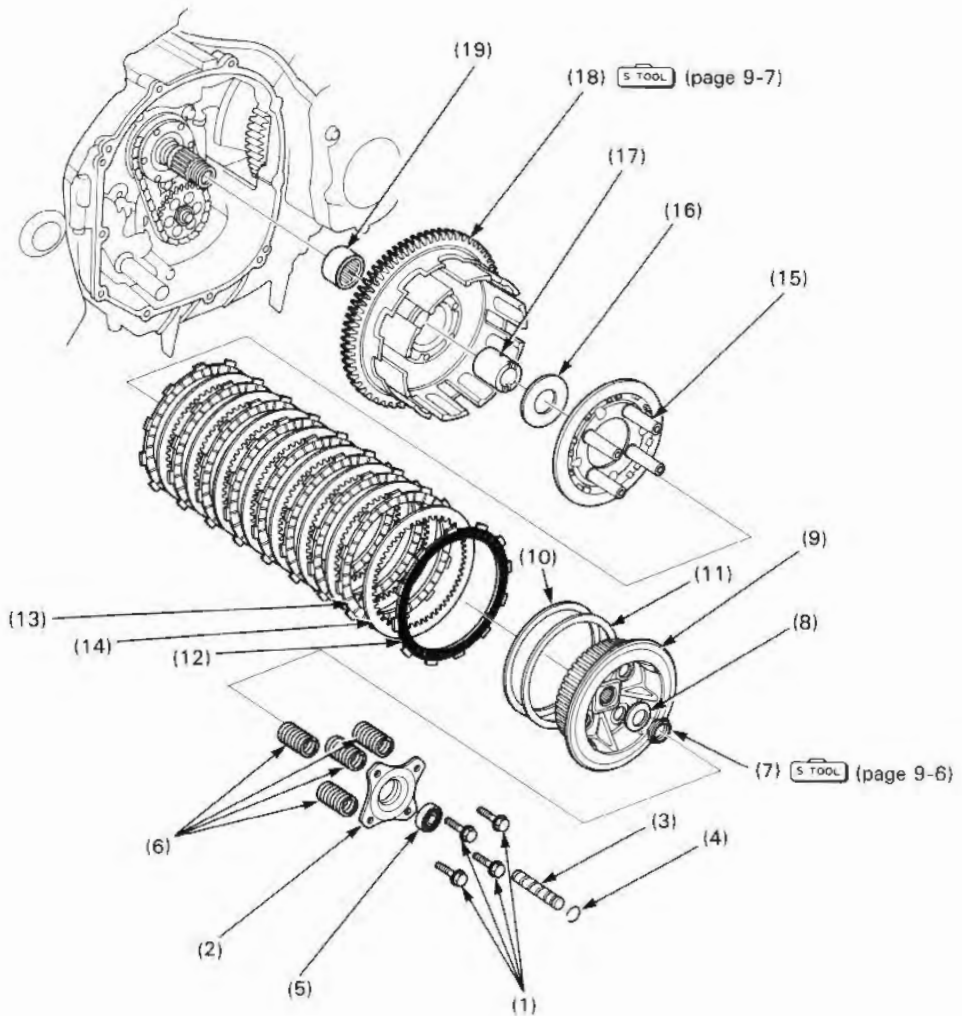

Requisite Service

- Right crankcase cover removal (page 9-2)

Procedure	Q'ty	Remarks
(1) Clutch lifter plate bolt	4	
(2) Clutch lifter plate	1	
(3) Clutch lifter rod	1	
(4) Stopper ring	1	
(5) Radial ball bearing (16001)	1	
(6) Clutch spring	1	
(7) Clutch center lock nut	1	Refer to page 9-6 for removal.
(8) Cone washer	1	
(9) Clutch center	1	
(10) Judder spring	1	
(11) Spring seat	1	
(12) Clutch disc (larger I.D.)	1	
(13) Clutch disc (smaller I.D.)	8	
(14) Clutch plate	8	
(15) Clutch pressure plate	1	
(16) Thrust washer	1	
(17) Clutch outer guide	1	Refer to page 9-6 for removal.
(18) Clutch outer	1	
(19) Needle bearing	1	Refer to page 9-7 for replacement.

Clutch Center Lock Nut Removal

Unstake the clutch center lock nut.
Set the clutch center holder to the pressure plate and loosely install the nuts.

S TOOL

Clutch center holder 07JMB-MN50300 or
07HGB-001000A (U.S.A. only)

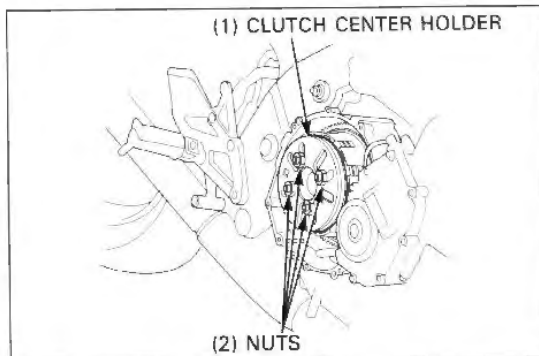

Remove the tool and tighten the nuts, then reattach the clutch center holder onto the bosses of the pressure plate.
Use at least two clutch lifter plate bolts to secure the tool onto the pressure plate.

Remove the clutch center lock nut.

S TOOL

Lock nut wrench, 17×27mm 07716-0020300 or
Extension bar 07716-0020500 □ or
equivalent commercially
available in U.S.A.

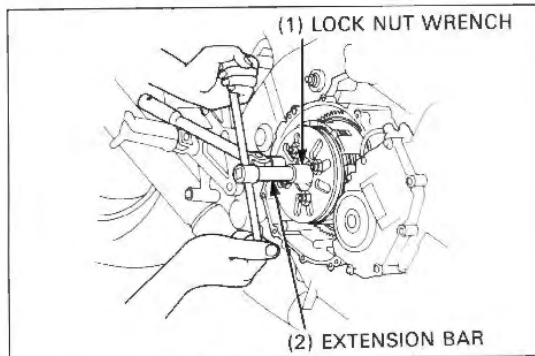
**Clutch Outer Removal**

Insert the 5mm pin into the holes in the primary driven gears to align the gear teeth.
Pull the clutch outer guide out by pinching the ribs on the clutch outer guide.

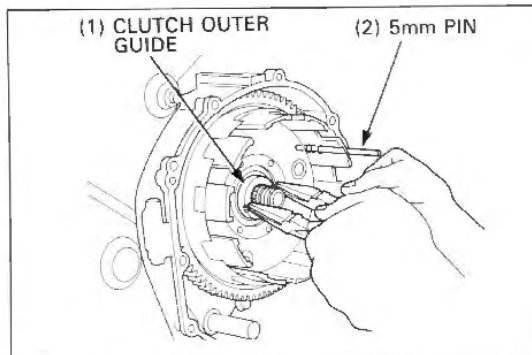

Align the projections of the crankcase with between the teeth of the primary driven gears and remove the clutch outer from the mainshaft.

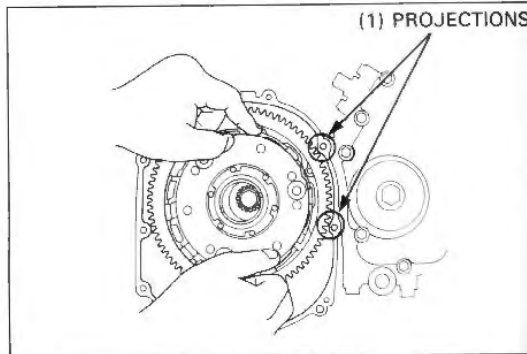

Clutch Outer Needle Bearing Replacement

Press the needle bearing out of the clutch outer.

S TOOL

Driver 07749-0010000
 Attachment, 32×35mm 07746-0010100
 Pilot, 30mm 07746-0040700

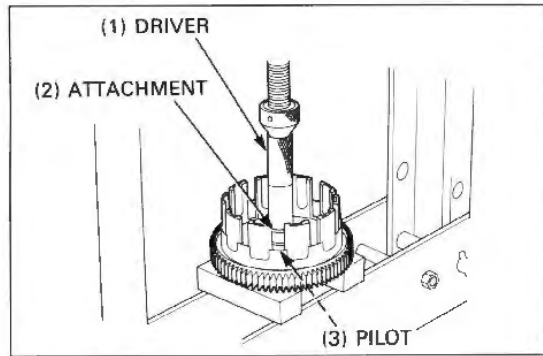

Press a new needle bearing into the clutch outer so that the edges of the needle bearing and clutch outer are flush.

S TOOL

Driver 07749-0010000
 Attachment, 32×35mm 07746-0010100
 Pilot, 30mm 07746-0040700

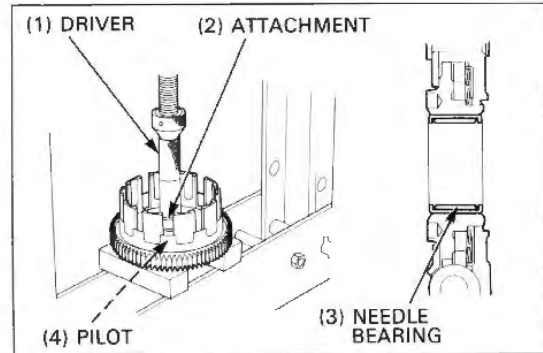

Gearshift Linkage Removal/Installation

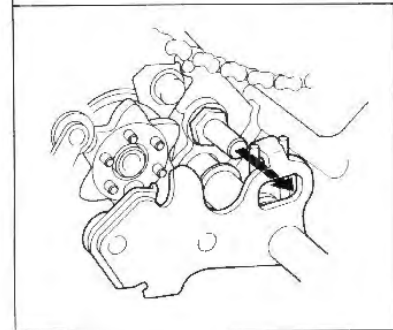
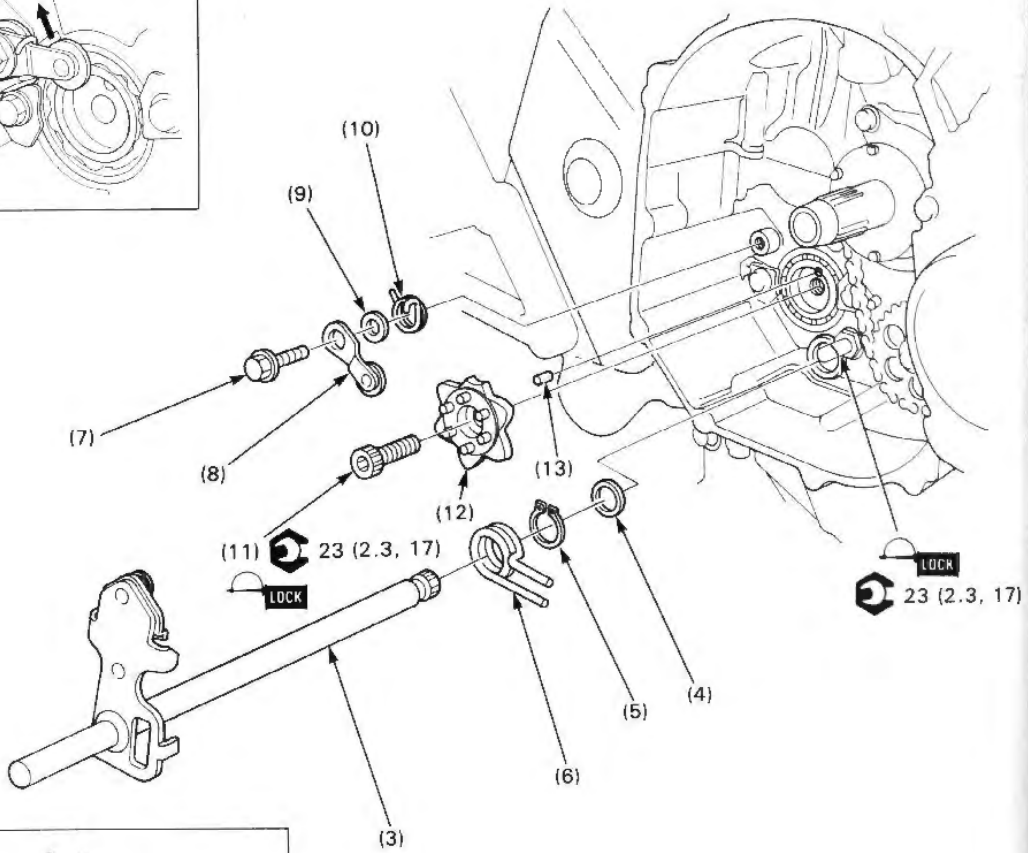
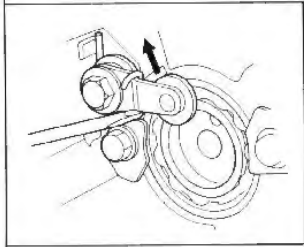
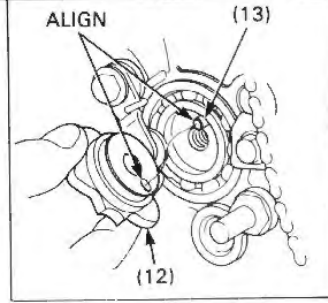
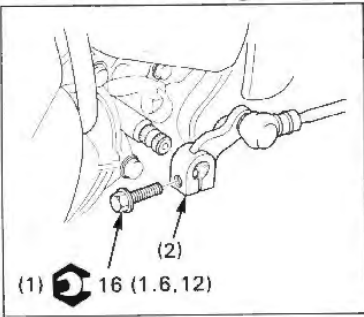

NOTE

- Make sure the gearshift linkage can be operated properly after assembly.

Requisite Service

- Clutch removal (page 9-4)
- Clutch installation (page 9-12)

Procedure		Q'ty	Remarks
	Removal Order		
(1)	Gearshift pedal pinch bolt	1	Installation is in the reverse order of removal.
(2)	Gearshift pedal link	1	When installing, align the punch marks on the gearshift pedal link and the gearshift spindle.
(3)	Gearshift spindle assembly	1	When installing, align the gear shift spindle return spring pin between the return spring ends.
(4)	Thrust washer	1	
(5)	Snap ring	1	Install the snap ring with the chamfered side facing the return spring.
(6)	Return spring	1	
(7)	Stopper arm bolt	1	
(8)	Stopper arm	1	
(9)	Washer	1	
(10)	Stopper arm spring	1	
(11)	Shifter cam center bolt	1	When loosening, be careful not to break the bolt because a locking agent is applied to the bolt threads.
(12)	Shifter cam	1	When installing, align the hole in the cam with the dowel pin.
(13)	Down pin	1	

Shift Drum/Shift Forks Removal/Installation

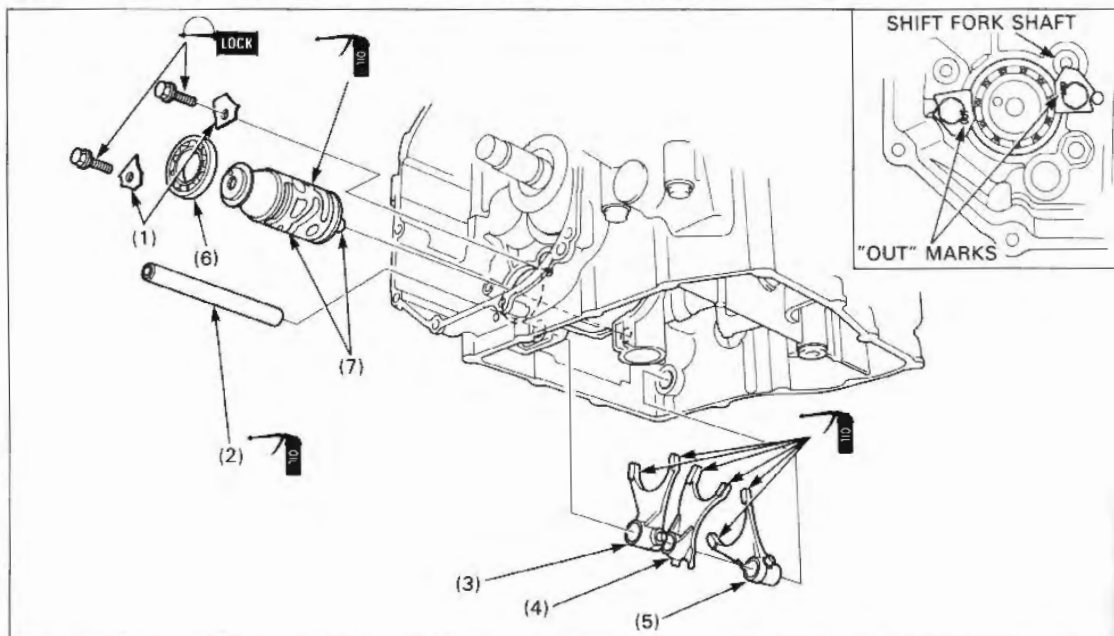

Requisite Service

- Gearshift linkage removal/installation (page 9-8)
- Oil pan removal (page 4-3)

Procedure	Q'ty	Remarks
Removal Order		Installation is in the reverse order of removal.
(1) Shift drum bearing set plate	2	NOTE • Install the set plates with the "OUT" mark facing out. • Install the set plate near the shift fork shaft so it holds the shaft in place as shown.
(2) Shift fork shaft	1	
(3) Right shift fork	1	Refer to page 9-11 for installation.
(4) Center shift fork	1	
(5) Left shift fork	1	
(6) Shift drum bearing	1	
(7) Shift drum	1	

Shift Fork Installation

Each shift fork has an identification mark; "R" is for the right shift fork, "L" is for the left shift fork and "C" is for the center shift fork.

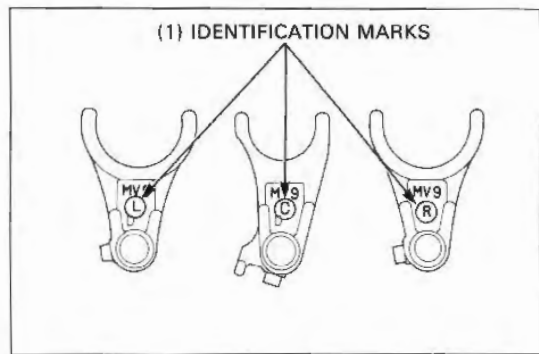

Apply molybdenum disulfide oil (a 50/50 mixture of engine oil and molybdenum disulfide grease) to the M3/4, C5 and C6 gear shift fork grooves.

Install the shift forks aligning the shift drum pins with the shift drum grooves with the identification marks facing the right side of the engine.

Apply clean engine oil to the shift fork shaft and install it through the shift forks.

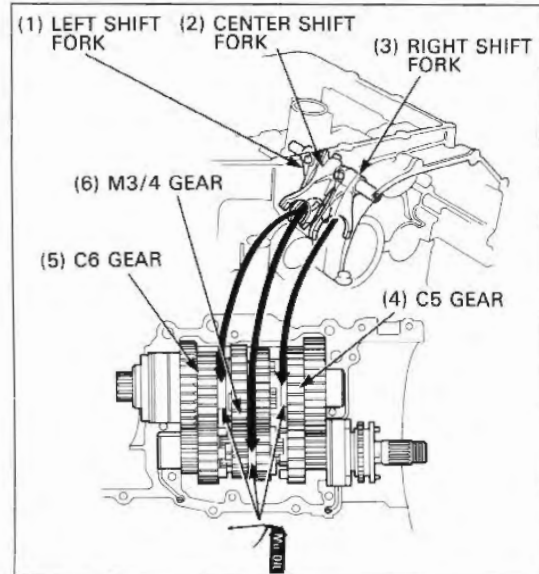

Clutch Installation

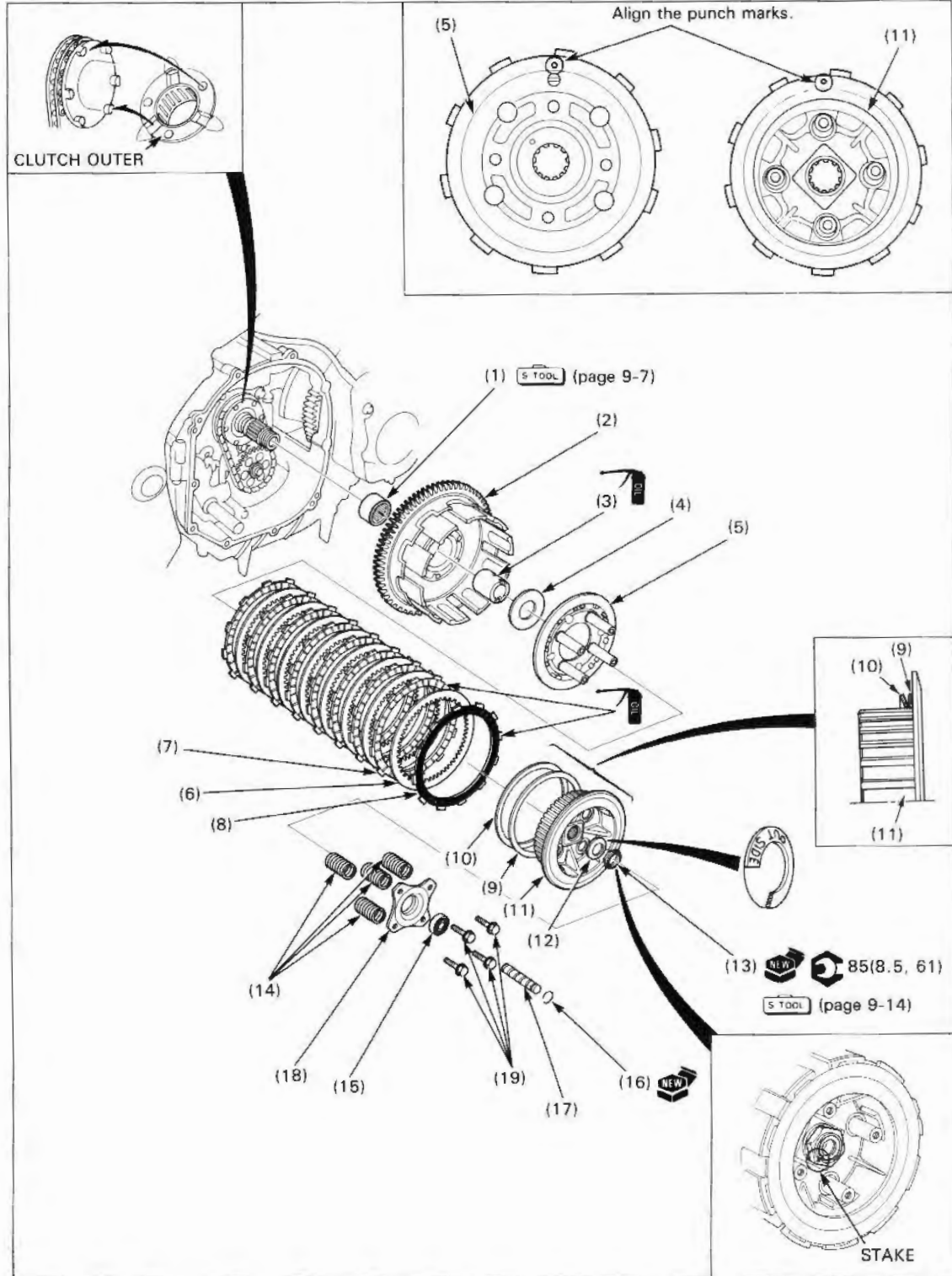

Requisite Service

- Right crankcase cover installation (page 9-2)

Procedure		Q'ty	Remarks
(1)	Needle bearing	1	Refer to page 9-6 for replacement.
(2)	Clutch outer	1	Refer to page 9-14 for installation.
(3)	Clutch outer guide	1	
(4)	Thrust washer	1	
(5)	Clutch pressure plate	1	NOTE • Align the punch marks on the clutch center and clutch pressure plate.
(6)	Clutch plate	8	
(7)	Clutch disc (small I.D.)	8	
(8)	Clutch disc (large I.D.)	1	
(9)	Spring seat	1	
(10)	Judder spring	1	
(11)	Clutch center	1	
(12)	Cone washer	1	NOTE • Install the cone washer with the "OUT SIDE" mark facing out.
(13)	Clutch center lock nut	1	Refer to page 9-14 for installation.
(14)	Clutch spring	4	
(15)	Radial ball bearing (16001)	1	
(16)	Stopper ring	1	
(17)	Clutch lifter rod	1	Refer to page 9-15 for installation.
(18)	Clutch lifter plate	1	
(19)	Clutch lifter plate bolt	4	

Clutch Outer Installation

Install the clutch outer onto the mainshaft by aligning the projections of the crankcase between the teeth of the primary driven gears.

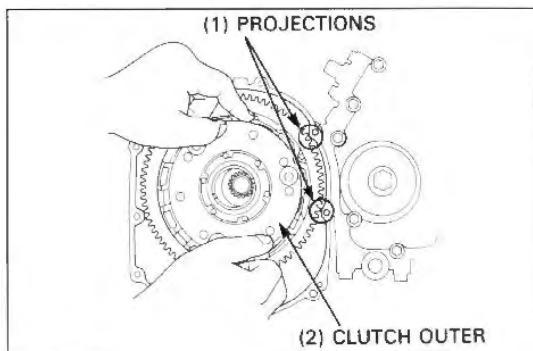

Install the clutch outer guide with the ribbed side facing out.

Install the clutch outer, aligning the clutch outer holes with the oil pump drive sprocket bosses by rotating the oil pump driven sprocket while holding the clutch outer and pushing in on it lightly.

After installing the clutch outer guide, remove the 5mm pin from the primary driven gears.

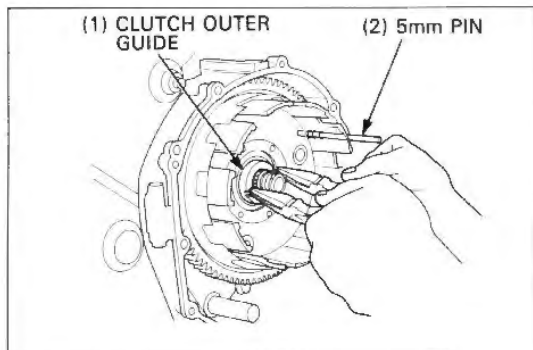

Clutch Center Lock Nut Installation

Set the clutch center holder to the pressure plate and loosely install the nuts.

 TOOL

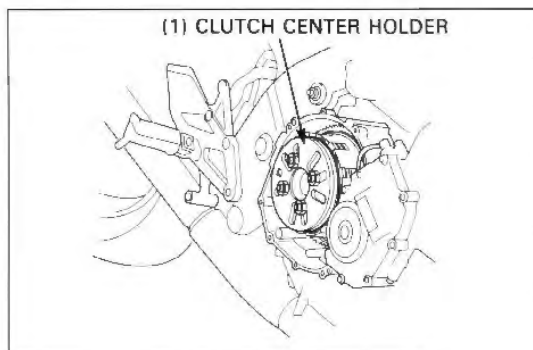

Clutch center holder 07JMB-MN50300 or
07HGB-001000A (U.S.A. only)

Remove the tool and tighten the nuts, then reattach the clutch center holder onto the bosses of the pressure plate. Use at least two clutch lifter plate bolts to secure the tool onto the pressure plate.



Tighten the clutch center lock nut while holding the pressure plate with a clutch center holder.

 TOOL

Lock nut wrench, 17×27mm 07716-0020300  or
Extension bar 07716-0020500 
equivalent commercially
available in U.S.A.

Torque: 85N·m (8.5kg·m, 61ft·lb)

Stake the lock nut as shown.

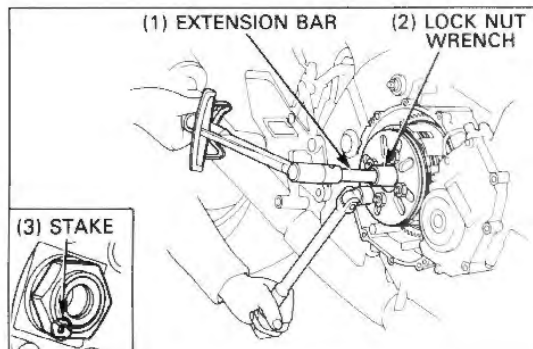

Clutch Lifter Rod Installation

Assemble the clutch lifter rod, stopper ring and clutch lifter plate, and install the assembly to the clutch pressure plate.

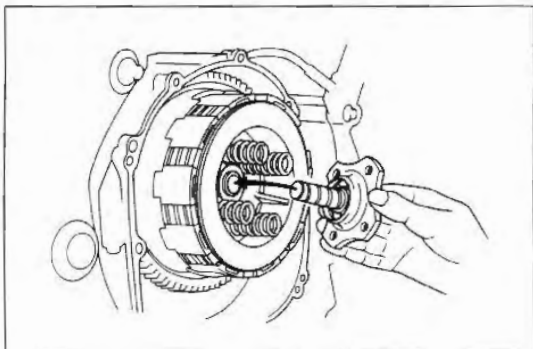

Secure the lifter plate by tightening the bolts in crisscross pattern in several steps.

NOTE

- If the clutch lifter rod comes out while tightening the clutch lifter plate bolts, push the rod all the way in to prevent the rod from being excentric.

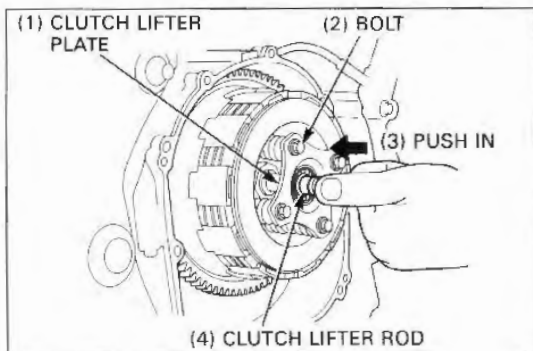

10. Crankcase/Cylinder/Piston

Service Information	10-1	Piston/Connecting Rod Removal/	
Troubleshooting	10-1	Installation	10-4
Crankcase Separation	10-2	Crankcase Assembly	10-6

Service Information

- The crankcase must be separated to repair the piston or connecting rod.
- Remove the following parts before separating the crankcase.
 - Engine (section 7)
 - Water pump (section 6)
 - Cylinder head (section 8)
 - Clutch and gearshift linkage (section 9)
 - Flywheel (section 15)
 - Ignition pulse generator rotor cover (section 15)
 - Starter motor and starter clutch (section 17)
- Take care not to damage the cylinder walls and pistons.
- Store the piston components in the same order they were removed so they can be reinstalled in their original locations.
- Before assembling the crankcase halves, apply sealant on the mating surfaces, wipe off excess sealant thoroughly.
- Mark and store the connecting rod bearings to be sure of their correct locations. If the connecting rod bearings are improperly installed they will block the oil holes, causing insufficient lubrication and eventual engine seizure.

Troubleshooting

Rough Idle

- Low cylinder compression

Low Compression

- Worn, stuck or broken piston rings
- Worn or damaged cylinder and piston

Compression Too High

- Excessive carbon build-up on piston top or combustion chamber

Excessive Smoke

- Worn cylinder piston or piston rings
- Improper installation of piston rings
- Scored or scratched piston or cylinder wall

Abnormal Noise (Piston)

- Worn piston pin or piston pin hole
- Worn connecting rod bearings
- Bent connecting rod
- Worn crankshaft main bearings

Crankcase Separation

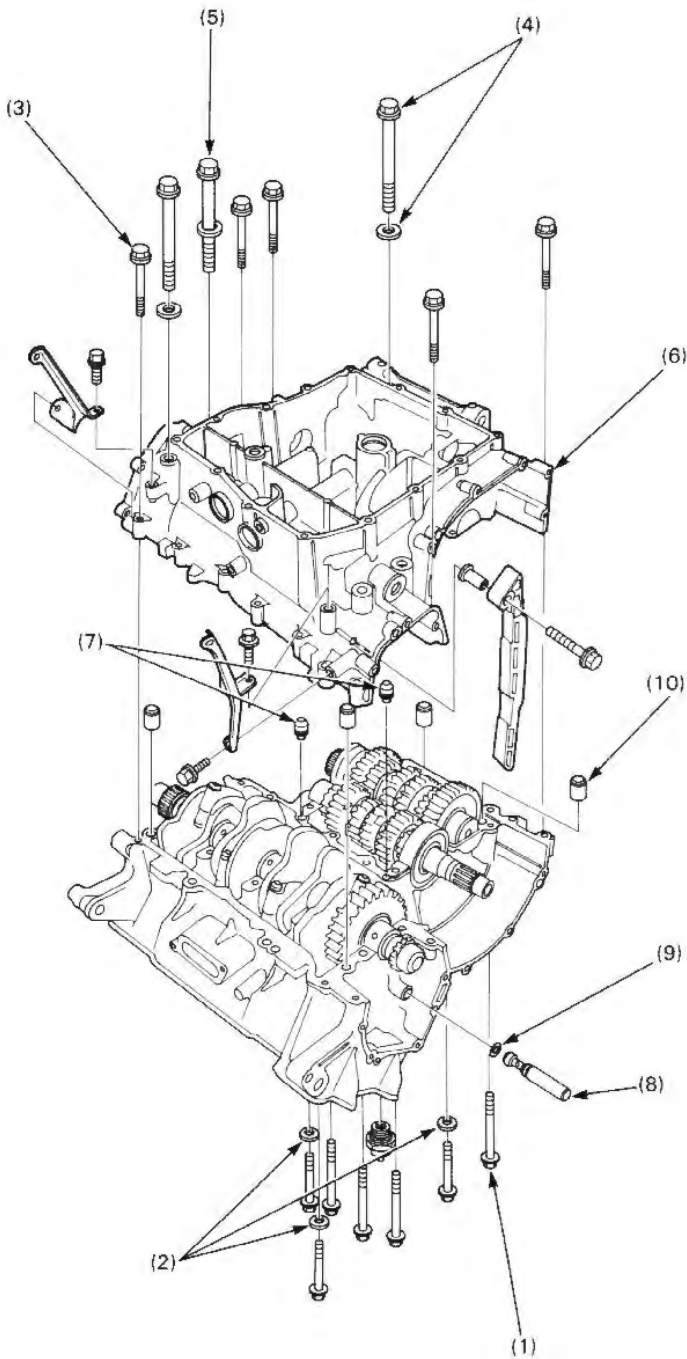

NOTE

- Refer to page 10-1 for the parts that is necessary to be removed for crankcase separation.

Procedure	Q'ty	Remarks
(1) Upper crankcase bolt (6 mm)	7	
(2) Sealing washer	3	
(3) Lower crankcase bolt(6 mm)	14	
(4) Lower crankcase bolt(10mm)	1	
(5) Lower crankcase bolt(8 mm)/sealing washer	10/10	From the outside to inside, loosen the bolts in a crisscross pattern in several steps.
(6) Lower crankcase	1	Clean the liquid sealant residue off the crankcase mating surfaces.
(7) Oil orifice(short)	2	
(8) Oil orifice(long)	1	
(9) O-ring	1	
(10) Dowel pin	4	

Piston/Connecting Rod Removal/Installation

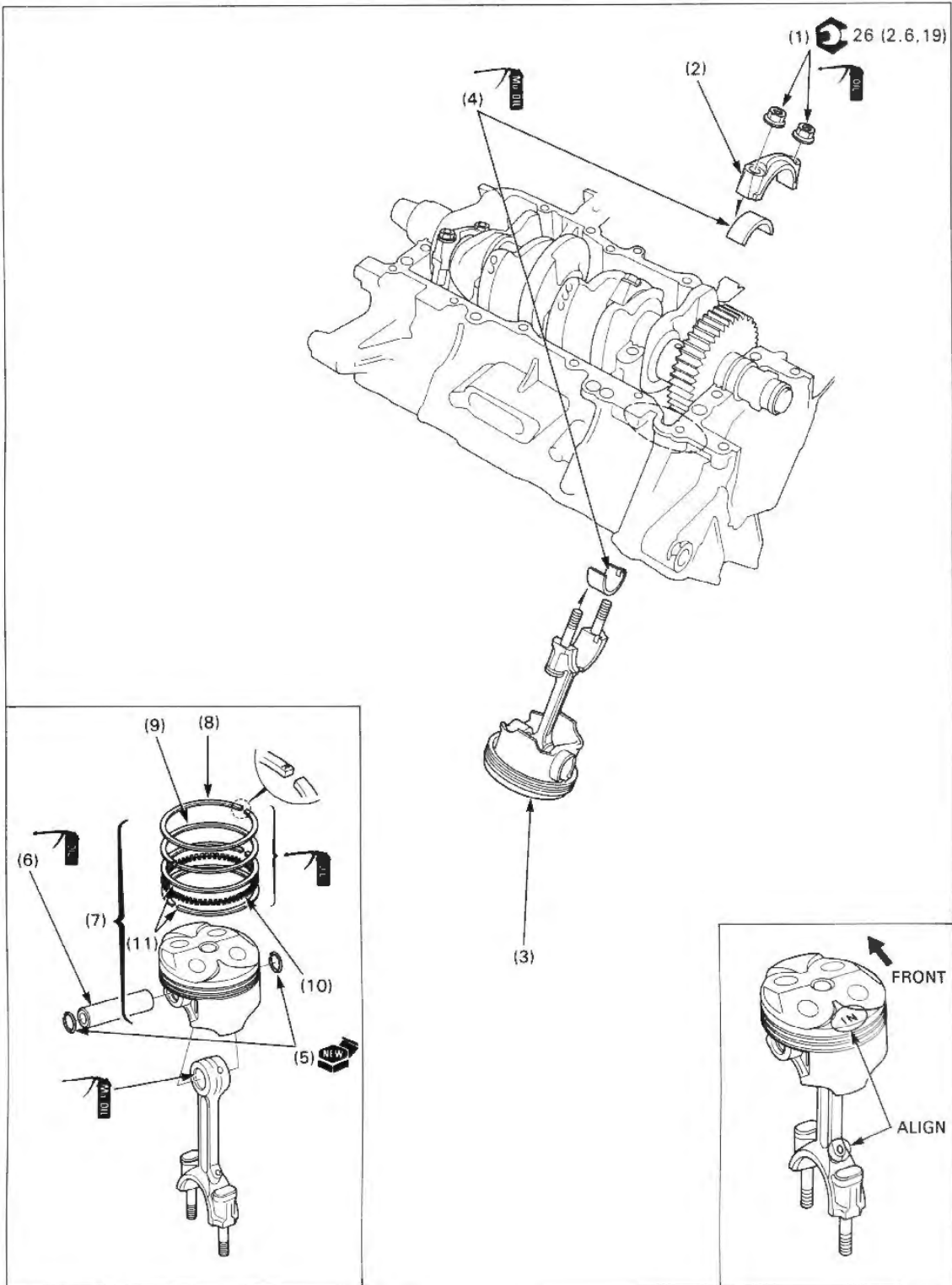

NOTE

- When disassembling, mark and store the disassembled parts to ensure that they are reinstalled in their original locations.
- Determine the replacement bearing color code according to the connecting rod bearing selection table (page 11-5).
- At installation, apply molybdenum oil to the connecting rod bearing surface.

Requisite Service

- Crankcase separation (page 10-2)
- Crankcase assembly (page 10-6)

Procedure	Q'ty	Remarks
Removal Order		Installation is in the reverse order of removal.
(1) Connecting rod bearing cap nut	8	NOTE <ul style="list-style-type: none"> • Before tightening, apply engine oil to the threads and seating surface of the nut. • Tighten the nuts gradually and alternately.
(2) Connecting rod bearing cap	4	When installing the bearing cap, be careful not to install it opposite its original position.
(3) Connecting rod/piston assembly	4	CAUTION <ul style="list-style-type: none"> • Do not try to remove the connecting rod/piston assembly from the bottom of the cylinder; the assembly will be locked so that the oil ring expands in the gap between the cylinder liner and the upper crankcase.
(4) Connecting rod bearing	8	Install the connecting rod/piston assembly with the oil hole in the connecting rod facing the intake side. When installing, align the oil holes in the bearing and the connecting rod, and the bearing tabs with the grooves in the connecting rod and bearing cap.
(5) Piston pin clip	8	
(6) Piston pin	4	
(7) Piston assembly	4	Install the piston on the connecting rod with the "IN" mark on the piston head facing the oil hole side (intake side).
(8) Top ring	4	Install the piston rings with the mark ("T" or "R") facing up.
(9) Second ring	4	Install the piston rings with the mark ("T" or "RN") facing up.
(10) Spacer	4	
(11) Oil ring	8	

Crankcase Assembly

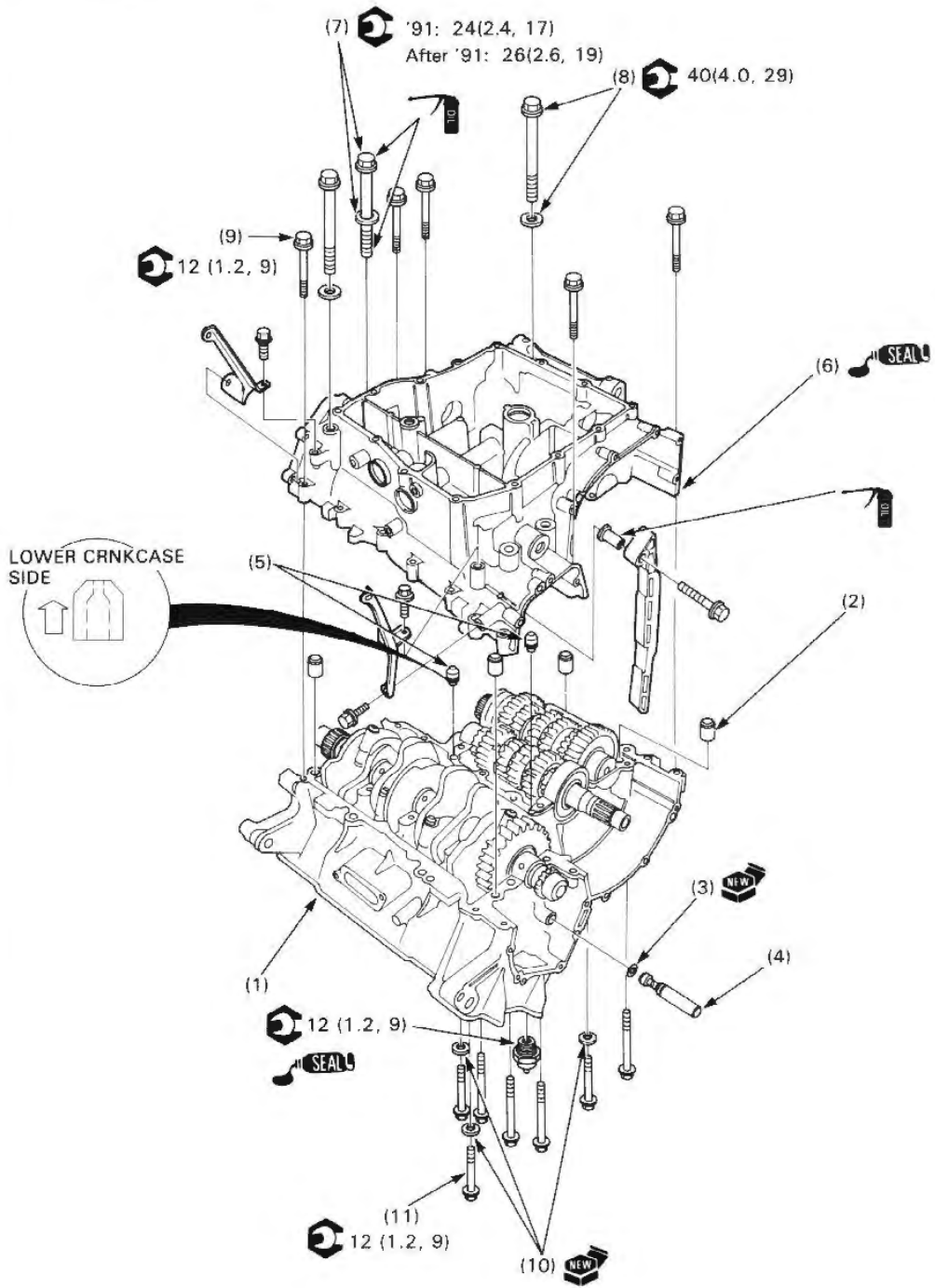

NOTE

- Refer to page 10-1 for the parts that is necessary to be installed after crankcase assembly.
- Refer to page 10-8 for crankcase bolt location.

Procedure	Q'ty	Remarks
(1) Upper crankcase	1	CAUTION • Do not apply sealant around the oil passage area and main bearing journal area. Refer to the illustration on page 10-8 for applying are.
(2) Dowel pin	4	
(3) O-ring	1	
(4) Oil orifice(long)	1	
(5) Oil orifice(short)	2	CAUTION • Install the oil orifice with the smaller diameter side facing the lower crankcase.
(6) Lower crankcase	1	
(7) Lower crankcase bolt(8 mm)/sealing washer	10/10	From the inside to outside, tighten the bolts in a crisscross pattern in several steps.
(8) Lower crankcase bolt(10mm)	1	
(9) Lower crankcase bolt(6 mm)	14	
(10) Sealing washer	3	Install the sealing washer to the bolt indicated by the "Δ" mark. Refer to page 10-8.
(11) Upper crankcase bolt(6 mm)	7	

Liquid Sealant Application

Apply a light but thorough coating of sealant to the crankcase mating surface except to the main bearing journal bolt (8mm lower crankcase bolt) areas and the oil passage areas as shown.

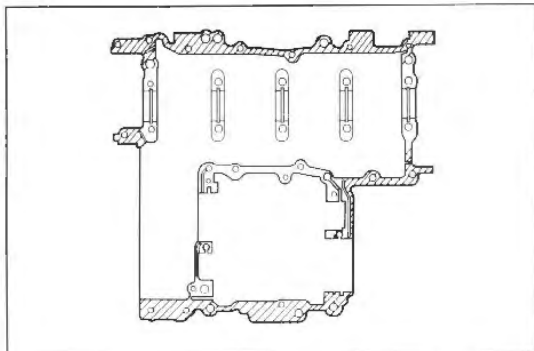
**Crankcase Bolt Location**

From the inside to outside, tighten the lower crankcase bolts (8 mm) crisscross pattern in several steps.

Torque :

Crankcase bolt (8mm): 24 N · m (2.4kg-m, 17ft-lb)

Install the remaining crankcase bolts and sealing washers as shown.

NOTE

- Install the sealing washers to the bolt holes indicated by the "△" marks.

Tighten all the crankcase bolts in gradual, crisscross pattern, beginning with the larger diameter bolts first as shown.

Torque :

6 mm bolt : 12 N·m (1.2kg-m, 9 ft-lb)

10 mm bolt : 40 N·m (4.0 kg-m, 29 ft-lb)

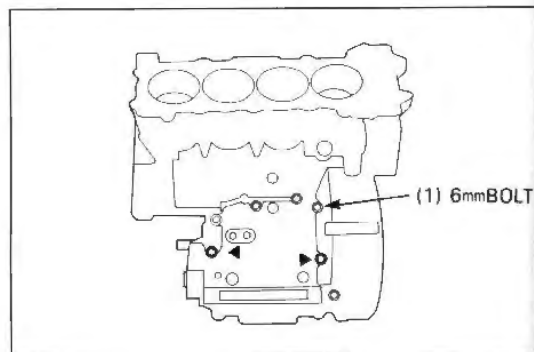
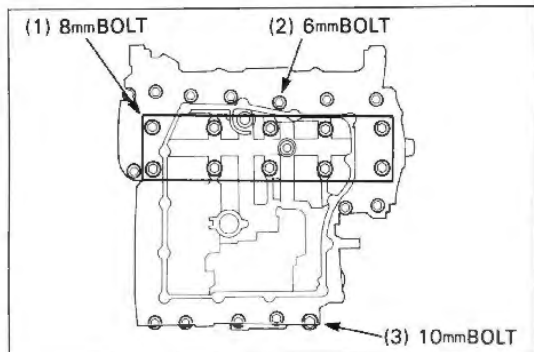

11. Crankshaft/Transmission

Service Information	11-1	Transmission Removal/Installation	11-6
Troubleshooting	11-1	Mainshaft Disassembly/Assembly	11-8
Crankshaft Removal/Installation	11-2	Countershaft Disassembly/Assembly	11-10
Crankshaft Bearing Replacement	11-4		

Service Information

- The crankcase must be separated to repair the transmission or crankshaft.
- During crankshaft removal and installation, do not damage the crankshaft main journal bearings.
- All bearing inserts are select fitted and are identified by color code. Select replacement bearings from the code tables.
- After installing new bearings, recheck them with plastigauge to verify clearance.
- Apply molybdenum disulfide oil to the main journals and crankpins during assembly.

Troubleshooting

Crankshaft Noisy

- Worn crankshaft main journal bearings
- Worn connecting rod bearings
- Bent connecting rod

Hard To Shift

- Improper clutch adjustment
- Incorrect engine oil viscosity
- Improper clutch operation
- Bent shift forks
- Bent shift fork shaft
- Bent shift fork claw
- Damaged shift drum cam grooves
- Bent shift spindle

Transmission Jumps Out Of Slots

- Worn gear engagement dogs or slots
- Bent shift fork shaft
- Damaged shift drum stopper arm
- Damaged or bent shift fork
- Broken shift linkage return spring
- Damaged shift drum cam grooves

Crankshaft Removal/Installation

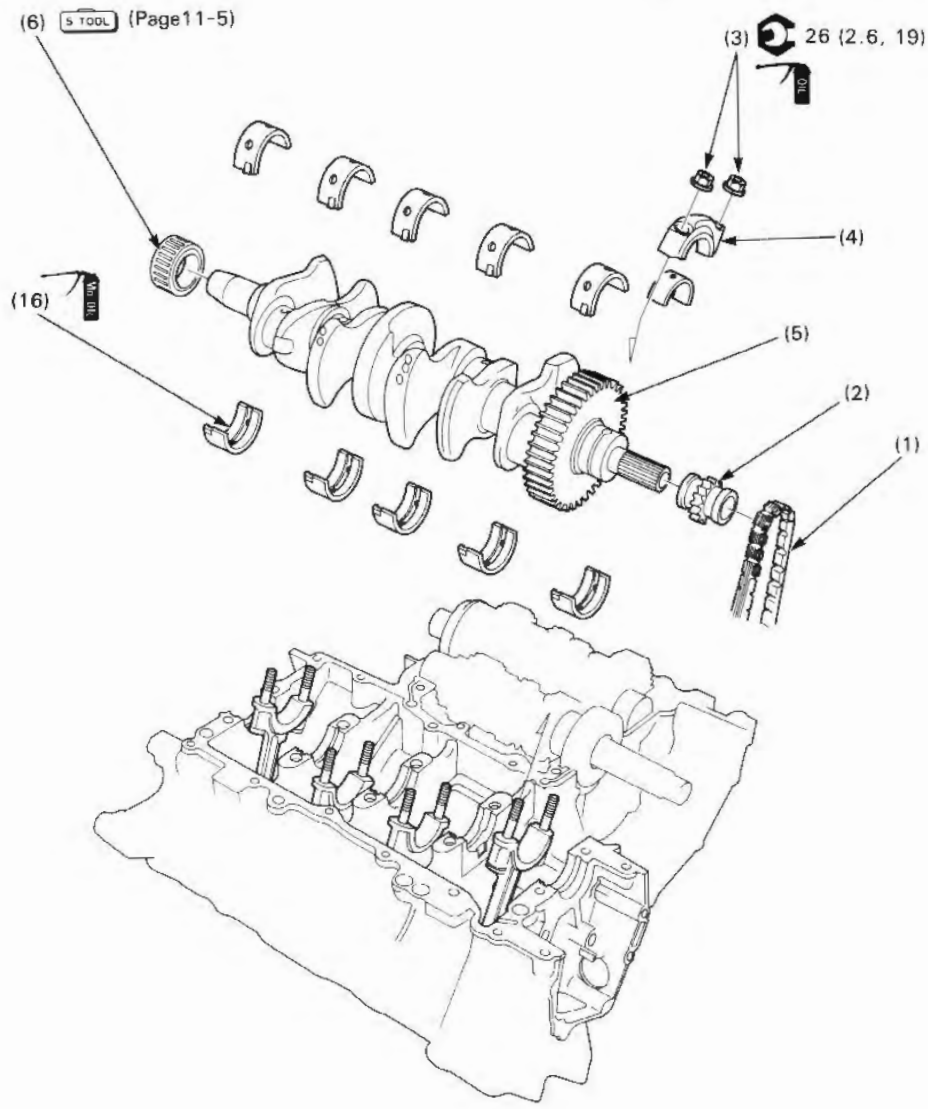
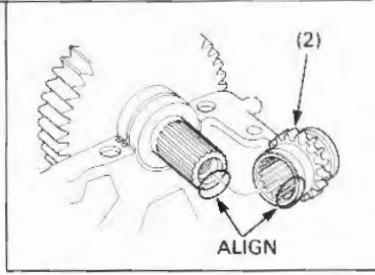

NOTE

- While disassembling, mark and store the disassembled parts to ensure that they are reinstalled in their original locations.
- Determine the replacement bearing color code according to the main journal bearing selection table (page 11-4).
- At installation, apply molybdenum oil to the main journal bearing surface.

Requisite Service

• Crankcase separation (page 10-2)

• Crankcase assembly (page 10-6)

Procedure	Q'ty	Remarks
Removal Order		
(1) Cam chain	1	
(2) Timing sprocket	1	
(3) Connecting rod bearing cap nut	8	
(4) Connecting rod bearing cap	4	
(5) Crankshaft	1	
(6) Starter clutch needle bearing	1	Refer to page 11-5 for removal.
(7) Crankshaft main journal bearing	10	
Installation Order		
(7) Crankshaft main journal bearing	10	Refer to page 11-5 for installation.
(6) Starter clutch needle bearing	1	
(5) Crankshaft	1	Before installing the crankshaft, position all the pistons at Top Dead Center (TDC) to prevent the crankshaft main journals from being damaged with the connecting rod bolts.
(4) Connecting rod bearing cap	4	When installing the bearing cap, be careful not to install it opposite its original position.
(3) Connecting rod bearing cap nut	8	NOTE
		• Before tightening, apply engine oil to the threads and seating surface of the nut.
		• Tighten the nuts gradually and alternately.
(2) Timing sprocket	1	Install the cam sprocket aligning the extra wide teeth of the crankshaft and sprocket.
(1) Cam chain	1	

Crankshaft Bearing Replacement

Main Journal Bearing Selection

Record the crankcase I.D. code letters stamped on the left side of the upper crankcase.

NOTE

- Letters (A, B or C) on the upper crankcase are the codes for the main journal I.D.s from the left side.

(1) I.D. CODE LETTERS

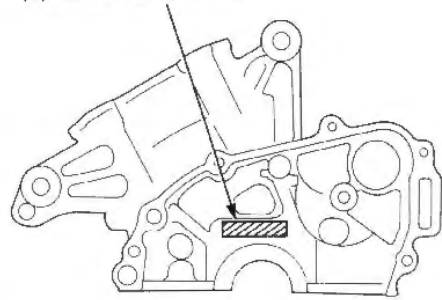

Record the corresponding main journal O.D. code numbers from the crank weight.

NOTE

- Numbers (1 or 2) on the crank weight are the codes for the main journal O.D.s from the left.

Cross reference the case and journal codes to determine the replacement bearing color code.

	Crankcase I.D. code	A	B	C
		Main journal O.D. code	36.000-36.008 mm (1.4173-1.4176 in)	36.008-36.016 mm (1.4176-1.4180 in)
1	32.992-33.000 mm (1.2989-1.2992 in)	D (Pink)	C (Yellow)	B (Green)
2	32.984-32.992 mm (1.2986-1.2989 in)	C (Yellow)	B (Green)	A (Brown)

A : Brown : 1.492-1.496 mm (0.0587-0.0589 in)

B : Green : 1.488-1.492 mm (0.0586-0.0587 in)

C : Yellow : 1.484-1.488 mm (0.0584-0.0586 in)

D : Pink : 1.480-1.484 mm (0.0583-0.0584 in)

(1) MAIN JOURNAL O.D. CODE NUMBERS



(1) MAIN JOURNAL BEARINGS

(2) COLOR CODE

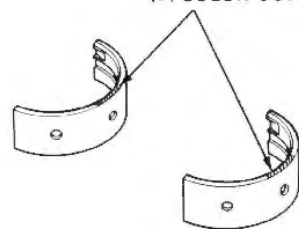

Connecting Rod Bearing Selection

Record the connecting rod I.D. code numbers on the rods.

NOTE

- Numbers (1 or 2) on the connecting rods are the codes for the connecting rod I.D.s.

(1) CONNECTING ROD I.D. CODE NUMBER

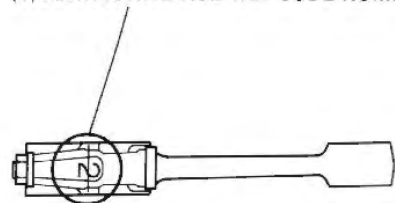

Record the crankpin O.D. code letters from the crank weight.

NOTE

- Letters (A or B) on the crank weight are the codes for the crankpin O.D.s from the left side.

Cross reference the crankpin and rod codes to determine the replacement bearing color code.

Connecting rod I.D. code		1	2
		Crankpin O.D. code	36.000-36.008 mm (1.4173-1.4176 in)
A	32.992-33.000 mm (1.2989-1.2992 in)	C (Yellow)	B (Green)
B	32.984-32.992 mm (1.2986-1.2989 in)	B (Green)	A (Brown)

- A : Brown : 1.494-1.498 mm (0.0588-0.0590 in)
- B : Green : 1.490-1.494 mm (0.0587-0.0588 in)
- C : Yellow : 1.486-1.490 mm (0.0585-0.0587 in)

Connecting Rod Selection

The weight code stamped on the connecting rod is an alphabetical code.

Be sure to use the connecting rods having the same weight code in an engine.

CAUTION

- If a connecting rod having the different weight code is to be used, be sure that the difference in weight (code) is held within a single weight rank.

Starter Clutch Needle Bearing Replacement

Remove the needle bearing with a commercially available universal bearing puller.

CAUTION

- To protect the crankshaft main journal from the bearing puller claws, cover the mainshaft journal properly; worn main journal bearings are usable as protectors.

Drive a new needle bearing onto the crankshaft.



Crankcase assembly collar 07964-MB00200

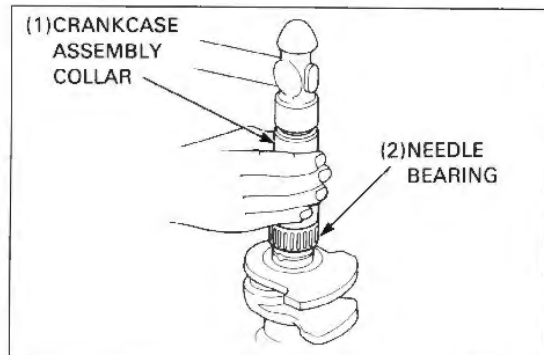
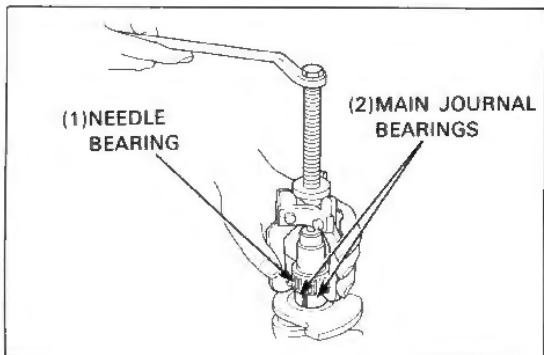
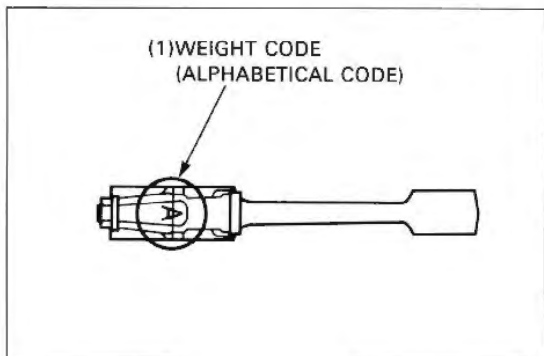
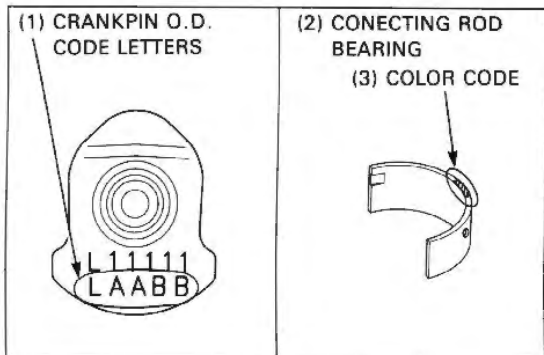

Transmission Removal/Installation

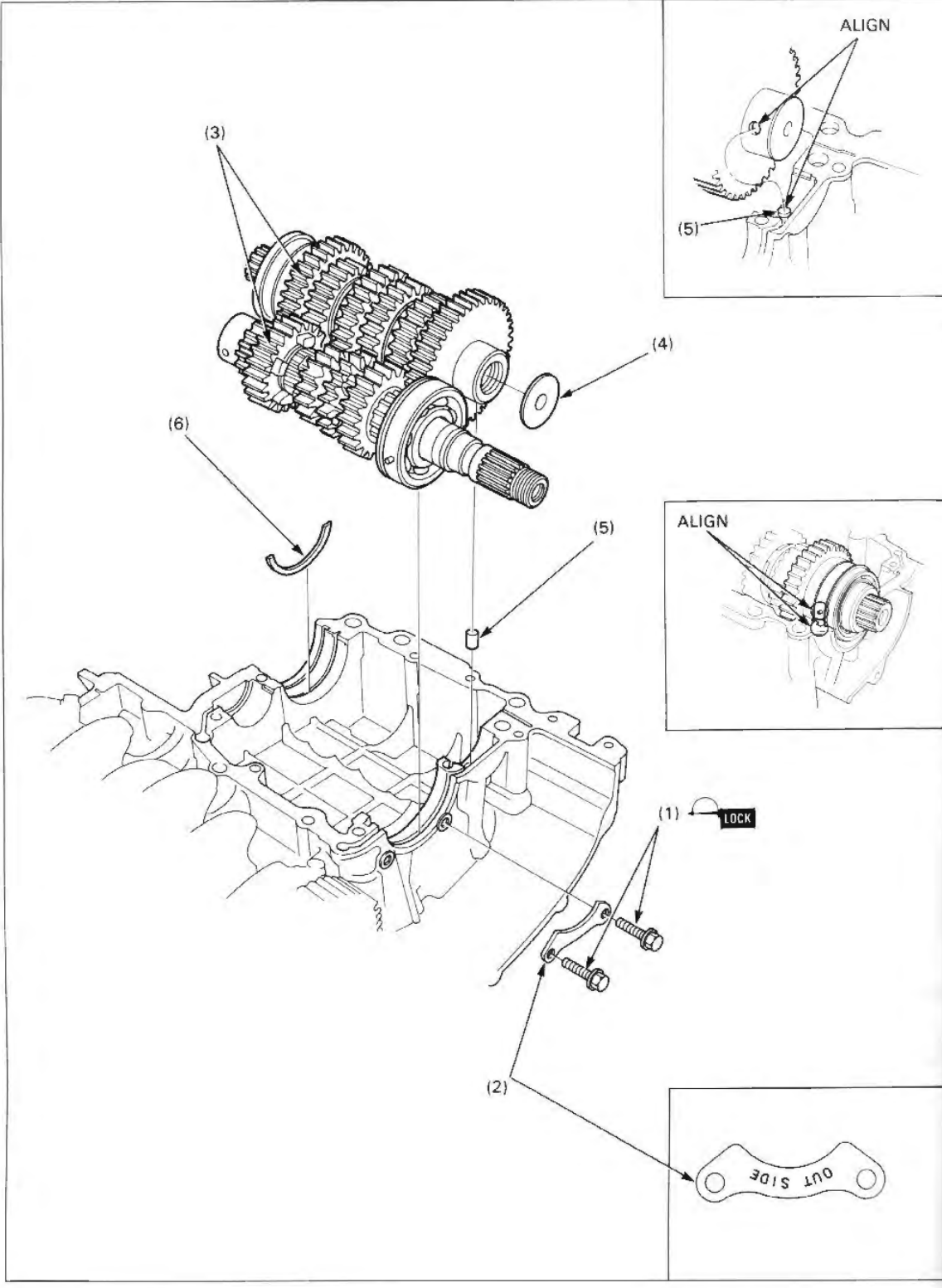

Requisite Service

- Crankcase separation(page 10-2)

- Crankcase assembly(page 10-6)

Procedure	Q'ty	Remarks
Removal Order		
(1) Countershaft bearing set plate bolt	2	
(2) Countershaft bearing set plate	1	
(3) Mainshaft/Countershaft assembly	1/1	
(4) Countershaft end plate	1	
(5) Dowel pin	1	
(6) Countershaft bearing stopper	1	
Installation Order		
(6) Countershaft bearing stopper	1	
(5) Dowel pin	1	
(4) Countershaft end plate	1	
(3) Mainshaft/Countershaft assembly	1/1	NOTE <ul style="list-style-type: none"> • Align the hole in the countershaft needle bearing case with the pin in the upper crankcase. • Align the groove in the countershaft bearing with the stopper, and pin on the bearing with the groove in the crankcase.
(2) Countershaft bearing set plate	1	Install the bearing set plate with the "OUT SIDE" mark facing out.
(1) Countershaft bearing set plate bolt	2	When installing, apply a locking agent to the threads of the bolts.

Mainshaft Disassembly/Assembly

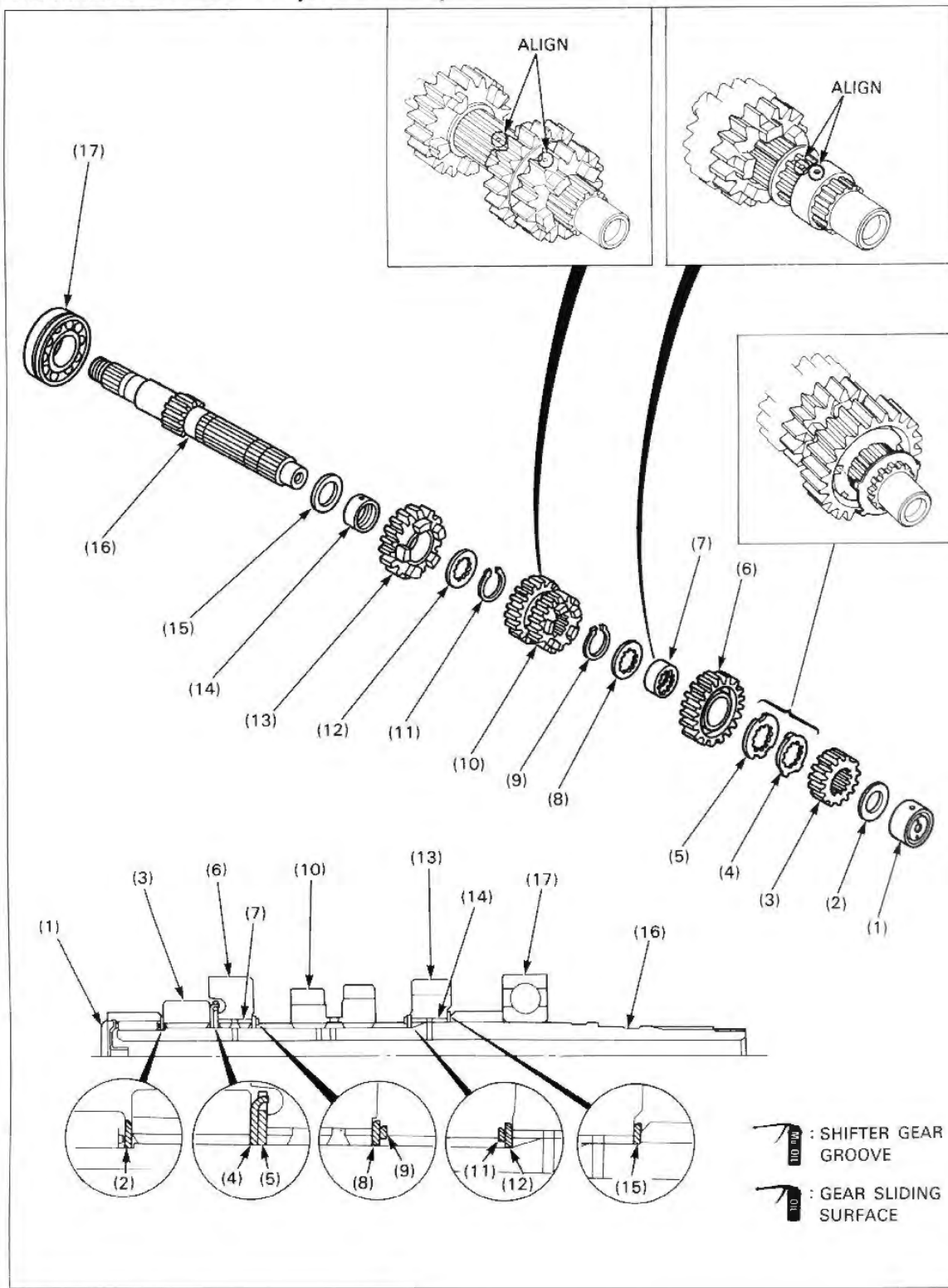

NOTE

- Apply molybdenum oil to the shifter gear grooves. Apply oil to all sliding surfaces of the mainshaft, countershaft and bushings.
- Install the thrust washer that contacts with the rotating gear with the chamfered side facing the rotating gear.
- Install the snap ring with the chamfered side facing the thrust load side.
- Install the spline bushing, aligning the oil holes in the bushing and the mainshaft.

Requisite Service

- Transmission removal/installation (page 11-6)

Procedure	Q'ty	Remarks
Disassembly Order		Assembly is in the reverse order of disassembly.
(1) Shaft end case	1	
(2) Washer	1	
(3) M2 gear (16T)	1	
(4) Lock washer	1	When installing, align the claws of the lock washer with the cutouts in the spline washer.
(5) Spline washer	1	
(6) M6 gear (23T)	1	
(7) M6 spline bushing	1	
(8) Spline washer	1	
(9) Snap ring	1	
(10) M3/M4 gear (17/19T)	1	NOTE • Install the M3/M4 gear aligning either oil hole in the M3/M4 gear and the mainshaft.
(11) Snap ring	1	
(12) Spline washer	1	
(13) M5 gear (20T)	1	
(14) M5 bushing	1	
(15) Thrust washer	1	
(16) Mainshaft /M1 gear (14T)	1	
(17) Mainshaft bearing (6305)	1	Refet to page 11-12 for replacement.

Countershaft Disassembly/Assembly

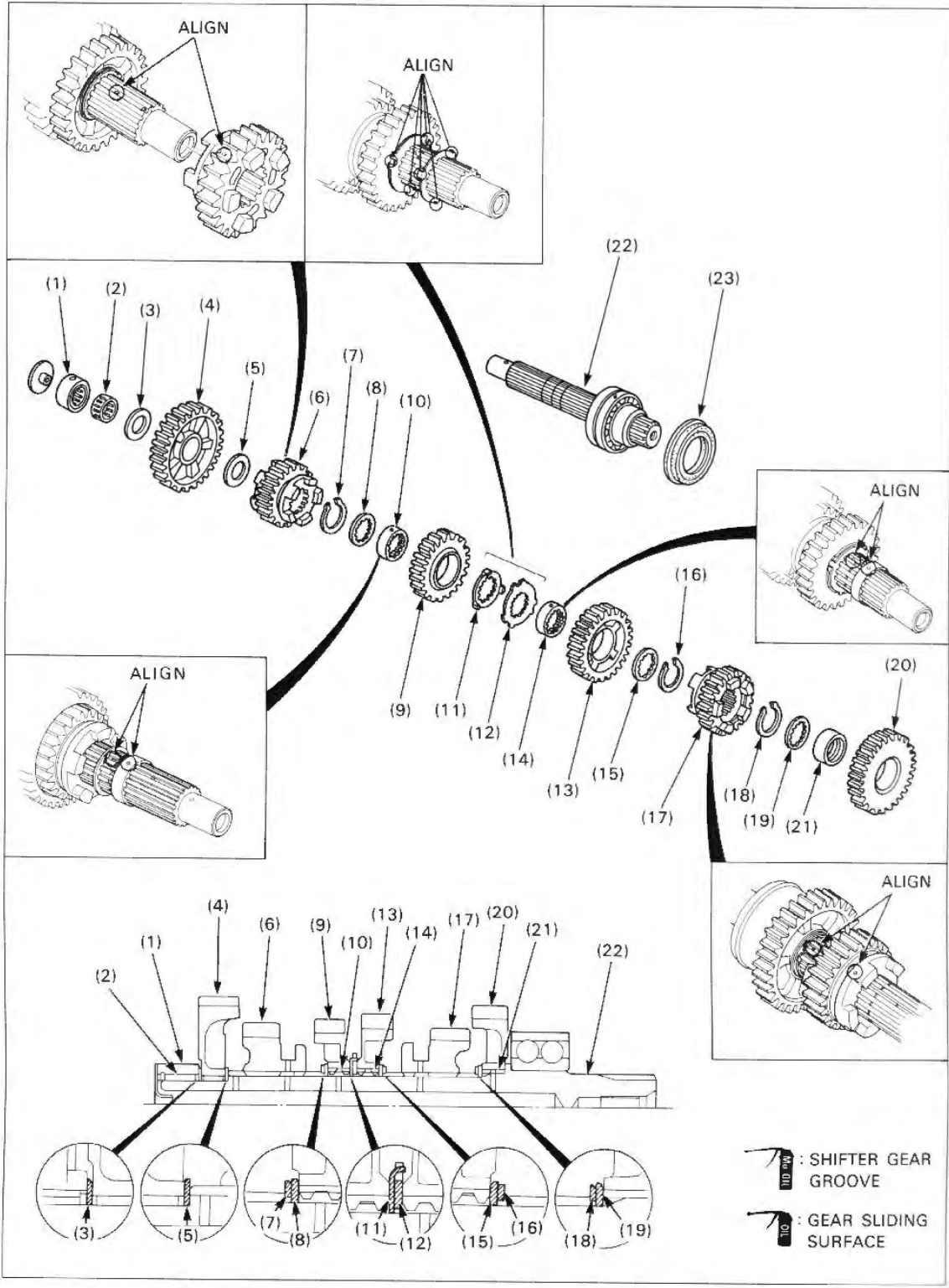

NOTE

- Apply molybdenum oil to the shifter gear grooves. Apply oil to all sliding surfaces of the mainshaft, countershaft and bushings.
- Install the thrust washer that contacts with the rotating gear with the chamfered side facing the rotating gear.
- Install the snap ring with the chamfered side facing the thrust load side.
- Install the spline bushing aligning the oil holes in the bushing and the countershaft.

Requisite Service

- Transmission removal/installation (page 11-6)

Procedure	Q'ty	Remarks
Disassembly Order		Assembly is in the reverse order of disassembly.
(1) Needle bearing case	1	
(2) Needle bearing	1	
(3) Thrust washer	1	
(4) C1 gear (41T)	1	
(5) Thrust washer	1	
(6) C5 gear (24T)	1	NOTE • Install the C5 gear, aligning either oil hole in the C5 gear and the countershaft.
(7) Snap ring	1	
(8) Spline washer	1	
(9) C4 gear (26T)	1	
(10) C4 gear spline bushing		
(11) Lock washer	1	When installing, align the claws of the lock washer with the cutouts in the spline washer.
(12) Spline washer	1	NOTE
(13) C3 gear (27T)	1	• Install the C3 gear, aligning either oil hole in the C3 gear and the countershaft.
(14) C3 gear bushing	1	
(15) Spline washer	1	
(16) Snap ring	1	
(17) C6 gear (25T)	1	NOTE • Install the C6 gear, aligning either oil hole in the C6 gear and the countershaft.
(18) Snap ring	1	
(19) Spline washer	1	
(20) C2 gear(33T)	1	
(21) C2 gear bushing	1	
(22) Countershaft	1	
(23) Countershaft oil seal	1	

Mainshaft Bearing Replacement

Remove the mainshaft bearing by pressing the mainshaft as shown.

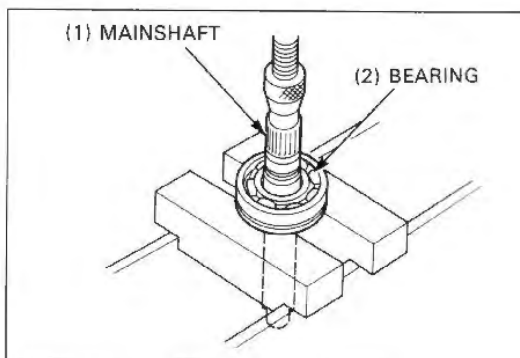

Install a new radial ball bearing onto the mainshaft using a press as shown.



Driver, 40mm I.D.
Attachment, 25mm I.D.

07746-0030100
07746-0030200

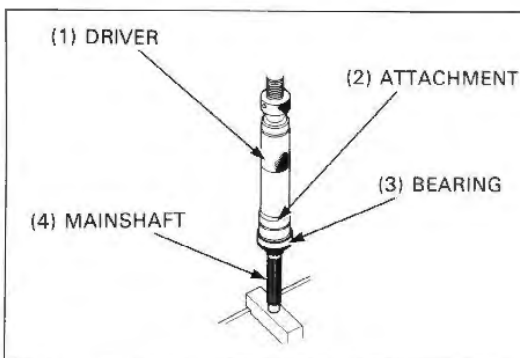

12. Front Wheel/Suspension/Steering

Service Information	12-1	Fork Removal/Installation	12-8
Troubleshooting	12-1	Fork Disassembly ('91-'93)	12-10
Right Handlebar Removal/Installation	12-2	Fork Disassembly (After '93)	12-12
Left Handlebar Removal/Installation	12-3	Fork Assembly ('91-'93)	12-14
Front Wheel Removal/Installation	12-4	Fork Assembly (After '93)	12-16
Front Wheel Disassembly/Assembly	12-6	Steering Stem Removal/Installation	12-18

Service Information

⚠ WARNING

- A contaminated brake disc or pad reduces stopping power. Discard contaminated pads and clean a contaminated disc with a high quality brake degreasing agent.

- Raise the front wheel off the ground by suspending the frame with a sling.
- Refer to section 14 for brake system information.
- Refer to section 16 of the Common Service Manual for tire removal/installation.
- Use only tires marked "TUBELESS" and tubeless valves on rims marked "TUBELESS TIRE APPLICABLE".

Troubleshooting

Hard Steering

- Faulty steering head bearings
- Damaged steering head bearings
- Insufficient tire pressure
- Steering head bearing adjustment nut too tight

Steers To One Side Or Does Not Track Straight

- Unevenly adjusted right and left shock absorbers
- Bent fork
- Bent axle: wheel installed incorrectly
- Faulty steering head bearings
- Bent frame
- Worn front wheel bearings
- Worn swingarm pivot bearing

Front Wheel Wobbling

- Bent rim
- Worn front wheel bearings
- Faulty tire
- Unbalanced tire and wheel

Wheel Turns Hard

- Faulty wheel bearing
- Brake drag
- Bent front axle

Soft Suspension

- Weak fork spring
- Insufficient fluid in fork
- Low fluid level in fork
- Low tire pressure

Hard Suspension

- Incorrect fluid weight
- Bent fork tubes
- Clogged fork fluid passage
- High tire pressure

Front Suspension Noise

- Insufficient fluid in fork
- Loose fork fasteners

Right Handlebar Removal /Installation

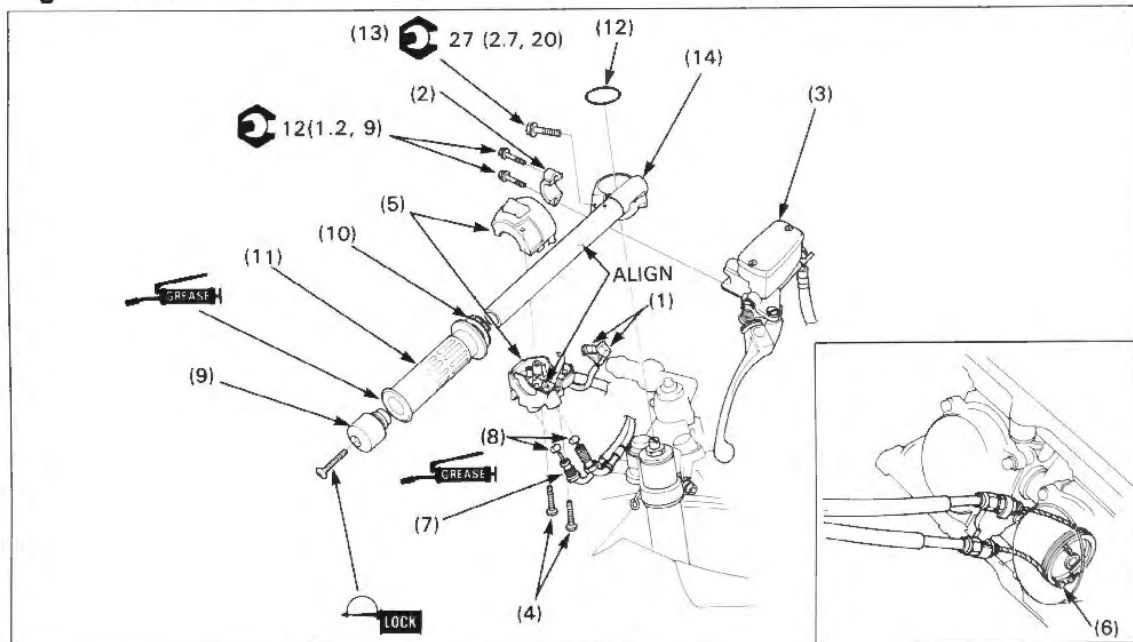

▲ WARNING

- Contaminants in the system may cause a reduction or loss of braking ability.

CAUTION

- Spilled brake fluid will damage painted, plastic or rubber parts.

Requisite Service

- Air cleaner housing removal/installation (page 6-3)
- Throttle grip free play adjustment(Refer to section 2 of the Common Service Manual.)

Procedure	Q'ty	Remarks
Removal Order		Installation is in the reverse order of removal.
(1) Front brakelight switch connector	2	
(2) Master cylinder holder	1	Align the holder mating surface with the punch mark on the handlebar and install the holder with the "UP" mark upward.
(3) Master cylinder assembly	1	
(4) Right handlebar switch housing screw	2	Tighten the front screw first then the rear one.
(5) Right handlebar switch housing	1	Align the tang of the housing with the hole in the handlebar.
(6) Throttle cable end(carburetor side)	1	
(7) Throttle cable nut	1	
(8) Throttle cable end(throttle pipe side)	2	Don't bend the cables too much.
(9) Handlebar weight	1	Align its boss with the inner weight.
(10) Throttle pipe	1	
(11) Throttle grip	1	Apply Honda Bond A or an equivalent to the inside surface of the grip.
(12) Stopper ring	1	
(13) Handlebar pinch bolt	1	Tighten the pinch bolt while pushing the handlebar forward.
(14) Right handlebar	1	Align the handlebar boss with the top bridge slot.

Left Handlebar Removal/Installation

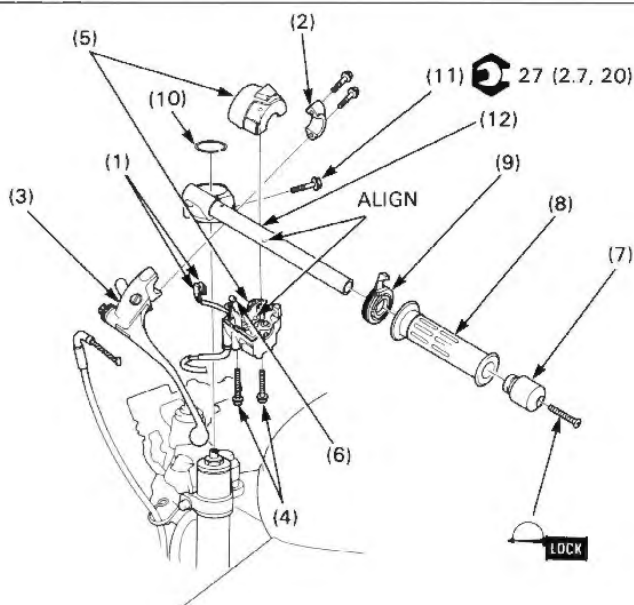

Procedure		Q'ty	Remarks
Removal Order			Installation is in the reverse order of removal.
(1)	Clutch switch connector	2	
(2)	Clutch lever holder	1	Align the holder mating surface with the punch mark on the handlebar and face the holder with the "UP" mark upward. Tighten the upper bolt first then the lower bolt.
(3)	Clutch lever assembly	1	
(4)	Left handlebar switch housing screw	2	Tighten the front screw first then the rear one.
(5)	Left handlebar switch housing	1	Align the boss of the housing with the hole in the handlebar.
(6)	Choke cable	1	
(7)	Handlebar weight	1	Align its boss with the inner weight.
(8)	Handle grip	1	Apply Honda Bond A or an equivalent to the inside surface of the grip.
(9)	Choke lever	1	
(10)	Stopper ring	1	
(11)	Handlebar pinch bolt	1	Tighten the pinch bolt while pushing the handlebar forward.
(12)	Left handlebar	1	Align the handlebar boss with the top bridge slot.

Front Wheel Removal/Installation

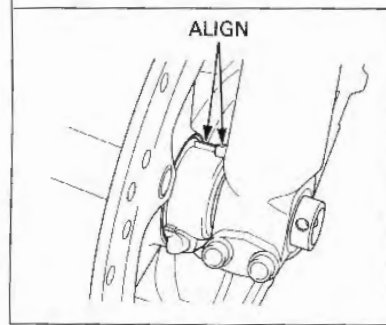
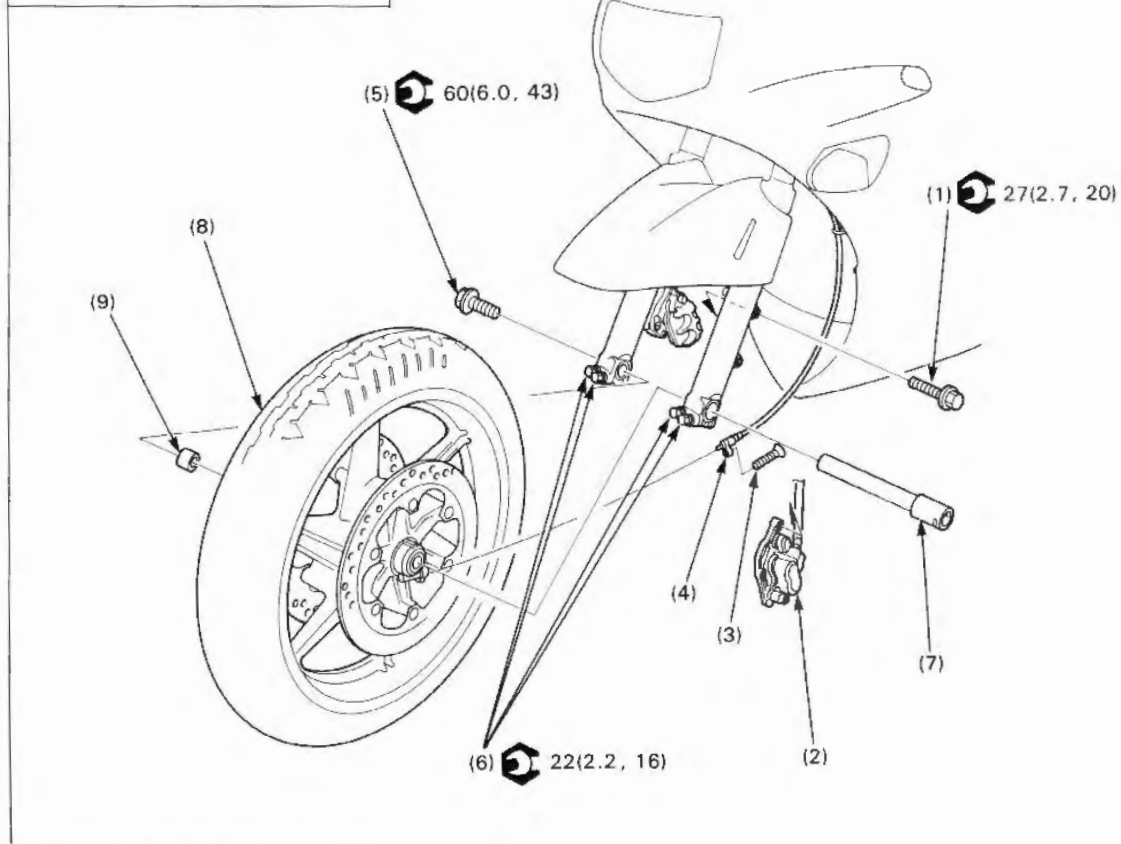
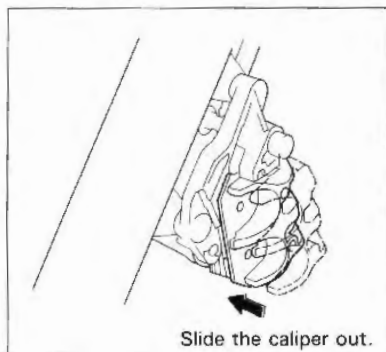

▲ WARNING

- A contaminated brake disc or pad reduces stopping power. Discard contaminated pads and clean a contaminated disc with a high quality brake degreasing agent.

CAUTION

- Do not suspend the brake caliper from the brake hose. Do not twist the brake hose.

NOTE

- Do not apply the brake lever after the front wheel is removed.
- Apply thin coat clean grease to the front axle before installation.
- Check the clearance between the brake disc and caliper bracket on each side after installation. The clearance should be at least 0.7 mm (0.03 in).

Requisite Service

- Raise the front wheel off the ground by suspending the frame with a sling.

Procedure	Q'ty	Remarks
Removal Order		Installation is in the reverse order of removal.
(1) Caliper bracket bolt	2	
(2) Left brake caliper assembly	1	
(3) Speedometer cable screw	1	
(4) Speedometer cable	1	
(5) Front axle bolt	1	
(6) Front axle pinch bolt	4	
(7) Front axle	1	
(8) Front wheel assembly	1	NOTE <ul style="list-style-type: none"> • When installing or removing, slide the right brake caliper out so that the wheel rim clears. • When installing, align the stopper on the speedometer gear box with the tab on the left fork slider.
(9) Right side collar	1	

Front Wheel Disassembly/Assembly

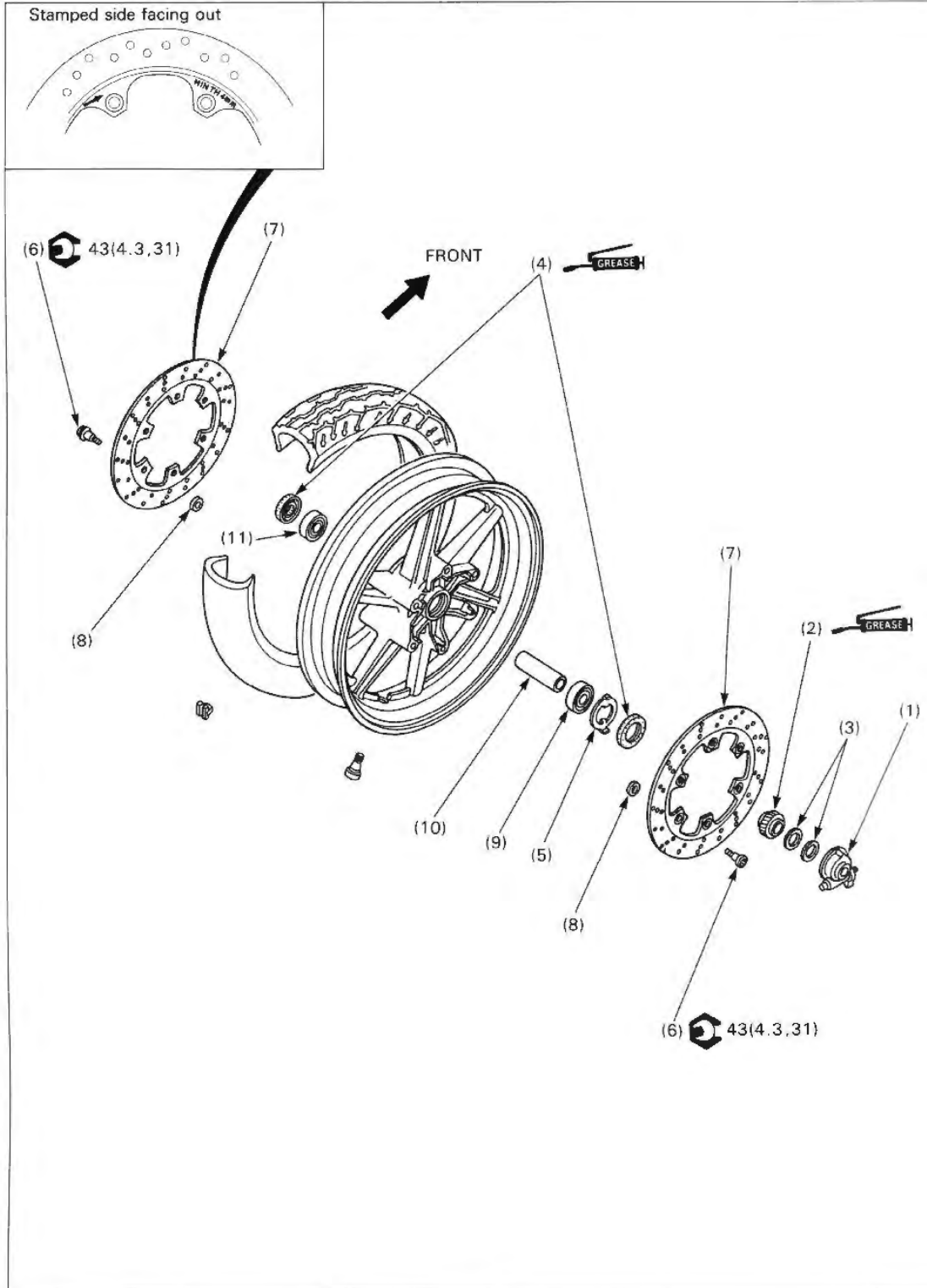

▲ WARNING

- A contaminated brake disc or pad reduces stopping power. Discard contaminated pads and clean a contaminated disc with a high quality brake degreasing agent.

NOTE

- Replace the wheel bearings in pairs.
- Do not add more than 60 grams of balance weights to the wheel balance weight.

Requisite Service

- Front wheel removal/installation (page 12-4)

Procedure	Q'ty	Remarks
Disassembly Order		
(1) Speedometer gear box	1	Assembly is in the reverse order of disassembly. When installing, engage the tabs on the speedometer gear with the tangs of the retainer. NOTE <ul style="list-style-type: none"> • Install each brake disc to its original location. • Install each brake disc with the stamped side facing out and the direction arrow pointing in the direction of rotation.
(2) Speedometer gear	1	
(3) Washer	2	
(4) Dust seal	2	
(5) Speedometer gear retainer	1	
(6) Brake disc bolt	12	
(7) Brake disc	2	
(8) Shim	12	
(9) Left wheel bearing(6004)	1	
(10) Distance collar	1	
(11) Right wheel bearing (6004)	1	

Fork Removal/Installation

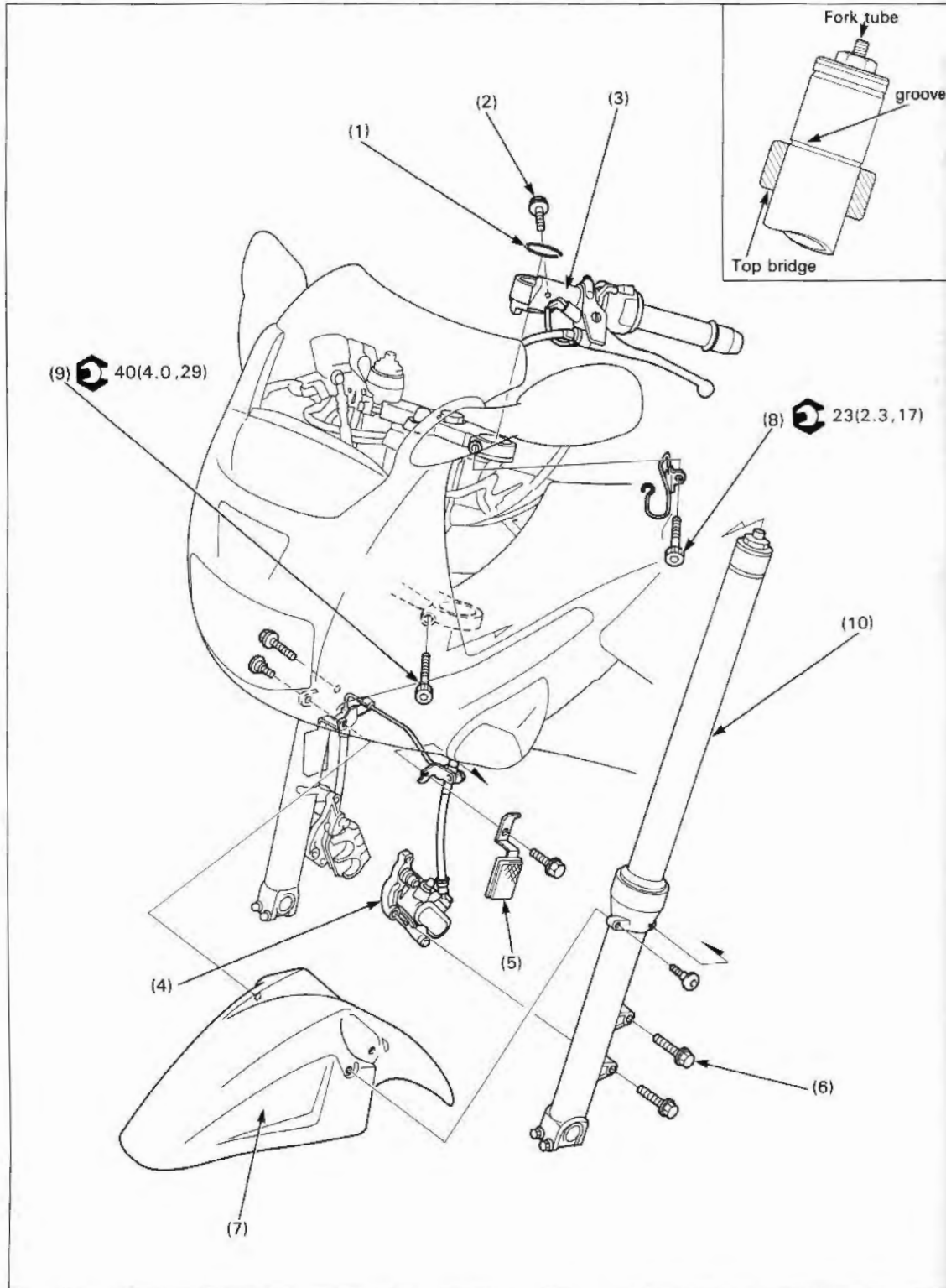

NOTE

- Do not depress the brake lever when the calipers are removed, or it will be difficult to refit the disc between the brake pads.
- If you plan to disassemble the forks legs, loosen the top bridge bolts first then the fork cap bolts but do not remove them at this time.
- Suspend the right and left handlebars properly so that the cables and wires are not bent tightly.

Requisite Service

- Front wheel removal (page 12-4)

Procedure	Q'ty	Remarks
Removal Order		
(1) Stopper ring	2	
(2) Handlebar pinch bolt	2	
(3) Right/Left handlebar assembly	1/1	
(4) Front brake caliper assembly	2	Be careful not to damage the brake pipe.
(5) Socket bolt	2	
(6) Front fender	1	
(7) Top bridge pinch bolt	2	
(8) Bottom bridge pinch bolt	2	Be sure to hold the fork leg while loosening the bolts.
(9) Fork leg assembly	2	
Installation Order		
(9) Fork leg assembly	2	Install the fork leg assembly aligning the groove in the fork tube with the upper surface of the fork top bridge.
(8) Bottom bridge pinch bolt	2	
(7) Top bridge pinch bolt	2	
(6) Front fender	1	
(5) Socket bolt	2	
(4) Front brake caliper assembly	2	
(3) Right/Left handlebar assembly	1/1	Align the handlebar boss with the top bridge slot.
(2) Handlebar pinch bolt	2	Tighten the pinch bolt while pushing the handlebar forward.
(1) Stopper ring	2	

Fork Disassembly ('91-'93)

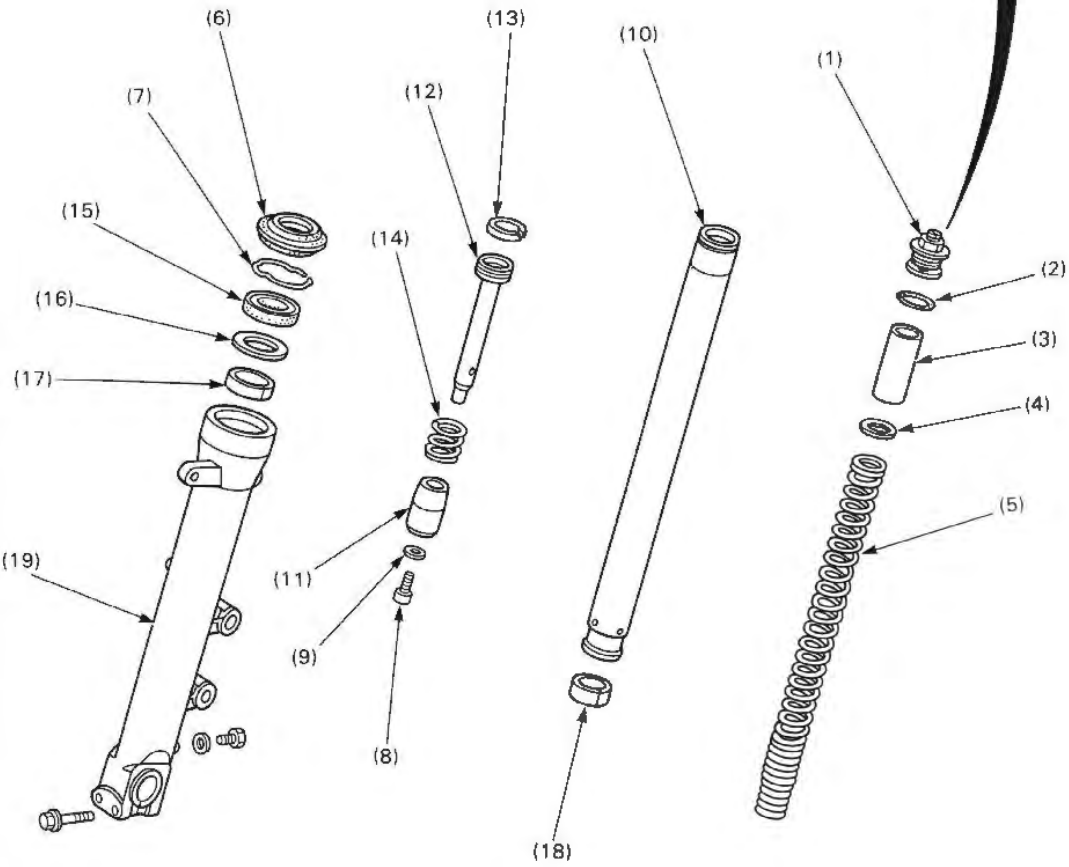

⚠ WARNING

- The fork tube cap is under spring pressure. Use care when removing it and wear eye and face protection.

NOTE

- Temporarily install the fork spring, spring seat, spacer and fork tube cap to loosen the socket bolt.

Requisite Service

- Fork removal/installation (page 12-8)

Procedure	Q'ty	Remarks
(1) Fork cap	1	Before removing the fork cap, turn the preload adjuster counterclockwise fully to lessen spring pressure.
(2) O-ring	1	
(3) Spacer	1	
(4) Spring seat	1	
(5) Fork spring	1	After removing the spring, pour out any remaining fork oil.
(6) Dust seal	1	When removing, be careful not damage the fork tube sliding surface.
(7) Stopper ring	1	
(8) Fork socket bolt	1	
(9) Sealing washer	1	
(10) Fork tube	1	
(11) Oil lock piece	1	
(12) Fork piston	1	
(13) Fork piston ring	1	NOTE • Do not remove the fork piston ring unless it is necessary to replace it.
(14) Rebound spring	1	
(15) Oil seal	1	
(16) Back up ring	1	
(17) Slider bushing	1	
(18) Fork tube bushing	1	NOTE • Do not remove the fork piston ring unless it is necessary to replace it.
(19) Fork slider	1	

Fork Disassembly (After '93)

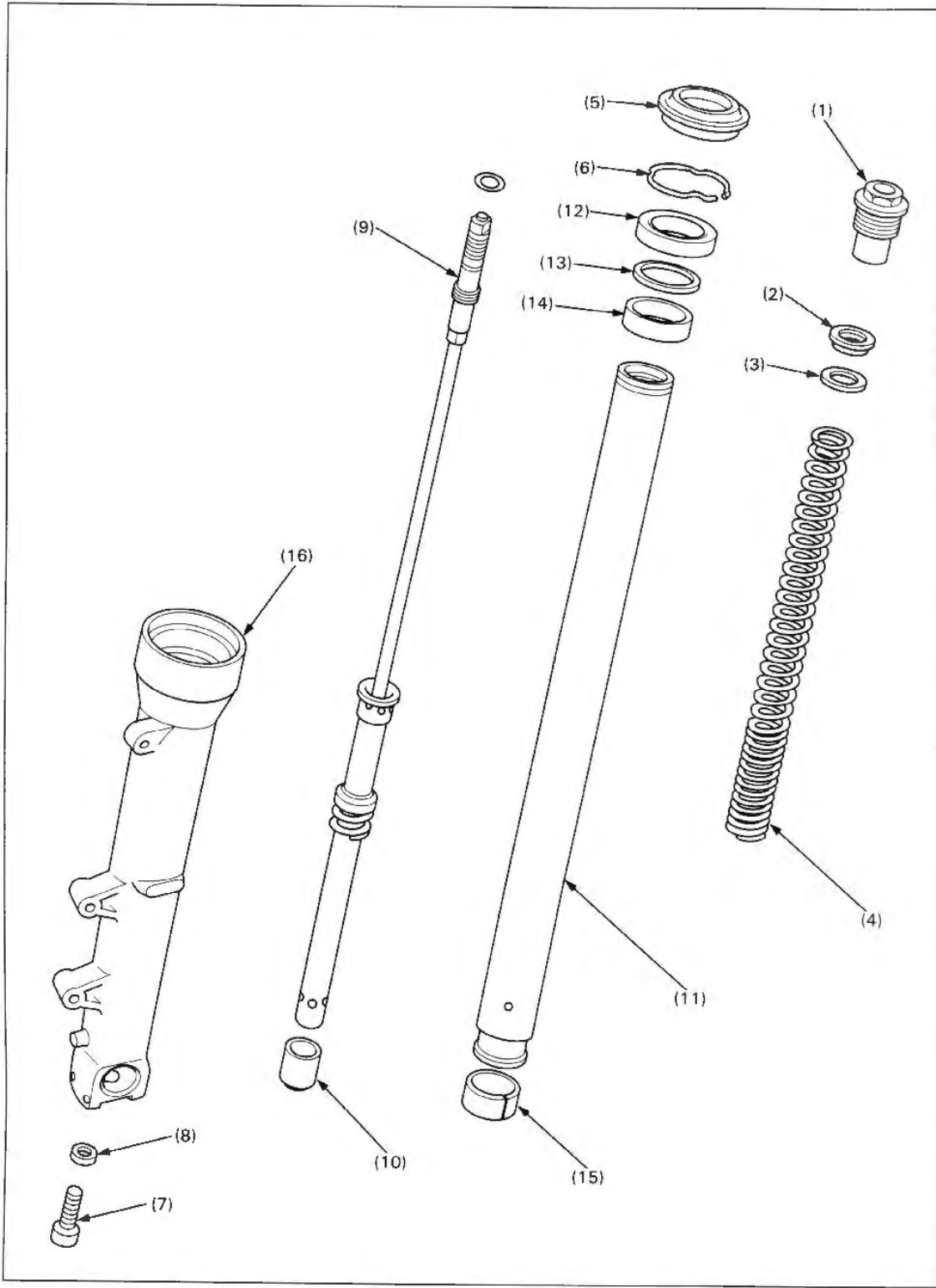

⚠ WARNING

- The fork cap is under spring pressure. Use care when removing it and wear eye and face protection.

NOTE

- Temporarily install the fork spring, spring seat and fork cap to loosen the socket bolt.

Requisite Service

- Fork removal/installation (page 12-8)

Procedure		Q'ty	Remarks	
Disassembly Order				
(1)	Fork cap	1	Before removing the fork cap, turn the preload adjuster counterclockwise fully to loosen spring pressure.	
(2)	Spring seat	1		
(3)	Spring joint plate	1	Pour out the fork fluid after removing the fork spring.	
(4)	Fork spring	1		
(5)	Dust seal	1		
(6)	Stopper ring	1	CAUTION: • Do not scratch the fork tube sliding surface.	
(7)	Fork socket bolt	1	Remove from the fork tube.	
(8)	Sealing washer	1		
(9)	Fork piston	1		
(10)	Oil lock piece	1		
(11)	Fork tube	1		
(12)	Oil seal	1		
(13)	Back-up ring	1		
(14)	Slider bushing	1		
(15)	Fork tube bushing	1		Do not remove it, unless it is necessary to replace it with a new one.
(16)	Fork slider	1		

Fork Assembly ('91-'93)

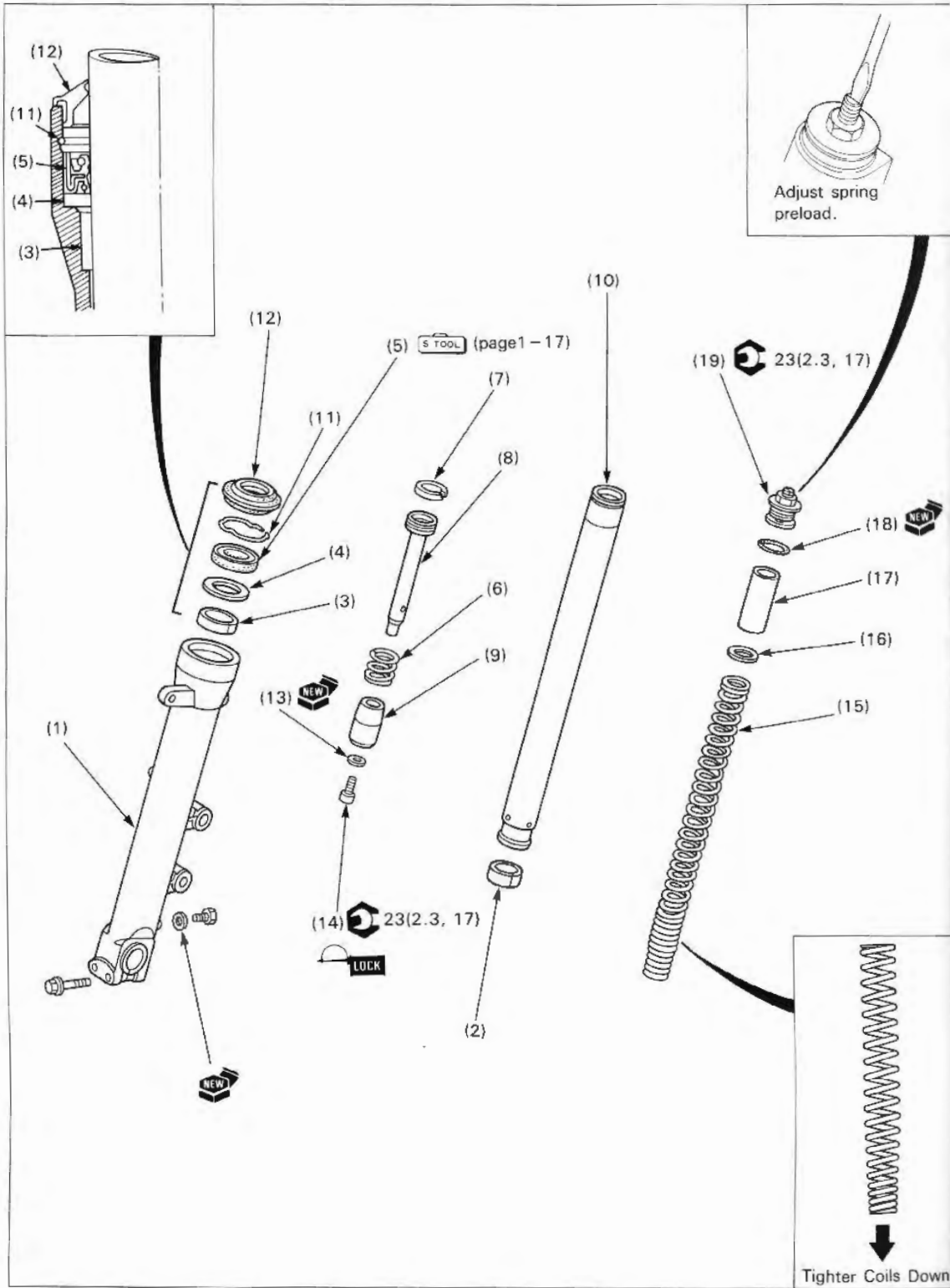

NOTE

- After assembling the fork legs, install each fork leg onto the steering stem first, then torque the fork tube cap and the top bridge pinch bolt.
- Install the back up ring with the chamfered surface side facing down.
- Coat a new oil seal with the recommended fork oil and install with seal mark facing up.

Requisite Service

- Fork installation (page 12-8)

Procedure		Q'ty	Remarks
(1)	Fork slider	1	
(2)	Fork tube bushing	1	Replace with a new one if it was removed from the fork tube.
(3)	Slider bushing	1	
(4)	Back up ring	1	
(5)	Oil seal	1	NOTE <ul style="list-style-type: none"> • Install the oil seal with the marked side facing out. • Wrap the fork tube top end with vinyl tape to prevent the oil seal lip from causing damage.
(6)	Rebound spring	1	
(7)	Fork piston ring	1	
(8)	Fork piston	1	
(9)	Oil lock piece	1	
(10)	Fork tube	1	Drive the oil seal into the fork slider with the Fork Seal Driver (07947-KA50100) and Attachment (07947-KF00100) until the oil seal seats completely.
(11)	Stopper ring	1	When installing, be careful not to damage the fork tube sliding surface.
(12)	Dust seal	1	
(13)	Sealing washer	1	
(14)	Fork socket bolt	1	NOTE <ul style="list-style-type: none"> • After tightening, compress fork tube fully and pour the specified amount of fork fluid (page 1-11) into the fork tube.
(15)	Fork spring	1	NOTE <ul style="list-style-type: none"> • Wipe oil off the spring thoroughly using a clean lint free cloth or high flash point solvent and compressed air and install with the tightly wound coil facing down.
(16)	Spring seat	1	
(17)	Spacer	1	
(18)	O-ring	1	
(19)	Fork tube cap	1	NOTE <ul style="list-style-type: none"> • Before installing, make sure the preload adjuster is turned counterclockwise fully. After installing, adjust fork spring preload.

Fork Assembly (After '93)

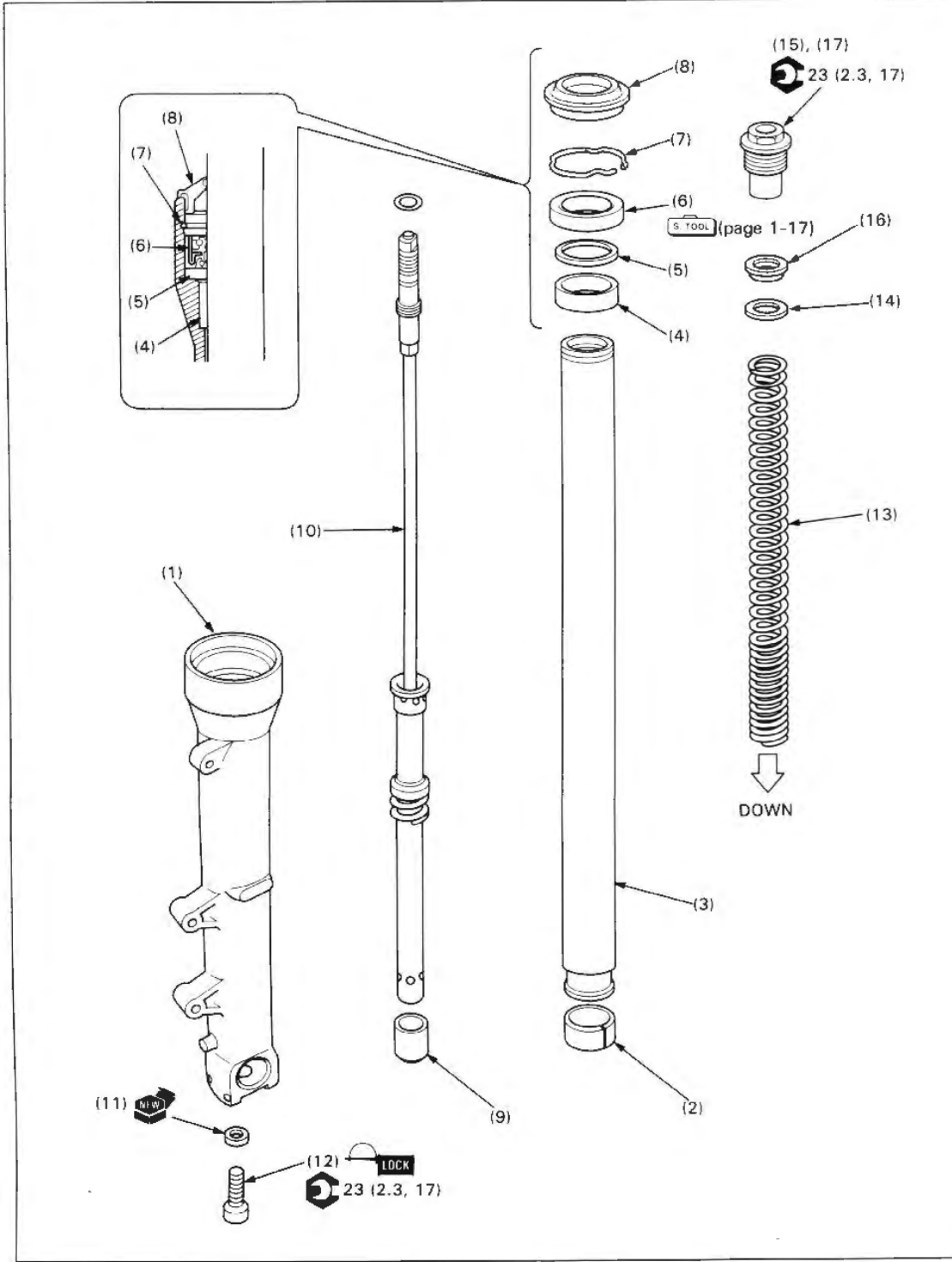

NOTE

- After assembling the fork legs, install them into the steering stem first, then torque the fork cap and the top bridge pinch bolt.
- Install the back up ring with the chambered surface side facing down.
- Coat a new oil seal with the recommended fork oil and install with seal mark facing up.

Requisite Service

- Fork installation (page 12-8)

Procedure		Q'ty	Remarks
	Assembly Order		
(1)	Fork slider	1	
(2)	Fork tube bushing	1	<ul style="list-style-type: none"> • Install them on the fork tube. • Drive the oil seal using special tools. • Use the fork seal driver (07947—KA50100) and attachment (07947—KF00100) for oil seal installation.
(3)	Fork tube	1	
(4)	Slider bushing	1	
(5)	Back-up ring	1	
(6)	Oil seal	1	
(7)	Stopper ring	1	
(8)	Dust seal	1	
(9)	Oil lock piece	1	
(10)	Fork piston	1	
(11)	Sealing washer	1	
(12)	Fork socket bolt	1	
(13)	Fork spring	1	
(14)	Spring joint plate	1	
(15)	Fork cap	1	Install it onto the adjuster.
(16)	Spring seat	1	
(17)	Fork cap	1	<p>CAUTION:</p> <ul style="list-style-type: none"> • Be careful not to cross-thread the fork cap. • Screw in the fork cap but do not tighten yet.

Steering Stem Removal/Installation

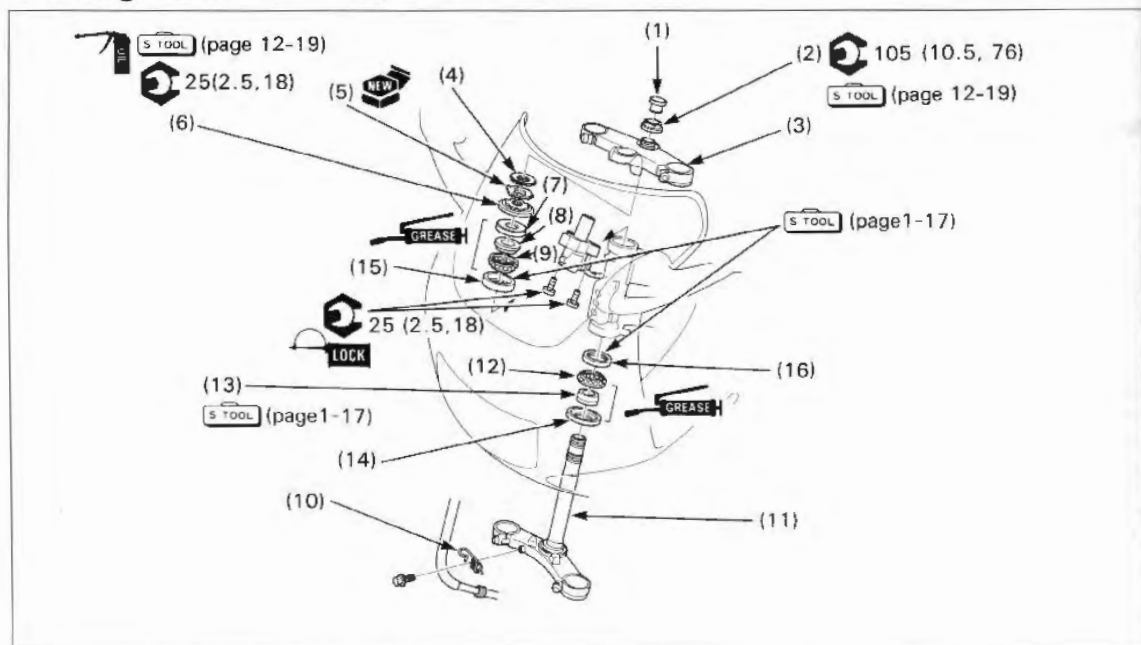

NOTE

- Replace each bearing and bearing race as a set.
- Do not reuse the lock washer.

Requisite Service

- Fork removal/installation (page 12-8)
- Ignition switch removal/installation (page 18-8)

Procedure		Q'ty	Remarks
Removal Order			Installation is in the reverse order of removal.
(1)	Steering stem nut cap	1	
(2)	Steering stem nut	1	
(3)	Fork top bridge	1	
(4)	Lock nut	1	Before removing, bend straight the tabs of the lock washer.
(5)	Lock washer	1	
(6)	Steering adjustment nut	1	Refer to page 12-19 for installation. Hold the steering stem while removing the adjustment nut.
(7)	Dust seal	1	
(8)	Upper inner race	1	
(9)	Ball bearing	1	
(10)	Brake hose clamp	1	
(11)	Steering stem	1	
(12)	Ball bearing	1	
(13)	Lower inner race	1	
(14)	Dust seal	1	
(15)	Upper outer race	1	
(16)	Lower outer race	1	

Bearing Adjustment Nut Removal/Installation

Bend the tabs of the lock washer straight and then remove the lock nut and lock washer.

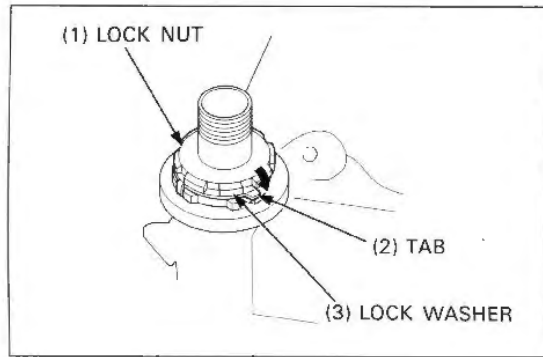

Remove the steering adjustment nut.

STOOL

Steering stem socket
Extension bar

07916-3710100
07716-0020500 or
equivalent commercially
available in U.S.A.

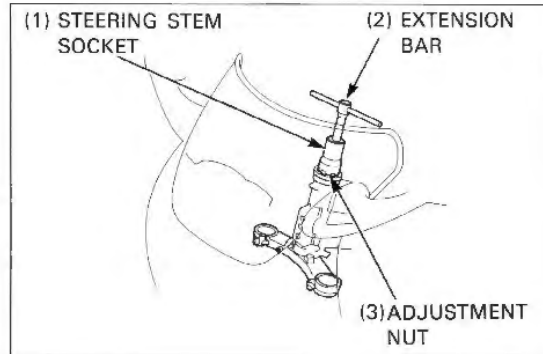

Apply clean engine oil to the steering adjustment nut threads and tighten the adjustment nut to the specified torque.

STOOL

Steering stem socket
Extension bar

07916-3710100
07716-0020500 or
equivalent commercially
available in U.S.A.

Torque: 25 N · m (2.5kg-m, 18 ft-lb)

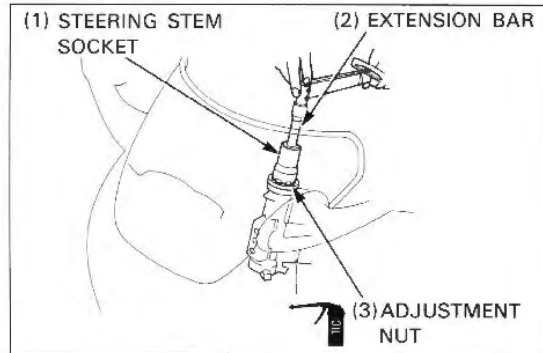

Turn the steering stem lock to lock at least five times, then retighten the steering adjustment nut to the specified torque.

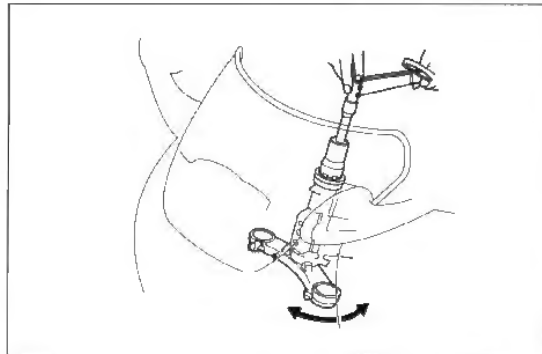

Front Wheel/Suspension/Steering

Bend the opposite tabs of a new lock washer down and then install it onto the steering adjustment nut while aligning the tabs with the grooves in the adjustment nut.

Finger tighten the lock nut.

Hold the adjustment nut and further tighten the lock nut within 1/4 turn (90°) enough to align its grooves with the lock washer tabs.

Bend the lock washer tabs up into the lock nut grooves.

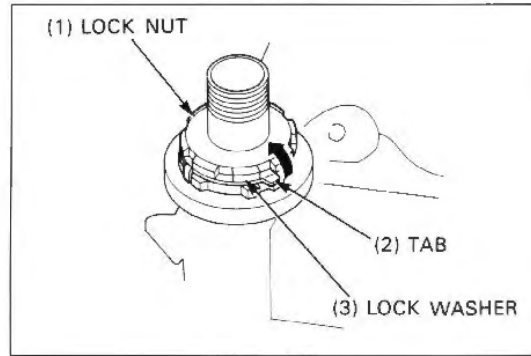

13. Rear Wheel/Suspension

Service Information	13-1	Shock Absorber Disassembly/Assembly ('91-'93)	13-6
Troubleshooting	13-1	Suspension Linkage Removal/Installation	13-8
Rear Wheel Removal/Installation	13-2	Suspension Linkage Disassembly/Assembly	13-9
Rear Wheel Disassembly/Assembly	13-3	Swingarm Removal/Installation	13-12
Shock Absorber Removal/Installation ('91-'93)	13-4	Swingarm Disassembly/Assembly	13-14
Shock Absorber Removal/Installation (After '93)	13-5		

Service Information

- Refer to the section 14 for brake system information.
- Tubeless tire removal, repair and remounting procedures are covered in the section 16 of the Common Service Manual.

Troubleshooting

Rear Wheel Wobbling

- Bent rim
- Worn rear wheel bearings
- Faulty tire
- Unbalanced tire and wheel
- Low tire pressure
- Faulty swingarm pivot bearing(s)

Wheel Turns Hard

- Faulty wheel bearing(s)
- Brake drag (Section 14)
- Bent rear axle

Soft Suspension

- Weak shock absorber spring
- Incorrect suspension adjustment
- Oil leakage from damper unit
- Low tire pressure

Hard Suspension

- Damaged shock absorber mount bushing
- Damaged shock absorber lower joint bearing
- Incorrect suspension adjustment
- Bent damper rod
- Damaged swingarm pivot bearing
- High tire pressure

Suspension Noise

- Shock absorber binding
- Loose fasteners

Rear Wheel Removal/Installation

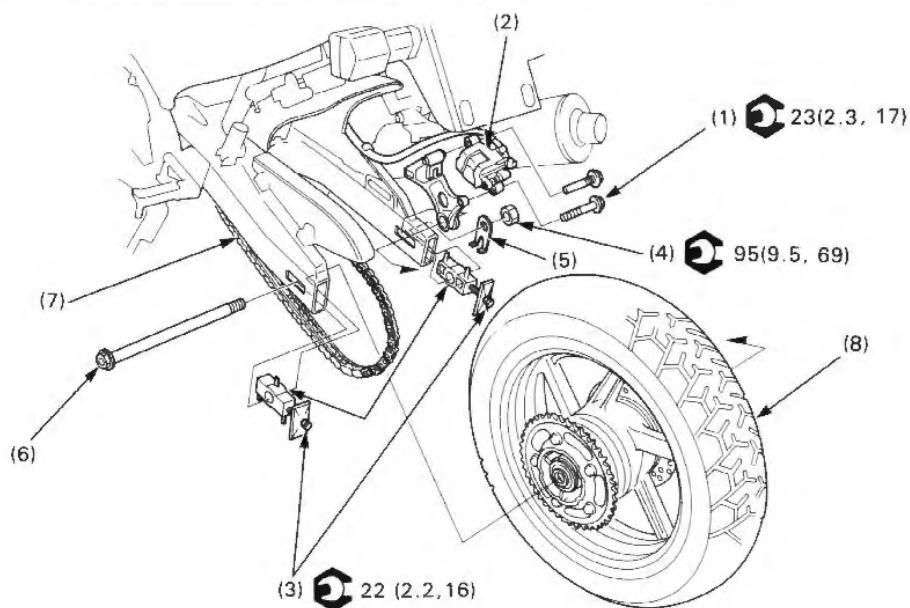

WARNING

- A contaminated brake disc or pad reduces stopping power. Discard contaminated pads and clean a contaminated disc with a high quality brake degreasing agent.

CAUTION

- Do not suspend the brake caliper from the brake hose. Do not twist the brake hose.

NOTE

- Put the motorcycle on its center stand.
- Do not depress the brake pedal when the caliper is removed, or it will be difficult to refit the disc between the brake pads.
- Adjust the drive chain slack after installing the wheel.

Procedure	Q'ty	Remarks
Removal Order		Installation is in the reverse order of removal.
(1) Rear caliper bracket bolt	1	
(2) Rear brake caliper assembly	1	Release the brake hose from the clamp on the rear fender B and pivot the brake caliper upward.
(3) Lock nut/Drive chain adjusting nut	2/2	Loosen them all the way and push the wheel forward all the way.
(4) Rear axle nut	1	
(5) Washer	1	
(6) Rear axle shaft	1	
(7) Drive chain	1	
(8) Rear wheel assembly	1	
(9) Drive chain adjuster	1	Install the drive chain adjusters with the graduated side facing out.

Rear Wheel Disassembly/Assembly

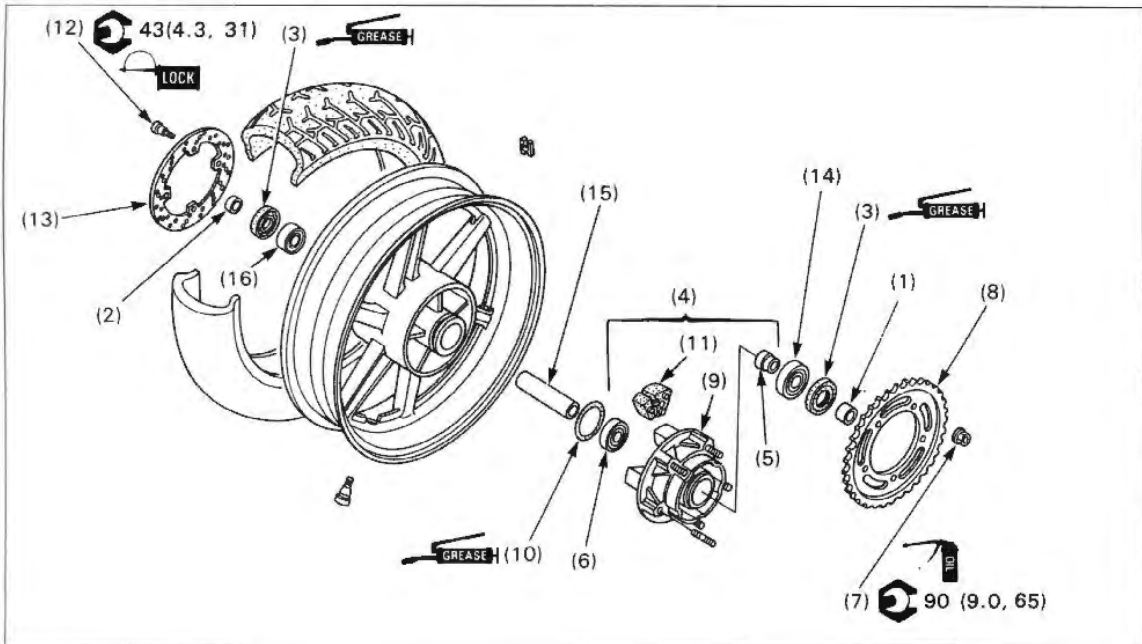

WARNING

- A contaminated brake disc or pad reduces stopping power. Discard contaminated pads and clean a contaminated disc with a high quality brake degreasing agent.

NOTE

- Replace the wheel bearings in pairs.
- Do not add more than 60 grams of balance weights to the wheel.

Requisite Service

- Rear wheel removal/installation (page 13-2)

Procedure	Q'ty	Remarks
Disassembly Order		Assembly is in the reverse order of disassembly.
(1) Left side collar	1	
(2) Right side collar	1	
(3) Dust seal	2	
(4) Driven flange assembly	1	
(5) -Driven flange collar	1	
(6) -Driven flange bearing (62/22)	1	
(7) -Driven sprocket nut	4	
(8) -Driven sprocket	1	Install the driven sprocket with the stamped side facing out.
(9) -Driven flange	1	
(10) O-ring	1	
(11) Rear wheel damper	5	
(12) Brake disc bolt	4	
(13) Brake disc	1	Install the brake disc with the stamped side facing out.
(14) Left wheel bearing (6204UU)	1	
(15) Distance collar	1	
(16) Right wheel bearing (6204UU)	1	

Shock Absorber Removal/Installation ('91-'93)

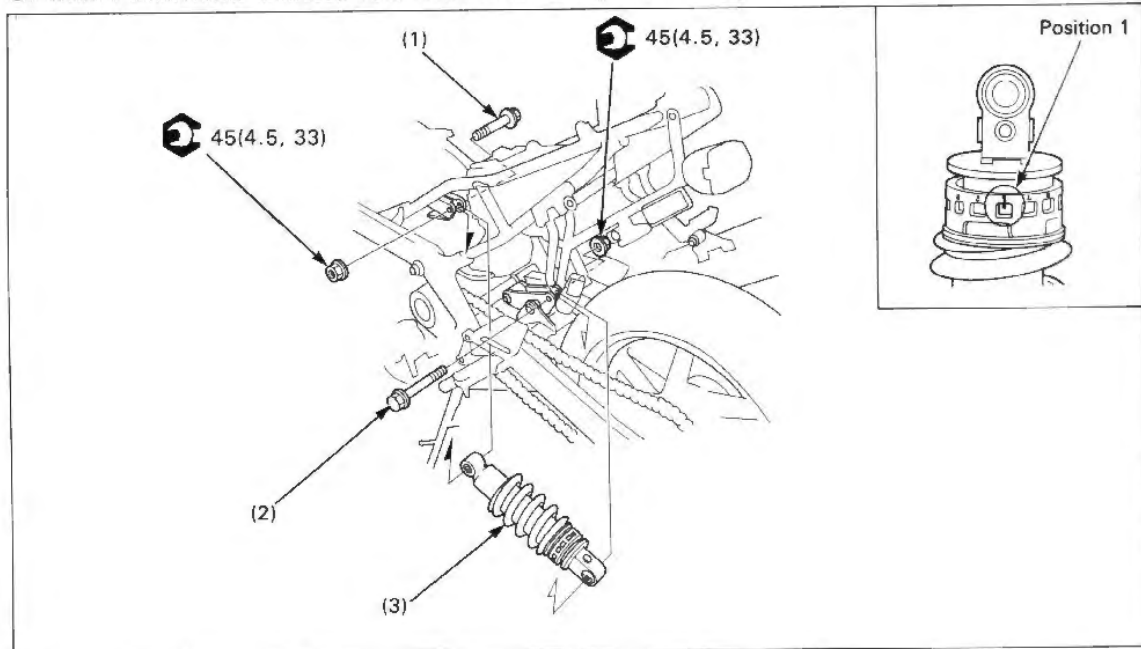

NOTE

- Support the motorcycle securely in an upright position.
- If you plan to disassemble the shock absorber, adjust it to position 1 (for lightest loads) before removing it from the frame.

Requisite Service

- Side cover removal/installation (page 2-2)
- Rear fender B removal/installation (page 2-7)

Procedure	Q'ty	Remarks
Removal Order		Installation is in the reverse order of removal.
(1) Shock absorber mounting bolt (upper)	1	Install the bolt from the right side.
(2) Shock absorber mounting bolt (lower)	1	Install the bolt from the left side.
(3) Shock absorber assembly	1	Install the shock absorber assembly with the rebound damping adjuster facing the right side.

Shock Absorber Removal/Installation (After '93)

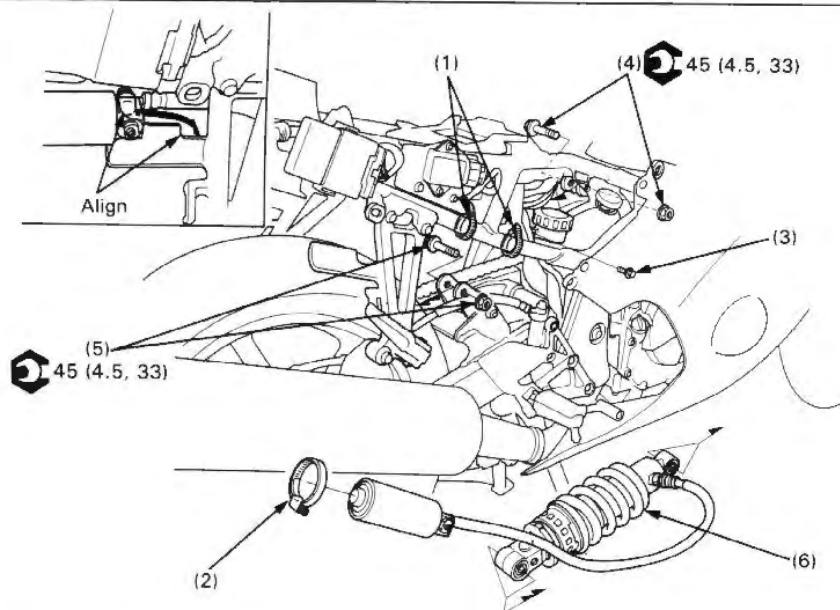

▲ WARNING

- The shock absorber contains nitrogen under high pressure. Do not allow fire or heat near the shock absorber.
- Before disposal of shock absorber, release the nitrogen.
(Step : section 19 of the Common Service Manual ; Drilling point : page 1-11)

NOTE

- Put the motorcycle on its centerstand.

Requisite Service

- Side cover removal/installation (page 2-2)
- Rear fender B removal/installation (page 2-7)

Procedure	Q'ty	Remarks
Removal Order		Installation is in the reverse order of removal.
(1) Reservoir hose band	2	
(2) Reservoir holder	1	
(3) Rear brake master cylinder reservoir mount bolt	1	
(4) Shock absorber mounting bolt/nut (upper)	1/1	Install the bolt from the left side.
(5) Shock absorber mounting bolt/nut (lower)	1/1	Install the bolt from the left side.
(6) Shock absorber assembly	1	<ul style="list-style-type: none"> • Install the shock absorber assembly with the rebound damping adjuster facing the right side. • At installation, align the reservoir hose end with the cut off of the frame.

Shock Absorber Disassembly/Assembly ('91-'93)

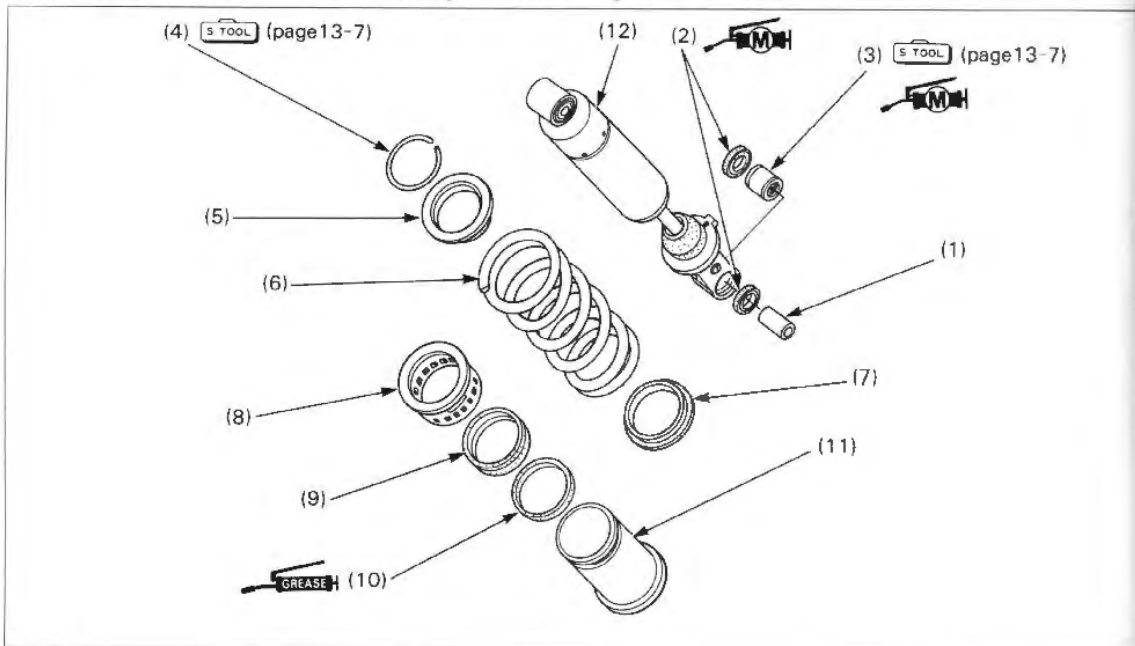
**WARNING**

- The shock absorber contains nitrogen under high pressure. Do not allow fire or heat near the shock absorber.
- Before disposal of shock absorber, release the nitrogen.

(Step : section 19 of the Common Service Manual ; Drilling point : page 1-11)

Requisite Service

- Shock absorber removal/installation (page 13-4)

Procedure	Q'ty	Remarks
Disassembly Order		Assembly is in the reverse order of disassembly.
(1) Lower mount collar	1	
(2) Dust seal	1	
(3) Needle bearing	1	Refer to page 13-7 for replacement.
(4) Stopper ring	1	Refer to page 13-7 for removal and installation.
(5) Upper spring seat	1	
(6) Spring	1	
(7) Lower spring seat	1	
(8) Spring pre-load adjuster	1	
(9) Dust seal	1	
(10) Inner spring seat	1	
(11) Spring guide	1	Install the spring guide aligning the cutout in the guide with the tab on the spring guide stopper.
(12) Damper unit assembly	1	

Stopper Ring Removal/Installation

Remove the stopper ring by compressing the shock absorber with a hydraulic press.

S TOOL

Oil seal driver attachment 07965-KE80200 or
07964-3710000

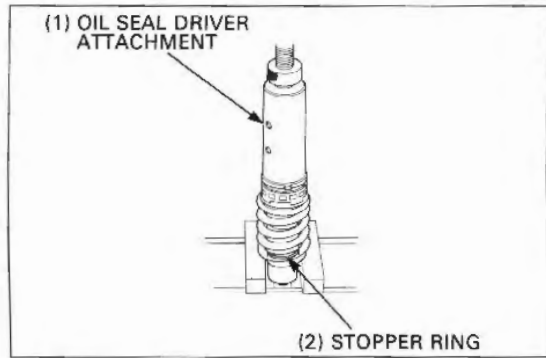

Compress the shock absorber until the groove in the damper unit comes out enough to install the stopper ring.

CAUTION

- Do not compress the spring more than necessary to install the stopper ring or the spring will fatigue.

Install the stopper ring in the groove in the damper unit securely.

NOTE

- Before releasing the hydraulic press, make sure that the lower joint aligns between the tabs on the spring guide stopper.

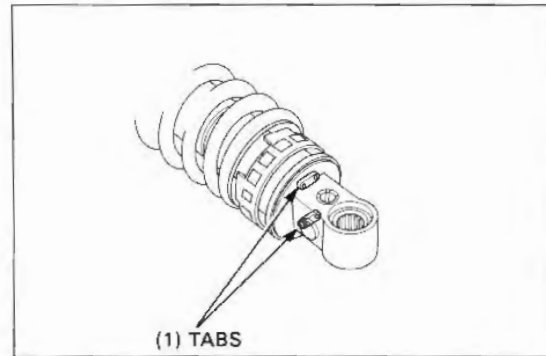

Lower Joint Needle Bearing Replacement

Remove the dust seals from the lower joint.
Hold the lower joint with the suitable tool.
Press the needle bearing out of the lower joint.

S TOOL

Pin driver 07GMD-KT80100 or
Driver 07749-0010000
Pilot, 22 mm 07746-0041000

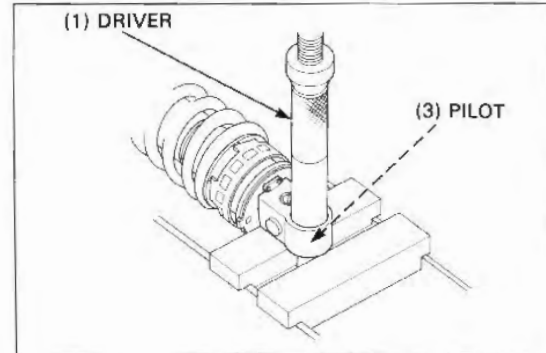

Pack a new needle bearing with molybdenum disulfide grease.

Press the bearing into the lower joint until the bearing surface is flush with the joint surface as shown.

S TOOL

Driver 07749-0010000
Attachment, 24×26 mm 07746-0010700
Pilot, 17 mm 07746-0040400

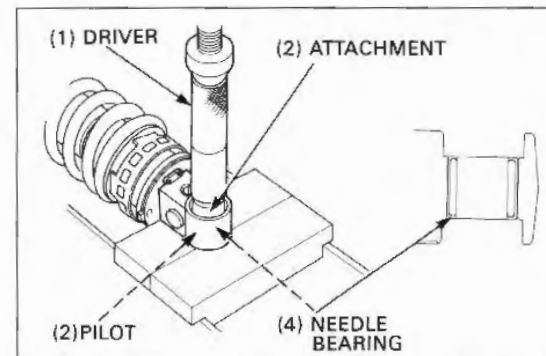

Suspension Linkage Removal/Installation

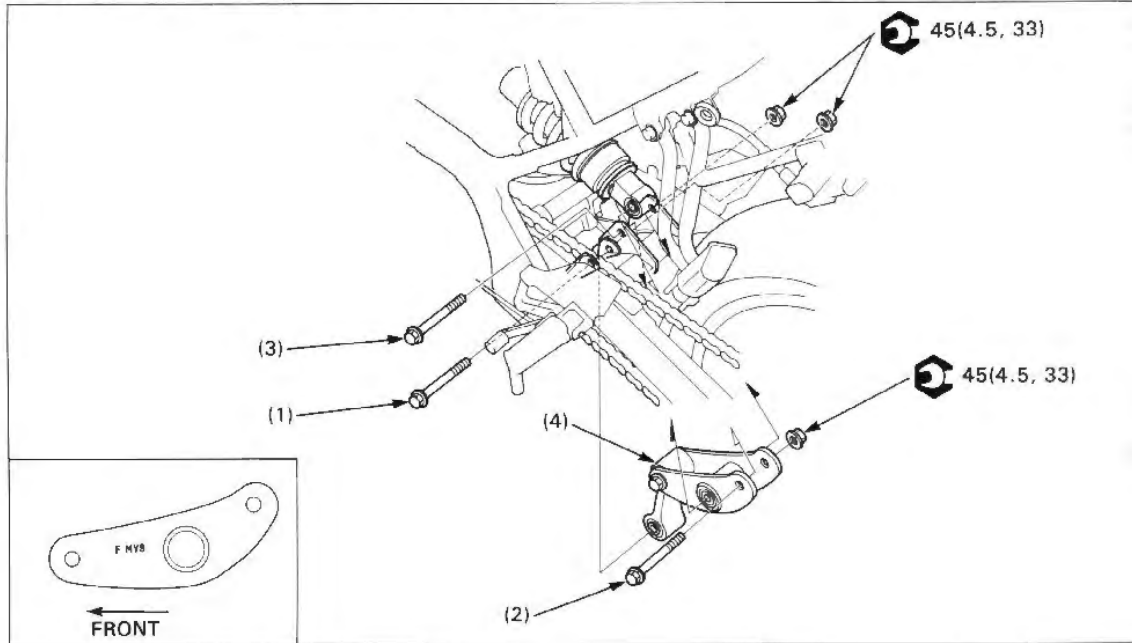

NOTE

- Support the motorcycle securely in an upright position.

Requisite Service

- Rear fender B removal/installation (page 2-7)

Procedure	Q'ty	Remarks
Removal Order		Installation is in the reverse order of removal.
(1) Shock link bolt (shock arm side)	1	
(2) Shock absorber mounting bolt (lower)	1	
(3) Shock link bolt (frame side)	1	
(4) Shock link/Shock arm	1	Install the shock link and shock arm with the mark "←FMV 9" facing the left side.

Suspension Linkage Disassembly/Assembly

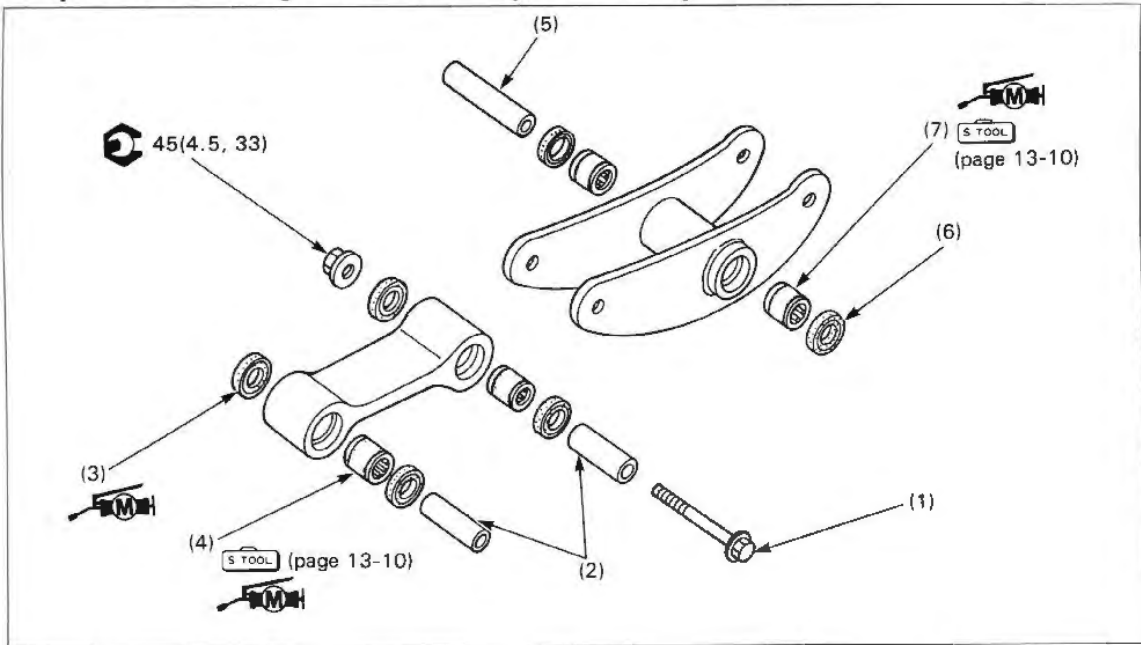

NOTE

- Assemble the shock link and shock arm with the arrow mark "←FMV9" pointing forward.

Requisite Service

- Shock linkage removal/installation (page 13-8)

Procedure	Q'ty	Remarks
Removal Order		Installation is in the reverse order of removal.
(1) Shock arm bolt	1	
(2) Shock link pivot collar	2	
(3) Dust seal	4	
(4) Shock link pivot needle bearing	2	Refer to page 13-10 for replacement.
(5) Shock arm pivot collar	1	
(6) Dust seal	2	
(7) Shock arm pivot needle bearing	1	Refer to page 13-10 for replacement.

Suspension Linkage Pivot Needle Bearing Replacement

Shock Arm

Press the needle bearing out of the shock arm.

S TOOL

Pin driver 07GMD-KT80100 or
 Driver 07949-3710001
 Pilot, 22mm 07746-0041000

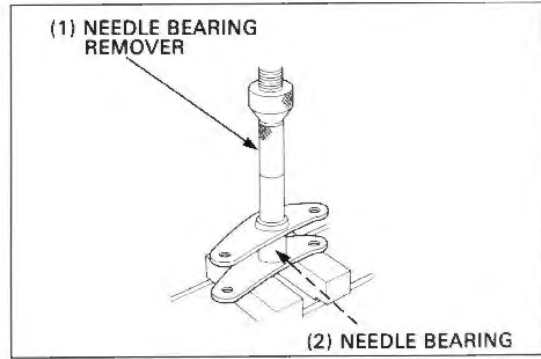

Press a new needle bearing into the shock arm so that the needle bearing outer surface is 6.5 mm (0.26 in) lower from the outer edge of the shock arm pivot bearing cavity.

S TOOL

Driver 07749-0010000
 Attachment, 24×26 mm 07746-0010700
 Pilot, 17 mm 07746-0040400

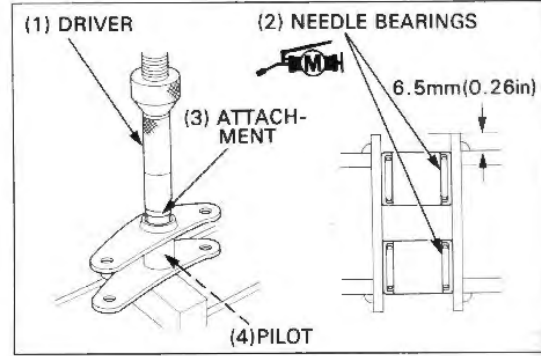

NOTE

- Press the needle bearing in with the stamped side facing out.

Shock Link

Press the needle bearing out of the shock link.

S TOOL

Pin driver 07GMD-KT80100 or
 Driver 07949-3710001
 Pilot, 22 mm 07746-0041000

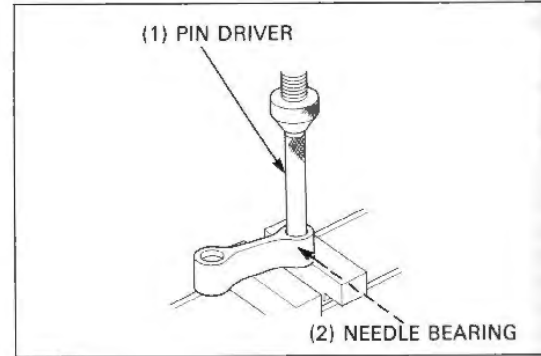

Press a new needle bearing into the shock link so that the needle bearing outer surface is 5.7 mm (0.22 in) lower from the outer edge of the shock link pivot bearing cavity.

S TOOL

Driver 07749-0010000
 Attachment, 24×26 mm 07746-0010700
 Pilot, 17 mm 07746-0040400

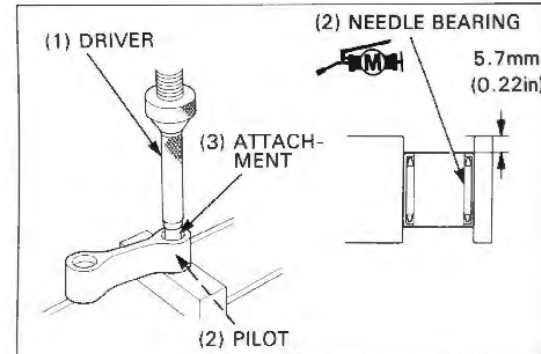

NOTE

- Press the needle bearing in with the stamped side facing out.

MEMO

Swingarm Removal/Installation

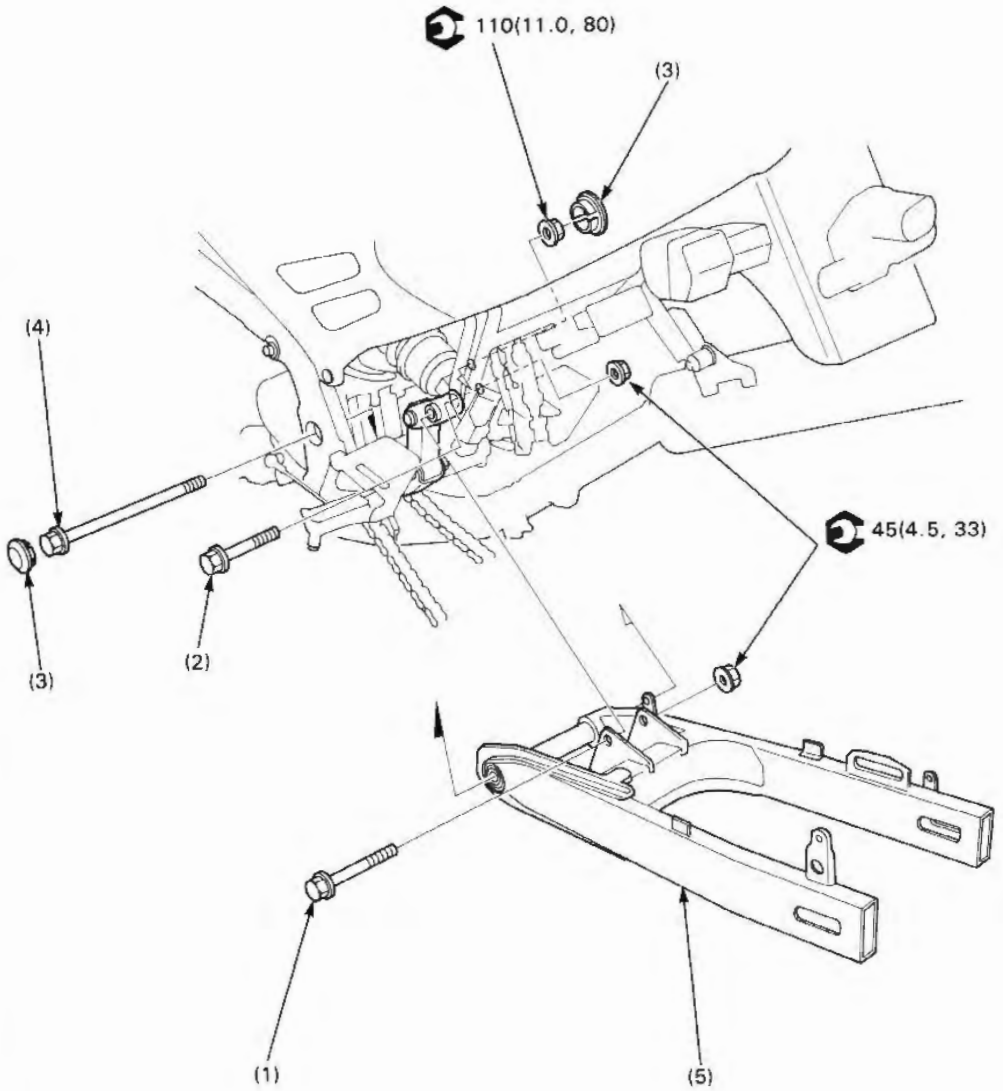

CAUTION

- Do not suspend the brake caliper from the brake hose. Do not twist the brake hose.

NOTE

- Support the motorcycle securely in an upright position.
- Do not depress the brake pedal when the caliper is removed, or it will be difficult to refit the disc between the brake hose.

Requisite Service

- Rear wheel removal/installation (page 13-2)
- Rear fender B removal/installation (page 2-7)

Procedure		Q'ty	Remarks
Removal Order			
(1)	Shock arm bolt	1	
(2)	Shock absorber mounting bolt (lower)	1	
(3)	Swingarm pivot cap	2	
(4)	Swingarm pivot bolt	1	
(5)	Swingarm assembly	1	
Installation Order			
(5)	Swingarm assembly	1	Before installing, pass the drive chain over the swingarm.
(4)	Swingarm pivot bolt	1	
(3)	Swingarm pivot cap	2	
(2)	Shock absorber mounting bolt (lower)	1	
(1)	Shock arm bolt	1	

Swingarm Disassembly/Assembly

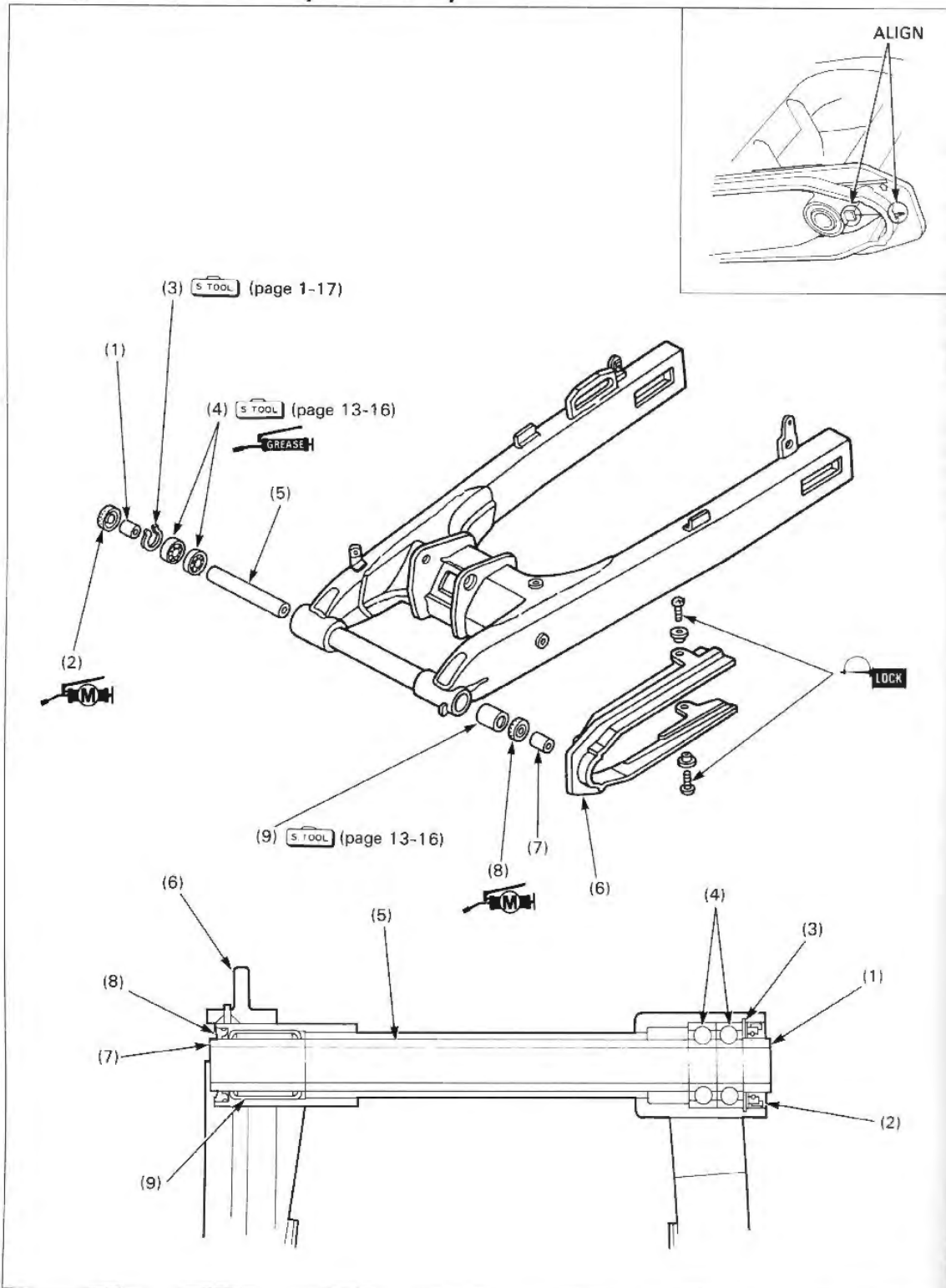

Requisite Service

- Swingarm removal/installation (page 13-12)

Procedure	Q'ty	Remarks
Disassembly Order (1) Right pivot collar (2) Dust seal(22×35×7) (3) Snap ring (4) Right pivot bearing(6202) (5) Distance collar (6) Drive chain slider (7) Left pivot collar (8) Dust seal(22×31×5) (9) Left pivot bearing	1 1 1 2 1 1 1 1 1	Refer to page 13-16 for removal. Refer to page 13-16 for removal.
Assembly Order (9) Left pivot bearing (8) Dust seal(22×31×5) (7) Left pivot collar (6) Drive chain slider (5) Distance collar (4) Right pivot bearing(6202) (3) Snap ring (2) Dust seal(22×35×7) (1) Right pivot collar	1 1 1 1 1 2 1 1 1	Refer to page 13-16 for installation. Align the slot in the chain slider with the tab on the swingarm. Refer to page 13-16 for installation. Install the snap ring with the chamfered side facing in.

Swingarm Pivot Bearing Replacement

Remove the snap ring.

Remove the right pivot bearings (radial ball bearings) from the swingarm.

S TOOL

Bearing remover set	07936-KC10000
-Bearing remover head, 15mm	07936-KC10200
-Remover handle	07936-KC10100
-Remover sliding weight	07741-0010201
or	
Bearing remover, 15mm	07936-KC10500
Remover weight	07936-3710200

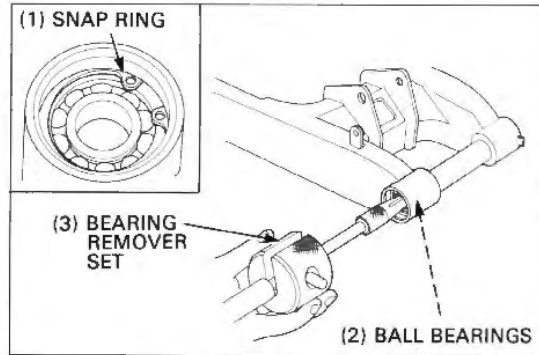

Press new radial ball bearings into the right swingarm pivot one at a time.

S TOOL

Driver	07749-0010000
Attachment, 32×35 mm	07746-0010100
Pilot, 15 mm	07746-0040300

NOTE

- Install the bearing with the stamped side facing out.

Install the snap ring with the chamfered side facing in.

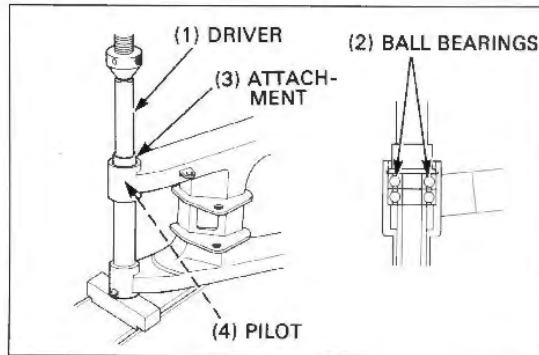

Press the needle bearing out of the left swingarm pivot.

S TOOL

Needle bearing remover	07GMD-KT70200
Driver shaft	07949-MJ00100
or	
Bushing remover	M967X-038-XXXXX
Driver	07949-3710001

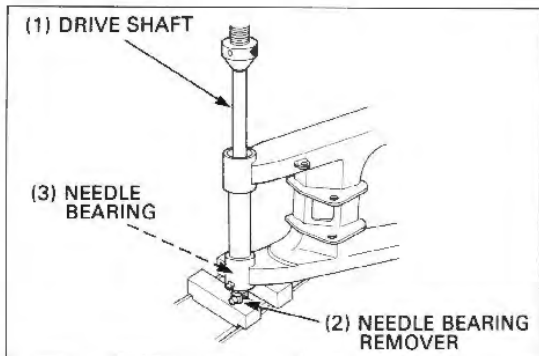

Press a new needle bearing with the stamped side facing out.

S TOOL

Driver	07749-0010000
Attachment, 28×30 mm	07946-1870100
Pilot, 22 mm	07746-0041000

NOTE

- The bearing surface should be flush with the pivot inside surface as shown.

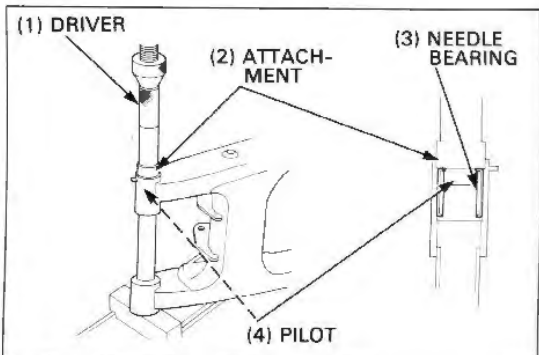

14. Brake System

Service Information	14-1	Front Brake Caliper Disassembly/Assembly	14-6
Troubleshooting	14-1	Rear Master Cylinder Removal/Installation	14-8
Rear Brake Pad Replacement	14-2	Rear Master Cylinder Disassembly/Assembly	14-10
Front Master Cylinder Removal/Installation	14-3	Rear Brake Caliper Removal/Installation	14-11
Front Master Cylinder Disassembly/Assembly	14-4	Rear Brake Caliper Disassembly/Assembly	14-12
Front Brake Caliper Removal/Installation	14-5		

Service Information

▲ WARNING

- A contaminated brake disc or pad reduces stopping ability.
- Mixing incompatible brake fluids will impair braking efficiency.
- Foreign materials can clog the system, causing a reduction or complete loss of braking ability.
- Always reinstall the brake pads in their original positions to prevent loss of braking efficiency.

Troubleshooting

Brake Lever Soft Or Spongy

- Air bubbles in the hydraulic system
- Leaking hydraulic system
- Contaminated brake pad/disc
- Worn caliper piston seal
- Worn master cylinder piston seal
- Worn brake pad/disc
- Contaminated caliper
- Caliper not sliding properly
- Low fluid level
- Clogged fluid passage
- Warped/deformed brake disc
- Sticking/worn caliper piston
- Sticking/worn master cylinder piston
- Contaminated master cylinder
- Bent brake lever

Brake Lever Hard

- Clogged/restricted brake system
- Sticking/worn caliper piston
- Caliper not sliding properly
- Clogged/restricted fluid passage
- Worn caliper piston seal
- Sticking/worn master cylinder piston
- Bent brake lever

Brake Grab or Pull To One Side

- Disc or wheel misaligned
- Contaminated brake pad/disc
- Clogged/restricted brake hose/joint(s)
- Warped/deformed brake disc
- Caliper not sliding properly

Brake Drag

- Contaminated brake pad/disc
- Disc or wheel misaligned
- Worn brake pad/disc
- Warped/deformed brake disc
- Caliper not sliding properly

Rear Brake Pad Replacement

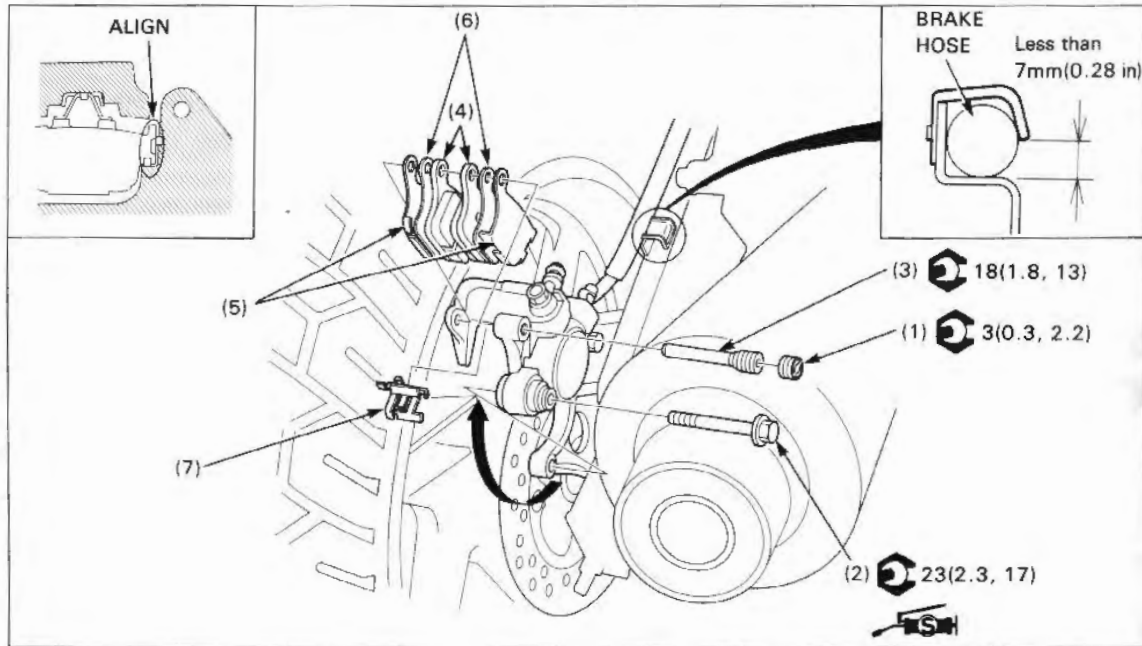

▲ WARNING

- Do not get grease on the brake disc or stopping power will be reduced.
- Discard contaminated pads and clean a contaminated disc with a high quality brake degreasing agent.
- Check the brake system by applying the brake after pad replacement.

NOTE

- Operate the brake pedal to seat the caliper piston against the pads after pad replacement.
- The brake pad replacement can be serviced without disconnecting the hydraulic system.
- Always replace the brake pads in pairs to assure even disc pressure.

Procedure	Q'ty	Remarks
Removal Order		Installation is in the reverse order of removal.
(1) Pad pin plug	1	After removing the pad pin plug, loosen the pad pin.
(2) Rear caliper bracket bolt	1	<ul style="list-style-type: none"> • After removing the bolt, release the brake hose from the clamp on the rear fender B and pivot the rear brake caliper assembly upward. • Clamp the brake hose so that the clamp opening is less than 7mm (0.28 in).
(3) Pad pin	1	
(4) Brake pad	2	Position the pad onto the pad retainer in the caliper as shown.
(5) Brake pad shim	2	
(6) Brake pad insulator	2	
(7) Brake pad spring	1	

Front Master Cylinder Removal/Installation

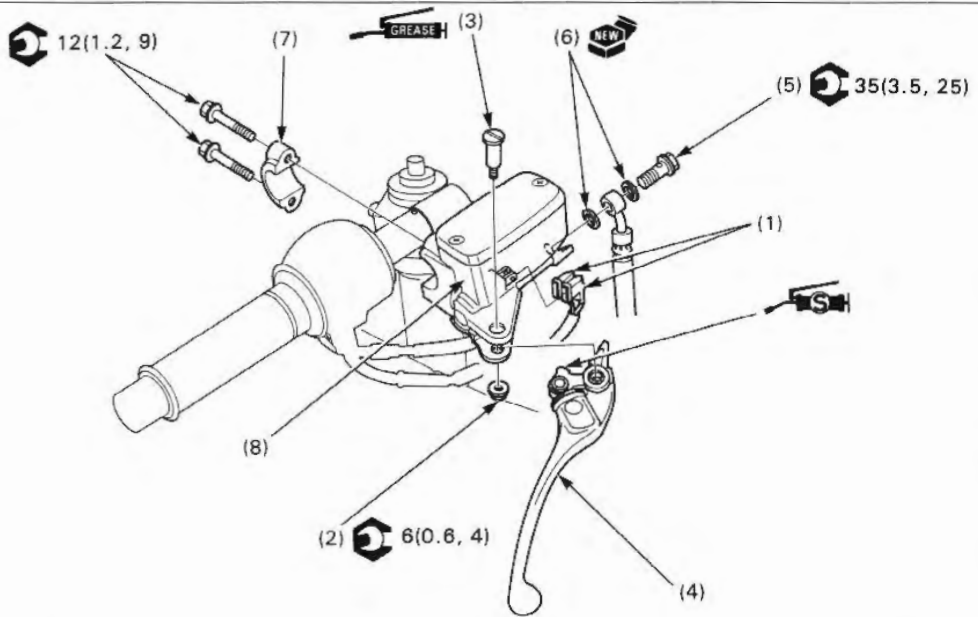

▲ WARNING

- Check the brake system by applying the brake after air bleeding.

CAUTION

- Avoid spilling fluid on painted, plastic, or rubber parts. Place a rag over these parts whenever the system is serviced.
- When removing the brake hose bolt, cover the end of the brake hose to prevent contamination.
- Do not allow foreign material to enter the system.

NOTE

- Use only DOT 4 brake fluid from a sealed container.
- If you plan to disassemble the master cylinder, remove the brake lever.

Procedure	Q'ty	Remarks
Removal Order		Installation is in the reverse order of removal.
(1) Brakelight switch connector	2	
(2) Brake lever pivot nut	1	
(3) Brake lever pivot bolt	1	
(4) Brake lever	1	
(5) Brake hose bolt	1	
(6) Sealing washer	2	
(7) Brake master cylinder holder	1	Align the holder mating surface with the punch mark on the handlebar and face the holder with the "UP" mark facing up.
(8) Front master cylinder assembly	1	

Front Master Cylinder Disassembly/Assembly

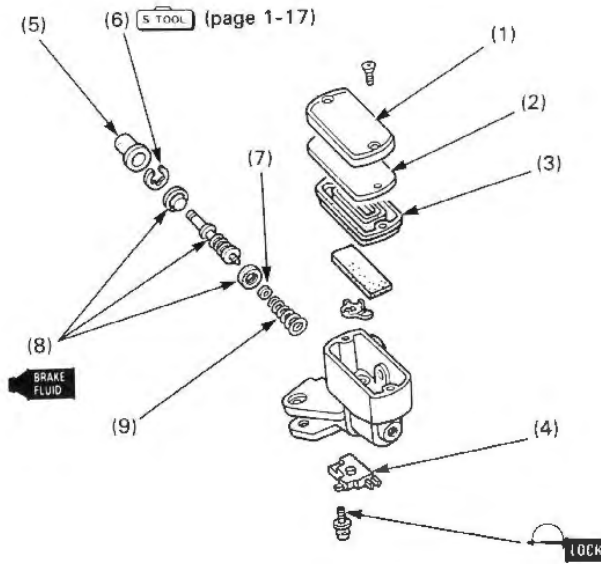

▲ WARNING

- Check the brake system by applying the brake after air bleeding.

CAUTION

- Avoid spilling fluid on painted, plastic, or rubber parts. Place a rag over these parts whenever the system is serviced.
- Do not allow the lips of the cups to turn inside out and be certain the snap ring is firmly seated in the groove.

NOTE

- The master cylinder piston, cups and spring must be installed as a set.

Procedure	Q'ty	Remarks
Disassembly Order		Assembly is in the reverse order of disassembly.
(1) Reservoir cover	1	
(2) Diaphragm plate	1	
(3) Diaphragm	1	
(4) Front brakelight switch	1	
(5) Rubber boot	1	
(6) Snap ring	1	CAUTION • Be certain the snap ring is fully seated in the groove • Install the snap ring with the chamfered side facing the master piston.
(7) Stopper plate	1	
(8) Master piston assembly	1	
(9) Spring	1	Install the spring with the tapered side facing the master piston.

Front Brake Caliper Removal/Installation

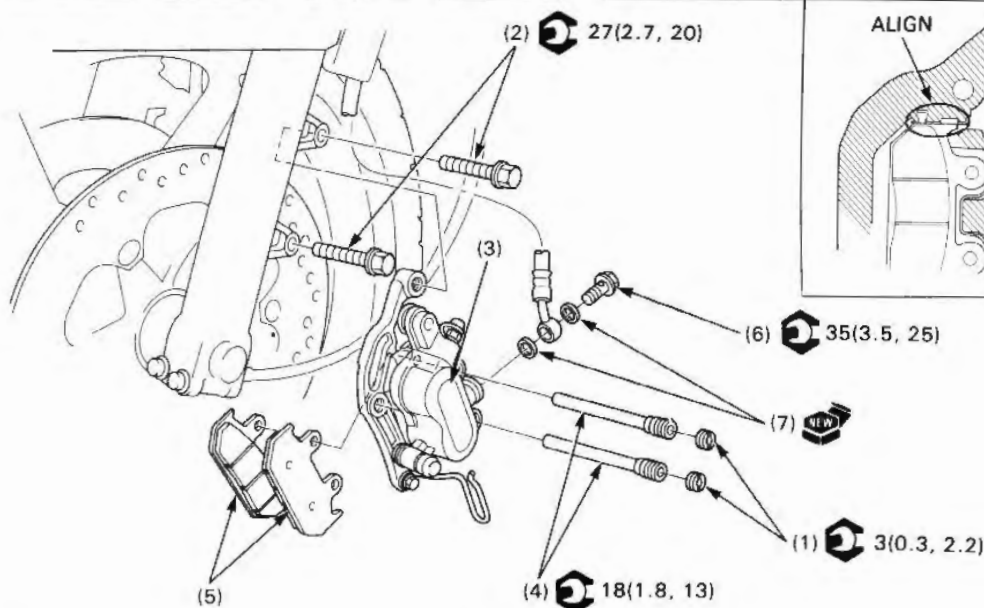
▲ WARNING

- Do not get grease on the brake disc or stopping power will be reduced.
- Discard contaminated pads and clean a contaminated disc with a high quality brake degreasing agent.
- Check the brake system by applying the brake after pad replacement.

NOTE

- Operate the brake lever to seat the caliper pistons against the pads after the pad replacement.
- Brake pad replacement can be done without disconnecting the hydraulic system.
- Always replace the brake pads in pairs to assure even disc pressure.
- If you plan to remove the front brake caliper, loosen the brake hose bolt before removing the front brake caliper from the fork slider.

Procedure		Q'ty	Remarks
Removal Order			Installation is in the reverse order of removal.
Pad replacement			
(1)	Pad pin plug	2	After removing the pad pin plugs, loosen the pad pins.
(2)	Caliper bracket bolt	2	
(3)	Front brake caliper assembly	1	
(4)	Pad pin	2	Insert the pins while pushing the pads against the pad spring.
(5)	Brake pad	2	Position the pad onto the pad retainer in the caliper as shown.
Front brake caliper removal			
(6)	Brake hose bolt	1	
(7)	Sealing washer	2	

Front Brake Caliper Disassembly/Assembly

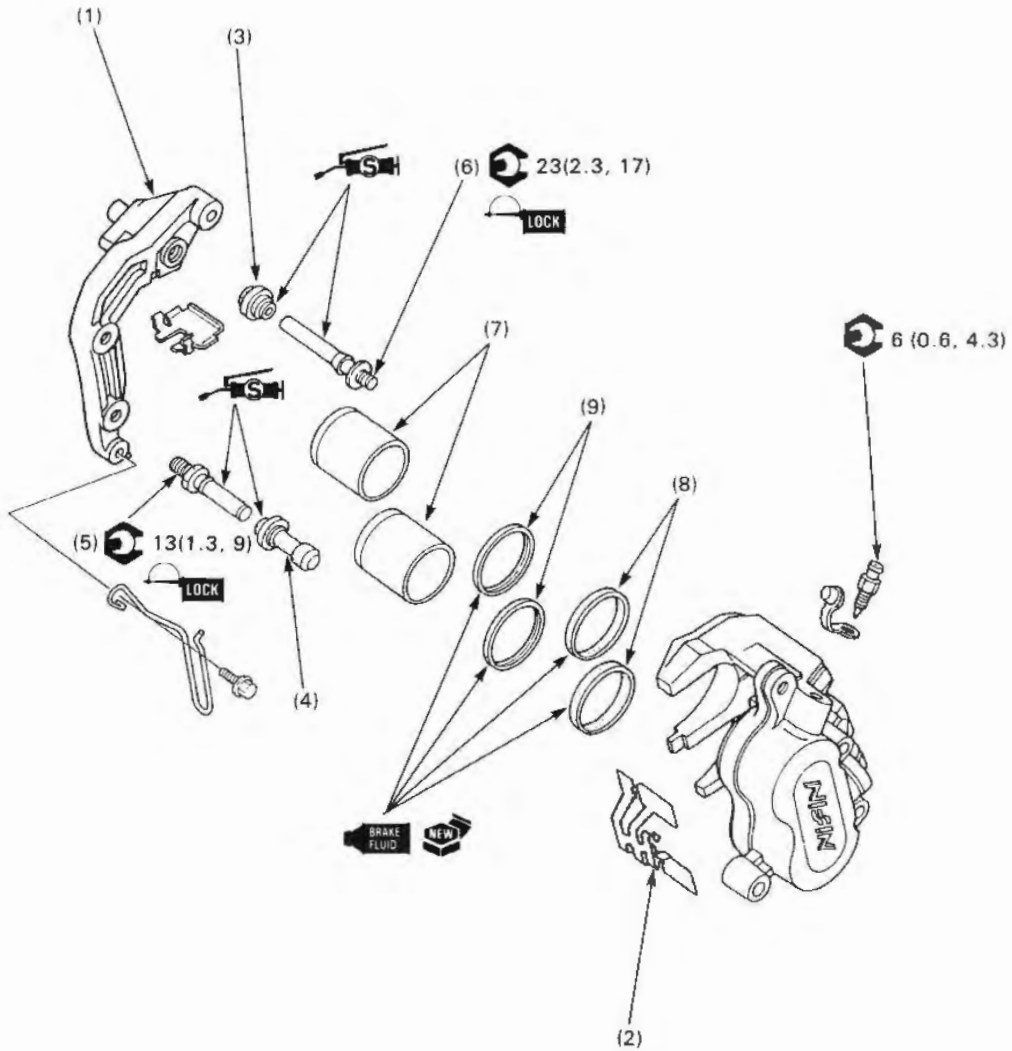

CAUTION

- Avoid spilling fluid on painted, plastic, or rubber parts. Place a rag over these parts whenever the system is serviced.

Requisite Service

- Front brake caliper removal/installation (page 14-5)

Procedure	Q'ty	Remarks
Disassembly Order		
(1) Caliper bracket	1	CAUTION Be careful not to damage the piston sliding surface when removing the seals.
(2) Pad spring	1	
(3) Bracket pin bolt boot	1	
(4) Caliper pin bolt boot	1	
(5) Bracket pin bolt	1	
(6) Caliper pin bolt	1	
(7) Caliper piston	2	
(8) Dust seal	2	
(9) Piston seal	2	
Assembly Order		
(9) Piston seal	2	Install them with the opening forward the pads. Apply a locking agent to the threads and torque it. Apply silicone grease to the sliding surface of the pin. Install the boot into the bracket groove securely.
(8) Dust seal	2	
(7) Caliper piston	2	
(6) Caliper pin bolt	1	
(5) Bracket pin bolt	1	
(4) Caliper pin bolt boot	1	
(3) Bracket pin bolt boot	1	
(2) Pad spring	1	
(1) Caliper bracket	1	

Rear Master Cylinder Removal/Installation

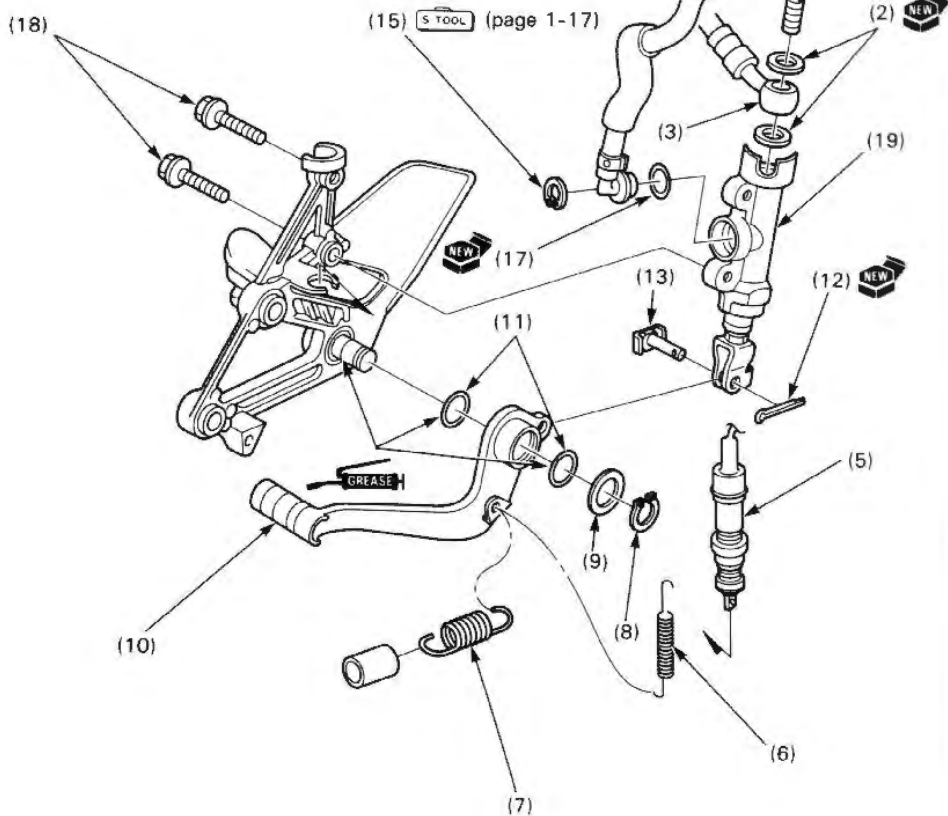
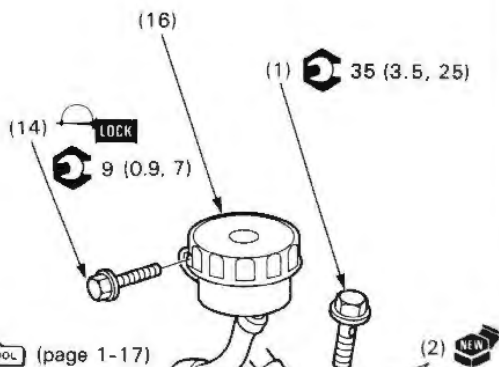
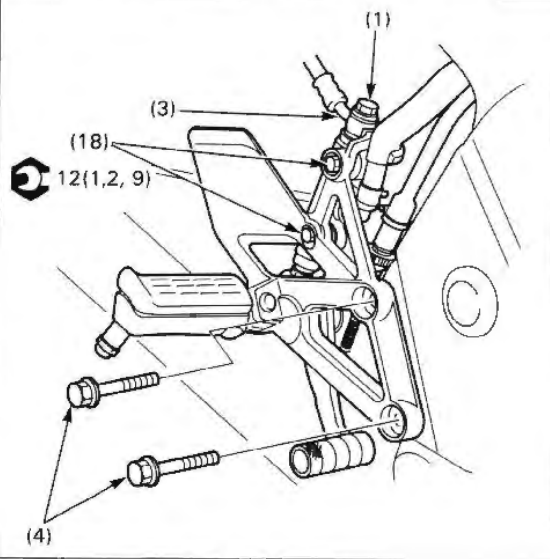

▲ WARNING

- Check the brake system by applying the brake after air bleeding.

CAUTION

- Avoid spilling fluid on painted, plastic, or rubber parts. Place a rag over these parts whenever the system is serviced.
- When removing the brake hose bolt, cover the end of the brake hose to prevent contamination.
- Do not allow foreign material to enter the system.

NOTE

- Use only DOT 4 brake fluid from a sealed container.

Requisite Service

- Right side cover removal/installation (page 2-2)
- Brakelight switch adjustment (Refer to section 2 of the Common Service Manual.)

Procedure	Q'ty	Remarks
Removal Order		Installation is in the reverse order of removal.
(1) Brake hose bolt	1	
(2) Sealing washer	2	
(3) Brake hose	1	
(4) Step holder bolt	2	Before removing, loosen the master cylinder mounting bolts.
(5) Brake light switch	1	Loosen the brake light switch adjuster fully and disconnect the spring from the switch.
(6) Brakelight switch spring	1	
(7) Brake pedal return spring	1	
(8) Snap ring	1	Install the snap ring with the chamfered side facing the brake pedal.
(9) Washer	1	
(10) Brake pedal	1	
(11) Dust seal	2	
(12) Cotter pin	1	
(13) Joint pin	1	
(14) Reservoir mounting bolt	1	
(15) Snap ring	1	Install the snap ring with the chamfered side facing in.
(16) Reservoir assembly	1	
(17) O-ring	1	
(18) Rear master cylinder mounting bolt	2	
(19) Rear master cylinder assembly	1	

Rear Master Cylinder Disassembly/Assembly

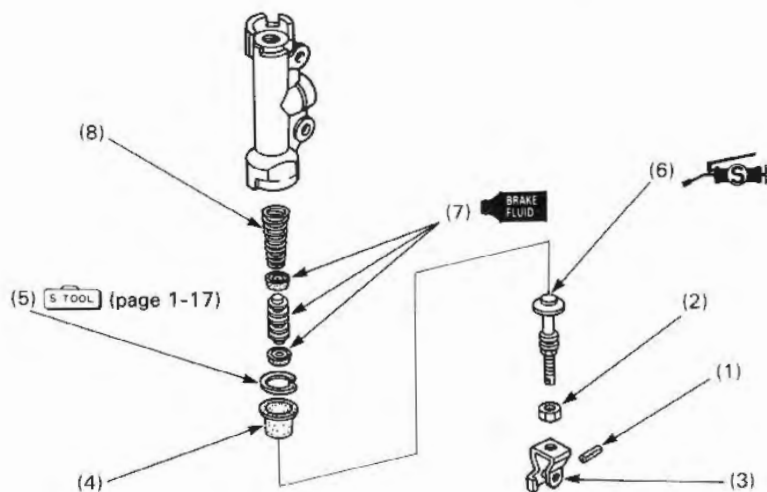

WARNING

- Check the brake system by applying the brake after air bleeding.

CAUTION

- Avoid spilling fluid on painted, plastic, or rubber parts. Place a rag over these parts whenever the system is serviced.
- Do not allow the lips of the cups to turn inside out and be certain the snap ring is firmly seated in the groove.

NOTE

- The master cylinder piston, cups and spring must be installed as a set.

Requisite Service

- Rear master cylinder removal/installation (page 14-8)

Procedure	Q'ty	Remarks
Disassembly Order		Assembly is in the reverse order of disassembly.
(1) Lock pin	1	CAUTION • Be certain the snap ring is fully seated in the groove. • Install the snap ring with the chamfered side facing the master piston.
(2) Lock nut	1	
(3) Push rod joint	1	
(4) Rubber boot	1	
(5) Snap ring	1	
(6) Push rod	1	Install the spring with the tapered side facing the master piston.
(7) Master piston assembly	1	
(8) Spring	1	

Rear Brake Caliper Removal/Installation

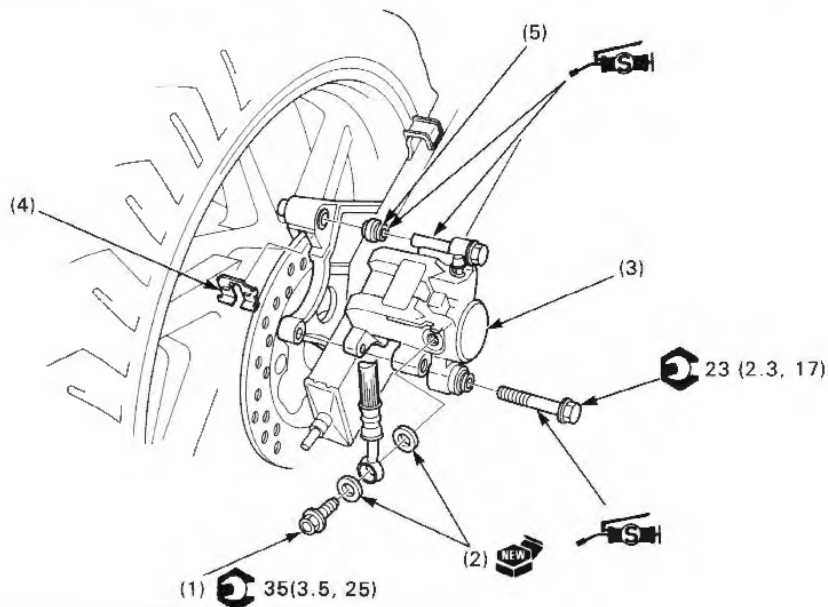

▲ WARNING

- Do not get grease on the brake disc or stopping power will be reduced.
- Discard contaminated pads and clean a contaminated disc with a high quality brake degreasing agent.
- Check the brake system by applying the brake after pad replacement.

NOTE

- Brake pad replacement can be done without disconnecting the hydraulic system.
- Always replace the brake pads in pairs to assure even disc pressure.

Requisite Service

- Rear brake pad removal/installation (page 14-2)

Procedure	Q'ty	Remarks
Removal Order		Installation is in the reverse order of removal.
(1) Brake hose bolt	1	
(2) Sealing washer	2	
(3) Rear brake caliper assembly	1	
(4) Pad retainer	1	
(5) Rubber boot	1	Install the boot into the bracket groove securely.

Rear Brake Caliper Disassembly/Assembly

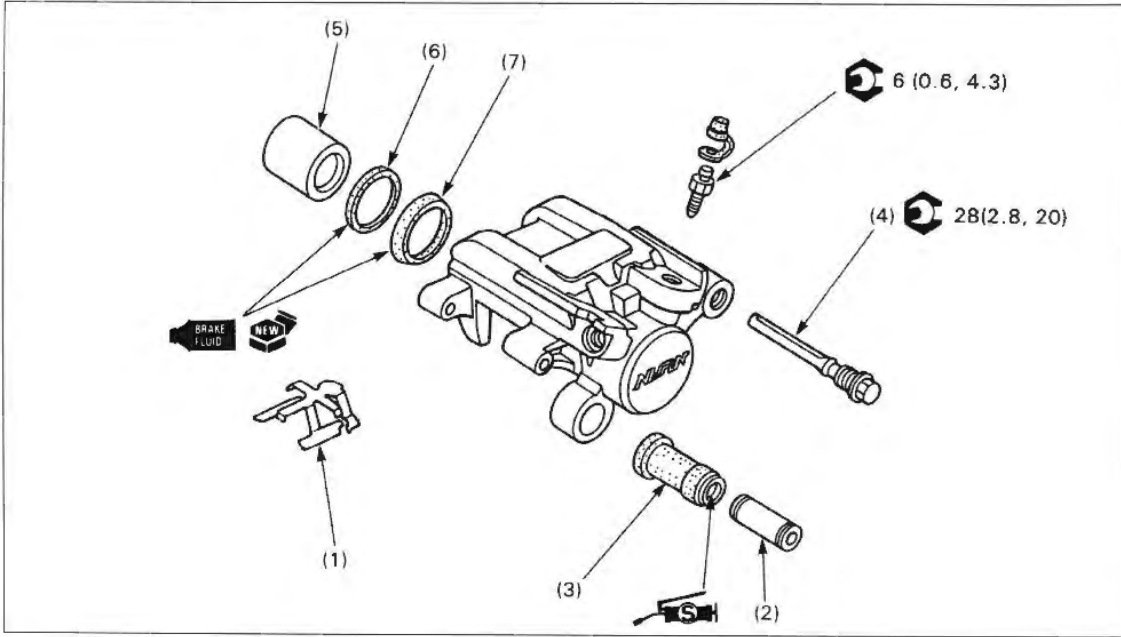

CAUTION

- Avoid spilling fluid on painted, plastic, or rubber parts. Place a rag over these parts whenever the system is serviced.

Requisite Service

- Rear brake caliper removal/installation (page 14-11)

Procedure	Q'ty	Remarks
Disassembly Order		Assembly is in the reverse order of disassembly.
(1) Pad spring	1	
(2) Pivot collar	1	
(3) Piston boot	1	
(4) Caliper pin bolt	1	Apply a locking agent to the threads and torque it. Apply silicone grease to the sliding surface of the pin.
(5) Caliper piston	1	Install the piston with the opening toward the pads.
(6) Dust seal	1	CAUTION • Be careful not to damage the piston sliding surface when removing the seals.
(7) Piston seal	1	

15. Charging System/Alternator

Service Information	15-1	Charging System Inspection	15-6
System Location	15-2	Regulator/Rectifier	15-7
Circuit Diagram	15-2	Alternator Removal/Installation	15-8
Troubleshooting	15-3	Flywheel Removal/Installation	15-9
Battery Removal/Installation	15-4	Charging Coil Inspection	15-11

Service Information

WARNING

- The battery gives off explosive gasses ; keep sparks, flames, and cigarettes away. Provide adequate ventilation when charging or using the battery in an enclosed space.
 - The battery contains sulfuric acid (electrolyte). Contact with skin or eyes may cause severe burns. Wear protective clothing and a face shield.
 - If electrolyte gets on your skin, flush with water.
 - If electrolyte gets in your eyes, flush with water for at least 15 minutes and call a physician immediately.
 - Electrolyte is poisonous. If swallowed, drink large quantities of water or milk and follow with milk of magnesia or vegetable oil and call a physician.
 - **KEEP OUT OF REACH OF CHILDREN.**
- Always turn off the ignition switch before disconnecting any electrical component.

CAUTION

- **Some electrical components may be damaged if terminals or connectors are connected or disconnected while the ignition switch is ON and current is present.**
- For extended storage, remove the battery, give it a full charge, and store it in a cool, dry place.
- For battery remaining in a stored motorcycle, disconnect the negative battery cable from the battery terminal.

NOTE

- The maintenance free battery must be replaced when it reaches the end of its service life.

CAUTION

- **The battery caps should not be removed. Attempting to remove the sealing caps from the cells may damage the battery.**
- Battery can be damaged if overcharged or undercharged, or if left to discharge for long periods. These same conditions contribute to shortening the "life span" of the battery. Even under normal use, the performance of battery deteriorates after 2-3 years.
- Battery voltage may recover after battery charging, but under heavy load, battery voltage will drop quickly and eventually die out. For this reason, the charging system is often suspected to be the problem. Battery overcharge often results from problems in the battery itself. If one of the battery cells shorted and battery voltage does not increase, the regulator/rectifier supplies excess voltage to the battery. Under these conditions, the electrolyte level goes down quickly.
- Before troubleshooting the charging system, check for proper use and maintenance of the battery. Check if the battery is frequently under heavy load, such as having the headlight and taillight ON for long periods of time without riding the motorcycle.
- The battery will self-discharge when the motorcycle is not in use. For this reason, charge the battery every two weeks to prevent sulfation from forming.
- Filling a new battery with electrolyte will produce some voltage, but in order to achieve its maximum performance, always charge the battery. Also, the battery life is lengthened when it is initial-charged.
- When checking the charging system, always follow the steps in the troubleshooting flow chart (page 15-3).
- For battery testing/charging, refer to section 22 of the Common Service Manual.
- For charging system location, see page 15-2.

System Location

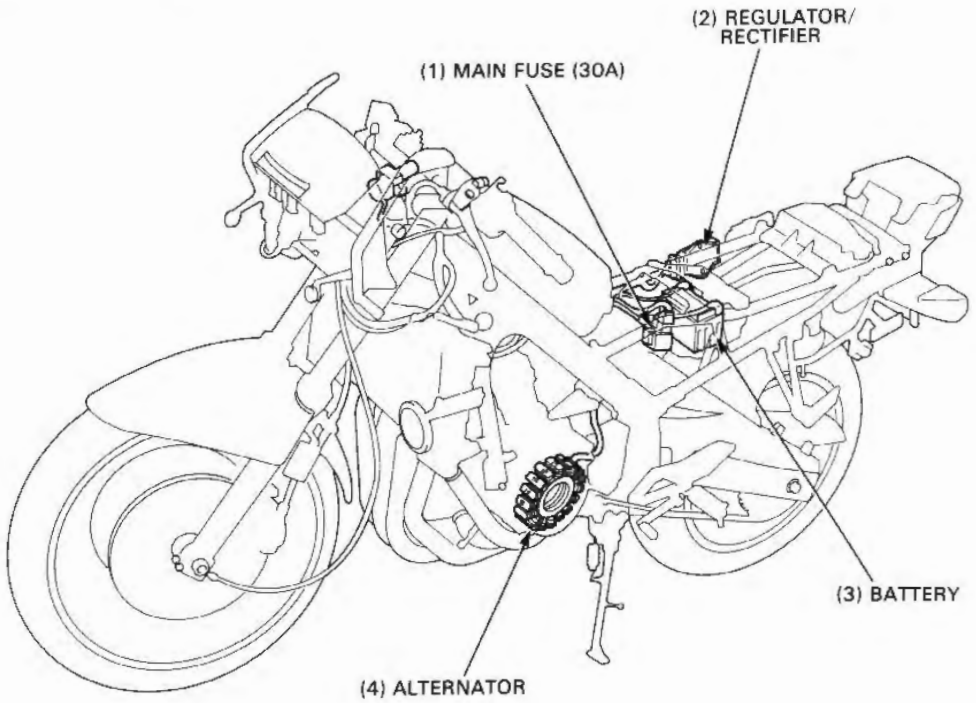

Circuit Diagram

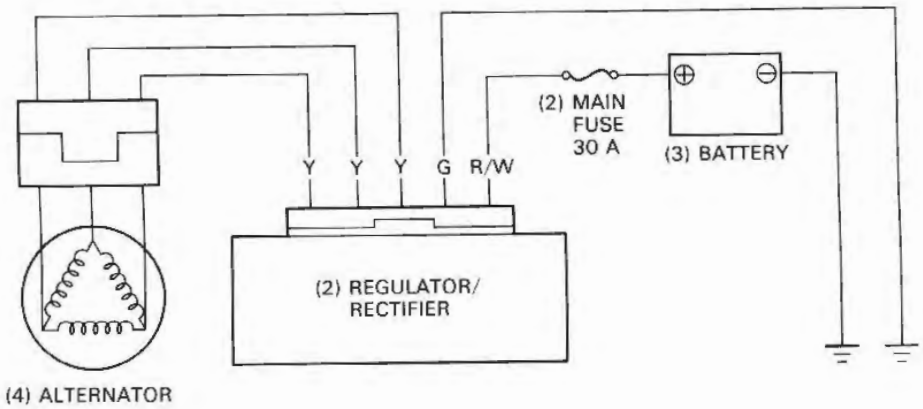

Troubleshooting

Battery overcharging

- Faulty regulator/rectifier

Battery undercharging

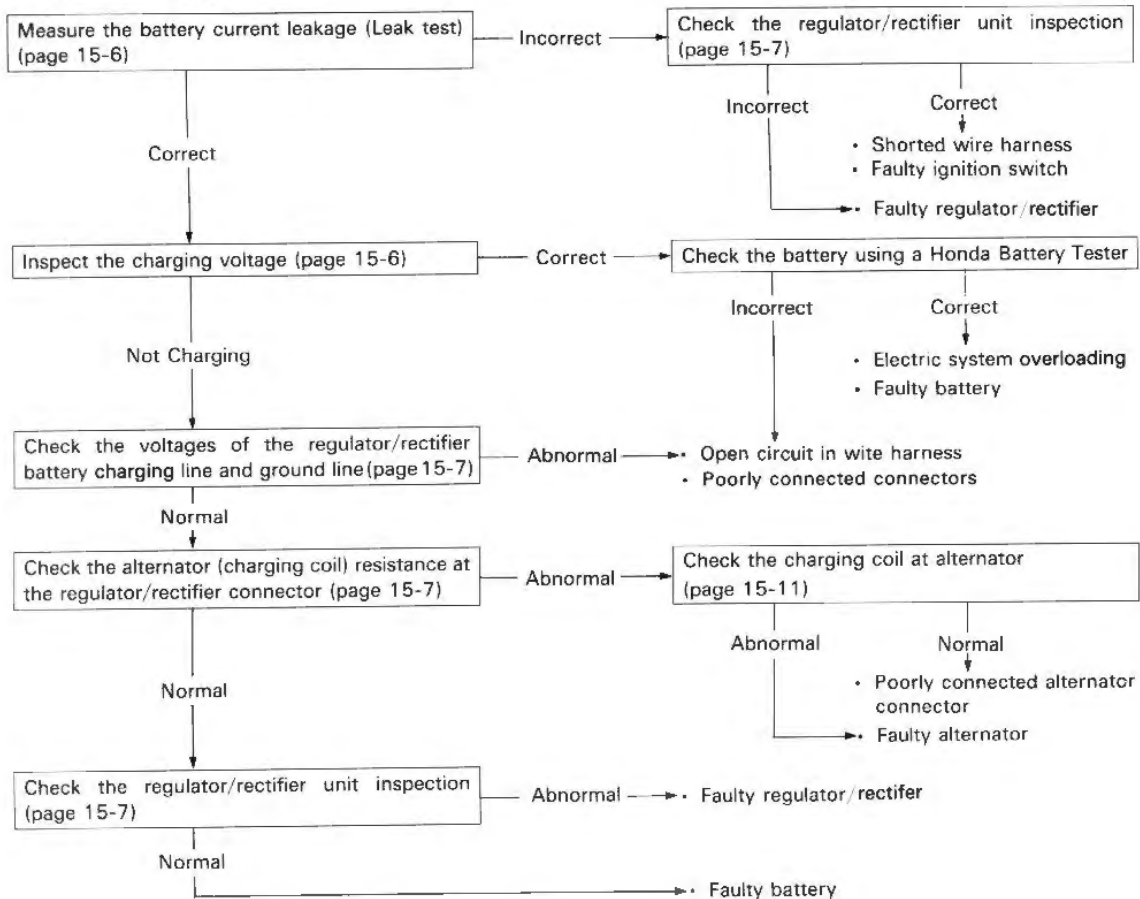

Battery Removal/Installation

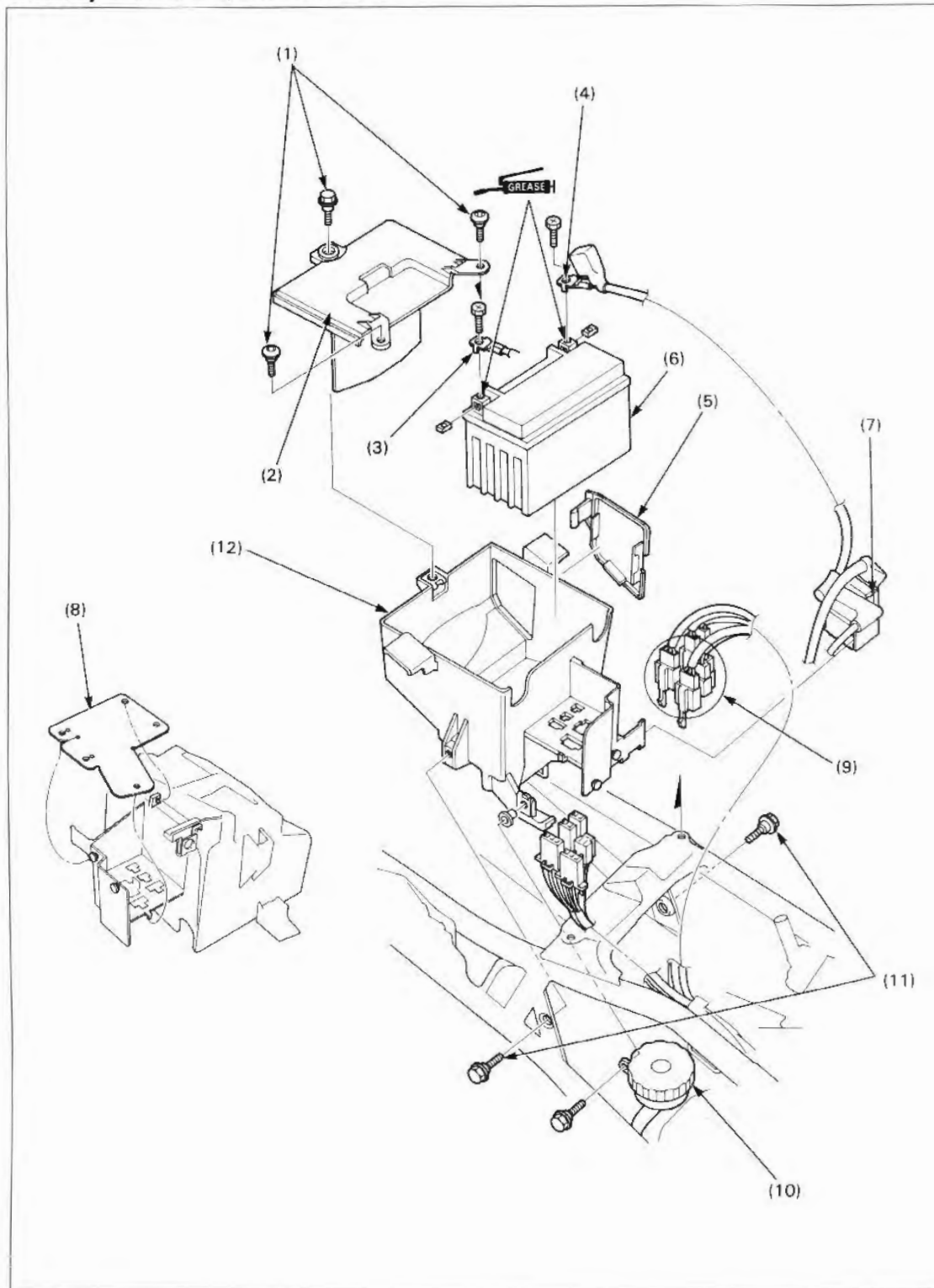

Requisite Service

• Side cover removal/installation (page 2-2)

• Seat removal/installation (page 2-2)

Procedure		Q'ty	Remarks
Removal Order			
(1)	Flange bolt/Socket bolt	1/2	Installation is in the reverse order of removal.
(2)	Battery case cover	1	
(3)	Battery negative (-) cable	1	
(4)	Battery positive (+) cable	1	
(5)	Tool case lid	1	
(6)	Battery	1	
(7)	Starter relay switch	1	When installing the rubber cover, align the holes in the cover with the hooks on the battery case.
(8)	Rubber cover	1	
(9)	Connector	5	
(10)	Rear master cylinder reservoir	1	
(11)	Bolt	2	
(12)	Battery case	1	

Charging System Inspection

Leak Test

Turn off the ignition switch, and disconnect the ground (-) cable from the battery.

Connect the ammeter (+) probe to the ground cable and the ammeter (-) probe to the battery (-) terminal.

With the ignition switch off, measure the leakage current.

NOTE

- When measuring current using a tester, set a high range, and then bring the range down to an appropriate level. Current flow larger than the range selected may blow out the fuse in the tester.
- While measuring current, do not turn the ignition on. A sudden surge of current may blow out the fuse in the tester.

Specified current leakage : 1.2 mA max.

If current leakage exceeds the specified value, a shorted circuit is likely. Locate the short by disconnecting connections one by one and measure the current.

Charging Voltage Inspection

NOTE

- Before performing this test, be sure that the battery is fully charged whose voltage between its terminals is greater than 12.8 V.

Start the engine and warm it up to operating temperature, then turn the ignition switch off.

Connect a multimeter between the battery terminals.

5 TOOL

Digital multimeter

07411-0020000

Disconnect the starter relay switch connector and remove the main fuse (30 A). Reconnect the connector onto the relay switch.

Connect the ammeter as shown.

CAUTION

- Be careful not to short any tester probes.
- Although the current could be measured when the ammeter is connected between the battery positive terminal and the positive cable, a sudden surge of current to the starter motor could damage the ammeter.
- Always turn the ignition off when conducting the test. Disconnecting the ammeter or wires when current is flowing may damage the ammeter.

Start the engine and increase the engine speed gradually.

Regulated voltage : 13.0-15.5V/5,000min⁻¹(rpm)

Charging current : 1A MAX/5,000 min⁻¹(rpm)

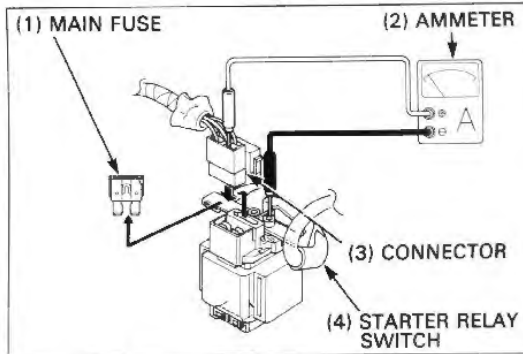
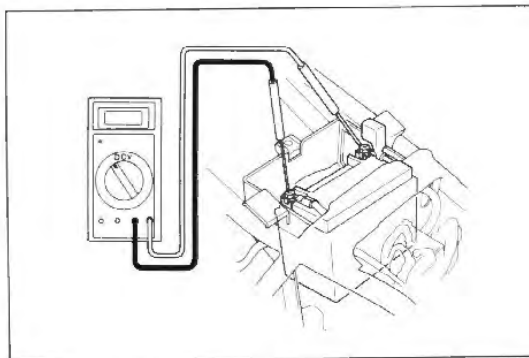
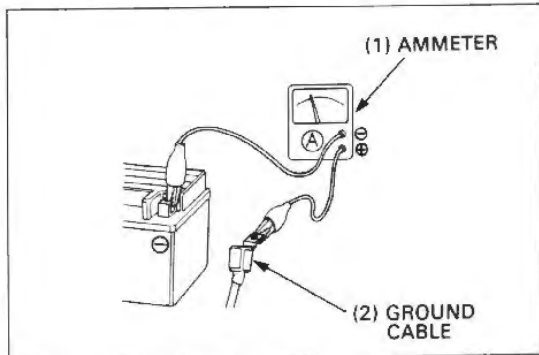

Regulator/Rectifier

Wire Harness Inspection

Remove the right side cover (page 2-2)

Disconnect the regulator/rectifier connector and measure the following between rectifier connector terminals of the wire harness side.

Item	Terminals	Specification
Battery charging line	Red/White (+) and ground (-)	Battery voltage should register.
Ground line	Green and ground	Continuity exist.
Charging coil line	Yellow and Yellow	0.1-1.0Ω (20° C/68° F)

Unit Inspection

Disconnect the regulator/rectifier connector and remove the bolts and regulator/rectifier.

Inspect the regulator/rectifier unit by measuring the resistance between the terminals.

NOTE

- You'll get false readings if you touch the probes with your finger.
- Use the specified multimeter. Using other equipment may not allow you to obtain the correct values. This is due to the characteristic of semiconductors, which have different resistance value depending on the applied voltage.

Specific Multimeter:

- 07411-0020000 (KOWA Digital type)
- 07308-0020001 (SANWA Analogue type)
- TH-5H (KOWA Analogue type)

- Select the following range.
SANWA tester: × kΩ
KOWA tester: × 100Ω
- When using the KOWA multimeter, remember that all readings should be multiplied by 100.
- An old battery stored in the multimeter could cause inaccurate readings. Check the battery if the multimeter registers incorrectly.

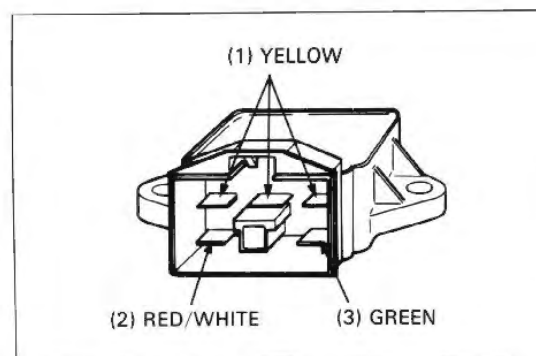
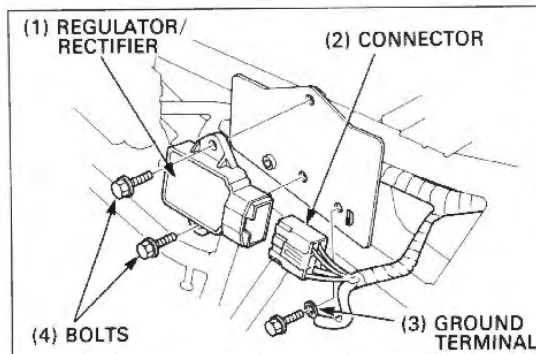
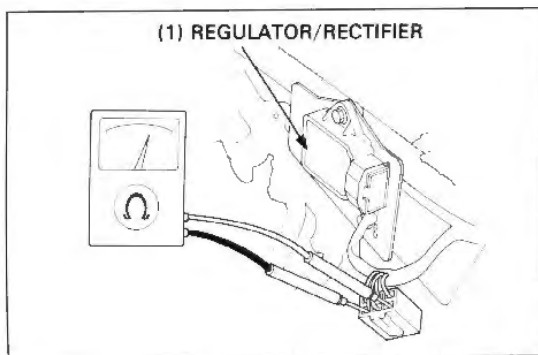

Replace the regulator/rectifier unit if the resistance value between the terminals is abnormal.

Install the regulator/rectifier in the reverse order of removal.

Unit:kΩ

	+	Red/White	Yellow 1	Yellow 2	Yellow 3	Green
Red/White	-		∞	∞	∞	∞
Yellow 1		0.5-10		30-500	30-500	10-200
Yellow 2		0.5-10	30-500		30-500	10-200
Yellow 3		0.5-10	30-500	30-500		10-200
Green		1-20	0.5-10	0.5-10	0.5-10	

Alternator Removal/Installation

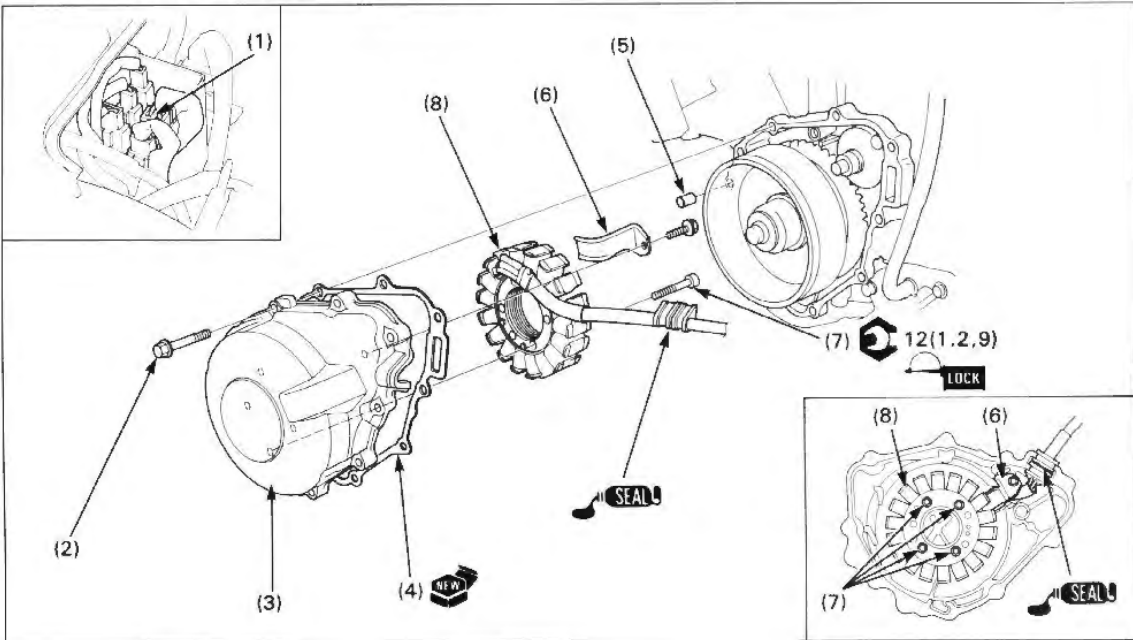

Requisite Service

- Fuel tank removal/installation (page 2-11)
- Right side fairing removal/installation (page 2-3)

Procedure		Q'ty	Remarks
Removal Order			Installation is in the reverse order of removal.
(1)	Alternator connector	1	
(2)	Left crankcase cover bolt (long/short)	9/1	
(3)	Left crankcase cover	1	
(4)	Gasket	1	
(5)	Dowel pin	1	
(6)	Stator wire holder	1	When installing, apply sealant to the grommet and install the grommet securely into the groove in the left crankcase cover.
(7)	Stator bolt	4	
(8)	Stator	1	

Flywheel Removal/Installation

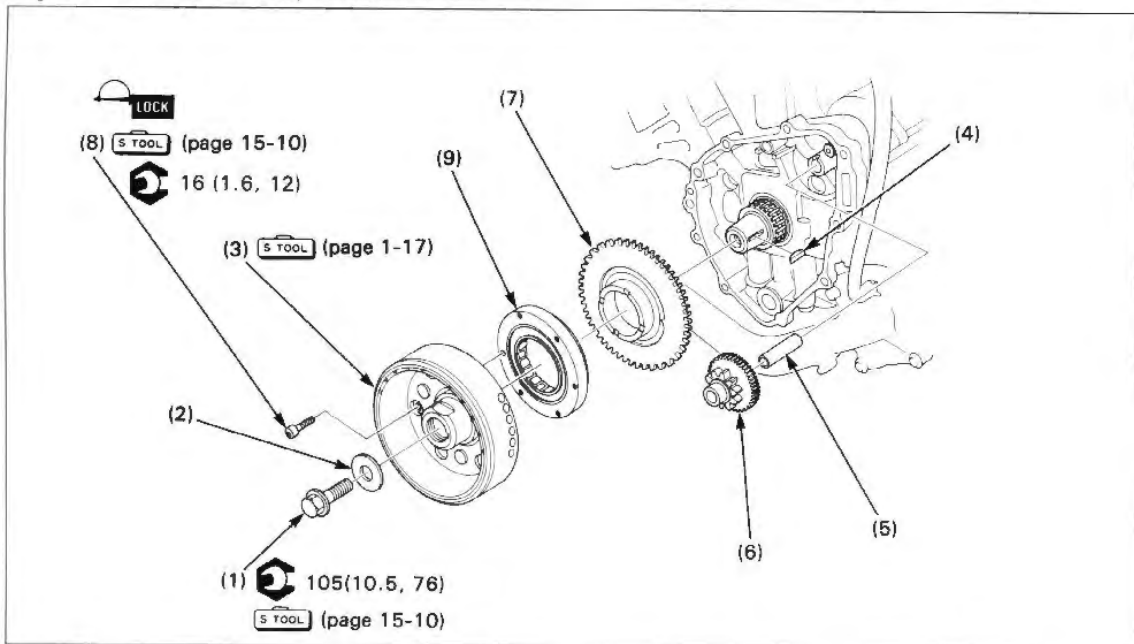

Requisite Service

- Alternator cover removal/installation (page 15-8)

Procedure		Q'ty	Remarks
	Removal Order		
(1)	Flywheel bolt	1	Installation is in the reverse order of removal. Refer to page 15-10 for removal and installation.
(2)	Washer	1	
(3)	Flywheel	1	
(4)	Woodruff key	1	Before installing, wipe any oil off the mating surfaces of the crankshaft and flywheel.
(5)	Starter idle gear shaft	1	
(6)	Starter idle gear	1	
(7)	Starter driven gear	1	Remove and install the starter driven gear turning it counterclockwise.
(8)	Starter clutch bolt	6	Refer to page 15-10 for removal and installation.
(9)	Starter clutch	1	

Flywheel Bolt Removal/Installation

Loosen the flywheel bolt while holding the flywheel with a flywheel holder.

S TOOL

Flywheel holder

07925-ME90000 or equivalent commercially available in U.S.A.

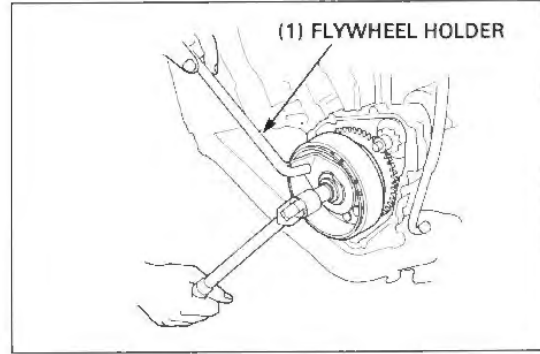

Tighten the flywheel bolt while holding the flywheel with a flywheel holder.

Torque : 105 N · m (10.5 kg-m, 76 ft-lb)

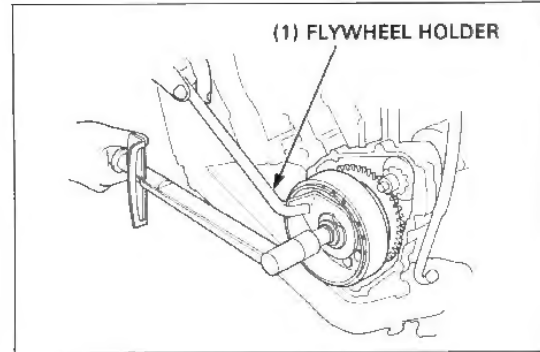

Starter Clutch Bolt Removal/Installation

Remove the starter clutch bolts while holding the flywheel with a flywheel holder.

S TOOL

Flywheel holder

Torx bit (T30)

07725-0040000 or 07703-0010200 equivalent commercially available

Remove the starter clutch.

After removing the starter clutch bolts, clean the locking agent residue off the starter clutch bolts.

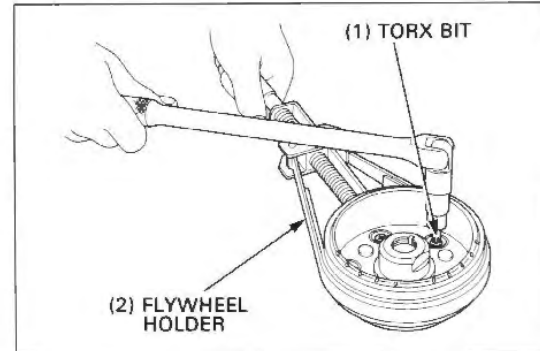

Apply a locking agent to the threads of the starter clutch bolts, and tighten them to the specified torque while holding the flywheel with a flywheel holder.

Torque : 16 N · m (1.6 kg-m, 12 ft-lb)

Install the starter driven gear to the flywheel while turning the starter driven gear counterclockwise.

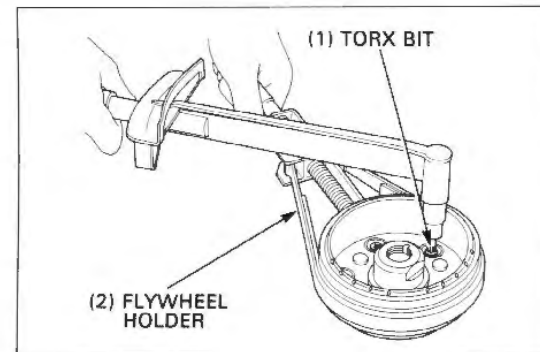

Charging Coil Inspection

NOTE

- It is not necessary to remove the alternator from the engine for this inspection.

Remove the seat (page 2-2).

Disconnect the alternator 3P connector and measure the resistance between the connector terminals (Yellow and Yellow).

Standard : 0.1-1.0 Ω (20° C / 68° F)

Check for continuity between the Yellow wire terminal and ground.

There should be no continuity.

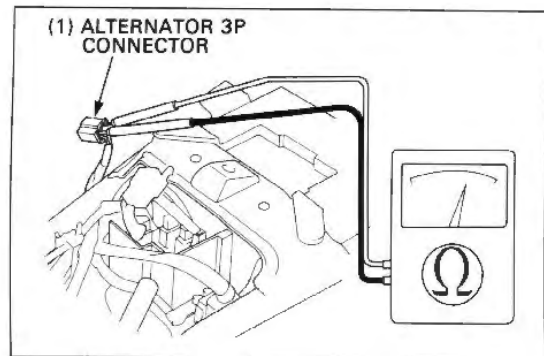

16. Ignition System

Service Information	16-1	Ignition Coil Inspection	16-7
System Location	16-2	Ignition Coil Removal/Installation	16-8
Circuit Diagram	16-2	Ignition Pulse Generator	16-9
Troubleshooting	16-3	Ignition Timing	16-9
Ignition System Inspection	16-6	Ignition Pulse Generator Rotor Cover Removal/Installation	16-10

Service Information

- When checking the ignition system, always follow the steps in the troubleshooting flow chart (see page 16-3).
- Perform a spark test at each cylinder before troubleshooting.
- A loose connection is often the cause of the ignition problems. Check all connections before troubleshooting.
- Make sure battery is adequately charged. Using the starter motor with a weak battery results in a slower engine cranking speed as well as a weak spark at the plugs.
- This ignition system includes an ignition cut-off side stand switch. The system should operate whenever:
 - the side stand is retracted
 - the transmission is in neutral
 - both conditions above exist
- For side stand switch system instructions, see page 16-4 "NOTE" of the troubleshooting.
- The transistorized ignition system uses an electrically controlled ignition timing system. No adjustment can be made to the ignition timing.
- A rough diagnosis can be made by identifying the cylinder whose spark timing is incorrect.
- Use spark plugs of the correct heat range. Using spark plugs with an incorrect heat range can damage the engine.
- For the ignition switch, engine stop switch, neutral switch and side stand switch inspection, check for continuity on the continuity chart of the Wiring Diagram, section 19. Disconnect each connector behind the instruments (page 1-20) and check it.

System Location

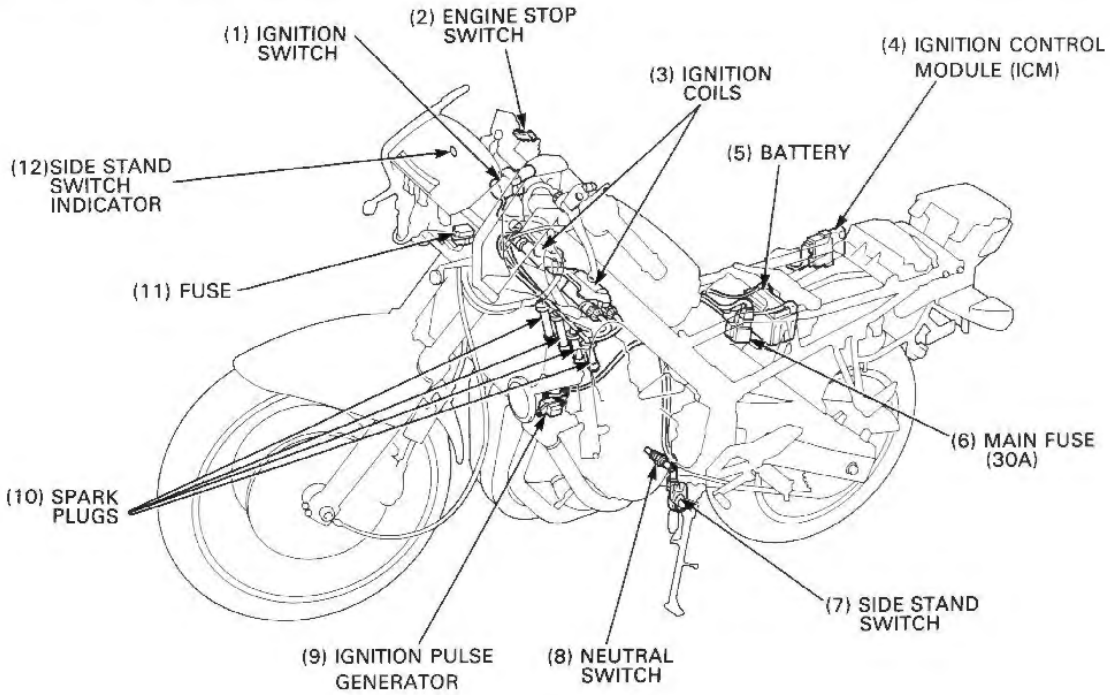

Circuit Diagram

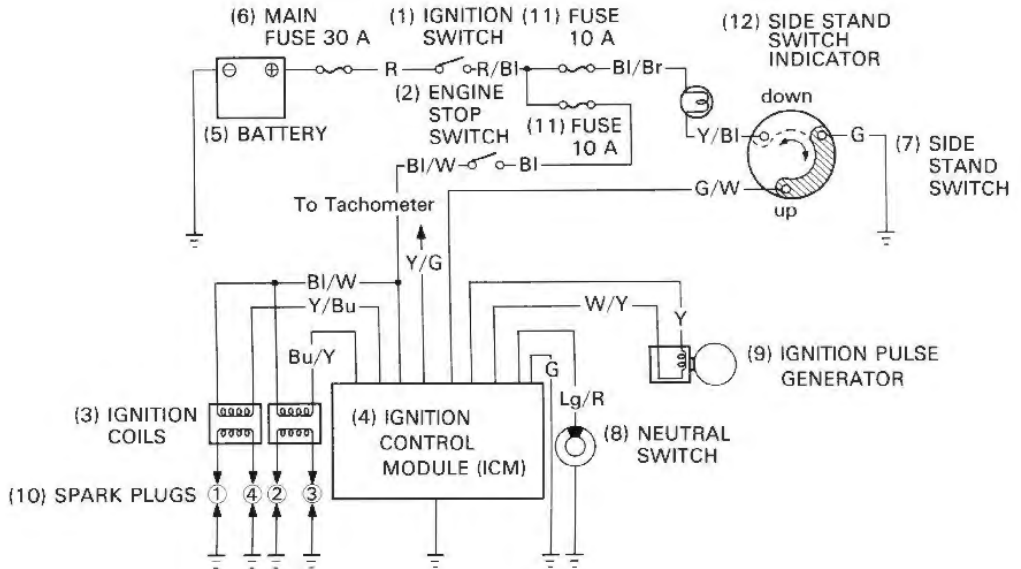

Troubleshooting

No spark at all plugs (Faulty input system)

- If there is no spark at all plugs, the problem could be at the input of the ignition system (ignition pulse generator, power input circuit of the ignition control module (ICM), neutral switch, side stand switch or ignition control module (ICM)).

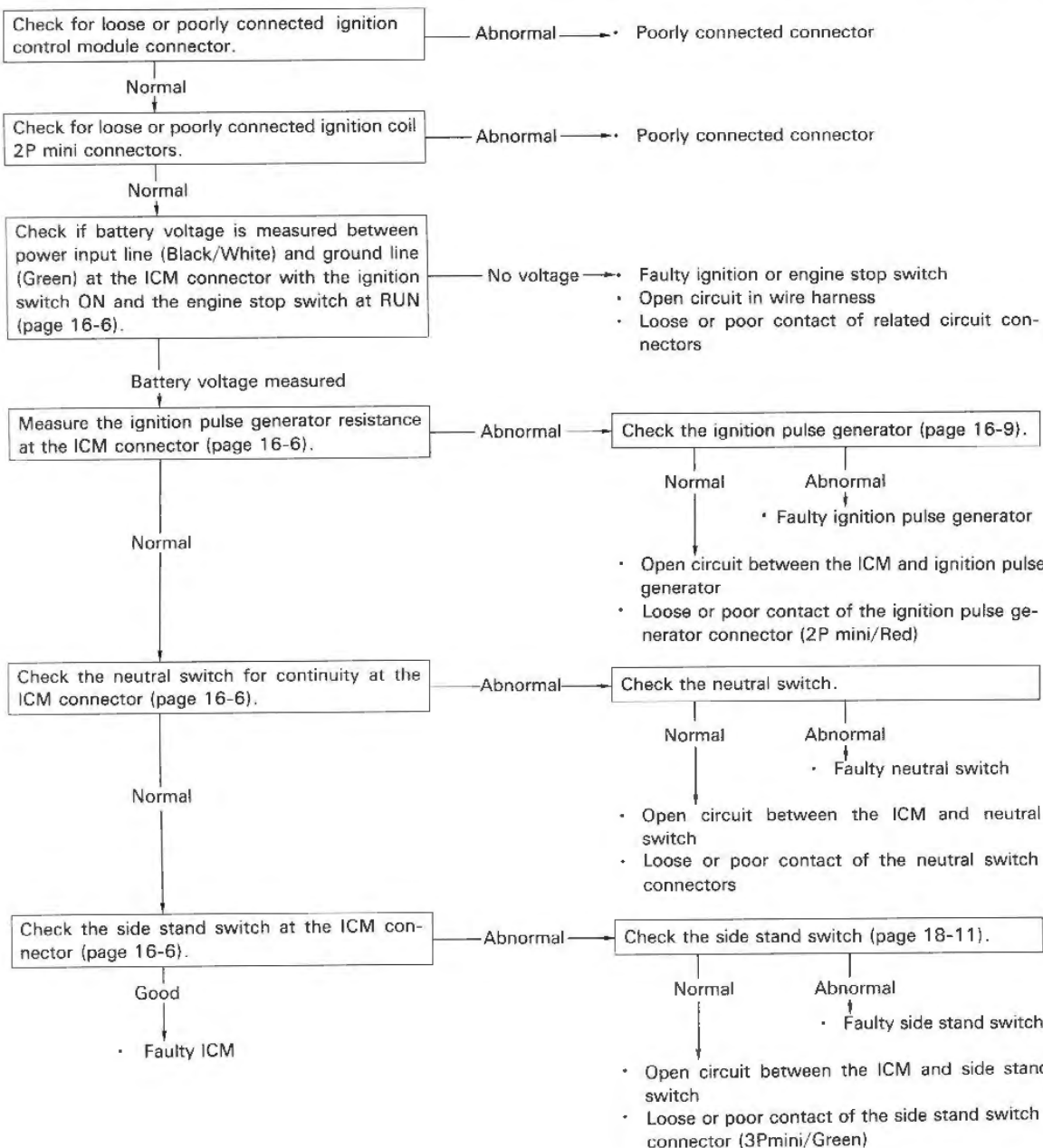

No spark at either ignition group

- If there is no spark at either group, the problem is suspected in the primary coil side of the ignition system (ignition coil, or ignition control module and ignition coil circuit).

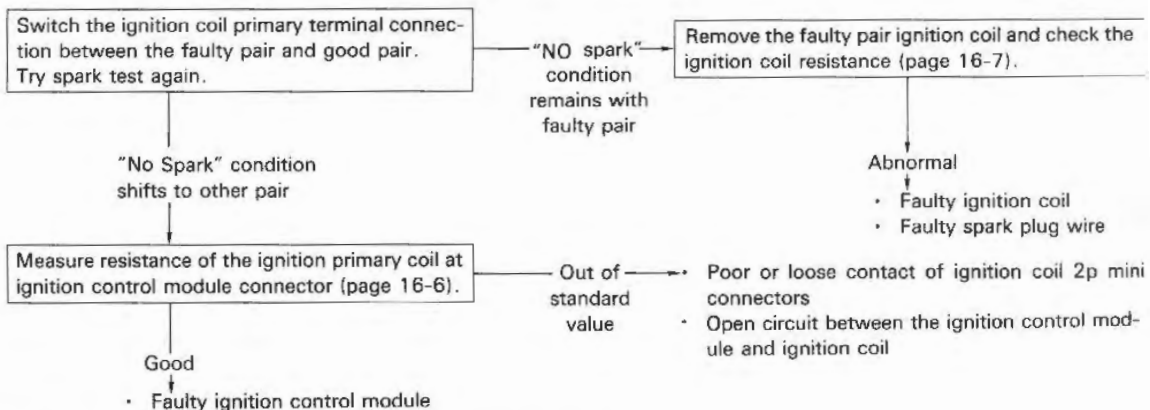

No spark at one plug (Trouble in secondary coil side)

- Faulty spark plug is most likely.

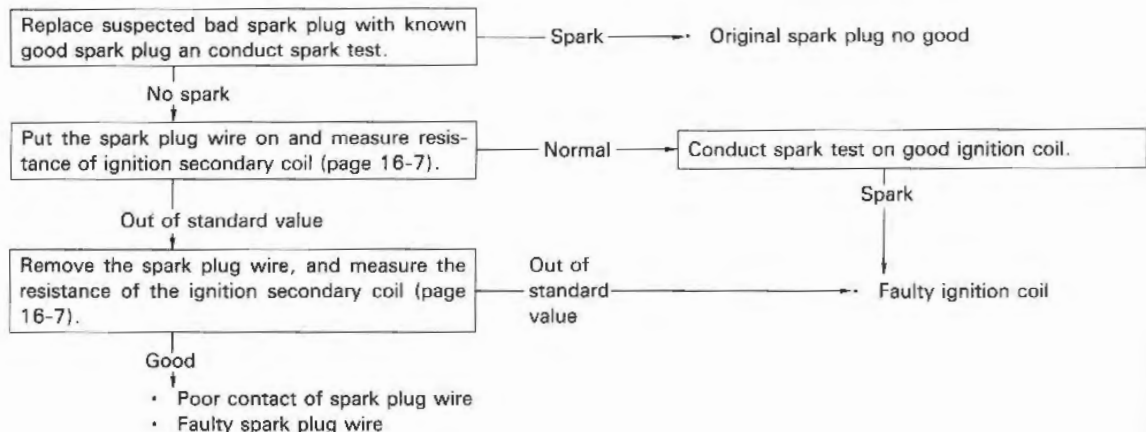

Engine starts, but the side stand switch does not function

NOTE

The side stand switch should function as follows :

- When the transmission is shifted into a gear from neutral with the side stand down, the ignition shuts off and the engine will stop.
- With the transmission in neutral, the neutral switch line (a) of the ignition control module is connected to ground via the side stand switch.

When the side stand is up, the side stand switch line (b) of the ignition control module passes to ground via the side stand switch. The ignition control module monitors lines (a) and (b), and provides spark only when one or both of those is connected to ground via the neutral switch or the side stand switch.

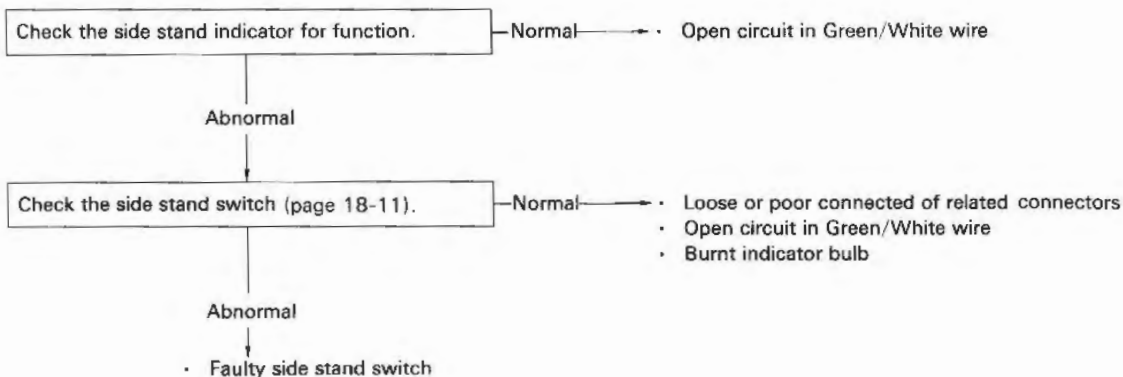

Ignition System Inspection

Circuit Inspection

NOTE

- Follow the steps in the troubleshooting flow chart for servicing.

Remove the right side cover (page 2-2).
Disconnect the ignition control module connector and conduct these tests at the connector.

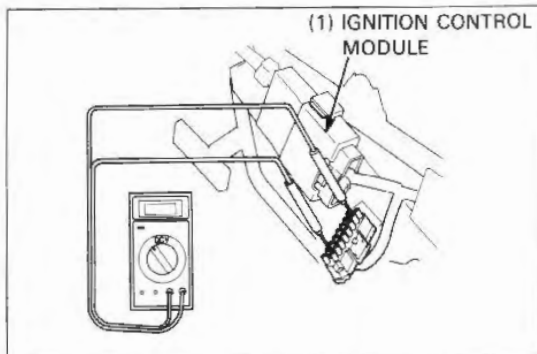

Item	Terminals	Specification
Power source input line	Black/White (+) and ground (-)	Battery voltage should register with the ignition switch ON and the engine stop switch at RUN.
Ignition pulse generator coil	Yellow and White/Yellow	460-580Ω (20°C/68°F)
Ignition primary coil	No. 1-4: Black/White and Yellow/Blue	2.5-3.1Ω (20°C/68°F)
Neutral switch line	Light green and ground	Continuity in neutral No continuity in any gear except neutral
Side stand switch line	Green/White and ground	Continuity with the side stand retracted No continuity with the side stand down
Ground line	Green	Continuity

Ignition Coil Inspection

Remove the following :

- maintenance lid (page 2-3)
- air cleaner case (page 6-3)

Measure each primary coil resistance at terminals.

Standard : 2.5-3.1 Ω (20°C/68°F)

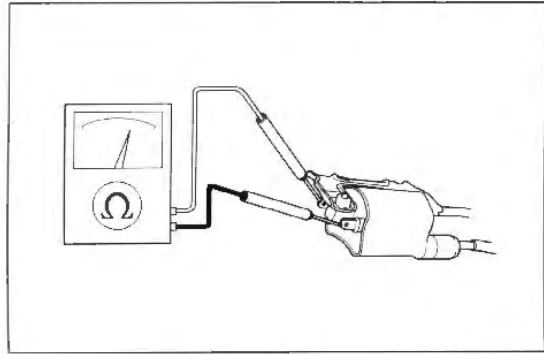

Disconnect the spark plug caps from the plugs and measure the secondary coil resistance between the spark plug caps.

Standard : 21-25k Ω (20°C/68°F)

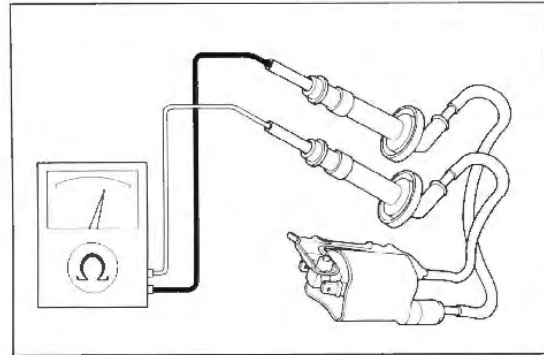

If the resistance is out of range, remove the spark plug cap. from the spark plug wire and measure the resistance as shown.

Standard : 11-15k Ω (20°C/68°F)

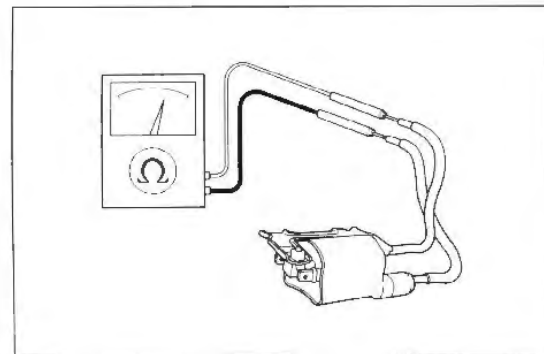

Ignition Coil Removal/Installation

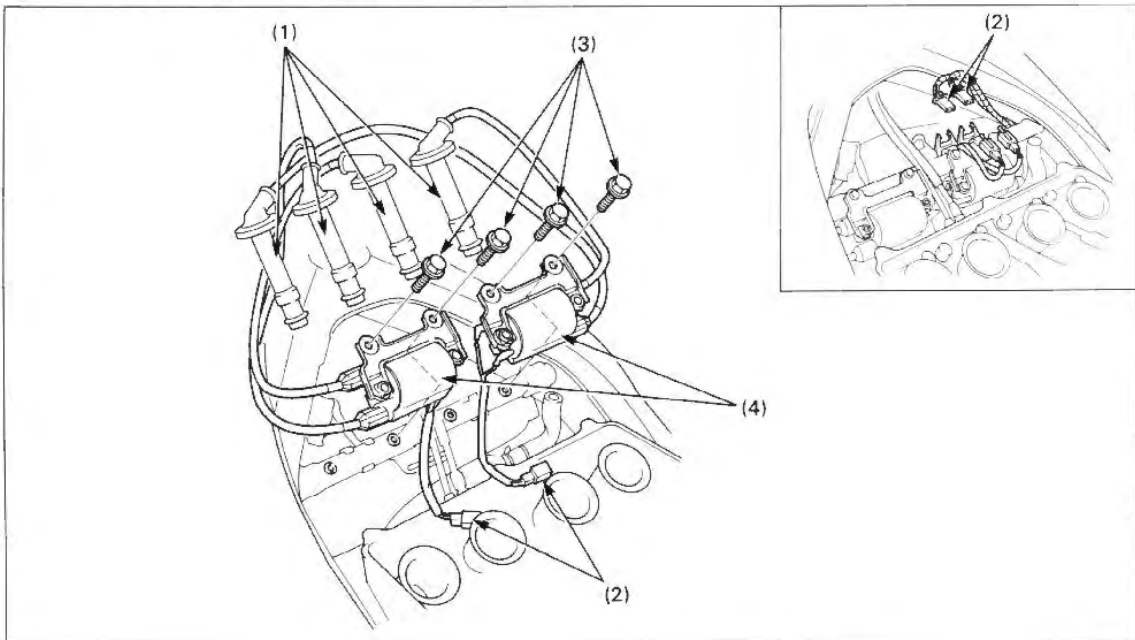

Requisite Service

• Maintenance lid removal/installation (page 2-3)

• Air cleaner housing removal/installation (page 6-3)

Procedure		Q'ty	Remarks
Removal Order			
(1)	Spark plug cap	4	Installation is in the reverse order of removal. The cylinder numbers are printed on each high tension cord. Install each spark plug cap on the correct cylinder.
(2)	Ignition coil connector	4	
(3)	Ignition coil mounting bolt	4	
(4)	Ignition coil	2	

Ignition Pulse Generator

Inspection

NOTE

- It is not necessary to remove the ignition pulse generator from the engine to make this inspection.

Remove the fuel tank (page 2-11).

Disconnect the ignition pulse generator 2P mini connector (red) and measure the resistance between White/Yellow-Yellow terminals.

Standard : 460-580 Ω (20° C/68° F)

Refer to page 16-10 for pulse ignition generator replacement.

(1) IGNITION PULSE GENERATOR CONNECTOR

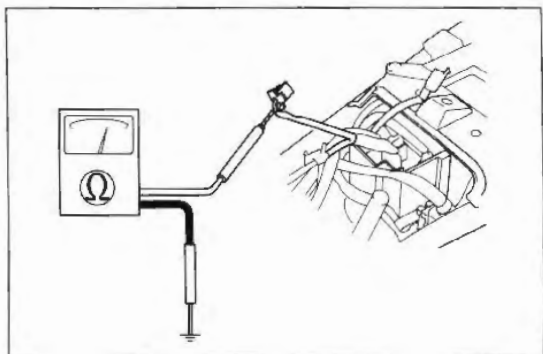
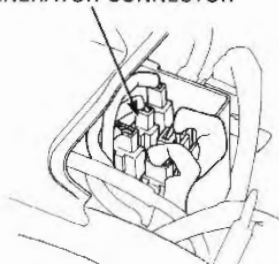

Ignition Timing

Warm up the engine.

Stop the engine and connect a timing light to the spark plug wire.

NOTE

- Read the manufacturer's instructions for the timing light before operating.

Remove the following :

- Right side fairing (page 2-3)
- Ignition pulse generator rotor cover cap.

Start the engine and let it idle.

49-State and Canada type:

The timing is correct if the F mark (notch mark) aligns with the index mark on the ignition pulse generator rotor cover.

Increase the engine speed by rotating the throttle stop screw and make sure the F mark begins to move counterclockwise at approximately 1,600 rpm.

California type:

The timing is correct if the F mark (punch marks) aligns with the index mark on the ignition pulse generator rotor cover.

Increase the engine speed by rotating the throttle stop screw and make sure the F mark begins to move counterclockwise at approximately 1,900 rpm.

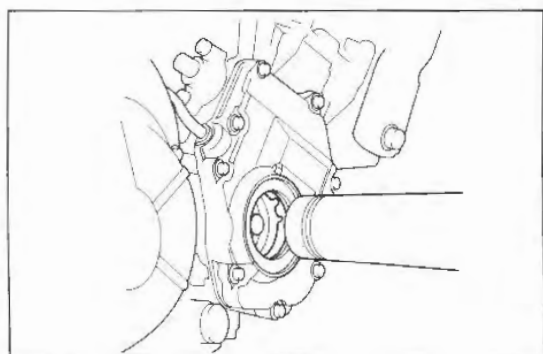

49-STATE AND CANADA
(1) INDEX MARK

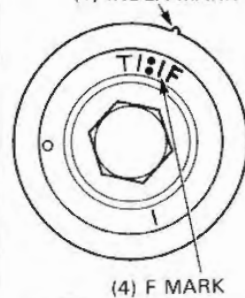

(4) F MARK

CALIFORNIA
(2) INDEX MARK

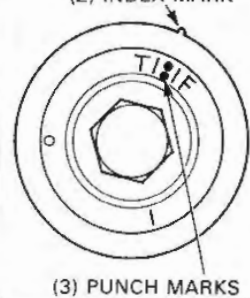

(3) PUNCH MARKS

Ignition Pulse Generator Rotor Cover Removal/Installation

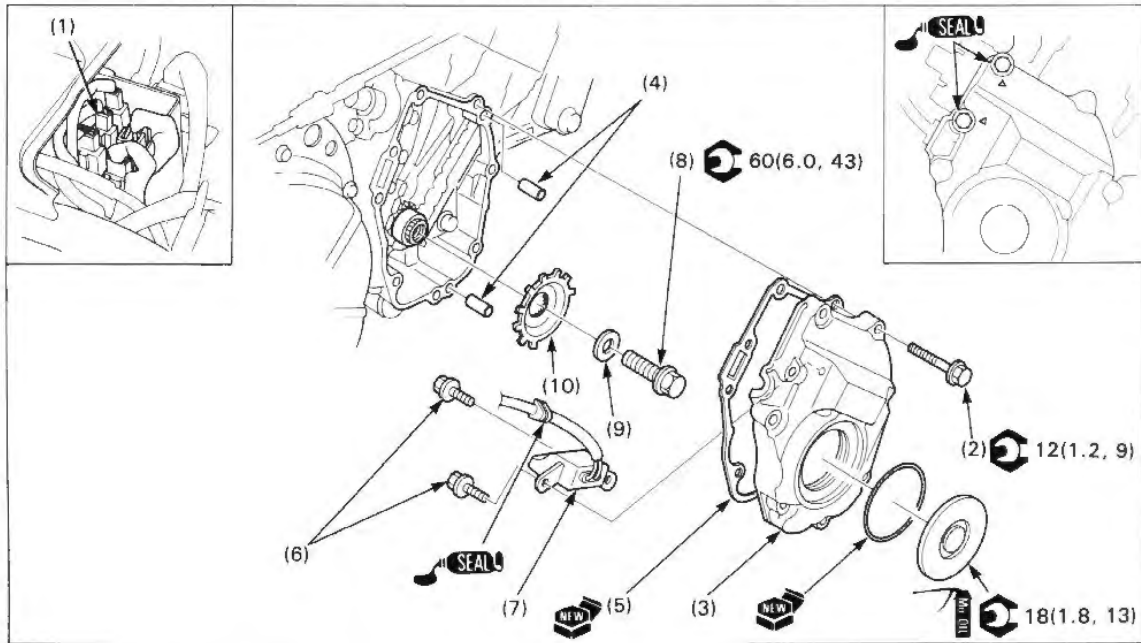

Requisite Service

- Fuel tank removal/installation (page 2-11)
- Left crankcase cover removal/installation (page 15-7)
(This is necessary if you plan to remove the pulse generator rotor.)

Procedure	Q'ty	Remarks
Removal Order		Installation is in the reverse order of removal.
(1) Ignition pulse generator connector	1	NOTE • Apply sealant to the threads of the bolts indicated by "Δ" marks.
(2) Ignition pulse generator rotor cover bolt	8	
(3) Ignition pulse generator rotor cover	1	When installing, apply sealant to the grommet and install the grommet securely into the groove in the ignition pulse generator rotor cover. NOTE • Remove the left crankcase cover (page 15-7) and loosen the bolt while holding the flywheel with a flywheel wrench (No. 07925-ME90000). • Be careful not to damage the rotor teeth during removal and installation.
(4) Dowel pin	2	
(5) Gasket	1	
(6) Bolt	2	
(7) Ignition pulse generator	1	
(8) Ignition pulse generator rotor bolt	1	
(9) Washer	1	
(10) Ignition pulse generator rotor	1	

17. Electric Starter

Service Information	17-1	Troubleshooting	17-3
System Location	17-2	Starter Motor Removal/Installation	17-5
Circuit Diagram	17-2	Starter Motor Disassembly/Assembly	17-6

Service Information

⚠ WARNING

- Always turn the ignition switch OFF before servicing the starter motor. The motor could suddenly start, causing serious injury.
- A weak battery may be unable to turn the starter motor quickly enough, or supply adequate ignition current.
- If the current is kept flowing through the starter motor to turn it while the engine is not cranking over, the starter motor may be damaged.
- For the following component inspections, refer to the following pages; for the parts locations, see page 17-2 of this manual (System Location).

Clutch switch diode	Section 24 of the Common Service Manual
Starter motor	Section 24 of the Common Service Manual
Starter relay switch	Section 24 of the Common Service Manual ("A" circuit type)
Clutch switch	Section 25 of the Common Service Manual
Neutral switch	Section 25 of the Common Service Manual
Ignition switch	Check for continuity on the continuity chart of the Wiring Diagram, section 19. Disconnect the switch connector at the back of the instruments and check it.
Side stand switch	See page 18-9.

System Location

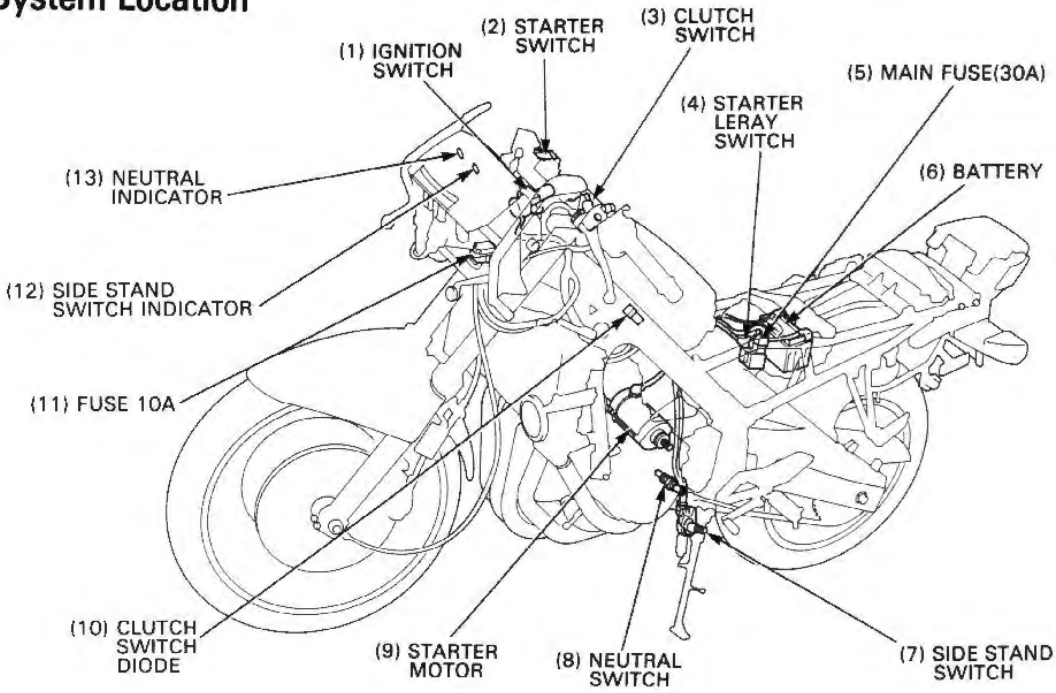

Circuit Diagram

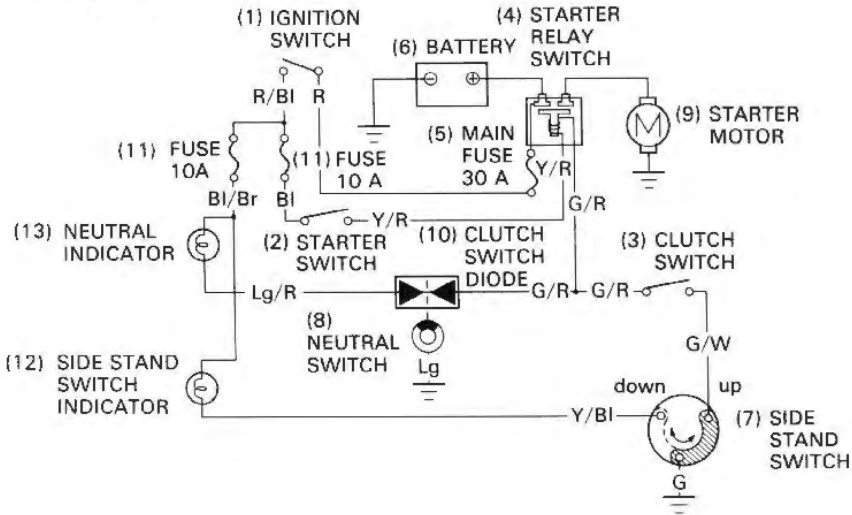

Troubleshooting

Starter motor will not turn

- Check for blown out main or sub fuses before servicing.
- Make sure the battery is fully charged and in good condition.

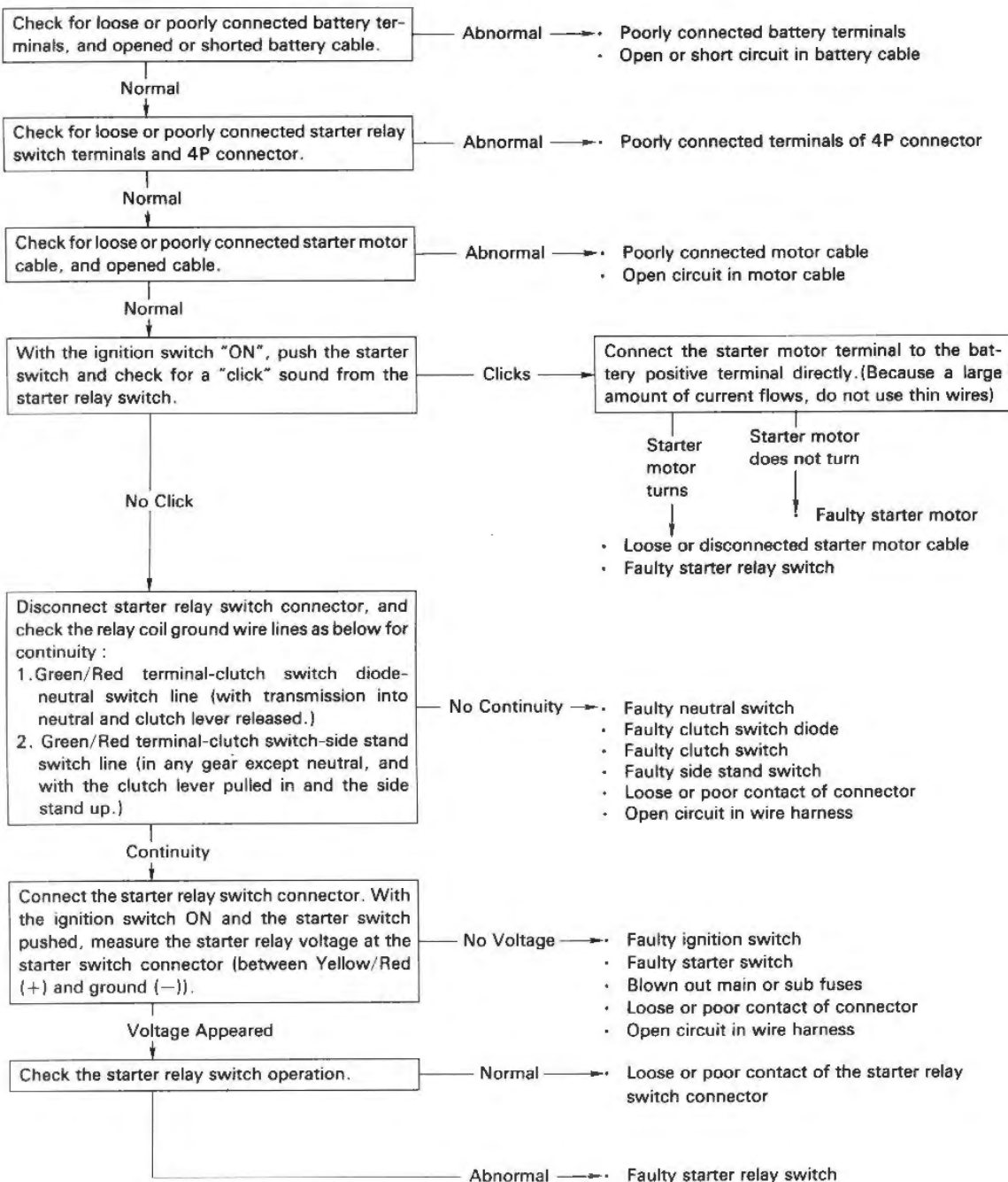

The starter motor turns when the transmission is in neutral, but does not turn with the transmission in any other position with the side stand up and the clutch lever pulled in.

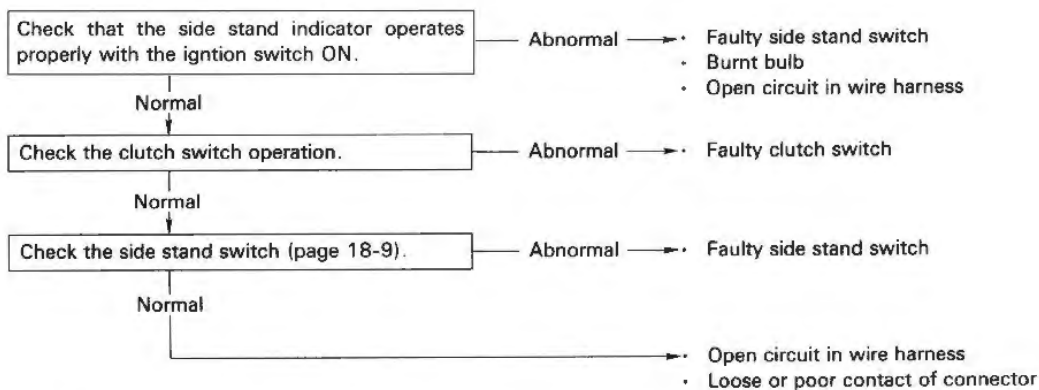

Starter motor turns slowly

- Low specific gravity in battery (or dead battery)
- Poorly connected battery terminal cable
- Poorly connected starter motor cable
- Faulty starter motor
- Poorly connected battery ground cable

Starter motor turns, but engine does not turn

- Starter motor is running backwards
 - Case assembled improperly
 - Terminals connected improperly
- Faulty starter clutch
- Damaged or faulty starter pinion
- Damaged reduction gears

Starter relay switch "clicks", but engine does not turn over

- Crankshaft does not turn due to engine problems
- Excessive reduction gear friction

Starter Motor Removal/Installation

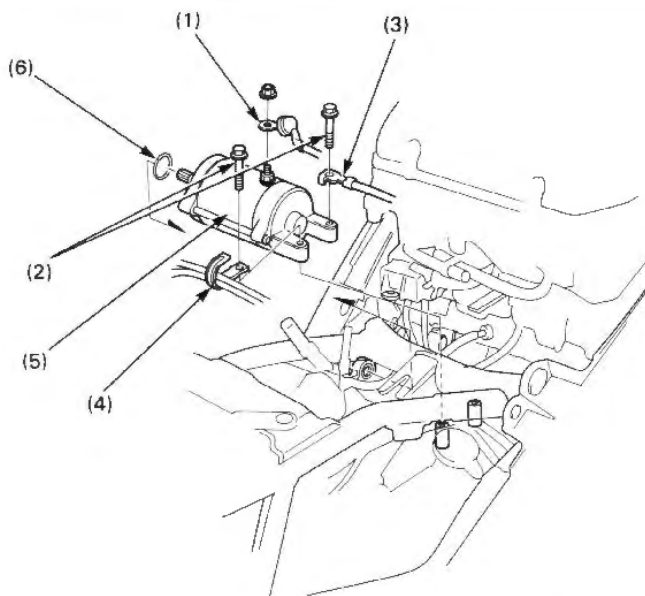

⚠ WARNING

- Turn the ignition switch OFF before removing the starter motor or cables.

Requisite Service

- Fuel tank removal/installation (page 2-11)

Procedure	Q'ty	Remarks
Removal Order		Installation is in the reverse order of removal.
(1) Starter motor cable	1	
(2) Starter motor mounting bolt	2	
(3) Ground cable	1	
(4) Clamp	1	
(5) Starter motor	1	
(6) O-ring	1	

Starter Motor Disassembly/Assembly

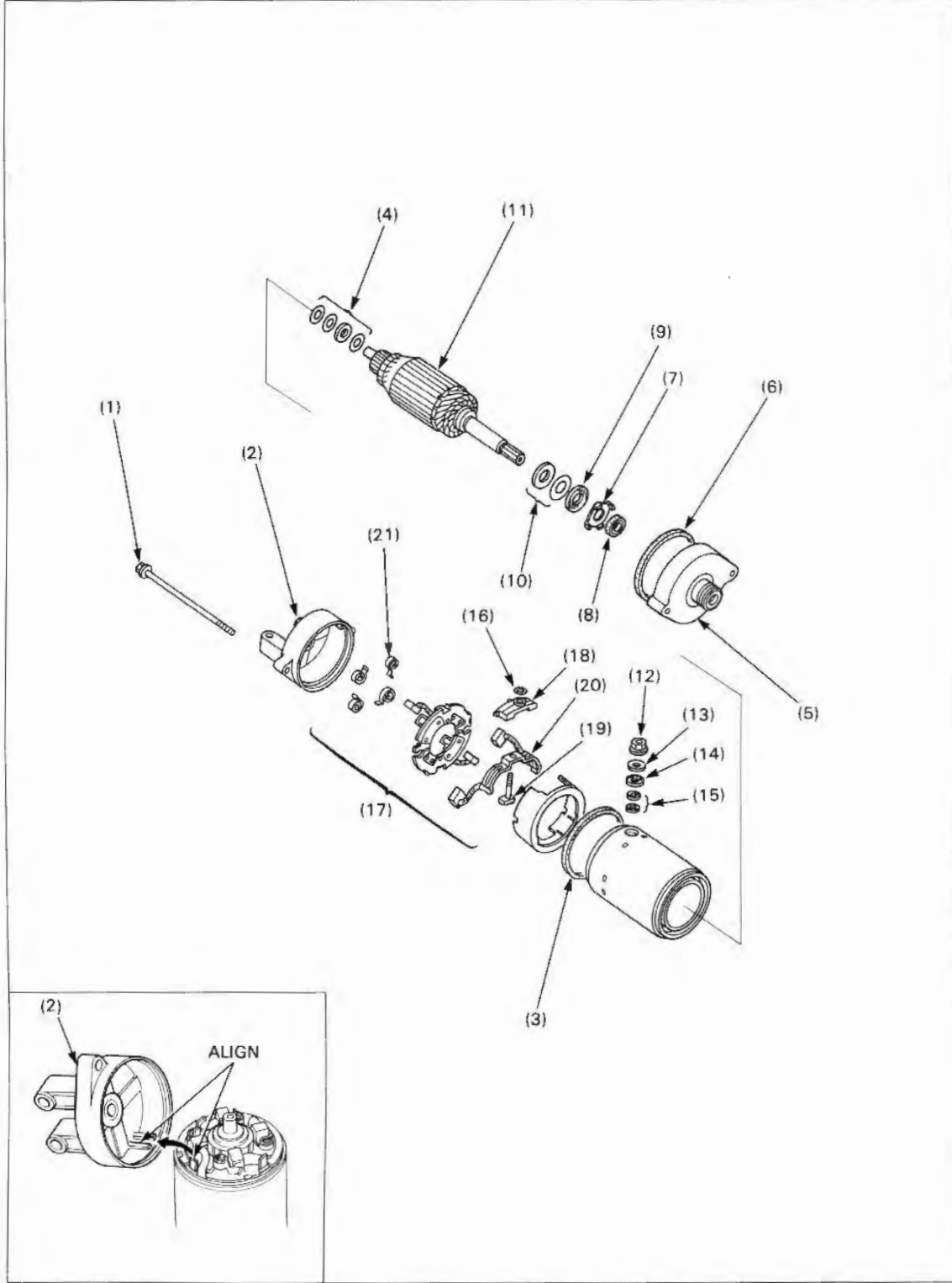

Requisite Service

- Starter motor removal/installation (page 17-5)

Procedure		Q'ty	Remarks
Disassembly Order			Assembly is in the reverse order of disassembly.
(1)	Bolt	2	
(2)	Rear cover	1	Install the rear cover with the tab of the blush holder plate between the tabs on the inside of the rear cover.
(3)	O-ring	1	
(4)	Shim	—	Record and store the shims in the same order they were removed so they can be reinstalled in the original positions.
(5)	Front cover	1	
(6)	O-ring	1	
(7)	Lock washer	1	
(8)	Dust seal	1	
(9)	Insulated washer	1	
(10)	Shim	—	
(11)	Armature	1	
(12)	Terminal nut	1	
(13)	Washer	1	
(14)	Insulated washer (large)	1	
(15)	Insulated washer (small)	2	
(16)	O-ring	1	
(17)	Blush holder assembly	1	Install the brush holder assembly with its tab aligning with the groove in the motor case.
(18)	-terminal bolt supporter	1	Install the supporter with its tab facing the brush holder side.
(19)	-terminal bolt	1	
(20)	-motor brush	1	
(21)	-brush spring	4	

18. Lights/Meters/Switches

Service Information	18-1	Combination Meter Disassembly/Assembly	18-6
System Location	18-2	Tachometer Inspection	18-8
Headlight Bulb Replacement	18-3	Coolant Temperature Gauge Inspection	18-8
Combination Meter Bulb Replacement	18-4	Ignition Switch Removal/Installation	18-8
Combination Meter Removal/Installation	18-5	Side Stand Switch	18-9

Service Information

▲ WARNING

- **A halogen headlight bulb becomes very hot while the headlight is ON, and remains hot for a while after it is turned OFF. Be sure to let it cool down before servicing.**
- **Use an electric heating element and heated water/coolant mixture for the thermo sensor inspection. Keep all flammable materials away from the electric heating element. Wear protective clothing, gloves and eye protection.**
- Note the following when replacing the halogen headlight bulb.
 - Wear clean gloves while replacing the bulb. Do not put finger prints on the headlight bulb, as they may create hot spots on the bulb and cause it to break.
 - If you touch the bulb with your bare hands, clean it with a cloth moistened with alcohol to prevent its early failure.
 - Be sure to install the dust cover after replacing the bulb.
- Check the battery condition before performing any inspection that requires proper battery voltage.
- A continuity test can be made with the switches installed on the vehicle.

System Location

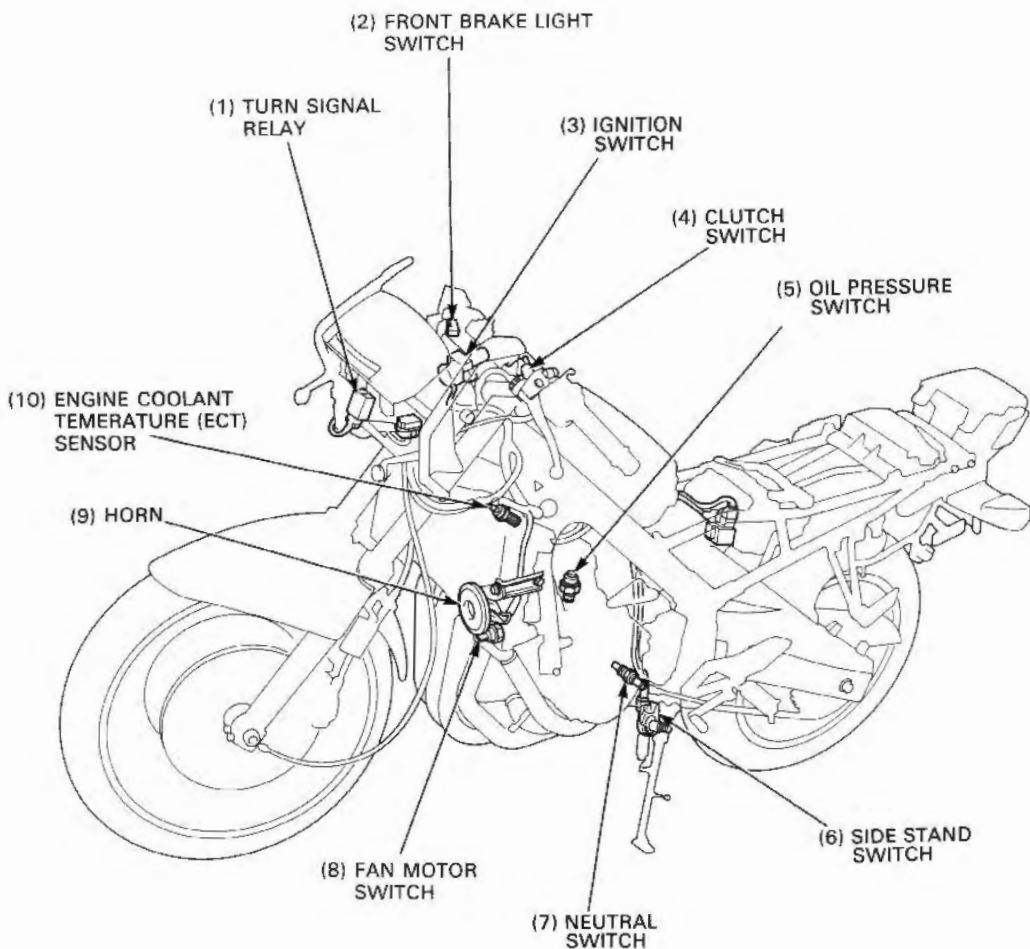

Headlight Bulb Replacement

WARNING

- Halogen headlight bulb becomes very hot while the headlight is ON, and remains hot for a while after it is turned OFF. Be sure to let it cool down before servicing.

CAUTION

- Wear clean gloves while replacing the bulb. Do not put finger prints on the headlight bulb, as they may create hot spots on the bulb and cause it to break.
- If you touch the bulb with your bare hands, clean it with a cloth moistened with alcohol to prevent its early failure.
- Be sure to install the dust cover after replacing the bulb.

Remove the tapping screws and release the claws of the cowl lower cover from the front cowl stay. Remove the front cowl lower cover.

Disconnect the headlight bulb socket and remove the rubber cover.

Release the bulb retainer and remove the headlight bulb.

Install a new bulb and the removed parts in the reverse order of removal.

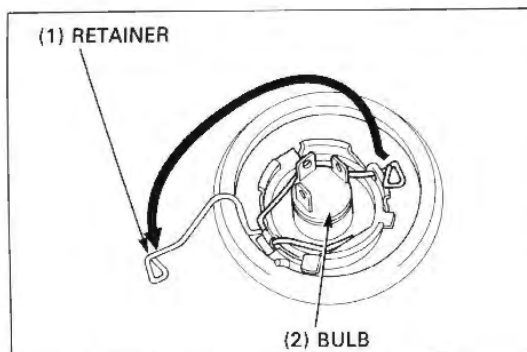
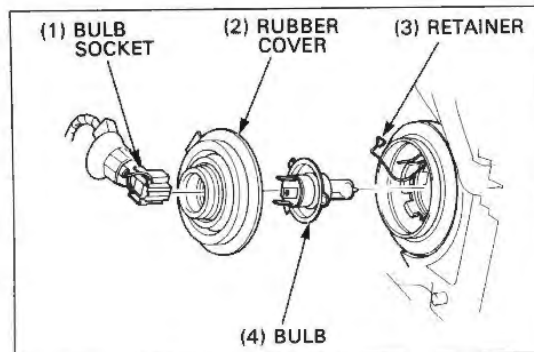
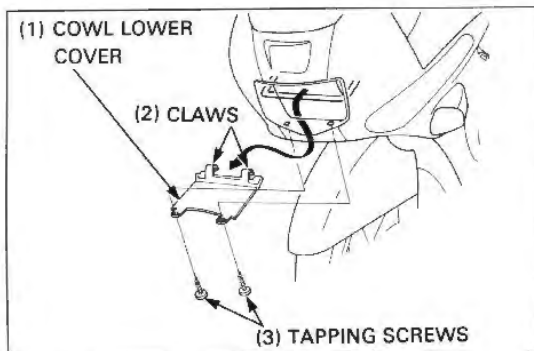

Combination Meter Bulb Replacement

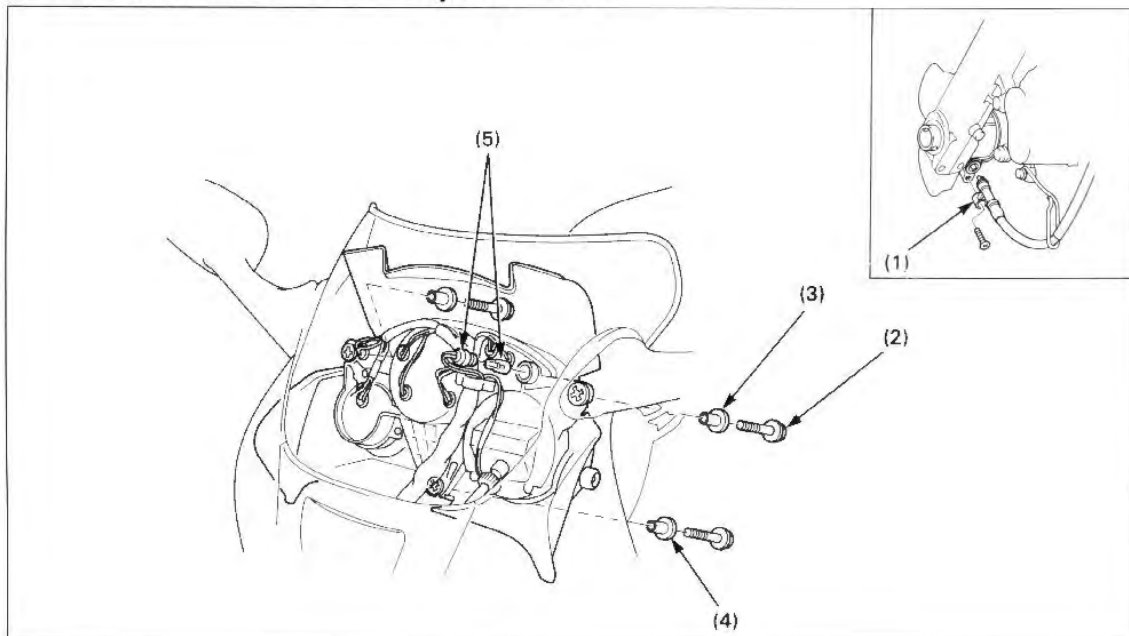

Procedure	Q'ty	Remarks
Removal Order		
(1) Speedometer cable	1	Installation is in the reverse order of removal. Disconnect the cable at the speedometer gear box.
(2) Meter mounting bolt	3	
(3) Collar (short)	2	Lift the combination meter and pull over the rubber cover so that you can remove the bulb socket.
(4) Collar (long)	1	
(5) Bulb socket/Bulb	11/11	

Combination Meter Removal/Installation

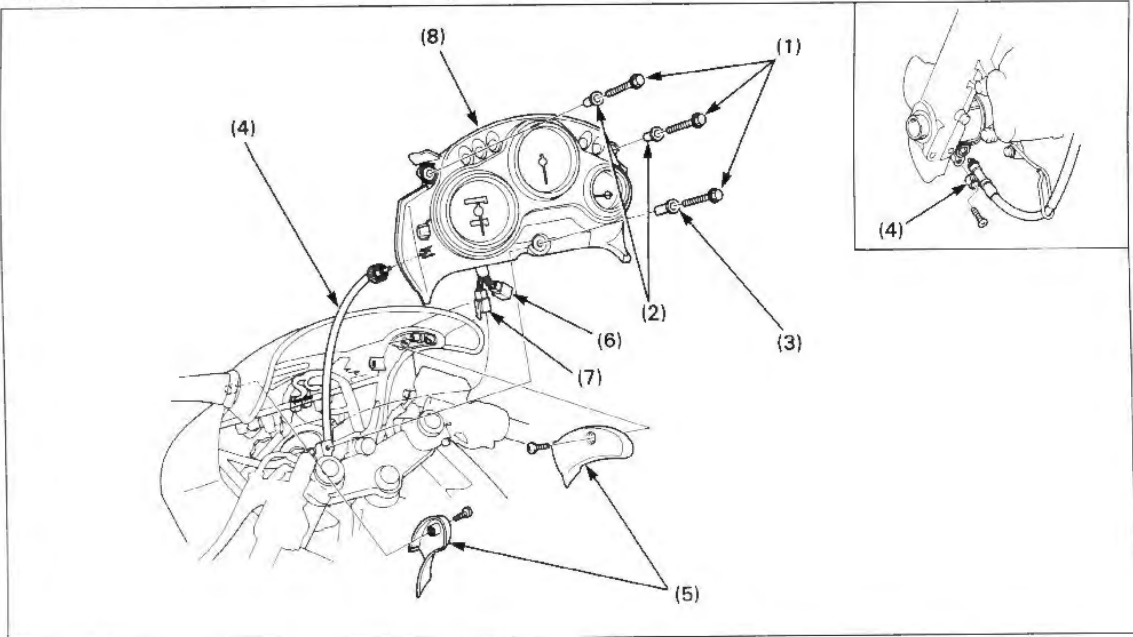

Requisite Service

- Wind screen removal/installation (page 2-4)

Procedure		Q'ty	Remarks
Removal Order			Installation is the reverse order of removal.
(1)	Meter mounting bolt	3	
(2)	Collar (short)	2	
(3)	Collar (long)	1	
(4)	Speedometer cable	1	Disconnect the speedometer cable at the speedometer gear box side, if necessary disconnect the cable from the meter after detaching the meter from the front cowl stay.
(5)	Rear view mirror inner cover	2	
(6)	9P mini connector	1	
(7)	6P mini connector	1	
(8)	Meter assembly	1	

Combination Meter Disassembly/Assembly

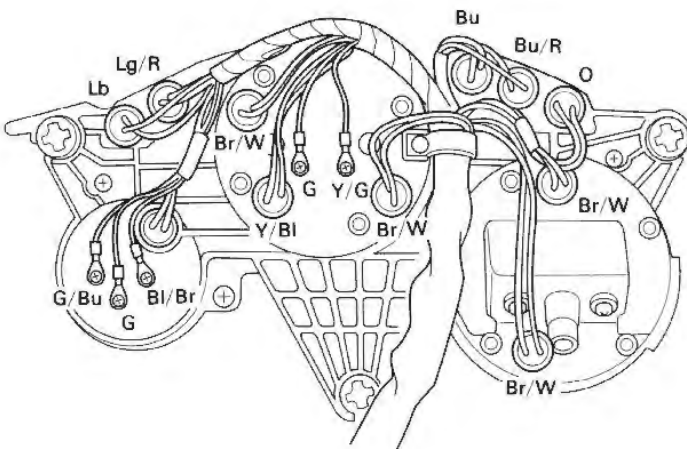
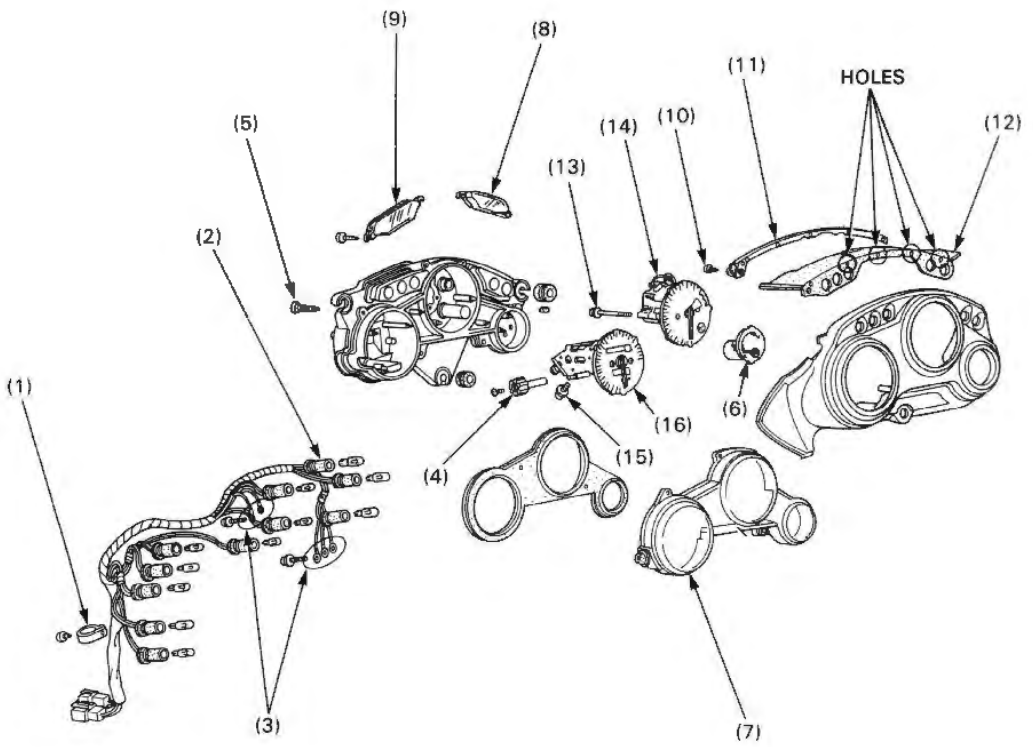

Requisite Service

- Combination meter removal/installation (page 18-5)

Procedure	Q'ty	Remarks
Disassembly Order		Assembly is in the reverse order of disassembly.
(1) Wire clamp	1	
(2) Bulb socket	11	Install each bulb socket referring to the wire color code stamped on the meter case.
(3) Wire terminal	5	
(4) Reset knob	1	
(5) Meter cover screw	6	
(6) Coolant temperature gauge	1	NOTE
		<ul style="list-style-type: none"> • Before assembling the meter case and meter cover, temporarily secure the coolant temperature gauge with the wire terminal screws. • When securing the coolant temperature gauge with the wire terminals, tighten the terminal screws with the meter facing up.
(7) Meter lens	1	
(8) Indicator lens (Neutral/Turn signal)	1	
(9) Indicator lens (High beam/Oil temperature/Turn signal)	1	
(10) Screw	3	
(11) Rubber cover retainer	1	
(12) Rubber cover	1	Align the four holes in the rubber cover with the pins on the meter cover.
(13) Screw	2	
(14) Tachometer	1	
(15) Screw	2	
(16) Speedometer	1	

Tachometer Inspection

Remove the right side cover (page 2-2) and disconnect the spark unit connector.

Check for continuity between the Yellow/Green wire terminals of the 9P mini connector and spark unit connector.

Continuity exists at all times.

If there is no continuity, replace the main wire harness.

If all checks are OK, replace the tachometer.

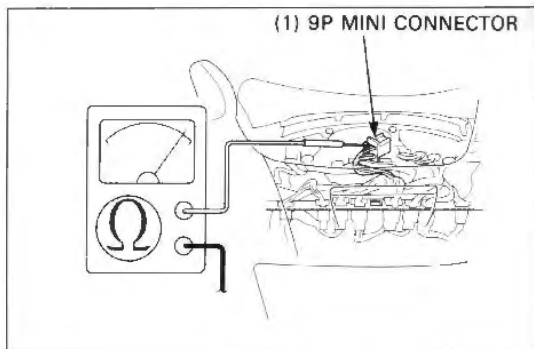

Coolant Temperature Gauge Inspection

Remove the fuel tank (page 2-11).

Disconnect the wire from the engine coolant temperature (ECT) sensor and short it to body ground.

Turn the ignition switch ON momentarily. The coolant temperature gauge needle should move all the way to "H".

CAUTION

- Do not leave the thermo sensor wire grounded for longer than a few seconds or the temperature gauge will be damaged.

Replace the temperature gauge with a new one if necessary.

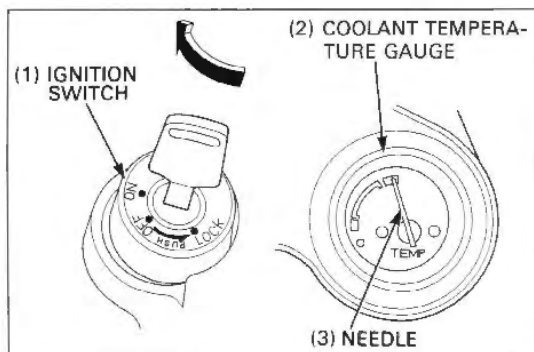
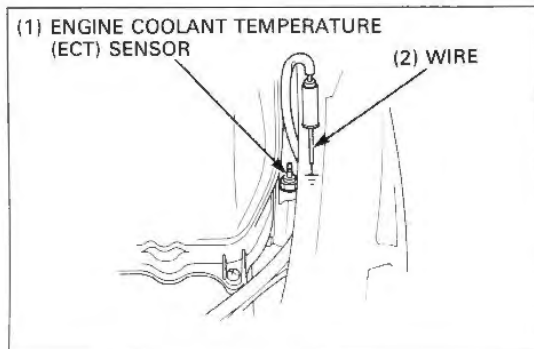

Ignition Switch Removal/Installation

Remove the wind screen (page 2-4).

Disconnect the 3P mini connector behind the combination meter.

Release the ignition switch wire from the clamps.

Remove the bolts and ignition switch.

5 TOOL

Torx bit (T40) 07703-0010100 or Equivalent commercially available

Apply a locking agent to the bolt threads and install the ignition switch in the reverse order of removal.

Torque : 25 N · m (2.5 kg-m, 18 ft-lb)

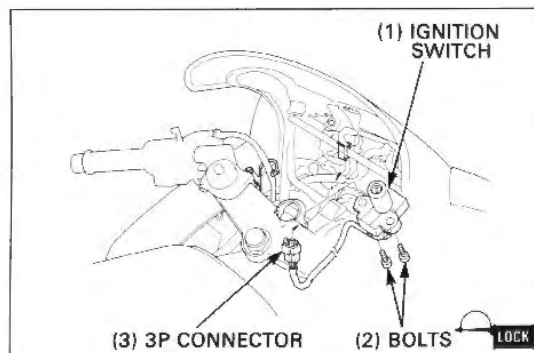

Side Stand Switch

Inspection

Remove the fuel tank (page 2-11).
Disconnect the side stand switch 3P mini connector.

(1) 3P MINI CONNECTOR (GREEN)

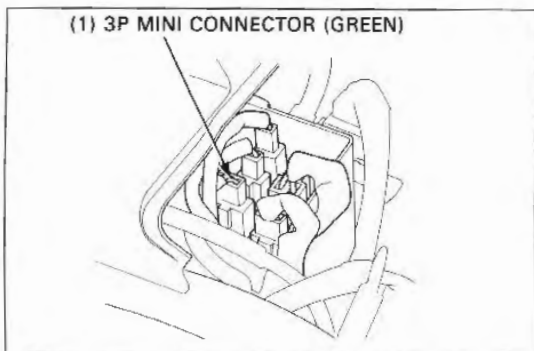

Check for continuity between each terminals as below.
There should be continuity between the \circ — \circ positions on the chart below.

	Green/White	Yellow/Black	Green
Side stand down		\circ — \circ	\circ — \circ
Side stand up	\circ — \circ	\circ — \circ	\circ — \circ

Removal/Installation

Remove the fuel tank (page 2-11).

Disconnect the side stand switch 3P mini connector (Green) and remove the bolt and side stand switch.

Install the side stand switch aligning the pin on the switch with the hole in the side stand.
Secure the side stand switch with the bolt.

Torque : 10 N · m (1.0kg·m, 7 ft·lb)

Install the removed parts in the reverse order of removal.

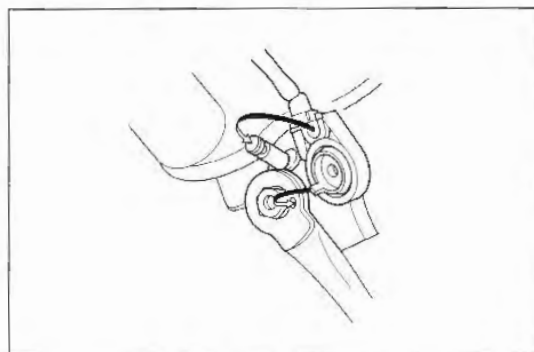
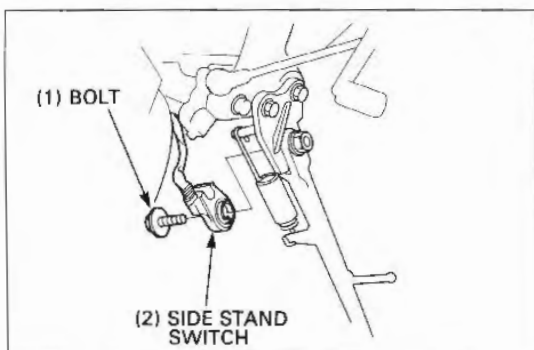
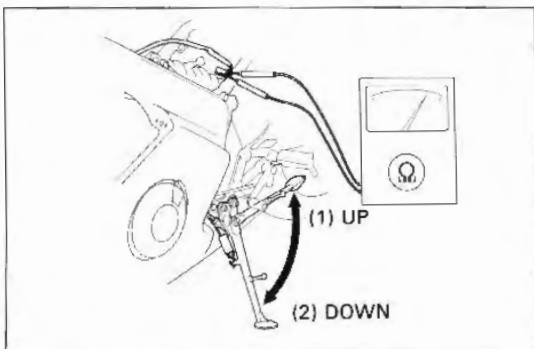

19. Wiring Diagram

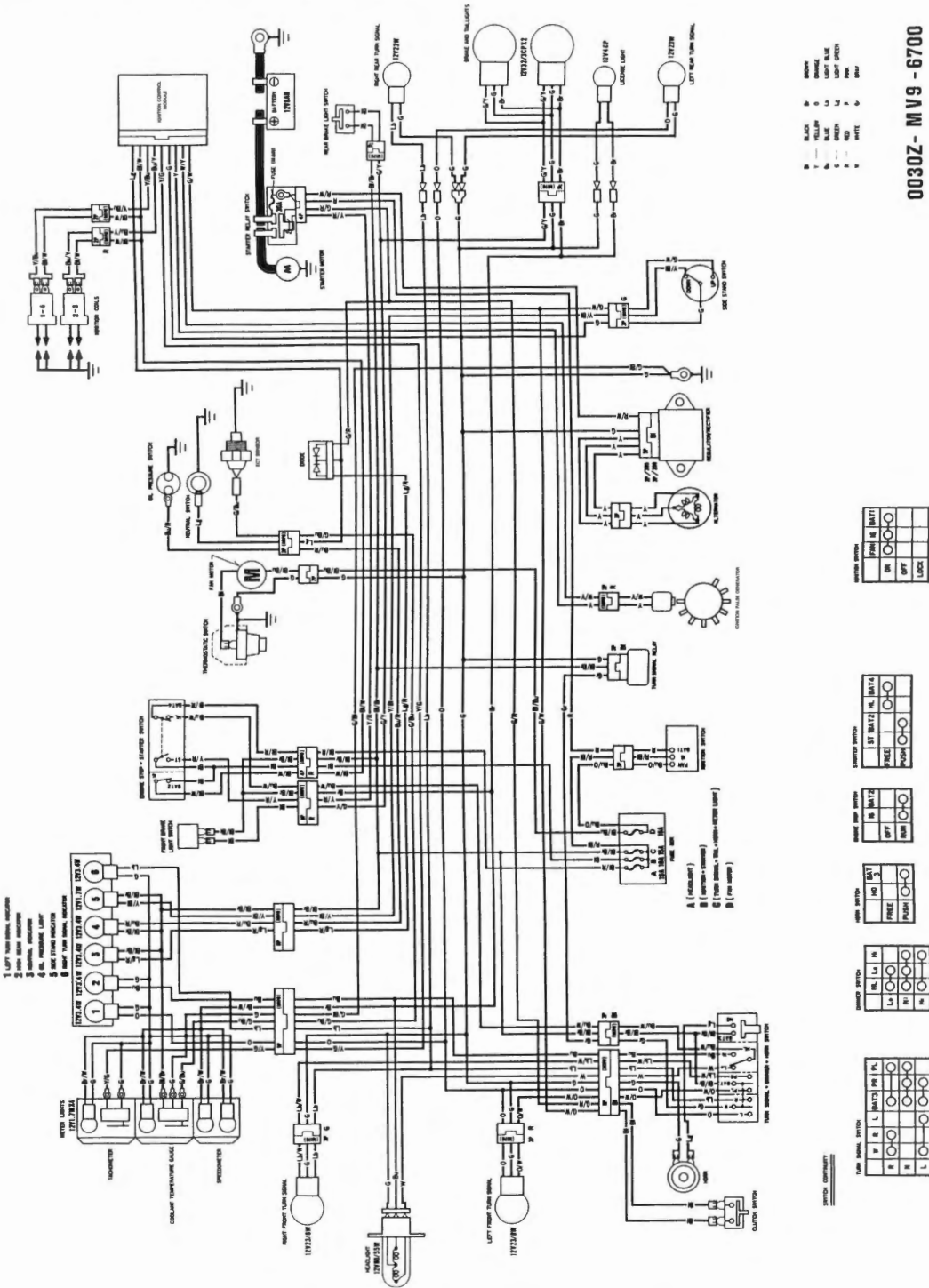

0030Z - MV9 - 6700

20. Troubleshooting

Engine Does Not Start or is Hard to Start	20-1	Poor Performance at High Speeds	20-4
Engine Lacks Power	20-2	Poor Handling	20-4
Poor Performance at Low And Idle Speeds	20-3		

Engine Does Not Start or is Hard to Start

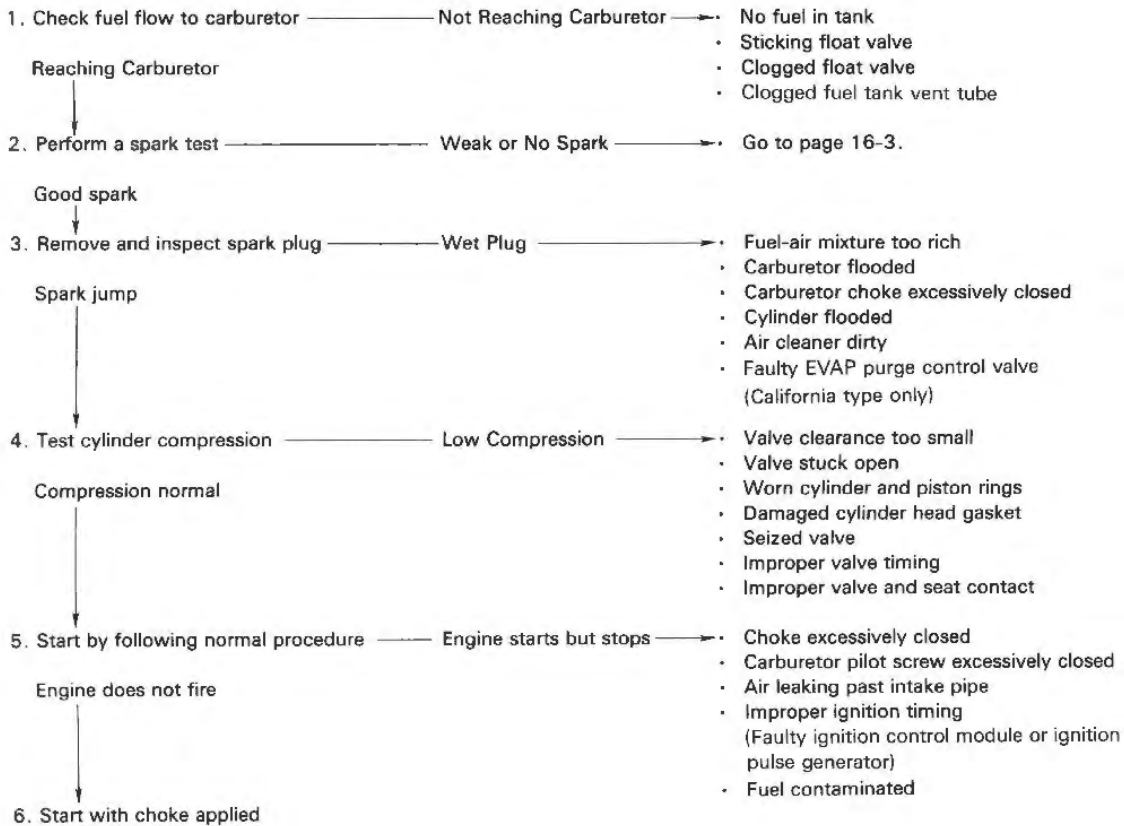

Engine Lacks Power

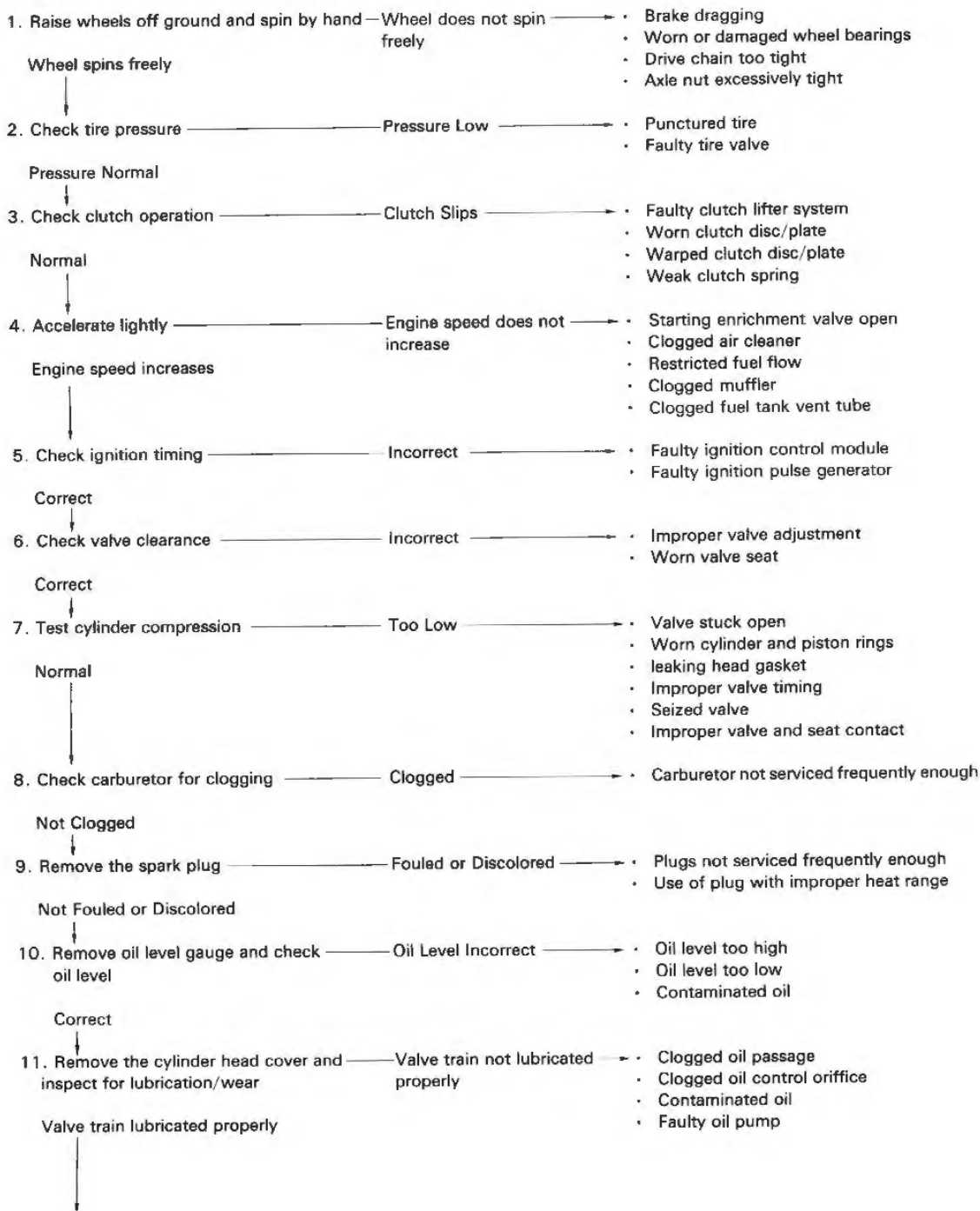

12. Check if engine overheats ————— Overheated —————>
- Coolant level low
 - Fan motor not working (faulty fan motor switch)
 - Thermostat stuck closed
 - Excessive carbon build-up on the piston head or combustion chamber
 - Use of improper quality fuel
 - Clutch slipping
 - Fuel-air mixture too lean
- Not Overheated
↓
13. Accelerate or run at high speed ————— Engine Knocks —————>
- Worn piston and cylinder
 - Fuel-air mixture too lean
 - Use of improper quality fuel
 - Excessive carbon build-up on the piston head or combustion chamber
 - Ignition timing too advanced (Faulty ignition control module or ignition pulse generator)

Poor Performance at Low and Idle Speeds

1. Check ignition timing and valve clearance ————— Incorrect —————>
- Improper valve clearance
 - Improper ignition timing (Faulty ignition control module or ignition pulse generator)
- Correct
↓
2. Check carburetor pilot screw adjustment ————— Incorrect —————>
- Fuel-air mixture too lean
 - Fuel-air mixture too rich
- Correct
↓
3. Check if air is leaking past intake pipe ————— Leaking —————>
- Deteriorated intake pipe O-ring
 - Loose carburetor
 - Damaged intake pipe
- Not Leaking
↓
4. Perform a spark test ————— Weak or Intermittent Spark —————>
- Faulty, carbon or wet fouled spark plug
 - Go to page 16-3

Poor Performance at High Speeds

1. Check ignition timing and valve clearance ————— Incorrect —————>
 - Improper valve clearance
 - Faulty ignition control module
 - Faulty ignition pulse generator

Correct
↓
2. Disconnect fuel tube at carburetor ————— Fuel flow restricted —————>
 - Lack of fuel in tank
 - Clogged fuel line
 - Clogged fuel tank vent tube
 - Clogged fuel valve
 - Clogged fuel strainer

Fuel flows freely
↓
3. Remove the carburetor and check for clogged jet(s) ————— Clogged —————>
 - Clogged jets

Not clogged
↓
4. Check valve timing ————— Incorrect —————>
 - Cam sprocket not installed properly

Correct
↓
5. Check valve spring ————— Damaged —————>
 - Faulty valve spring

Poor Handling

—————> Check tire pressure

1. If steering is heavy —————>
 - Bearing adjustment nut too tight
 - Damaged steering head bearing
 - Bent steering stem
2. If either wheel is wobbling —————>
 - Excessive wheel bearing play
 - Bent rim
 - Improperly installed wheel hub or wheel
 - Damaged swingarm pivot bearing
 - Bent axle
3. If the vehicle pulls to one side —————>
 - Front brake caliper dragging one side
 - Front and rear wheels not aligned
 - Bent fork pipe(s)
 - Bent swingarm
 - Distorted frame

Index

Air Cleaner Housing Removal/Installation.....	6-3	Ignition Timing.....	16-9
Air Cleaner.....	3-5	Left Handlebar Removal/ Installation.....	12-3
Alternator Removal/Installation.....	15-8	Lubrication & Seal Points.....	1-18
Battery Removal/Installation.....	15-4	Lubrication System Diagram.....	4-2
Cable & Harness Routing.....	1-20	Mainshaft Disassembly/ Assembly.....	11-8
Camshaft Removal/ Installation.....	8-2	Maintenance Schedule.....	3-4
Carburetor Combination.....	6-10	Model Identification.....	1-3
Carburetor Disassembly/ Assembly.....	6-8	Oil Cooler Disassembly/ Assembly.....	4-7
Carburetor Removal/ Installation.....	6-4	Oil Cooler Removal/ Installation.....	4-6
Carburetor Separation.....	6-6	Oil Pan Removal/ Installation.....	4-3
Carburetor Synchronization.....	3-9	Oil Pump Disassembly/ Assembly.....	4-5
Charging Coil Inspection.....	15-11	Oil Pump Removal/Installation.....	4-4
Charging System Inspection.....	15-6	Pilot Screw Adjustment.....	6-14
Circuit Diagram Charging System/ Alternator.....	15-2	Piston/Connecting Rod Removal/ Installation.....	10-4
Circuit Diagram Electric Starter.....	17-2	Pulse Secondary Air Injection (PAIR) Control Valve Removal/Installation (California Type Only).....	6-12
Circuit Diagram Ignition System.....	16-2	Radiator Disassembly/ Assembly.....	5-6
Clutch Installation.....	9-12	Radiator Removal/ Installation.....	5-5
Clutch Removal.....	9-4	Rear Brake Caliper Disassembly/ Assembly.....	14-12
Combination Meter Bulb Replacement.....	18-4	Rear Brake Caliper Removal/ Installation.....	14-11
Combination Meter Disassembly/ Assembly.....	18-6	Rear Brake Pad Replacement.....	14-2
Combination Meter Removal/ Installation.....	18-5	Rear Fender A Removal/ Installation.....	2-8
Coolant Draining.....	5-3	Rear Fender B Removal/ Installation.....	2-7
Coolant Temperature Gauge Inspection.....	18-8	Rear Master Cylinder Disassembly/ Assembly.....	14-10
Countershaft Disassembly.....	11-10	Rear Master Cylinder Removal/ Installation.....	14-8
Crankcase Assembly.....	10-6	Rear Wheel Disassembly/Assembly.....	13-3
Crankcase Separation.....	10-2	Rear Wheel/Removal/Installation.....	13-2
Crankshaft Bearing Replacement.....	11-4	Regulator/ Rectifier.....	15-7
Crankshaft Removal/ Installation.....	11-2	Reserve Tank Removal/ Installation.....	5-8
Cylinder Head Disassembly/ Assembly.....	8-8	Right Crankcase Cover Removal/ Installation.....	9-2
Cylinder Head Removal/ Installation.....	8-7	Right Handlebar Removal/ Installation.....	12-2
Emission Control Systems (U.S.A. Only).....	1-25	Seat Removal/ Installation.....	2-2
Emission Control Information Labels (U.S.A. Only).....	1-28	Service Access Guide.....	3-2
Engine Removal/ Installation.....	7-2	Service Information Brake System.....	14-1
Evaporative Emission (EVAP) Canister Removal/ Installation (California Type Only).....	6-13	Charging System/ Alternator.....	15-1
Exhaust System Removal/Installation.....	2-10	Clutch/ Gearshift Linkage.....	9-1
Flywheel Removal/Installation.....	15-9	Cooling System.....	5-1
Fork Assembly ('91-'93).....	12-14	Crankcase/ Cylinder/ Piston.....	10-1
Fork Assembly (After '93).....	12-16	Crankshaft/ Transmission.....	11-1
Fork Disassembly ('91-'93).....	12-10	Cylinder Head.....	8-1
Fork Disassembly (After '93).....	12-12	Electric Starter.....	17-1
Fork Removal/ Installation.....	12-8	Engine Removal/ Installation.....	7-1
Front Brake Caliper Disassembly/ Assembly.....	14-6	Frame/ Body Panels/ Exhaust System.....	2-1
Front Brake Caliper Removal/ Installation.....	14-5	Front Wheel/ Suspension/ Steering.....	12-1
Front Cowl Disassembly/ Assembly.....	2-6	Fuel System.....	6-1
Front Cowl Removal/ Installation.....	2-4	Ignition System.....	16-1
Front Master Cylinder Disassembly/ Assembly.....	14-4	Lights/ Meters/ Switches.....	18-1
Front Master Cylinder Removal/ Installation.....	14-3	Lubrication System.....	4-1
Front Wheel Disassembly/Assembly.....	12-6	Maintenance.....	3-1
Front Wheel Removal/Installation.....	12-4	Rear Wheel/ Suspension.....	3-1
Fuel Tank Removal/ Installation.....	2-11	Shift Drum/ Shift Forks Removal/ Installation.....	9-10
Gearshift Linkage Removal/ Installation.....	9-8	Shock Absorber Disassembly/Assembly ('91-'93).....	13-6
General Safety.....	1-1	Shock Absorber Removal/ Installation ('91-'93).....	13-4
Headlight Bulb Replacement.....	18-3	Shock Absorber Removal/ Installation (After '93).....	13-5
High Altitude Adjustment (U.S.A. Only).....	6-15	Side Cover Removal/ Installation.....	2-2
Ignition Coil Inspection.....	16-6	Side Fairing Removal/ Installation.....	2-3
Ignition Pulse Generator Rotor Cover Removal/ Installation.....	16-10	Side Stand.....	3-10
Ignition Pulse Generator.....	16-9	Side Stand Switch.....	18-9
Ignition Coil Removal/ Installation.....	16-8	Spark Plug.....	3-5
Ignition Switch Removal/ Installation.....	18-8	Specifications.....	1-4
Ignition System Inspection.....	16-6	Starter Motor Disassembly/ Assembly.....	17-6

Starter Motor Removal/ Installation.....	17-5
Steering Stem Removal/ Installation.....	12-18
Suspension Linkage Disassembly/ Assembly...	13-9
Suspension Linkage Removal/ Installation.....	13-8
Swingarm Disassembly/ Assembly.....	13-14
Swingarm Removal/ Installation.....	13-12
System Flow Pattern.....	5-2
System Location Charging System/ Alternator	15-2
System Location Electric Starter.....	17-2
System Location Ignition System.....	16-2
System Location Lights/Meters/Switches.....	18-2
Tachometer Inspection.....	18-8
Tail Cowl Removal/Installation.....	2-7
Thermostart Removal/ Installation.....	5-4
Tools.....	1-17
Torque Values.....	1-14
Transmission Removal/ Installation.....	11-6
Troubleshooting Brake System.....	14-1
Charging System/ Alternator.....	15-3
Clutch/Gearshift Linkage.....	9-1
Cooling System.....	5-1
Crankcase/Cylinder/Piston.....	10-1
Crankshaft/ Transmission.....	11-1
Cylinder Head.....	8-1
Electric Starter.....	17-3
Engine Does Not Start or is Hard to	
Start.....	20-1
Engine Lacks Power.....	20-2
Frame/ Body Panels/ Exhaust System..	2-1
Front Wheel/ Suspension/ Steering.....	12-1
Fuel System.....	6-2
Ignition System.....	16-3
Lubrication System.....	4-1
Poor Handling.....	20-4
Poor Performance at High Speeds.....	20-4
Poor Performance at Low And Idle	
Speeds.....	20-3
Rear Wheel/ Suspension.....	13-1
Valve Clearance.....	3-5
Water Pump Disassembly/Assembly.....	5-7
Wiring Diagram.....	19-1