

HONDA

SERVICE MANUAL

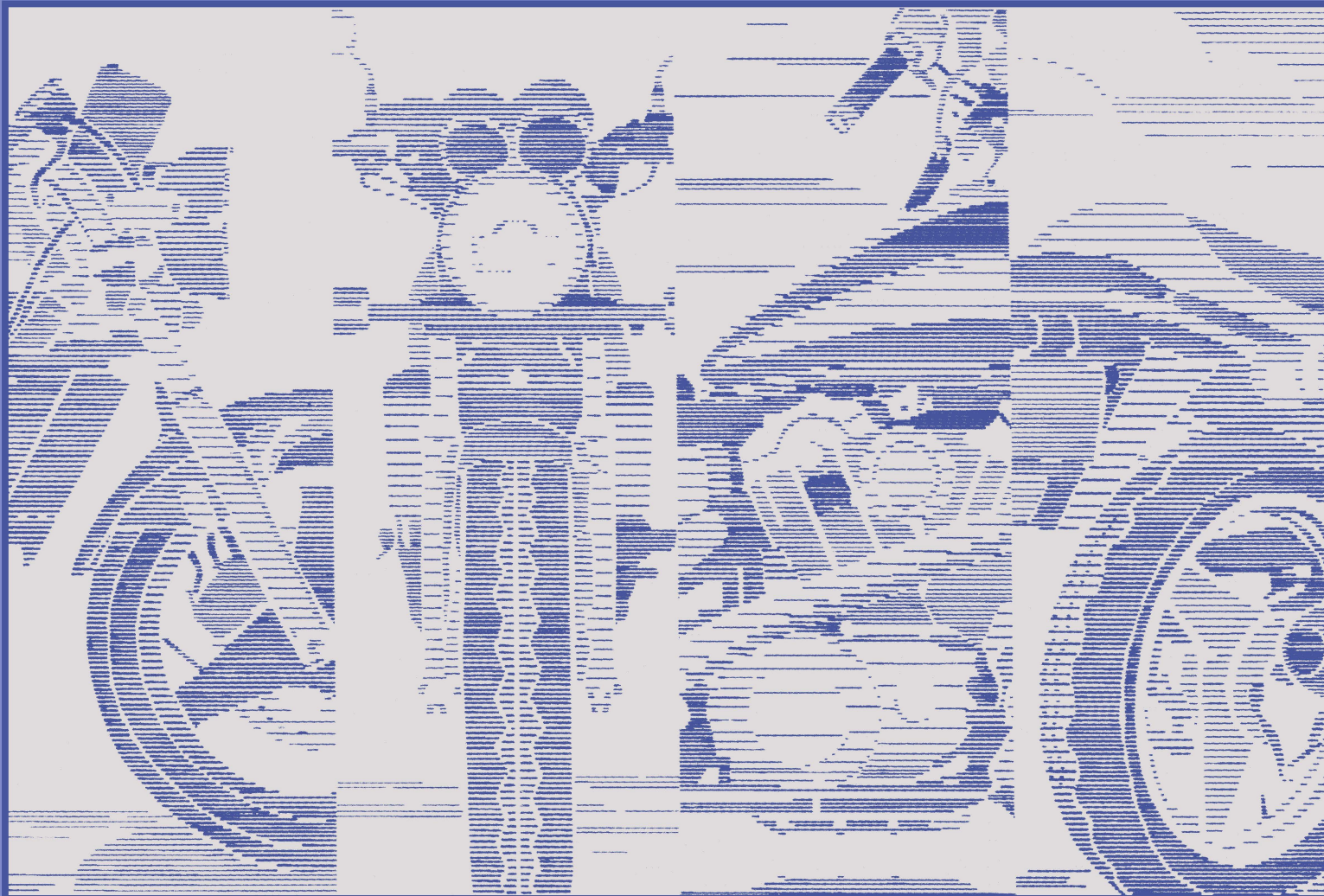

1994-2003

MAGNA[®] VF750C/CD

Important Safety Notice

 **WARNING** Indicates a strong possibility of severe personal injury or death if instructions are not followed.

CAUTION: Indicates a possibility of personal injury or equipment damage if instructions are not followed.

NOTE: Gives helpful information.

Detailed descriptions of standard workshop procedures, safety principles and service operations are not included. It is important to note that this manual contains some warnings and cautions against some specific service methods which could cause **PERSONAL INJURY** to service personnel or could damage a vehicle or render it unsafe. Please understand that those warnings could not cover all conceivable ways in which service, whether or not recommended by Honda, might be done or of the possibly hazardous consequences of each conceivable way, nor could Honda investigate all such ways. Anyone using service procedures or tools, whether or not recommended by Honda, must satisfy himself thoroughly that neither personal safety nor vehicle safety will be jeopardized by the service methods or tools selected.

Introduction

This service manual describes the service procedures for the MAGNA VF750C/CD.

This Model Specific Manual includes every service procedure that is of a specific nature to this particular model. Basic service procedures that are common to other Honda Motorcycle/Motor Scooter/ATVs are covered in the Common Service Manual. This Model Specific Service Manual should be used together with the Common Service Manual in order to provide complete service information on all aspects of this motorcycle.

Follow the Maintenance Schedule (Section 3) recommendations to ensure that the vehicle is in peak operating condition and the emission levels are within the standards set by the U.S. Environmental Protection Agency and the California Air Resources Board. Performing the first scheduled maintenance is very important. It compensates for the initial wear that occurs during the break-in period.

Sections 1 and 3 apply to the whole motorcycle. Section 2 illustrates procedures for removal/installation of components that may be required to perform service described in the following sections.

Sections 4 through 19 describe parts of the motorcycle, grouped according to location.

Find the section you want on this page, then turn to the table of contents on the first page of the section.

Most sections describe the service procedure through system illustration. Refer to the next page for details on how to use this manual.

If you are not familiar with this motorcycle, read Technical Feature in section 20.

If you don't know the source of the trouble, go to section 21 Troubleshooting.

All information, illustrations, directions and specifications included in this publication are based on the latest product information available at the time of approval for printing. Honda Motor Co., LTD. reserves the right to make changes at any time without notice and without incurring any obligation whatever. No part of this publication may be reproduced without written for permission. This manual is written for persons who have acquired basic knowledge of maintenance on Honda motorcycles, motor scooters or ATVs.

HONDA MOTOR CO., LTD.
Service Publications Office

Contents

	General Information	1
	Frame/Body Panels/Exhaust System	2
	Maintenance	3
Engine and Drive Train	Lubrication System	4
	Fuel System	5
	Cooling System	6
	Engine Removal/Installation	7
	Cylinder Head/Valves	8
	Clutch System	9
	Gearshift Linkage	10
	Crankshaft/Piston/Transmission	11
Chassis	Front Wheel/Suspension/Steering	12
	Rear Wheel/Suspension	13
	Brake System	14
Electrical	Charging System/Alternator	15
	Ignition System	16
	Electric Starter/Starter Clutch	17
	Lights/Meters/Switches	18
	Wiring Diagram	19
	Technical Feature	20
	Troubleshooting	21
	Index	22

How To Use This Manual

Finding The Information You Need

- This manual is divided into sections which cover each of the major components of the motorcycle.
- To quickly find the section you are interested in, the first page of each section is marked with a black tab that lines up with one of the thumb index tabs before this page.
- The first page of each section lists the table of contents within the section.
- Read the service information and troubleshooting related to the section before you begin working.
- An index of the entire book is provided in the last chapter to directly locate the information you need.

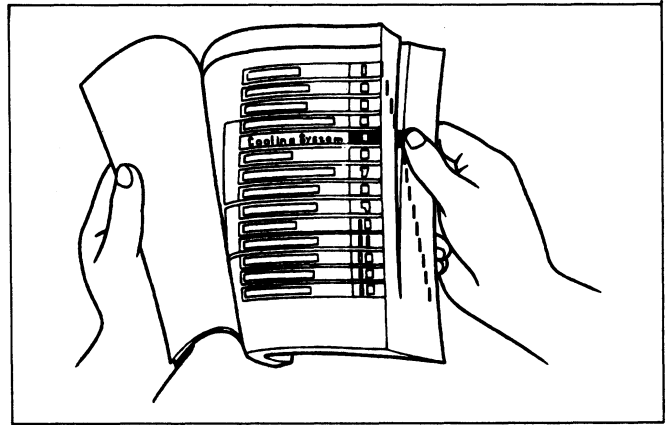

Note On the Explanation Method Of This Manual

- The removal and installation of parts are for the most part illustrated by large and clear illustrations that should provide the reader with visual aid in understanding the major point for servicing.
- The system illustrations are augmented by call outs whose numbers or letters indicate the order in which the parts should be removed or installed.
- The sequence of steps represented numerically are differentiated from the ones represented alphabetically to notify the reader that they must perform these steps separately.
- The illustrations may contain symbols to indicate necessary service procedures and precautions that need to be taken. Refer to the next page for the meaning of each symbol.
- Also in the illustration is a chart that lists information such as the order in which the parts is removal/installed, the name of the part, and some extra notes that may needed.
- Step by step instructions are provided to supplement the illustrations when detailed explanation of the procedure is necessary or illustrations alone would not suffice.
- Service procedures required before or after the procedure described on that particular page, or inspection/adjustment procedures required following the installation of parts, are described under the title Requisite Service.
- Standard workshop procedures and knowledge covered in the Common Service Manual are abbreviated in this manual.

System illustration

Symbols

Detailed description of the procedure

Step sequence (numerals or alphabets)

Part name

Number of parts















Extra notes or precaution related to the service procedure

12-14

12-15

Symbols

The symbols used throughout this manual show specific service procedures. If supplementary information is required pertaining to these symbols, it would be explained specifically in the text without the use of the symbols.

	Replace the part(s) with new one(s) before assembly.
	Use special tool.
	Use optional tool. These tools are obtained as you order parts.
 10 (1.0,7)	Torque specification. 10 N-m (1.0 kg-m, 7 ft-lb)
	Use recommended engine oil, unless otherwise specified.
	Use molybdenum oil solution (mixture of the engine oil and molybdenum grease with the ratio 1:1).
	Use multi-purpose grease (Lithium based multi-purpose grease NLGI #2 or equivalent).
	Use molybdenum disulfide grease (containing more than 3% molybdenum disulfide, NLGI #2 or equivalent). Example: Molykote® BR-2 plus manufactured by Dow Corning, U.S.A. Multi-purpose M-2 manufactured by Mitsubishi Oil Japan
	Use molybdenum disulfide paste (containing more than 40% molybdenum disulfide, NLGI #2 or equivalent). Example: Molykote® G-n Paste manufactured by Dow Corning, U.S.A. Honda Moly 60 (U.S.A. only) Rocol ASP manufactured by Rocol Limited, U.K. Rocol Paste manufactured by Sumico Lubricant, Japan
	Use silicone grease.
	Apply a locking agent. Use the agent of the middle strength, unless otherwise specified.
	Apply sealant.
	Use brake fluid DOT 4. Use the recommended brake fluid, unless otherwise specified.
	Use Fork or Suspension Fluid.

MEMO

1. General Information

General Safety	1-1	Lubrication & Seal Points	1-17
Model Identification	1-3	Cable & Harness Routing	1-20
Specifications	1-4	Emission Control System (U.S.A. Only)	1-27
Torque Values	1-12	Emission Control Information Labels (U.S.A Only)	1-30
Tools	1-15		

General Safety

Carbon Monoxide

If the engine must be running to do some work, make sure the area is well ventilated. Never run the engine in an enclosed area.

⚠ WARNING

- **The exhaust contains poisonous carbon monoxide gas that may cause loss of consciousness and may lead to death.**

Run the engine in an open area or with an exhaust evacuation system in an enclosed area.

Gasoline

Work in a well ventilated area. Keep cigarettes, flames or sparks away from the work area or where gasoline is stored.

⚠ WARNING

- **Gasoline is extremely flammable and is explosive under certain conditions. KEEP OUT OF REACH OF CHILDREN.**

Hot Components

⚠ WARNING

- **Engine and exhaust system parts become very hot and remain hot for some time after the engine is run. Wear insulated gloves or wait until the engine and exhaust system have cooled before handling these parts.**

Used Engine/Transmission Oil

⚠ WARNING

- **Used engine oil (or transmission oil in two-stroke) may cause skin cancer if repeatedly left in contact with the skin for prolonged periods. Although this is unlikely unless you handle used oil on a daily basis, it is still advisable to thoroughly wash your hands with soap and water as soon as possible after handling used oil. KEEP OUT OF REACH OF CHILDREN.**

Brake Dust

Never use an air hose or dry brush to clean brake assemblies. Use an OSHA-approved vacuum cleaner or alternate method approved by OSHA, designed to minimize the hazard caused by airborne asbestos fibers.

⚠ WARNING

- **Inhaled asbestos fibers have been found to cause respiratory disease and cancer.**

Brake Fluid

CAUTION

- **Spilling fluid on painted, plastic or rubber parts will damage them. Place a clean shop towel over these parts whenever the system is serviced. KEEP OUT OF REACH OF CHILDREN.**

Coolant

Under some conditions, the ethylene glycol in engine coolant is combustible and its flame is not visible. If the ethylene glycol does ignite, you will not see any flame, but you can be burned.

⚠ WARNING

- **Avoid spilling engine coolant on the exhaust system or engine parts. They may be hot enough to cause the coolant to ignite and burn without a visible flame.**
- **Coolant (ethylene glycol) can cause some skin irritation and is poisonous if swallowed. KEEP OUT OF REACH OF CHILDREN.**
- **Do not remove the radiator cap when the engine is hot. The coolant is under pressure and could scald you.**
- **Keep hands and clothing away from the cooling fan, as it starts automatically.**

If it contacts your skin, wash the affected areas immediately with soap and water. If it contacts your eyes, flush them thoroughly with fresh water and get immediate medical attention. If it is swallowed, the victim must be forced to vomit, then rinse mouth and throat with fresh water before obtaining medical attention. Because of these dangers, always store coolant in a safe place, away from the reach of children.

Nitrogen Pressure

For shock absorbers with a gas-filled reservoir:

⚠ WARNING

- **Use only nitrogen to pressurize the shock absorber. The use of an unstable gas can cause a fire or explosion resulting in serious injury.**
- **The shock absorber contains nitrogen under high pressure. Allowing fire or heat near the shock absorber could lead to an explosion that could result in serious injury.**
- **Failure to release the pressure from a shock absorber before disposing of it may lead to a possible explosion and serious injury if it is heated or pierced.**

To prevent the possibility of an explosion, release the nitrogen by pressing the valve core. Then remove the valve stem from the shock absorber reservoir. Dispose of the oil in a manner acceptable to the Environmental Protection Agency (EPA).

Before disposal of the shock absorber, release the nitrogen by pressing the valve core. Then remove the valve stem from the shock absorber.

Battery Hydrogen Gas & Electrolyte

⚠ WARNING

- **The battery gives off explosive gases; keep sparks, flames and cigarettes away. Provide adequate ventilation when charging.**
- **The battery contains sulfuric acid (electrolyte). Contact with skin or eyes may cause severe burns. Wear protective clothing and a face shield.**
 - **If electrolyte gets on your skin, flush with water.**
 - **If electrolyte gets in your eyes, flush with water for at least 15 minutes and call a physician immediately.**
- **Electrolyte is poisonous.**
 - **If swallowed, drink large quantities of water or milk and follow with milk of magnesia or vegetable oil and call a physician. KEEP OUT OF REACH OF CHILDREN.**

Model Identification

'94 MAGNA VF750C shown

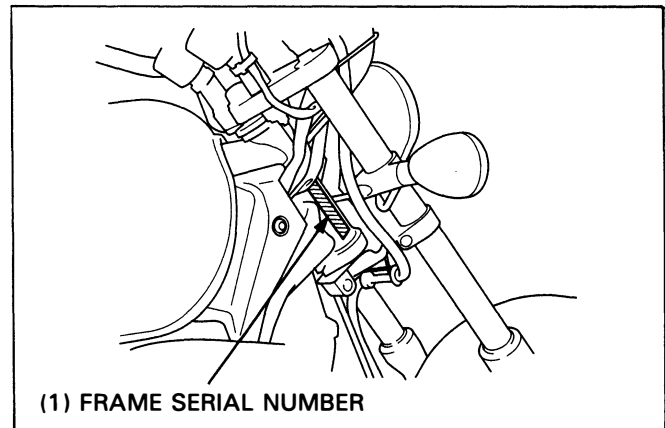
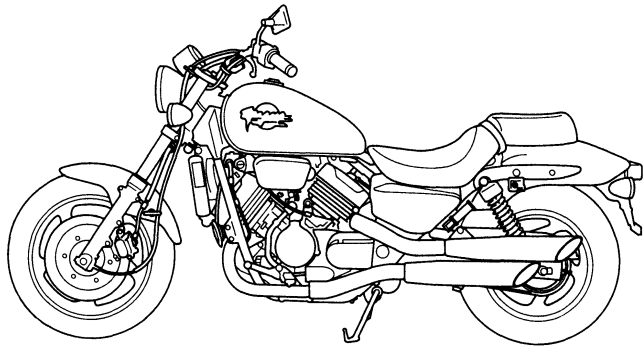

(1) The frame serial number is stamped on the right side of the steering head.

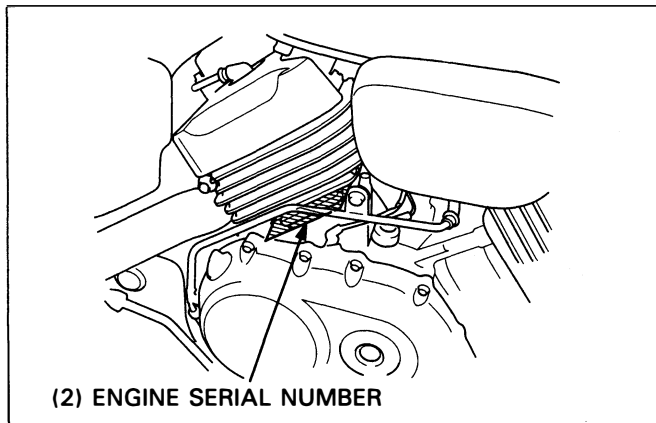

(2) The engine serial number is stamped on the right side of the upper crankcase.

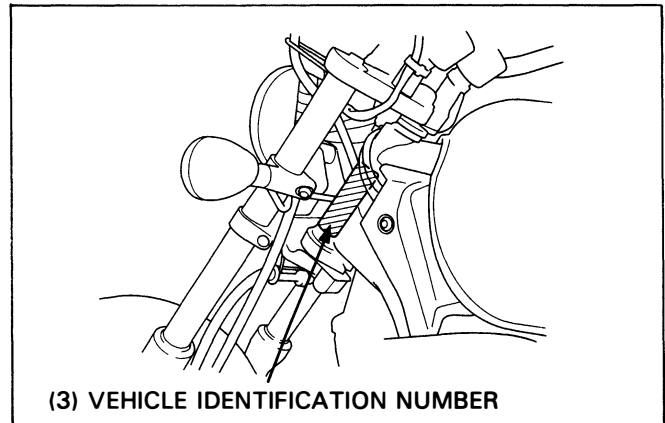

(3) The vehicle Identification Number (VIN) is located on the Safety Certification Label on the left side of the steering head.

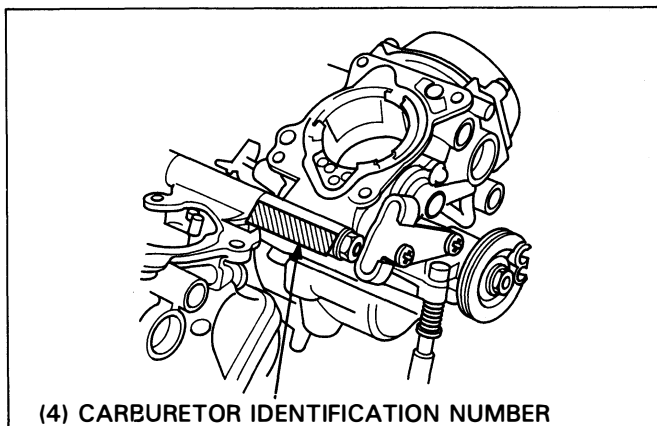

(4) The carburetor identification number is stamped on the carburetor body intake side.

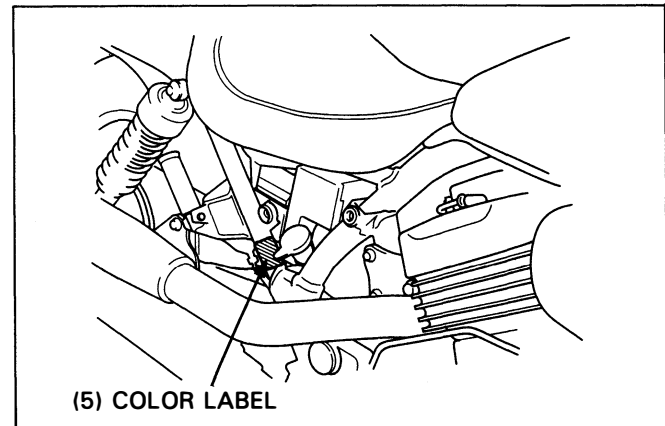

(5) The color label is attached as shown. When ordering color-coded parts, always specify the designated color code.

Specifications

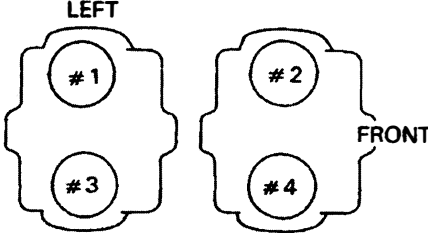
General		Item	Specifications	
Dimensions	Overall length	'94-'00 After '00	2,332 mm (91.8 in) 2,338 mm (92.0 in)	
	Overall width		854 mm (33.6 in)	
	Overall height	(VF750C) (VF750CD)	1,136 mm (44.7 in) 1,190 mm (46.9 in)	
	Wheelbase		1,652 mm (65 in)	
	Seat height		710 mm (28 in)	
	Footpeg height		290 mm (11.4 in)	
	Group clearance		155 mm (6.1 in)	
	Dry weight	(VF750C: 49 states, Canadian type) (VF750C: California type) (VF750CD: 49 states, Canadian type) (VF750CD: California type)	229 kg (505 lbs) 231 kg (509 lbs) 230 kg (507 lbs) 232 kg (511 lbs)	
	Curb weight	(VF750C: 49 states, Canadian type) (VF750C: California type) (VF750CD: 49 states, Canadian type) (VF750CD: California type)	247 kg (545 lbs) 249 kg (549 lbs) 248 kg (547 lbs) 250 kg (551 lbs)	
	Maximum weight capacity		180 kg (397 lbs)	
	Frame	Frame type		Double cradle
		Front suspension		Telescopic fork
		Front wheel travel		150 mm (5.91 in)
		Rear suspension		Swingarm
		Rear wheel travel		100 mm (3.94 in)
Rear damper			Double effect type	
Front tire size			120/80 - 17M/C 61V	
Rear tire size			150/80 - 15M/C 70V	
Tire brand (Front/Rear)			K555F/K555 (Dunlop)	
Front brake			Hydraulic brake	
Rear brake			Internal expanding shoe	
Caster angle			32°	
Trail length			137 mm (5.39 in)	
Fuel tank capacity		13.9 liter (3.7 US gal, 3.1 Imp gal)		
Fuel tank reserve capacity		3.3 liter (0.87 US gal, 0.37 Imp gal)		
Engine	Bore and stroke		70.0 x 48.6 mm (2.76 x 1.91 in)	
	Displacement		748.1 cc (45.65 cu-in)	
	Compression ratio		10.8 : 1	
	Valve train		Silent multi-link chain drive and DOHC	
	Intake valve opens (at 1 mm lift)		10° BTDC	
	Intake valve closes (at 1 mm lift)		25° ABDC	
	Exhaust valve opens (at 1 mm lift)		35° BBDC	
	Exhaust valve closes (at 1 mm lift)		-5° ATDC	
	Lubrication system		Forced pressure and wet sump	
	Oil pump type		Trochoid	
	Cooling system		Liquid cooled	
	Air filtration		Paper filter	
	Crankshaft type		Unit-type, 4 main journal	
	Engine dry weight		80.3 kg (177 lbs)	
Firing order		1 - 90° - 4 - 270° - 3 - 90° - 2 - 270° - 1		
Cylinder arrangement		4 cylinder 90° V		
Cylinder number				

General (Cont'd)		
	Item	Specifications
Carburetor	Carburetor type Venturi diameter	CV (Constant Velocity) type, with flat valve 33 mm (1.30 in)
Drive Train	Clutch system Clutch operation system Transmission Primary reduction Secondary reduction Third reduction Final reduction Gear ratio 1st Gear ratio 2nd Gear ratio 3rd Gear ratio 4th Gear ratio 5th Gear ratio 6th Gear ratio reverse Gearshift pattern	Multi-plate, wet Cable operating 5 speeds 1.939 (64/33) — — 2.500 (40/16) 2.846 (37/13) 1.882 (32/17) 1.450 (29/20) 1.227 (27/22) 1.035 (29/28) — — Left foot operated return system 1-N-2-3-4-5
Electrical	Ignition system Starting system Charging system Regulator/rectifier type Lighting system AC regulator type	Full transistor ignition Starter motor Triple phase output alternator SCR shorted/triple phase, full-wave rectification Battery —

General Information

Unit: mm (in)

Lubrication	Item	Standard	Service Limit
	Engine oil capacity at draining at disassembly at oil filter change	3.0 lit (3.2 US qt, 2.6 Imp qt) 3.8 lit (4.0 US qt, 3.3 Imp qt) 3.1 lit (3.3 US qt, 2.7 Imp qt)	— — —
	Recommended engine oil	Use Honda GN4 4-stroke Oil or equivalent API Service Classification: SF or SG Viscosity: SAE 10W-40	
	<p style="text-align: center;">OIL VISCOSITIES</p>	Other viscosities shown in the chart may be used when the average temperature in your riding area is within the indicated range.	
	Oil pressure at oil pressure switch	490-588 kPa (5-6 kg/cm ² , 71.1-85.3 psi) at 6,000 rpm (80°C/176°F)	
	Oil pump rotor tip clearance ① body clearance ② end clearance ③	0.10 (0.004) 0.15-0.22 (0.006-0.009) 0.02-0.09 (0.001-0.004)	0.15 (0.006) 0.35 (0.014) 0.10 (0.005)

Fuel System			
Carburetor identification number (49 states type) (California type) (Canadian type)	VP31A VP30A VP32D	— — —	
Main jet	# 102	—	
Slow jet	# 40	—	
Pilot screw initial opening	see page 5-16	—	
Pilot screw high altitude adjustment	see page 5-17	—	
Float level	13.7 (0.54)	—	
Carburetor vacuum difference	Within 20 mmHg (0.8 inHg)	—	
Base carburetor (For carburetor synchronization)	No. 1 carburetor	—	
Idle speed (49 states type)	1,000 ± 100 rpm	—	
(California type)	1,100 ± 100 rpm	—	
(Canadian type)	1,000 ± 100 rpm	—	
Throttle grip free play	2-6 (1/8-1/4)	—	
Pulse secondary air (PAIR) injection system (California type)	PAIR check valves are built in to the PAIR control valve	—	
Pulse secondary air injection control valve vacuum pressure	—	—	

Cooling System		
Cooling capacity (Radiator and engine) (Reserve tank)	2.4 l (0.6 US gal, 0.5 Imp gal) 0.4 l (0.1 US gal, 0.09 Imp gal)	— —
Radiator cap relief pressure	107.9 kPa (1.1 kg/cm ² , 15.64 psi)	—
Thermostat begins to open	80-84°C (176-183°F)	—
Thermostat fully open	95°C (203°F)	—
Thermostat valve lift	8.0 (0.315) min.	—

Unit: mm (in)

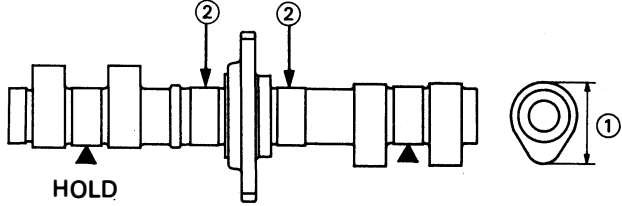
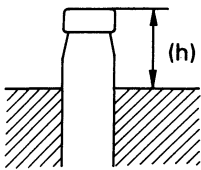
Cylinder Head		Standard	Service Limit
Item			
Cylinder compression		1,275 kPa (184.9 psi, 13.0 kg/cm ²)/ 500 rpm	—
Cylinder compression synchronization difference		—	—
Valve clearance	IN	0.16 ± 0.02 (0.006 ± 0.001)	—
	EX	0.25 ± 0.02 (0.010 ± 0.001)	—
Cylinder head warpage		—	0.10 (0.004)
Cam lobe height ①	IN	35.980–36.140 (1.4165–1.4228)	35.95 (1.4153)
	IN (California type)	—	—
	EX	35.670–35.830 (1.4043–1.4106)	35.64 (1.4031)
	EX (California type)	—	—
Camshaft runout ②		—	0.05 (0.002)
Camshaft oil clearance		0.030–0.072 (0.0012–0.0028)	0.10 (0.004)
			
Camshaft journal O.D.		24.949–24.970 (0.9822–0.9831)	24.94 (0.982)
Camshaft holder I.D.		25.000–25.021 (0.9843–0.9851)	25.05 (0.986)
Valve stem O.D.	IN	4.475–4.490 (0.1762–0.1767)	4.46 (0.175)
	EX	4.465–4.480 (0.4758–0.1764)	4.45 (0.175)
Valve guide I.D.	IN	4.500–4.512 (0.1772–0.1776)	4.56 (0.179)
	EX	4.500–4.512 (0.1772–0.1776)	4.56 (0.179)
Stem-to-guide clearance	IN	0.010–0.037 (0.0004–0.0015)	—
	EX	0.020–0.047 (0.0008–0.0019)	—
Valve guide projection above cylinder head	IN	15.30–15.50 (0.602–0.610)	—
	EX	15.30–15.50 (0.602–0.610)	—
 <p>Before guide installation:</p> <ol style="list-style-type: none"> 1. Chill the valve guides in the freezer section of the refrigerator for about an hour. 2. Heat the cylinder head to 212–300°F (100–150°C) 			
Valve seat width		1.0 (0.04)	1.5 (0.06)
Valve spring free length		37.86 (1.49)	36.1 (1.42)
Valve lifter O.D.		25.978–25.993 (1.0225–1.0233)	25.96 (1.022)
Valve lifter bore I.D.		26.010–26.026 (1.0240–1.0246)	26.04 (1.025)

General Information

Unit: mm (in)

Clutch System	Item	Standard	Service Limit
	Clutch lever free play	10–20 (0.4–0.8)	—
	Clutch outer guide I.D.	24.995–25.012 (0.9841–0.9847)	25.08 (0.987)
	Clutch spring free length	44.4 (1.75)	41.2 (1.62)
	Clutch disc thickness A	2.92–3.08 (0.115–0.121)	2.5 (0.10)
	B (Judder spring side)	2.92–3.08 (0.115–0.121)	2.5 (0.10)
	Clutch palte warpage	—	—

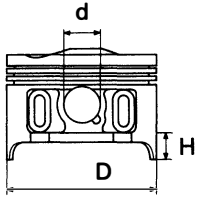
Cylinder/Piston	Item	Standard	Service Limit
	Cylinder I.D.	70.000–70.015 (2.755–2.756)	70.10 (2.759)
	Cylinder out of round	—	0.10 (0.004)
	Cylinder taper	—	0.10 (0.004)
	Cylinder warpage	—	0.10 (0.004)
	Piston mark direction	With "IN" mark facing to the intake side	—
	Piston O.D. (D)	69.970–69.990 (2.755–2.756)	69.85 (2.750)
	Piston O.D. measurement point (H)	10 (0.4)	—
	Piston pin hole O.D. (d)	17.002–17.008 (0.6694–0.6695)	17.02 (0.670)
			
	Cylinder-to-piston clearance	0.010–0.035 (0.0004–0.0014)	—
	Piston pin O.D.	16.994–17.000 (0.6691–0.6693)	16.98 (0.669)
	Piston-to-piston pin clearance	0.002–0.014 (0.0001–0.0005)	—
	Connecting rod-to-piston clearance	0.016–0.040 (0.0006–0.0016)	—
	Top ring-to-ring groove clearance	0.015–0.050 (0.0006–0.0019)	0.10 (0.04)
	Second ring-to-ring groove clearance	0.015–0.045 (0.0006–0.0018)	0.10 (0.004)
	Top ring end gap	0.20–0.35 (0.008–0.014)	0.5 (0.02)
	Second ring end gap	0.35–0.50 (0.014–0.020)	0.7 (0.03)
	Oil ring (side rail) end gap	0.20–0.80 (0.008–0.031)	1.00 (0.039)
	Top ring mark	Install with the marked side up	—
	Second ring mark	Install with the marked side up	—

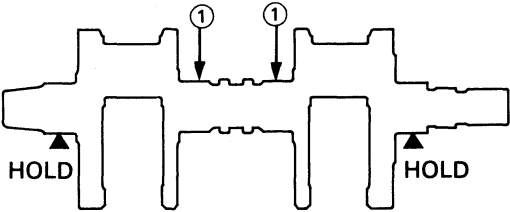
Crankshaft	Item	Standard	Service Limit
	Connecting rod small end I.D.	17.016–17.043 (0.6699–0.6706)	17.04 (0.671)
	Connecting rod big end side clearance radial clearance	0.10–0.30 (0.004–0.012)	0.40 (0.016)
	Crankshaft runout ①	—	0.05 (0.002)
			
	Crankpin oil clearance	0.030–0.052 (0.0012–0.0020)	0.08 (0.003)
	Connecting rod bearing selection	See page 11-9	—
	Main journal oil clearance	0.019–0.037 (0.0007–0.0015)	0.05 (0.019)
	Main journal bearing selection	See page 11-8	—

Unit: mm (in)

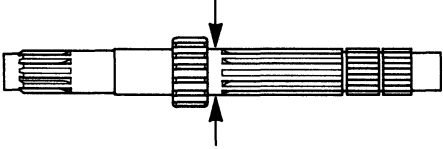
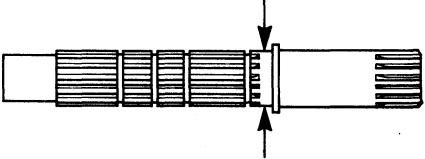
Transmission	Item	Standard	Service Limit
	Transmission gear I.D. M5	28.000–28.021 (1.1024–1.1032)	28.04 (1.104)
	C2	31.000–31.016 (1.2205–1.2211)	31.04 (1.222)
	C3	31.000–31.016 (1.2205–1.2211)	31.04 (1.222)
	C4	31.000–31.016 (1.2205–1.2211)	31.04 (1.222)
	Transmission gear bushing O.D. M5	27.959–27.980 (1.1007–1.1016)	27.94 (1.010)
	C2	30.970–30.995 (1.2193–1.2203)	30.95 (1.219)
	C3	30.950–30.975 (1.2185–1.2195)	30.93 (1.218)
	C4	30.950–30.975 (1.2185–1.2195)	30.93 (1.218)
	Transmission gear bushing I.D. M5	24.985–25.006 (0.9834–0.9845)	27.94 (1.010)
	C2	28.000–28.021 (1.1024–1.1032)	28.04 (1.104)
	C3	27.995–28.016 (1.1022–1.1029)	28.04 (1.104)
	Gear-to-bushing clearance at M5 gear	0.020–0.062 (0.0008–0.0024)	—
	at C2 gear	0.005–0.046 (0.0002–0.018)	—
	at C3 gear	0.025–0.066 (0.0001–0.0026)	—
	at C4 gear	0.025–0.066 (0.0001–0.0026)	—
	Mainshaft O.D. at M5 gear bushing	24.959–24.980 (0.9826–0.9835)	24.95 (0.982)
			
	Countershaft O.D. at C2 gear bushing	27.967–27.980 (1.1011–1.1016)	27.96 (1.101)
			
	Gear-to-shaft clearance	—	—
	Gear bushing-to-shaft clearance at M5 gear	0.005–0.047 (0.0002–0.0019)	—
	at C2 gear	0.020–0.054 (0.0008–0.0021)	—
	at C3 gear	0.015–0.049 (0.0006–0.0019)	—
	at C4 gear	0.015–0.049 (0.0006–0.0019)	—
	Shift fork claw thickness L	6.43–6.50 (0.253–0.256)	6.40 (0.252)
	C	6.43–6.50 (0.253–0.256)	6.40 (0.252)
	R	6.43–6.50 (0.253–0.256)	6.40 (0.252)
	Shift fork I.D. L	14.016–14.034 (0.5518–0.5525)	14.043 (0.5529)
	C	14.016–14.034 (0.5518–0.5525)	14.043 (0.5529)
	R	14.016–14.034 (0.5518–0.5525)	14.043 (0.5529)
	Shift fork shaft O.D.	13.973–13.984 (0.5501–0.5506)	13.965 (0.5498)

Wheel/Tires	Item	Standard	Service Limit
	Minimum tire tread depth (FR)	—	1.5 (0.06)
	(RR)	—	2.0 (0.08)
	Cold tire pressure Up to 90 kg (200 lb) load (FR)	250 kPa (2.50 kg/cm ² , 36 psi)	—
	Up to 90 kg (200 lb) load (RR)	250 kPa (2.50 kg/cm ² , 36 psi)	—
	Up to maximum weight capacity (FR)	250 kPa (2.50 kg/cm ² , 36 psi)	—
	Up to maximum weight capacity (RR)	290 kPa (2.90 kg/cm ² , 42 psi)	—
	Front and rear axle runout	—	0.2 (0.01)
	Front and rear wheel rim runout (Radial)	—	2.0 (0.08)
	(Axial)	—	2.0 (0.08)
	Wheel balance weight (Front)	—	60 g (2.1 oz)
	(Rear)	—	60 g (2.1 oz)
	Drive chain slack	20–30 (3/4–1-3/16)	—
	Drive chain size/link (DID)	DID 50V4/118	—
	(RK)	RK 50 MFOZ1/118	—

Front Suspension	Item	Standard	Service Limit
	Fork spring free length	410.7 (16.17)	402.5 (15.85)
	Fork spring direction	Tapered coil facing down	—
	Fork tube runout	—	0.2 (0.01)
	Recommended fork oil	Fork fluid	—
	Fork oil level	122 (4.80)	—
	Fork oil capacity	521cc (17.62 US oz, 18.29 Imp oz)	—
	Steering bearing preload	0.1–0.15 kg-m	—

Rear Suspension	Item	Standard	Service Limit
	Shock absorber spring free length	241.8 (9.52)	237.0 (9.33)
	Shock absorber spring adjuster standard position	2nd groove	—
	Shock absorber spring direction	Small coil end facing down	—

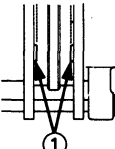
Brakes	Item	Standard	Service Limit
Front	brake fluid	DOT 4	—
	brake pad wear indicator ①	—	To the groove
			
	brake disc thickness	6.0 (0.24)	5.0 (0.20)
	brake disc runout	—	0.25 (0.01)
	master cylinder I.D.	11.0–11.043 (0.4331–0.4348)	11.055 (0.4352)
	master piston O.D.	10.957–10.984 (0.4314–0.4324)	10.945 (0.4309)
	caliper cylinder I.D.	25.400–25.450 (1.000–1.0020)	25.461 (1.002)
	caliper piston O.D.	25.335–25.368 (0.9974–0.9987)	25.33 (0.997)
Rear	brake pedal free play	20–30 (0.8–1.2)	—
	brake drum I.D.	180–180.3 (7.086–7.098)	181 (7.12)
	brake lining thickness	5.0 (0.2)	2.0 (0.08)

Unit: mm (in)

Battery/Charging System		
Item	Standard	Service Limit
Alternator/charging coil resistance (at 20°C/68°F)	0.1–1.0 Ω	—
Regulator/rectifier regulated voltage/amperage	14–15.5 V/below 0.5 A/3,000 rpm	—
Battery capacity	12 V–10 Ah	—
Battery charging rate (Normal)	1.2 A (5–10h)	—
(Quick)	5 A (1h)	—
Battery voltage (fully charged 20°C/68°F)	Over 13.1 V	—
(needs charging 20°C/68°F)	Below 12.5 V	—

Ignition System		
Spark plug		
(Standard NGK)	CR8EH9	—
(Standard NIPPONDENSO)	U24FER9	—
(For cold climate/below 5°C/41°F NGK)	—	—
(For cold climate/below 5°C/41°F NIPPONDENSO)	—	—
(For extended high speed riding NGK)	CR9EH9	—
(For extended high speed riding NIPPONDENSO)	U27FER9	—
Spark plug gap	0.8–0.9 (0.03–0.04)	—
Ignition timing "F" mark	12° BTDC at idle	—
Advance start	2,000 rpm	—
stop	—	—
Full advance	—	—
Ignition coil resistance (Primary: at 20°C/68°F)	2–4 Ω	—
(Secondary with plug cap)	23–27 kΩ	—
(Secondary without plug wire)	13–17 kΩ	—
Pulse generator resistance (At 20°C/68°F)	450–550 Ω	—

Starter System		
Starter motor brush length	12.0–13.0 (0.47–0.51)	6.5 (0.26)
Starter clutch driven gear O.D.	47.175–47.200 (1.8573–1.8583)	47.16 (1.857)

Lights/Meters/Switches		
Main fuse	30 A	—
Fuse	10 A x 3, 15 A x 1	—
Headlight (high/low beam)	12 V 60/55 W	—
Tail/brake light	12 V 32/3 cp	—
Position light bulb	12 V 3 cp x 2	—
Front turn signal lights	12 V 32/3 cp x 2	—
Rear turn signal lights	12 V 32 cp x 2	—
Instrument lights	12 V 1.7 W x 1, 12 V 1.4 W x 2	—
Oil pressure warning indicator	12 V 3 W	—
Side stand indicator	12 V 3 W	—
Coolant temperature indicator	12 V 3 W	—
High beam indicator	12 V 3 W	—
Turn signal indicator	12 V 3 W	—
Neutral indicator	12 V 3 W	—
Coolant temperature sensor resistance	85°C (185°F) 39–49 Ω	—
	120°C (248°F) 14–18 Ω	—
Fan motor switch	Starts to close (ON) 97–103°C (207–217°F)	—
	Stops to open (OFF) 92–98°C (198–208°F)	—

Torque Values

Standard			
Fasteners Type	Torque N·m (kg-m, ft-lb)	Fasteners Type	Torque N·m (kg-m, ft-lb)
5 mm hex bolt and nut	5 (0.5, 3.5)	5 mm screw	4 (0.4, 3)
6 mm hex bolt and nut	10 (1.0, 7)	6 mm screw	9 (0.9, 7)
8 mm hex bolt and nut	22 (2.2, 16)	6 mm flange bolt (8 mm head)	9 (0.9, 7)
10 mm hex bolt and nut	35 (3.5, 25)	6 mm flange bolt (10 mm head) and nut	12 (1.2, 9)
12 mm hex bolt and nut	55 (5.5, 40)	8 mm flange bolt and nut	27 (2.7, 20)
		10 mm flange bolt and nut	40 (4.0, 29)

Torque specifications listed below are for important fasteners. Others should be tightened to standard torque values listed above.

- Notes:
1. Apply sealant to the threads.
 2. Apply a locking agent to the threads.
 3. Apply molybdenum disulfide oil to the threads and flange surface.
 4. Left hand threads.
 5. Stake.
 6. Apply oil to the threads and flange surface.
 7. Apply clean engine oil to the O-ring.
 8. Torque wrench scale reading using a special tool.
 9. Apply grease to the threads and flange surface.
 10. UBS bolt.
 11. U-nut.
 12. ALOC bolt; Replace with a new one.

Engine				
Item	Q'ty	Thread dia. (mm)	Torque N·m (kg-m, ft-lb)	Remarks
Maintenance:				
Timing hole cap	1	45	18 (1.8, 13)	Note 9
Lubrication:				
Oil pressure switch	1	PT 1/8	12 (1.2, 9)	Note 1
Oil filter	1	20	10 (1.0, 7)	Note 6
Oil filter stud bolt	1	20	18 (1.8, 13)	Note 2
Oil drain bolt	1	12	34 (3.4, 25)	
Oil pump bolt	3	6	13 (1.3, 9)	
Oil pump driven sprocket bolt	1	6	18 (1.8, 13)	Note 2
Oil pipe nut (After '94)	1	6	12 (1.2, 9)	Note 11
Fuel Systems:				
Connecting tube band screw	4	5	1 (0.1, 0.7)	
Cooling Systems:				
Water pump cover	2	6	13 (1.3, 9)	
Water pump mounting bolt	2	6	13 (1.3, 9)	
Cylinder Head:				
Spark plug	4	10	12 (1.2, 9)	
Head cover protector	8	6	10 (1.0, 7)	
Cylinder head cover bolt	8	6	10 (1.0, 7)	
Breather case bolt	6	6	10 (1.0, 7)	
Cylinder head protector bolt	12	6	12 (1.2, 9)	
Cylinder head sealing bolt	4	18	44 (4.4, 32)	Note 2
Cylinder head bolt (9 mm)	16	9	44 (4.4, 32)	Note 6
Cylinder head bolt (6 mm)	4	6	12 (1.2, 9)	
Camshaft holder bolt	32	6	12 (1.2, 9)	Note 6
Cam chain tensioner mounting bolt	4	6	12 (1.2, 9)	
Boost joint bolt	—	5	4 (0.4, 2.9)	

Engine				
Item	Q'ty	Thread dia. (mm)	Torque N·m (kg-m, ft-lb)	Remarks
Clutch/Gearshift Linkage				
Right crankcase cover bolt	13	6	12 (1.2, 9)	
Clutch cable holder bolt	1	10	23 (2.3, 17)	
Clutch spring bolt	5	6	12 (1.2, 9)	
Clutch center lock nut ('94)	1	22	90 (9.0, 65)	Note 5, 6
(After '94)	1	22	110 (11.0, 80)	Note 5, 6
Gearshift link joint bolt	1	6	9 (0.9, 6.5)	
Change pedal pivot bolt	1	8	27 (2.7, 20)	
Drive sprocket cover bolt	3	6	10 (1.0, 7)	
Drive sprocket cover rubber bolt	2	6	12 (1.2, 9)	
Drive sprocket bolt	1	10	51 (5.1, 37)	
Shift drum center bolt	1	8	23 (2.3, 17)	Note 2
Shift return spring pin	1	8	23 (2.3, 17)	
Crankcase/Crankshaft:				
Upper crankcase bolt (10 mm)	2	10	39 (3.9, 28)	
Upper crankcase bolt (6 mm)	7	6	12 (1.2, 9)	
Lower crankcase bolt (9 mm)	8	9	31 (3.1, 22)	Note 6
Lower crankcase bolt (8 mm)	1	8	23 (2.3, 17)	
Lower crankcase bolt (6 mm)	8	6	12 (1.2, 9)	
Cam chain tensioner slipper bolt	2	6	12 (1.2, 9)	Note 2
Cam chain slipper bolt	2	6	12 (1.2, 9)	Note 2
Connecting rod bearing cap nut	8	8	33 (3.3, 24)	Note 6
Sealing bolt	1	8	18 (1.8, 13)	Note 2
Alternator:				
Left crankcase cover bolt	6	6	12 (1.2, 9)	
Flywheel bolt	1	10	83 (8.3, 61)	Note 6
Stator mounting bolt	3	6	12 (1.2, 9)	
Ignition System:				
Pulse generator mounting bolt	3	6	10 (1.0, 7)	
Starter Clutch:				
Starter motor flange nut	1	6	10 (1.0, 7)	
Starter motor case bolt	2	5	5 (0.5, 3.6)	
Starter clutch bolt	1	12	90 (9.0, 65)	Note 6
Starter clutch outer cover bolt	3	8	40 (4.0, 29)	Note 2
Lights/Meters/Switches:				
Neutral switch	1	10	12 (1.2, 9)	

Frame				
Item	Q'ty	Thread dia. (mm)	Torque N·m (kg-m, ft-lb)	Remarks
Engine mounting:				
Front cylinder head mounting bolt	2	10	54 (5.4, 39)	
Front engine mounting bracket bolt	4	8	39 (3.9, 28)	
Front engine mounting bolt	2	10	44 (4.4, 32)	
Rear engine mounting bracket bolt	2	8	39 (3.9, 28)	
Rear engine mounting bolt	1	12	64 (6.4, 46)	Note 9
Rear cylinder head mount bolt	2	10	44 (4.4, 32)	
Rear cylinder head mount bracket bolt	4	8	39 (3.8, 28)	

General Information

Frame	Item	Q'ty	Thread dia. (mm)	Torque N·m (kg·m, ft·lb)	Remarks
Front Suspension:					
	Handlebar upper holder bolt	4	6	23 (2.3, 17)	
	Front fender bolt	4	6	12 (1.2, 9)	
	Steering stem nut	1	24	105 (10.5, 76)	page 12-12
	Lock nut	1	26		
	Steering head bearing adjusting nut	1	26	30 (3.0, 22)	
	Fork pinch bolt (upper)	2	8	27 (2.7, 20)	
	(lower)	2	10	39 (3.9, 28)	
	Fork cap	2	37	23 (2.3, 17)	
	Fork socket bolt	2	8	20 (2.0, 14)	Note 2
	Fork drain bolt	2	6	8 (0.8, 5.8)	
Rear Suspension:					
	Frame pivot adjusting bolt	1	20	15 (1.5, 11)	page 13-10
	Frame lock nut	1	20	64 (6.4, 46)	
	Frame lock bolt	1	10	39 (3.9, 28)	
	Swingarm pivot nut	1	14	89 (8.9, 65)	Note 11
	Chain slider screw	2	5	6 (0.6, 4.3)	
	Chain tensioner	2	8	22 (2.2, 16)	
	Shock absorber mounting bolt (upper)	2	8	27 (2.7, 20)	
	(lower)	2	10	37 (3.7, 27)	
Wheels:					
	Speedometer cable screw	1	5	4 (0.4, 2.9)	
	Rear axle nut	1	18	93 (9.3, 63)	Note 11
	Front axle bolt	1	14	59 (5.9, 43)	
	Axle pinch bolt	4	8	22 (2.2, 16)	
	Brake disc bolt	6	8	42 (4.2, 30)	Note 12
	Driven sprocket nut	5	12	108 (10.8, 79)	Note 11
Brake System:					
	Brake hose bolt	2	10	35 (3.5, 25)	
	Caliper bracket bolt	2	8	31 (3.1, 22)	Note 12
	Front brake hose clamp nut	2	6	12 (1.2, 9)	Note 11
	Front master cylinder holder bolt	2	6	12 (1.2, 9)	
	Front master cylinder reservoir cover screw	2	4	1.5 (0.15, 1.1)	
	Front brake light switch screw	1	4	1.2 (0.12, 0.9)	
	Front brake lever pivot bolt	1	6	1 (0.1, 0.7)	
	nut	1	6	6 (0.6, 4.3)	
	Pad pin plug	1	10	2.5 (0.25, 1.8)	
	Pad pin	1	10	18 (1.8, 13)	
	Brake caliper bleeder bolt	1	8	5.5 (0.55, 4)	
	Brake caliper bracket pin bolt	1	8	13 (1.3, 9)	Note 2
	Brake caliper pin bolt	1	8	23 (2.3, 17)	Note 2
	Rear brake pedal pivot bolt	1	10	39 (3.9, 28)	
	Rear brake pedal linkage joint pinch bolt	1	8	27 (2.7, 20)	
	Rear brake arm pinch bolt	1	8	29 (2.9, 21)	Note 12
	Rear brake stopper arm nut	2	8	22 (2.2, 16)	
Frame/Exhaust Systems:					
	Exhaust pipe joint nut	8	8	12 (1.2, 9)	
	Exhaust pipe band bolt	4	8	21 (2.1, 15)	
	Exhaust pipe protector bolt	6	6	12 (1.2, 9)	
	Muffler mounting bolt	2	8	27 (2.7, 20)	
Lights/Meters/Switches:					
	Side stand pivot bolt	1	10	10 (1.0, 7)	
	nut	1	10	30 (3.0, 22)	
	Side stand switch	1	6	10 (1.0, 7)	
Others:					
	Footpeg bracket bolt	4	8	27 (2.7, 20)	
	Fuel valve	1	22	23 (2.3, 17)	

Tools

Description	Tool Number	Applicability
Maintenance:		
Oil filter wrench	07HAA—PJ70100	
Drive chain cutter	07HMH—MR10102 or 07HMH—MR1010B	U.S.A. only
Link plate holder	07NMH—MW00110 or 07PMH—MZ20110	
Lubrication:		
Oil pressure gauge	07506—3000000	
Oil pressure gauge attachment	07510—4220100	
Fuel System:		
Float level gauge	07401—0010000	
Pilot screw wrench (Canadian type)	07908—4220201	
(49 states, California type)	07MMA—MV9010A	
Cylinder Head/Cylinder/Piston:		
Valve spring compressor	07757—0010000	
Valve spring compressor attachment	07959—KM30101	
Tappet hole protector	07HMG—MR70002	Not available in U.S.A.
Valve guide driver	07HMD—ML00101	
Valve guide reamer, 4.5 mm	07HMH—ML00101	
Valve seat cutter		
seat cutter, 24.5 mm (45° EX)	07780—0010100	
29 mm (45° IN)	07780—0010300	
flat cutter, 25 mm (32° EX)	07780—0012000	
30 mm (32° IN)	07780—0012200	
interior cutter, 26 mm (60° EX)	07780—0014500	
30 mm (60° IN)	07780—0014000	
cutter holder, 4.5 mm	07781—0010600	
Compression gauge attachment	07JMJ—KY20100	
Tensioner stopper	07NMG—MY90100	Not available in U.S.A.
Clutch/Gearshift Linkage:		
Lock nut wrench, 26 x 30 mm	07716—0020203	'94 only
Extension bar	07716—0020500	'94 only
Clutch center holder	07724—0050001	Equivalent commercially available in U.S.A.
Crankshaft/Transmission:		
Universal bearing puller	07631—0010000	
Inner driver C	07746—0030100	
Attachment, I.D. 25 mm	07746—0030200	
Front Wheel/Suspension/Steering:		
Bearing remover shaft	07746—0050100	
Bearing remover head, 20 mm	07746—0050600	
Attachment, 42 x 47 mm	07746—0010300	
Pilot, 20 mm	07746—0040500	
Fork seal driver	07947—KA50100	
Fork seal driver attachment	07947—KF00100	
Steering stem socket wrench	07916—3710101	
Ball race remover	07953—MJ10000	
— attachment	07953—MJ10100	
	or 07953—MJ1000A	U.S.A. only
— driver handle	07953—MJ10200	
	or M9360—277—91774	U.S.A. only
Ball race remover	07946—3710500	
Attachment, 52 x 55 mm	07746—0010400	
Steering stem driver	07946—MB00000	
Driver	07749—0010000	

General Information

Description	Tool Number	Applicability
Rear Wheel/Suspension:		
Bearing remover shaft	07746-0050100	
Bearing remover head, 20 mm	07746-0050600	
Attachment, 42 x 47 mm	07746-0010300	
Pilot, 20 mm	07746-0040500	
Attachment, 52 x 55 mm	07746-0010400	
Attachment, 62 x 68 mm	07746-0010500	
Pilot, 25 mm	07746-0040600	
Shock absorber compressor	07959-3290001	
Driver shaft	07946-MJ00100	
	or 07949-3710001	U.S.A. only
Attachment, 28 x 30 mm	07946-1870100	
Pilot, 22 mm	07746-0041000	
Attachment, 32 x 35 mm	07746-0010100	
Pilot, 15 mm	07746-0040300	
Needle bearing remover attachment	07GMD-KT70200	
Bearing remover	or M967X-038-XXXXX	U.S.A. only
Attachment, 30 mm	07746-0030300	U.S.A. only
Driver	07749-0010000	
Brake:		
Snap ring pliers	07914-3230001	
Charging System/Alternator:		
Flywheel holder	07725-0040000	
Rotor puller	07733-0020001	
Electric Starter/Starter Clutch:		
Gear holder	07724-0010100	
Electrical Equipment:		
Digital multimeter (KOWA)	07411-0020000	Equivalent commercially available in U.S.A.
Analog tester	07308-0020001 (SANWA) or TH-5H (KOWA)	Not available in U.S.A.

Lubrication & Seal Points

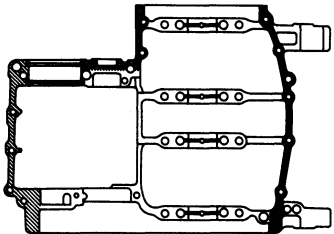
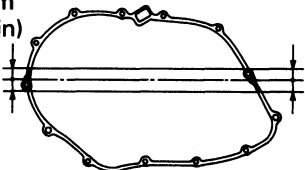
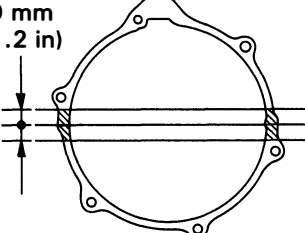
Engine	Location	Material	Remarks
<p>Crankcase mating surface</p>  <p>Right crankcase cover mating surface</p> <p>20–30 mm (0.8–1.2 in)</p>  <p>Left crankcase cover mating surface</p> <p>20–30 mm (0.8–1.2 in)</p>  <p>Cylinder head semi-circular cut-out</p>	<p>Liquid sealant</p>	<ul style="list-style-type: none"> • Wipe off the excess sealant • Do not apply the sealant to near the bearing 	
<p>Crankshaft main bearing thrust surface</p> <p>Connecting rod big end bearing small end</p> <p>Valve stem (valve guide sliding surface)</p> <p>Valve lifter outer sliding surface</p> <p>Camshaft lobes/journals</p> <p>M3/4, C5 and shifter gear (shift fork grooves)</p> <p>Shift fork shaft sliding area</p> <p>Shift drum</p> <p>Primary drive gear sliding area</p> <p>Each gear</p>	<p>Molybdenum disulfide oil (A mixture of 1/2 engine oil and 1/2 molybdenum disulfide grease)</p>		
<p>Cylinder head cover gasket mating surface (cover side)</p>	<p>Honda Bond A</p>		

General Information

Engine Location	Material	Remarks
Right crankcase cover rubber plate bolt threads Drive chain guard bolt threads Crankcase sealing bolt threads Oil pump driven sprocket bolt threads Cam chain tensioner slipper bolt threads Cam chain slipper bolt threads Mainshaft bearing set plate bolt threads Shift drum bearing set plate bolt threads Shift drum center bolt Starter clutch outer cover bolt Oil filter stud bolt threads Cylinder head sealing bolt threads	Locking agent	Clean and apply to the threads Apply area: 5.5–7.5 mm
Oil pressure switch threads Thermo sensor threads	Liquid sealant	
Lower crankcase bolt (9 mm) threads Cylinder head bolt (9 mm) threads and flange surface Camshaft holder bolt (6 mm) threads and flange surface Piston sliding surface pin hole ring Connecting rod bolt and nut threads Starter clutch bolt threads and seating surface Flywheel bolt threads and seating surface Oil filter threads Clutch disc lining surface Clutch center lock nut Each bearing	Engine oil	
Clutch lifter guide Timing hole cap threads Each oil seal lips Each O-ring	Multi-purpose grease	

Frame	Location	Material	Remarks
	Side stand pivot bolt sliding surface Rear brake pedal linkage sliding surface Rear brake pedal pivot surface Rear brake spindle sliding surface Right/left footpeg sliding surface Gearshift pedal pivot surface Throttle pipe sliding surface Clutch lever pivot bolt sliding surface	Multi-purpose grease	Apply thin coat of grease
	Steering head bearings Steering head bearing dust seal lips	'94-'02: Multi-purpose grease After '02: Urea based multi-purpose grease for Extreme pressure (example: EXCELITE EP2 manufactured by KYODO YUSHI, Japan, 'Shell Stamina EP2) Or equivalent	
	Swingarm pivot nut flange surface Swingarm bearings Swingarm dust seal lips Front wheel dust seal lips Rear wheel dust seal lips Rear wheel sliding surface (driven flange) Rear engine mounting nut threads and seating surface Each bearing Each dust seal lips	Multi-purpose grease	
	Throttle cables Choke cable Clutch cable Speedometer cable Steering stem lock nut threads Flywheel bolt threads and flange surface	Engine oil	
	Handle grip inner surface	Honda Bond A	Honda Hand Grip Cement (U.S.A. only)
	Front brake lever pivot and piston tips Brake caliper pin bolt sliding surface Brake caliper bracket pin bolt sliding surface Brake cam sliding surface Brake anchor pin sliding surface	Silicone grease	
	Brake caliper pin bolt threads Brake caliper bracket pin bolt threads Fork socket bolt threads	Locking agent	Clean and apply to the threads
	Front fork oil seal/dust seal lips Front fork	Fork fluid	
	Brake master cylinder	DOT 4 brake fluid	

Cable & Harness Routing

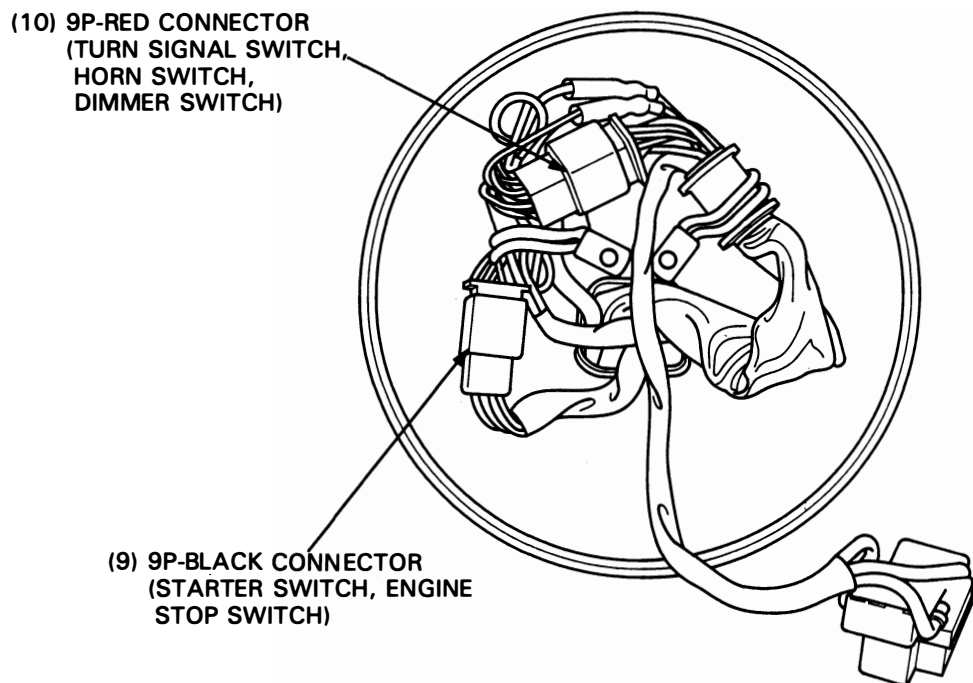
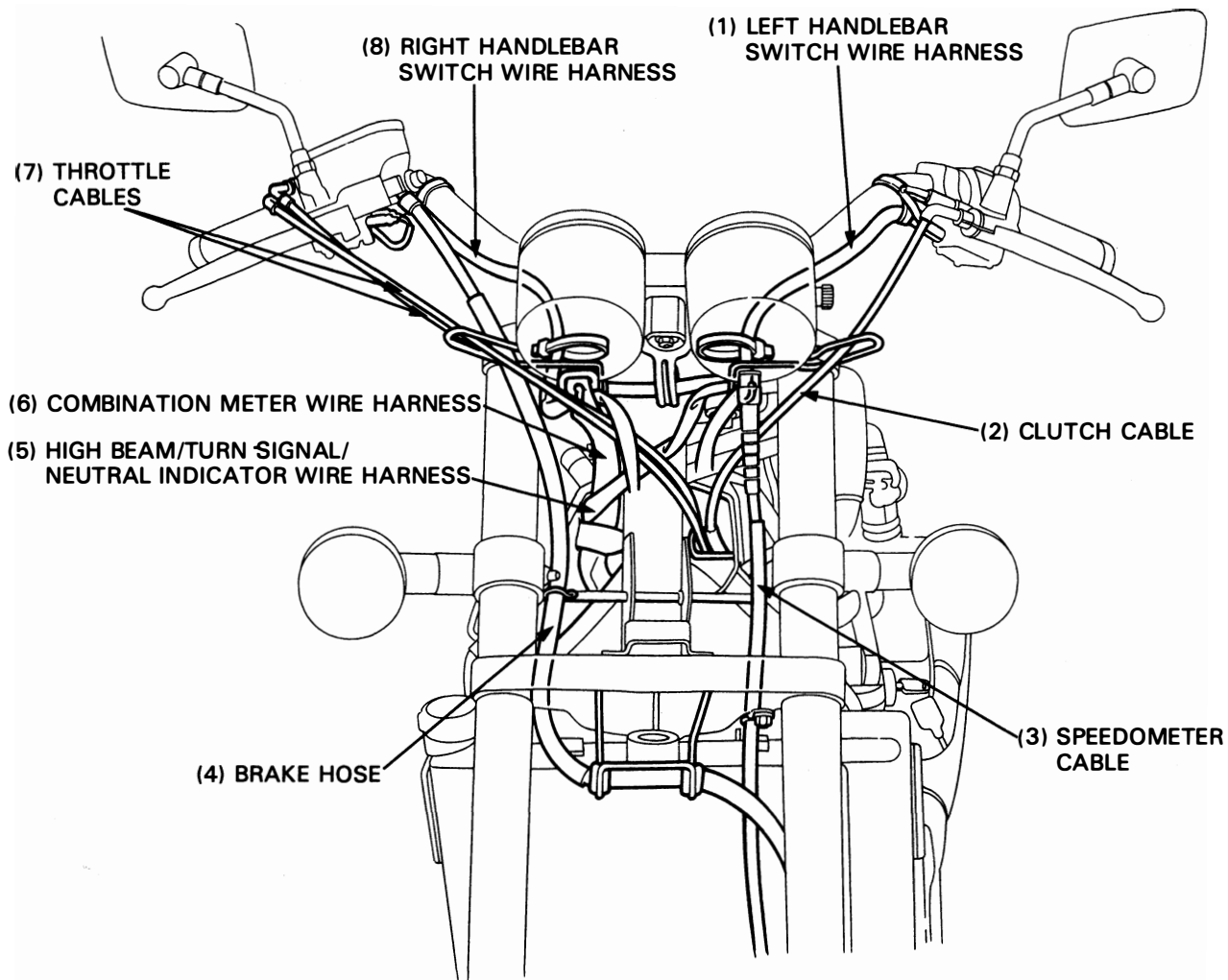

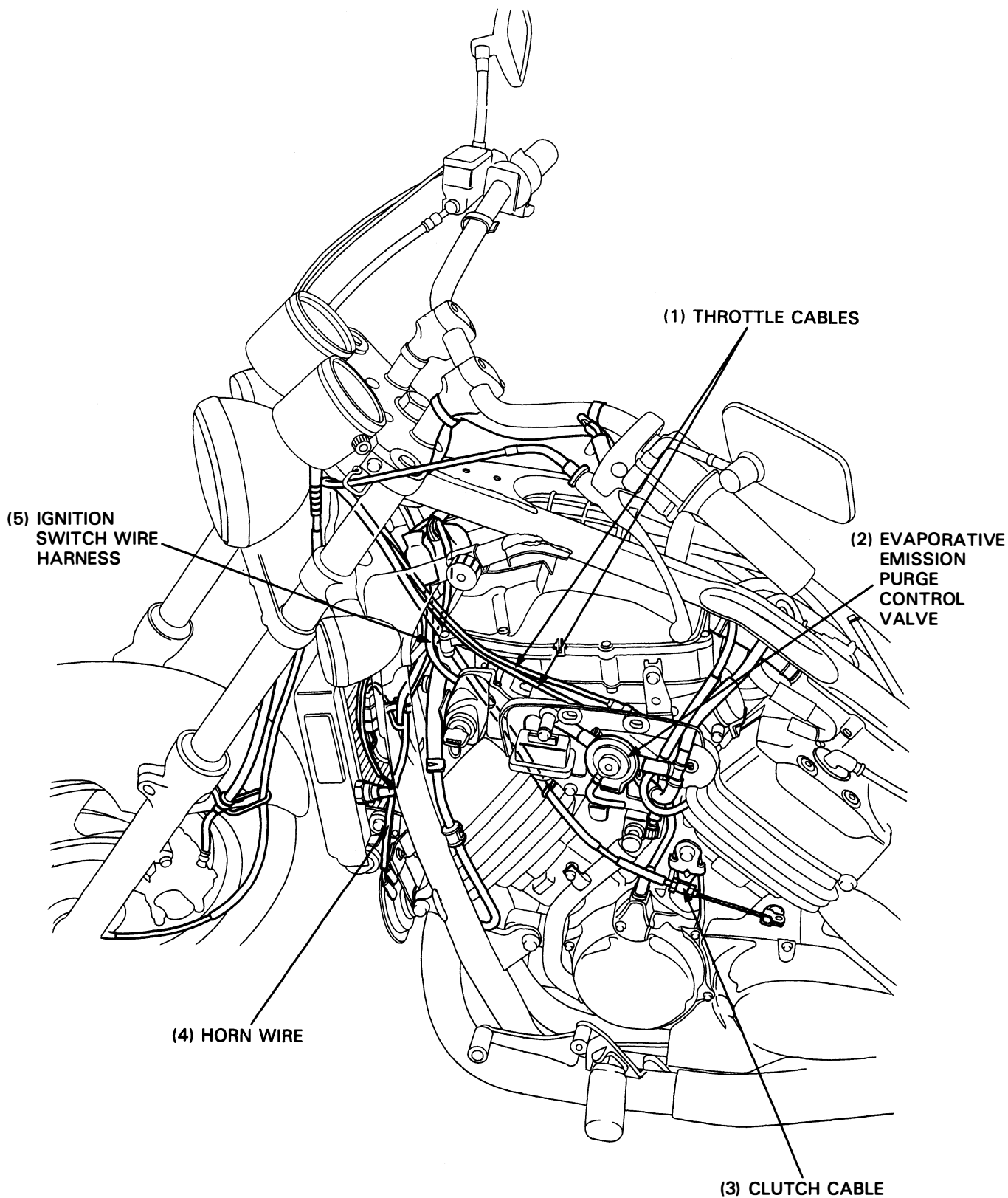

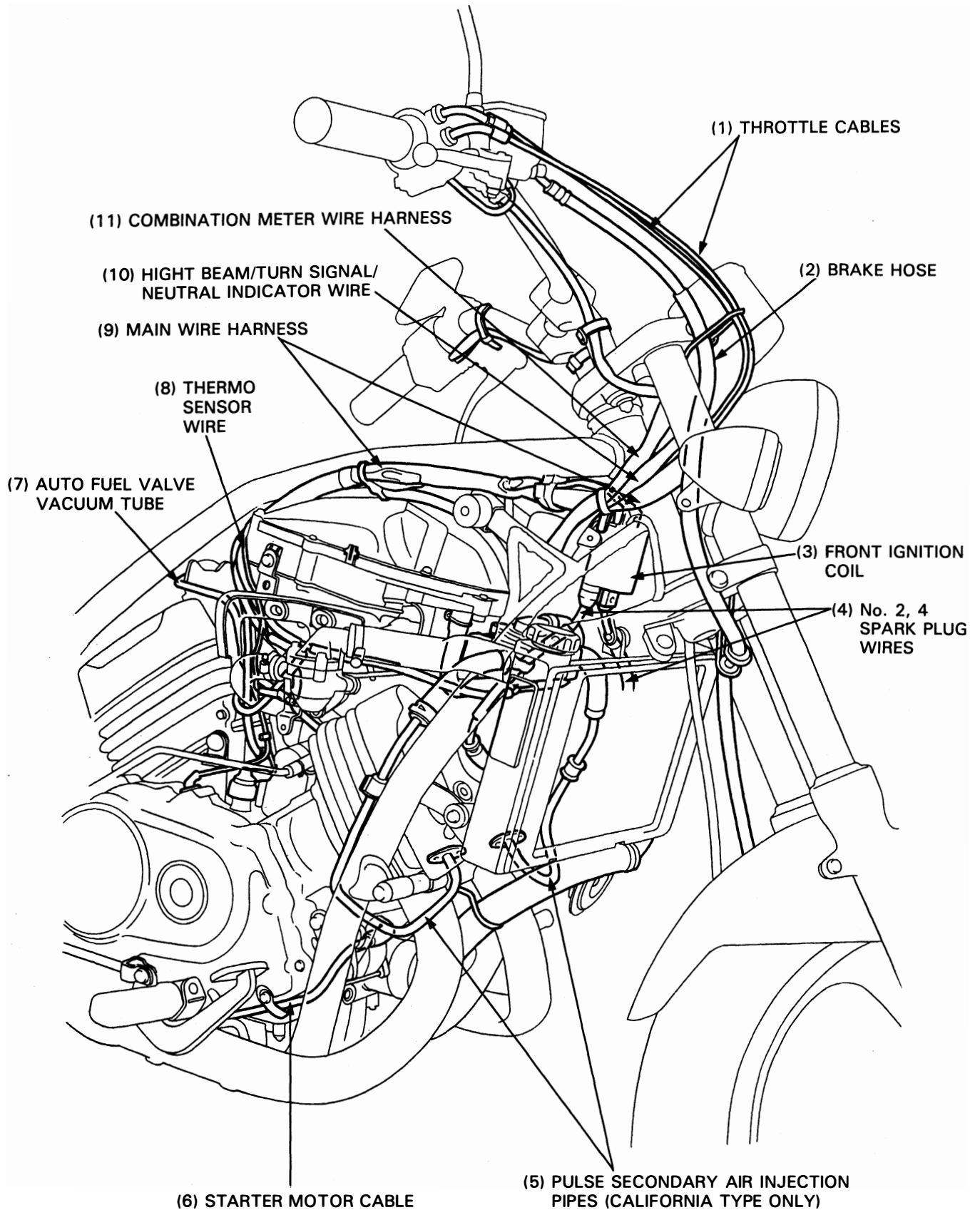

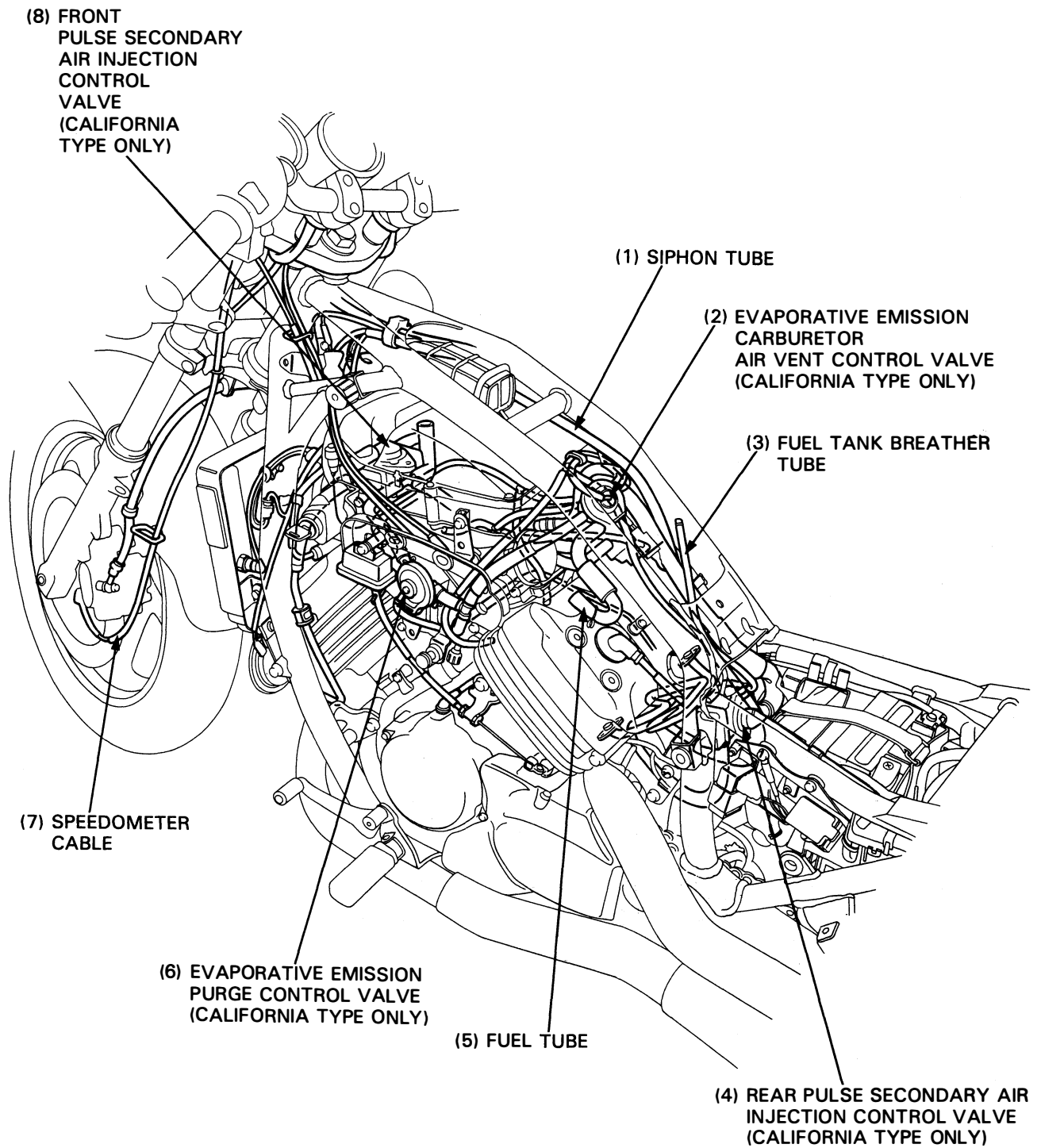

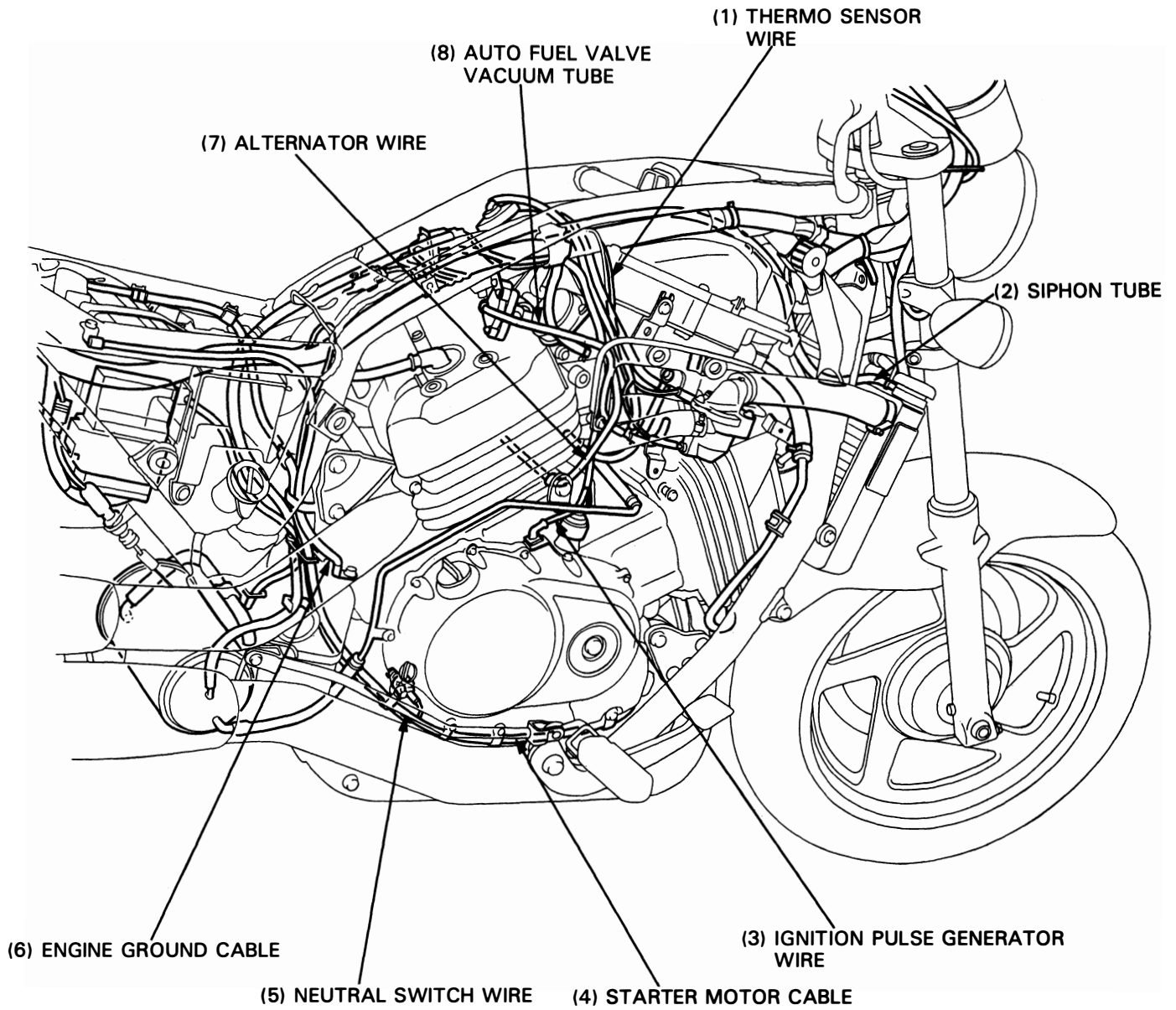

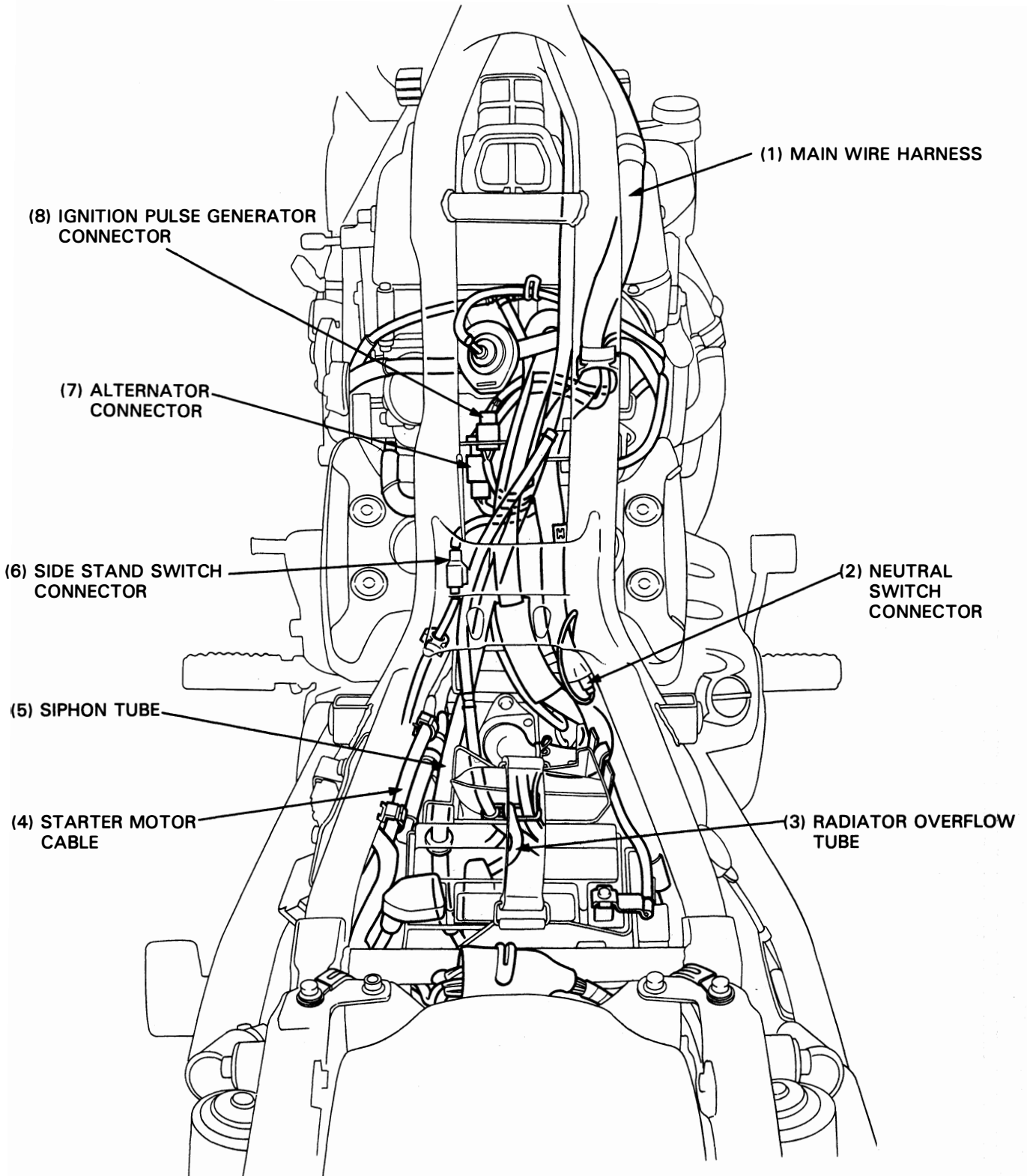

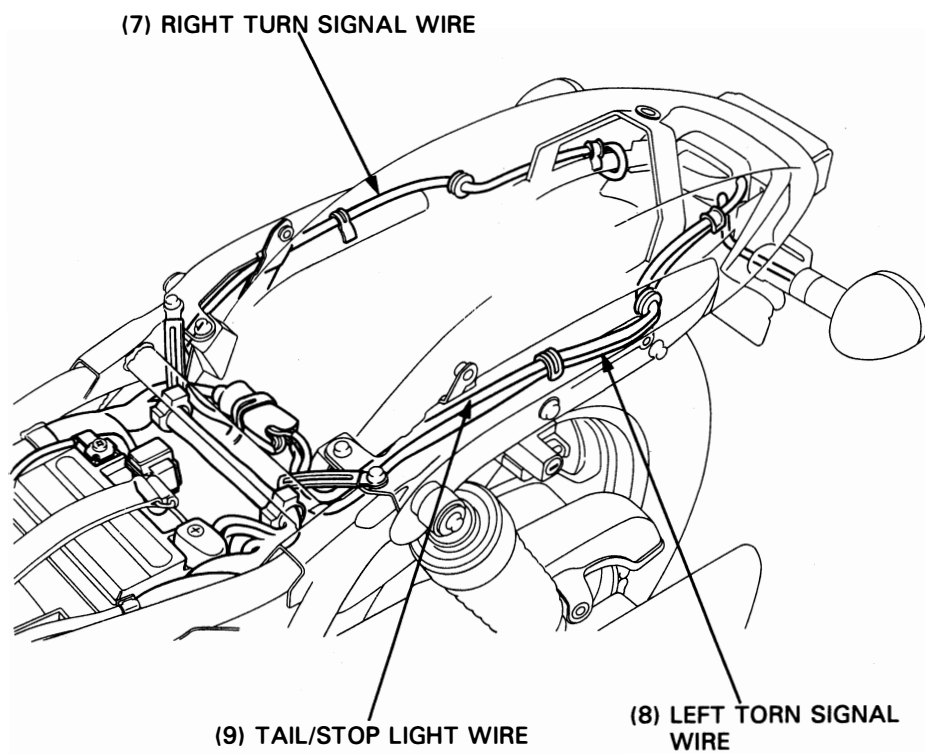
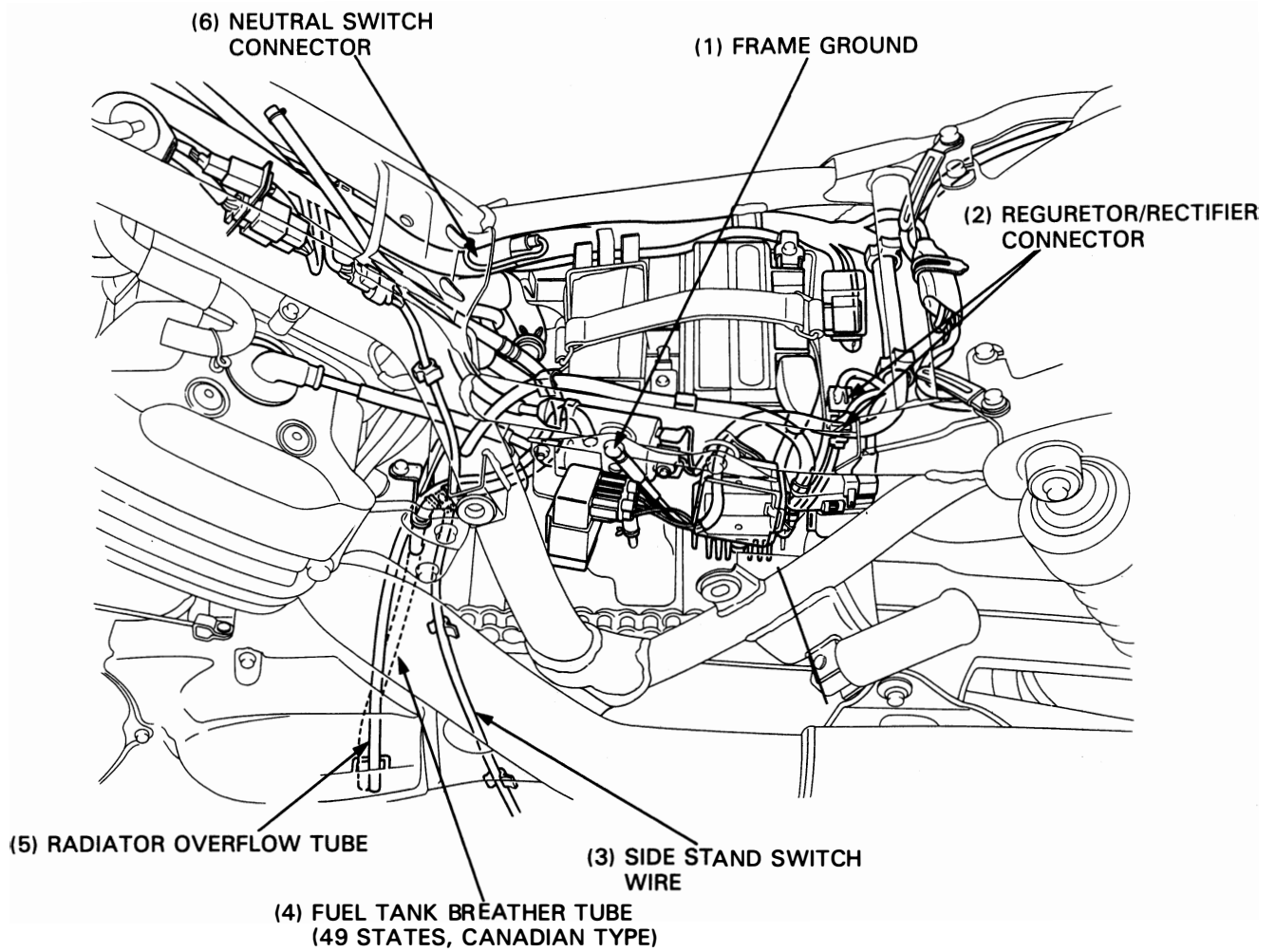

Emission Control System

The U.S. Environmental Protection Agency and California Air Resources Board (CARB) require manufacturers to certify that their motorcycles comply with applicable exhaust emissions standard during their useful life, when operated and maintained according to the instructions provided, and that motorcycles built after January 1, 1983 comply with applicable noise emission standards for 1 year or 6,000 km (3,730 miles) after the time of sale to the ultimate purchaser, when operated and maintained according to the instructions provided. Compliance with the terms of the Distributor's Warranties for Honda Motorcycle Emission Control Systems is necessary in order to keep the emissions system warranty in effect.

Source Of Emissions

The combustion process produces carbon monoxide and hydrocarbons. Control of hydrocarbons is very important because, under certain conditions, they react to form photochemical smog when subjected to sunlight. Carbon monoxide does not react in the same way, but it is toxic.

Honda Motor Co., Ltd. utilizes lean carburetor settings as well as other systems, to reduce carbon monoxide and hydrocarbons.

Crankcase Emission Control System

The crankcase emission control system routes crankcase emissions through the air cleaner and into the combustion chamber.

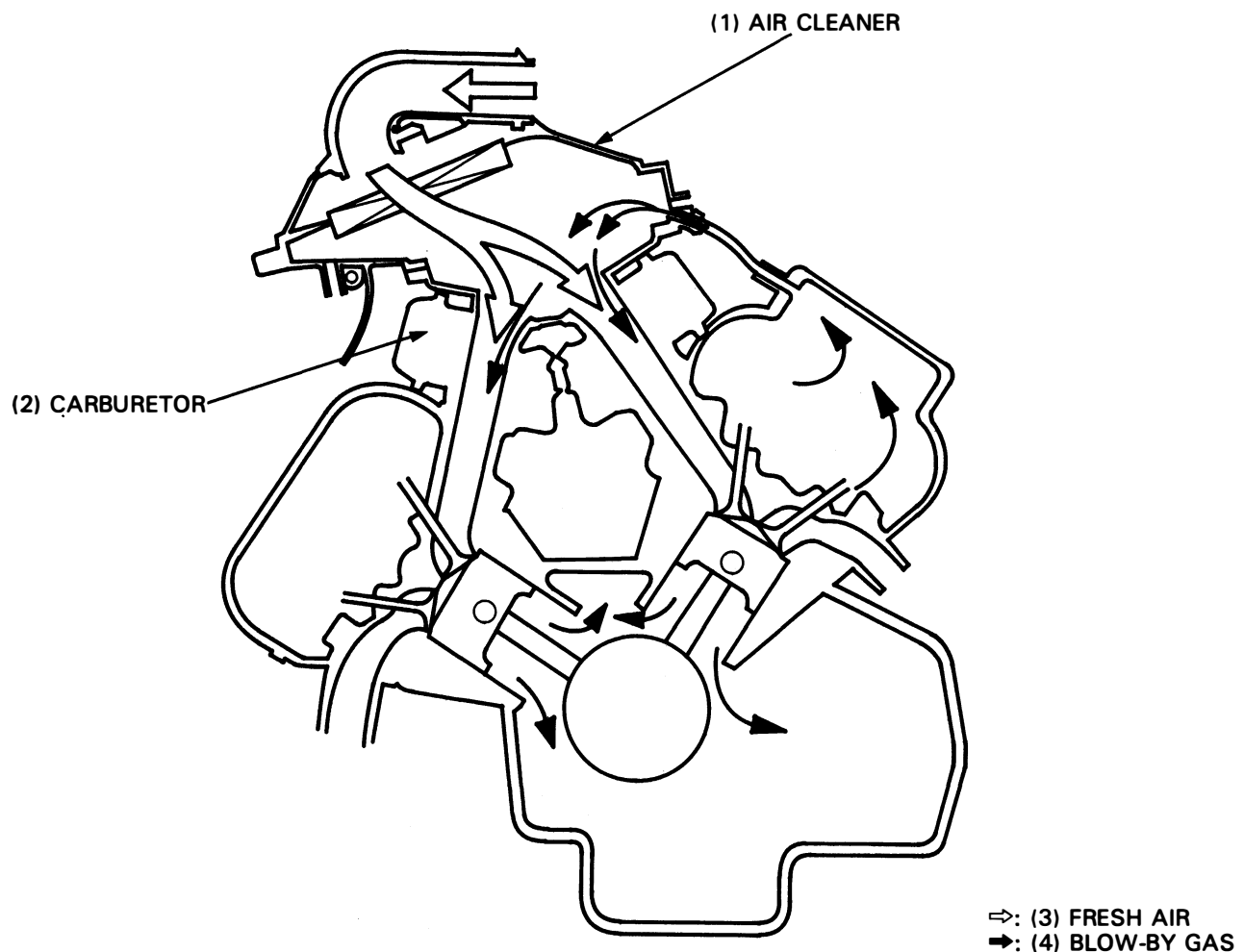

Exhaust Emission Control System (Pulse Secondary Air Injection System)

California type only

The exhaust emission control system consists of a pulse secondary air injection system which introduces filtered air into the exhaust gases in the exhaust port. Fresh air is drawn into the exhaust port whenever there is a negative pressure pulse in the exhaust system. This charge of fresh air promotes burning of the unburned exhaust gases and changes a considerable amount of hydrocarbons and carbon monoxide into relatively harmless carbon dioxide and water vapor.

This model has two pulse secondary air injection control valves with built-in check valves. The PAIR check valves prevent reverse air flow through the system. The pulse secondary air injection control valve reacts to high intake manifold vacuum and will cut off the supply of fresh air during engine deceleration, thereby preventing afterburn in the exhaust system.

No adjustments to the secondary air supply system should be made, although periodic inspection of the components is recommended.

(1) FRONT PULSE SECONDARY AIR INJECTION (PAIR) CONTROL VALVE

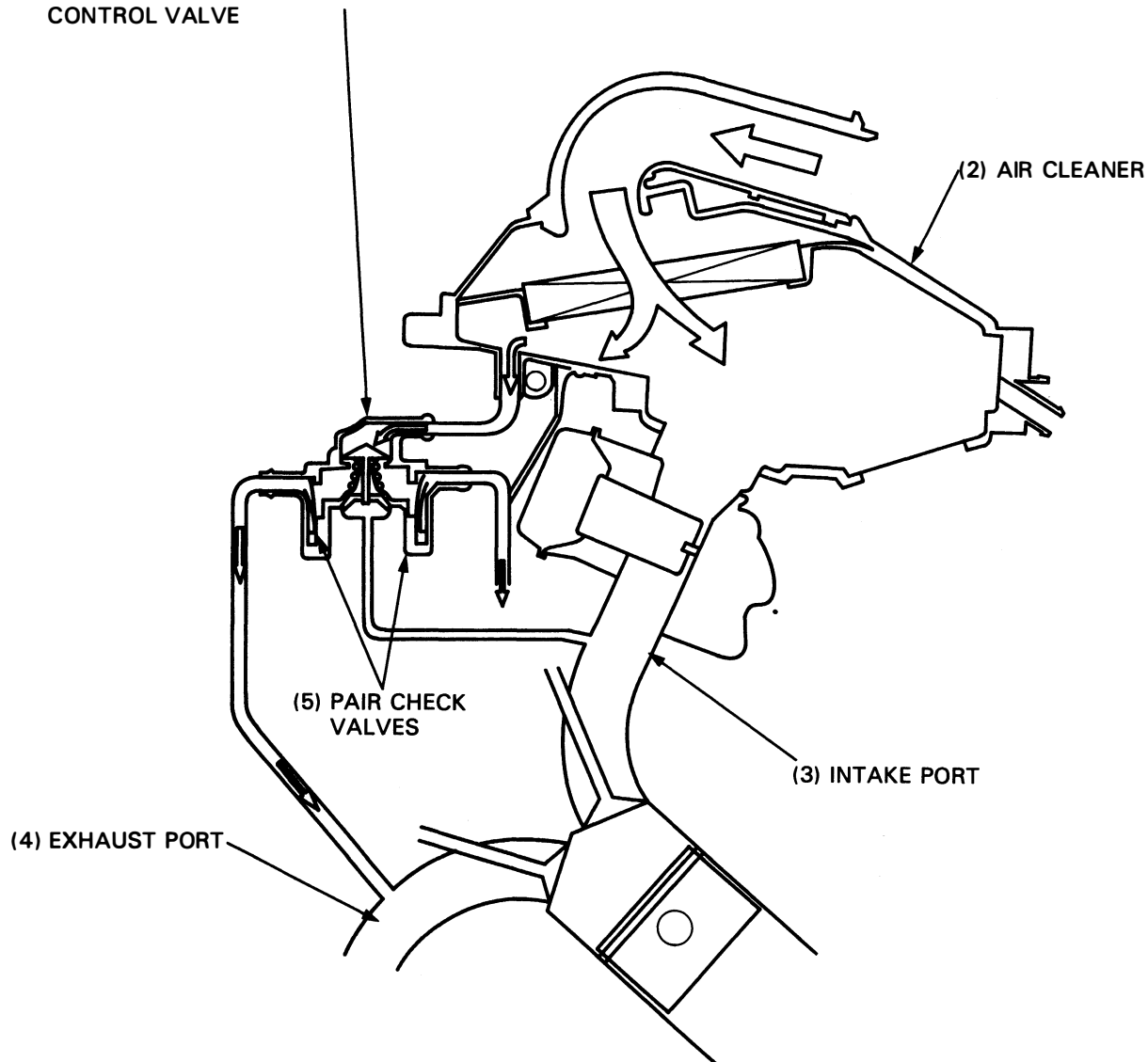

Evaporative Emission Control System (California Type Only)

This vehicle complies with the California Air Resources Board requirements for control of evaporative emissions.

Fuel vapor from the fuel tank and carburetor is routed into the evaporative emission canister where it is absorbed and stored while the engine is stopped. When the engine is running and the evaporative emission purge control diaphragm valve is open fuel vapor in the evaporative emission canister is drawn into the engine through the carburetor. At the same time, the evaporative emission carburetor air vent control valve is open and air is drawn into the carburetor through the valve.

(1) EVAPORATIVE EMISSION (EVAP) PURGE CONTROL VALVE

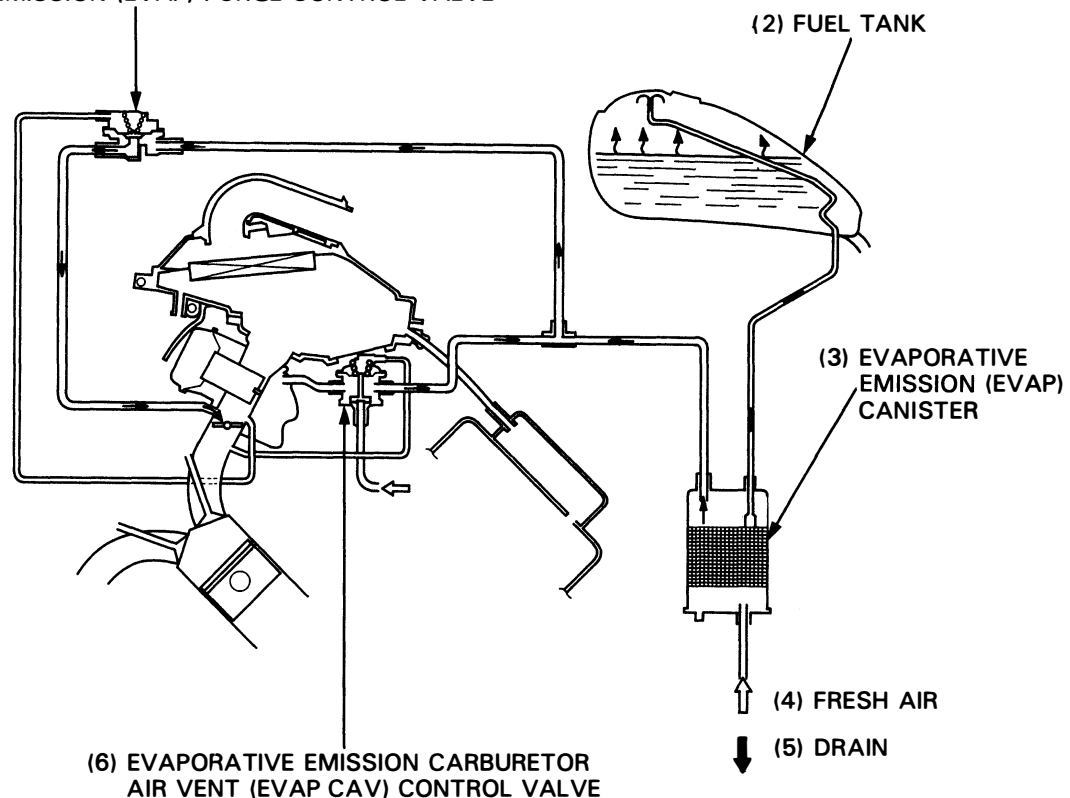

⇨: (7) FRESH AIR

➔: (8) FUEL VAPOR

Noise Emission Control System

TAMPERING WITH THE NOISE CONTROL SYSTEM IS PROHIBITED: Federal law prohibits the following acts or the causing thereof: (1) the removal or rendering inoperative by any person, other than for purposes of maintenance, repair or replacement, of any device or element of design incorporated into any new vehicle for purpose of noise control prior to its sale or delivery to the ultimate purchaser or while it is in use; or (2) the use of the vehicle after such device or element of design has been removed or rendered inoperative by any person.

Among those acts presumed to constitute tampering are the acts listed below:

1. Removal of, or puncturing the muffler, baffles, header pipes or any other component which conducts exhaust gases.
2. Removal of, or puncturing of any parts of the intake system.
3. Lack of proper maintenance.
4. Replacing any moving parts of the vehicle, or parts of the exhaust or intake system, with parts other than those specified by the manufacturer.

Emission Control Information labels (U.S.A. Only)

An Emission Information Label is located on the frame as shown. The right side cover must be removed to view it. It gives basic tune-up specifications.

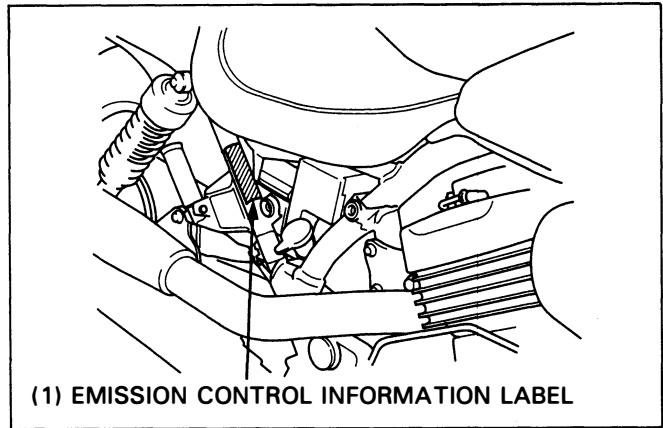

Vehicle Emission Control Information Update Label

After making a high altitude carburetor adjustment, attach an update label on the right down tube as shown.

After re-adjusting the carburetor back to standard settings for low altitude, remove the update label.

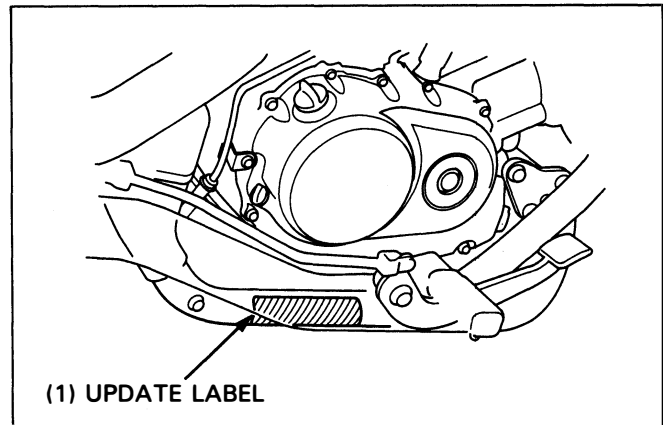

Vacuum Hose Routing Diagram Label (California Type Only)

The Vacuum Hose Routing Diagram Label is on the rear fender as shown.

The seat must be removed to view it.

Route the vacuum hoses as shown on this label.

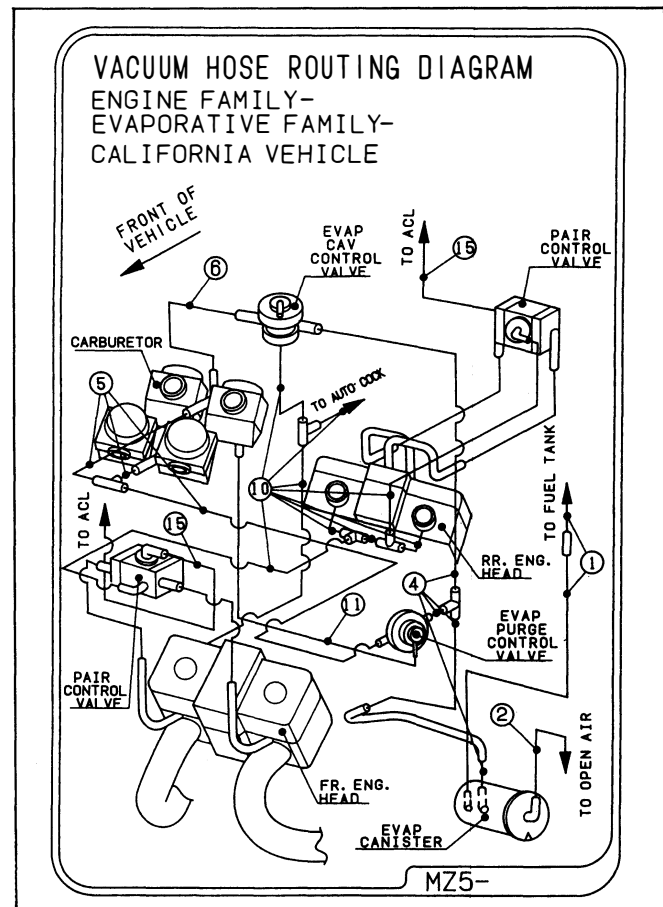
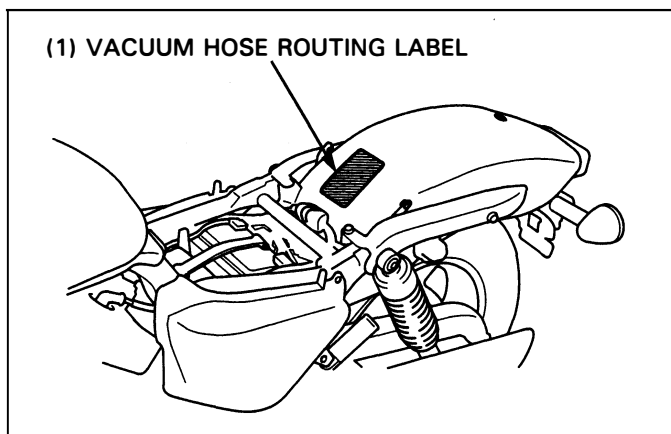

2. Frame/Body Panels/Exhaust System

Service Information	2-1	Front Side Cover Removal/Installation	2-3
Troubleshooting	2-1	Exhaust System Removal/Installation	2-4
Seat Removal/Installation	2-2	Rear Fender Removal/Installation	2-7
Fuel Tank Removal/Installation	2-2	Upper Fairing Removal/Installation (VF750CD)	2-8
Side Cover Removal/Installation	2-3		

Service Information

⚠ WARNING

- Gasoline is extremely flammable and is explosive under certain conditions. KEEP OUT OF REACH OF CHILDREN.
 - Serious burns may result if the exhaust system is not allowed to cool before components are removed or serviced.
-
- Work in a well ventilated area. Smoking or allowing flames or sparks in the working area or where gasoline is stored can cause a fire or explosion.
 - This section covers removal and installation of the frame body panels, fuel tank and exhaust system.
 - Always replace the exhaust pipe gaskets after removing the exhaust pipe from the engine.
 - When installing the exhaust pipe, install all the fasteners loosely. Next, tighten the exhaust pipe joint nuts first, then tighten the mounting fasteners. If you tighten the mounting fasteners first, the exhaust pipe may not seat properly.
 - Always inspect the exhaust system for leaks after installation.

Troubleshooting

Excessive Exhaust Noise

- Broken exhaust system
- Exhaust gas leak

Poor Performance

- Deformed exhaust system
- Exhaust gas leak
- Clogged muffler

Seat Removal/Installation

Remove the seat by removing the three mounting bolts.

During seat installation, align the seat hook with the frame hook and holes of the seat with the bosses on the side covers.

Install the three mounting bolts.

CAUTION

- Be careful not to pinch the wire harness between the seat and frame.

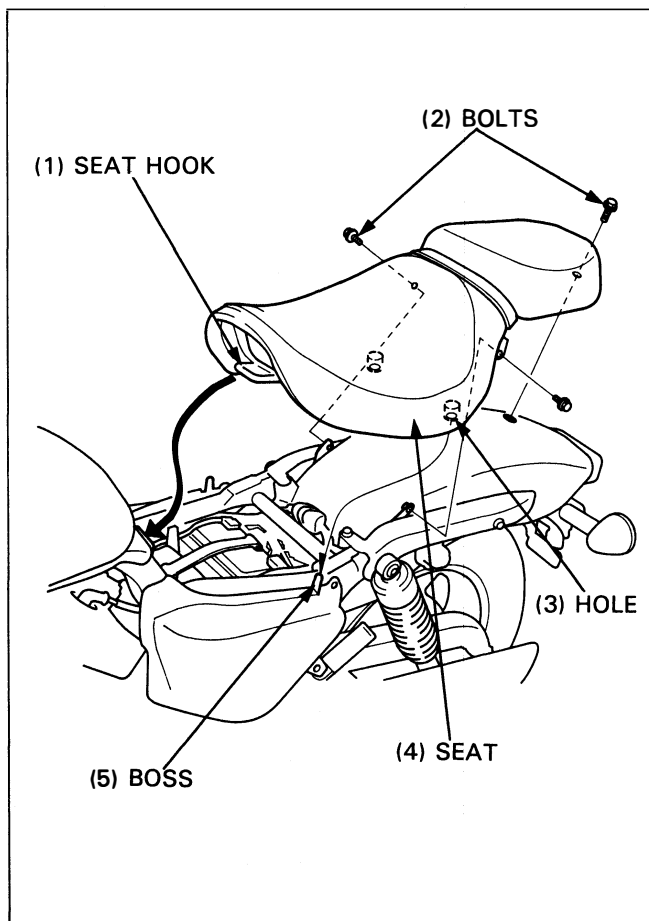

Fuel Tank Removal/Installation

⚠ WARNING

- Gasoline is extremely flammable and is explosive under certain conditions.

Remove the seat (above).

Turn the fuel valve OFF.
Disconnect the fuel tube.
Remove the mounting bolt and collar.
Disconnect the breather tube.

Remove the fuel tank.

Install the fuel tank in the reverse order of removal.
After installation, turn the fuel valve ON and check the fuel line for leakage.

Install the seat (above).

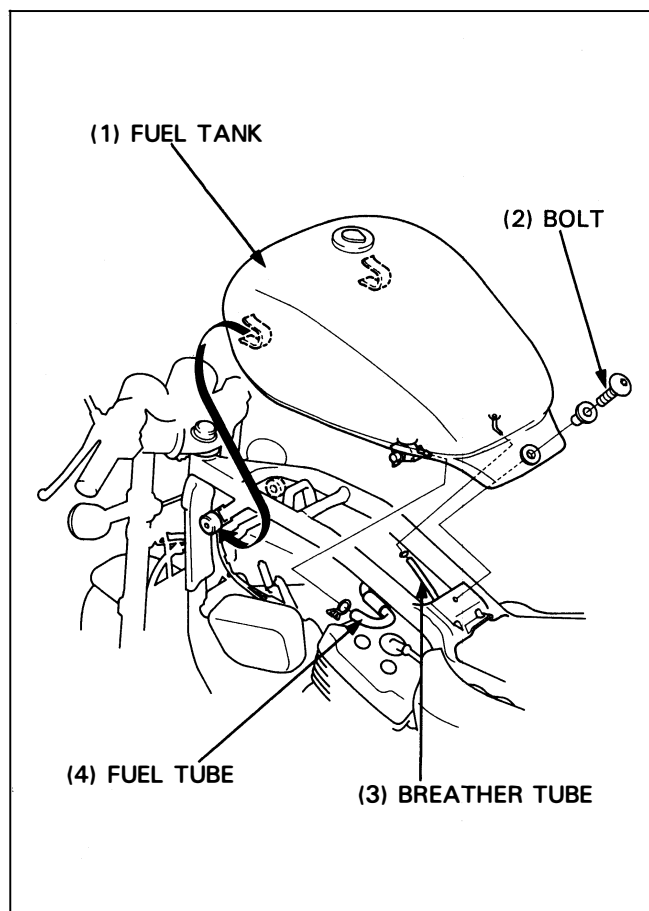

Side Cover Removal/Installation

Pull the cover bosses from the grommets.
Slide the cover boss down from the hole in the seat and remove the side cover.

NOTE

- Be careful not to damage the boss.

Install the side cover in the reverse order of removal.

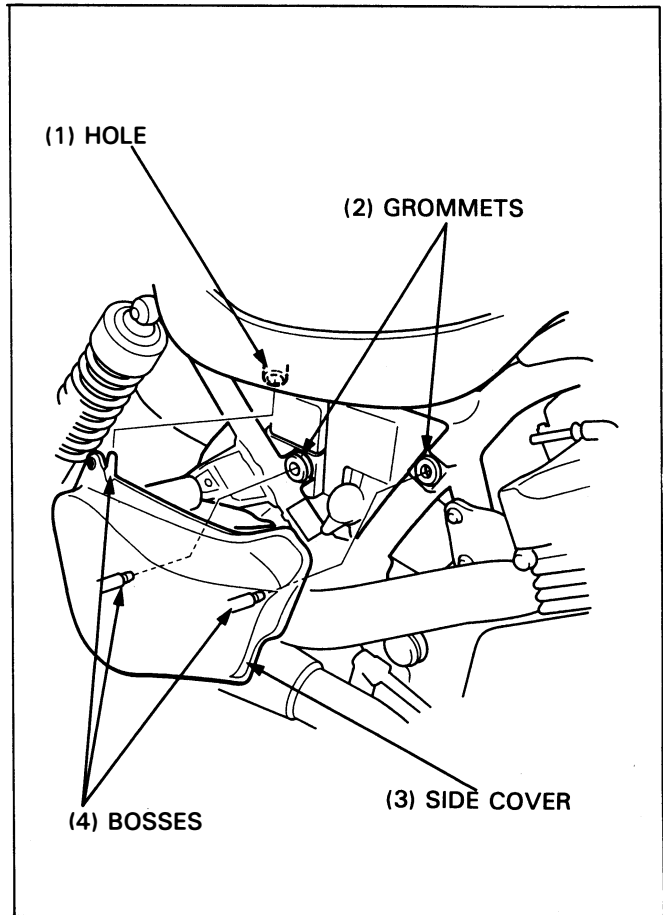

Front Side Cover Removal/Installation

Remove the front side cover mounting screw. Then remove the cover by sliding it forward.

Install the front side cover in the reverse order of removal.

NOTE

- At installation, align the tab of the front side cover with the groove of fuel tank mount bracket.

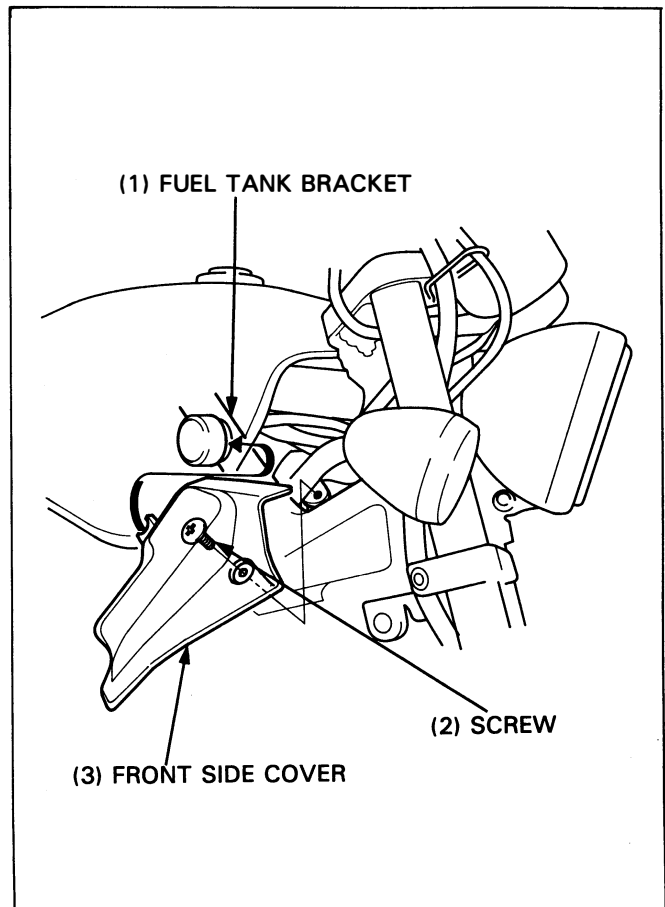

Exhaust System Removal/Installation

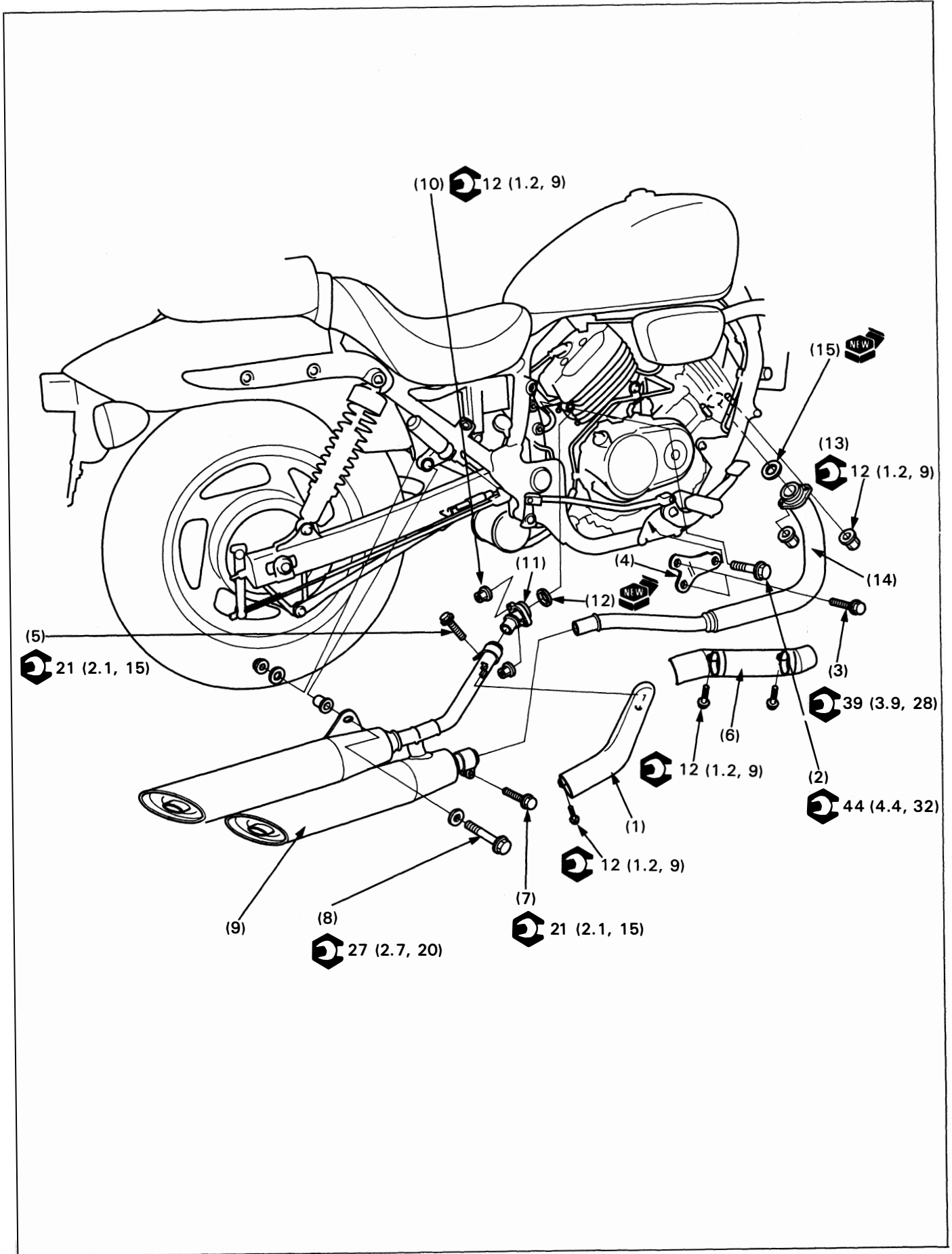

⚠ WARNING

- Do not service the exhaust system while it is hot.

NOTE

- When installing the exhaust pipe/muffler, always tighten the exhaust pipe joint nuts first, then tighten the mounting fasteners, see next page.

Procedure		Q'ty	Remarks
	Removal Order		Installation is in the reverse order of removal. Installation (page 2-6)
(1)	Rear exhaust pipe protector	1	
(2)	Rear cylinder head mount bolt	1	
(3)	Rear cylinder head mount bracket bolt	2	
(4)	Rear cylinder head mount bracket	1	
(5)	Rear exhaust pipe band bolt	1	Loosen the band bolt.
(6)	Front exhaust pipe protector	1	
(7)	Front exhaust pipe band bolt	1	Loosen the band bolt.
(8)	Muffler mounting bolt	1	
(9)	Muffler assembly	1	
(10)	Rear exhaust pipe joint nut	2	
(11)	Rear exhaust pipe	1	
(12)	Exhaust pipe gasket	1	
(13)	Front exhaust pipe joint nut	2	
(14)	Front exhaust pipe	1	
(15)	Exhaust pipe gasket	1	

Rear Exhaust Pipe Protector Installation

Install the rubber cap to the rear exhaust pipe hook.
Align the hook of the rear exhaust pipe with groove of the rear exhaust pipe protector.

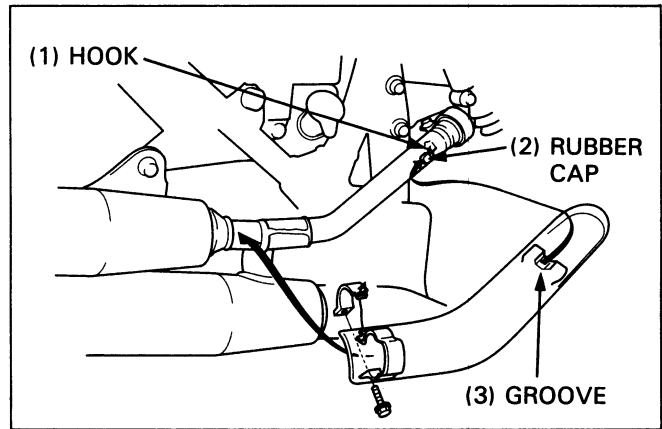

Adjust the clearance by moving the protector.

Standard: 2–5 mm (0.08–0.19 in)

Tighten the exhaust pipe protector bolt.

Torque: 12 N·m (1.2 kg·m, 9 ft·lb)

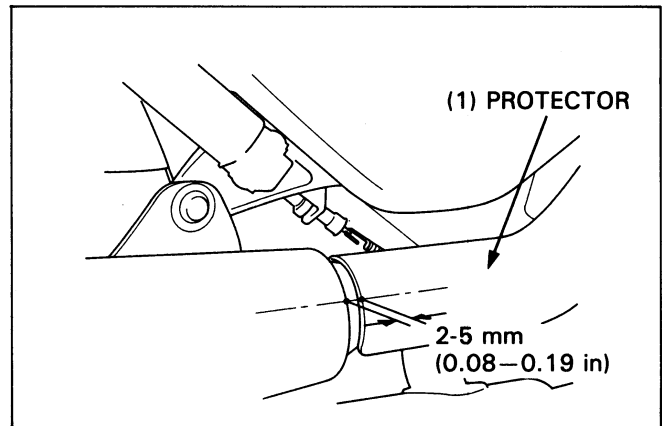

Exhaust Pipe/muffler Mounting Fasteners Tightening

When tighten the exhaust pipe/muffler mounting fasteners, while push the exhaust pipe to inside.

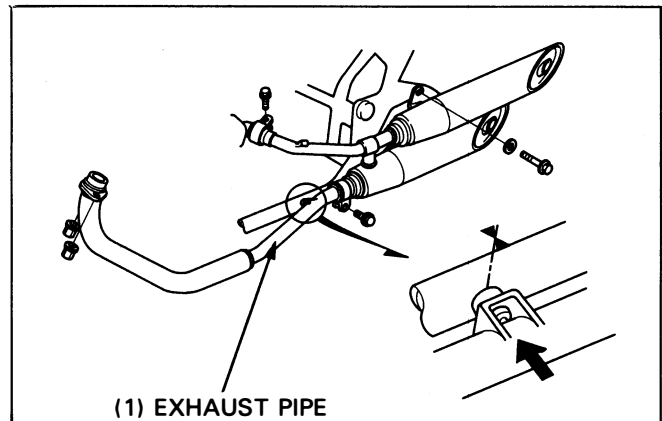

Rear Fender Removal/Installation

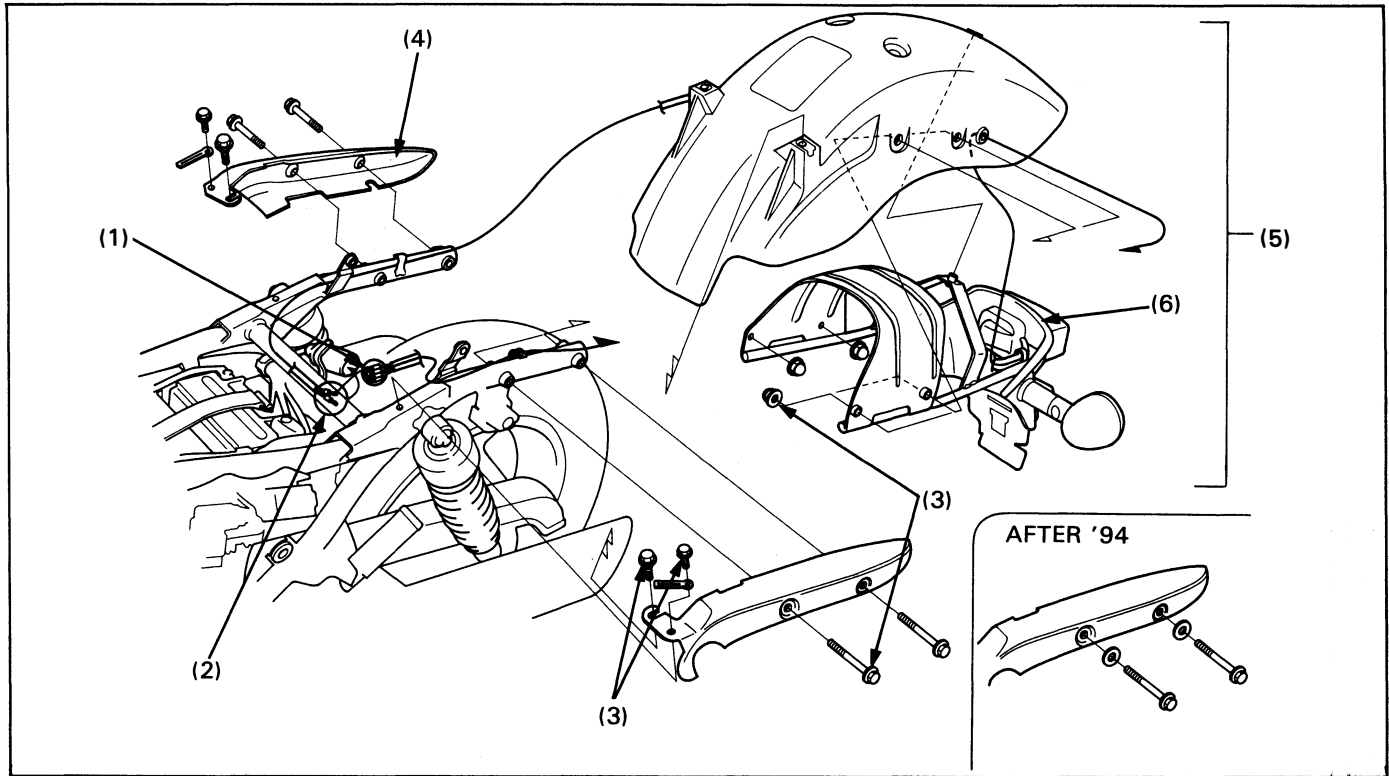

NOTE

- Route the wire harness properly (page 1-20).

Requisite Service

- Seat removal/installation (page 2-2).
- Side covers removal/installation (page 2-3)

Procedure		Q'ty	Remarks
Removal Order			Installation is in the reverse order of removal.
(1)	Rear turn signal light connector	4	Disconnect the connector.
(2)	Brake/taillight connector	3	Disconnect the connector.
(3)	Rear fender mounting bolt/nut	8/4	
(4)	Grab rail	2	
(5)	Rear fender assembly	1	
(6)	Sub frame	1	

Upper Fairing Removal/Installation (VF750CD)

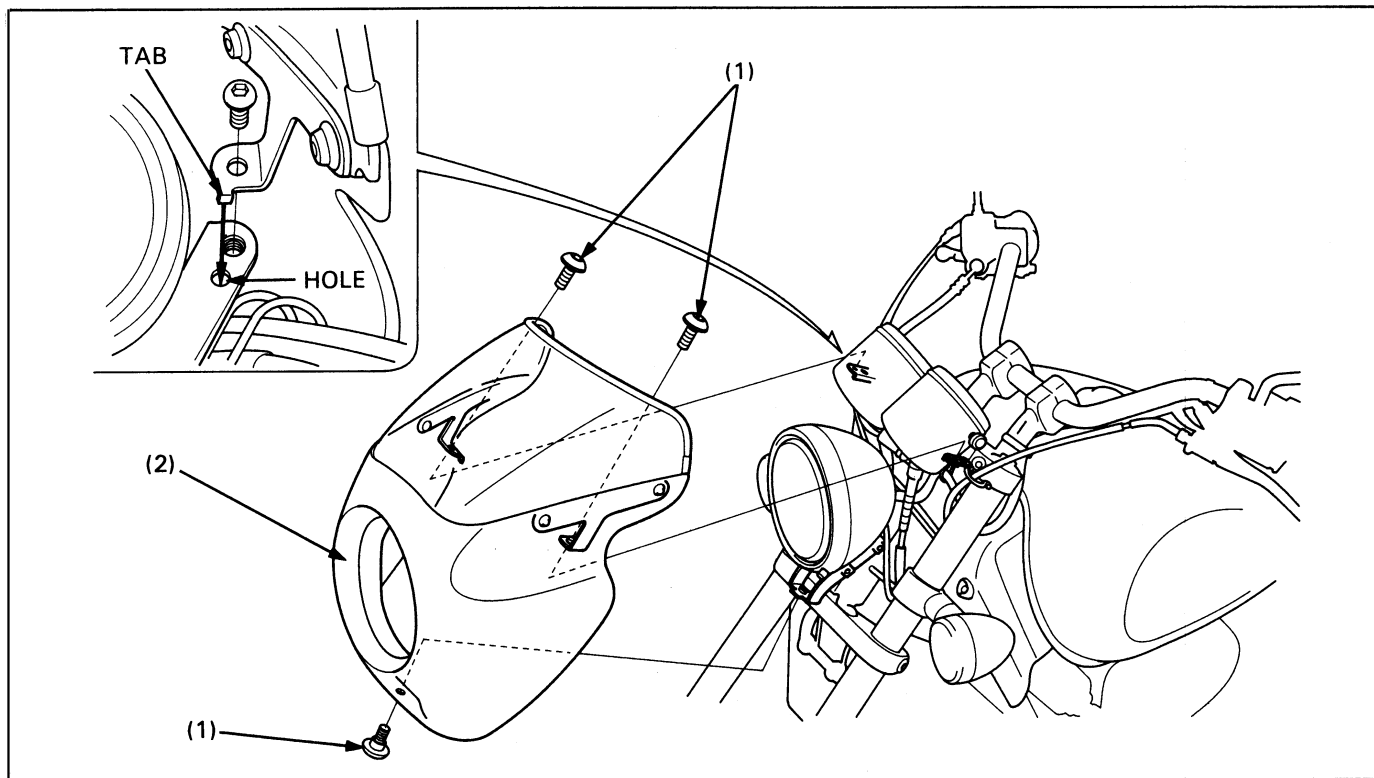

CAUTION

- Do not scratch and damage the windscreen.

Procedure		Q'ty	Remarks
Removal Order			Installation is in the reverse order of removal.
(1)	Upper fairing mounting bolt	3	
(2)	Upper fairing	1	At installation, align the tab of the upper fairing stay with the hole of the cable guige.

Windscreen Replacement

Remove the screws, plastic washers and rubber washers.
Remove the windscreen and upper fairing stays.

Installation is in the reverse order of removal.

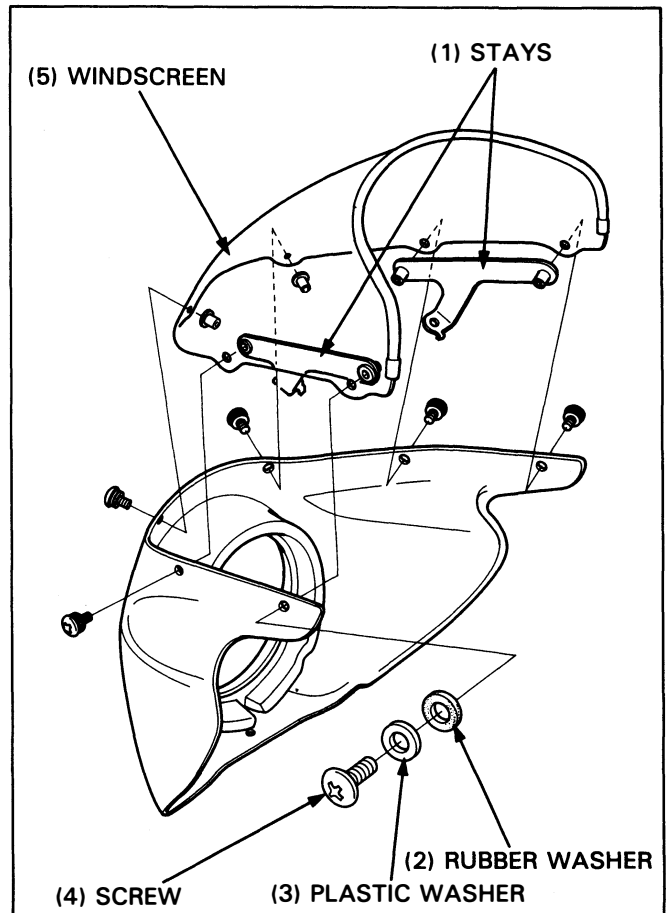

MEMO

3. Maintenance

Service Information	3-1	Valve Clearance	3-5
Service Access Guide	3-2	Drive Chain	3-8
Maintenance Schedule	3-4	Headlight Aim	3-10
Air Cleaner	3-5		

Service Information

- Refer to Common Service Manual for items not included in this manual.
- Refer to Specifications (Section 1) for maintenance data.

Service Access Guide

- The following shows the locations of the parts that must be removed for the maintenance items listed below. Refer to the Common Service Manual for items not included in this manual.
- Refer to section 2 (Frame/Body Panels/Exhaust System), for the parts that must be removed for service.
For example: Air Cleaner (Contamination, clogging, replacement): Parts
 - Rear Fairing—The part required to be removed for service.

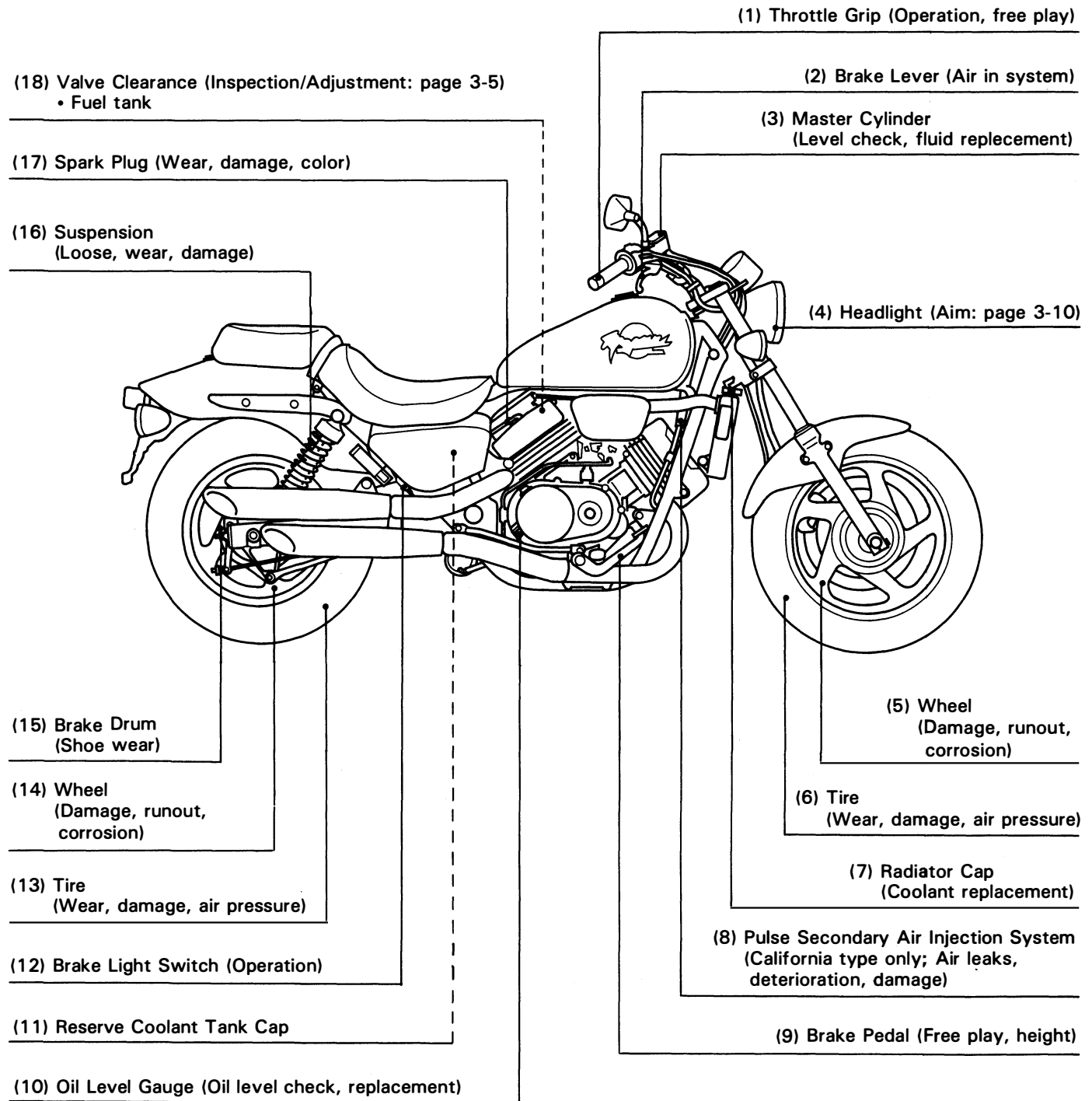

(13) Air Cleaner
(Contamination, clogging, replacement; page 3-5)
• Fuel tank

(1) Synchronization Adjusting Screw
(Carburetor synchronizatron; page 5-14)
• Middle cover

(12) Clutch Lever (Free play)

(11) Steering Head Bearing (Damage)

(10) Suspension
(Loose, wear, damage)

(2) Fuel Line (Damage, leakage)

(9) Caliper (Pad wear)

(8) Brake Hose
(Leakage, deterioration,
damage)

(7) Oil Filter (Replacement)

(6) Carburetor Choke (Operation)

(3) Drive chain
(Free play, lubrication,
replacement; page 3-8)

(4) Side stand (Operation)

(5) Throttle Stop Screw

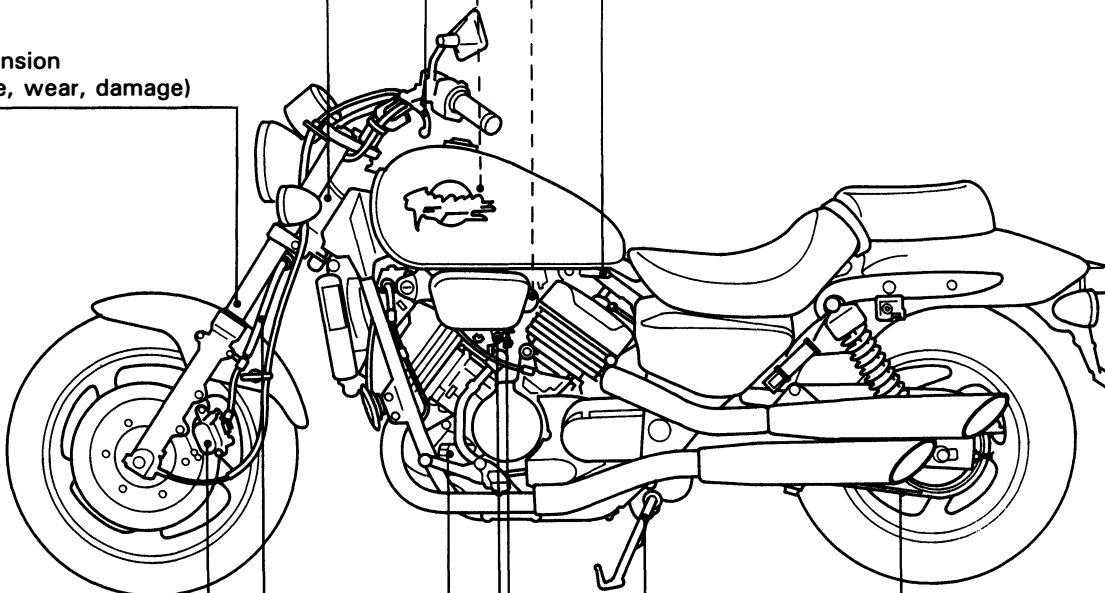

Maintenance Schedule

Perform the PRE-RIDE INSPECTION in the Owner's Manual at each scheduled maintenance period.

I: Inspect and clean, Adjust, Lubricate, or Replace if necessary.

R: Replace, C: Clean, L: Lubricate, A: Adjust

The following items require some mechanical knowledge. Certain items (particularly those marked * and **) may require more technical information and tools. Consult their authorized Honda dealer.

Items	Frequency	Note	Odometer Reading (Note 1)								Refer To Page	
			x 1,000 mi	0.6	4	8	12	16	20	24		
			x 100 km	10	64	128	192	256	320	384		
EMISSION RELATED ITEMS	*	Fuel Line				I		I		I	Note 5	
	*	Throttle Operation				I		I		I	Note 5	
	*	Carburetor Choke				I		I		I	Note 5	
	*	Air Cleaner	Note 2				R			R	3-5	
		Spark Plug			I	R	I	R	I	R	Note 5	
	*	Valve Clearance						I			3-5	
		Engine Oil			R		R		R		Note 5	
		Engine Oil Filter			R		R		R		Note 5	
	*	Carburetor Synchronization				I		I		I	5-14	
	*	Carburetor Idle Speed			I	I	I	I	I	I	Note 5	
		Radiator Coolant	Note 3			I		I		R	Note 5	
	*	Cooling System				I		I		I	Note 5	
	*	Secondary Air Supply System	Note 4			I		I		I	Note 5	
	*	Evaporative Emission Control System	Note 4				I			I	Note 5	
NON-EMISSION RELATED ITEMS		Drive Chain		Every 600 mi (1,000 km) I, L								Note 5
		Brake Fluid	Note 3		I	I	R	I	I	R	Note 5	
		Brake Shoe/Pad Wear			I	I	I	I	I	I	Note 5	
		Brake System		I		I		I		I	Note 5	
	*	Brake Light Switch				I		I		I	Note 5	
	*	Headlight Aim				I		I		I	Note 5	
		Clutch System		I	I	I	I	I	I	I	Note 5	
		Side Stand				I		I		I	Note 5	
	*	Suspension				I		I		I	Note 5	
	*	Nuts, Bolts, Fasteners		I		I		I		I	1-12	
	**	Wheels/Tires				I		I		I	Note 5	
	**	Steering Head Bearings		I		I		I		I	Note 5	

* Should be serviced by an authorized Honda dealer, unless the owner has the proper tools and service data and is mechanically qualified.

** In the interest of safety, we recommended these items be serviced only by an authorized Honda dealer.

- Notes:
- At higher odometer readings, repeat at the frequency interval established here.
 - Service more frequently when riding in unusually wet or dusty areas.
 - Replace every 2 years, or at indicated odometer interval, whichever comes first. Replace requires mechanical skill.
 - California type only.
 - Refer to Common Service Manual.

Air Cleaner

Remove the fuel tank (page 2-2).
 Remove the front side cover (page 2-3).
 Remove the two screws and air duct stopper.
 Remove the air duct by sliding it backward.

Remove the nine screws and air cleaner housing cover/air cleaner.
 Remove the air cleaner from the air cleaner housing cover.

Discard the air cleaner in accordance with the maintenance schedule.
 Also, replace the element any time it is excessively dirty or damaged.

Install the removed parts in the reverse order of removal.

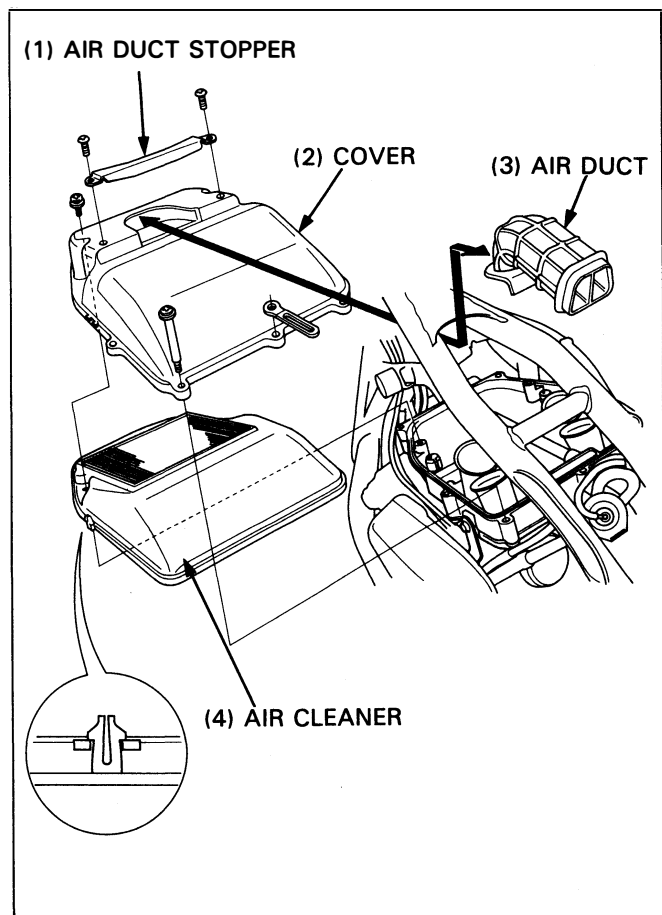

Valve Clearance

Inspection

NOTE

- Inspect and adjust the valve clearance while the engine is cold (Below 35°C/95°F).

Remove the following:

- timing hole cap
- seat (page 2-2)
- fuel tank (page 2-2)
- rear cylinder head cover (page 8-2)

Remove the lower radiator hose guide.
 Remove the lower radiator mounting bolts, loosen the upper mounting bolt and swing the radiator forward, then secure it out of the way.

CAUTION

- Be careful not to damage the radiator fins.

Remove the front cylinder head cover (page 8-2).

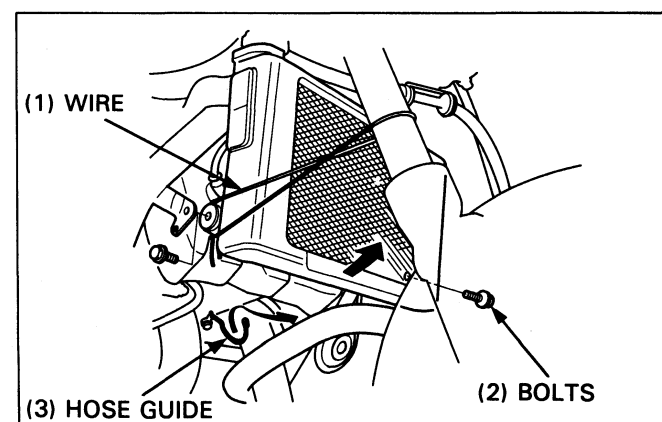
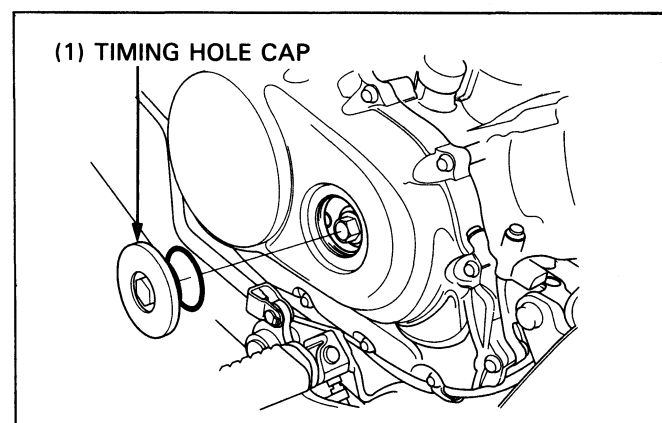

Maintenance

Turn the crankshaft clockwise and align its "T1" mark with the index mark on the right crankcase cover.

Make sure that No. 1 piston is at TDC (Top Dead Center) on the compression stroke.
If it is not on the compression stroke, turn the crankshaft one full turn (360°) clockwise.

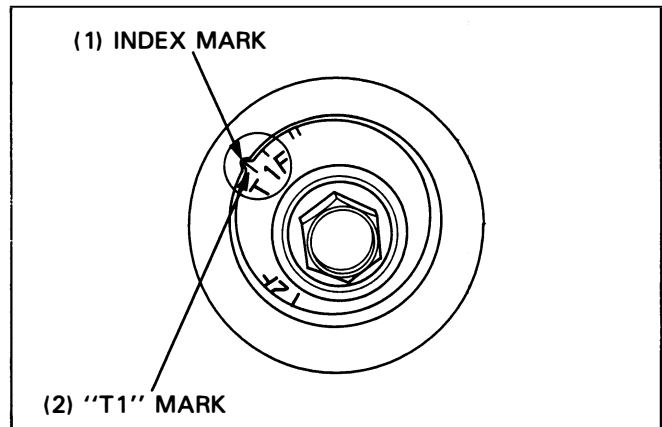

Insert the feeler gauge between the valve lifter and the cam lobe.
Check the valve clearances for the No. 1 cylinder intake and exhaust valves using a feeler gauge.

Valve clearance:

IN: 0.16 ± 0.02 mm (0.006 ± 0.001 in)

EX: 0.25 ± 0.02 mm (0.010 ± 0.001 in)

NOTE

- Record the clearance for each valve for reference in shim selection if adjustment is required.

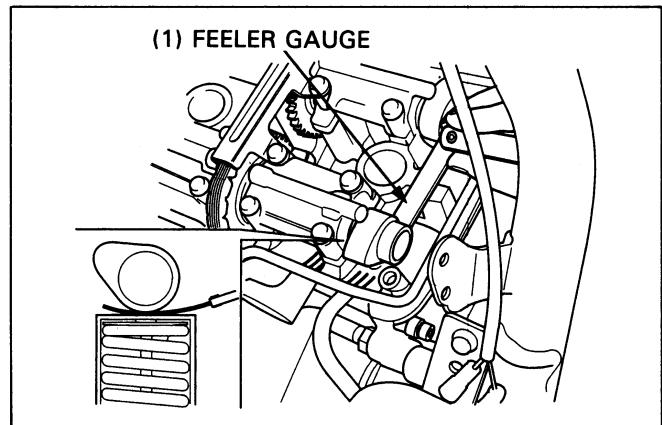

Turn the crankshaft clockwise 1/4-turn (90°) and align its "T2" mark with the index mark on the right crankcase cover.

Check the valve clearances for the No. 4 cylinder.

Turn the crankshaft clockwise 3/4-turn (270°) and align its "T1" mark with the index mark on the right crankcase cover.

Check the valve clearances for the No. 3 cylinder.

Turn the crankshaft clockwise 1/4-turn (90°) and align its "T2" mark with the index mark on the right crankcase cover.

Check the valve clearances for the No. 2 cylinder.

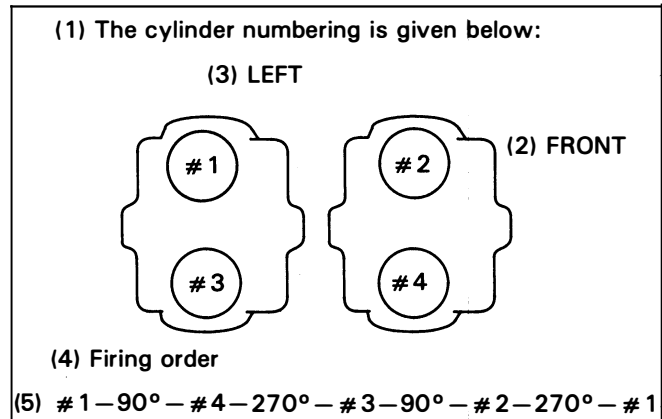

Adjustment

Remove the camshafts (page 8-2).
Remove the valve lifters and shims.

NOTE

- Shims may stick to the inside of the valve lifter. Do not allow the shims to fall into the crankcase.
- Mark all lifters and shims to ensure correct reassembly.
- The valve lifter can be easily removed with a valve lapping tool or magnet.
- The shims can be easily removed with tweezers or a magnet.

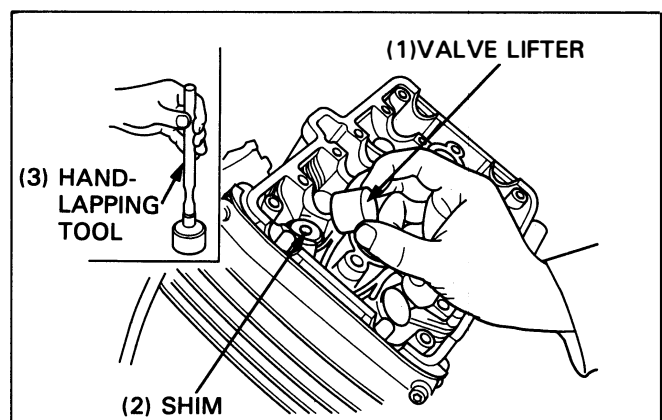

Clean the valve shim contact area in the valve lifter with compressed air.

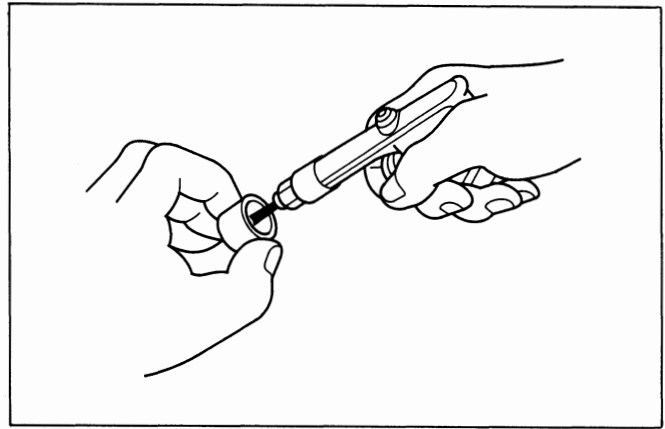

Measure the shim thickness and record it.

NOTE

- Sixty-five different shim thickness are available: from the thinnest (1.200 mm) to the thickest (2.800 mm) in intervals of 0.025 mm.

Calculate the new shim thickness using the equation below.

$$A = B - C + D$$

- A: New shim thickness**
B: Recorded valve clearance
C: Specified valve clearance
D: Old shim thickness

Example:

Recorded valve clearance: 0.16 mm
Old shim thickness: 1.725 mm
Specified valve clearance: 0.20 mm

$$A = 0.16 - 0.20 + 1.725$$

$$A = 1.685$$

NOTE

- Make sure of the correct shim thickness by measuring the shim with micrometer.
- Replace the valve seat if a carbon deposit results in a calculated dimension of over 2.800 mm.

Install the newly selected shim on the valve retainer.
 Apply molybdenum disulfide oil to the valve lifter.
 Install the valve lifter in the valve lifter holes.

NOTE

- Install the unchange shims and valve lifters in their original locations.

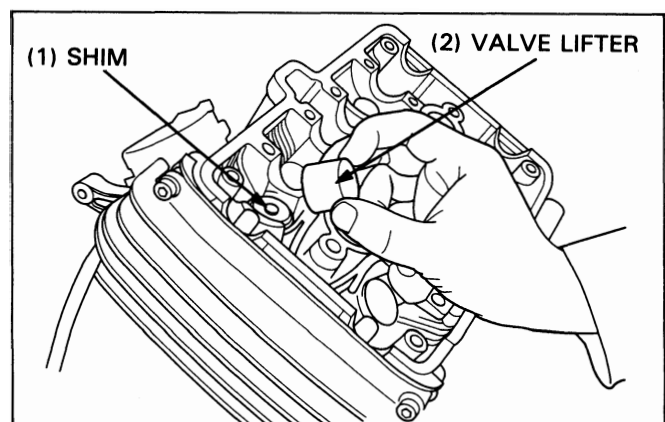
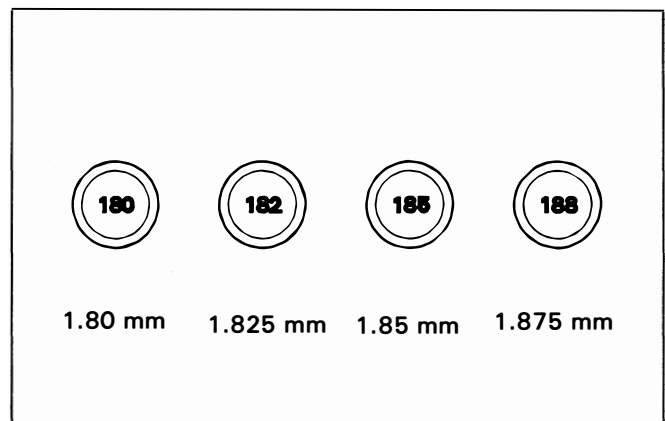
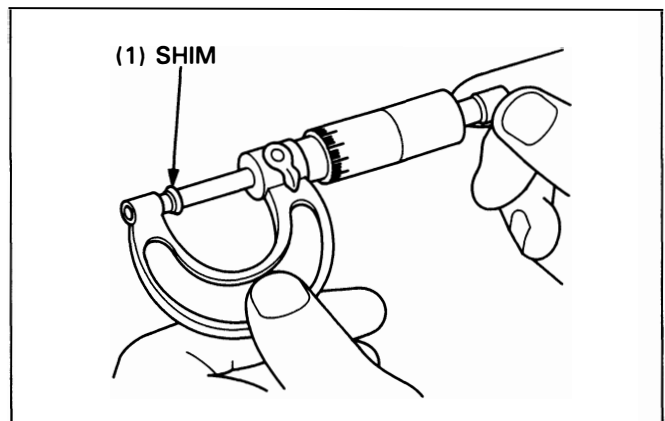

Maintenance

Install the camshaft and camshaft holders (page 8-8).
Rotate the camshafts by rotating the crankshaft clockwise several times.
Recheck the valve clearance.

Apply Honda Bond A to the cylinder head cover grooves as shown.
Install the cover gasket with the "IN" mark facing the intake side.

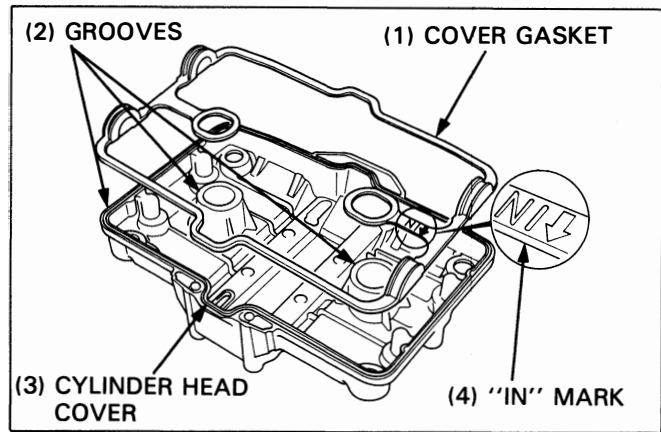

Install the cover bolt washer with the "UP" mark facing up.
Tighten the cover bolts.

Torque: 10 N·m (1.0 kg-m, 7 ft-lb)

Install the removed parts in the reverse order of removal.

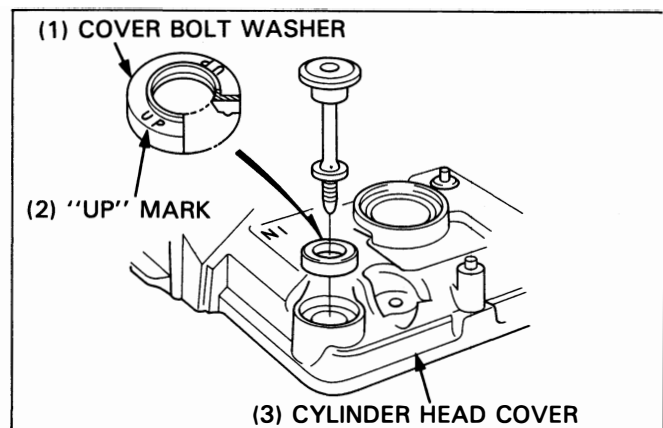

Drive Chain

Replacement

The MAGNA VF750C uses a drive chain with a staked master link.
Loosen the drive chain.

Assemble the special tool.

S. TOOL

Drive chain cutter

**07HMH-MR10102 or
07HMH-MR1010B
(U.S.A. only)**

NOTE

- When using the special tool, follow the manufacture's operating instructions.

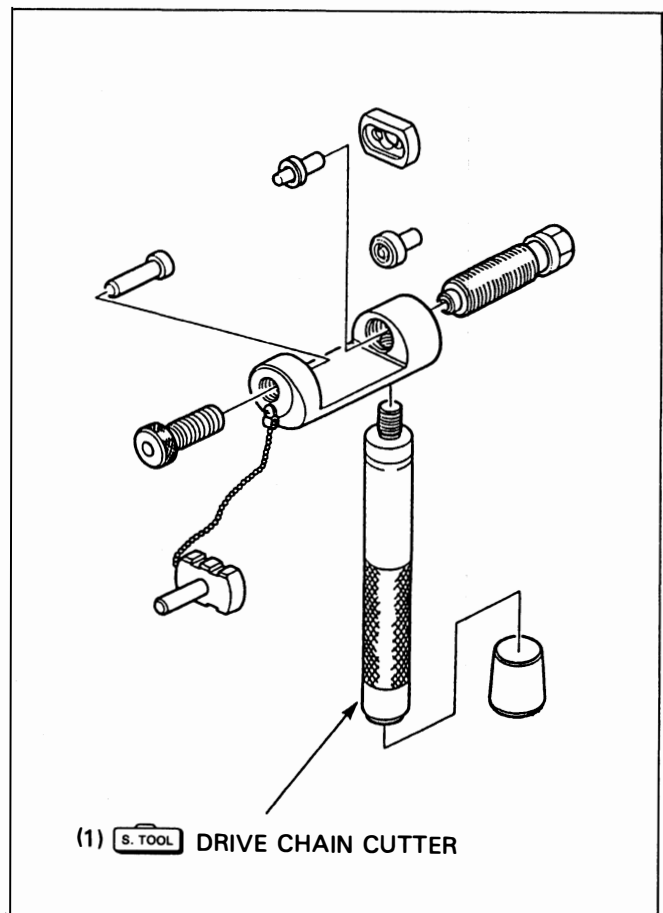

Locate the crimped pin ends of the master link from the outside of the chain and remove the link with the drive chain cutter.

S. TOOL

Drive chain cutter

07HMH—MR10102 or
07HMH—MR1010B
(U.S.A. only)

NOTE

- When using the special tool, follow the manufacture's operating instructions.

Remove the drive chain.

Remove the excess drive chain links from the new drive chain with the drive chain cutter.

NOTE

- Include the master link when you count the drive chain links.

Standard link: 118 link

Replacement chain: RK 50 MFOZ1
: DID 50 V4

S. TOOL

Drive chain cutter

07HMH—MR10102 or
07HMH—MR1010B
(U.S.A. only)

Link plate holder

07NMH—MW00110
or 07PMH—MZ20110

CAUTION

- Never reuse the old drive chain, master link, master link plate and O-rings.

Install the new drive chain. Assemble the new master link, O-rings and plate.

CAUTION

- Insert the master link from the inside of the drive chain and install the plate with the identification mark facing the outside.

Assemble and set the drive chain cutter.

Make sure that the master link pins are installed properly. Measuring the master link pin length projected from the plate.

Standard length: 1.2—1.4 mm (0.05—0.06 in)

Stake the master link pins.

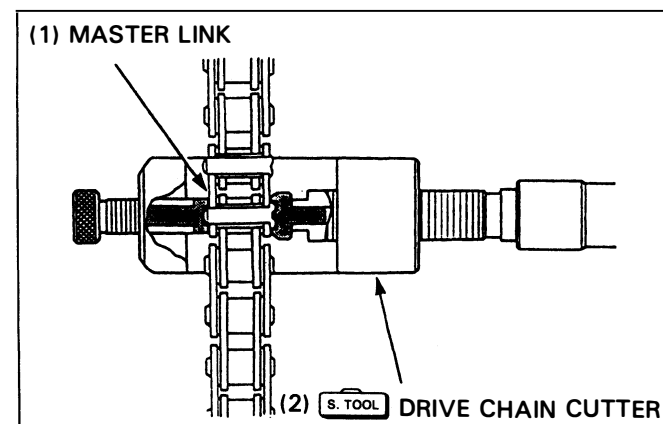
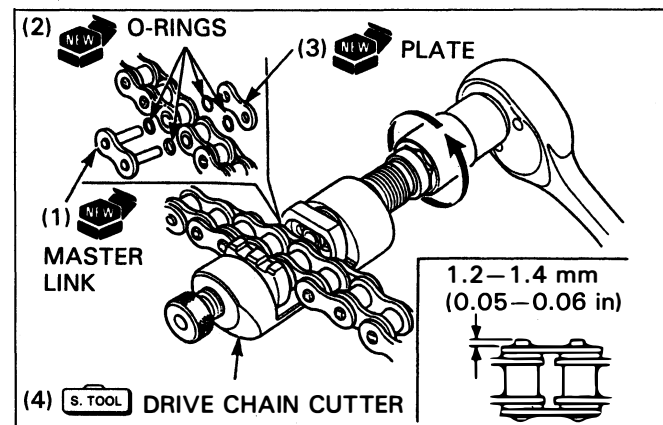
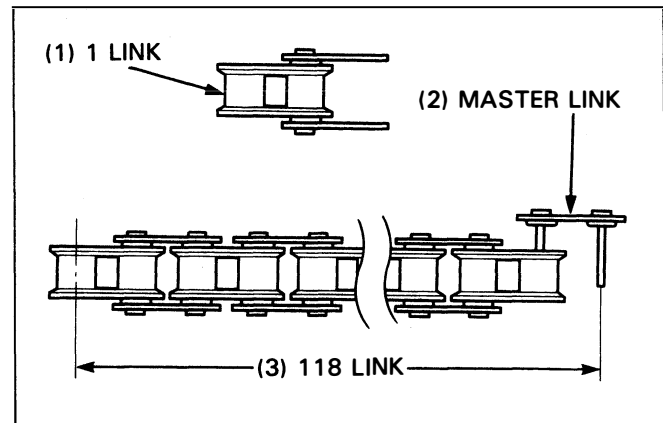
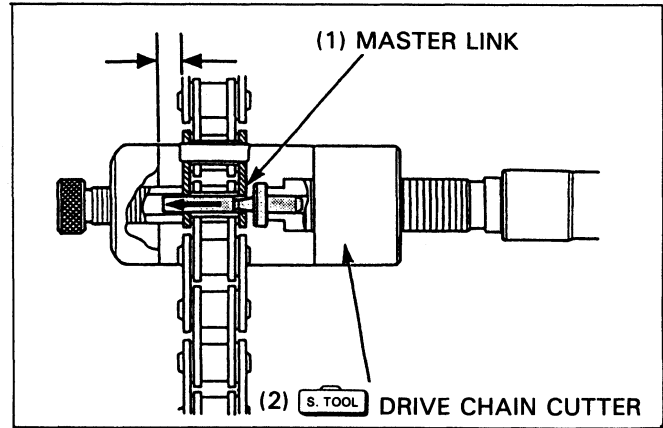

Maintenance

Make sure that the pins are staked properly by measuring the diameter of the staked area using a slide calipers.

Diameter of the staked area:

DID: 5.50—5.80 mm (0.217—0.228 in)

RK: 5.55—5.85 mm (0.210—0.230 in)

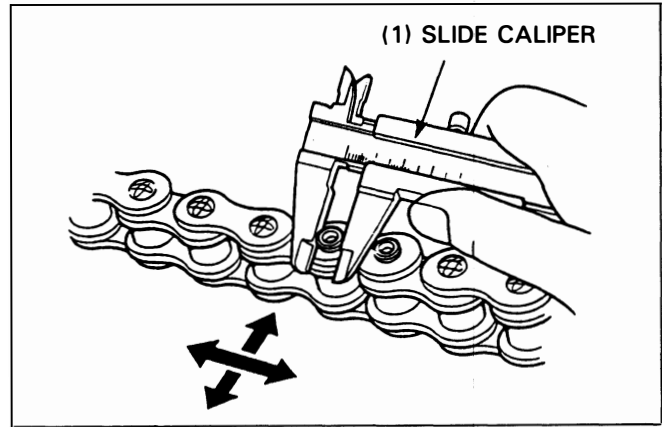

After staking, check the staked area of the master link for cracks. In there is any cracking, replace the master link, O-rings and plate.

CAUTION

- Drive chain with clip-type master link must not be used.

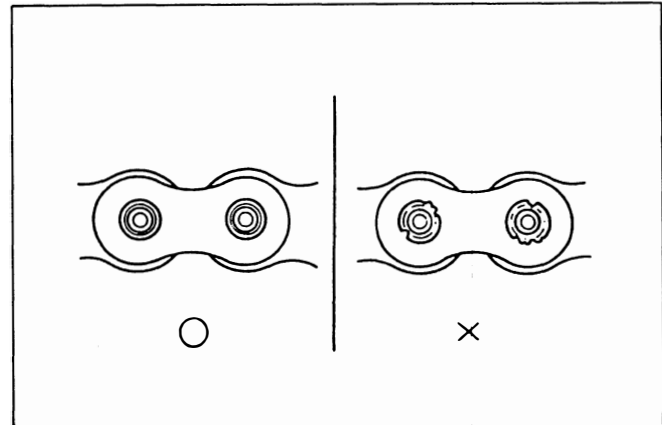

Headlight Aim

⚠ WARNING

- An improperly adjusted headlight may blind oncoming drivers, or it may fail to light the road for a safe distance.

VF750CD:

Adjust the headlight aim horizontally and vertically, turning the adjusting screws as shown.

VF750C:

Refer to section 2 of the common Service Manual.

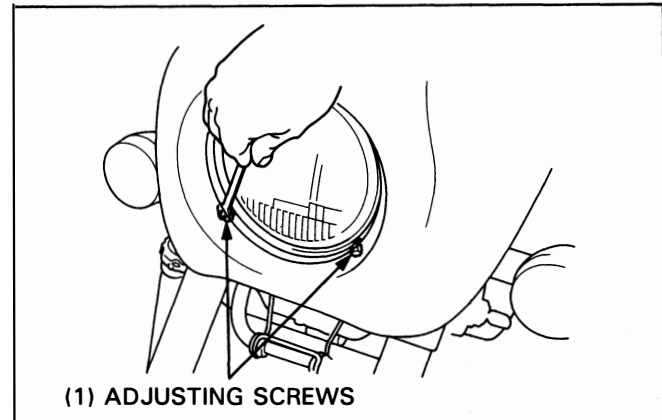

4. Lubrication System

Service Information	4-1	Oil Pump Removal/Installation	4-3
Troubleshooting	4-1	Oil Pump Disassembly/Assembly	4-4
Lubrication System Diagram	4-2		

Service Information

4

⚠ WARNING

- If the engine must be running to do some work, make sure the area is well ventilated. Never run the engine in an enclosed area. The exhaust contains poisonous carbon monoxide gas that can cause loss of consciousness and may lead to death. Run the engine in an open area or with an exhaust evacuation system in an enclosed area.
- Used engine oil may cause skin cancer if repeatedly left in contact with the skin for prolonged periods. Although this is unlikely unless you handle used oil on a daily basis, it is still advisable to thoroughly wash your hands with soap and water as soon as possible after handling used oil. KEEP OUT OF REACH OF CHILDREN.

- The oil pump can be serviced with the engine installed in the frame.
- For oil pressure check, refer to section 4 of the Common Service Manual; for the switch location, see page 18-2 of this manual
- The service procedures in this section must be performed with the engine oil drained.
- When removing and installing the oil pump use care not to allow dust or dirt to enter the engine.
- If any portion of the oil pump is worn beyond the specified service limits, replace the oil pump as an assembly.
- After the oil pump has been installed check that there are no oil leaks and that oil pressure is correct.

Troubleshooting

Oil Level Low

- Oil consumption
- External oil leak
- Worn piston ring or incorrect piston ring installation
- Worn valve guide or seal

Low Or No Oil Pressure

- Clogged oil orifice
- Incorrect oil being used

No Oil Pressure

- Oil level too low
- Oil pump drive chain or sprocket broken
- Oil pump damaged (rotor shaft)
- Internal oil leaks

Low Oil Pressure

- Clogged oil strainer screen
- Oil pump worn or damaged
- Internal oil leak
- Pressure relief valve stuck open
- Incorrect oil being used
- Low oil level

High Oil Pressure

- Plugged oil filter, gallery, or metering orifice
- Pressure relief valve stuck closed
- Incorrect oil being used

Lubrication System Diagram

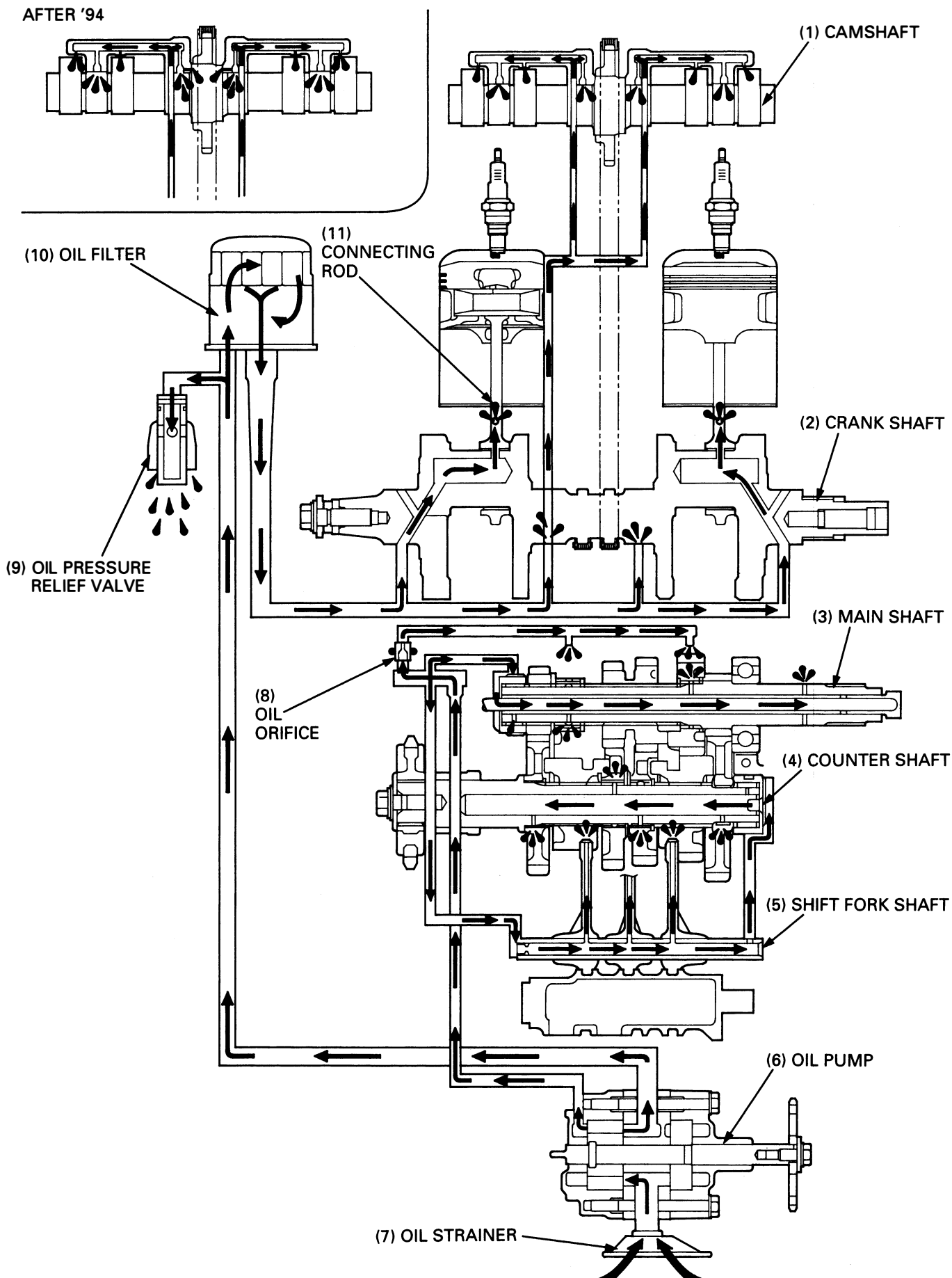

Oil Pump Removal/Installation

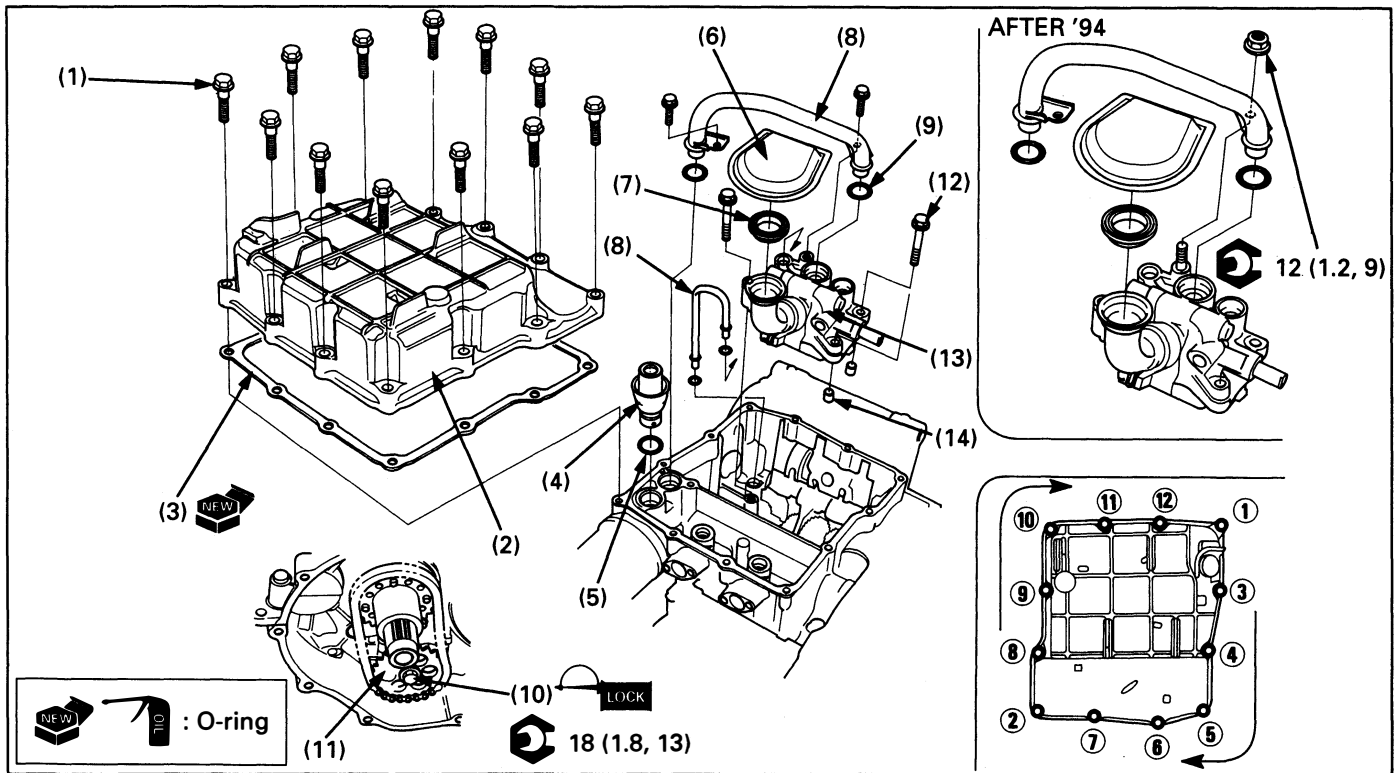

NOTE

- Use care to keep dust or dirt out of the engine.
- After installation, check that there are no oil leaks.

Requisite Service

- Engine oil draining/refilling
- Clutch removal/installation (page 9-4, 6)
- Exhaust system removal/installation (page 2-4)
- Water pump removal/installation (page 6-7)

Procedure	Q'ty	Remarks
Removal Order		Installation is in the reverse order of removal. At installation, tighten the bolts as shown.
(1) Oil pan bolt	12	
(2) Oil pan	1	
(3) Gasket	1	
(4) Pressure relief valve	1	
(5) O-ring	1	
(6) Oil strainer	1	
(7) O-ring	1	
(8) Oil pipe	2	
(9) O-ring	4	
(10) Oil pump driven sprocket bolt	1	Apply a locking agent to the threads.
(11) Oil pump driven sprocket	1	
(12) Oil pump mounting bolt	3	
(13) Oil pump assembly	1	
(14) Dowel pin	2	

Oil Pump Disassembly/Assembly

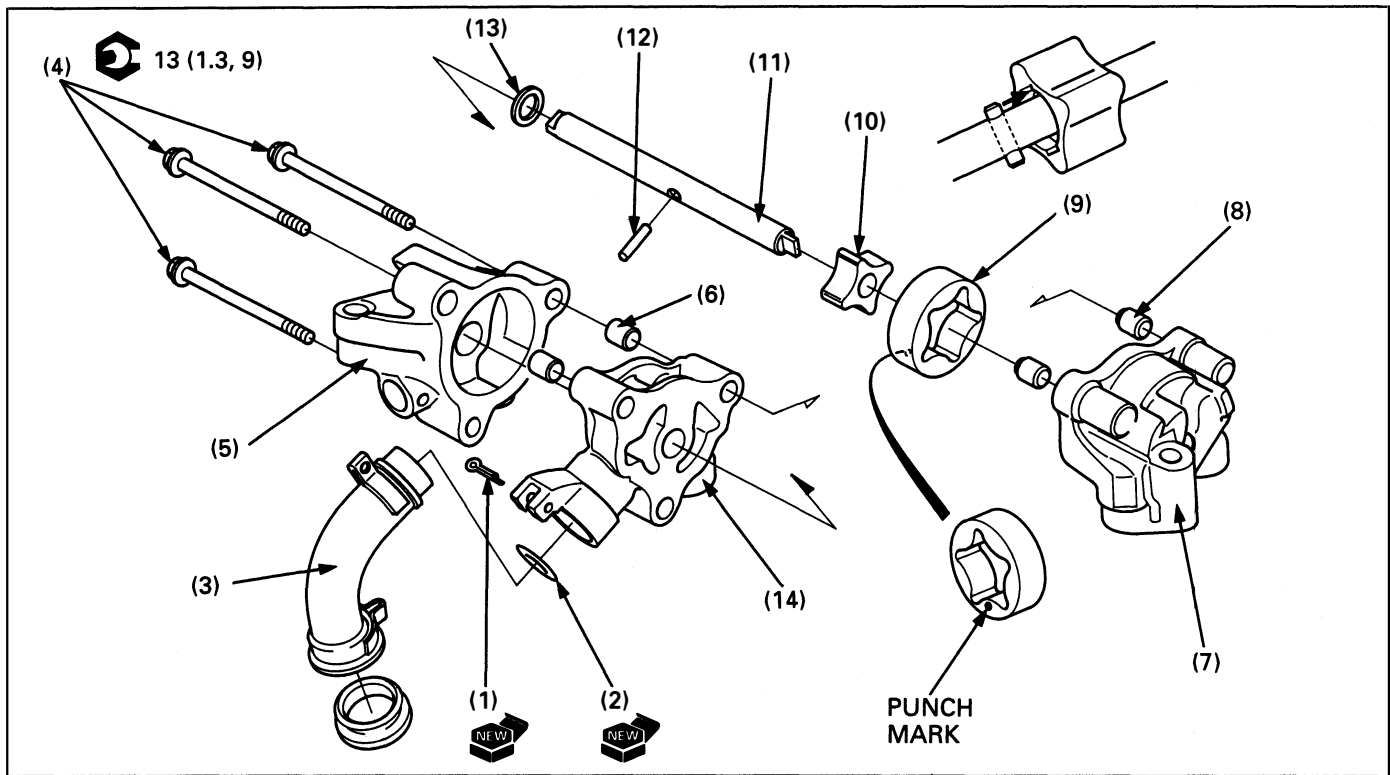

NOTE

- If any portion of the oil pump is worn beyond the specified service limit, replace it as an assembly.
- Before assembly them, clean all disassembled parts thoroughly with clean engine oil.
- Refer to section 4 of the Common Service Manual for inspection information.
- Refer to page 1-6 for specification.

Requisite Service

- Oil pump removal/installation (page 4-3)

Procedure		Q'ty	Remarks
Disassembly Order			Assembly is in the reverse order of disassembly.
(1)	Cotter pin	1	
(2)	O-ring	1	
(3)	Oil strainer pipe	1	
(4)	Bolt	3	After installation, check that the rotor shaft turns freely.
(5)	Pump cover	1	
(6)	Dowel pin	2	
(7)	Feed pump cover	1	
(8)	Dowel pin	2	
(9)	Outer rotor	1	Install with the punch mark facing the oil pump body.
(10)	Inner rotor	1	Install aligning the cut out with the drive pin.
(11)	Rotor shaft	1	
(12)	Drive pin	1	Install in the rotor shaft hole.
(13)	Washer	1	
(14)	Oil pump body	1	

5. Fuel System

Service Information	5-1	Carburetor Synchronization	5-14
Troubleshooting	5-2	Pilot Screw Adjustment	5-16
Air Cleaner Housing Removal/Installation	5-3	High Altitude Adjustment (U.S.A. Only)	5-17
Carburetor Removal/Installation	5-4	Evaporative Emission Canister (EVAP Canister) Removal/Installation (California Type Only)	5-18
Carburetor Separation	5-6	Pulse Secondary Air Injection Control Valve (PAIR Control Valve) Removal/Installation (California Type Only)	5-18
Carburetor Disassembly/Assembly	5-8		
Carburetor Combination	5-10		
Carburetor Tube Routing (California Type Only)	5-13		

Service Information

⚠ WARNING

- **Gasoline is extremely flammable and is explosive under certain conditions. KEEP OUT OF REACH OF CHILDREN.**
 - **Bending or twisting the control cables will impair smooth operation and could cause the cables to stick or bind, resulting in loss of vehicle control.**
- Work in a well ventilated area. Smoking or allowing flames or sparks in the work area or where gasoline is stored can cause a fire or explosion.

CAUTION

- **To prevent damage, be sure to removed the diaphragms before cleaning air and fuel passages with compressed air. The diaphragms might be damaged.**

- Refer to section 2 for fuel tank removal and installation.
- When disassembling fuel system parts, note the locations of the O-rings. Replace them with new ones on reassembly.
- Before removing the carburetors, place the suitable container under the carburetor drain tube, loosen the drain bolts and drain the carburetors.
- After removing the carburetor, wrap the intake port of the engine with a shop towel or cover it with pieces of tape to prevent any foreign material from dropping into the engine.
- The vacuum chamber and float chamber can be serviced with the carburetors assembled.
- California Type Only:
All hoses used in the evaporative emission control system are numbered for identification. When connecting one of these hose, compare the hose number with the Vacuum Hose Routing Diagram Label, page 1-30, and carburetor tubes routing, page 5-13.

NOTE

- If the vehicle is to be stored for more than one month, drain the float bowls. Fuel left in the float bowls may cause clogged jets resulting in hard starting or poor driveability.

Troubleshooting

Engine Won't Start

- Too much fuel getting to the engine
 - Air cleaner clogged
 - Flooded carburetor
- Intake air leak
- Fuel contaminated/deteriorated
- No fuel to carburetor
 - Fuel strainer clogged
 - Fuel tube clogged
 - Fuel valve stuck
 - Float level misadjusted
 - Fuel tank breather tube clogged

Lean Mixture

- Fuel jets clogged
- Float valve faulty
- Float level too low
- Fuel line restricted
- Carburetor air vent tube clogged
- Intake air leak
- Throttle valve faulty
- Vacuum piston faulty
- California Type Only: Evaporative emission carburetor air vent control valve faulty

Rich Mixture

- Starting enrichment valve in ON position
- Float valve faulty
- Float level too high
- Air jets clogged
- Air cleaner contaminated
- Flooded carburetor

Engine Stall, Hard To Start, Rough Idling

- Fuel line restricted
- Ignition malfunction
- Fuel mixture too lean/rich
- Fuel contaminated/deteriorated
- Intake air leak
- Idle speed misadjusted
- Float level misadjusted
- Fuel tank breather tube clogged
- Pilot screw misadjusted
- Slow circuit or starting enrichment circuit clogged
- Emission control system malfunction (California Type Only)
 - Evaporative emission carburetor air vent control valve faulty
 - Evaporative emission purge control valve faulty
 - Loose, disconnected or deteriorated hoses of the emission control system

Afterburn When Engine Braking is Used

- Lean mixture in slow circuit
- Air cut-off valve malfunction
- Emission control system malfunction (California Type Only)
 - Pulse secondary air supply system faulty
 - Loose, disconnected or deteriorated hoses of the emission control system

Backfiring Or Misfiring During Acceleration

- Ignition system faulty
- Fuel mixture too lean

Poor Performance (Driveability) And Poor Fuel Economy

- Fuel system clogged
- Ignition malfunction
- Emission control system malfunction (California Type Only)
 - Loose, disconnected or deteriorated hoses of the emission control system

Air Cleaner Housing Removal/Installation

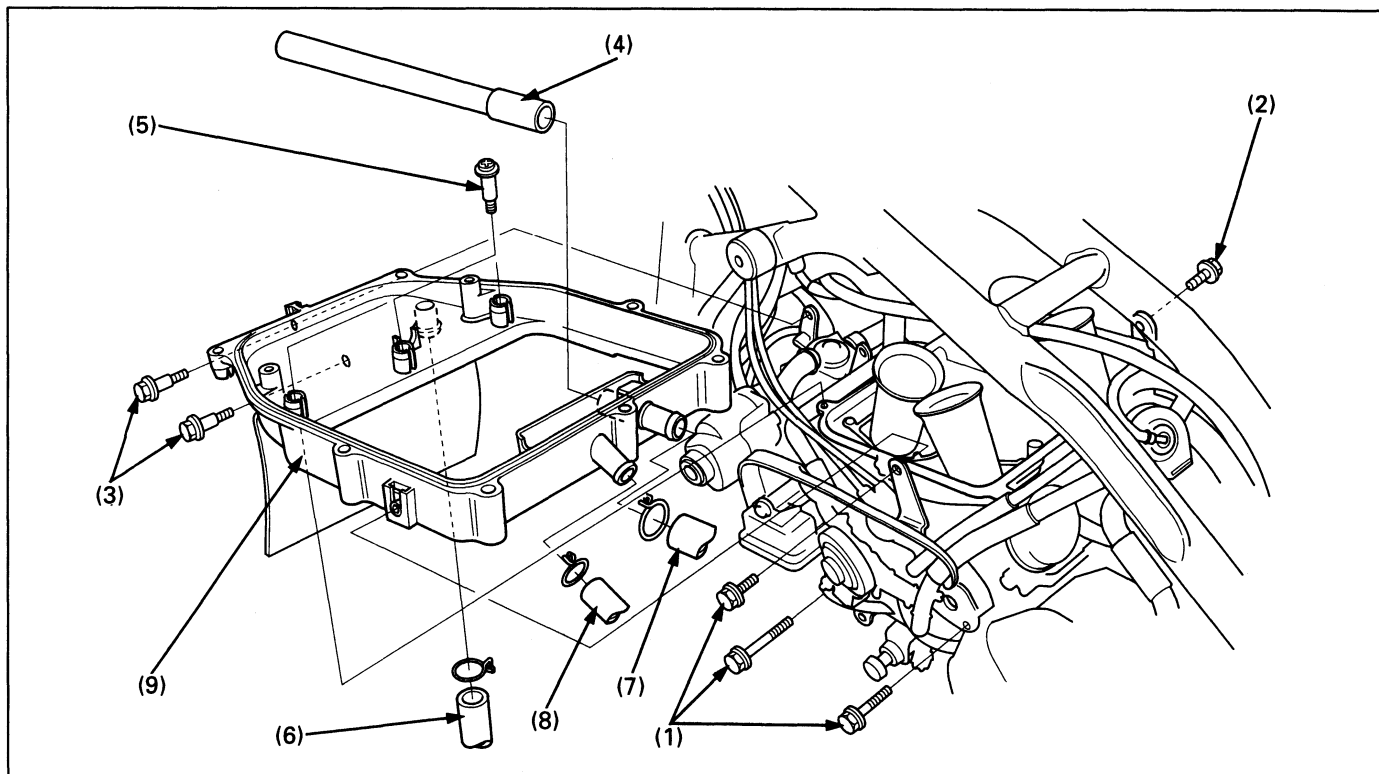

Requisite Service

- Fuel tank removal/installation (page 2-2)
- Air cleaner removal/installation (page 3-5)

Procedure	Q'ty	Remarks
Removal Order		Installation is in the reverse order of removal.
(1) Left middle cover stay bolt	3	
(2) Right middle cover stay bolt	1	
(3) Front pulse secondary air injection control valve bolt	2	California type only
(4) Rear pulse secondary air injection control valve air intake pipe	1	California type only
(5) Air cleaner housing screw	3	
(6) Front pulse secondary air injection control valve air intake tube	1	California type only
(7) Rear pulse secondary air injection control valve air intake tube	1	California type only
(8) Crankcase breather tube	1	
(9) Air cleaner housing	1	Move the air cleaner housing out of the carburetor on the left. CAUTION • Be careful not to damage the air cleaner housing during removal/ installation.

Carburetor Removal/Installation

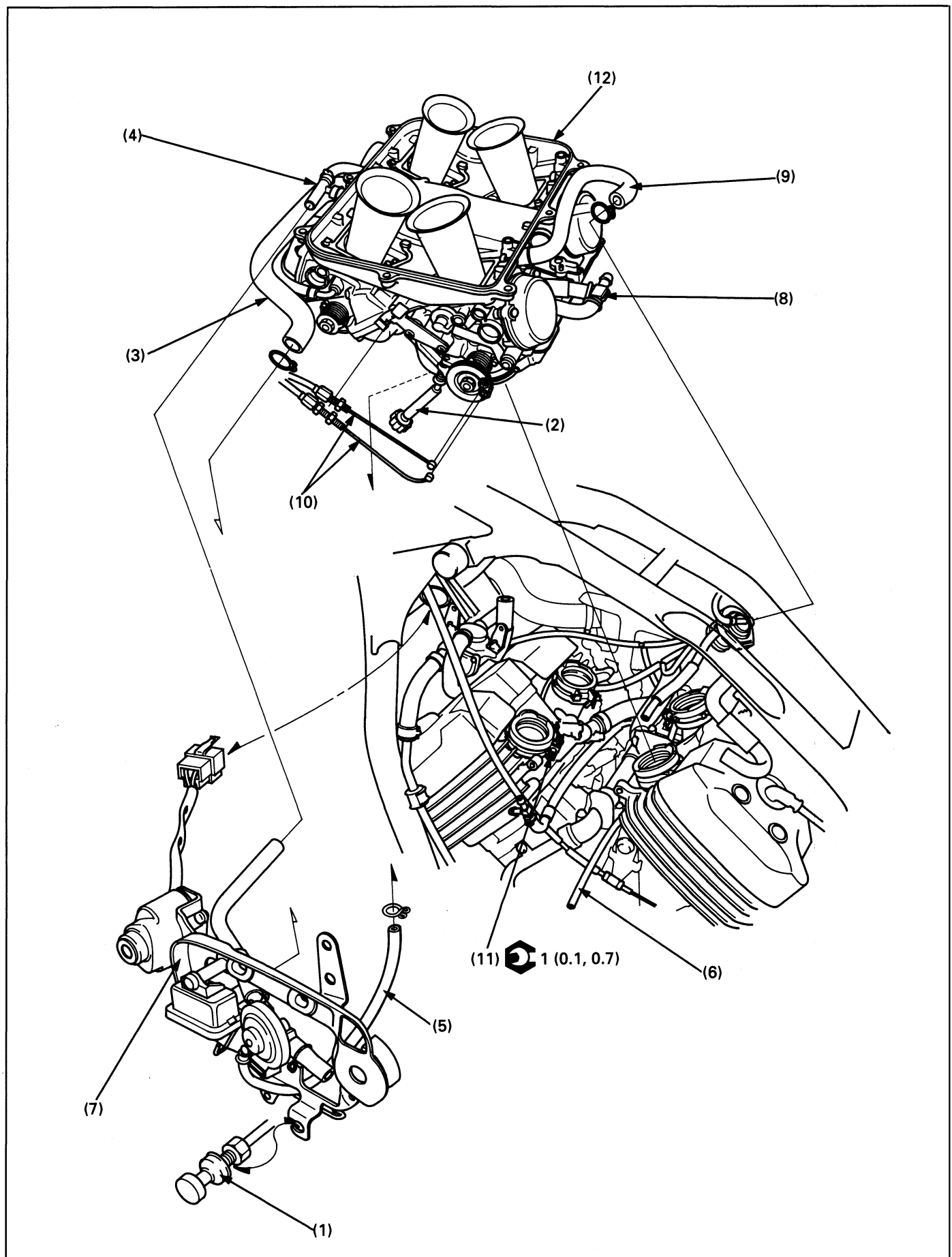

⚠ WARNING

• **Gasoline is extremely flammable and is explosive under certain conditions.**

- Work in well ventilated area. Smoking or allow flames or sparks in the working area or where gasoline is stored can cause a fire or explosion.

NOTE

• Route the cables and tubes properly (page 1-20).

Requisite Service

- Air cleaner housing removal/installation (page 5-3)
- Carburetors draining

Procedure		Q'ty	Remarks
	Removal Order		Installation is in the reverse order of removal.
(1)	Choke cable	1	Remove the choke cable from the left middle cover stay.
(2)	Throttle stop screw	1	Remove the throttle stop cable from the left middle cover stay.
(3)	Sub-air cleaner case tube	1	
(4)	No. 5 vacuum tube (from the 3 way joint)	1	California type only
(5)	No. 11 vacuum tube (from the No. 1 carburetor)	1	California type only
(6)	No. 10 vacuum tube (from the 3way joint)	1	California type only
(7)	Left middle cover stay assembly	1	Disconnect the ignition switch connector.
(8)	Fuel tube	1	
(9)	No. 6 vacuum tube (from the AVCV)	1	California type only
(10)	Throttle cable	2	
(11)	Connecting tube band screw	4	Only loosen.
(12)	Carburetor assembly	1	

Carburetor Separation

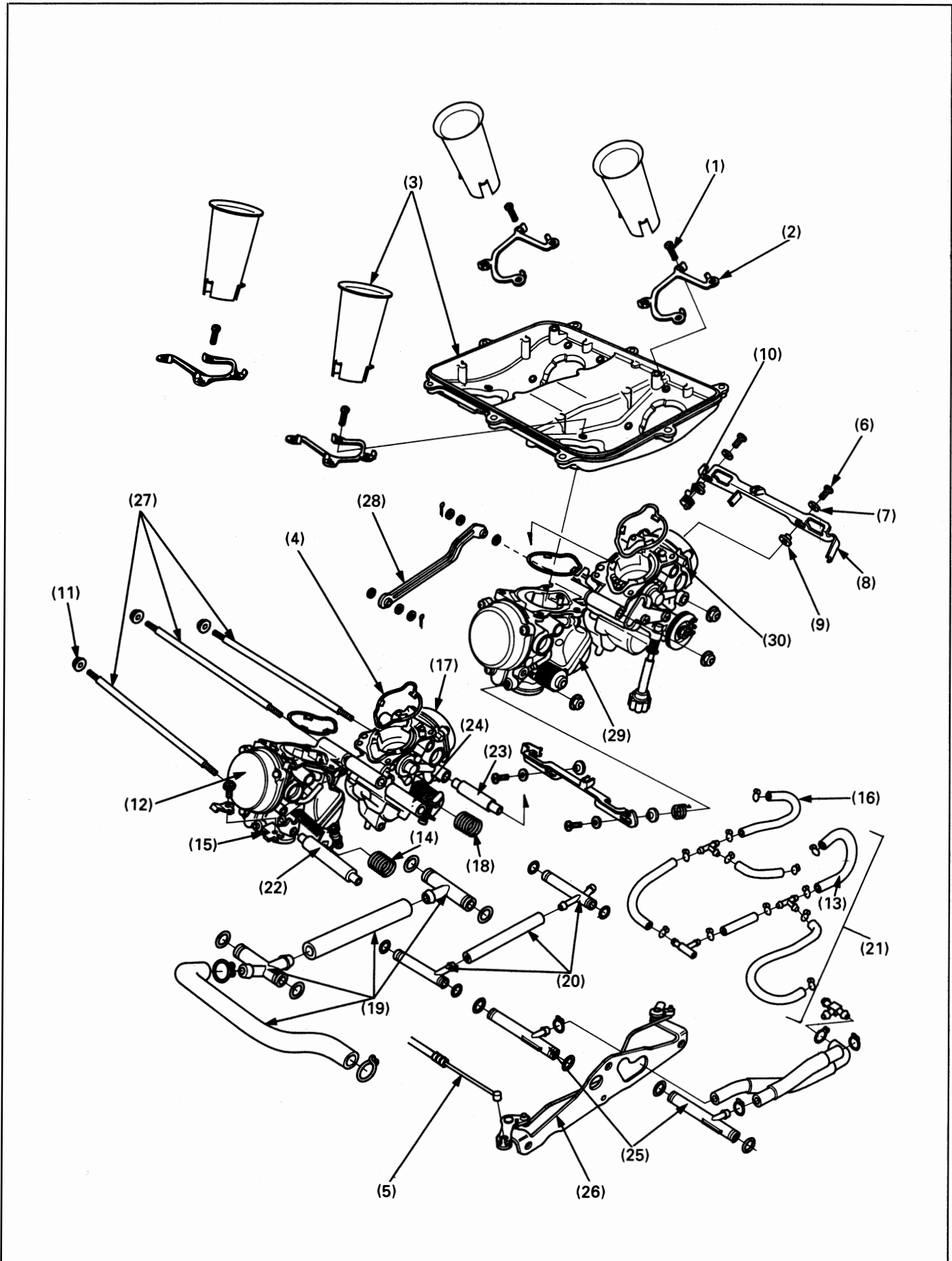

Requisite Service

- Carburetor removal/installation (page 5-4)

- Carburetor synchronization (page 5-14)

Procedure		Q'ty	Remarks
Separate No. 4 carb. from No. 1/2/3 carb.			
(1)	Air chamber screw	12	
(2)	Lock plate	4	
(3)	Air chamber/air funnel	4/4	
(4)	O-ring	4	
(5)	Choke cable	1	
(6)	Starting enrichment valve arm screw	4	
(7)	Plastic washer	4	
(8)	Starting enrichment valve arm	2	
(9)	Plastic collar	4	
(10)	Return spring	2	
(11)	Carburetor connecting nut	6	NOTE
			• Loosen the nuts gradually and alternately.
			• Do not remove the connecting bolts.
(12)	No. 4 carburetor	1	
(13)	No. 5 vacuum tube (from the No. 4 carburetor)	1	California type only
(14)	Thrust spring	1	
(15)	Choke cable holder	1	
Separate No. 3 carb. from No. 1/2 carb.			
(16)	No. 5 vacuum tube (from the No. 3 carburetor)	1	California type only
(17)	No. 3 carburetor	1	
(18)	Thrust spring	1	
(19)	Sub-air joint pipe/tube/O-ring	2/1/4	
(20)	No. 6 vacuum tube/joint pipe/O-ring	2/2/4	
(21)	No. 5 vacuum tube (from the No. 1/2 carburetor)	6/3	California type only
(22)	Front collared dowel pin	1	
(23)	Rear collared dowel pin	1	
(24)	Center collar	1	
(25)	Fuel tube/joint pipe/o-ring	2/3/6	
(26)	Starting enrichment valve link assembly	1	
Separate No. 2 carb. from No. 1 carb.			
(27)	Carburetor connecting bolt	3	
(28)	Throttle link	1	
(29)	No. 2 carburetor	1	
(30)	No. 1 carburetor	1	

Carburetor Disassembly/Assembly

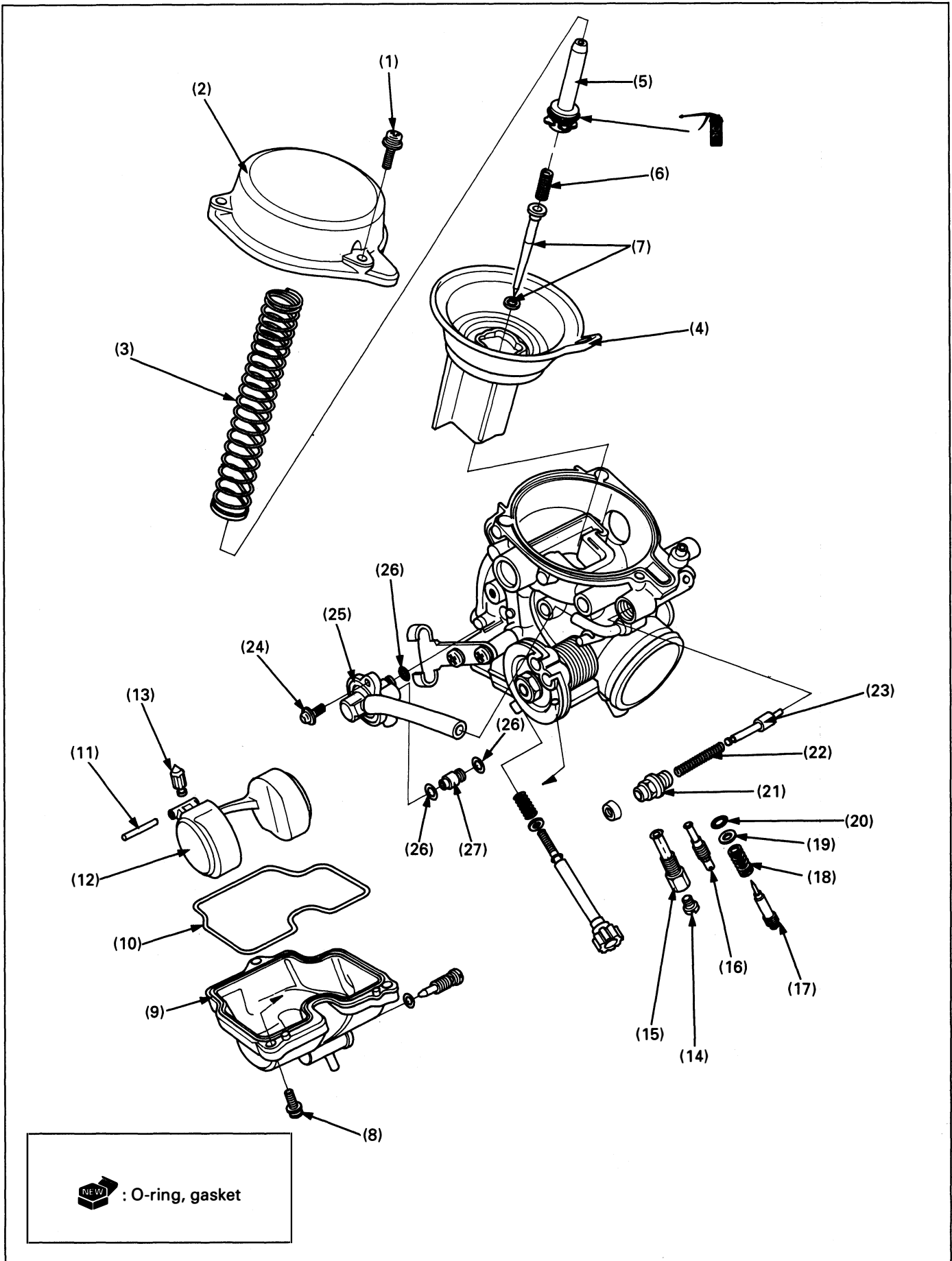

NOTE

- Vacuum chamber, float chamber and jets can be serviced without separating the carburetors.
- Note the location of the each carburetor parts so they can be back in their original location.

Requisite Service

- Carburetor separation (page 5-6)

Procedure		Q'ty	Remarks
Disassembly Order			Assembly is in the reverse order of disassembly.
Vacuum Chamber Disassembly Order			
(1)	Vacuum chamber cover screw	3	
(2)	Vacuum chamber cover	1	
(3)	Diaphragm spring	1	NOTE
(4)	Diaphragm/vacuum piston	1	• At installation, be careful not to damage the spring. NOTE
(5)	Jet needle holder	1	• At installation, align the tab of the diaphragm with the carburetor body groove.
(6)	Jet needle holder spring	1	Removal/installation (page 5-12)
(7)	Jet needle/washer	1/1	
Float Chamber Disassembly Order			
(8)	Float chamber cover screw	3	
(9)	Float chamber	1	
(10)	O-ring	1	
(11)	Float pin	1	
(12)	Float	1	
(13)	Float valve	1	
(14)	Main jet	1	
(15)	Needle jet holder	1	
(16)	Slow jet	1	
(17)	Pilot screw	1	
(18)	Spring	1	
(19)	Washer	1	
(20)	O-ring	1	
Starting Enrichment Valve Disassembly Order			
(21)	Valve nut	4	
(22)	Spring	1	
(23)	Starting enrichment valve	1	
Air Cut Off Valve Disassembly Order			
(24)	Air cut off valve cover screw	1	At installation, be sure the diaphragm and spring are properly seated, then tight them.
(25)	Air cut off valve cover	1	Do not lose the spring when valve cover removal.
(26)	O-ring	3	At installation, install the new O-ring with its flat side toward the carburetor body.
(27)	Air cut off valve	1	

Carburetor Combination

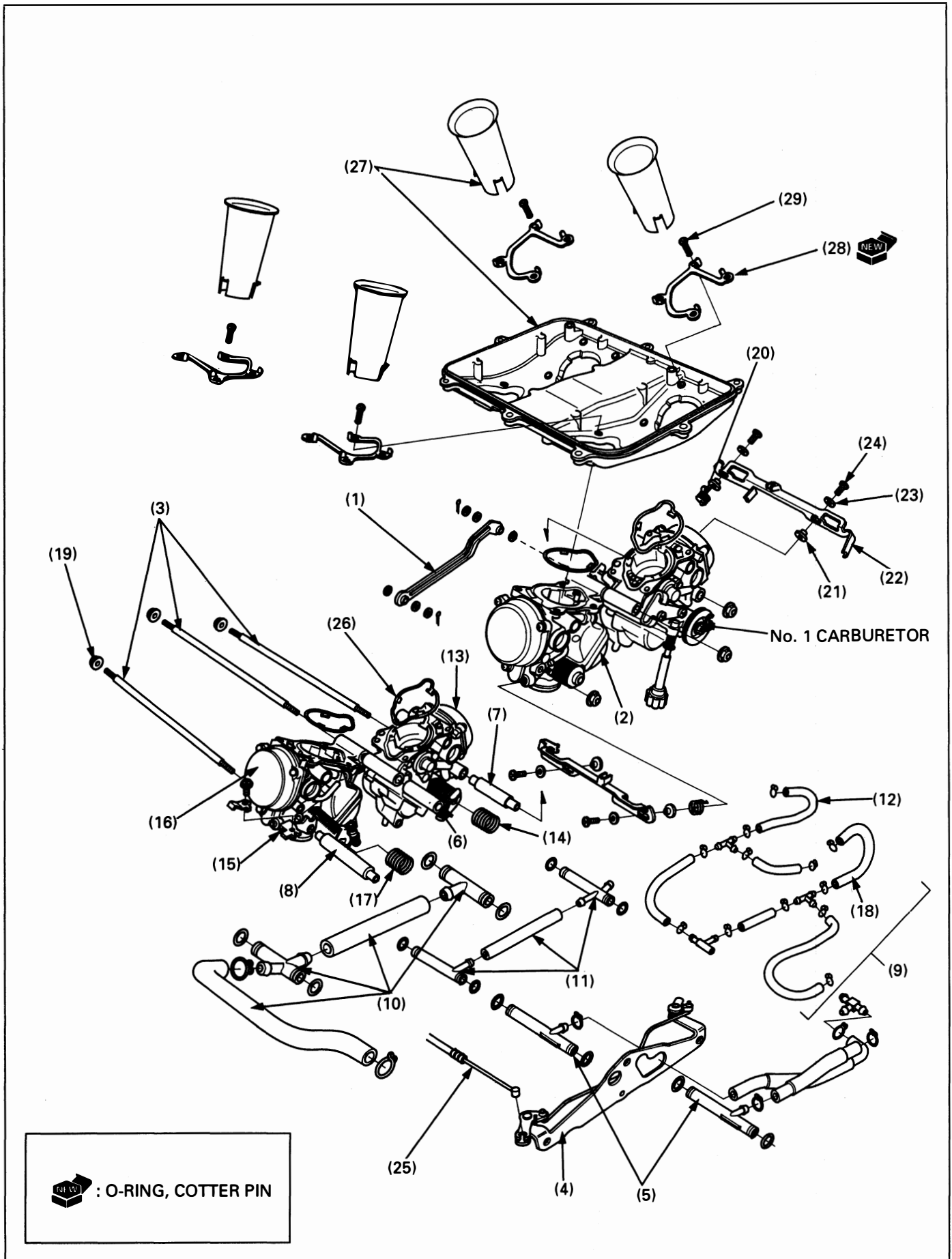

NOTE

- No. 1 carburetor is the base carburetor.
- Before tightening the carburetor connecting bolt/nut, check there is no clearance between each of the carburetor joints.
- Tighten the each connecting bolts/nuts gradually and alternately, be sure the bolt thread projections are equal high. Hold the nut and tighten the other nut on other side.

Requisite Service

- Carburetor removal/installation (page 5-4)
- Carburetor synchronization (page 5-14)

Procedure		Q'ty	Remarks	
Assemble No. 2 carb. with No.1 carb.				
(1)	Throttle link	1	Refer to the drawing for the combination of the washer.	
(2)	No. 2 carburetor	1		
(3)	Carburetor connecting bolt	3		
Assemble No. 3 carb. with No. 1/2 carb.				
(4)	Starting enrichment valve link assembly	1	California type only	
(5)	Fuel tube/joint pipe/O-ring	2/3/6		
(6)	Center collar	1		
(7)	Rear collared dowel pin	1		
(8)	Front collared dowel pin	1		
(9)	No. 5 vacuum tube (to the No. 1/2 carburetor)	6/3		
(10)	Sub-air joint pipe/tube/O-ring	2/1/4		
(11)	No. 6 vacuum tube/joint pipe/O-ring	2/2/4		
(12)	No. 5 vacuum tube (to the No. 3 carburetor)	1		California type only
(13)	No. 3 carburetor	1		
(14)	Thrust spring	1		
Assemble No. 4 carb. with No. 1/2/3 carb.				
(15)	Choke cable holder	1		California type only CAUTION • Tighten each nuts gradually and alternately with the above procedure. Do not over-tighten the nuts.
(16)	No. 4 carburetor	1		
(17)	Thrust spring	1		
(18)	No. 5 vacuum tube (to the No. 4 carburetor)	1		
(19)	Carburetor connecting nut	6		
(20)	Return spring	2		
(21)	Plastic collar	4		
(22)	Starting enrichment valve arm	2		
(23)	Plastic washer	4		
(24)	Starting enrichment valve arm screw	4		
(25)	Choke cable	1		
(26)	O-ring	4		
(27)	Air chamber/air funnel	4/4		
(28)	Lock plate	4		
(29)	Air chamber screw	12		

Fuel System

Jet Needle Holder Removal/Installation

Removal

Remove the vacuum piston (page 5-8).

Temporarily install the 4 mm screw or equivalent (Example; vacuum chamber screw).

Pull the screw and remove the jet needle holder.

CAUTION

- Be careful not to damage the diaphragm.
- Do not remove the jet needle holder by pushing the jet needle.

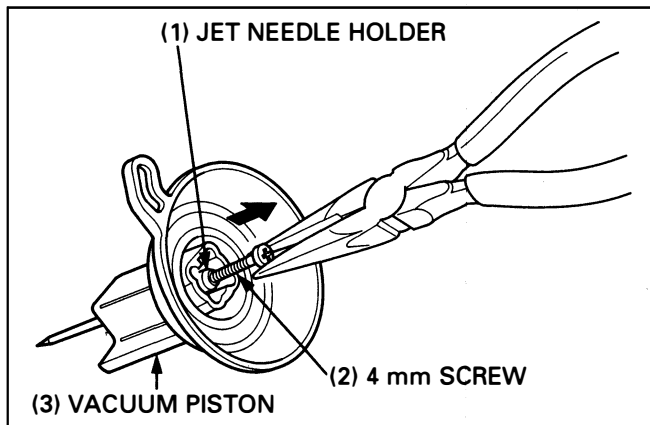

Installation

Install the jet needle holder into the vacuum piston until you felt the click.

Install the vacuum piston (page 5-8).

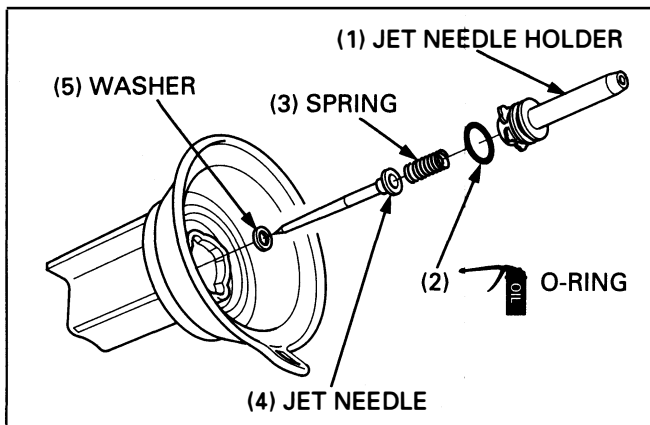

Carburetor Body Cleaning

Clean the fuel strainer in the float valve using the compressed air from the float valve seat side.

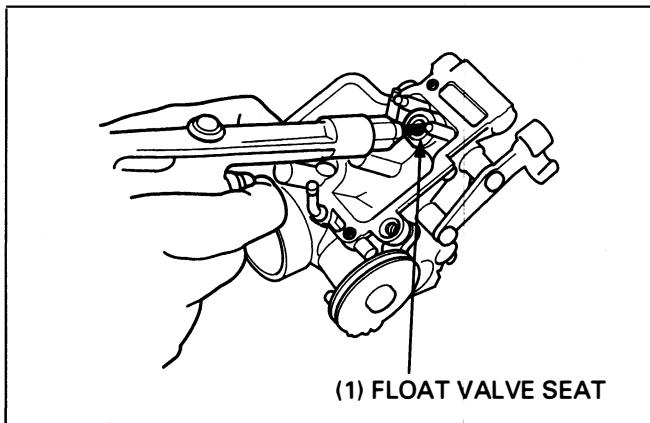

Carburetor Tube Routing (California Type Only)

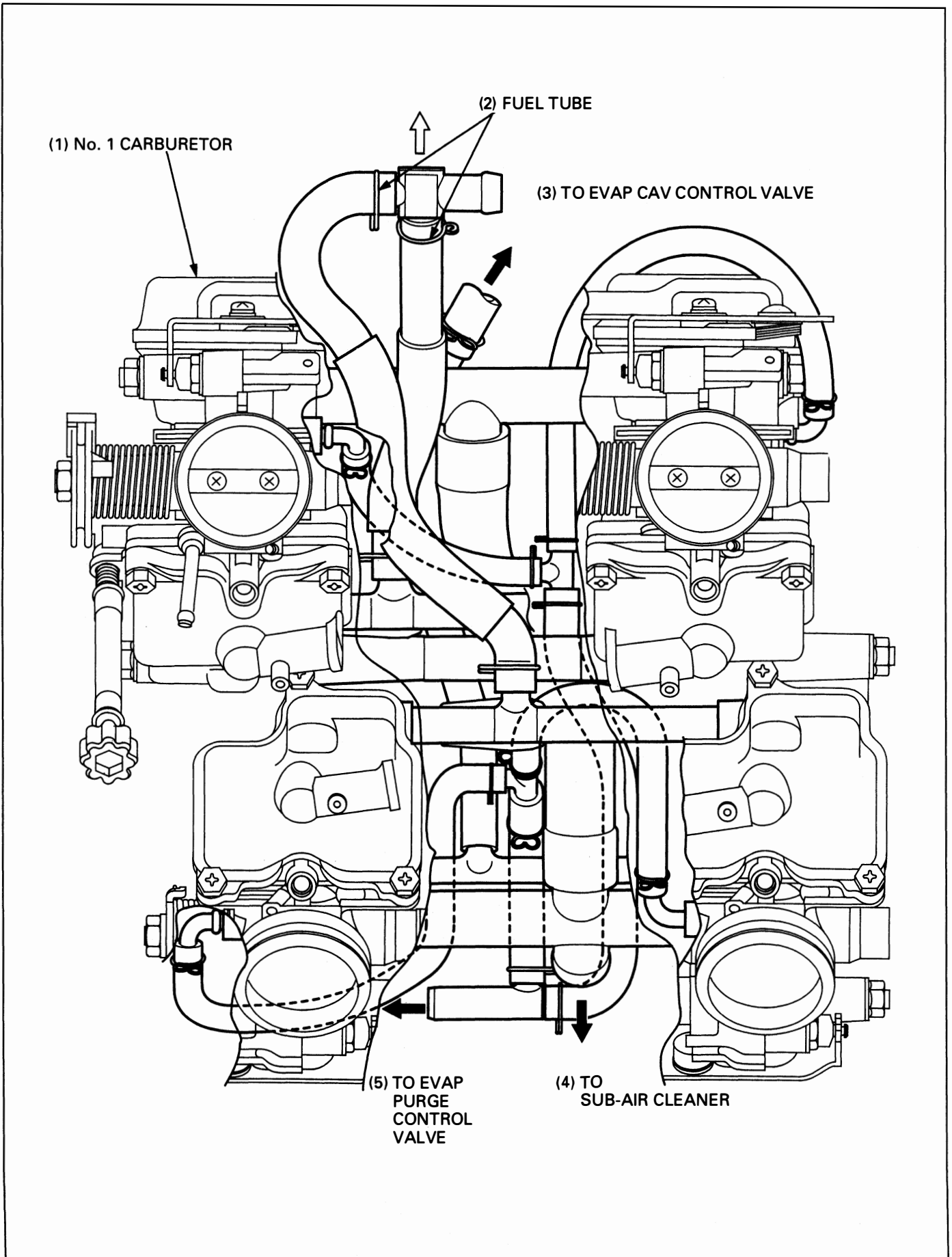

Carburetor Synchronization

NOTE

- Refer to section 2 of the Common Service Manual for carburetor synchronization procedure.
- Synchronize the carburetors with the engine at normal operating temperature, the transmission in neutral and the motorcycle supported securely on a level surface.

Remove the left and right middle covers.

Remove the No. 2 cylinder intake port vacuum plug.

Connect the vacuum gauge adaptor to the No. 2 cylinder intake port.

Disconnect the No. 4 cylinder vacuum tube from the engine intake port, apply vacuum to the disconnected tube and pinch the tube with a clip.

Connect the vacuum gauge tube to the No. 4 cylinder intake port adaptor.

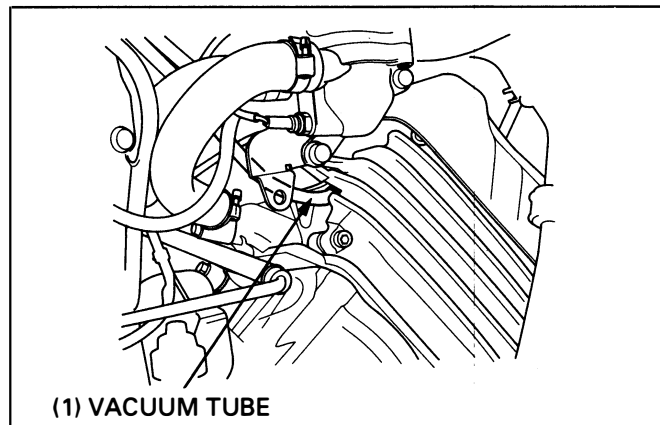
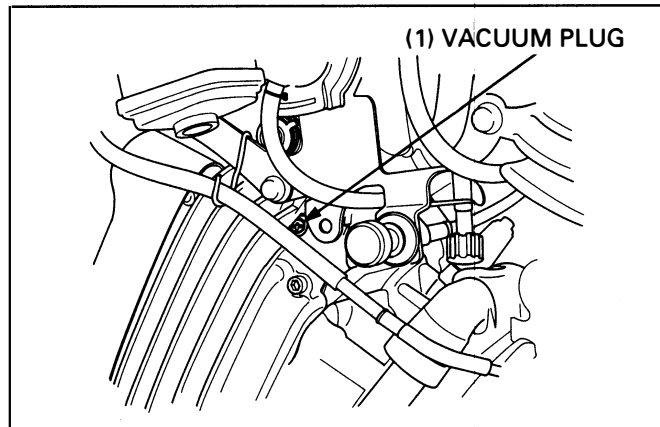

49 States type:

Remove the No. 1 cylinder intake port vacuum plug.

Connect the vacuum gauge adaptor to the No. 1 cylinder intake port.

California type:

Disconnect the No. 1 cylinder vacuum tube from the engine intake port.

Connect the vacuum gauge tube to the No. 1 cylinder intake port adaptor.

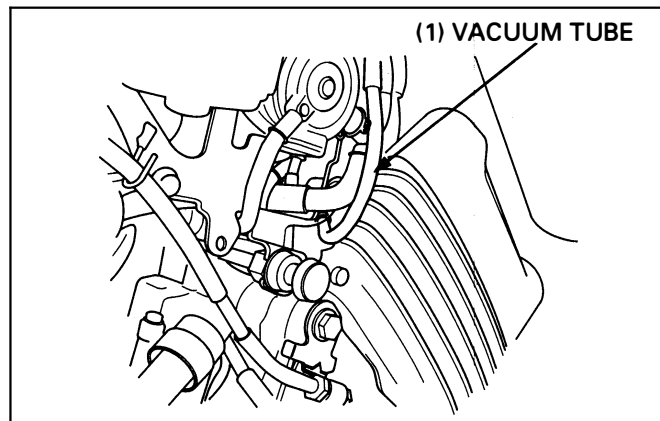

49 States type:

Remove the No. 3 cylinder intake port vacuum plug.

Connect the vacuum gauge adaptor to the No. 3 cylinder intake port.

California type:

Disconnect the No. 3 cylinder vacuum tube from the engine intake port.

Connect the vacuum gauge tube to the No. 3 cylinder intake port adaptor.

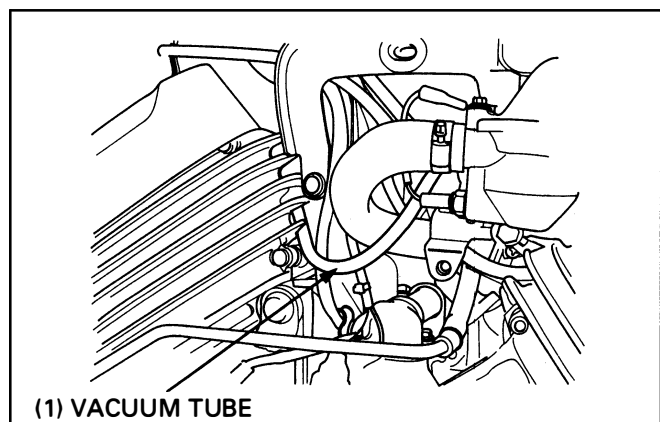

Start the engine.
Turn the throttle stop screw knob and adjust the idle speed.

Idle speed: 49 states type: $1,000 \pm 100$ rpm
California type: $1,100 \pm 100$ rpm
Canadian type: $1,000 \pm 100$ rpm

Check the each carburetor intake vacuum pressure is within 20 mm (0.8 in) Hg of the base carburetor.

NOTE

- The base carburetor is the No. 1 carburetor.

Synchronize to specification by turning the adjusting screws.

Recheck the idle speed and each cylinder intake vacuum pressure so it is within 20 mm (0.8 in) Hg of the base carburetor reading after snapping the throttle grip 3 – 4 times.

Remove the vacuum gauge and adaptors.

(1) THROTTLE STOP SCREW KNOB

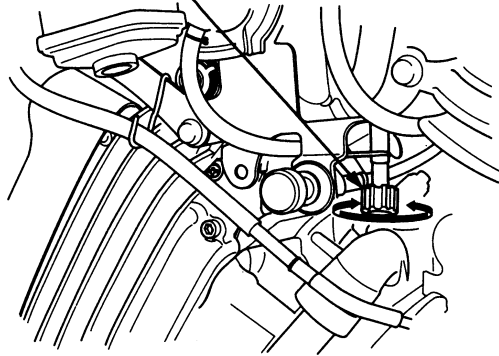

(1) SCREW (No. 3 CARBURETOR)

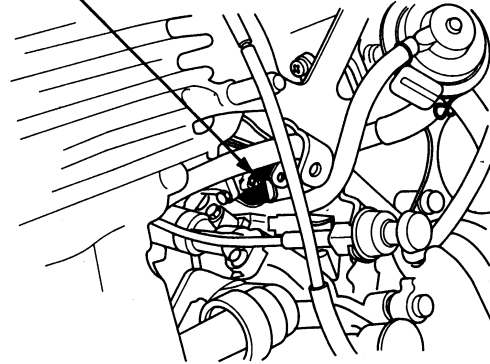

(1) SCREWS
(No. 2, 4 CARBURETOR)

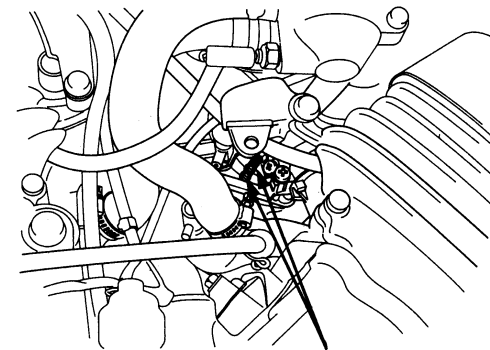

Fuel System

Pilot Screw Adjustment

Idle Drop Procedure

⚠ WARNING

- If the engine must be running to do some work, make sure the area is well ventilated. Never run the engine in an enclosed area.
- The exhaust contains poisonous carbon monoxide gas that may cause loss of consciousness and may lead to death.

NOTE

- Make sure the carburetor synchronization is within specification before pilot screw adjustment (page 5-14).
- The pilot screw is factory pre-set and no adjustment is necessary unless it is replaced.
- The engine must be warm for accurate adjustment. Ten minutes of stop-and-go riding is sufficient.
- Use a tachometer with graduation of 50 rpm or smaller that will accurately indicate a 50 rpm change.

1. Using the special pilot screw wrench, turn each pilot screw clockwise until it seats lightly. Then back it out to the specification.

CAUTION

- Damage to the pilot screw seat will occur if the pilot screw is tightened against the seat.

S. TOOL

Pilot screw wrench: Canadian type: 07908 – 4220201
49 states, California type: 07MMA – MV9010A

Initial Opening: 49 states type: 2-1/2 turns out
California, Canadian type: 2-3/8 turns out

2. Warm up the engine to operating temperature.
3. Stop the engine and attach the tachometer according to the manufacturer's instruction.
4. Start the engine and adjust the idle speed with the throttle stop screw knob.

Idle Speed: 49 states type: 1,000 ± 100 rpm
California, Canadian type: 1,100 ± 100 rpm

5. Turn No.1 carburetor pilot screw in or out slowly to obtain the highest engine speed.
6. Perform step 5 for all the carburetor pilot screws.
7. Lightly open the throttle 2 – 3 times, adjust the idle speed with the throttle stop screw.
8. Turn No.1 carburetor pilot screw in gradually until the engine speed drops 50 rpm.
9. Turn No.1 carburetor pilot screw counterclockwise to the final opening from the position in step 8.

Final Opening: 49 states type: 3/4 turns out from step 8
California, Canadian type: 1/4 turns out from step 8

10. Perform steps 8 and 9 for the No. 2, 3 and 4 carburetor pilot screws.

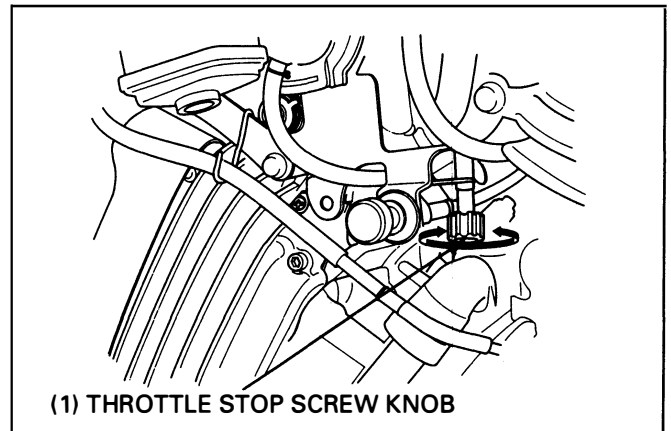
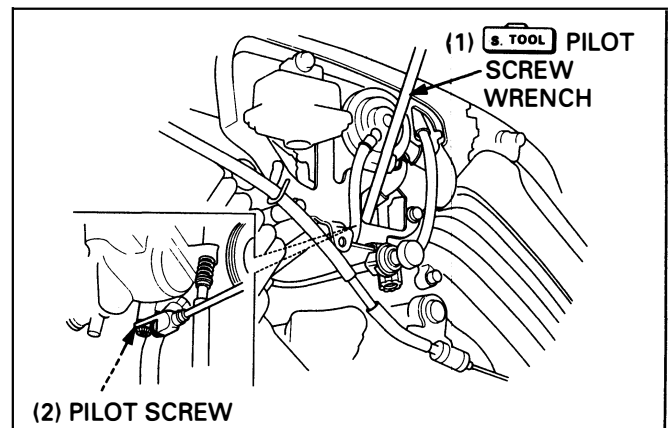

High Altitude Adjustment (U. S. A. Only)

When the vehicle is to be operated continuously above 2,000 m (6,500 feet), the carburetors must be readjusted as follows to improve driveability and decrease exhaust emission.

Warm up the engine to operating temperature. Stop and go riding for ten minutes is sufficient.

Turn each pilot screw clockwise 1/2 turn.

High Altitude Adjustment: 1/2 turn in

S. TOOL

Pilot screw wrench **07908 - 4220201**
07MMA - MV9010A
(U.S.A. only)

Adjust the idle speed to 1,000 ± 100 rpm (California: 1,100 ± 100 rpm) with the throttle stop screw knob.

NOTE

- This adjustment must be made at high altitude to ensure proper high altitude operation.

Attach a Vehicle Emission Control Information Label on the right down tube as shown in the label position illustration.

NOTE

- Do not attach the label to any part that can be easily removed from the vehicle.

▲ WARNING

- **Sustained operation at an altitude lower than 1,500 m (5,000 feet) with the carburetor adjusted for high altitude may cause the engine to idle roughly and the engine may stall in traffic. It may also cause engine damage due to overheating.**

When the vehicle is to be operated continuously below 1,500 m (5,000 feet), turn each pilot screw counterclockwise 1/2 turn to its original position and adjust the idle speed to 1,000 ± 100 rpm (California: 1,100 ± 100 rpm). Be sure to make these adjustment at low altitude.

Remove the Vehicle Emission Control Update Label that is attached to the right down tube after adjusting for low altitude.

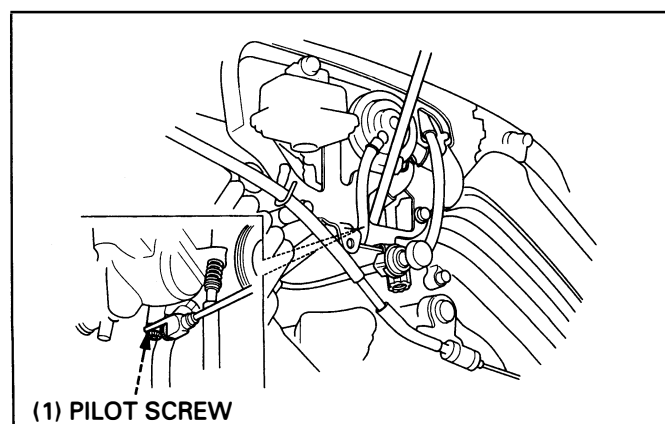
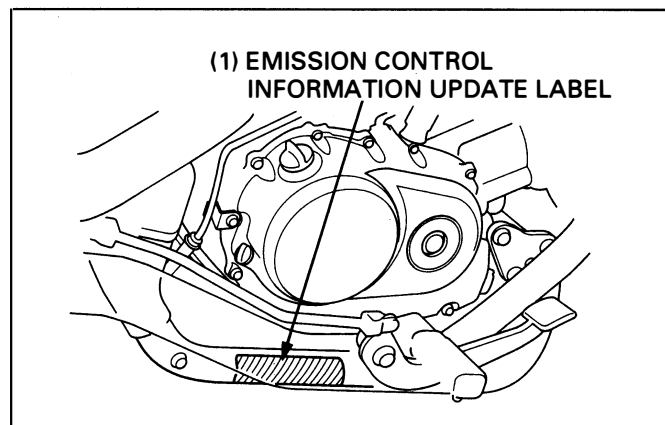
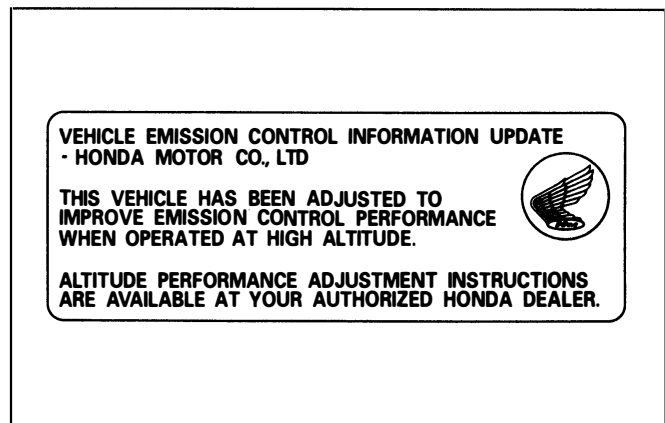
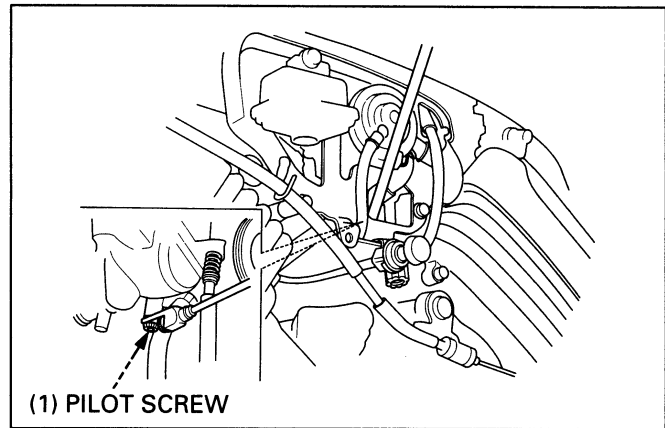

Evaporative Emission Canister (EVAP Canister) Removal/Installation (California Type Only)

Disconnect the No. 4 tube.
Disconnect the No. 1 tube.
Remove the bolts and EVAP canister.

Installation is in the reverse order of removal.

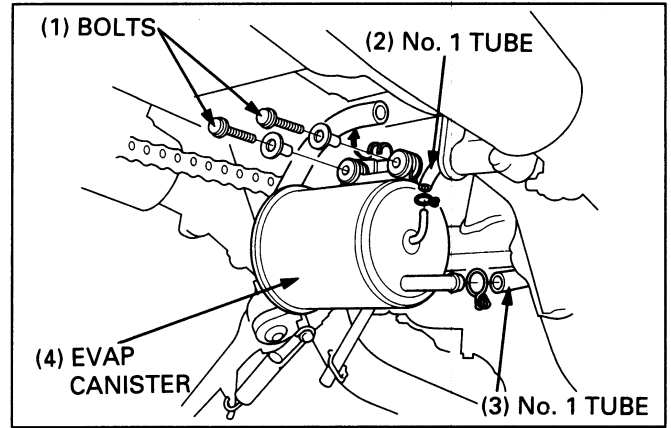

Pulse Secondary Air Injection Control Valve (PAIR Control Valve) Removal/Installation (California Type Only)

CAUTION

- To prevent damage to the PAIR control valve, do not use high air pressure sources. Use a hand operated air pump only.

Front cylinder

Remove the radiator (page 6-5).

Disconnect and remove the following:

- No. 10 vacuum tube
- air injection hose
- PAIR control valve mounting bolt
- air intake hose
- PAIR control valve

Installation is in the reverse order of removal.

After installing, check the tubes for loose connections and kinks.

Install the radiator (page 6-5).

Rear cylinder

Remove the seat (page 2-2).

Disconnect and remove the following:

- air intake hose
- air injection hose
- PAIR control valve mounting bolt
- No. 10 vacuum tube
- PAIR control valve

Installation is in the reverse order of removal.

After installing, check the tubes for loose connections and kinks.

Install the seat (page 2-2).

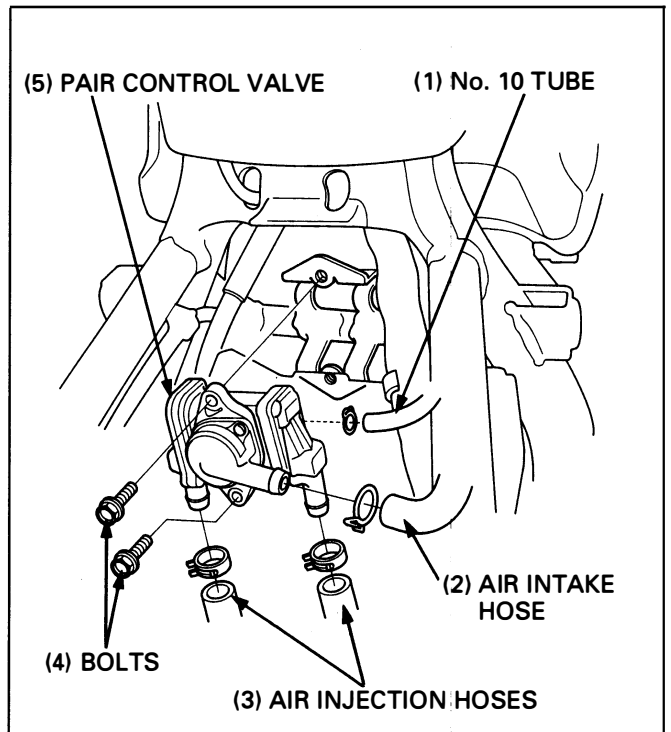
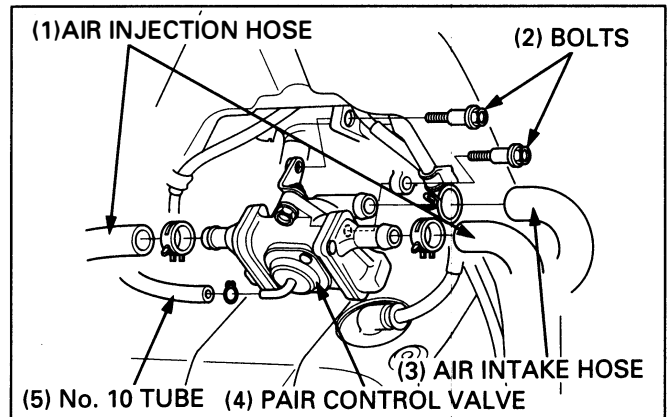

6. Cooling System

Service Information	6-1	Thermostat Removal/Installation	6-4
Troubleshooting	6-1	Radiator Removal/Installation	6-5
System Flow Pattern	6-2	Radiator Disassembly/Assembly	6-6
Coolant Draining	6-3	Water Pump Removal/Installation	6-7

Service Information

⚠ WARNING

- **Wait until the engine is cool before slowly removing the radiator cap. Removing the cap while the engine is hot and the coolant is under pressure may cause serious scalding.**
- **Radiator coolant is toxic. Keep it away from eyes, mouth, skin and clothes.**
 - **If any coolant gets in your eyes, rinse them with water and consult a doctor immediately.**
 - **If any coolant is swallowed, induce vomiting, gargle and consult a physician immediately.**
 - **If any coolant gets on your skin or clothes, rinse thoroughly with plenty of water.**
- **KEEP OUT OF REACH OF CHILDREN.**

- Add coolant at the reserve tank. Do not remove the radiator cap except to refill or drain the system.
- All cooling system services can be done with the engine in the frame.
- Avoid spilling coolant on painted surfaces.
- After servicing the system, check for leaks with a cooling system tester.
- Refer to section 25 of the Common Service Manual for fan motor switch and thermo sensor inspection.

Troubleshooting

Engine Temperature Too High

- Faulty radiator cap
- Insufficient coolant
- Passages blocked in radiator, hoses or water jacket
- Air in system
- Faulty water pump
- Thermostat stuck closed
- Faulty temperature gauge or thermo sensor
- Faulty cooling fan motor
- Faulty fan motor switch
- Incorrect fan shroud installation

Engine Temperature Too Low

- Faulty temperature gauge or thermo sensor
- Thermostat stuck open
- Faulty cooling fan motor switch

Coolant Leaks

- Faulty water pump mechanical seal
- Deteriorated/faulty O-rings
- Damaged or deteriorated gasket
- Loose hose connection or clamp
- Damaged or deteriorated hose
- Faulty radiator cap

System Flow Pattern

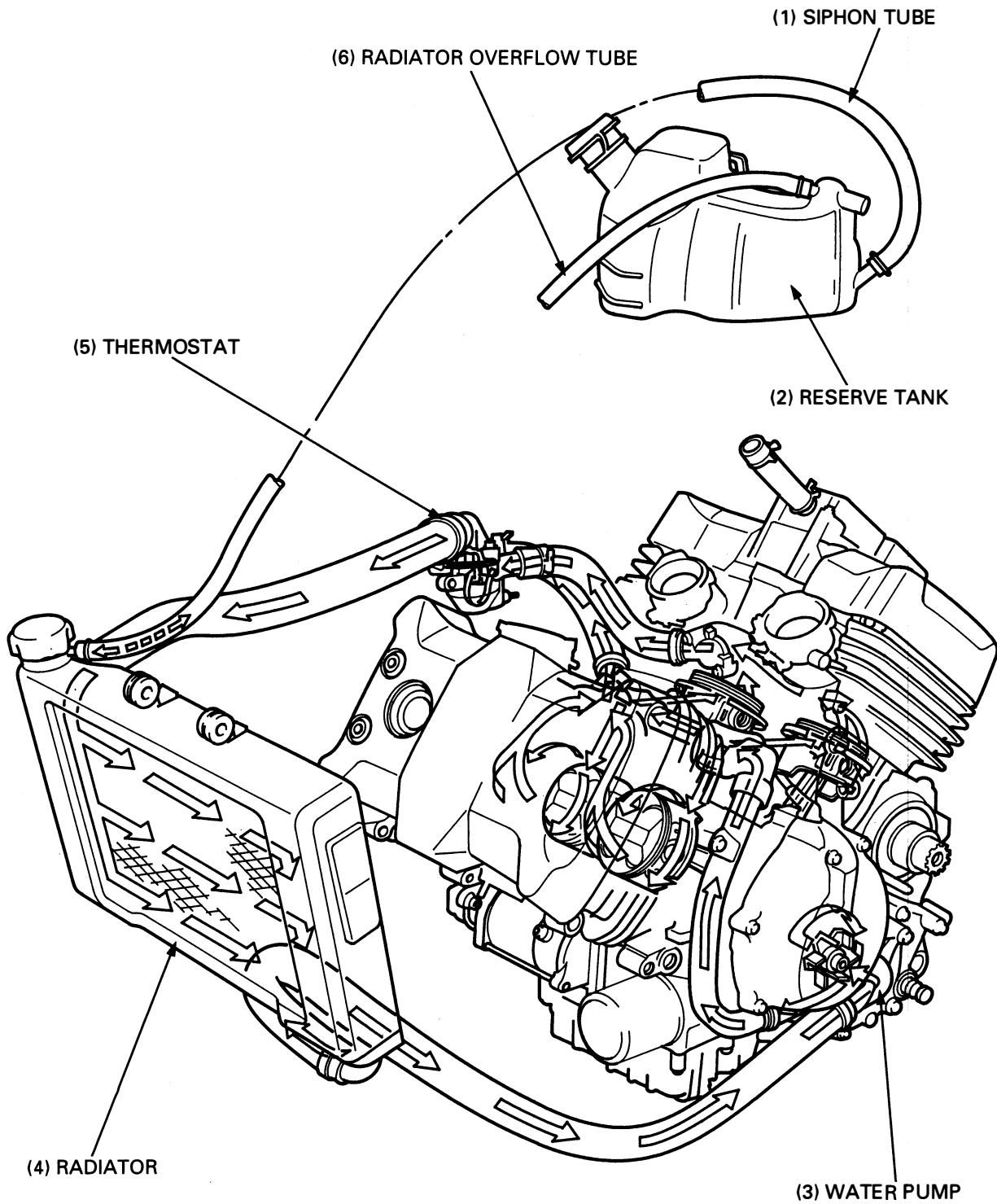

Coolant Draining

⚠ WARNING

- Wait until the engine is cool before servicing the cooling system. Removing the radiator cap while the engine is hot and the coolant is under pressure may cause serious scalding.

NOTE

- For coolant replacement, refer to section 5 of the Common Service Manual.

Remove the water pump drain bolt and sealing washer.

Remove the radiator cap screw and radiator cap and drain the coolant.

Remove the cylinder drain bolts and sealing washers and drain the coolant.

Install the water pump drain bolt with a new sealing washer.

Install the cylinder drain bolts with new sealing washers.

Refill the coolant to upper level.

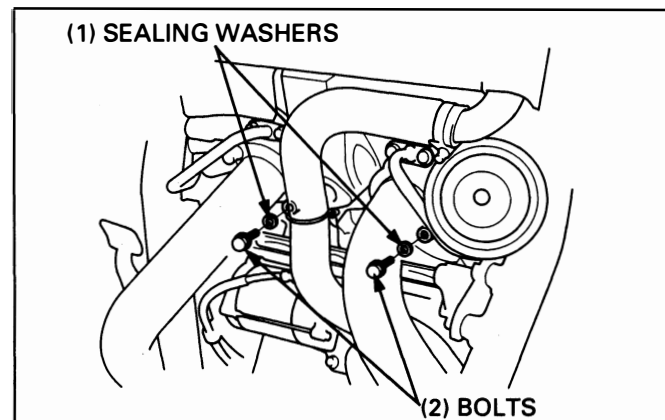
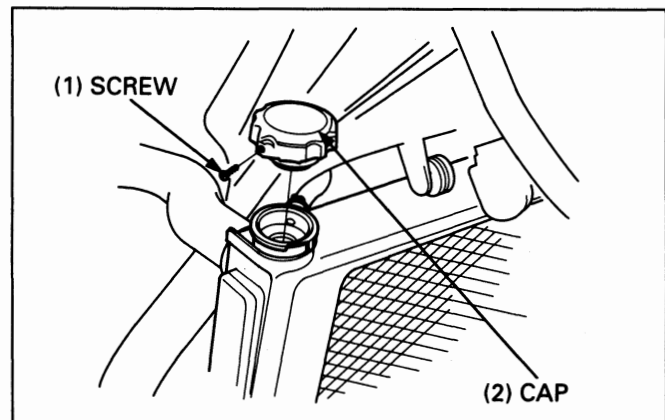
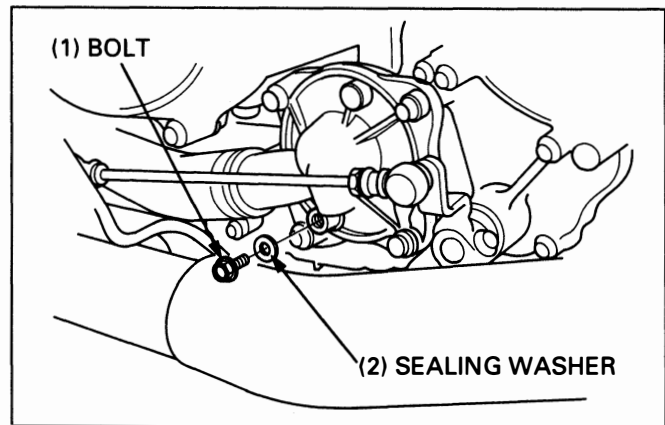

Thermostat Removal/Installation

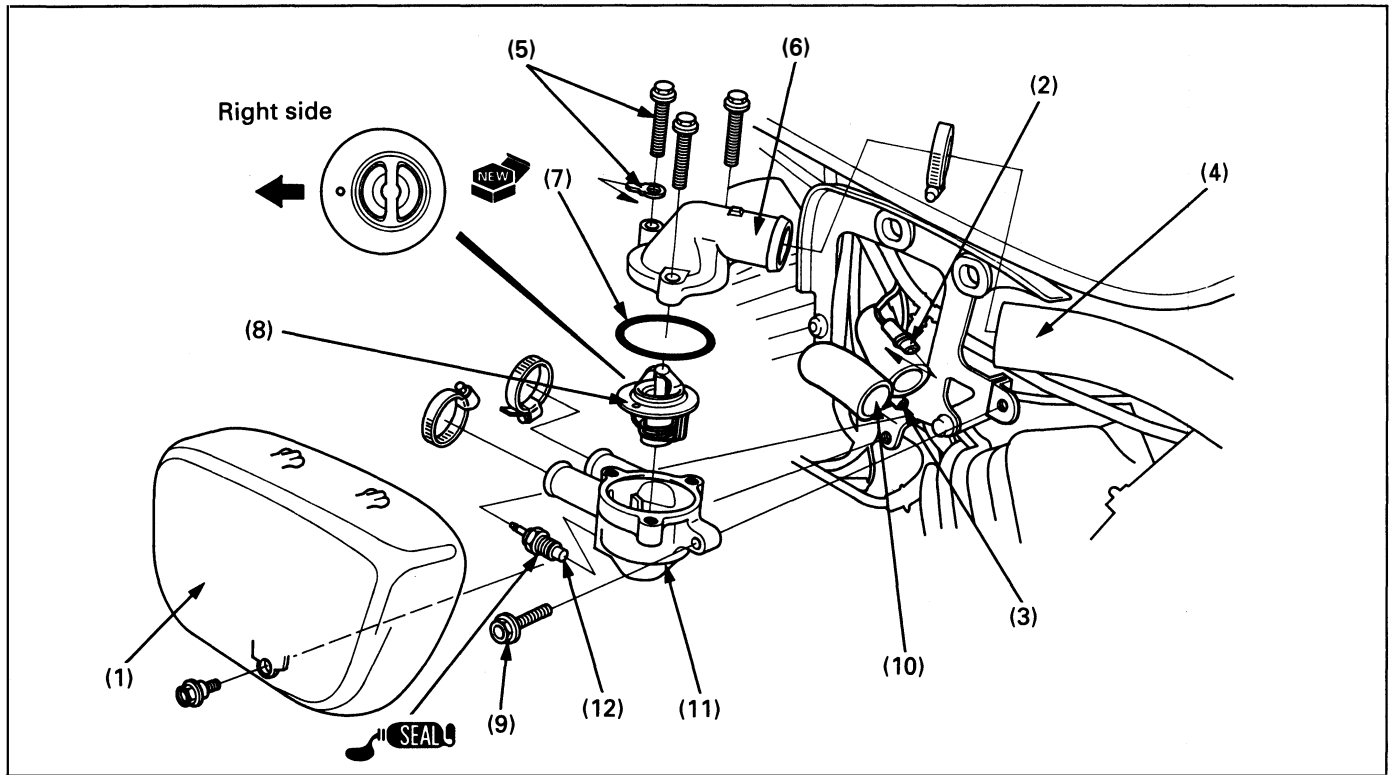

Requisite Service

- Coolant draining (page 6-3)
- Coolant refilling (Section 5 of the Common Service Manual)

Procedure	Q'ty	Remarks
Removal Order		Installation is in the reverse order of removal.
(1) Right middle cover	1	
(2) Ground wire connector	1	
(3) Thermo sensor connector	1	
(4) Radiator upper hose	1	Loosen the clamp screw and disconnect the hose.
(5) Thermostat housing cover bolt/terminal	3/1	
(6) Thermostat housing cover	1	
(7) O-ring	1	
(8) Thermostat	1	At installation, install the thermostat with its bleed hole facing right side while aligning it with the grooves in the housing.
(9) Thermostat housing bolt	1	
(10) Cylinder head-to-housing hose	2	Loosen the clamp screws and disconnect the hoses.
(11) Thermostat housing	1	
(12) Thermo sensor	1	At installation, apply sealant to the threads of the sensor.

Radiator Removal/Installation

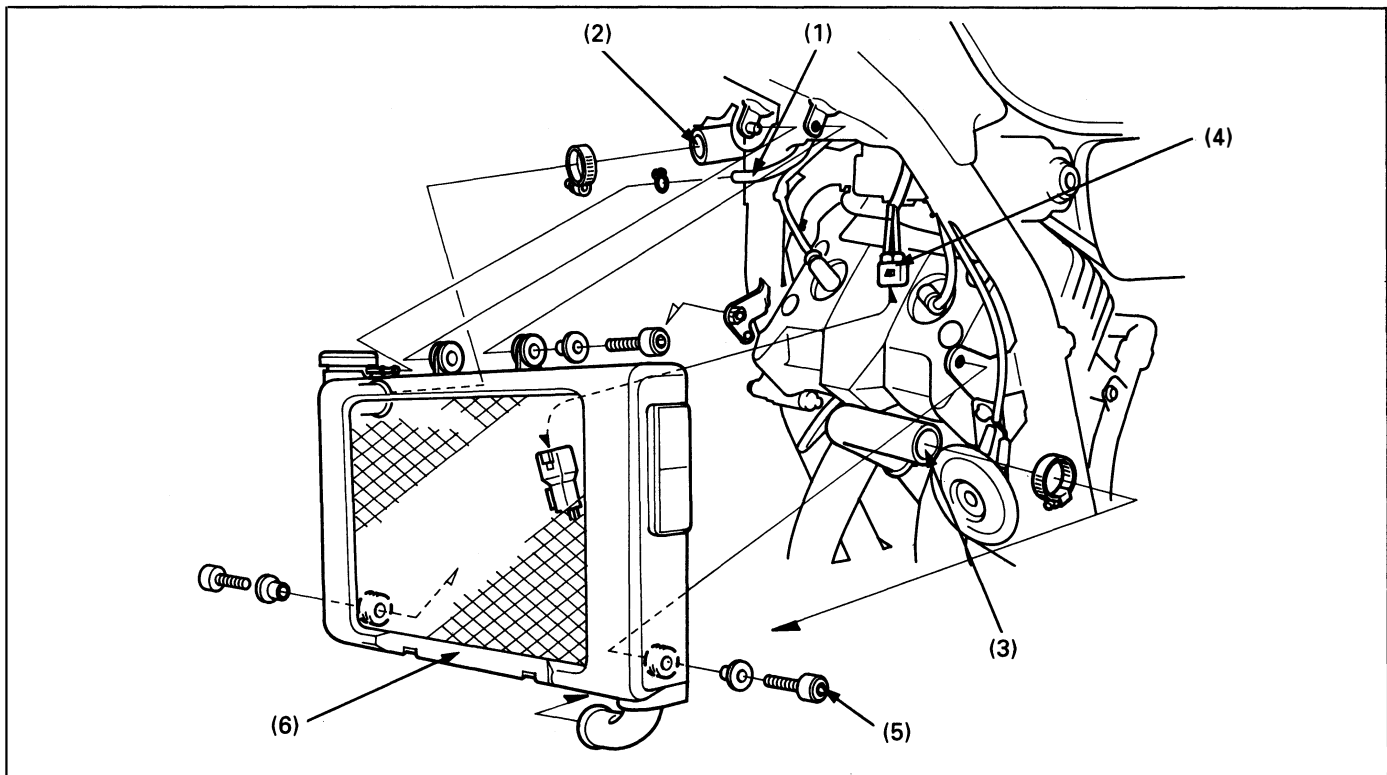

Requisite Service

- Coolant draining (page 6-3)
- Coolant refill (Section 5 of the Common Service Manual)
- Front side cover removal/installation (page 2-3)

Procedure	Q'ty	Remarks
Removal Order		Installation is in the reverse order of removal.
(1) Radiator siphon tube	1	
(2) Radiator upper hose	1	Loosen the clamp screw and disconnect the hose.
(3) Radiator lower hose	1	Loosen the clamp screw and disconnect the hose.
(4) Fan motor switch connector	1	
(5) Radiator mounting bolt	3	
(6) Radiator assembly	1	Remove it after releasing the projection on the right radiator stay. CAUTION • During removal and installation, be careful not to damage the radiator core.

Radiator Disassembly/Assembly

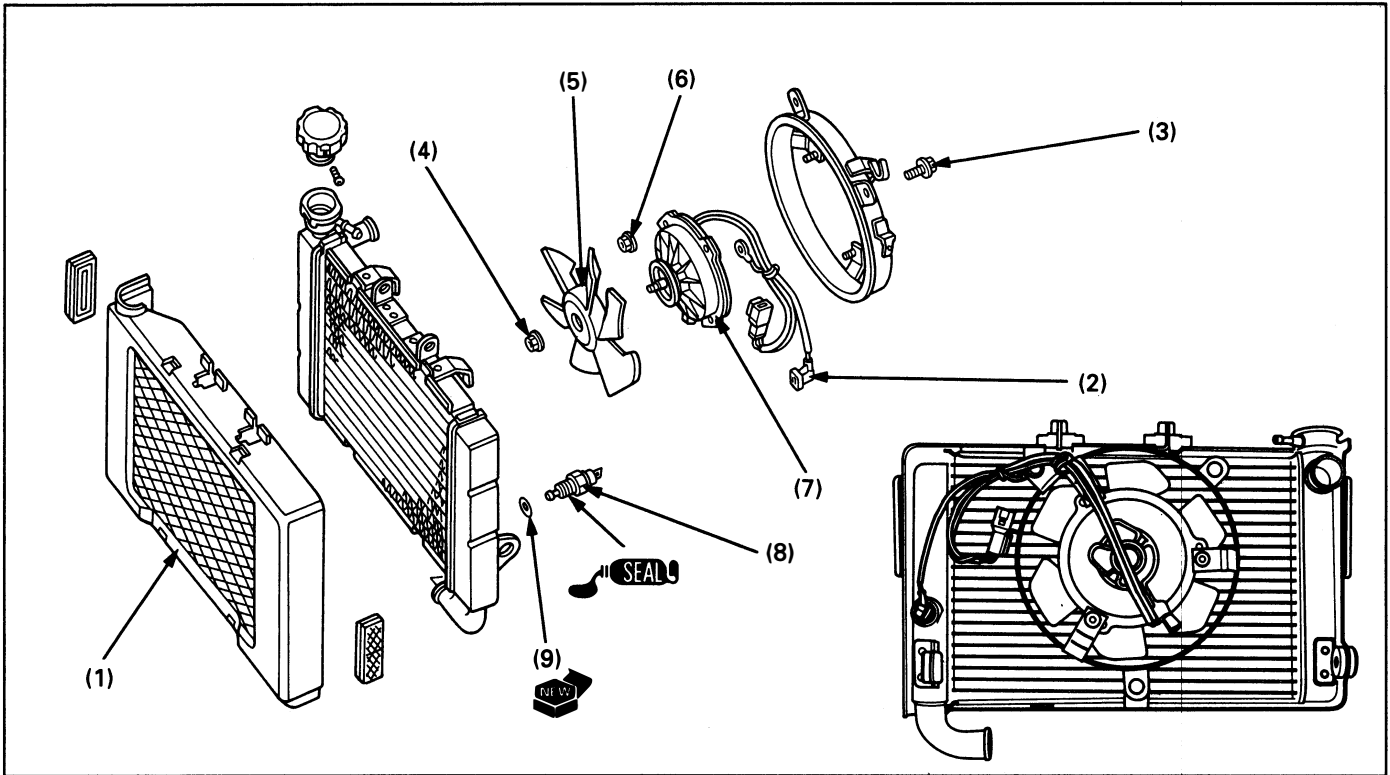

CAUTION

- Be careful not to damage the radiator core.

Requisite Service

- Radiator removal/installation (page 6-5)

Procedure		Q'ty	Remarks
(1)	Disassembly Order Radiator grill	1	Assembly is in the reverse order of disassembly. Release the two grooves from under of radiator, then remove the radiator grill.
(2)	Fan motor switch connector	1	
(3)	Cooling fan shroud bolt	3	At installation, install the ground eyelet joint with the bolt.
(4)	Cooling fan nut	1	At installation, align the cooling fan groove with the fan motor shaft.
(5)	Cooling fan	1	
(6)	Fan motor mounting nut	3	At installation, apply sealant to the switch threads.
(7)	Fan motor	1	
(8)	Fan motor switch	1	
(9)	O-ring	1	

Water Pump Removal/Installation

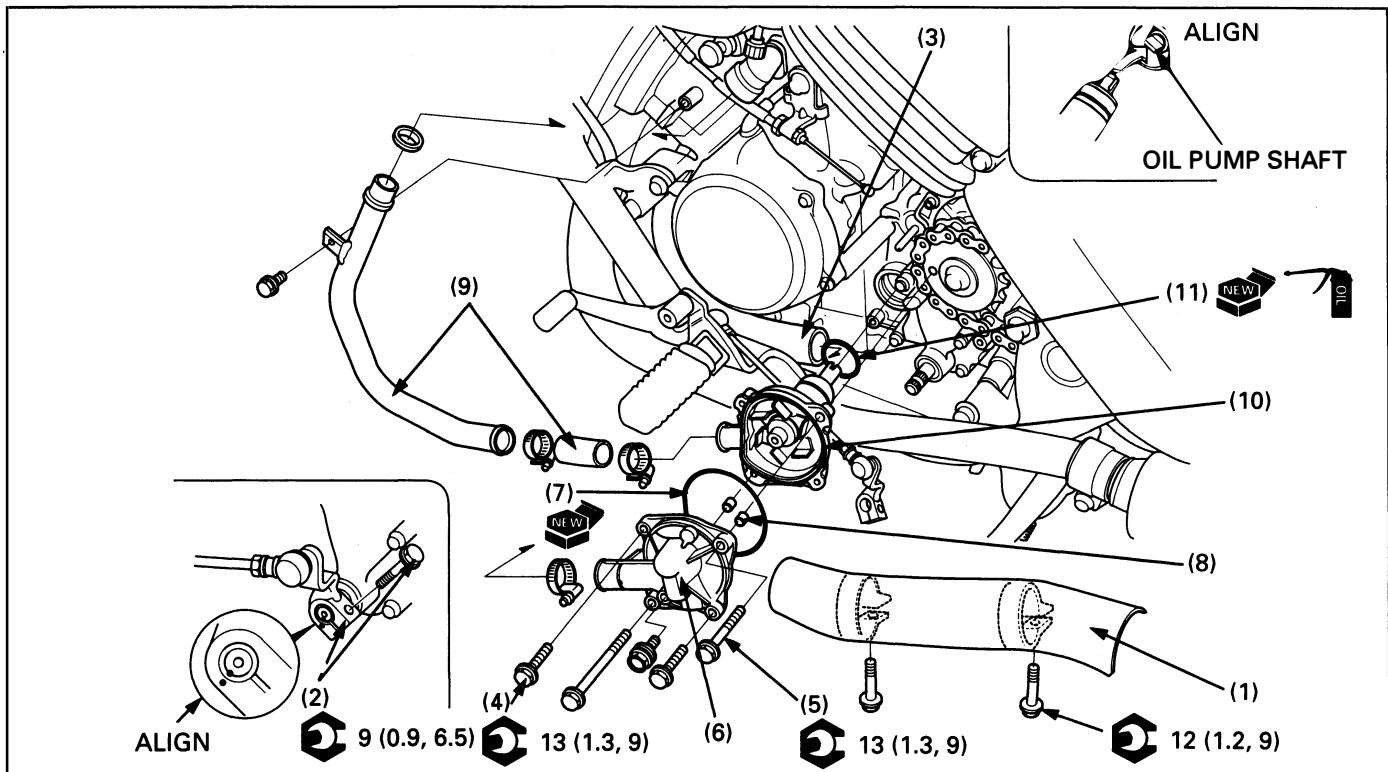

Requisite Service

- Coolant draining (page 6-3)
- Drive sprocket cover removal/installation (page 10-2)
- Coolant refill (Section 5 of the Common Service Manual)

Procedure	Q'ty	Remarks
Removal Order		Installation is in the reverse order of removal.
(1) Exhaust pipe protector	1	
(2) Gearshift link joint bolt/joint	1/1	
(3) Radiator lower hose	1	Loosen the clamp screw and disconnect the hose.
(4) Water pump cover bolt	2	
(5) Water pump mounting bolt	2	
(6) Water pump cover	1	
(7) O-ring	1	
(8) Dowel pin	2	
(9) Pump-to-engine hose	1	Loosen the hose clamp screw and disconnect it.
(10) Water pump body	1	At installation, align the cut-out of the water pump shaft with the oil pump shaft.
(11) O-ring	1	At installation, apply the engine oil to the new O-ring.

MEMO

7. Engine Removal/Installation

Service Information

7-1 Engine Removal/Installation

7-2

Service Information

- During removal and installation, support the motorcycle using a safety stand or hoist.

⚠ WARNING

- **Do not support the engine using the oil filter.**

- The following components can be serviced with the engine installed in the frame.
 - Oil pump (Section 4)
 - Carburetor (Section 5)
 - Water pump (Section 6)
 - Camshaft/cylinder head (Section 8)
 - Clutch (Section 9)
 - Gearshift linkage (Section 10)
 - Alternator (Section 15)
 - Pulse generator (Section 16)
 - Starter clutch (Section 17)
 - Starter motor (Section 17)
- The following components require engine removal for service.
 - Piston/connecting rod/cylinder (Section 11)
 - Crankshaft/transmission (Section 11)
 - Shift forks/shift drum (Section 11)

Engine Removal/Installation

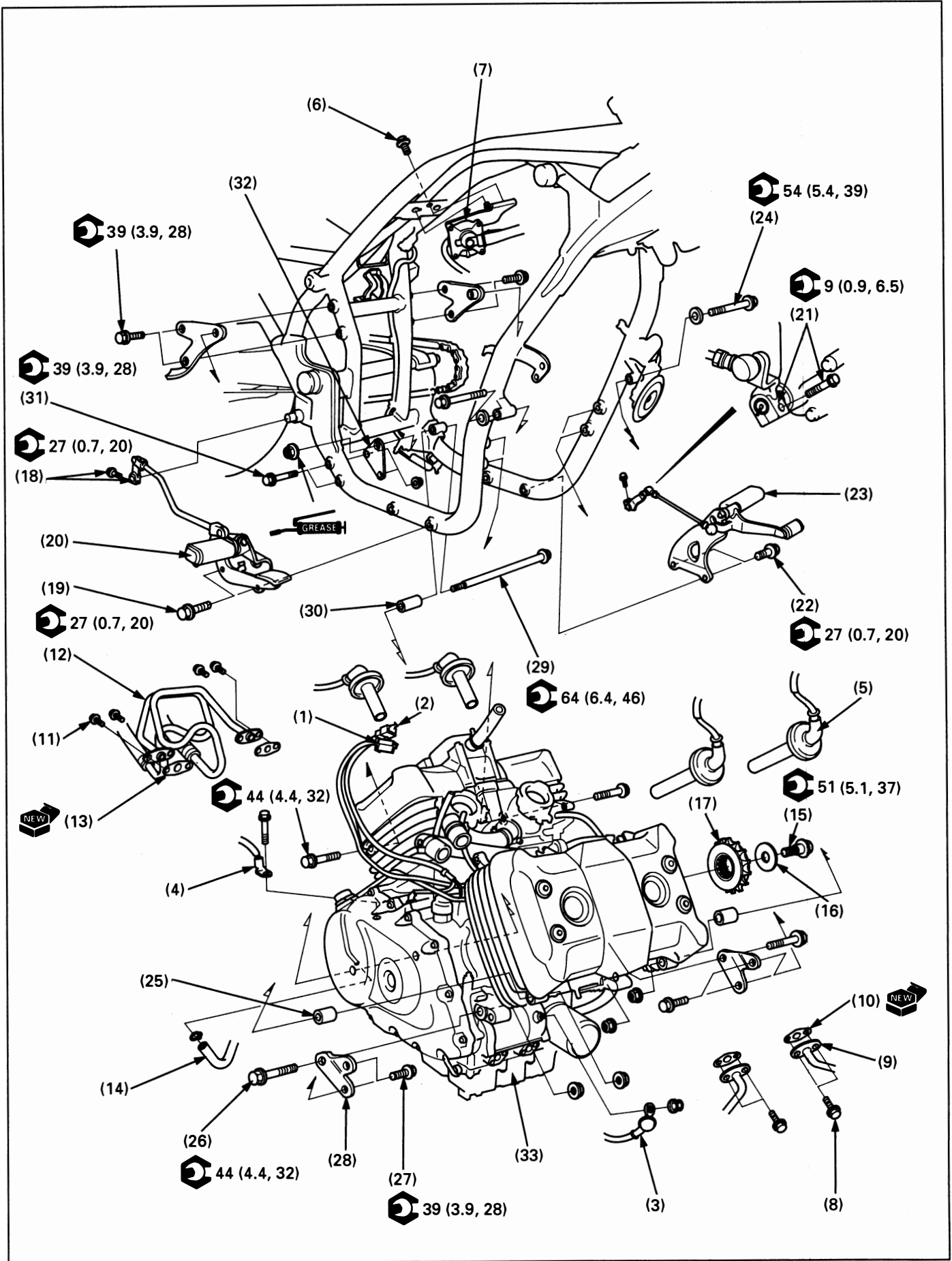

CAUTION

- Do not support the engine using the oil filter.

NOTE

- Support the motorcycle using safety stand or a hoist.
- A floor jack or other adjustable support is required to support and maneuver the engine. The jack height must be continually adjusted to relieve stress for ease of bolt removal.
- Turn the ignition switch OFF and disconnect the battery ground (-) terminal.
- Note the direction of the engine mounting bolts.
- Route the wire harnesses and tubes properly (page 1-20).

Requisite Service

- Fuel tank removal/installation (page 2-2)
- Carburetor removal/installation (page 5-4)
- Exhaust system removal/installation (page 2-4)
- Drive sprocket cover removal/installation (page 10-2)
- Radiator removal/installation (page 6-5)
- Right middle cover stay removal/installation

Procedure		Q'ty	Remarks
	Removal Order		Installation is in the reverse order of removal.
(1)	Alternator 3P connector	1	
(2)	Ignition pulse generator 3P connector	1	
(3)	Starter motor cable	1	
(4)	Ground cable eyelet	1	
(5)	Spark plug cap	4	
(6)	Auto fuel valve mounting bolt	2	
(7)	Auto fuel valve	1	
(8)	Front air suction pipe joint bolt	4	California type only.
(9)	Front air suction pipe	2	
(10)	Gasket	2	
(11)	Rear air suction pipe joint bolt	4	
(12)	Rear air suction pipe	2	
(13)	Gasket	2	
(14)	No. 4 vacuum tube	1	
(15)	Drive sprocket bolt	1	
(16)	Washer	1	
(17)	Drive sprocket	1	
(18)	Brake pedal linkage joint pinch bolt/joint	1/1	Align the punch marks.
(19)	Right foot peg bracket bolt	2	
(20)	Right foot peg bracket assembly	1	
(21)	Gearshift link joint bolt/joint	1/1	Align the punch marks.
(22)	Left foot peg bracket bolt	2	
(23)	Left foot peg bracket assembly	1	
(24)	Front cylinder head mounting bolt/nut/washer	2/2/2	Tightening procedure (page 7-4)
(25)	Collar (ø24 x 30 mm)	2	
(26)	Front engine mounting bolt/nut	2/2	
(27)	Front engine mounting bracket bolt	4	
(28)	Front engine mounting bracket	2	
(29)	Rear engine mounting bolt/nut	1/1	Apply clean grease to the nut threads and flange surface.
(30)	Collar (ø21 x 29.8 mm)	1	
(31)	Rear engine mounting bracket bolt/nut	2/2	
(32)	Rear engine mounting bracket	2	
(33)	Engine assembly	1	Move the engine assembly out of the frame to right. CAUTION • Carefully align mounting points with the jack to prevent damage to mounting bolt threads, wire harnesses and cable.

Engine Removal/Installation

Engine Mounting Bolt Tightening Procedure

Loosely install all engine mounting bolts, nuts and engine mounting bracket.

Tighten the 10 mm front cylinder head mounting bolts ① and ②.

Torque: 54 N-m (5.4 kg-m, 39 ft-lb)

Tighten the 8 mm engine mounting bracket bolts ③, ④, ⑤, ⑥ and ⑦.

Torque: 39 N-m (3.9 kg-m, 28 ft-lb)

Tighten the 10 mm engine mounting bolts ⑧, ⑨, ⑩ and ⑪.

Torque: 44 N-m (4.4 kg-m, 32 ft-lb)

Tighten the 12 mm engine mounting nut ⑫.

Torque: 64 N-m (6.4 kg-m, 46 ft-lb)

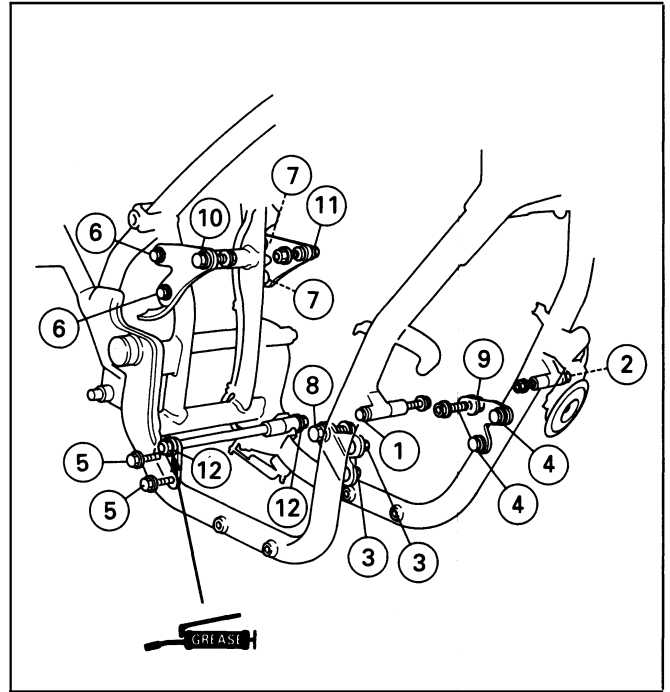

8. Cylinder Head/Valves

Service Information	8-1	Cylinder Head Removal/Installation	8-4
Troubleshooting	8-1	Cylinder Head Disassembly/Assembly	8-6
Camshaft Removal	8-2	Camshaft Installation	8-8

Service Information

- Front and rear cylinder head service can be done with the engine in the frame.
- Camshaft lubricating oil is fed through oil passages in the cylinder head. Clean the oil passages before assembling the cylinder head. Fill the cylinder head oil pockets with the clean engine oil of the proper type and viscosity.
- Clean all disassembled parts with clean solvent and dry them by blowing them off with compressed air before inspection.
- When disassembling, mark and store the disassembled parts to ensure that they are reinstalled in their proper locations.
- The cylinder numbering is given below:

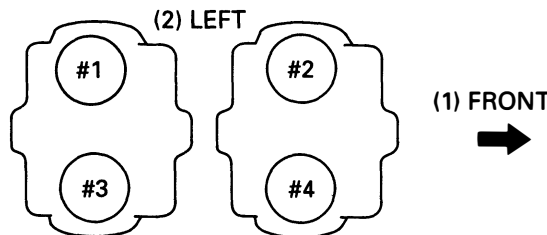

Troubleshooting

- Engine top-end problems usually affect engine performance. These can be diagnosed by a compression or leak down test, or by tracing noises to the top-end with a sounding rod or stethoscope.
- If performance is poor at low speeds, check for white smoke in the crankcase breather tube. If there is smoke in the tube, check for a seized piston ring.

Compression Too Low, Hard Starting Or Poor Performance At Low Speed

- Valves
 - Incorrect valve adjustment
 - Burned or bent valves
 - Incorrect valve timing
 - Broken valve spring
 - Uneven valve seating
- Cylinder head
 - Leaking or damaged head gasket
 - Warped or cracked cylinder head
- Cylinder/piston
 - Worn, stuck or broken piston ring
 - Worn or damage cylinder and piston

Compression Too High, Overheating Or Knocking

- Excessive carbon build-up in cylinder head or on top of piston

Excessive Smoke

- Cylinder head
 - Worn valve stem or valve guide
 - Damaged stem seal
- Cylinder; piston
 - Worn cylinder, piston, or piston rings
 - Improper installation of piston rings
 - Scored or scratched piston or cylinder wall

Excessive Noise

- Cylinder head
 - Incorrect valve adjustment
 - Sticking valve or broken valve spring
 - Damaged or worn camshaft
 - Loose or worn cam chain
 - Worn or damaged cam chain
 - Worn or damaged cam chain tensioner
 - Worn cam sprocket teeth
- Cylinder, piston
 - Worn cylinder and piston
 - Worn piston pin and piston pin hole

Rough Idle

- Low cylinder compression

Piston Knocking

- Worn cylinder, piston or piston ring
- Worn piston pin and piston pin hole
- Worn connecting rod small end

Excessive Smoke

- Worn, stuck, or broken piston ring

Abnormal Noise

- Worn cylinder and piston

Camshaft Removal

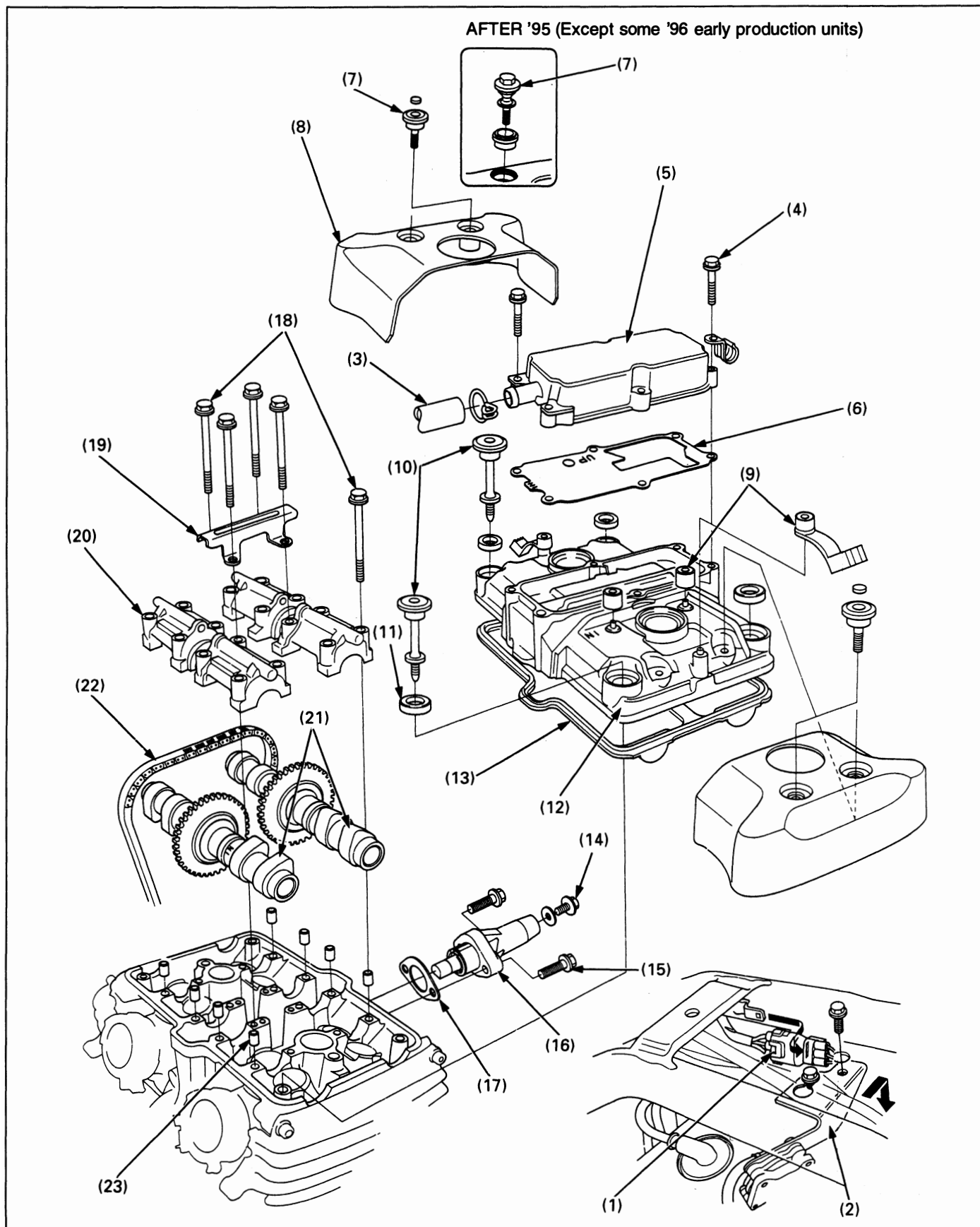

NOTE

- Service the front cylinder camshaft using the same procedure as the rear cylinder.
- Remove the cam chain tensioner before removing the camshaft.
- The "T1" timing marks on the starter clutch are for rear cylinder head service.
- The "T2" timing marks on the starter clutch are for front cylinder head service.
- Be careful not to drop parts into the engine opening.

Requisite Service

Rear cylinder:

- Fuel tank removal/installation (page 2-2)
- Spark plug cap removal/installation
- Muffler removal/installation (page 2-4)

Front cylinder:

- Fuel tank removal/installation (page 2-2)
- Radiator removal/installation (page 6-5)
- Spark plug cap removal/installation
- Front PAIR control valve removal/installation (California type only page 5-18)

Procedure		Q'ty	Remarks
	Removal Order		
(1)	Side stand switch connector	1	Rear cylinder head only.
(2)	Auto fuel valve	1	
(3)	Breather tube	1	
(4)	Breather case bolt	6	
(5)	Breather case	1	
(6)	Breather plate	1	
(7)	Head cover protector bolt	4	
(8)	Head cover protector	2	
(9)	Head cover protector rubber	6	
(10)	Rear cylinder head cover bolt	4	
(11)	Washer	4	
(12)	Rear cylinder head cover	1	
(13)	Head cover gasket	1	
(14)	Cam chain tensioner sealing bolt/washer	1/1	
(15)	Cam chain tensioner mounting bolt	2	
(16)	Cam chain tensioner	1	
(17)	Gasket	1	
(18)	Camshaft holder bolt	16	
			• Before loosening, align the "T1" (front cylinder: "T2") mark on the starter clutch with the index mark on the right crankcase cover, and make sure the No. 1 piston (front cylinder: No. 4 piston) is on compression stroke. If it is not on the compression stroke, turn the crankshaft clockwise 360° and align the marks again.
			• Loosen the holder bolts in a gradual, crisscross pattern.
(19)	Cam chain guide	1	
(20)	Camshaft holder	4	
(21)	Camshaft IN/EX	2	
(22)	Cam chain	1	Derail the cam chain from the sprocket and attach a piece of mechanic's wire to it to prevent it from dropping into the crankcase.
(23)	Dowel pin	8	

Cylinder Head Removal/Installation

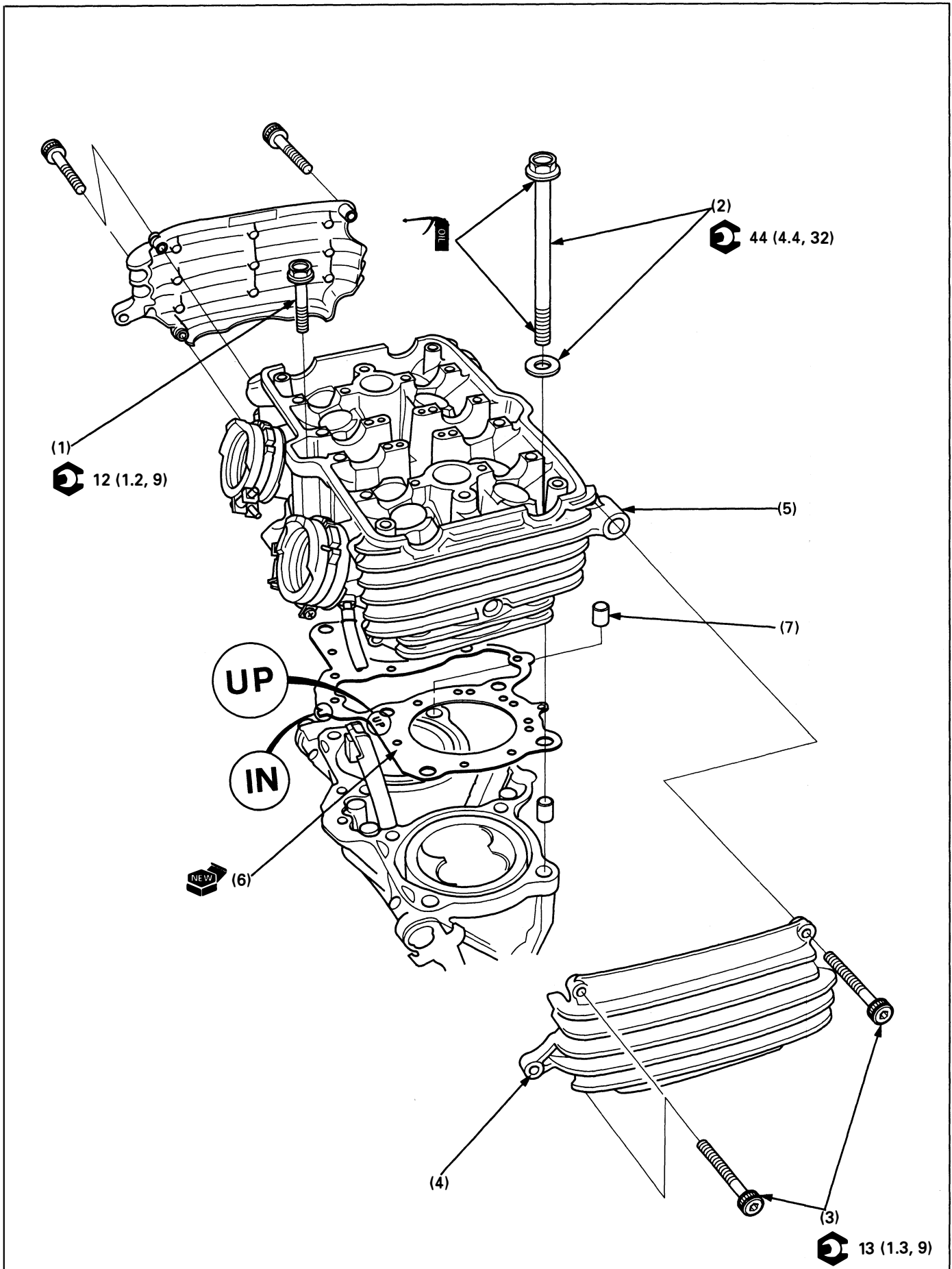

NOTE

- Service the front cylinder head using the same procedure as the rear cylinder.
- Apply engine oil to the seat and threads of the cylinder head bolts.
- Before removing the engine mounting bolts from the cylinder head, support the engine with a jack or other support to avoid over-loading the other bolts.

Requisite Service

Rear cylinder:

- Camshaft removal/installation (page 8-2, 8)
- Carburetor removal/installation (page 5-4)
- Thermostat removal/installation (page 6-4)
- Air suction pipe removal/installation (California type only)

Front cylinder:

- Camshaft removal/installation (page 8-2, 8)
- Muffler removal/installation (page 2-4)
- Air suction pipe removal/installation (California type only)
- Carburetor removal/installation (page 5-4)
- Thermostat removal/installation (page 6-4)

	Procedure	Q'ty	Remarks
	Removal Order		
(1)	Cylinder head 6 mm bolt	2	<ul style="list-style-type: none"> • Loosen the fasteners in a criss-cross pattern in 2 or 3 steps. • Refer to page 8-17 for installation.
(2)	Cylinder head 9 mm bolt/washer	8/8	
(3)	Cylinder head protector bolt	6	Disassembly (page 8-6) Install with the "UP" mark facing up and "IN" mark facing intake side.
(4)	Cylinder head protector	2	
(5)	Cylinder head	1	
(6)	Cylinder head gasket	1	
(7)	Dowel pin	2	

Cylinder Head Disassembly/Assembly

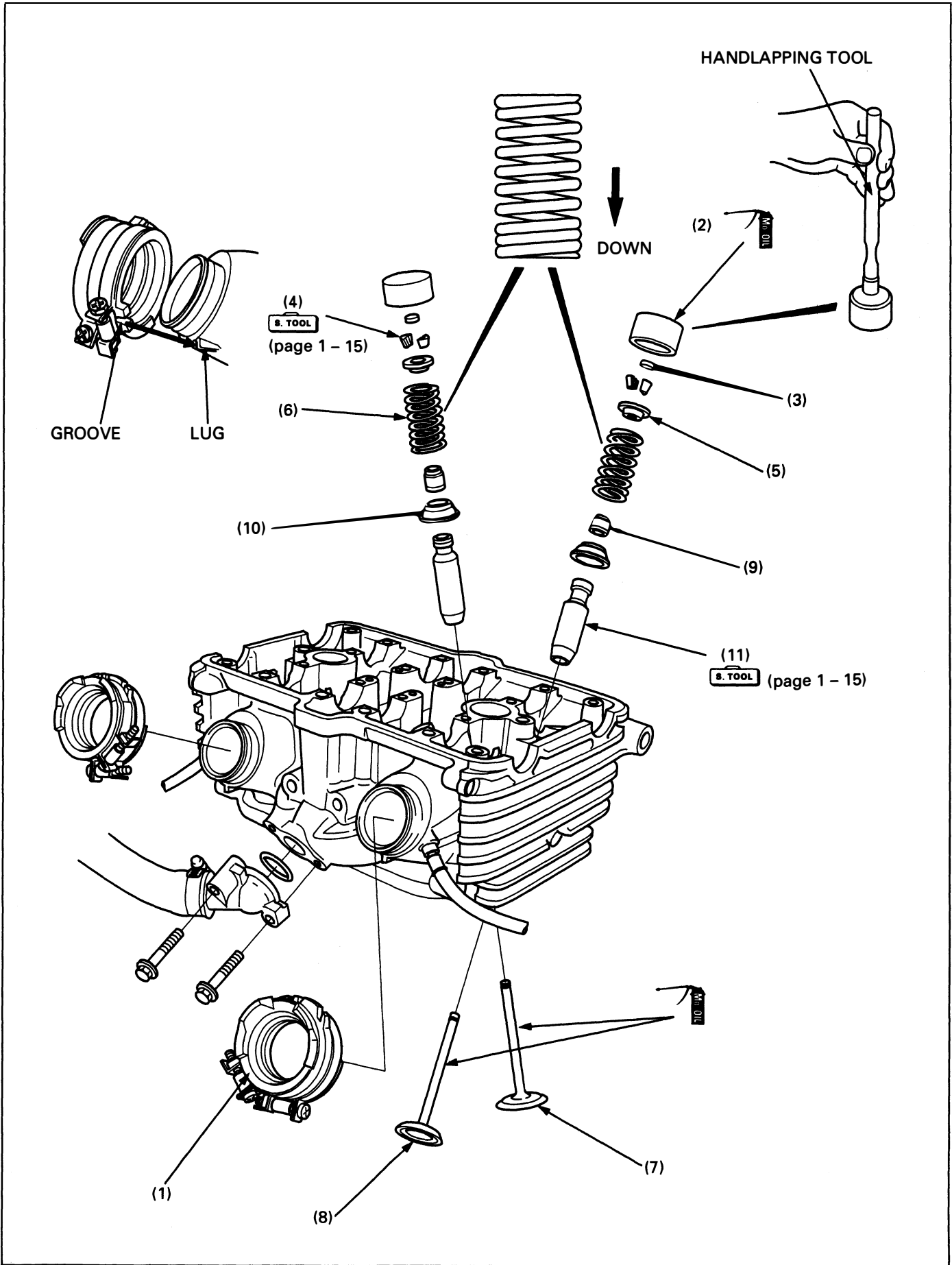

NOTE

- Service the front cylinder head using the same procedure as the rear cylinder head.
- Mark all parts during disassembly so they can be placed back their original position.
- Remove carbon deposits from the combustion chamber and clean off the head gasket surface, before assembly.
 - Avoid damaging the gasket surface.
 - Gaskets will come off easier soaked in solvent.
- Valve guide replacement see Section 9 of the Common Service Manual.

Requisite Service

- Cylinder head removal/installation (page 8-4)

Procedure		Q'ty	Remarks
(1)	Disassembly Order Insulator	2	Assembly is in the reverse order of disassembly NOTE • Align the groove of the insulator with the lug of the cylinder head.
(2)	Valve lifter	8	NOTE • Remove using a handlapping tool. Do not damage the cylinder head-lifter sliding surface.
(3)	Valve shim	8	NOTE • Removal/Installation (page 8-17) • To prevent loss of tension, do not compress the valve spring more than necessary.
(4)	Valve spring cotter	16	
(5)	Valve spring retainer	8	At installation, install the valve springs with the tightly wound coils end facing the combustion chamber.
(6)	Valve spring	8	
(7)	Intake valve	4	NOTE • Before installation, lubricate each valve stem with molybdenum disulfide oil.
(8)	Exhaust valve	4	
(9)	Stem seal	8	Valve guide projection (page 1-7)
(10)	Valve spring seat	8	
(11)	Valve guide	8	

Camshaft Installation

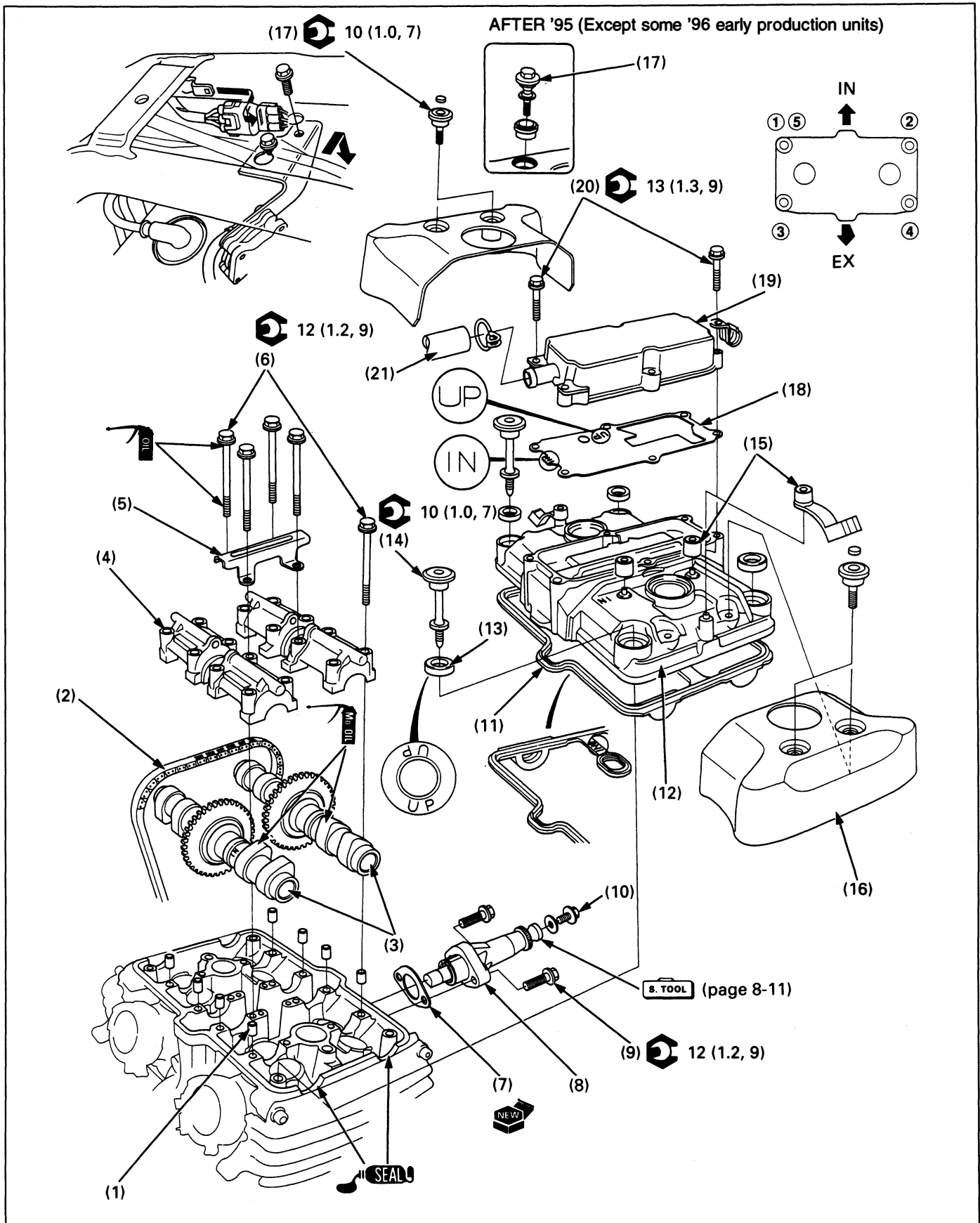

NOTE

- Service the front cylinder camshaft using the same procedure as the rear cylinder.
- Each camshaft has an identification mark. Use these marks during installation to ensure that the camshafts are properly located.
 FRONT INTAKE: "FR", "IN" REAR INTAKE: "RR", "IN"
 FRONT EXHAUST: "FR", "EX" REAR EXHAUST: "RR", "EX"
- Be careful not to drop any parts into the engine opening.

Requisite Service

Rear cylinder:

- Fuel tank removal/installation (page 2-2)
- Spark plug cap removal/installation
- Muffler removal/installation (page 2-4)

Front cylinder:

- Fuel tank removal/installation (page 2-2)
- Spark plug cap removal/installation
- Radiator removal/installation (page 6-4)
- Front PAIR control valve removal/installation (California type only page 5-18)

Procedure		Q'ty	Remarks
Installation Order			
(1)	Dowel pin	8	Refer to page 8-10 for installation
(2)	Cam chain	1	
(3)	Camshaft IN/EX	2	
(4)	Camshaft holder	4	
(5)	Cam chain guide	1	
(6)	Camshaft holder bolt	16	
(7)	Gasket	1	
(8)	Cam chain tensioner	1	
(9)	Cam chain tensioner mounting bolt	2	
(10)	Cam chain tensioner sealing bolt/washer	1/1	
(11)	Head cover gasket	1	NOTE • Apply Honda Bond A or equivalent to the head cover and install the gasket with "IN" mark facing the intake side.
(12)	Rear cylinder head cover	1	Install with the "UP" mark facing up. • Tighten the bolts in the order shown. • Tighten the ① bolt again after tightening the other bolts.
(13)	Washer	4	
(14)	Rear cylinder head cover bolt	4	
(15)	Head cover protector rubber	6	
(16)	Head cover protector	2	• Install with the "UP" mark facing up and "IN" mark facing the intake side. • Rear cylinder head only.
(17)	Head cover protector bolt	4	
(18)	Breather plate	1	
(19)	Breather case	1	
(20)	Breather case bolt	6	
(21)	Breather tube	1	
(22)	Side stand switch connector	1	
(23)	Auto fuel valve	1	

Camshaft Installation

Each camshaft has an identification mark. Install the camshafts in the correct positions, noting the identification marks below:

- Front Intake: "FR", "IN"
- Front Exhaust: "FR", "EX"
- Rear Intake: "RR", "IN"
- Rear Exhaust: "RR", "EX"

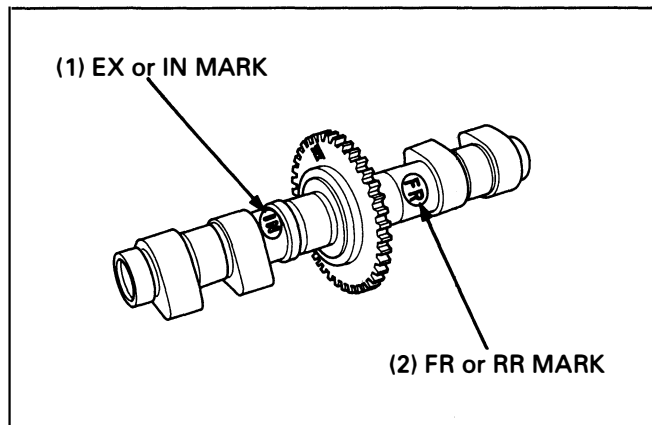

When Both Front And Rear Cylinder Camshaft Were Removed

- **Rear cylinder**
Align the "T1" mark on the starter clutch with the index mark on the right crankcase cover.

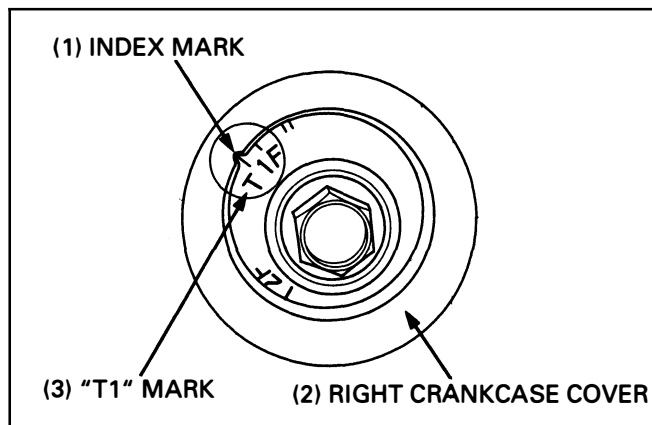

Install the camshaft holder dowel pins onto the rear cylinder head.
Lubricate the camshaft journal surface of the cylinder head, camshaft holder and cam lobes with molybdenum disulfide oil.

Install the camshafts onto the rear cylinder head.
The "R-EX" timing mark on the rear exhaust camshaft sprocket is level with the cylinder head upper edge as shown.

Check that the "R-IN" timing mark on the rear intake camshaft sprocket is level with the cylinder head upper edge as shown.

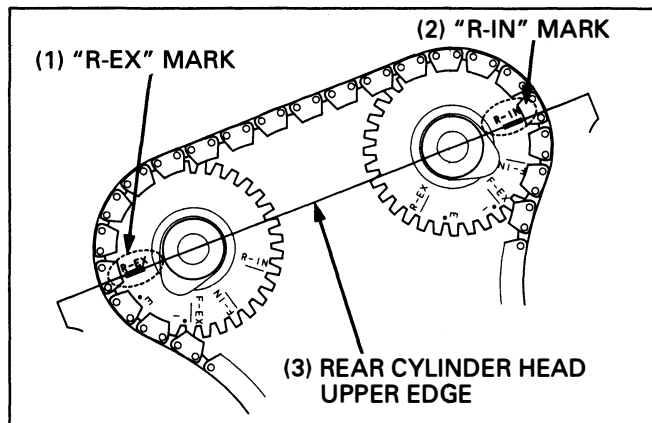

Install the camshaft holders in the correct positions, checking the identification marks on the holders and cylinder head.
Install the cam chain guide.

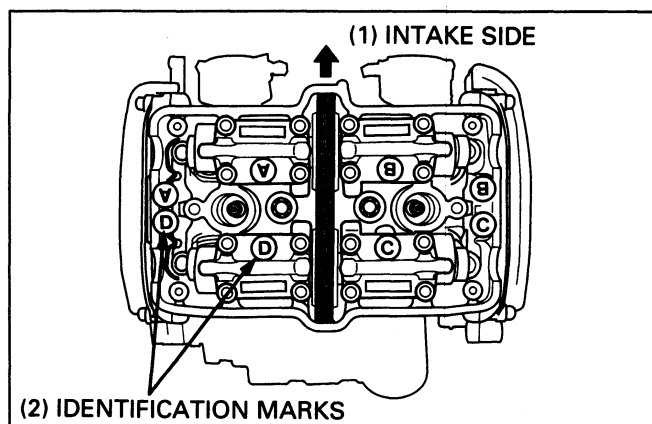

• **Rear cylinder (cont'd)**

Torque the cam shaft holder bolts in the sequence shown.

Torque: 12 N·m (1.2 kg·m, 9 ft·lb)

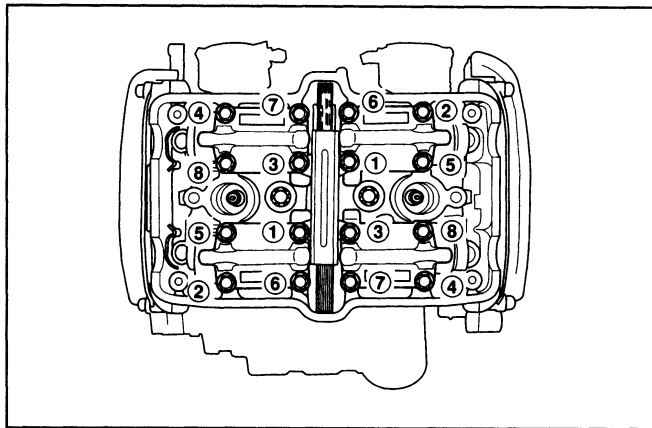

Turn the cam chain tensioner shaft fully in (clockwise) secure it using special tool.

S. TOOL

Tensioner stopper

**07NMG - MY90100
(Not available in U.S.A.)**

Cam chain tensioner stopper tool can easily be made from a thin (1 mm thickness) piece of steel.

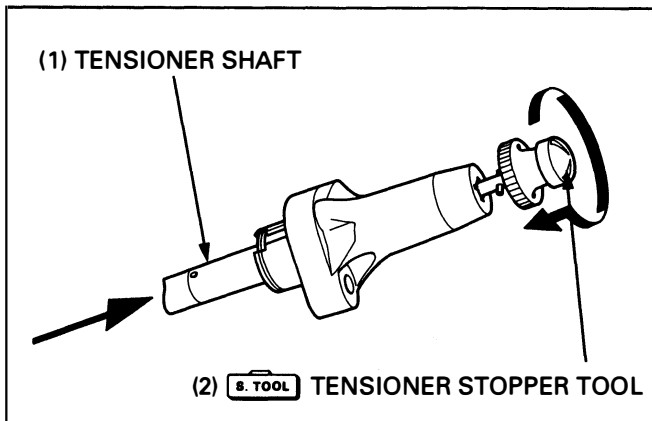
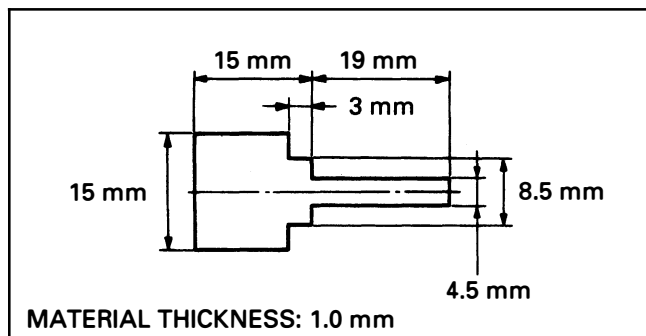

Install the new gasket and cam chain tensioner to rear cylinder head.

Torque the cam chain tensioner mounting bolts.

Torque: 12 N·m (1.2 kg·m, 9 ft·lb)

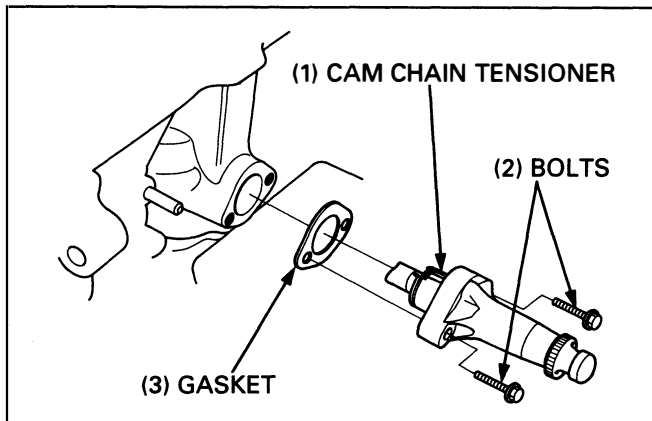

Remove the cam chain tensioner stopper tool.

Install the cam chain tensioner sealing bolt and washer.

Make sure the timing marks on the camshaft sprockets are level with the cylinder head upper edge.

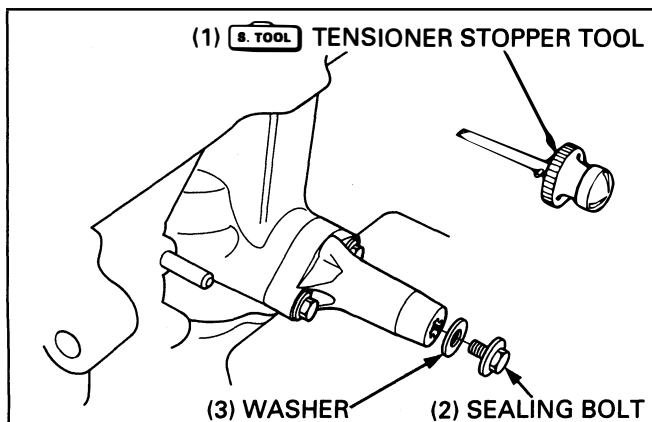

Cylinder Head/Valves

- **Front cylinder**

Rotate the crankshaft clockwise 90° to align the "T2" mark with the index mark on the right crankcase cover.

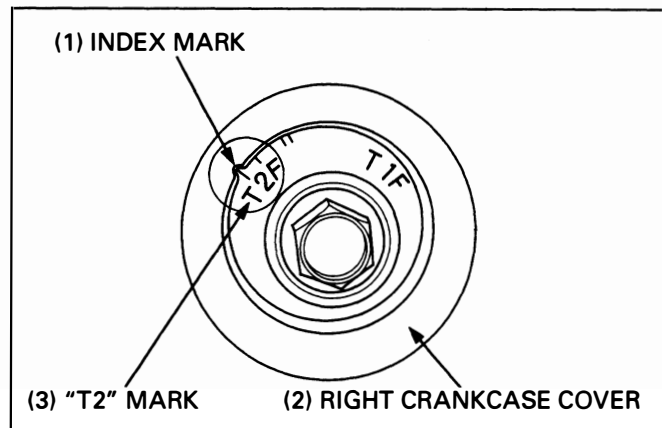

Install the camshaft holder dowel pins onto the front cylinder head.

Lubricate the camshaft journal surface, camshaft holder and cam lobes with molybdenum disulfide oil.

Install the camshafts onto the front cylinder head. Check that the "F-EX" timing mark on the front exhaust camshaft sprocket is level with the cylinder head upper edge as shown.

Check that the "F-IN" timing mark on the front intake camshaft sprocket is level with the cylinder head upper edge as shown.

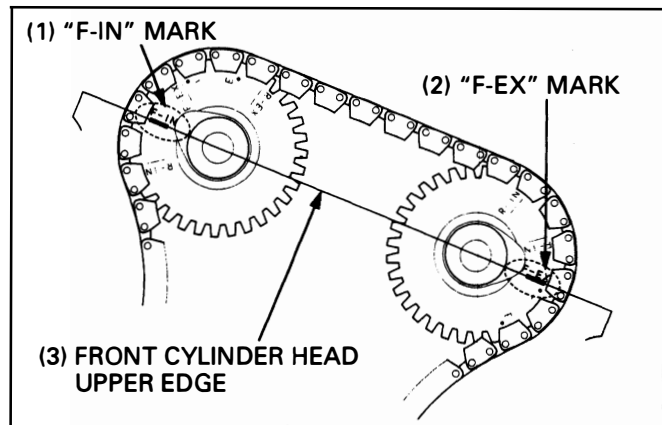

Install the camshaft holders in the correct positions, checking the identification marks on the holders and cylinder head.

Install the cam chain guide.

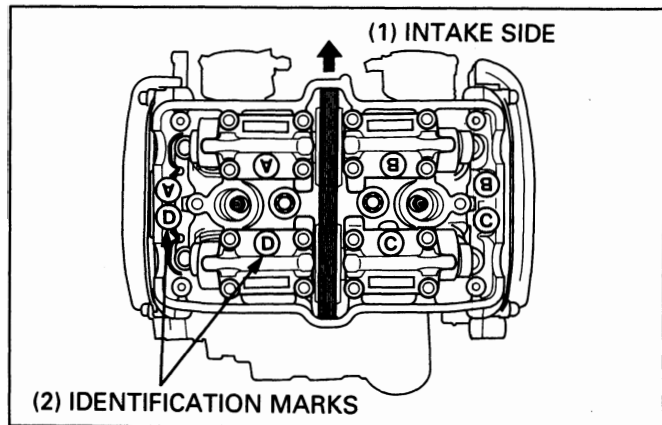

Torque the cam shaft holder bolts in the sequence shown.

Torque: 12 N-m (1.2 kg-m, 9 ft-lb)

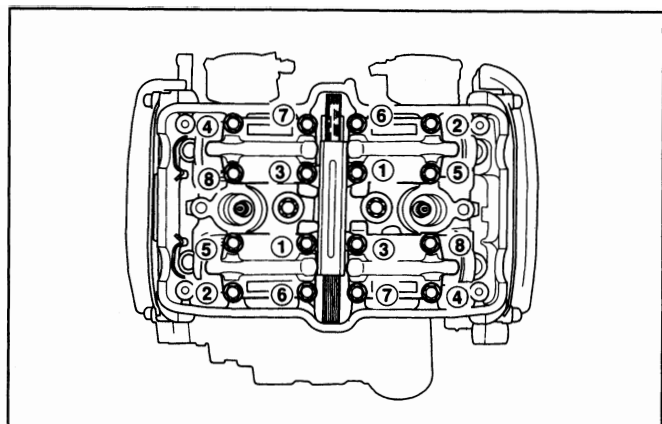

• **Front cylinder (cont'd)**

Turn the cam chain tensioner shaft completely in (clockwise) and secure it using the stopper tool. This tool can easily be made from a thin (1 mm thickness) piece of steel.

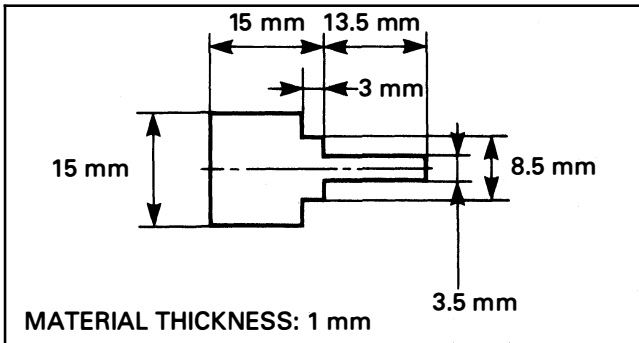

Install a new gasket and cam chain tensioner.

Torque the cam chain tensioner mounting bolts.

Torque: 12 N·m (1.2 kg·m, 9 ft·lb)

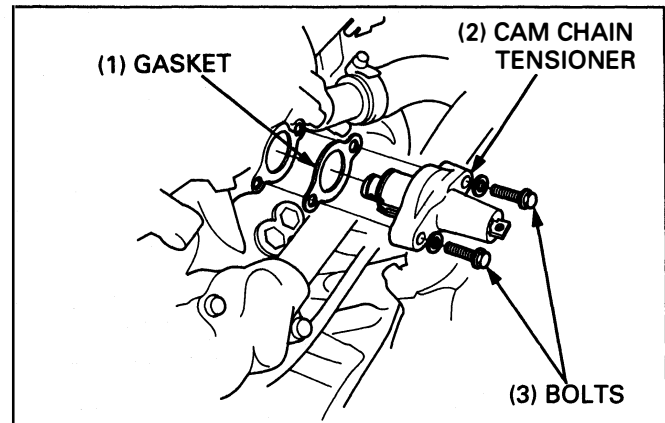
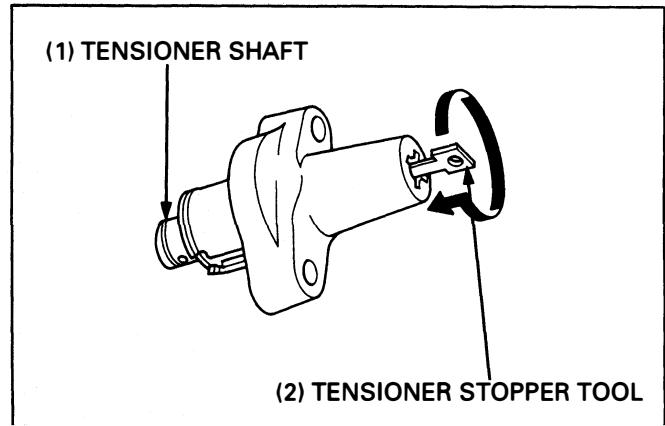

Remove the cam chain tensioner stopper tool.

Install the cam chain tensioner sealing bolt and washer.

Make sure the timing marks on the camshaft sprockets are level with the cylinder head upper edge.

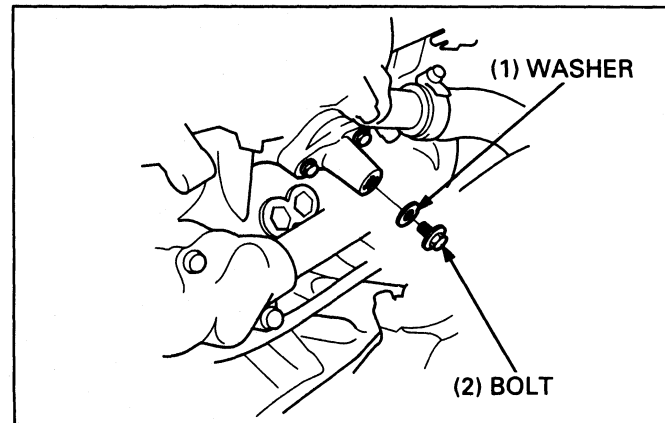

When The Rear Cylinder Camshaft Only Was Removed

Align the "T2" mark with the index mark on the right crankcase cover. Remove the front cylinder head cover (page 8-2).

Make sure #2 cylinder is TDC on the compression stroke.

If it is not, turn the crankshaft clockwise 360° and make sure "T2" mark aligns with the index mark on the right crankcase cover.

Rotate the crankshaft clockwise 270° to align the "T1" mark with the index mark on the right crankcase cover.

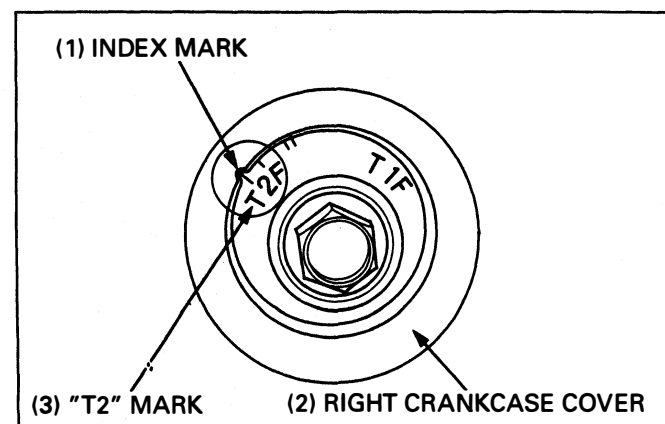

Cylinder Head/Valves

Install the camshaft holder dowel pins in the rear cylinder head.

Lubricate the camshaft journal surfaces, camshaft holder and cam lobes with molybdenum disulfide oil.

Install the camshafts onto the rear cylinder head.

Check that the "R-EX" timing mark on the rear exhaust camshaft sprocket is level with the cylinder head upper edge as shown.

Check that the "R-IN" timing mark on the rear intake camshaft sprocket is level with the cylinder head upper edge as shown.

Install the camshaft holders in the correct positions, checking the identification marks on the holders and cylinder head.

Install the cam chain guide.

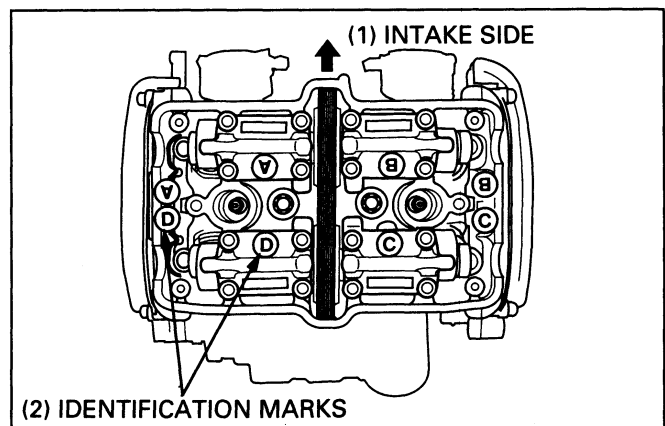
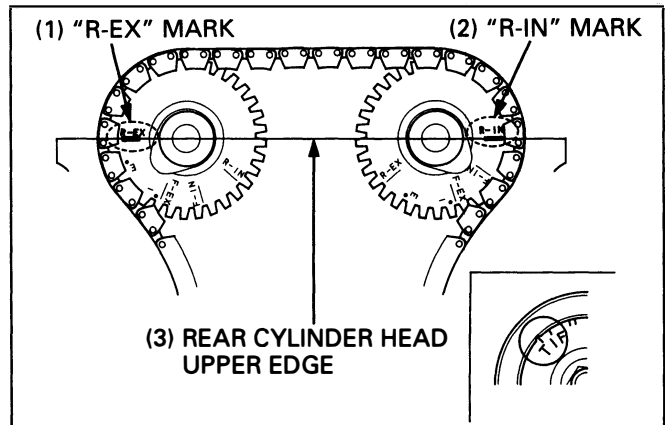

Torque the cam shaft holder bolts in the sequence shown.

Torque: 12 N-m (1.2 kg-m, 9 ft-lb)

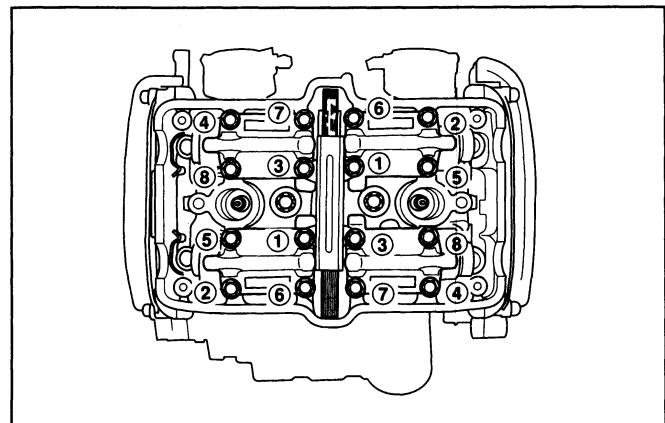

Turn the cam chain tensioner shaft completely in (clockwise) and secure it using the special tool.

S. TOOL

Tensioner stopper

07NMG - MY90100
(Not available in U.S.A.)

Cam chain tensioner stopper tool can easily be made from a thin (1 mm thickness) piece of steel.

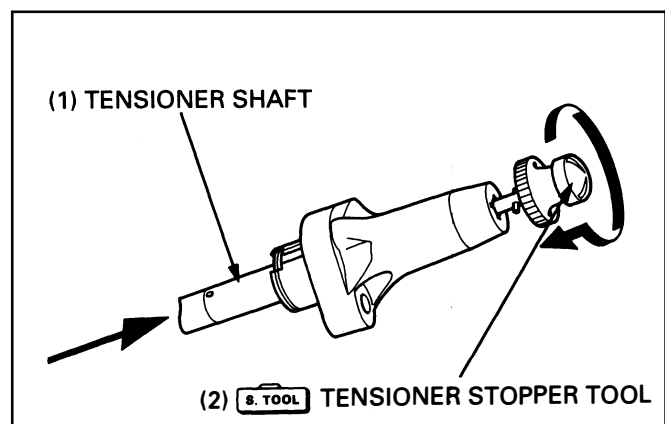
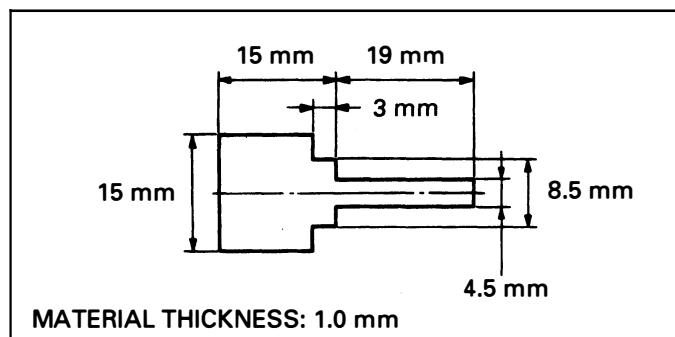

Install a new gasket and cam chain tensioner.

Torque the cam chain tensioner mounting bolts.

Torque: 12 N·m (1.2 kg·m, 9 ft·lb)

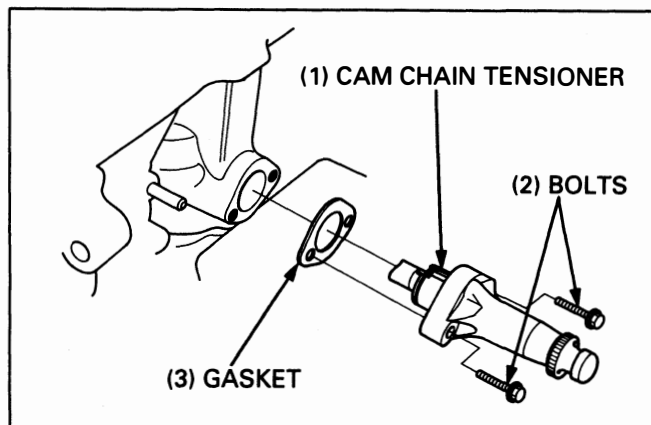

Remove the cam chain tensioner stopper tool.

Install the cam chain tensioner sealing bolt and washer.

Make sure the timing marks on the camshaft sprockets are level with the cylinder head upper edge.

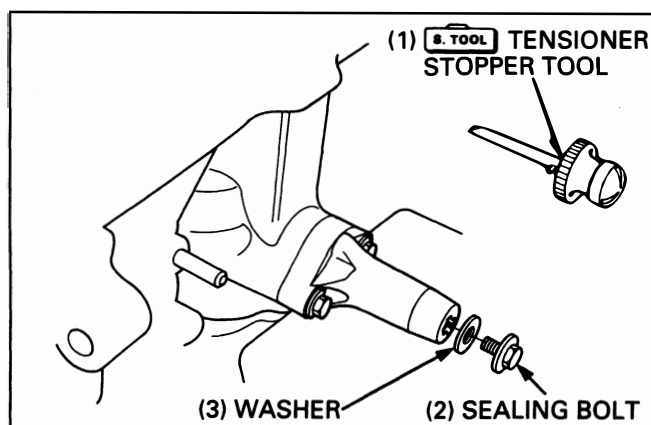

When The Front Cylinder Camshaft Only Was Removed

Align the "T1" mark with the index mark on the right crankcase cover.

Remove the rear cylinder head cover (page 8-2).

Make sure #1 cylinder is TDC on the compression stroke.

If it is not, turn the crankshaft clockwise 360° and make sure "T1" mark aligns with the index mark on the right crankcase cover.

Rotate the crankshaft clockwise 90° to align the "T2" mark with the index mark on the right crankcase cover.

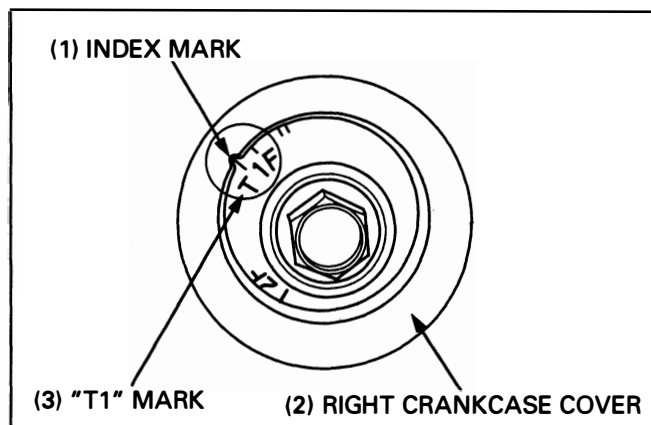

Install the camshaft holder dowel pins onto the front cylinder head.

Lubricate the camshaft journal surface, camshaft holder and cam lobes with molybdenum disulfide oil.

Install the camshafts onto the front cylinder head. Check that the "F-EX" timing mark on the front exhaust camshaft sprocket is level with the cylinder head upper edge as shown.

Check that the "F-IN" timing mark on the front intake camshaft sprocket is level with the cylinder head upper edge as shown.

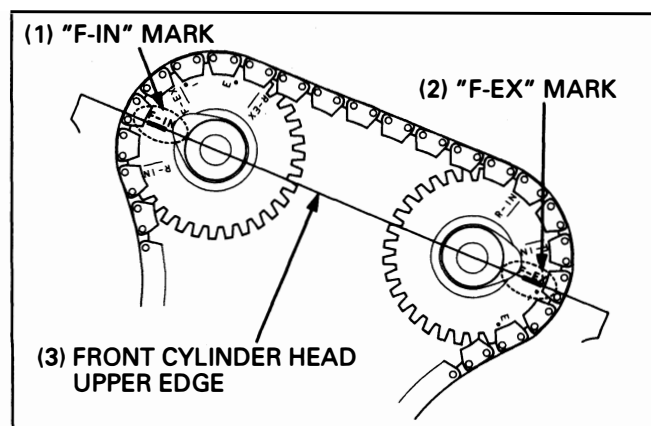

Cylinder Head/Valves

Install the camshaft holders in the correct positions, checking the identification marks on the holders and cylinder head.

Install the cam chain guide.

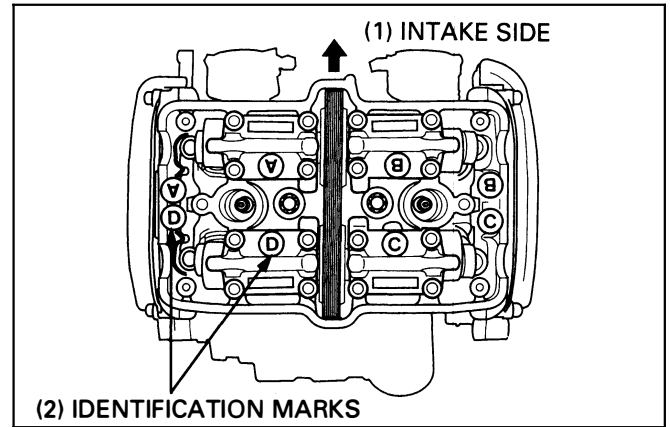

Torque the cam shaft holder bolts in the sequence as shown.

Torque: 12 N·m (1.2 kg·m, 9 ft·lb)

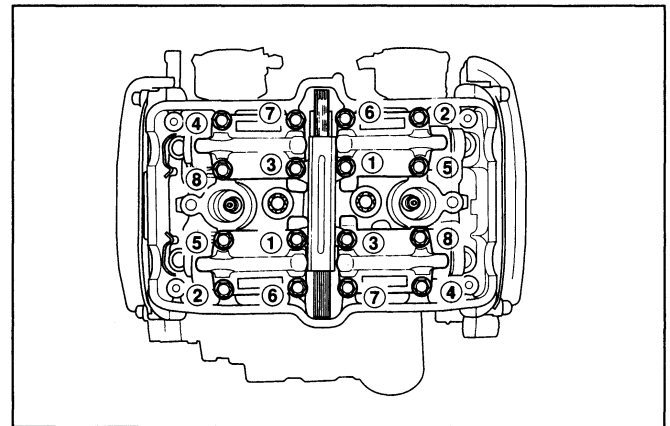

Turn the cam chain tensioner shaft completely in (clock-wise) and secure it using the stopper tool. This tool can easily be made from a thin (1 mm thickness) piece of steel.

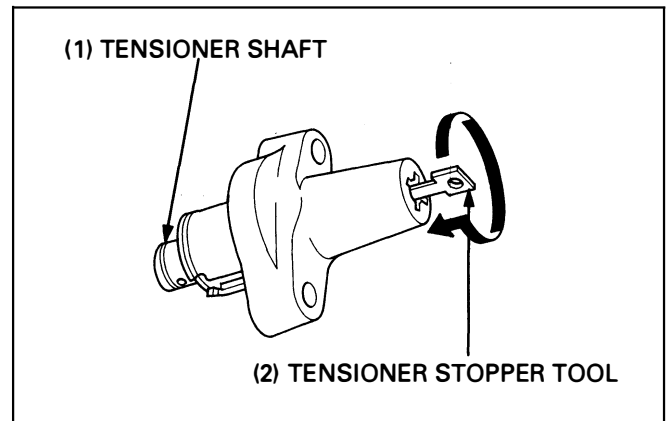
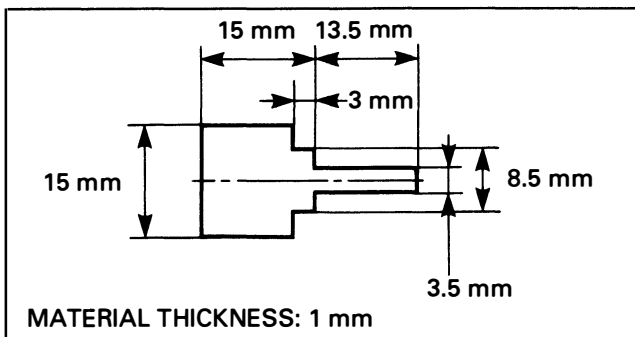

Install a new gasket and cam chain tensioner.

Torque the cam chain tensioner mounting bolts.

Torque: 12 N·m (1.2 kg·m, 9 ft·lb)

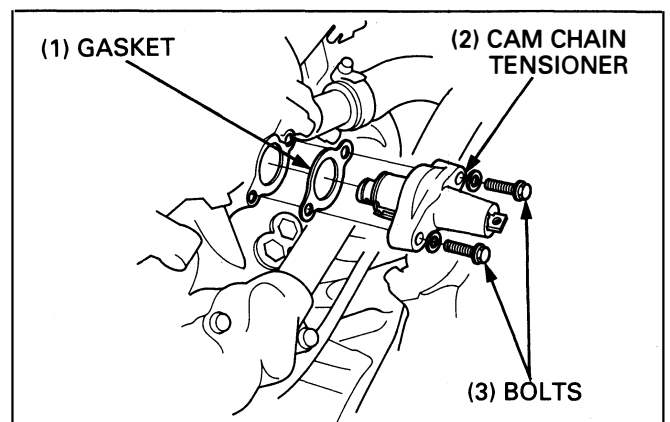

Remove the cam chain tensioner stopper tool.

Install the cam chain tensioner sealing bolt and washer.

Make sure the timing marks on the camshaft sprockets are level with the cylinder head upper edge.

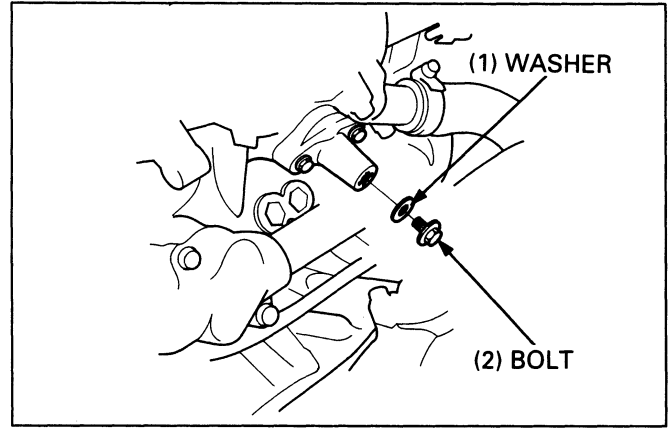

Valve Cotter Removal/Installation

Remove the valve lifters and shims.

NOTE

- Mark the positions of all valve lifters and shims to ensure correct reassembly.
- It is easy to remove the valve lifter with a valve lapping tool or magnet.
- Remove the shims with tweezers or a magnet.

Install the tappet hole protector into the valve lifter bore.

S. TOOL

Tappet hole protector

07HMG – MR70002

Not available in U.S.A

Install the valve spring compressor onto the valve and compress the valve spring.

CAUTION:

- To prevent loss of tension, do not compress the valve springs more than necessary.

Remove the valve cotters.

S. TOOL

Valve spring compressor

07757 – 0010000

Valve spring compressor attachment

07959 – KM30101

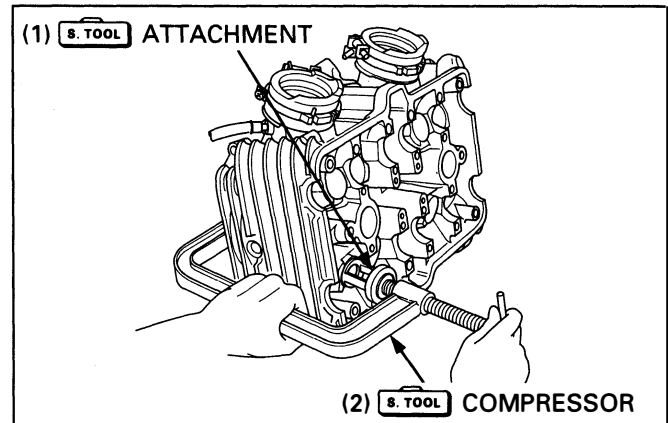
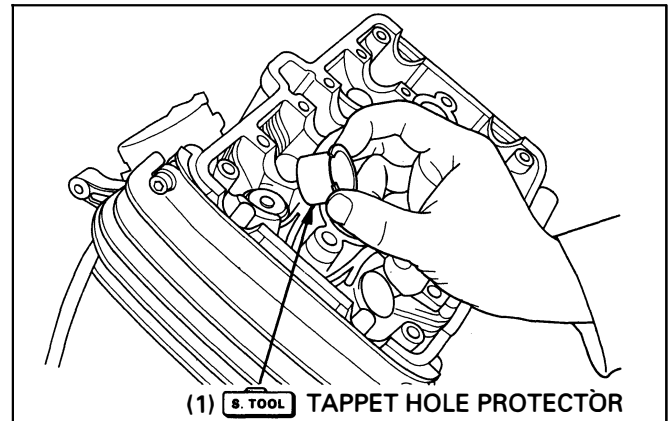

Installation is in the reverse order of removal.

Cylinder Head Bolt Installation

Apply engine oil to the seating surface and threads, then tighten the cylinder head mounting bolts gradually in a crisscross pattern in the order as shown.

Torque:

6 mm bolt: 12 N·m (1.2 kg-m, 9 ft-lb)

9 mm bolt: 44 N·m (4.4 kg-m, 32 ft-lb)

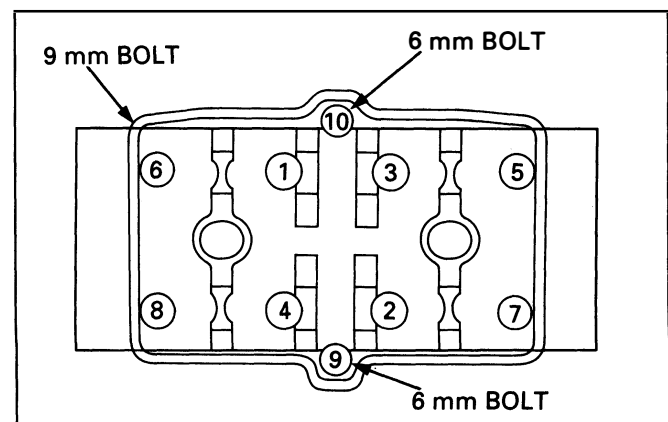

MEMO

9. Clutch System

Service Information	9-1	Clutch Removal	9-4
Troubleshooting	9-1	Clutch Installation	9-6
Right Crankcase Cover Removal/ Installation	9-2		

Service Information

- Clutch maintenance can be done with the engine in the frame.
- Transmission oil viscosity and level have an effect on clutch disengagement. When the clutch does not disengage or the vehicle creeps with clutch disengaged, inspect the transmission oil level before servicing the clutch system.

Troubleshooting

Clutch Slips When Accelerating

- Incorrect clutch adjustment
- Worn clutch discs
- Weak clutch springs
- Transmission oil mixed with molybdenum or graphite additive

Motorcycle Creeps With The Engine Idling

- Incorrect clutch adjustment
- Clutch plates warped
- Faulty clutch lifter
- Incorrect engine oil weight

Right Crankcase Cover Removal/Installation

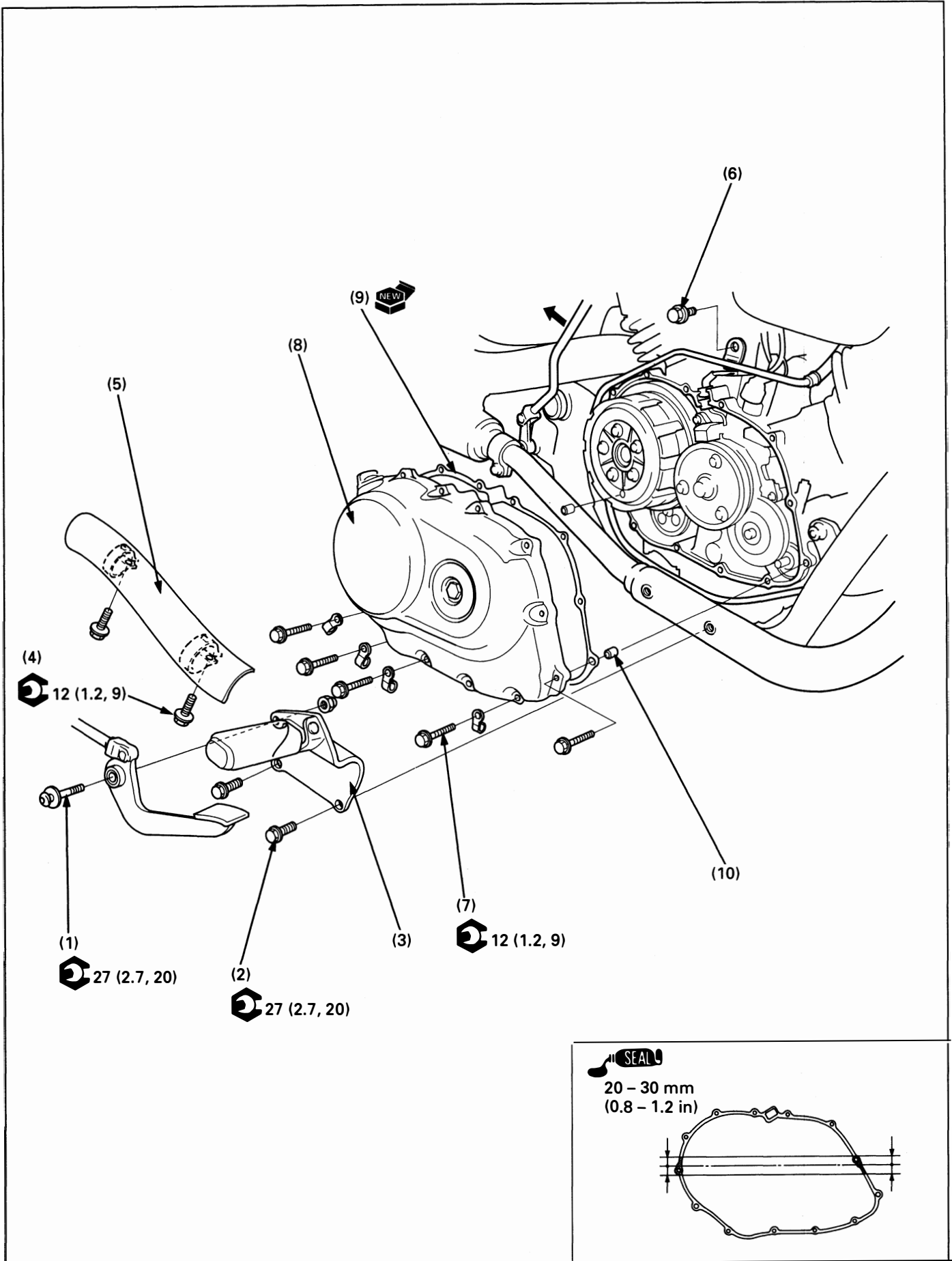

Requisite Service

- Engine oil draining/refilling

Procedure		Q'ty	Remarks
	Removal Order		Installation is in the reverse order of removal,
(1)	Brake pedal pivot bolt/nut	1/1	
(2)	Right foot peg bracket bolt	2	
(3)	Right foot peg bracket	2	
(4)	Front exhaust pipe protector bolt	2	
(5)	Front exhaust pipe protector	1	
(6)	Evaporative emission canister pipe bolt	1	California type only
(7)	Right crankcase cover bolt	13	NOTE • Install the clamps in the correct positions and clamp the starter motor cable.
(8)	Right crankcase cover	1	
(9)	Gasket	1	
(10)	Dowel pin	2	

Clutch Removal

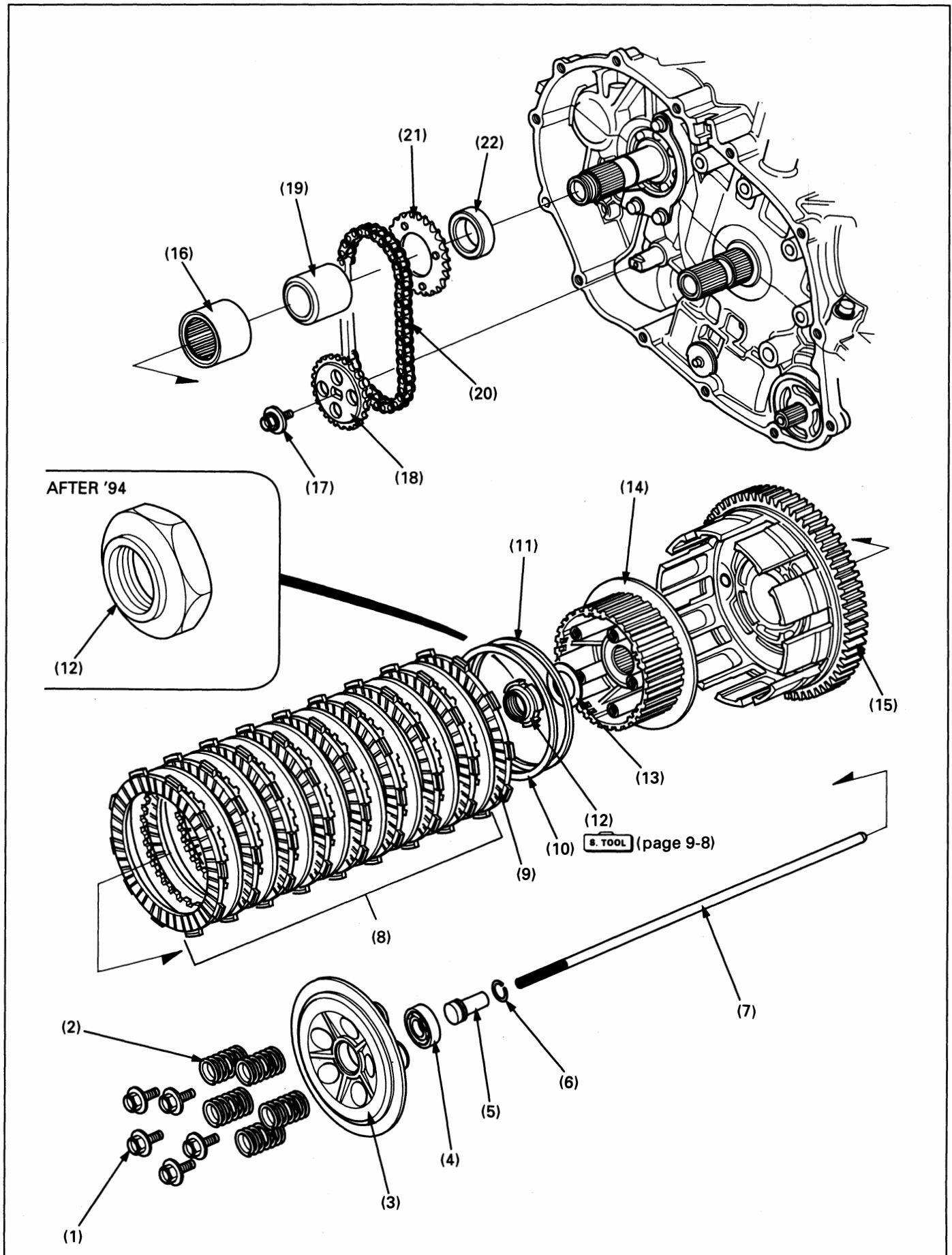

NOTE

- When removing the oil pump driven sprocket, loosen the sprocket bolt before removing the clutch assembly. The bolt is treated with a locking agent so be careful not to damage the bolt when loosening.

Requisite Service

- Right crankcase cover removal (page 9-2)
- Starter clutch removal (page 17-10)

	Procedure	Q'ty	Remarks
	Removal Order		
(1)	Clutch spring bolt	5	
(2)	Clutch spring	5	
(3)	Clutch pressure plate	1	
(4)	Clutch pressure plate bearing	1	
(5)	Clutch lifter guide	1	Detach from the pressure plate bearing only when replacing the bearing.
(6)	Stopper ring	1	
(7)	Lifter rod	1	
(8)	Clutch disk A/clutch plate	8/8	
(9)	Clutch disk B	1	Larger I.D. than clutch disc A
(10)	Judder spring	1	
(11)	Spring seat	1	
(12)	Clutch center lock nut	1	<ul style="list-style-type: none"> • Unstake the lock nut. • Hold the clutch center with the special tool (page 9-8).
(13)	Spring washer	1	
(14)	Clutch center	1	
(15)	Clutch outer	1	
(16)	Needle bearing	1	
(17)	Oil pump driven sprocket bolt	1	
(18)	Oil pump driven sprocket	1	<ul style="list-style-type: none"> • Remove them as an assembly.
(19)	Clutch outer guide	1	
(20)	Oil pump drive chain	1	
(21)	Oil pump drive sprocket	1	
(22)	Collar	1	

Clutch Installation

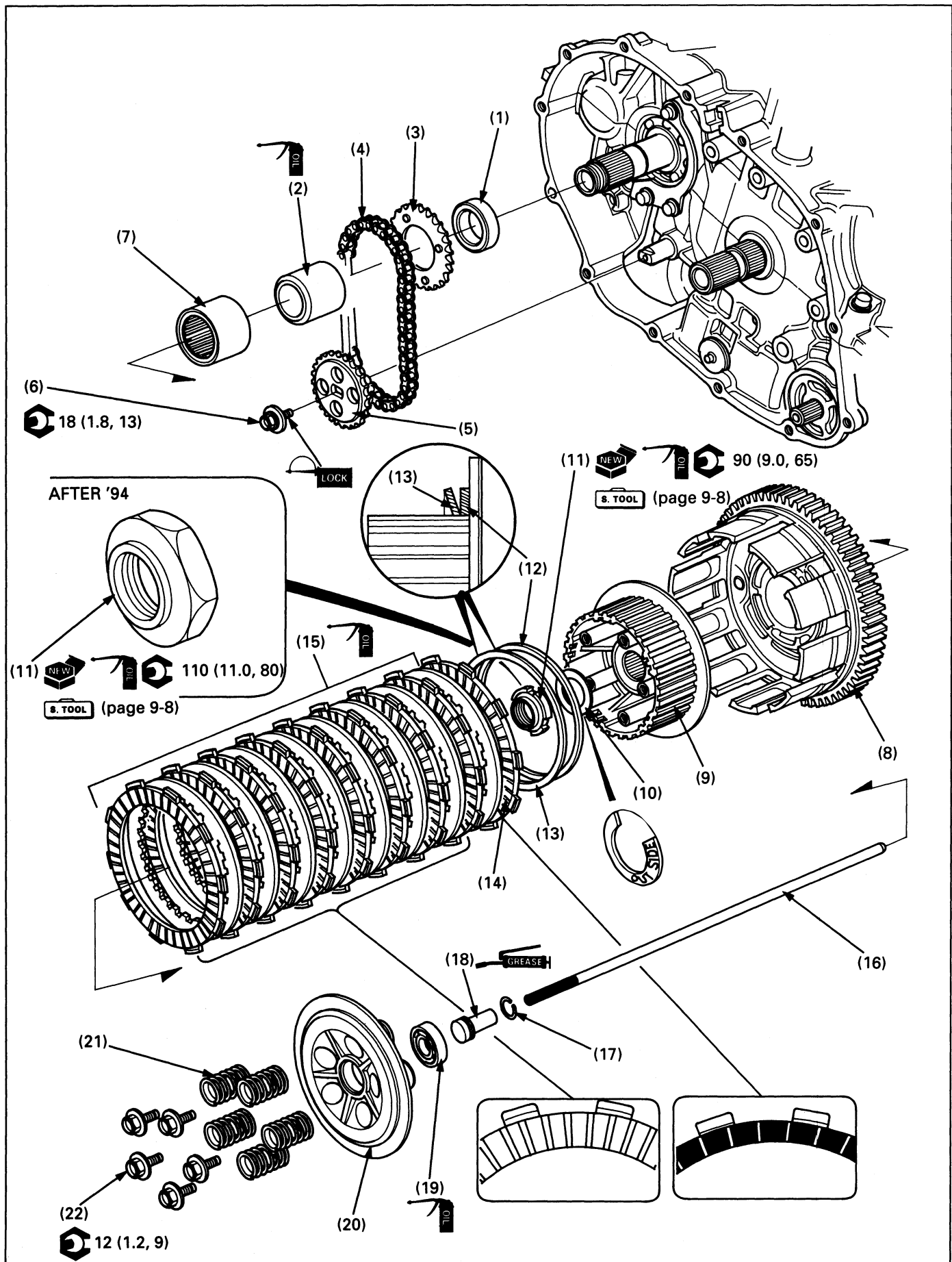

Requisite Service

- Starter clutch installation (page 17-10)

- Right crankcase cover installation (page 9-2)

Procedure		Q'ty	Remarks
	Installation Order		
(1)	Collar	1	
(2)	Clutch outer guide	1	NOTE
(3)	Oil pump drive sprocket	1	• Lubricate the inner and outer sliding surfaces with a engine oil.
(4)	Oil pump drive chain	1	• Install them as an assembly.
(5)	Oil pump driven sprocket	1	• Install the drive sprocket with the boss side facing out.
(6)	Oil pump driven sprocket bolt	1	Clean and apply a locking agent to the threads.
(7)	Needle bearing	1	
(8)	Clutch outer	1	Installation (page 9-8).
(9)	Clutch center	1	
(10)	Spring washer	1	"OUT SIDE" mark facing cover.
(11)	Clutch center lock nut	1	• Hold the clutch center with the special tool (page 9-8). • Stake the lock nut with a punch.
(12)	Spring seat	1	Install the spring seat and judder spring on the clutch center as shown.
(13)	Judder spring	1	
(14)	Clutch disc B	1	Larger I.D. than clutch disc A.
(15)	Clutch disc A/clutch plate	8/8	
(16)	Lifter rod	1	Install the lifter rod as shown.
(17)	Stoppen ring	1	Install securely into the lifter guide groove.
(18)	Clutch lifter guide	1	Install into the pressure plate bearing.
(19)	Pressure plate bearing	1	Install into the pressure plate.
(20)	Pressure plate	1	
(21)	Clutch spring	5	
(22)	Clutch spring bolt	5	Tighten them in a gradual, crisscross pattern.

Clutch System

Clutch Center Lock Nut

Removal

Unstake the clutch center lock nut.

NOTE

- Be careful not to damage the mainshaft threads.

Hold the clutch center with the special tool and loosen the clutch center lock nut. Remove the tools and the lock nut.

S. TOOL

Clutch center holder

07724 - 0050001

Equivalent commercially available in U.S.A.

'94 only:

Lock nut wrench, 26 x 30 mm

07716 - 0020203

Installation

Hold the clutch center with the clutch center holder, and tighten the new lock nut to the specified torque.

Torque: 90 N·m (9.0 kg·m, 65 ft·lb)

S. TOOL

Clutch center holder

07724 - 0050001

Equivalent commercially available in U.S.A.

'94 only:

Lock nut wrench, 26 x 30 mm

07716 - 0020203

Stake a new lock nut with a center punch.

NOTE

- Be careful not to damage the mainshaft threads.

Clutch Outer Installation

Install the clutch outer onto the mainshaft.

Turn the oil pump driven sprocket and align the pins on the oil pump drive sprocket with the holes of the clutch outer.

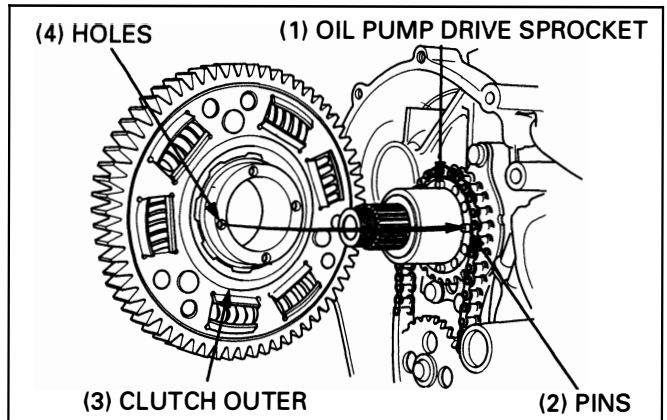
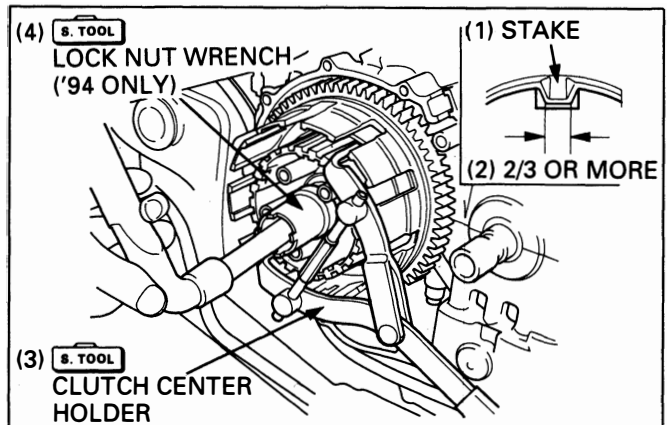
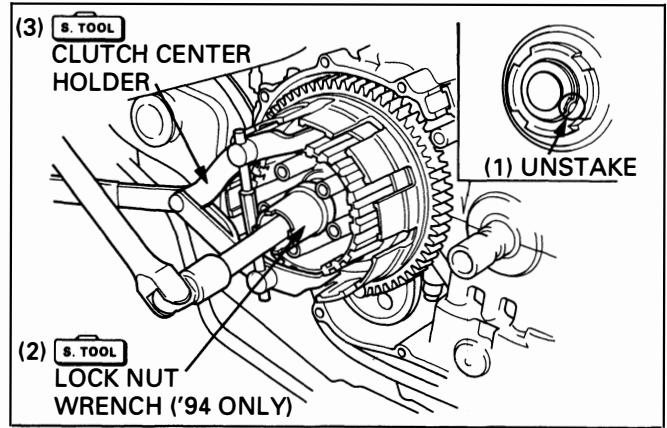

10. Gearshift Linkage

Service Information	10-1	Gearshift Linkage Removal/ Installation	10-4
Troubleshooting	10-1		
Drive Sprocket Cover Removal/ Installation	10-2		

Service Information

- The gearshift linkage maintenance can be done with the engine in the frame.
- Never allow foreign materials to get into the engine.

Troubleshooting

Hard To Shift

- Improper oil viscosity
- Incorrect clutch adjustment
- Bent shift forks
- Bent shift fork shaft
- Bent fork claw
- Loose stopper plate bolt
- Damaged stopper plate and pin
- Damaged gearshift spindle
- Damaged shift drum groove
- Damaged guide pin

Transmission Jumps Out Of Gear

- Worn shift drum stopper arm
- Worn gear engagement dogs or slots
- Weak or broken shift arm return spring
- Loose stopper plate bolt
- Damaged or bent shift fork

Gearshift Pedal Will Not Return

- Weak or broken gearshift spindle return spring
- Bent gearshift spindle

Drive Sprocket Cover Removal/Installation

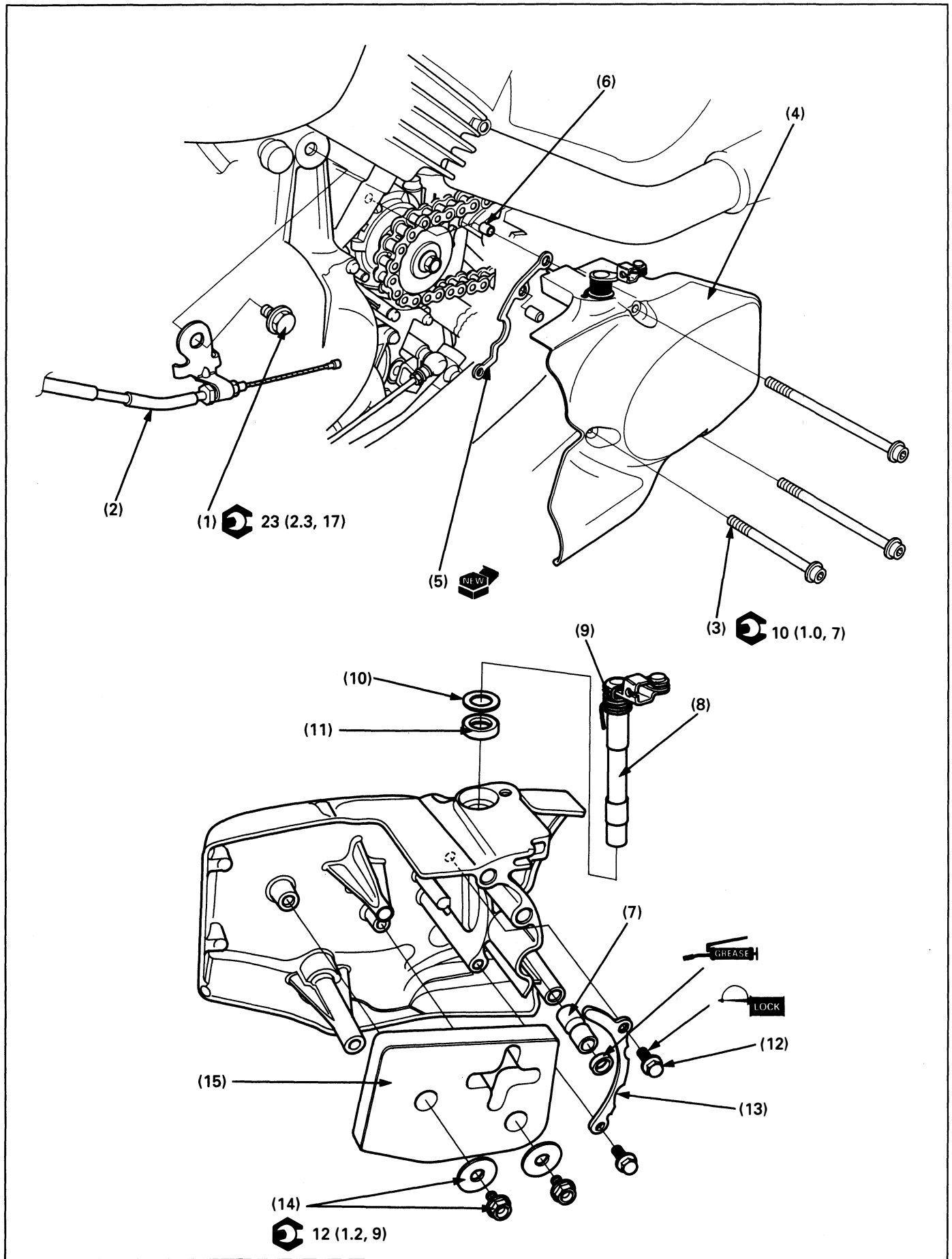

Procedure		Q'ty	Remarks
Removal Order			Installation is in the reverse order of removal.
(1)	Clutch cable holder bolt	1	
(2)	Clutch cable/holder	1	
(3)	Drive sprocket cover bolt	3	
(4)	Drive sprocket cover	1	
(5)	Gasket	1	
(6)	Dowel pin	2	
Disassembly Order			Assembly is in the reverse order of disassembly. Remove the piece by turning the lifter arm clockwise.
(7)	Clutch lifter piece	1	
(8)	Clutch lifter arm	1	
(9)	Return spring	1	
(10)	Washer	1	
(11)	Dust seal	1	
(12)	Drive chain guard bolt	2	
(13)	Drive chain guard	1	
(14)	Drive sprocket cover rubber bolt/washer	2/2	
(15)	Drive sprocket cover rubber	1	

Gearshift Linkage Removal/Installation

(8) SHIFTER PLATE ASSEMBLY

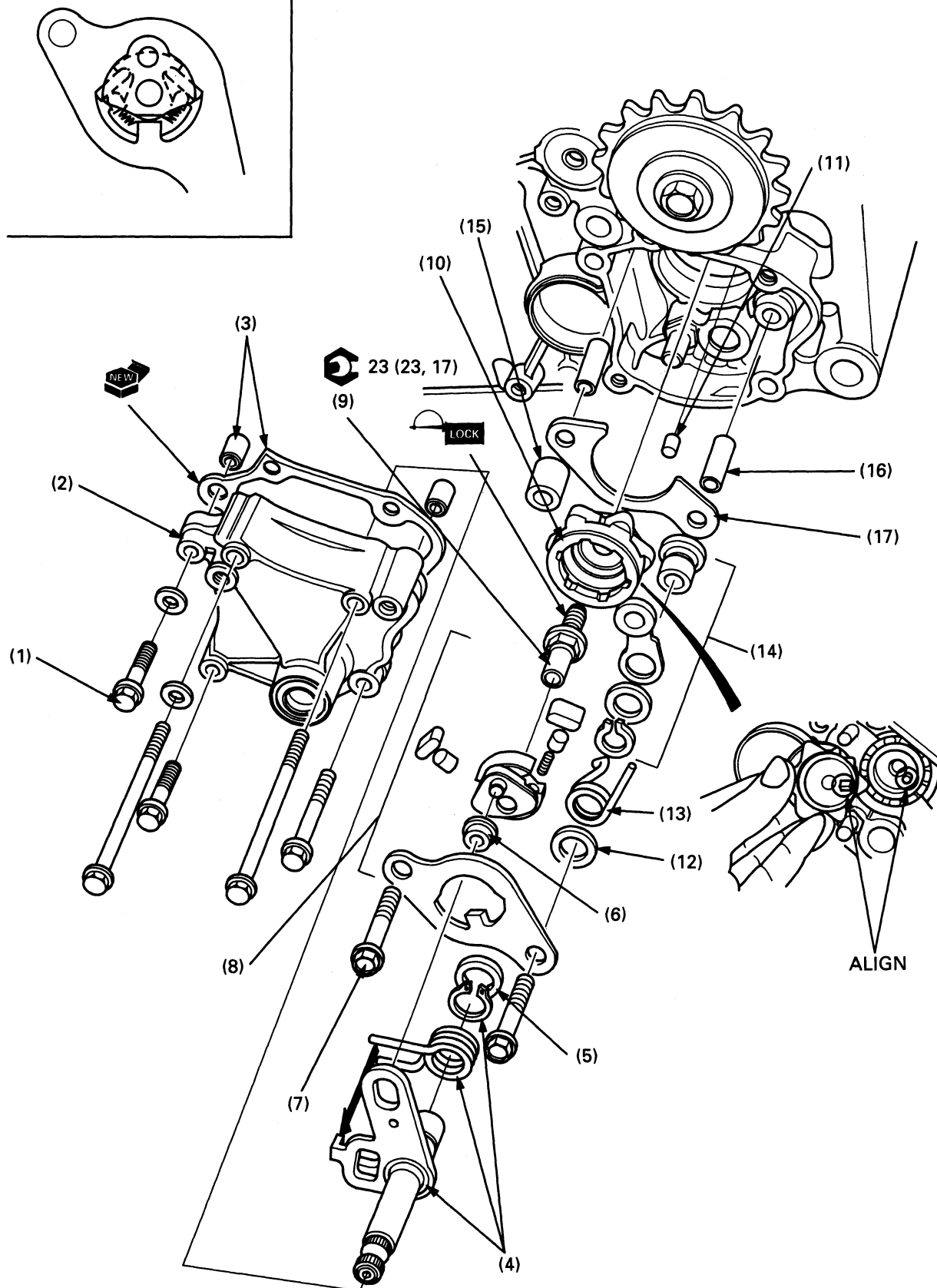

NOTE

- Gearshift linkage service can be performed with the engine in the frame.
- When removing the water pump, it is not necessary to disconnect the water hoses.
- After installation, check the gearshift linkage for proper operation.

Requisite Service

- Drive sprocket cover removal/installation (page 10-2)
- Water pump removal/installation (page 6-7)

Procedure		Q'ty	Remarks
Removal Order			Installation is in the reverse order of removal.
(1)	Gearshift linkage cover bolt/washer	5/2	
(2)	Gearshift linkage cover	1	NOTE • When removing and installing, turn the linkage cover slightly clockwise.
(3)	Gasket/dowel pin	1/2	
(4)	Gear shift spindle assembly	1	Install the shifter collar into the spindle hole, and the return spring onto the return spring pin.
(5)	Washer	1	
(6)	Shifter collar	1	
(7)	Shifter plate attaching bolt	2	
(8)	Shifter plate assembly	1	Lubricate each part with engine oil, and assembly as illustrated. Install on the shift drum center with the drum center positioned at any gear stop except neutral.
(9)	Shift drum center bolt	1	Apply a locking agent to the threads.
(10)	Shift drum center	1	Install by aligning the cut out with the dowel pin as shown.
(11)	Dowel pin	1	
(12)	Washer	1	
(13)	Stopper arm spring	1	
(14)	Stopper arm assembly	1	Install the snap ring with the chamfered side facing inside, and seat fully in the flange collar groove.
(15)	Collar	1	
(16)	Dowel pin	2	
(17)	Shift drum bearing stopper plate	1	

MEMO

11. Crankshaft/Piston/Transmission

Service Information	11-1	Countershaft Disassembly/Assembly	11-12
Troubleshooting	11-1	Crankcase Combination	11-14
Crankcase Separation	11-2	Crankshaft Bearing Replacement	11-16
Crankshaft/Connecting Rod Removal/Installation	11-4	Connecting Rod Selection	11-18
Piston Disassembly/Assembly	11-6	Liquid Sealant Application	11-18
Transmission Removal/Installation	11-8	Crankcase Bolt Location	11-18
Mainshaft Disassembly/Assembly	11-10		

Service Information

- This section covers crankcase separation for service of the crankshaft, cylinder sleeve, piston and transmission.
- The following parts must be removed before servicing.

Service Item	Removed Components
Connecting rod	<ul style="list-style-type: none"> • Cylinder head (page 8-2) • Piston (page 11-6)
Crankshaft	<ul style="list-style-type: none"> • Crankcase separation (page 11-2) • Starter clutch (page 17-10) • Flywheel (page 15-10) • Connecting rod bearing cap (page 11-4)
Transmission	<ul style="list-style-type: none"> • Gearshaft linkage (page 10-4) • Crankcase separation (page 11-2)

- Mark and store the bearing inserts for reassembly. If the inserts are improperly installed they will block the oil holes, causing insufficient lubrication and eventual engine seizure.
- Prior to assembling the crankcase halves apply a sealant to their mating surface. Wipe off excess sealant thoroughly.
- Mark and store the disassembled parts to ensure that they are reinstalled in their original locations.
- Remove the piston, cylinder sleeve and connecting rod as an assembly.
- Be careful not to damage the crankshaft main journal bearing while removing or installing the crankshaft.
- All bearing inserts are select fitted and are identified by color code. Select replacement bearings from the selection table (page 11-16).
- After installing new bearings, recheck them with plastigauge to verify clearance.
- Apply molybdenum disulfide oil to the main journals and crankpins during assembly.

Troubleshooting

Cylinder Compression Is Too Low, Or Engine Is Hard To Start

- Worn, stuck or broken piston ring
- Worn or damaged cylinder or piston

Cylinder Compression Is Too High, Or Engine Overheats Or Knocks

- Carbon deposits on the cylinder head and/or piston

Piston Sounds

- Worn cylinder, piston and/or piston ring
- Worn piston pin hole and piston pin
- Worn connecting rod small end

Excessive Smoke

- Worn, stuck or broken piston ring
- Weak valve stem seal

Excessive Noise

- Worn connecting rod big-end bearing
- Bent connecting rod
- Worn crankshaft main bearing
- Worn transmission bearing

Engine Vibration

- Excessive crankshaft runout

Hard To Shift

- Improper clutch operation
- Incorrect transmission oil weight
- Incorrect clutch adjustment
- Bent shift fork
- Bent fork shaft
- Bent fork claw
- Damaged shift drum cam grooves
- Bent shift spindle

Transmission Jumps Out Of Gear

- Worn gear dogs or slots
- Bent fork shaft
- Broken shift drum stopper
- Worn or bent shift forks
- Broken shift linkage return spring
- Worn gear shift fork claw

Crankcase Separation

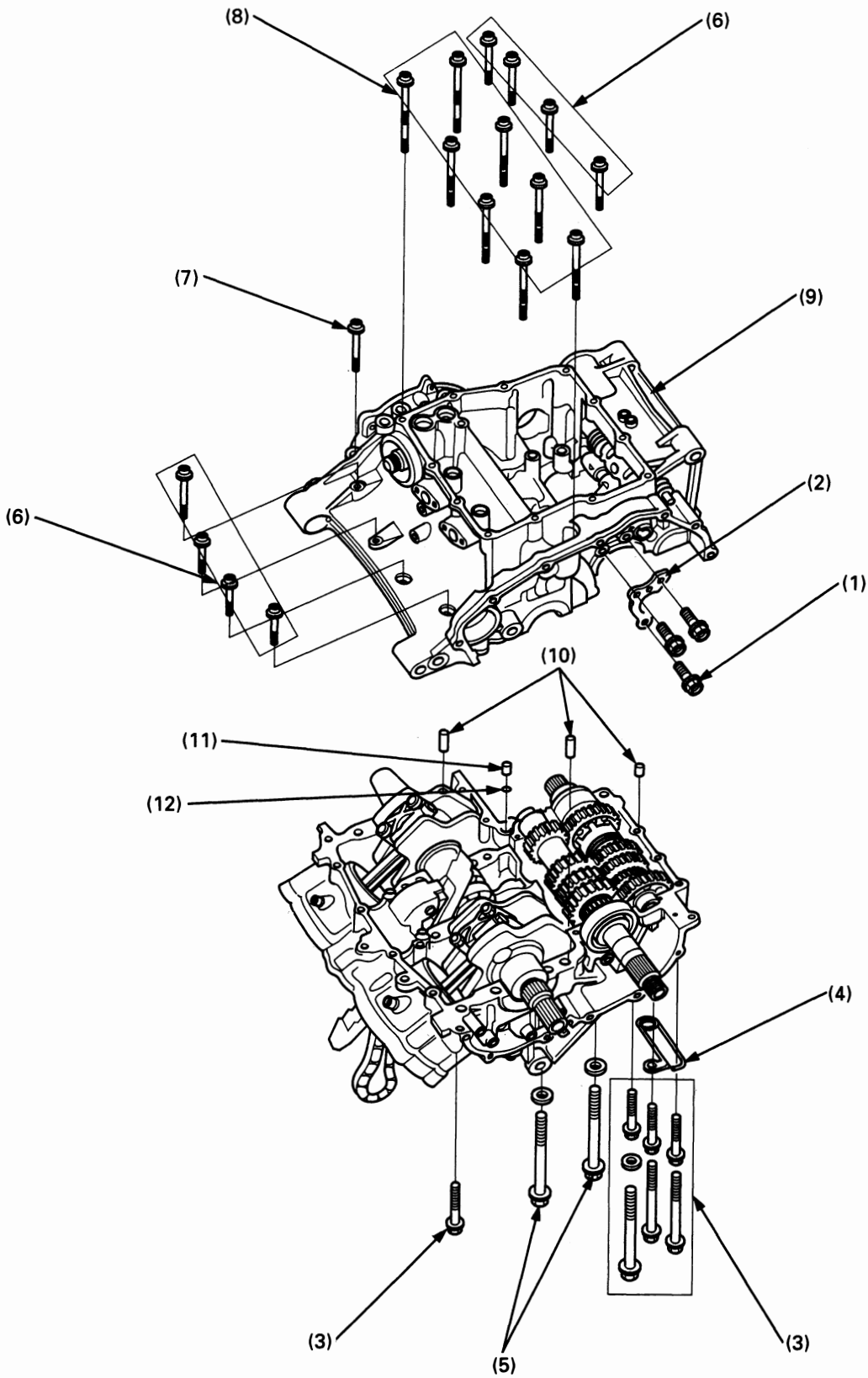

NOTE

- Before removing the parts, make a note of their location for correct installation.

Requisite Service

- Engine removal (page 7-2)
- Clutch removal (page 9-4)
- Alternator cover removal (page 15-10)
- Oil pump removal (page 4-3)

Procedure		Q'ty	Remarks
Separation Order			
Upper Crankcase Side			
(1)	Mainshaft bearing stopper plate bolt	3	Loosen gradually.
(2)	Mainshaft bearing stopper plate	1	
(3)	Upper crankcase bolt, 6 mm/washer	7/1	
(4)	Cable guide	1	
(5)	Upper crankcase bolt, 10 mm/washer	2/2	
Lower Crankcase Side			
(6)	Lower crankcase bolt, 6 mm	8	Loosen in a gradual, crisscross pattern.
(7)	Lower crankcase bolt, 8 mm	1	
(8)	Lower crankcase bolt, 9 mm	8	Loosen in a gradual, crisscross pattern.
(9)	Lower crankcase	1	
(10)	Dowel pin	3	
(11)	Oil orifice	1	
(12)	O-ring	1	

Crankshaft/Connecting Rod Removal/Installation

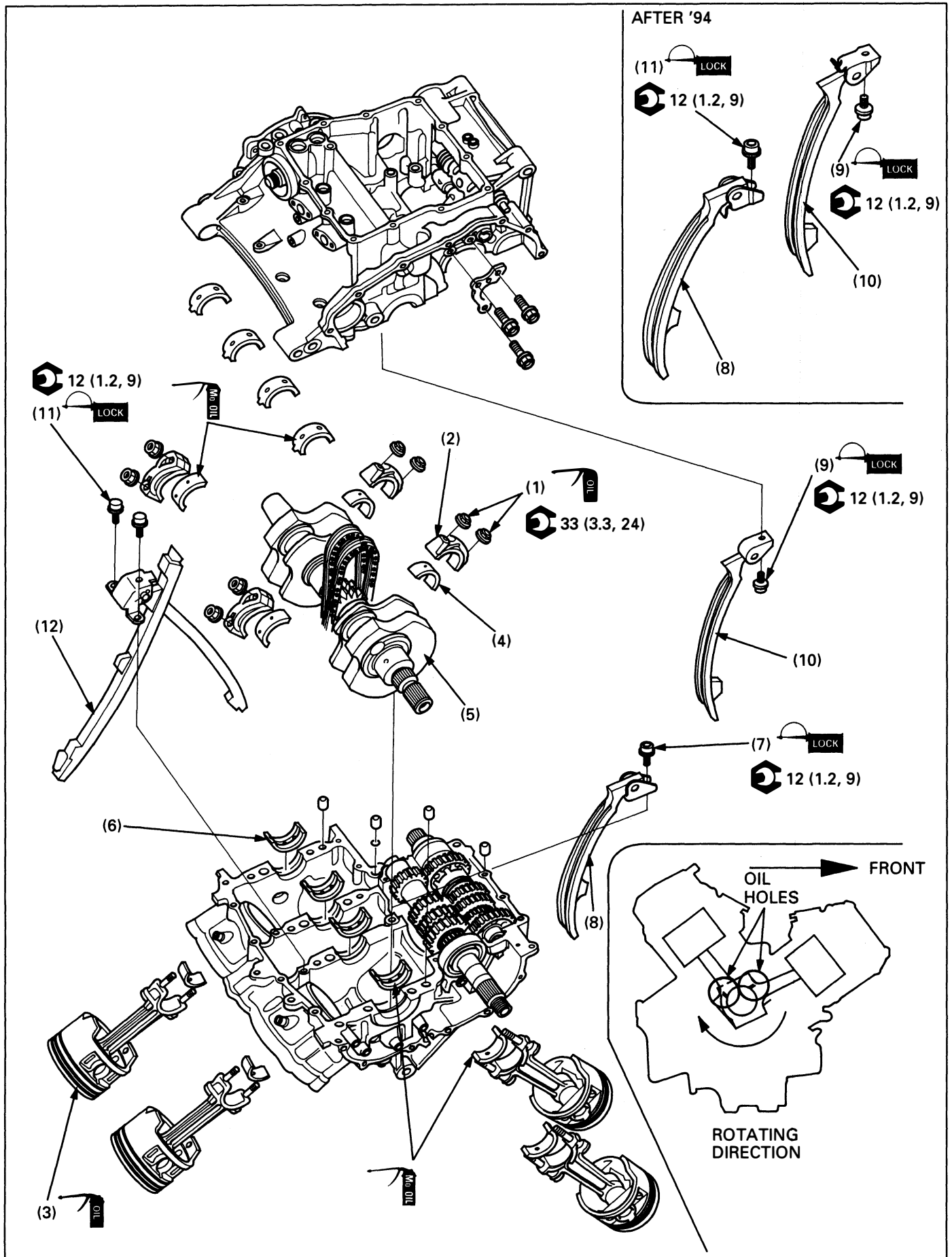

NOTE

- Mark all parts during disassembly so they can be replaced in their original locations.
- All bearing inserts are select fitted and are identified by color code. Select replacement bearings from the code table (page 11-16). After installing new bearings, recheck them with plastigauge to verify the clearance.
- Apply molybdenum disulfide oil to the connecting rod/main journal bearings, main journal and crankpin.

Requisite Service

- Refer to Service Information (page 11-1)

Procedure		Q'ty	Remarks
Removal Order			Installation is in the reverse order of removal.
(1)	Connecting rod bearing cap nut	8	
(2)	Connecting rod bearing cap	4	NOTE
(3)	Connecting rod/piston assembly	4	• Note the direction of the bearing cap. CAUTION • Do not try to remove the connecting rod/piston assembly from the bottom of the cylinder. The oil ring will become wedged in the gap between the cylinder liner and the upper crankcase.
(4)	Connecting rod bearing	8	Wipe all oil from bearing seating areas.
(5)	Crankshaft	1	
(6)	Crankshaft main journal bearing	8	Wipe all oil from bearing seating areas.
(7)	Front cam chain tensioner slipper bolt	1	
(8)	Front cam chain tensioner slipper	1	
(9)	Rear cam chain tensioner slipper bolt	1	
(10)	Rear cam chain tensioner slipper	1	
(11)	Front/rear cam chain slipper bolt	2	
(12)	Front/rear cam chain slipper	1	
Installation Order			
(12)	Front/rear cam chain slipper	1	
(11)	Front/rear cam chain slipper bolt	2	Clean and apply a locking agent to the threads.
(10)	Rear cam chain tensioner slipper	1	
(9)	Rear cam chain tensioner slipper bolt	1	Clean and apply a locking agent to the threads.
(8)	Front cam chain tensioner slipper	1	
(7)	Front cam chain tensioner slipper bolt	1	Clean and apply a locking agent to the threads.
(6)	Crankshaft main journal bearing	8	NOTE • At installation, align the oil holes between the crankcase and bearing, and the bearing tabs with the groove in the crankcase.
(5)	Crankshaft	1	
(4)	Connecting rod bearing	8	NOTE • At installation, align the oil holes between the connecting rod and bearing, and the bearing tabs with the groove in the connecting rod and bearing cap.
(3)	Connecting rod/piston assembly	4	NOTE • Each connecting rod has an identification mark; "ML7-F" (Front), "ML7-R" (Rear). • At installation, install the connecting rod/piston assembly with the oil hole on the connecting rod facing opposite the rotating direction of the crankshaft.
(2)	Connecting rod bearing cap	4	
(1)	Connecting rod bearing cap nut	8	NOTE • At installation, apply engine oil to the threads and seating surface of the nut. • Tighten the nuts gradually and alternately.

Piston Disassembly/Assembly

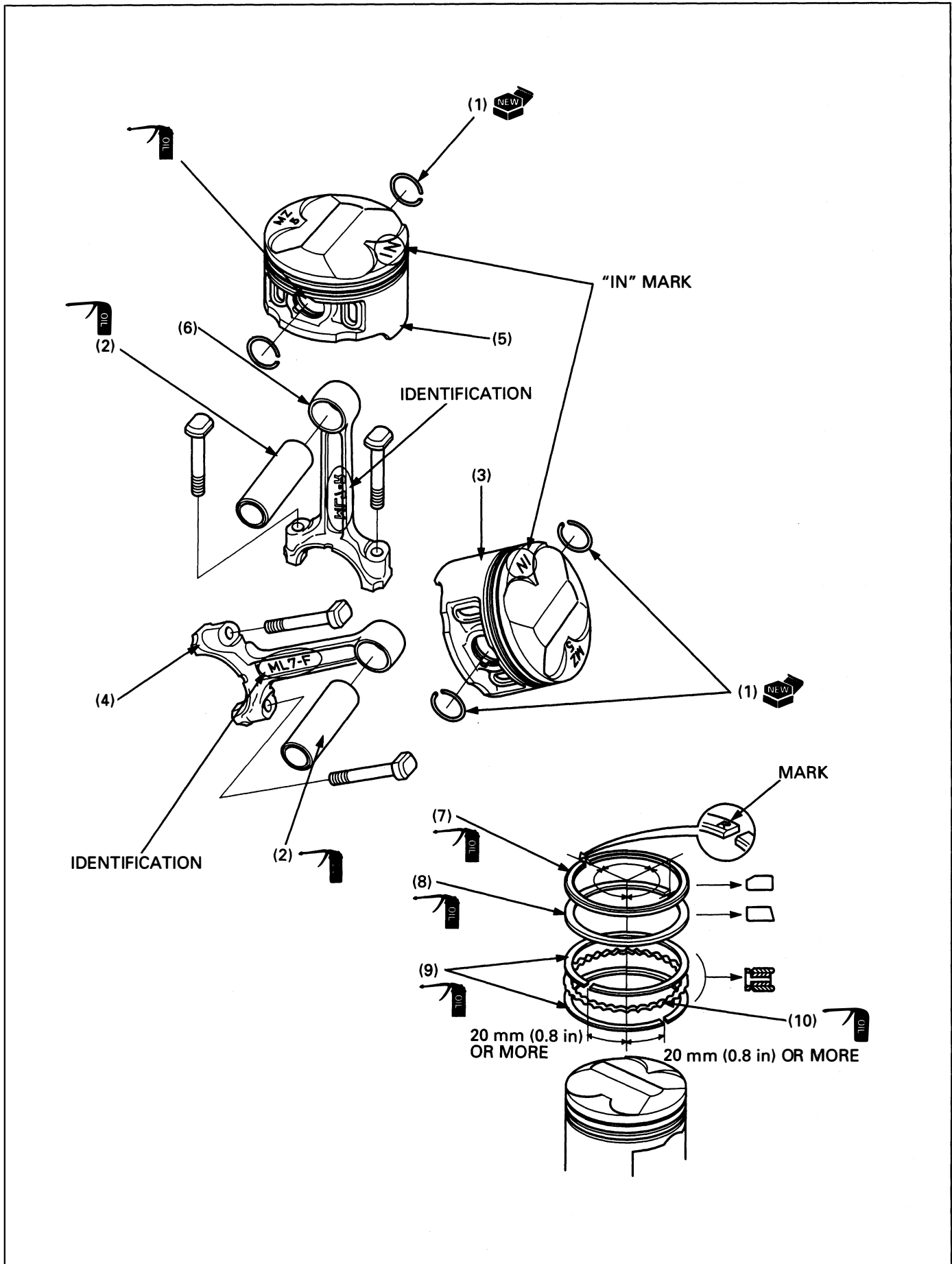

NOTE

- Apply molybdenum disulfide oil to the connecting rod small end and piston pin.

Requisite Service

- Piston removal (page 11-4)

Procedure		Q'ty	Remarks
(1)	Disassembly Order Piston pin clip	8	Assembly is in the reverse order of disassembly. CAUTION • Do not reuse the piston pin clips. NOTE • Apply molybdenum disulfide oil to the piston pin and connecting rod small end. NOTE • Identify the front connecting rod by the marking "ML7-F". Install the piston on the front connecting rod so that the "IN" mark on the piston head faces the oil hole side of the connecting rod. • It is not necessary to remove the piston rings unless they need replacing. NOTE • Identify the rear connecting rod by the marking "ML7-R". Install the piston on the rear connecting rod so that the "IN" mark on the piston head faces the side opposite the connecting rod oil hole. • It is not necessary to remove the piston rings unless they need replacing. At installation, install the piston rings with their marks facing up.
(2)	Piston pin	4	
(3)	Front piston assembly	2	
(4)	Front connecting rod	2	
(5)	Rear piston assembly	2	
(6)	Rear connecting rod	2	
(7)	Top ring	4	
(8)	Second ring	4	
(9)	Side rail	8	
(10)	Spacer	4	

Transmission Removal/Installation

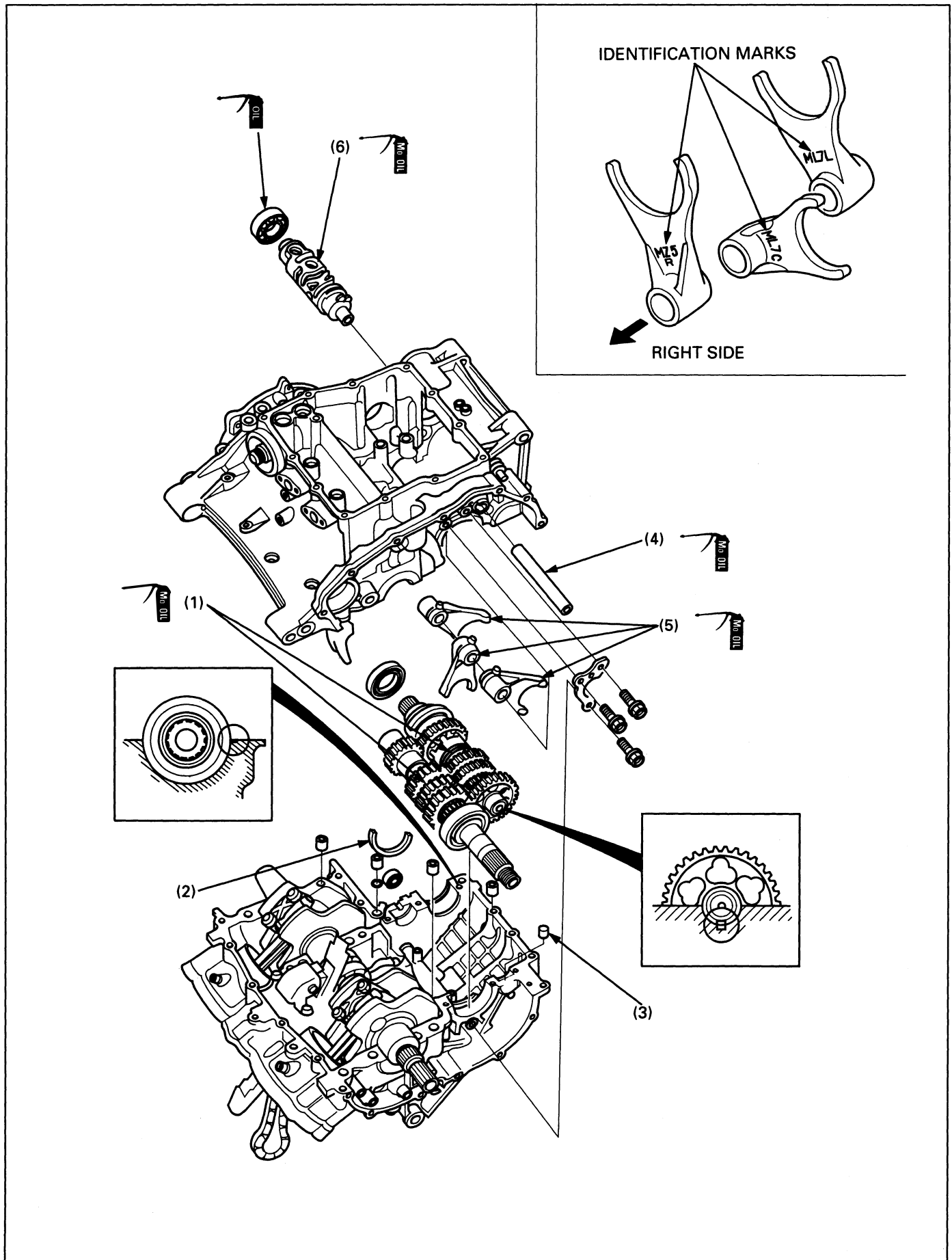

NOTE

- Turn the mainshaft and countershaft to ensure that the gears turn smoothly after reassembly.
- After installation, lubricate gears with clean recommended engine oil.



Requisite Service

- Refer to service Information (page 11-1)

Procedure		Q'ty	Remarks
(1)	Removal Order Mainshaft/countershaft assembly	1	<ul style="list-style-type: none"> • Remove the mainshaft and countershaft as an assembly. • Disassembly (page 11-10, 12)
(2)	Countershaft bearing set plate	1	
(3)	Dowel pin	1	
(4)	Shift fork shaft	1	
(5)	Shift fork	3	
(6)	Shift drum	1	
(6)	Installation Order Shift drum	1	Install them with the identification mark (R: Right, C: Center, L: Left) side facing the right side as shown.
(5)	Shift fork	3	
(4)	Shift fork shaft	1	Fit in the upper crankcase securely. <ul style="list-style-type: none"> • Install the mainshaft and countershaft as an assembly. • Fit the countershaft bearing set pin and plate in the upper crankcase groove, and the dowel pin in the hole in the needle bearing case.
(3)	Dowel pin	1	
(2)	Countershaft bearing set plate	1	
(1)	Mainshaft/countershaft assembly	1	

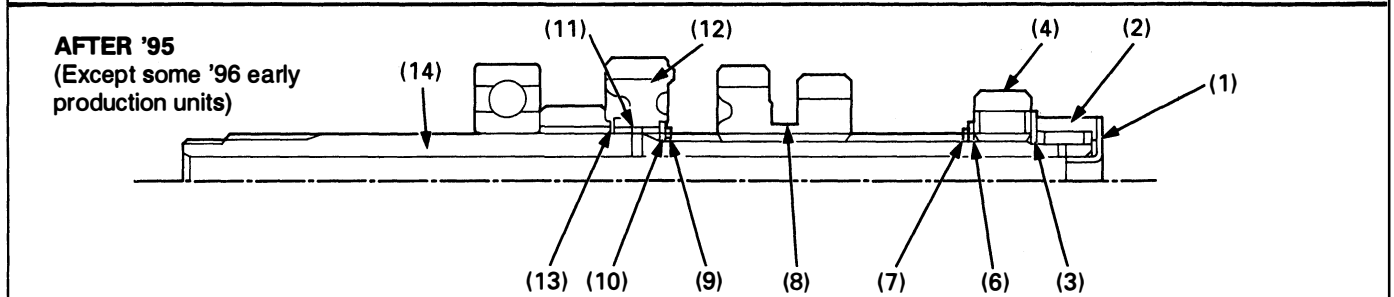
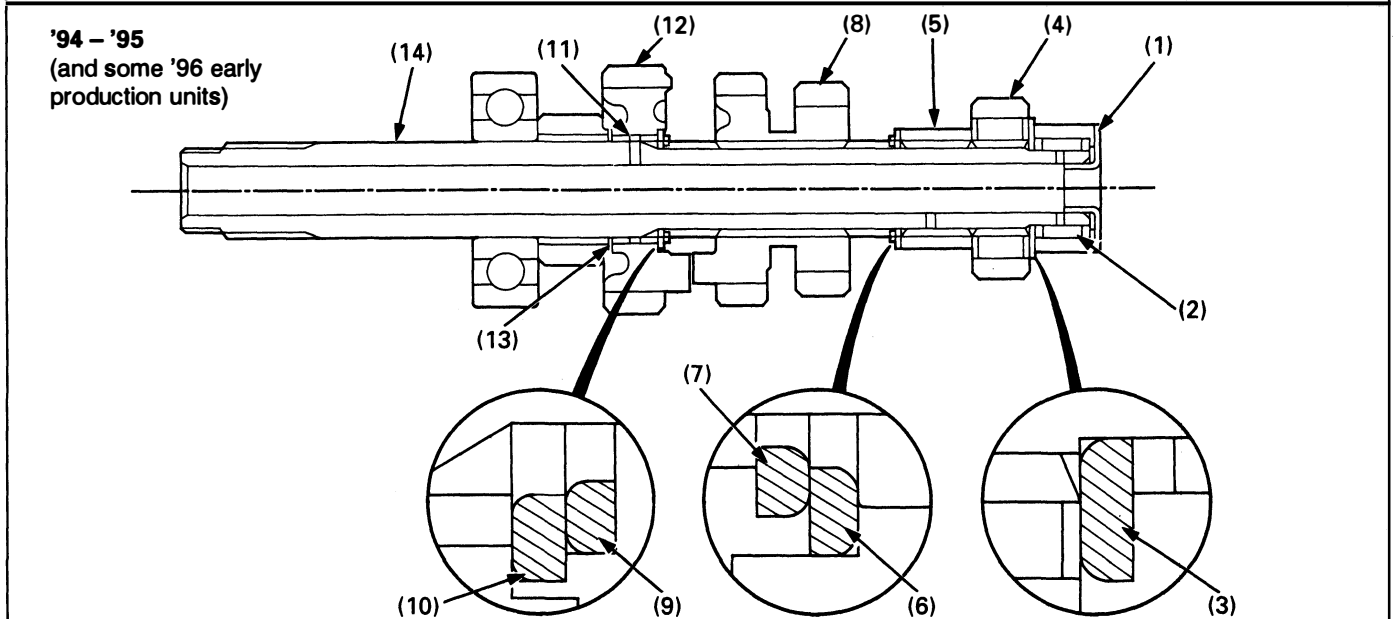
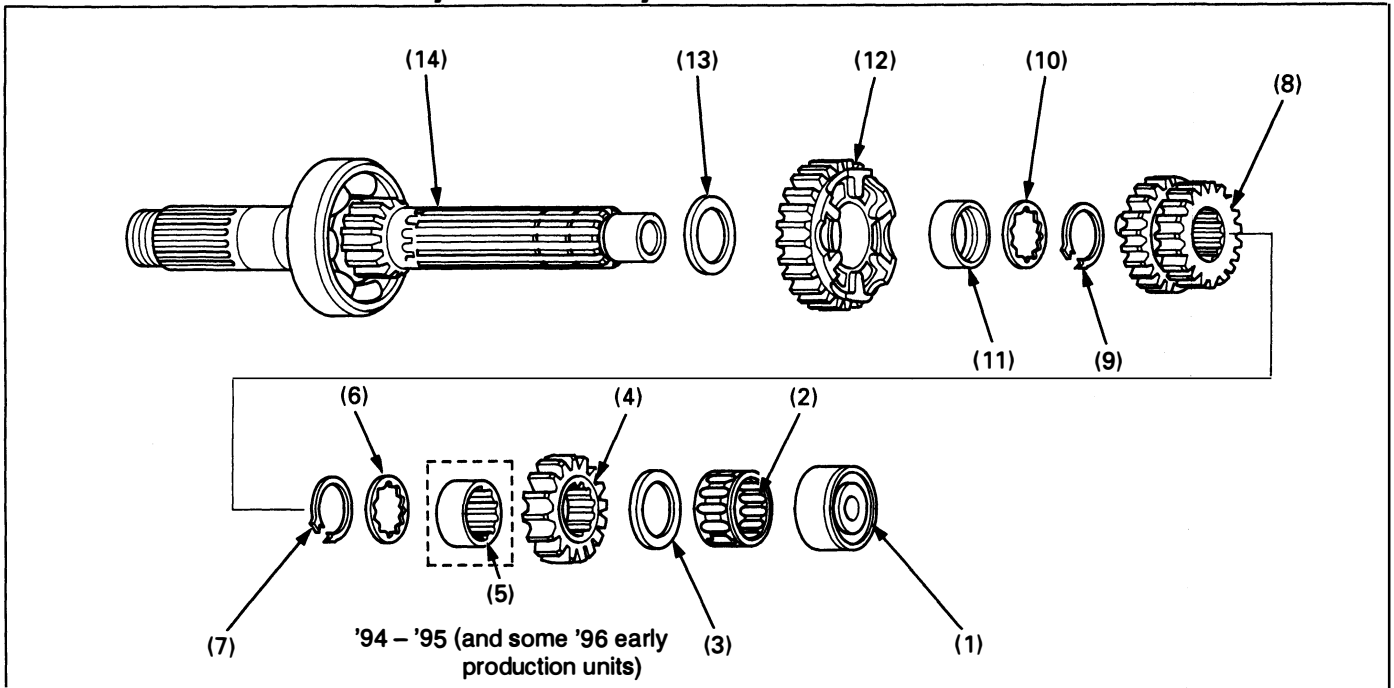
Mainshaft Disassembly/Assembly



 : SHIFTER GEAR GROOVE  : GEAR SLIDING SURFACE

NOTE

- Apply molybdenum oil solution to the shifter gear grooves. Apply oil to all sliding surfaces of the mainshaft, countershaft and bushings.
- Install the thrust washers and snap rings with the chamfered edge facing the thrust load side.
- Refer to section 13 of the Common Service Manual for inspection information.

Requisite Service

- Transmission removal/installation (page 11-8)

Procedure		Q'ty	Remarks
	Disassembly Order		Assembly is in the reverse order of disassembly.
(1)	Needle bearing case	1	
(2)	Needle bearing	1	
(3)	Thrust washer	1	
(4)	M2 gear (17T)	1	
(5)	Collar	1	'94 - '95 (and some '96 early production units)
(6)	Spline washer	1	
(7)	Snap ring	1	
(8)	M3/M4 gear (20/22T)	1	
(9)	Snap ring	1	
(10)	Spline washer	1	
(11)	M5 bushing	1	
(12)	M5 gear (28T)	1	
(13)	Washer	1	
(14)	Mainshaft/M1 gear (13T)	1	

Countershaft Disassembly/Assembly

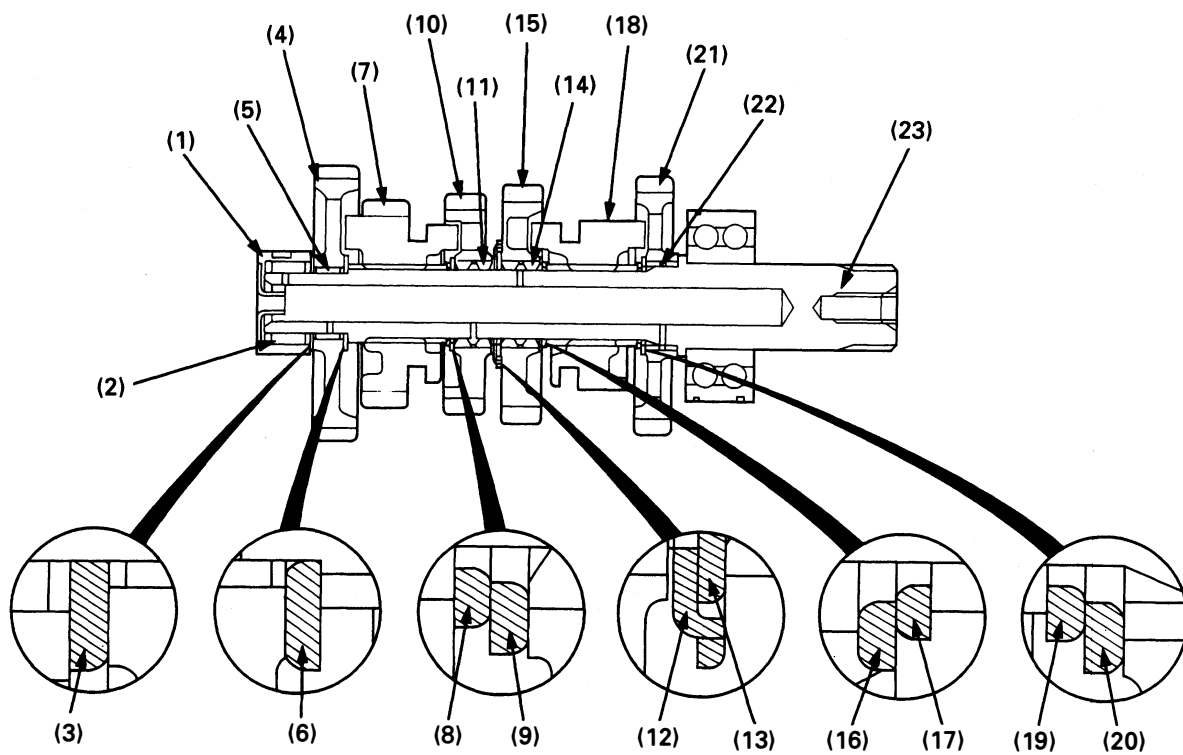
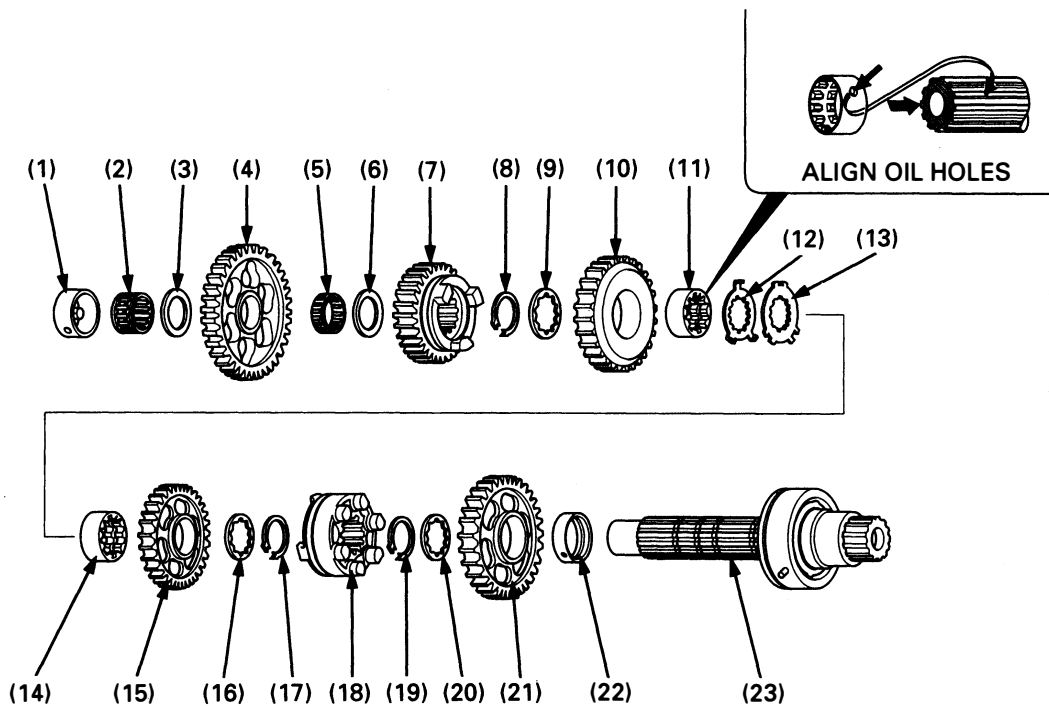

 : SHIFTER GEAR GROOVE

 : GEAR SLIDING SURFACE

NOTE

- Apply molybdenum oil solution to the shifter gear grooves. Apply oil to all sliding surfaces of the mainshaft, countershaft and bushings.
- Install the thrust washers and snap rings with the chamfered edge facing to the thrust load side.
- Refer to section 13 of the common Service Manual for inspection information.

Requisite Service

- Transmission removal/installation (page 11-8)

Procedure		Q'ty	Remarks
Disassembly Order			Assembly is in the reverse order of disassembly.
(1)	Needle bearing case	1	
(2)	Needle bearing	1	
(3)	Thrust washer	1	
(4)	C1 gear (37T)	1	
(5)	Needle bearing	1	
(6)	Thrust washer	1	
(7)	C5 gear (29T)	1	
(8)	Snap ring	1	
(9)	Spline washer	1	
(10)	C4 gear (27T)	1	
(11)	C4 spline bushing	1	Align the oil holes of the bushing and countershaft.
(12)	Tanged washer	1	At assembly, fit the tangs into the lock washer cut-outs.
(13)	Lock washer	1	
(14)	C3 spline bushing	1	
(15)	C3 gear (29T)	1	
(16)	Spline washer	1	
(17)	Snap ring	1	
(18)	Shifter gear	1	
(19)	Snap ring	1	
(20)	Spline washer	1	
(21)	C2 gear (32T)	1	
(22)	C2 bushing	1	
(23)	Countershaft	1	

Crankcase Combination

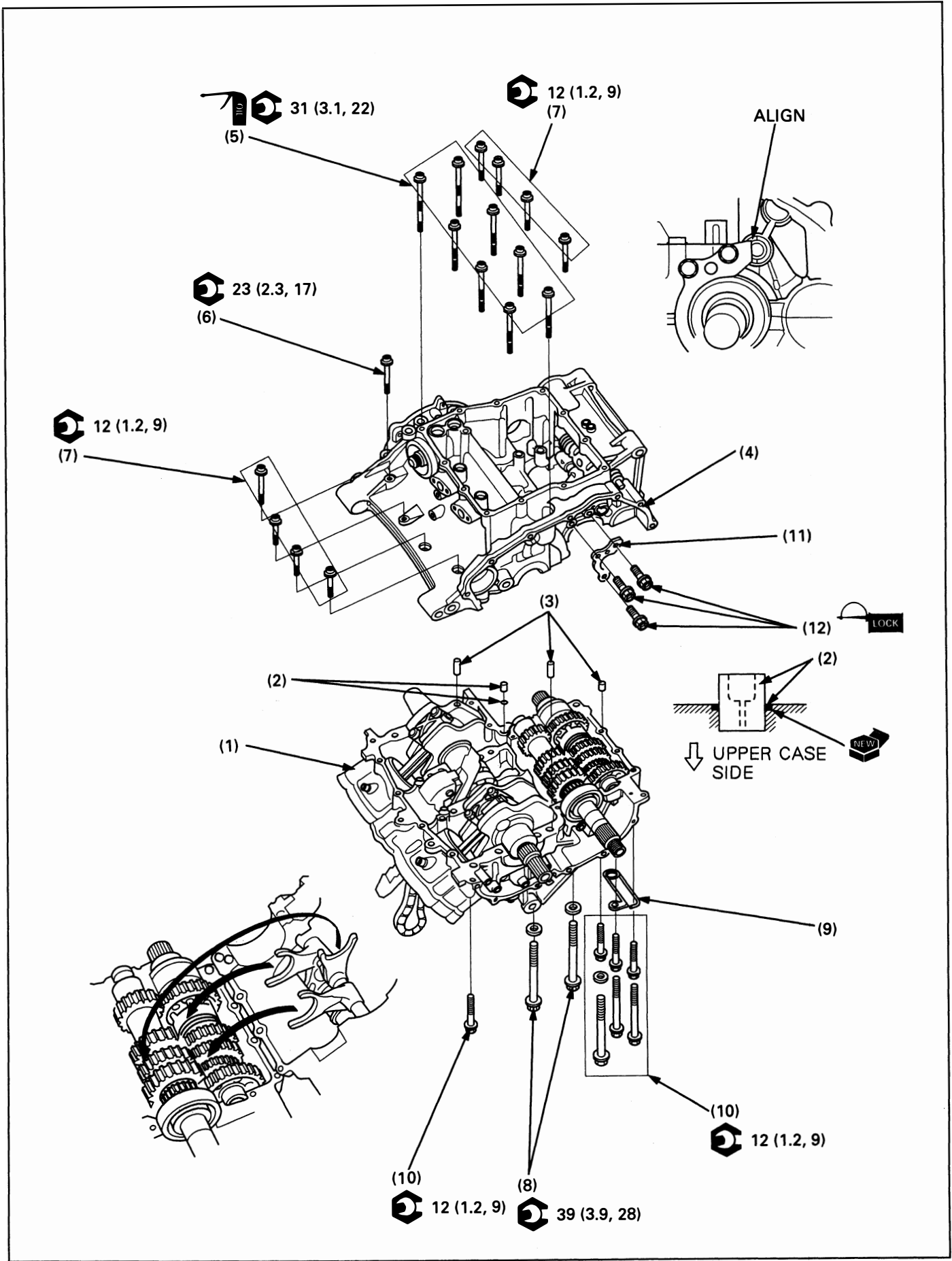

CAUTION

- Install the oil orifice with the larger inner diameter side facing the lower crankcase.
- If the lower crankcase installation is difficult, make sure the transmission assembly is installed correctly.

NOTE

- Refer to page 11-18 for crankcase sealant area and detail of the bolt locations.

Requisite Service

- Oil pump installation (page 4-3)
- Starter motor installation (page 17-7)
- Alternator installation (page 15-10)
- Clutch installation (page 9-6)
- Gearshift linkage installation (page 10-4)
- Cylinder head/camshaft installation (page 8-2)
- Engine installation (page 7-2)

Procedure		Q'ty	Remarks
(1)	Combination Order Upper crankcase	1	<p>CAUTION</p> <ul style="list-style-type: none"> • Do not apply sealant around the oil passage area and main journal bearing area. <p>Refer to page 11-18 for detail for the application area. Install it as illustrated.</p> <p>At installation, make sure the shift forks engage properly with the corresponding gears.</p> <p>Tightening order (page 11-18)</p> <p>Tightening order (page 11-19)</p> <p>Align the cut out of the shift fork shaft with the set plate.</p> <p>Clean and apply a locking agent to the bolt threads.</p>
(2)	Oil orifice/O-ring	1/1	
(3)	Dowel pin	3	
(4)	Lower crankcase	1	
(5)	Lower crankcase bolt, 9 mm	8	
(6)	Lower crankcase bolt, 8 mm	1	
(7)	Lower crankcase bolt, 6 mm/washer	8	
(8)	Upper crankcase bolt, 10 mm/washer	2/2	
(9)	Cable guide	1	
(10)	Upper crankcase bolt, 6 mm/washer	7/1	
(11)	Mainshaft bearing set plate	1	
(12)	Mainshaft bearing set plate bolt	3	

Crankshaft Bearing Replacement

Main Journal Bearing Selection

Record the crankcase I.D. code letters from the pad on the left side of the upper crankcase.

NOTE

- The letters (A, B or C) on the upper crankcase are the codes for the main journal I.D.s. from the left to right.

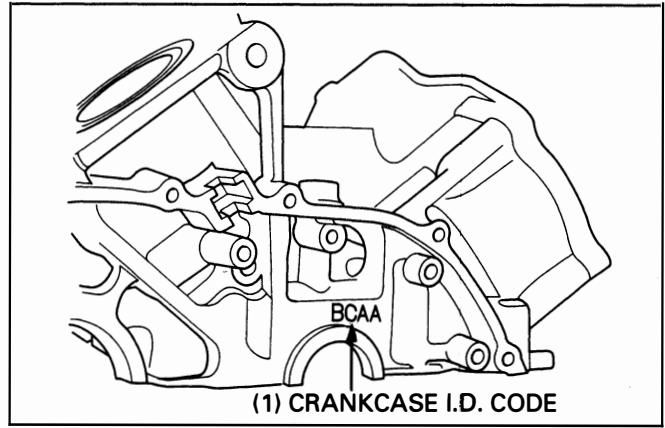

Record the corresponding main journal O.D. code numbers from the crank weight.

NOTE

- The numbers (1, 2 or 3) on the crank weight are the codes for the main journal O.D.s.

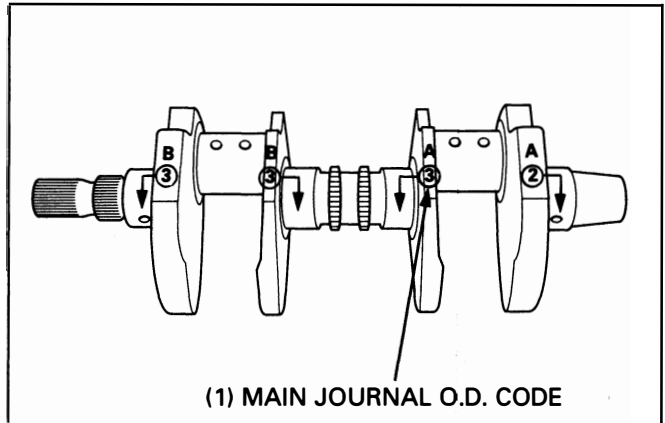

Cross-reference the case and journal codes to determine the replacement bearing color codes.

Main Journal Bearing Selection Table:

Unit: mm (in)

Crankcase I.D. code		A	B	C
Main journal O.D. code		37.000 – 37.005 (1.4567 – 1.4569)	37.006 – 37.011 (1.4569 – 1.4572)	37.012 – 37.018 (1.4572 – 1.4574)
1	34.007 – 34.013 (1.3389 – 1.3391)	Yellow	Green	Brown
2	34.001 – 34.006 (1.3386 – 1.3388)	Green	Brown	Black
3	33.995 – 34.000 (1.3368 – 1.3385)	Brown	Black	Blue

Bearing thickness:

Blue: Thick
 Black: ↑
 Brown: ↓
 Green: Thin
 Yellow: Thin

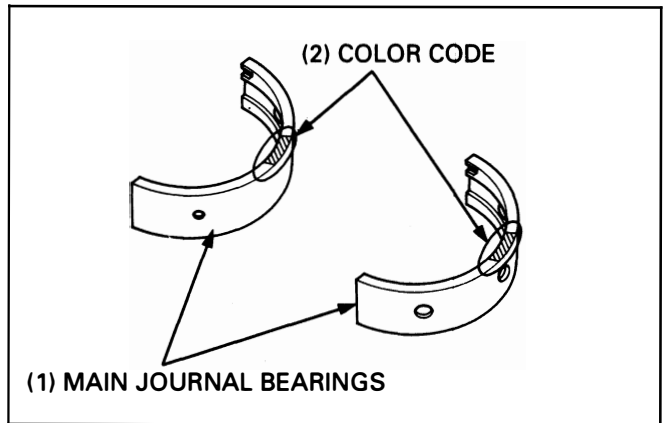

Connecting Rod Bearing Selection

Inspect the connecting rod bearing and crankpin oil clearance (See section 14 of the Common Service Manual).

Record the connecting rod I.D. code number (1, 2 or 3) or measure the I.D. with the bearing cap installed without bearing insert.

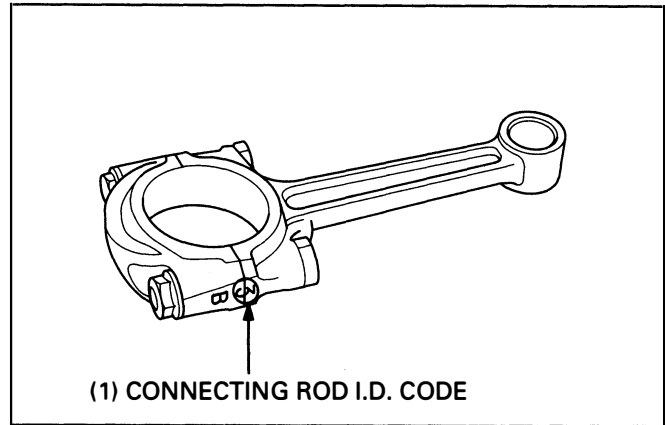

If you replace the crankshaft, record the corresponding crankpin O.D. code number (A, B or C).

If you are reusing the crankshaft, measure the crankpin O.D. with a micrometer.

NOTE

- Numbers (A, B or C) on the crank weight are the codes for the crank pin O.D.s.

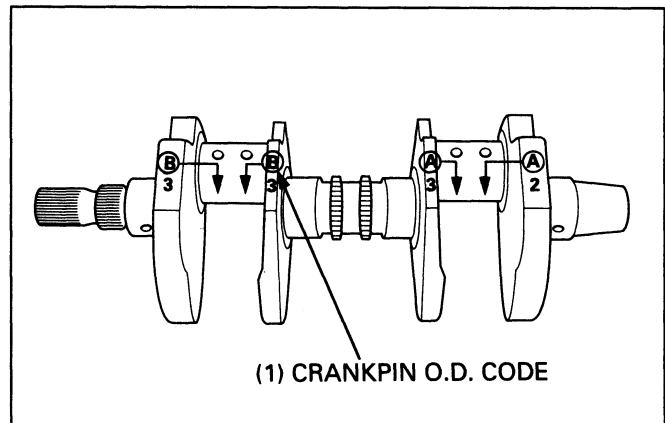

Cross-reference the crankpin and rod codes to determine the replacement bearing color.

NOTE

- One painted mark identifies the front connecting rod bearings and two painted marks the rear.

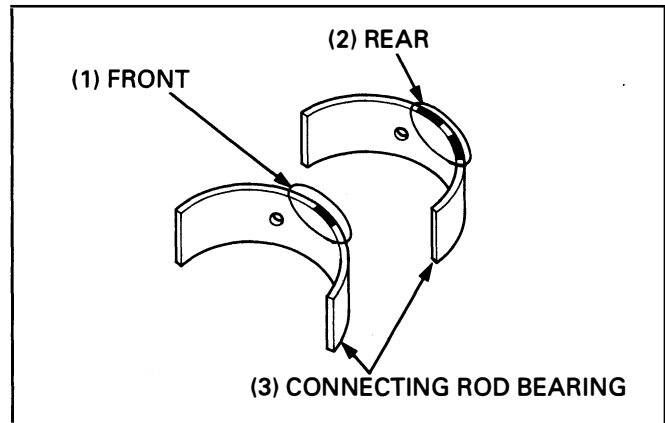

Connecting Rod Bearing selection Table:

Unit: mm (in)

Crank pin O.D. code / Connecting rod I.D. code		A	B	C
		35.995 – 36.000 (1.4171 – 1.4173)	35.989 – 35.994 (1.4169 – 1.4171)	35.982 – 35.988 (1.4166 – 1.4169)
1	39.000 – 39.005 (1.5354 – 1.5356)	Yellow	Green	Brown
2	39.006 – 39.011 (1.5357 – 1.5359)	Green	Brown	Black
3	39.012 – 39.018 (1.5359 – 1.5361)	Brown	Black	Blue

Bearing thickness:

- Blue: Thick
- Black: ↑
- Brown: ↓
- Green: Thin
- Yellow: ↓

Connecting Rod Selection

The weight code is stamped on the connecting rod using an alphabetical code.

If a connecting rod requires replacement, you should select a rod with the same weight code as the original. But if that is unavailable, you may use one of the others specified in the chart.

Original rod code (The rod you will be replacing)	Other rod code on that same crankpin	Replacement rod code
A	B	A, B or C
	C	A or B
B	A	B or C
	C	A or B
C	A	B or C
	B	A, B or C

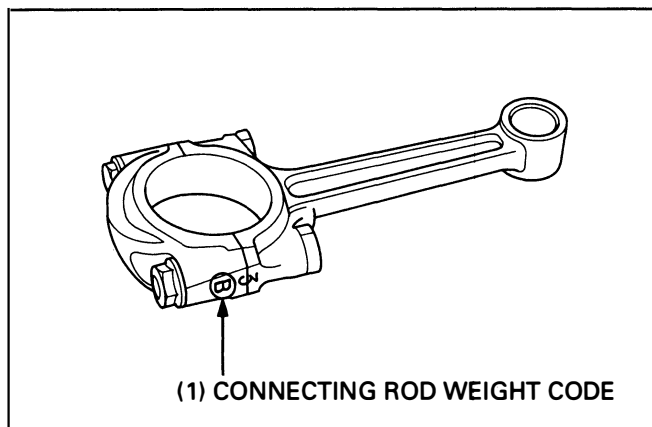

Liquid Sealant Application

Apply a light but through coating of liquid sealant to the crankcase mating surface except to the main bearing journal bolt (lower crankcase, 9 mm) area and the oil passage area as shown.

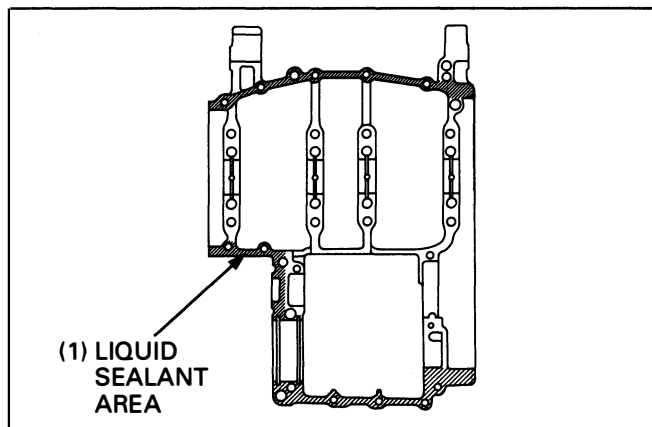

Crankcase Bolt Location

Clean the crankcase 9 mm bolts thoroughly with solvent and blow them dry.

Apply clean engine oil to the 9 mm bolt threads and seating surface and install them.

Loosely install all the lower crankcase bolt.

Make sure the upper and lower crankcase are seated securely.

From the inside to outside, torque the lower crankcase 9 mm bolts in a crisscross pattern in 2 or 3 steps.

Torque: 31 N-m (3.1 kg-m, 22 ft-lb)

Torque the 8 mm bolts, and then the 6 mm bolts.

Torque: 8 mm bolt: 23 N-m (2.3 kg-m, 17 ft-lb)
6 mm bolt: 12 N-m (1.2 kg-m, 9 ft-lb)

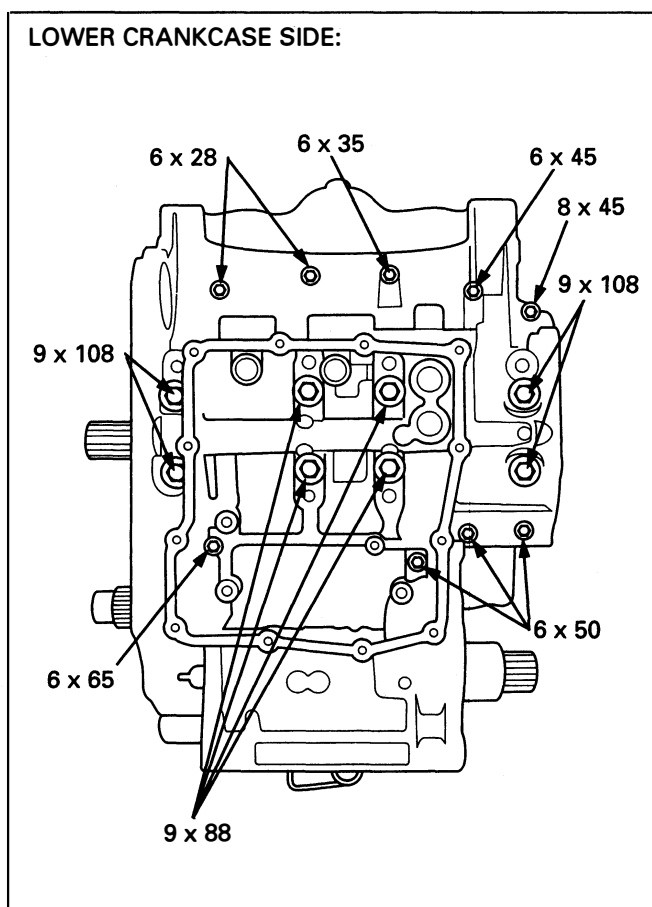

Loosely install all the upper crankcase bolts, the sealing washers and cable guide.

Torque the 10 mm bolts, and then the 6 mm bolts.

Torque: 10 mm bolt: 39 N·m (3.9 kg·m, 28 ft·lb)

6 mm bolt: 12 N·m (1.2 kg·m, 9 ft·lb)

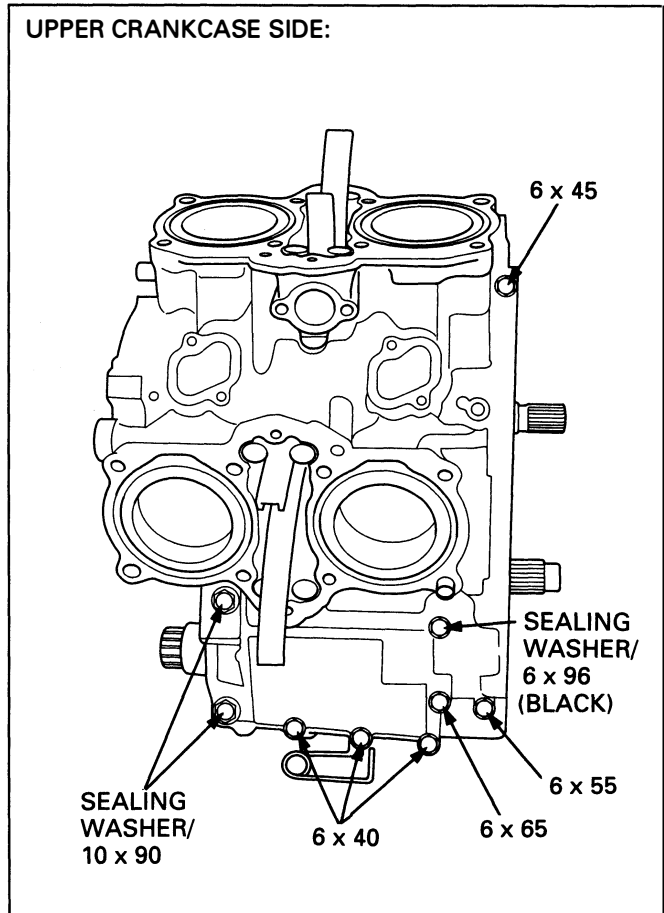

MEMO

12. Front Wheel/Suspension/Steering

Service Information	12-1	Fork Removal/Installation	12-6
Troubleshooting	12-1	Fork Disassembly	12-8
Handlebar Removal/Installation	12-2	Fork Assembly	12-10
Front Wheel Removal/Installation	12-4	Steering Stem Removal/Installation	12-12
Front Wheel Disassembly/Assembly	12-5		

Service Information

⚠ WARNING

- **A contaminated brake disc or pad reduces stopping power. Discard contaminated pads and clean a contaminated disc with a high quality brake degreasing agent.**

- Refer to section 14 for brake system information.
- Refer to section 18 for light, meter and switch information.
- When servicing the front wheel, fork or steering stem, support the motorcycle securely with a safety stand or hoist. Do not use the oil filter as a jack point.

Troubleshooting

Hard Steering

- Steering head bearing adjustment nut too tight
- Faulty steering head bearings
- Insufficient tire pressure
- Faulty tire

Steers To One Side Or Does Not Track Straight

- Bent fork
- Bent front axle
- Wheel installed incorrectly
- Faulty steering head bearings
- Bent frame
- Work wheel bearing
- Worn swingarm pivot components

Front Wheel Wobbling

- Bent rim
- Worn front wheel bearings
- Faulty tire
- Unbalanced tire and wheel

Wheel Turns Hard

- Faulty wheel bearing
- Faulty speedometer gear
- Bent front axle
- Brake drag

Soft Suspension

- Insufficient fluid in fork
- Weak springs
- Low fluid level in fork
- Low tire pressure

Hard Suspension

- Incorrect fluid weight
- Bent fork tubes
- Clogged fluid passage
- High tire pressure

Front Suspension Noisy

- Insufficient fluid in fork
- Loose fork fasteners
- Lack of grease in speedometer gear

Handlebar Removal/Installation

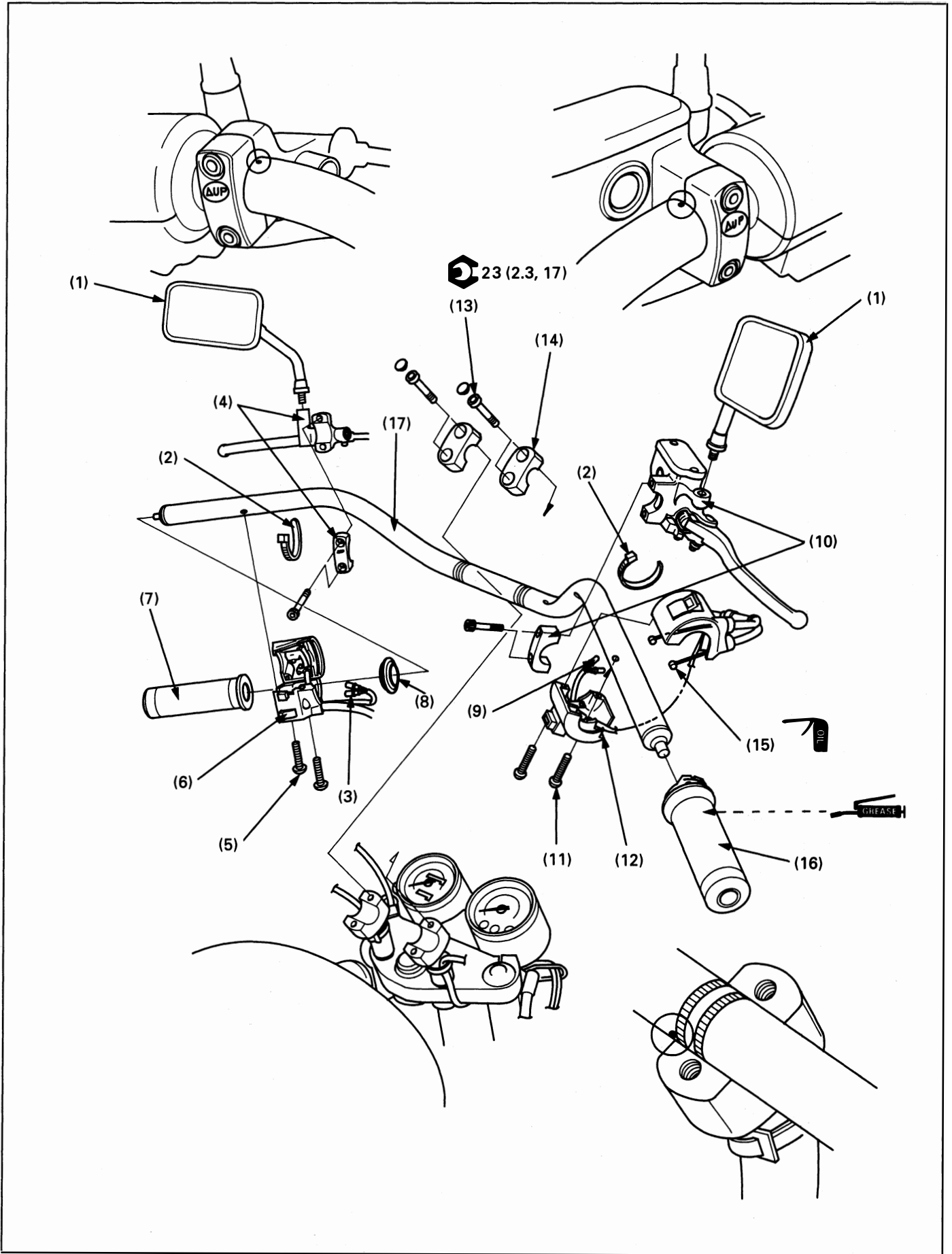

▲ WARNING

- **Contaminates in the system may cause a reduction or loss of braking ability.**

NOTE

- Using wires, hang the front brake master cylinder at least as high as the position it was originally installed at to prevent air from getting into the master cylinder. Do not twist the brake hose.
- Route the cables and wire harnesses properly (page 1-20).
- After installing the handlebar, adjust-
 - the throttle cable
 - the clutch cable
 - the choke cable

Procedure		Q'ty	Remarks
	Removal Order		Installation is in the reverse order of removal.
(1)	Rearview mirror	2	
(2)	Wire band	2	
(3)	Clutch switch connector	2	
(4)	Clutch lever assembly	1	Align the split between the holder and lever support with the punch mark on the handlebar and face the holder "UP" mark upward. Tighten the upper bolt first, then the lower bolt.
(5)	Left handlebar switch housing screw	2	Tighten the front screw first, then the rear screw.
(6)	Left handlebar switch housing	1	Align the locating pin in the left handlebar switch with the hole in the handlebar.
(7)	Handle grip	1	Apply Honda Bond A or Honda Hand Grip Cement (U.S.A. only) to the inside surface of the grip.
(8)	Switch housing side protector	1	
(9)	Brake light switch connector	2	
(10)	Master cylinder	1	Align the split between the holder and master cylinder body with the punch mark on the handlebar and face the holder "UP" mark upward. Tighten the upper bolt first, then the lower bolt.
(11)	Right handlebar switch housing screw	2	Tighten the front screw first, then the rear screw.
(12)	Right handlebar switch housing	1	Align the locating pin in the right handlebar switch with the hole in the handlebar.
(13)	Handlebar holder bolt	4	Tighten the front bolts first, then the rear bolts.
(14)	Handlebar upper holder	2	Install the upper holder with its punch mark facing forward.
(15)	Throttle cable end	2	
(16)	Throttle pipe	1	
(17)	Handlebar	1	Place the handlebar onto the lower holder and align the punch marks on the handlebar with mating surface of the handlebar holder.

Front Wheel Removal/Installation

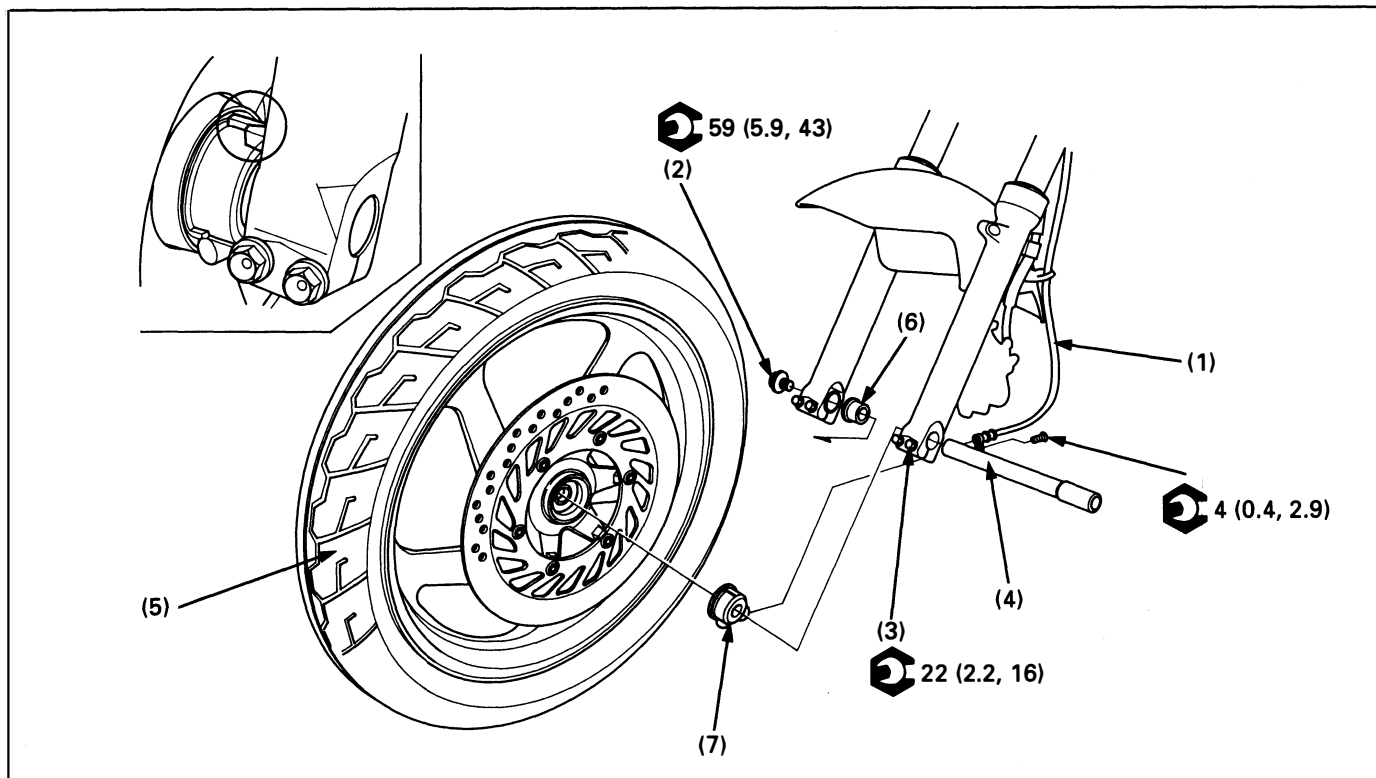

⚠ WARNING

- A contaminated brake disc or pad reduces stopping power. Discard contaminated pads and clean a contaminated disc with a high quality brake degreasing agent.

CAUTION

- Do not use the oil filter as a jack point.

NOTE

- When servicing the front wheel, support the motorcycle using a safety stand or hoist.
- Do not operate the brake lever after the front wheel removed.

Procedure		Q'ty	Remarks
	Removal Order		Installation is in the reverse order of removal.
(1)	Speedometer cable	1	
(2)	Axle bolt	1	
(3)	Axle pinch bolt	4	
(4)	Front axle	1	At installation, apply a thin coating of grease to the front axle.
(5)	Front wheel assembly	1	At installation, align the projection of the speedometer gear box with the projection on the fork leg.
(6)	Side collar	1	
(7)	Speedometer gear box assembly	1	

Front Wheel Disassembly/Assembly

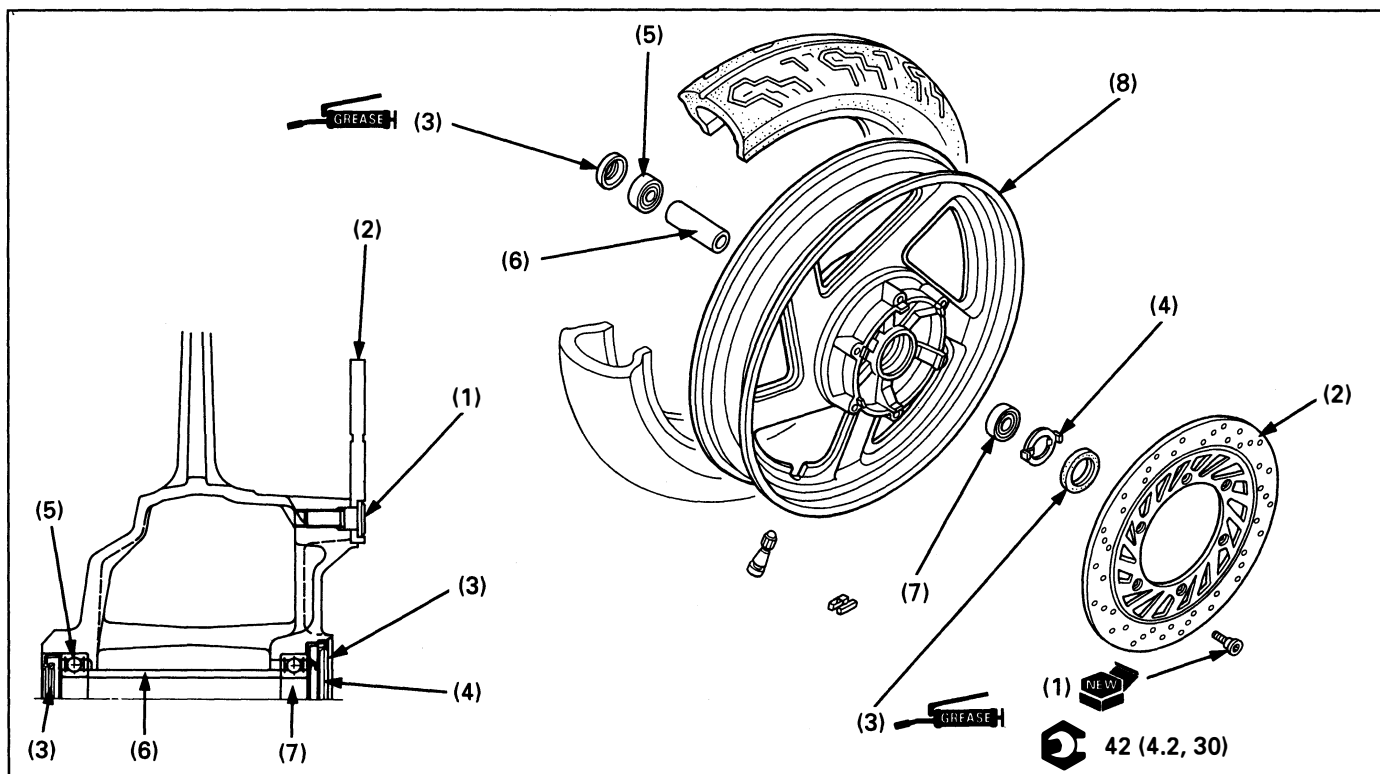

⚠ WARNING

- A contaminated brake disc or pad reduces stopping power. Discard contaminated pads and clean a contaminated disc with a high quality brake degreasing agent.

NOTE

- Always replace wheel bearings as a set.
- For wheel bearing replacement, refer to section 1 of the Common Service Manual.

Requisite Service

- Front wheel removal/installation (page 12-4)

Procedure	Q'ty	Remarks
Removal Order		Installation is in the reverse order of removal.
(1) Brake disc bolt	6	
(2) Brake disc	1	Install with stamped side outward.
(3) Dust seal	2	At installation, apply grease to the dust seal lips.
(4) Speedometer gear retainer	1	
(5) Right wheel bearing (6004 UU)	1	
(6) Distance collar	1	
(7) Left wheel bearing (6004 UU)	1	NOTE • At assembly, drive in the left side bearing first, then the right side bearing.
(8) Front wheel/tire	1/1	

Fork Removal/Installation

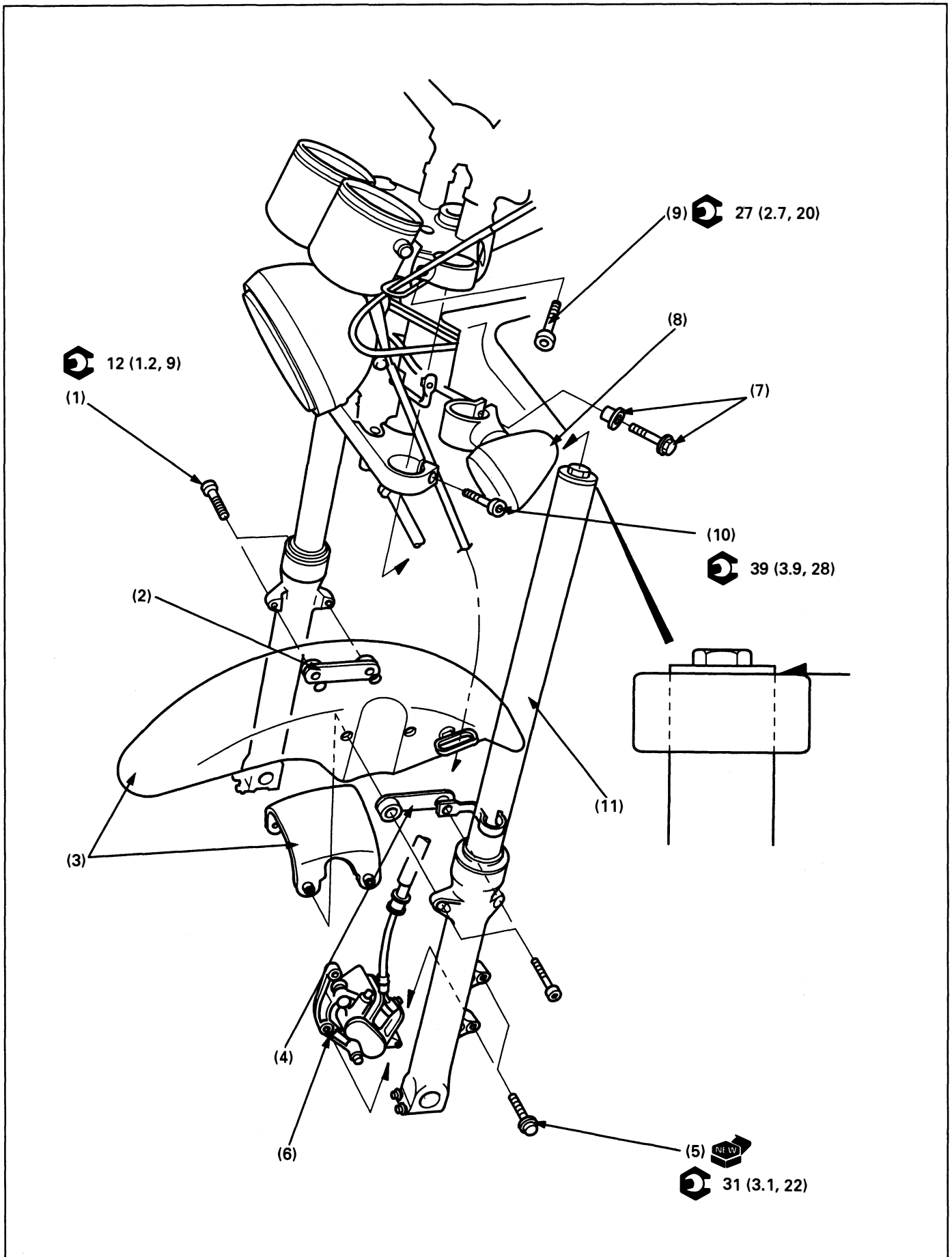

CAUTION

- Support the removed caliper so that it does not hang from the brake hose. Do not twist the brake hose.

NOTE

- If the fork legs will be disassembled, temporarily tighten the bottom bridge pinch bolt to loosen the fork cap.

Requisite Service

- Front wheel removal/installation (page 12-4)
- Upper fairing removal/installation (VF750CD: page 2-8)

Procedure		Q'ty	Remarks
	Removal Order		Installation is in the reverse order of removal.
(1)	Front fender bolt	4	
(2)	Front fender collar	1	
(3)	Front fender	1	
(4)	Brake hose clamp	1	
(5)	Caliper bracket bolt	2	
(6)	Caliper assembly	1	
(7)	Front turn signal bolt/collar	2/2	
(8)	Front turn signal assembly	2	
(9)	Fork pinch bolt (upper)	2	Only loosen the bolts.
(10)	Fork pinch bolt (lower)	2	• Only loosen the bolts. • If the fork leg will be disassembled, temporarily tighten the bottom pinch bolt to loosen the fork cap.
(11)	Fork assembly	2	At installation, align the tops of fork tubes with the upper surface of the top bridge.

Fork Disassembly

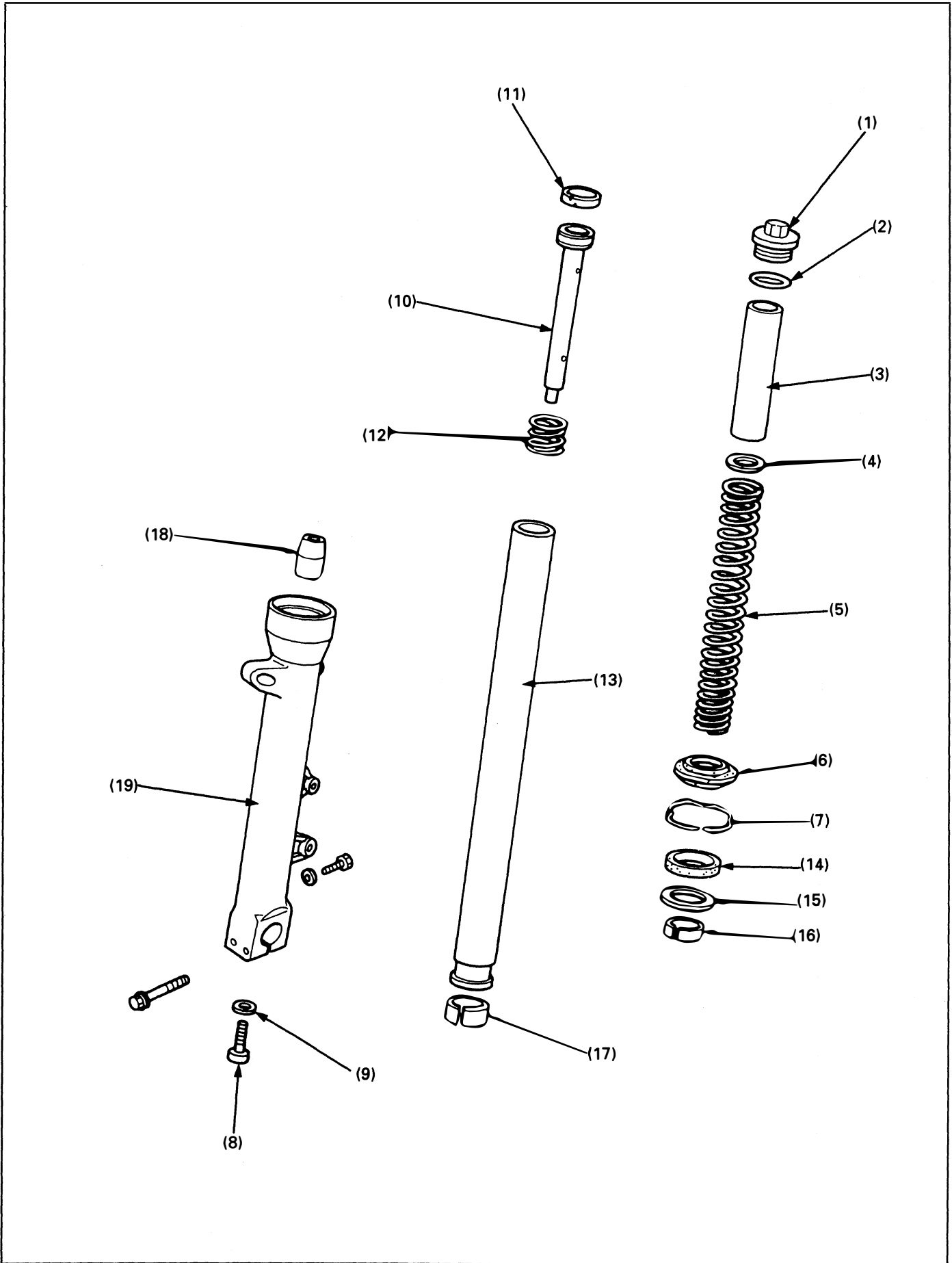

⚠ WARNING

- The fork cap is under spring pressure. Use care when removing it. Use face protection.

NOTE

- If the fork piston moves with the socket bolt during removal, temporarily install the spring, spacer and the fork cap.
- Always replace the oil seals with new ones.

Requisite Service

- Fork removal (page 12-6)

Procedure		Q'ty	Remarks
Disassembly Order			
(1)	Fork cap	1	
(2)	O-ring	1	
(3)	Spacer	1	
(4)	Spring seat	1	
(5)	Fork spring	1	After removing, pour out any remaining fork oil.
(6)	Dust seal	1	When removing, do not damage the fork tube.
(7)	Stopper ring	1	
(8)	Fork socket bolt	1	
(9)	Sealing washer	1	
(10)	Fork piston	1	
(11)	Fork piston ring	1	Do not remove it unless replacement is necessary.
(12)	Rebound spring	1	
(13)	Fork tube	1	
(14)	Oil seal	1	
(15)	Back up ring	1	
(16)	Slider bushing	1	
(17)	Fork tube bushing	1	Do not remove it unless replacement is necessary.
(18)	Oil lock piece	1	
(19)	Fork slider	1	

Fork Assembly

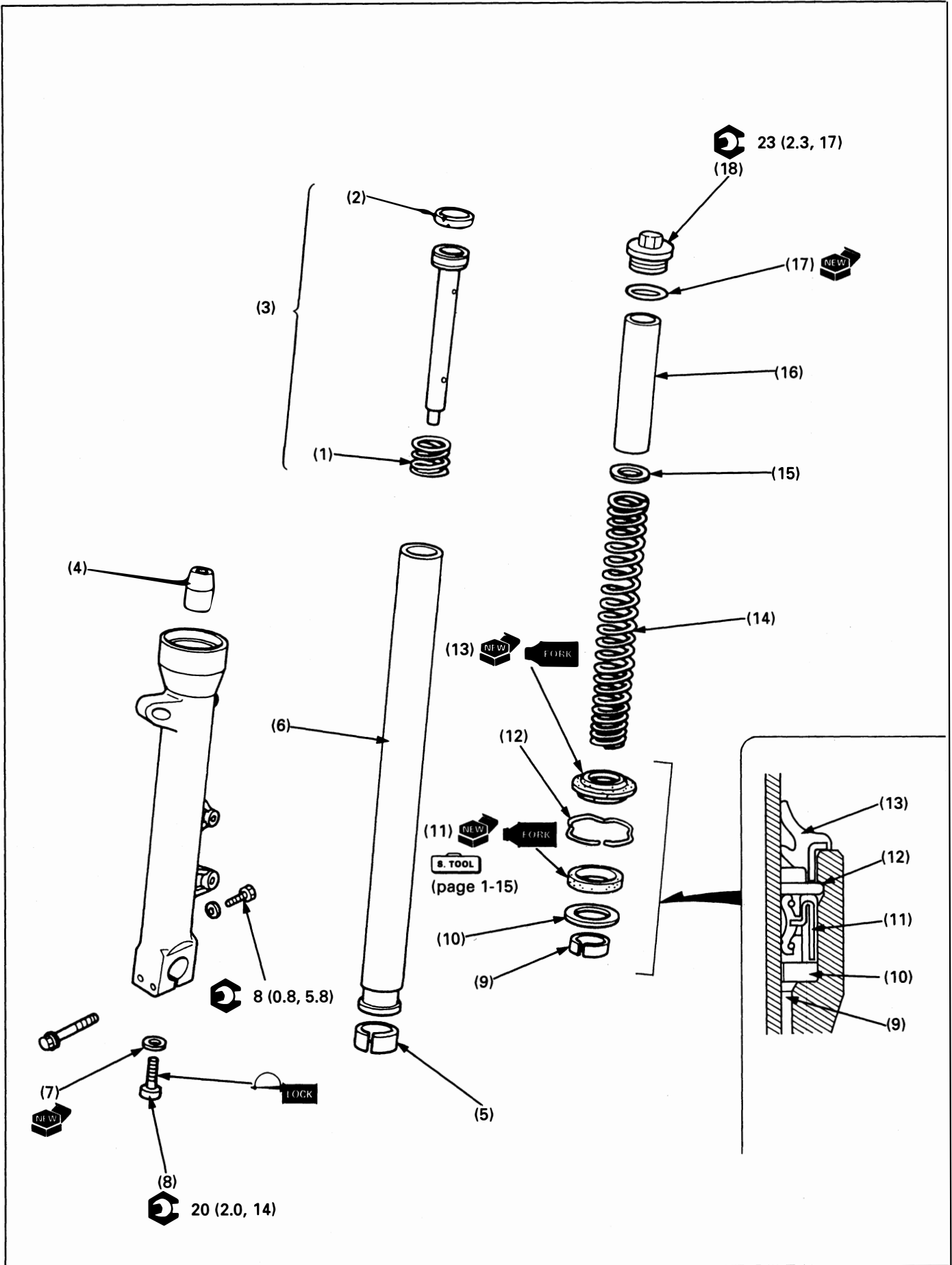

NOTE

- Always replace the oil seals with new ones.
- Coat the new oil seal with the recommended fork oil and install it with its mark facing up.
- After assembling the fork legs, install each fork leg into the lower fork bridge first, then torque the fork cap.

Requisite Service

- Fork disassembly (page 12-8)
- Fork installation (page 12-6)

Procedure		Q'ty	Remarks
	Assembly Order		
(1)	Rebound spring	1	
(2)	Fork piston ring	1	Replace with a new one if it was removed from the piston.
(3)	Fork piston assembly	1	Insert into the fork tube.
(4)	Oil lock piece	1	Insert onto the piston.
(5)	Fork tube bushing	1	Replace with a new one if it was removed from the fork tube.
(6)	Fork tube	1	
(7)	Sealing washer	1	
(8)	Fork socket bolt	1	If the socket bolt turns with the fork piston, temporarily install the fork spring, spacer and fork cap, then tighten the socket bolt.
(9)	Slider bushing	1	
(10)	Back up ring	1	
(11)	Oil seal	1	<ul style="list-style-type: none"> • Wrap vinyl tape around the fork tube top end to avoid damaging the oil seal during installation. • Use fork seal driver (07947 – KA50100) and attachment (07947 – KF00100) for fork seal installation.
(12)	Stopper ring	1	
(13)	Dust seal	1	After installing, compress the fork tube fully and pour the specified amount of fork fluid (page 1-10) into the fork tube.
(14)	Fork spring	1	Wipe all oil off the spring thoroughly using a clean, lint free cloth and install with the tapered end facing down.
(15)	Spring seat	1	
(16)	Spacer	1	
(17)	O-ring	1	Apply oil to the new O-ring.
(18)	Fork cap	1	<p>CAUTION</p> <ul style="list-style-type: none"> • Be careful not to cross-thread the fork cap. • Screw in the cap, but do not tighten yet.

Steering Stem Removal/Installation

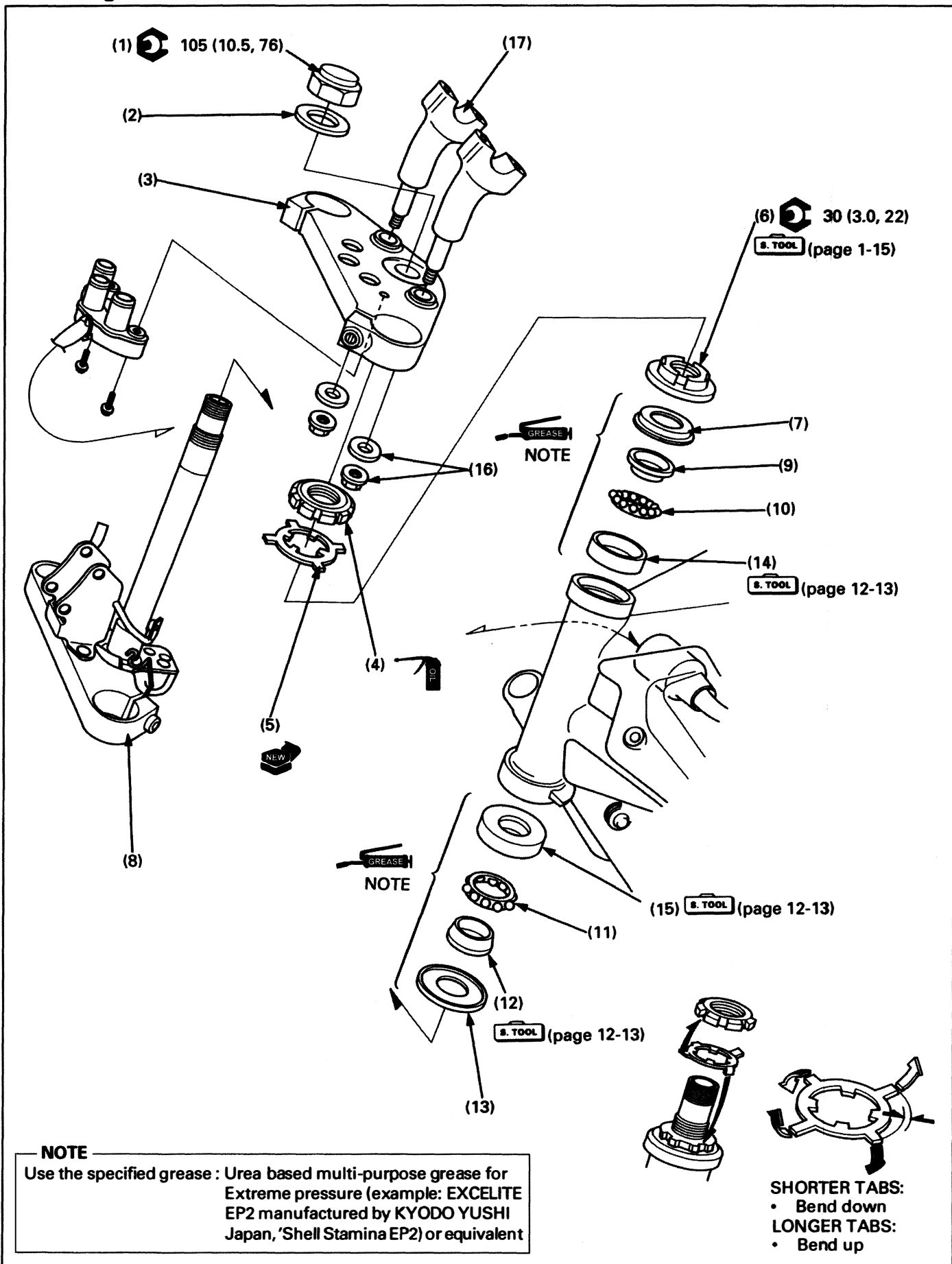

NOTE

- Replace the bearings and races as a set.
- At installation, apply grease to all bearing area.
- Check the steering head bearing preload (page 1-10) after torquing the stem nut.

Requisite Service

- Fork removal/installation (page 12-6)
- Handlebar removal/installation (page 12-2)
- Meter removal/installation (page 18-7)
- Headlight removal/installation (page 18-6)

Procedure		Q'ty	Remarks		
Removal Order					
(1)	Steering stem nut	1	After removing, remove the fork.		
(2)	Thrust washer	1			
(3)	Top bridge	1	Remove, after straightening the lock washer tabs.		
(4)	Lock nut	1			
(5)	Lock washer	1			
(6)	Steering head bearing adjustment nut	1			
(7)	Dust seal	1			
(8)	Steering stem	1			
(9)	Upper bearing inner race	1			
(10)	Upper bearing	1			
(11)	Lower bearing	1			
(12)	Lower bearing inner race	1		Replace if removed.	
(13)	Dust seal	1			
(14)	Upper bearing outer race	1			• Use race remover attachment (07953 – MJ10100 or 07953 – MJ1000A [U.S.A. only]) with driver (07953 – MJ10200 or M9360 – 277 – 91774 [U.S.A. only]) for upper outer race removal.
(15)	Lower bearing outer race	1			
(16)	Lower holder nut/washer	2/2			
(17)	Lower holder	2			
Installation Oder					
(17)	Lower holder	2	Tightening procedure (page 12-14). Replace as a set, if necessary. • Use attachment, 52 x 55 mm (07746 – 0010400) and driver (07749 – 0010000) for lower outer race installation. • Use attachment, 42 x 47 mm (07746 – 0010300) and driver (07749 – 0010000) for upper outer race installation. • Use steering stem driver (07946 – MB00000) for lower inner race installation.		
(16)	Lower holder nut/washer	2/2			
(15)	Lower bearing outer race	1			
(14)	Upper bearing outer race	1			
(13)	Dust seal.	1			
(12)	Lower bearing inner race	1			
(11)	Lower bearing	1			
(10)	Upper bearing	1			
(9)	Upper bearing inner race	1			
(8)	Steering stem	1			
(7)	Dust seal	1			
(6)	Steering head bearing adjustment nut	1		Installation: refer to section 18 of the Common Service Manual (Retainer-Type Ball Bearings).	
(5)	Lock washer	1			
(4)	Lock nut	1			
(3)	Top bridge	1			
(2)	Thrust washer	1			
(1)	Steering stem nut	1		Temporarily install fork and torque the nut.	

Front Wheel/Suspension/Steering

Handlebar Lower Holder Nut Tightening Procedure

Install the handlebar lower holder.

Loosely install the washers and nuts.

Install the handlebar and upper holder (page 12-2).

Tighten the upper holder bolts.

Torque: 5 N·m (0.5 kg·m, 3.6 ft·lb)

Adjust the handlebar straight-ahead by tap the end of handlebar. Make sure that the length A and B are equal.

Tighten the lower holder nuts.

Torque: 27 N·m (2.7 kg·m, 20 ft·lb)

Tighten the upper holder bolts (page 12-2).

Torque: 23 N·m (2.3 kg·m, 17 ft·lb)

Make sure that the length A and B are equal.

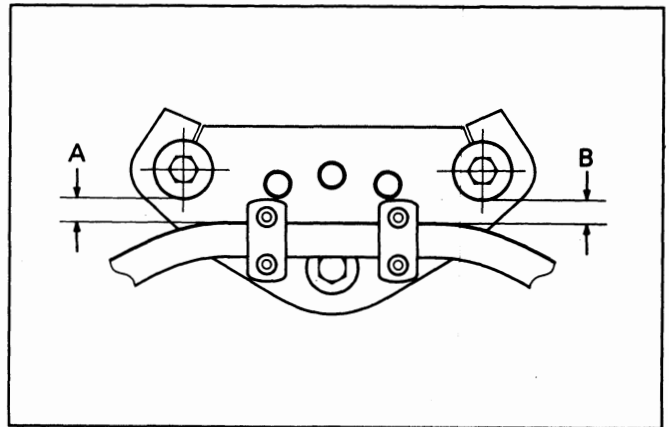
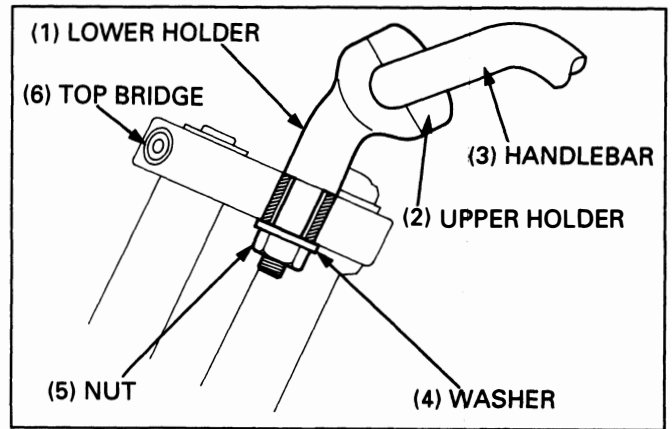

13. Rear Wheel/Suspension

Service Information	13-1	Shock Absorber Removal/Installation	13-6
Troubleshooting	13-1	Shock Absorber Disassembly/Assembly	13-7
Rear Wheel Removal/Installation	13-2	Swingarm Removal/Installation	13-9
Rear Wheel Disassembly/Assembly	13-4	Swingarm Disassembly/Assembly	13-11

Service Information

▲ WARNING

- **Inhaled asbestos fibers have been found to cause respiratory disease and cancer. Never use an air hose or dry brush to clean brake assemblies. Use an OSHA-approved vacuum cleaner or alternate method approved by OSHA, designed to minimize the hazard caused by airborne asbestos fibers.**
 - **A contaminated brake drum or shoe reduces stopping power. Discard contaminated shoes and clean a contaminated drum with a high quality brake degreasing agent.**
 - **Any attempt to mount automobile tires on a motorcycle rim may cause the tire bead to separate from the rim with enough explosive force to cause serious injury or death.**
- When servicing the rear wheel, support the motorcycle using a safety stand or hoist.
 - Refer to the section 14 for brake system information.
 - Tubeless tire removal, repair, and remounting procedures are covered in the section 16 of the Common Service Manual.

Troubleshooting

Soft Suspension

- Weak spring
- Oil leakage from damper unit
- Incorrect suspension adjustment
- Low tire pressure

Hard Suspension

- Incorrectly suspension adjustment
- Bent swingarm pivot
- Damaged swingarm pivot bearings
- Bent damper rod
- High tire pressure

Steers To One Side Or Does Not Track Straight

- Bent rear axle
- Axle alignment/chain adjustment not equal on both sides

Rear Wheel Wobbling

- Bent rim
- Worn rear wheel bearings
- Faulty tire
- Unbalanced tire and wheel
- Low tire pressure
- Faulty swingarm pivot bearings

Rear Wheel Removal/Installation

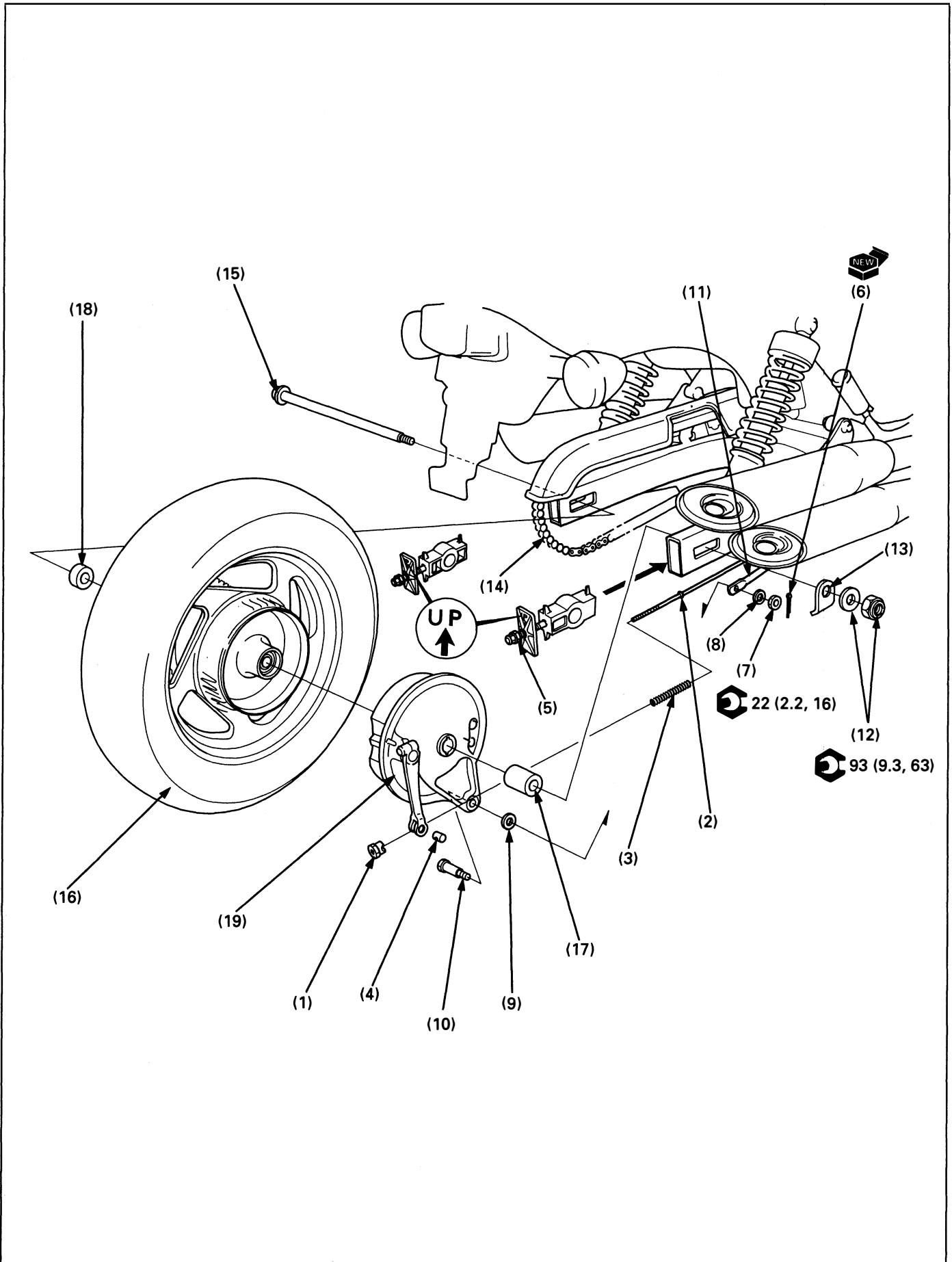

⚠ WARNING

- Inhaled asbestos fibers have been found to cause respiratory disease and cancer. Never use an air hose or dry brush to clean brake assemblies. Use an OSHA-approved vacuum cleaner or alternate method approved by OSHA designed to minimize the hazard caused by airborne asbestos fibers.
- A contaminated brake drum or shoe reduces stopping power. Discard contaminated shoe and clean a contaminated drum with a high quality brake degreasing agent.

NOTE

- When servicing the rear wheel, support the motorcycle using a safety stand or hoist.
- Adjust the drive chain free play after installing the wheel.
- Apply thin layer of grease to the rear axle surface.

Procedure		Q'ty	Remarks
	Removal Order		Installation is in the reverse order of removal.
(1)	Brake adjusting nut	1	
(2)	Brake rod	1	
(3)	Spring	1	
(4)	Brake rod joint piece	1	
(5)	Drive chain adjusting nut	2	Loosen the adjusting nut fully.
(6)	Cotter pin	1	
(7)	Nut	1	
(8)	Washer	1	
(9)	Rubber cushion	1	
(10)	Brake stopper arm pivot bolt	1	
(11)	Brake stopper arm	1	
(12)	Rear axle nut/washer	1/1	
(13)	Drive chain adjuster	1	
(14)	Drive chain	1	Move the rear wheel forward and remove the drive chain from the driven sprocket.
(15)	Rear axle	1	
(16)	Rear wheel assembly	1	
(17)	Right side collar	1	
(18)	Left side collar	1	
(19)	Brake panel assembly	1	Disassembly (page 14-7).

Rear Wheel Disassembly/Assembly

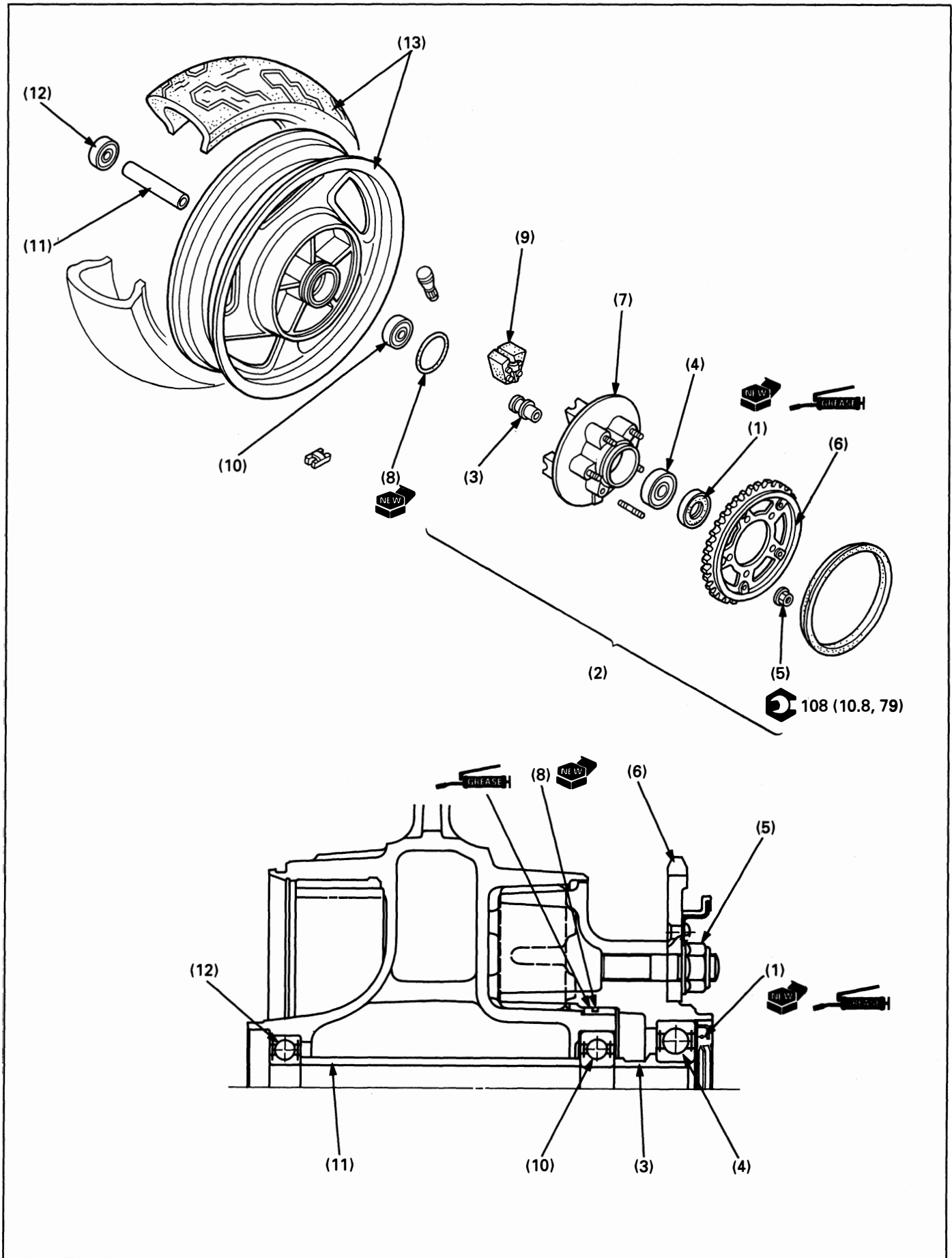

▲ WARNING

- **Inhaled asbestos fibers have been found to cause respiratory disease and cancer. Never use an air hose or dry brush to clean brake assemblies. Use an OSHA-approved vacuum cleaner or alternate method approved by OSHA designed to minimize the hazard caused by airborne asbestos fibers.**
- **A contaminated brake drum or shoe reduces stopping power. Discard contaminated shoes and clean contaminated drums with a high quality brake degreasing agent.**

NOTE

- For driven sprocket removal, loosen the sprocket nuts with the driven flange installed into the wheel hub.
- Replace wheel bearings as a set.
- For wheel bearing replacement, refer to the section 1 of the Common Service Manual.

Requisite Service

- Rear wheel removal/installation (page 13-2)

Procedure		Q'ty	Remarks
(1)	Disassembly Order Dust seal	1	Assembly is in the reverse order of disassembly. At assembly, apply grease to the dust seal lips.
(2)	Driven Flange Disassembly Order Driven flange assembly	1	
(3)	— Driven flange collar	1	
(4)	— Driven flange bearing (6305 UU)	1	
(5)	— Driven sprocket nut	5	
(6)	— Driven sprocket	1	
(7)	— Driven flange	1	
(8)	O-ring	1	
(9)	Rear wheel damper	5	
(10)	Left wheel bearing (6304 UU)	1	
(11)	Distance collar	1	
(12)	Right wheel bearing (6204 UU)	1	Drive in the right side bearing first, then the left side bearing.
(13)	Rear wheel/tire	1/1	

Shock Absorber Removal/Installation

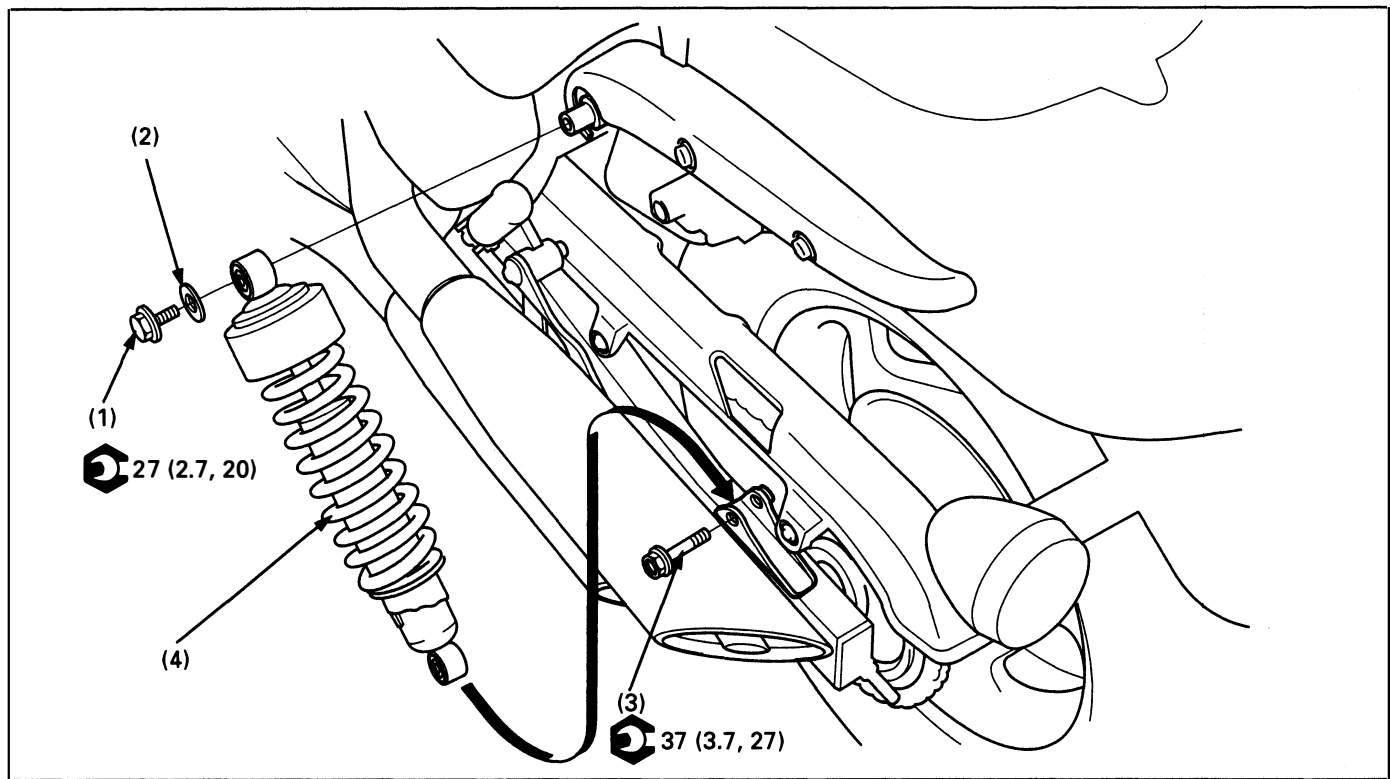

NOTE

- When servicing the shock absorber, support the motorcycle using a safety stand or hoist.
- Adjust the shock absorber to the softest position for disassembly.

Procedure		Q'ty	Remarks
	Removal Order		Installation is in the reverse order of removal.
(1)	Shock absorber mounting bolt (upper)	1	NOTE • Move the muffler outside, remove the mounting bolt.
(2)	Plain washer	1	
(3)	Shock absorber mounting bolt (lower)	1	
(4)	Shock absorber assembly	1	

Shock Absorber Disassembly/Assembly

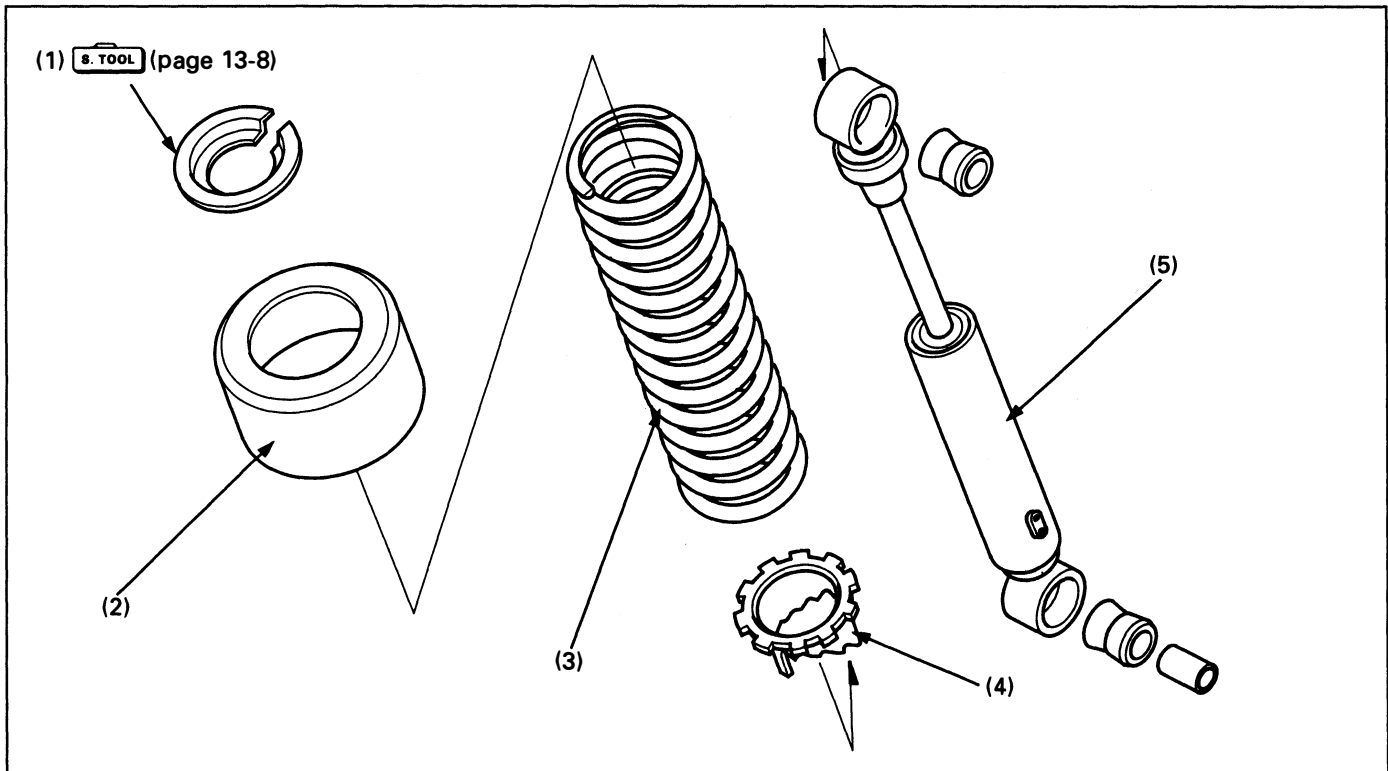

Requisite Service

- Rear shock absorber removal/installation (page 13-6)

Procedure		Q'ty	Remarks
Disassembly Order			Assembly is in the reverse order of disassembly. See page 13-8.
(1)	Upper seat	1	
(2)	Spring cover	1	
(3)	Spring	1	Install the spring with the small coil end toward the bottom.
(4)	Preload adjuster	1	
(5)	Damper unit assembly	1	

Rear Wheel/Suspension

Spring, Upper Seat Removal/Installation

Install the shock absorber compressor on the shock absorber.

S. TOOL

Shock absorber compressor 07959 - 3290001

Compress the shock absorber spring and remove the upper seat.

CAUTION

- Do not compress the spring more than necessary.

Loosen the shock absorber compressor slowly and remove the shock absorber. Remove the spring cover and shock absorber spring.

Install the spring with the small coil end toward the bottom.

Install the spring cover.

Install the special tools and compress the shock absorber spring. Install the spring seat securely.

S. TOOL

Shock absorber compressor 07959 - 3290001

Loosen the shock absorber compressor slowly and remove the shock absorber.

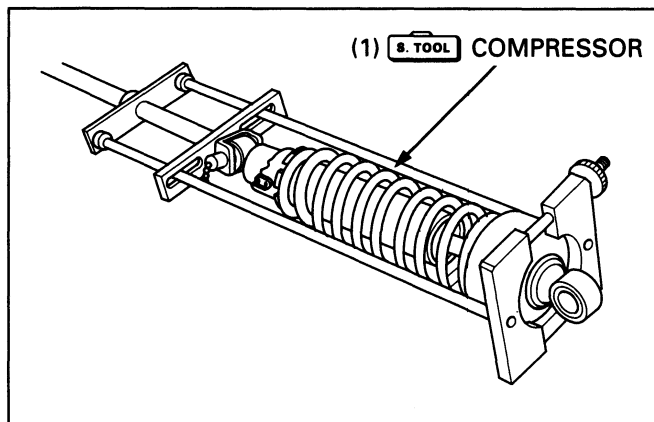
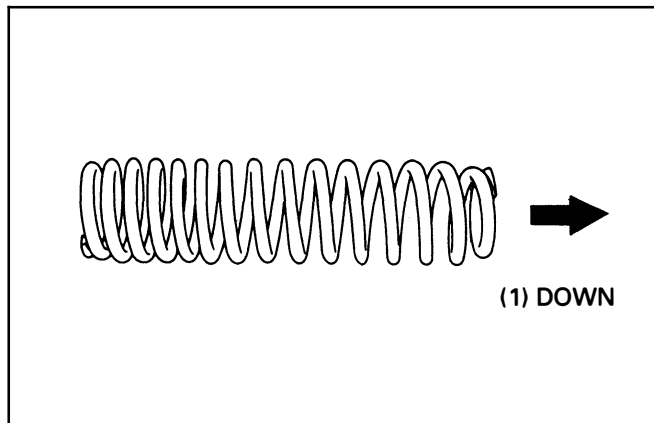
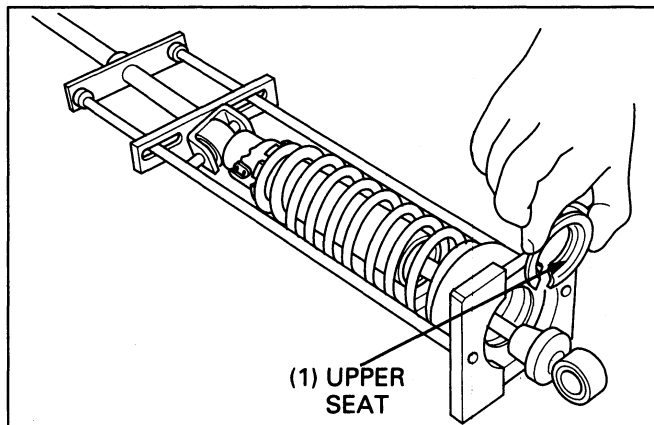
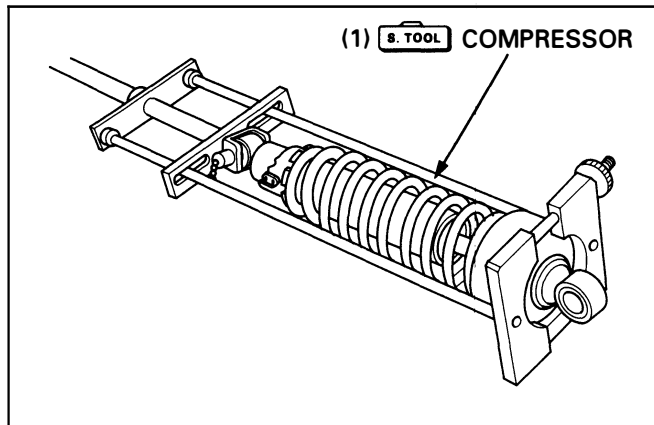

Swingarm Removal/Installation

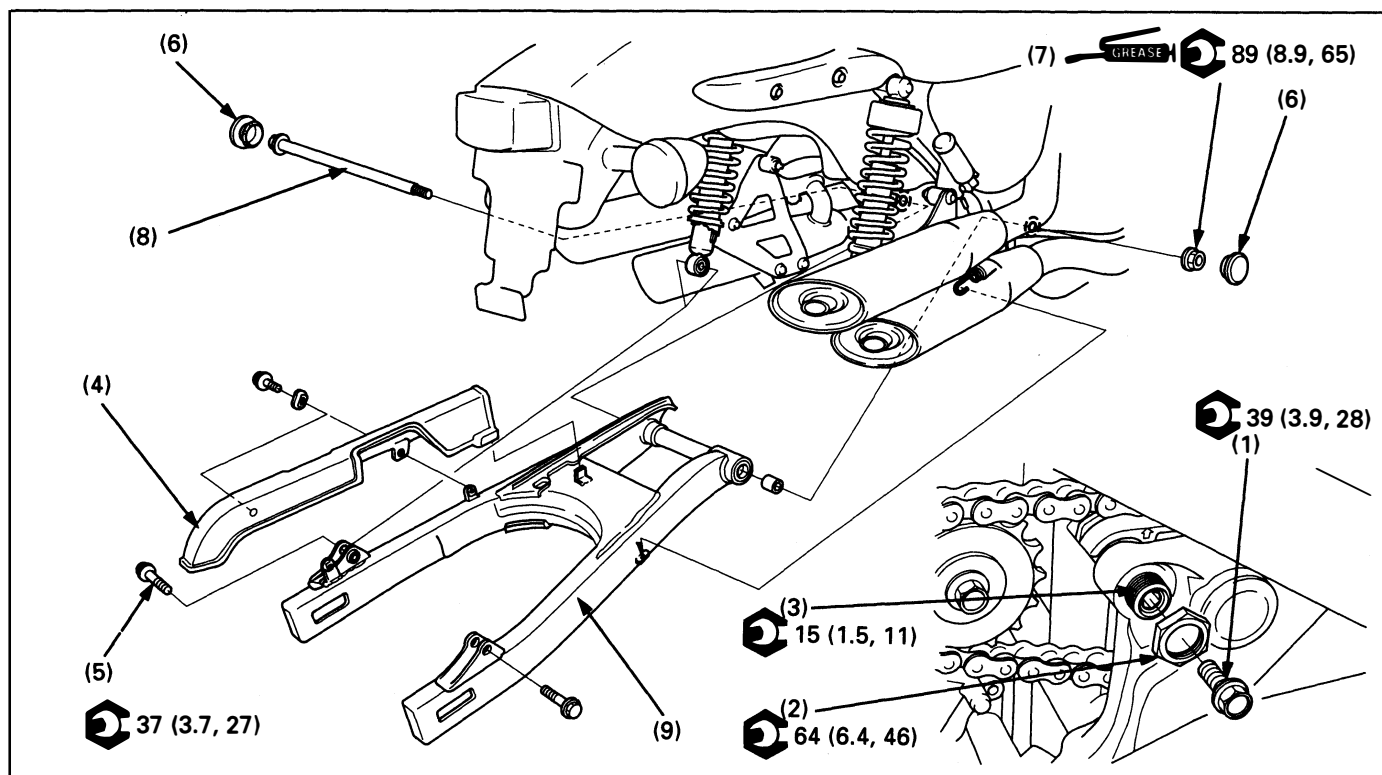

Requisite Service

- Rear wheel removal/installation (page 13-2)
- Drive sprocket cover removal/installation (page 10-2)

Procedure	Q'ty	Remarks
Removal Order		Installation is in the reverse order of removal.
(1) Frame pivot lock bolt	1	Adjustment (page 13-10)
(2) Frame pivot lock nut	1	
(3) Frame pivot adjusting bolt	1	
(4) Drive chain cover	1	
(5) Shock absorber lower mounting bolt	2	NOTE • Move the muffler outside, remove the mounting bolts.
(6) Cap	2	
(7) Swingarm pivot nut	1	
(8) Swingarm pivot bolt	1	
(9) Swingarm assembly	1	

Frame Pivot Adjusting Bolt Adjustment

Removal

Remove the pivot lock bolt.
Remove the adjusting bolt lock nut.

NOTE

- Remove the lock nut while holding the adjusting bolt.

Remove the adjusting bolt.

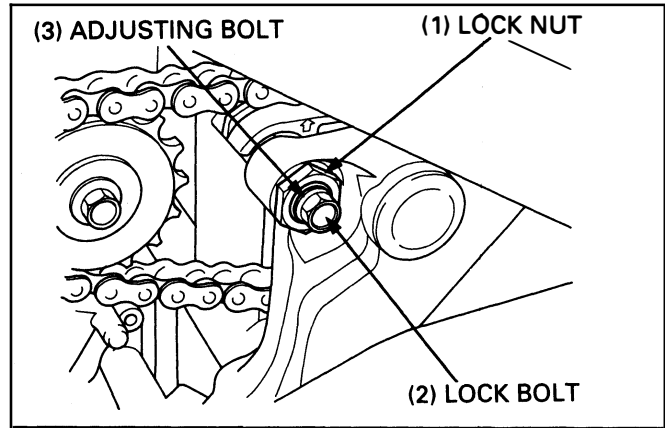

Installation

Tighten the adjusting bolt.

Torque: 15 N·m (1.5 kg·m, 11 ft·lb)

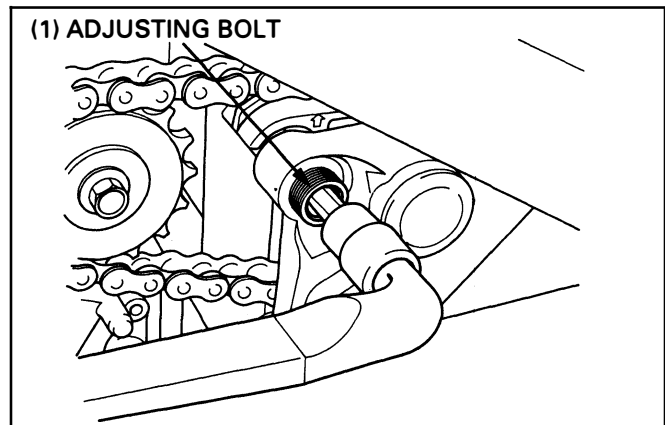

Tighten the lock nut while holding the adjusting bolt.

Torque: 64 N·m (6.4 kg·m, 46 ft·lb)

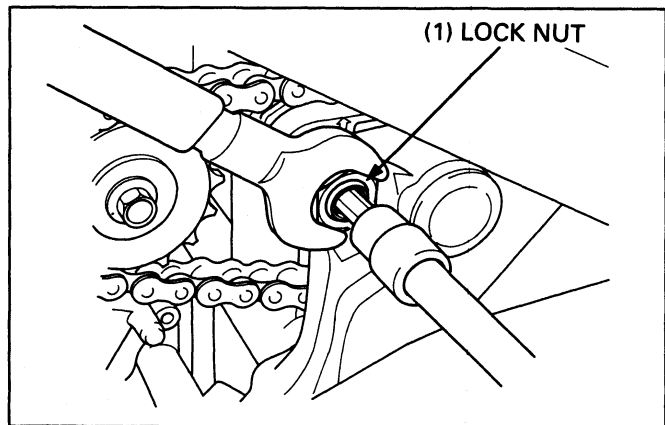

Tighten the pivot lock bolt.

Torque: 39 N·m (3.9 kg·m, 28 ft·lb)

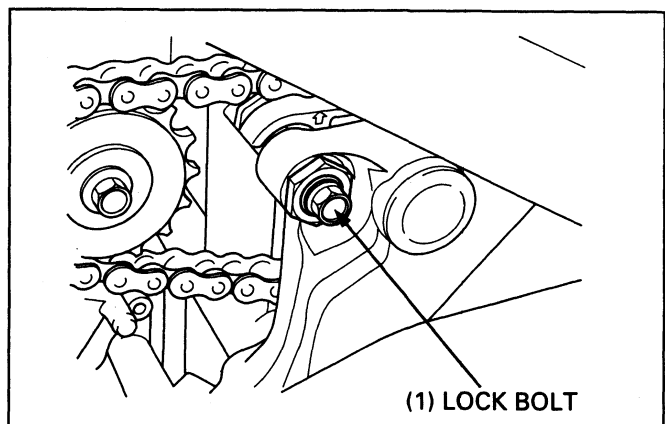

Swingarm Disassembly/Assembly

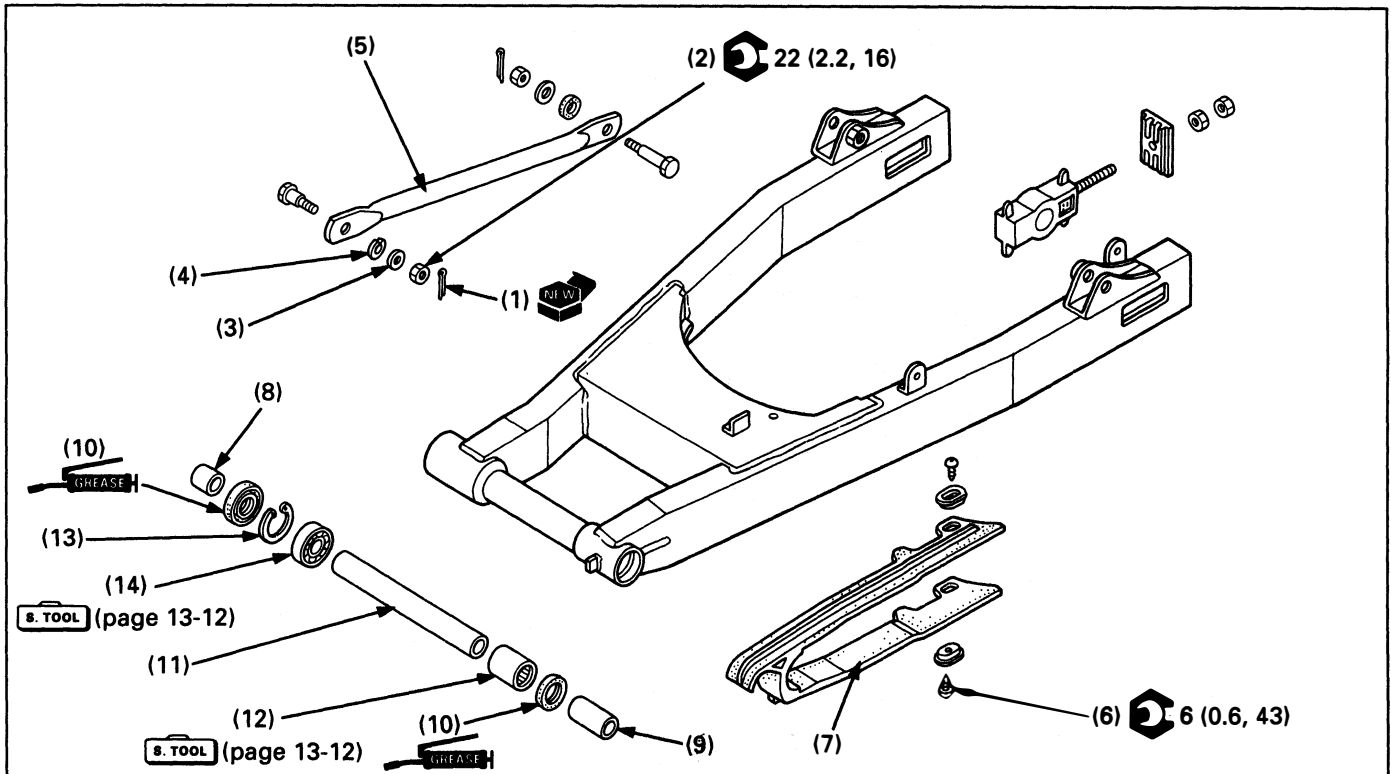

NOTE

- For pivot bearing replacement, see next page.

Requisite Service

- Swing arm removal/installation (page 13-9)

Procedure	Q'ty	Remarks
Disassembly Order		Assembly is in the reverse order of disassembly.
(1) Cotter pin	1	
(2) Nut	1	
(3) Plain washer	1	
(4) Rubber cushion	1	
(5) Brake stopper arm	1	
(6) Drive chain slider screw	2	
(7) Drive chain slider	1	
(8) Right pivot collar	1	
(9) Left pivot collar	1	
(10) Dust seal	2	Apply grease to the lip.
(11) Distance collar	1	
(12) Needle bearing	1	
(13) Snap ring	1	Install it into the groove securely.
(14) Ball bearing	1	

Rear Wheel/Suspension

Swingarm Pivot Bearing Replacement

Press the right pivot bearing (ball bearing) out of swingarm.

S. TOOL

Driver Shaft

**07946 - MJ00100 or
07949 - 3710001
(U.S.A. only)**

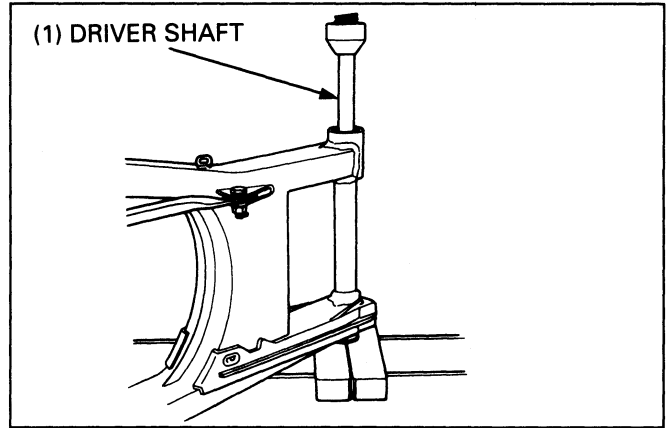

Set the needle bearing remover attachment onto the left pivot bearing (needle bearing) as shown.

S. TOOL

Needle bearing remover attachment

Driver Shaft

or (U.S.A. only):

Bearing remover

Driver

Pilot, 15 mm

Attachment, 30 mm

**07GMD - KT70200
07946 - MJ00100**

M967X - 038 - XXXX

07949 - 3710001

07746 - 0040300

07746 - 0030300

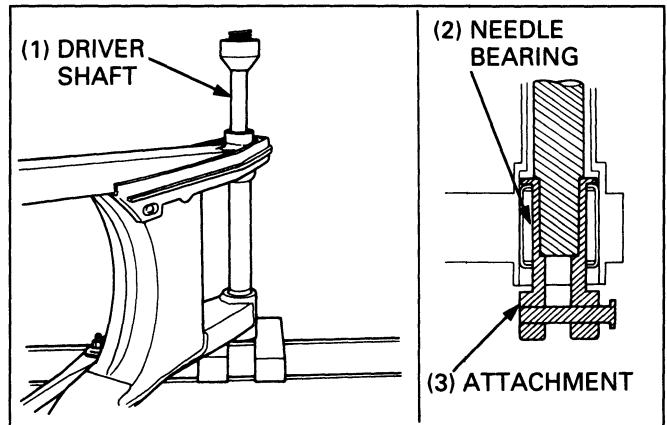

Press the needle bearing into the swingarm with the marked side facing out.

NOTE

- The bearing surface should be flush with the pivot inside surface as shown.

S. TOOL

Driver

Attachment, 28 x 30 mm

Pilot, 22 mm

07749 - 0010000

07946 - 1870100

07746 - 0041000

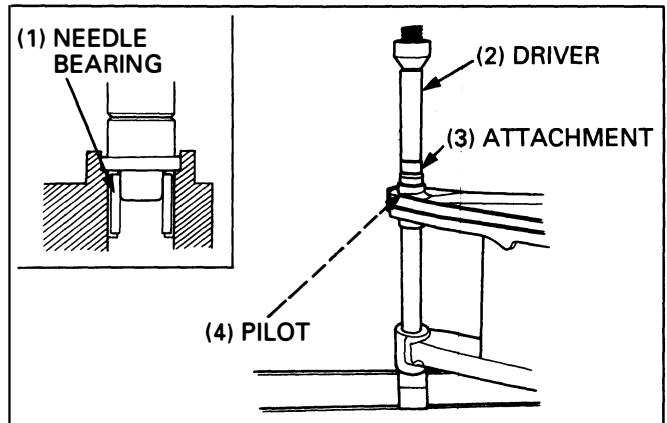

Press the ball bearing in until it bottoms in the swingarm.

S. TOOL

Driver

Attachment, 32 x 35 mm

Pilot, 15 mm

07749 - 0010000

07746 - 0010100

07746 - 0040300

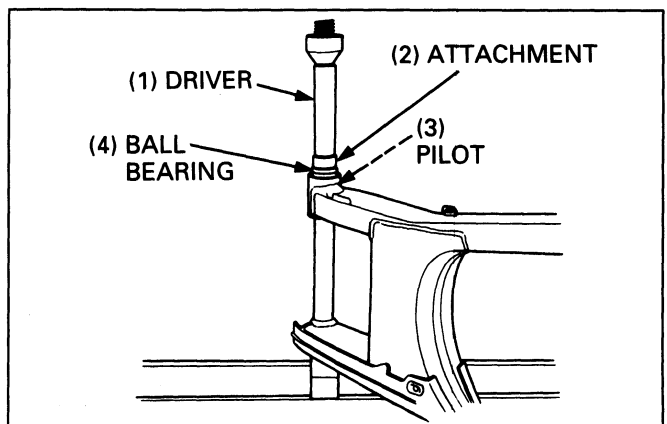

14. Brake System

Service Information	14-1	Front Master Cylinder Removal/ Installation	14-5
Troubleshooting	14-1		
Front Brake Pad Replacement	14-2	Front Master Cylinder Disassembly/ Assembly	14-6
Front Brake Caliper Removal/ Installation	14-3	Rear Brake Panel Disassembly/ Assembly	14-7
Front Brake Caliper Disassembly/ Assembly	14-4	Brake Pedal Removal/Installation	14-8

Service Information

⚠ WARNING

- Inhaled asbestos fibers have been found to cause respiratory disease and cancer. Never use an air hose or dry brush to clean brake assemblies. Use an OSHA-approved vacuum cleaner or alternate method approved by OSHA designed to minimize the hazard caused by airborne asbestos fibers.
- A contaminated brake disc, drum, pad or shoe reduces stopping power. Discard contaminated pads/shoes and clean a contaminated disc/drum with a high quality brake degreasing agent.
- Spilled brake fluid will severely damage instrument lenses and painted surfaces. It is also harmful to some rubber parts. Be careful whenever you remove the reservoir cap: make sure the reservoir is horizontal first.
- Never allow contaminants (dirt, water, etc.) to get into an open reservoir.
- Once the hydraulic system has been opened, or if the brake feel spongy, the system must be bled.
- Always use fresh DOT 4 brake fluid from a sealed container when servicing the system. Do not mix different types of fluid as they may not be compatible.
- Always check brake operation before riding the motorcycle.

Troubleshooting

Front Brake:

Brake Lever Soft Or Spongy

- Air bubbles in the hydraulic system
- Leaking hydraulic system
- Contaminated brake pad/disc
- Worn caliper piston seal
- Worn master cylinder piston seal
- Worn brake pad/disc
- Contaminated caliper
- Caliper not sliding properly
- Low fluid level
- Clogged fluid passage
- Warped/deformed brake disc
- Sticking/worn caliper piston
- Sticking/worn master cylinder piston
- Contaminated master cylinder

Rear brake:

Poor Brake Performance

- Improperly adjusted brake
- Worn brake linings
- Worn brake drum
- Worn brake cam
- Improperly installed brake linings
- Brake linkage needs lubrication
- Contaminated brake linings
- Contaminated brake drum
- Worn brake shoes at cam contact area
- Improper engagement between brake arm and cam serrations

Brake Lever Hard

- Clogged/restricted brake system
- Sticking/worn caliper piston
- Caliper not sliding properly
- Clogged/restricted fluid passage
- Worn caliper piston seal
- Sticking/worn master cylinder piston
- Bent brake lever

Brakes Drag

- Contaminated brake pad/disc
- Misaligned wheel
- Worn brake pad/disc
- Warped/deformed brake disc
- Caliper not sliding properly

Brake Pedal Hard Or Slow Return

- Worn/broken return spring
- Improperly adjusted brake
- Sticking brake drum due to contamination
- Worn brake shoes at cam contact area
- Brake linkage needs lubrication
- Improperly installed brake linings

Brake Squeaks

- Worn brake linings
- Worn brake drum
- Contaminated brake linings
- Contaminated brake drum

Front Brake Pad Replacement

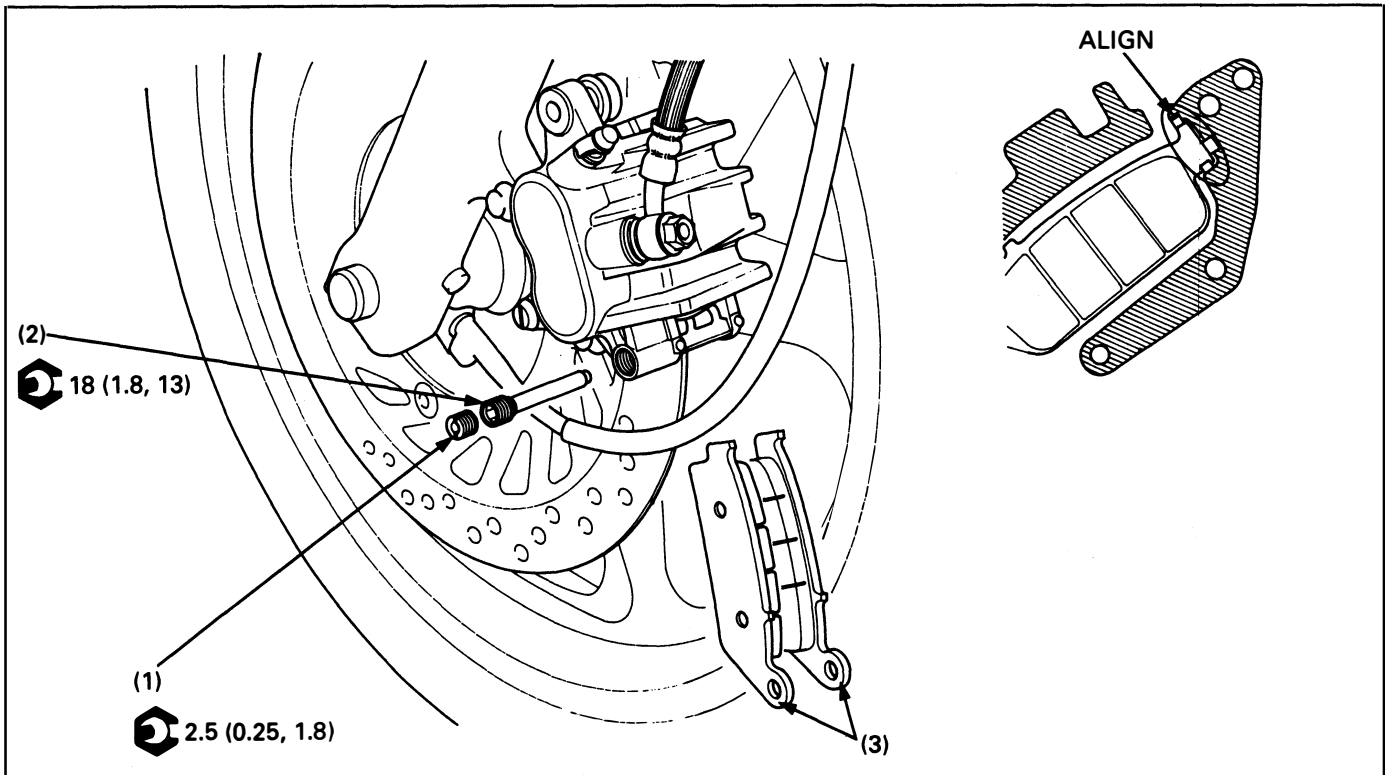

⚠ WARNING

- A contaminated brake disc or pad reduces stopping power. Discard contaminated pads and clean a contaminated disc with a high quality brake degreasing agent.
- Check the brake system by applying the brake after the pad replacement.

NOTE

- Operate the brake lever to seat the caliper pistons against the pads after the pad replacement.
- The brake pad replacement can be done without disconnecting the hydraulic system.
- Always replace the brake pads in pairs to assure even disc pressure.

	Procedure	Q'ty	Remarks
	Removal Order		Installation is in the reverse order of removal.
(1)	Pad pin plug	1	After removing the pad pin plug, loosen the pad pin.
(2)	Pad pin	1	Insert the pin, pushing the pads against the pad spring.
(3)	Brake pad	2	At installation, position the pad onto the pad retainer in the caliper as shown.

Front Brake Caliper Removal/Installation

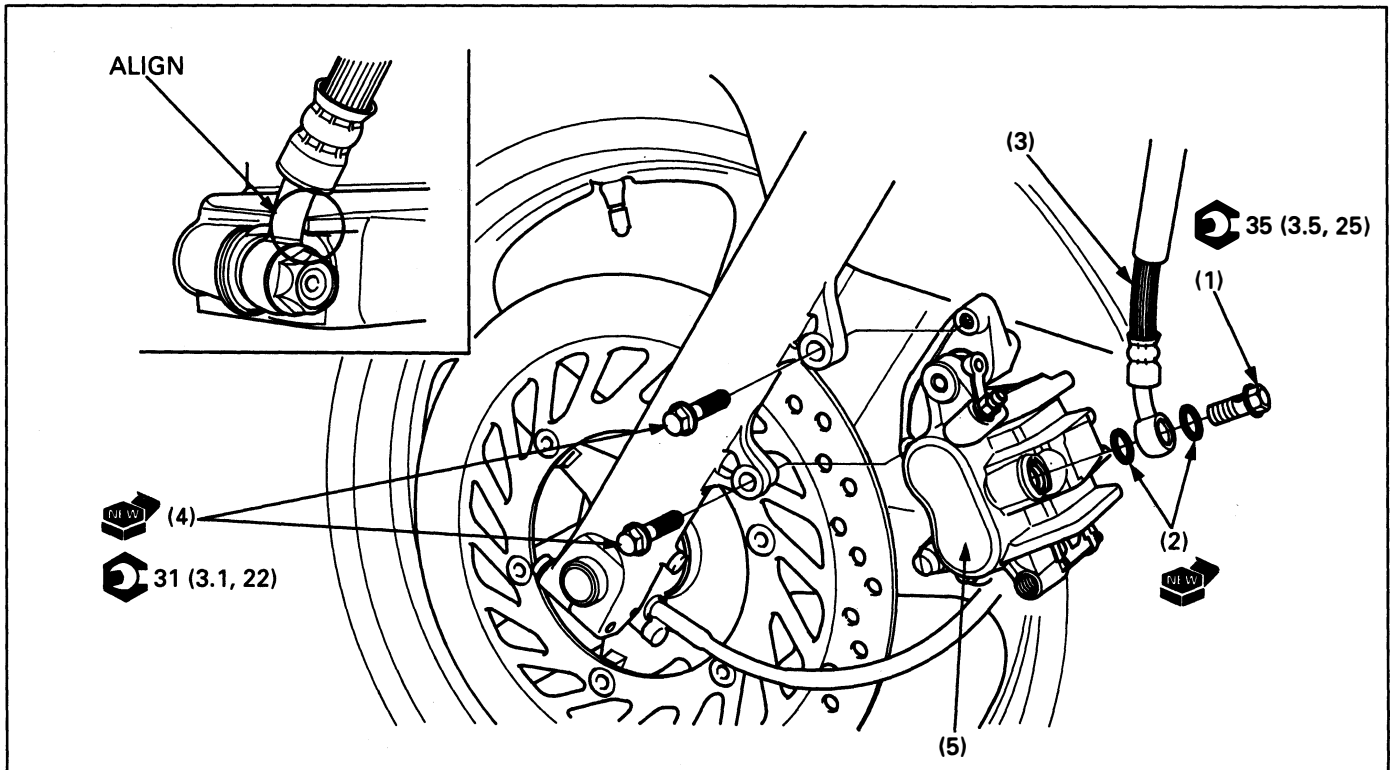

WARNING

- A contaminated brake disc or pad reduces stopping power. Discard contaminated pads and clean a contaminated disc with a high quality brake degreasing agent.
- Check the brake system by applying the brake after bleeding air from the system.

CAUTION

- Avoid spilling brake fluid on painted, plastic, or rubber parts. Place a rag over these parts whenever the system is serviced.

Requisite Service

- Front brake pad replacement (page 14-2)
- Brake fluid replacement/air bleeding (Section 17 of the Common Service Manual)

Procedure	Q'ty	Remarks
Removal Order		Installation is in the reverse order of removal.
(1) Brake hose bolt	1	At installation, press the brake hose end against the stopper while tightening the hose bolt.
(2) Sealing washer	2	
(3) Brake hose eyelet joint	1	
(4) Caliper bracket bolt	2	
(5) Front brake caliper assembly	1	

Front Brake Caliper Disassembly/Assembly

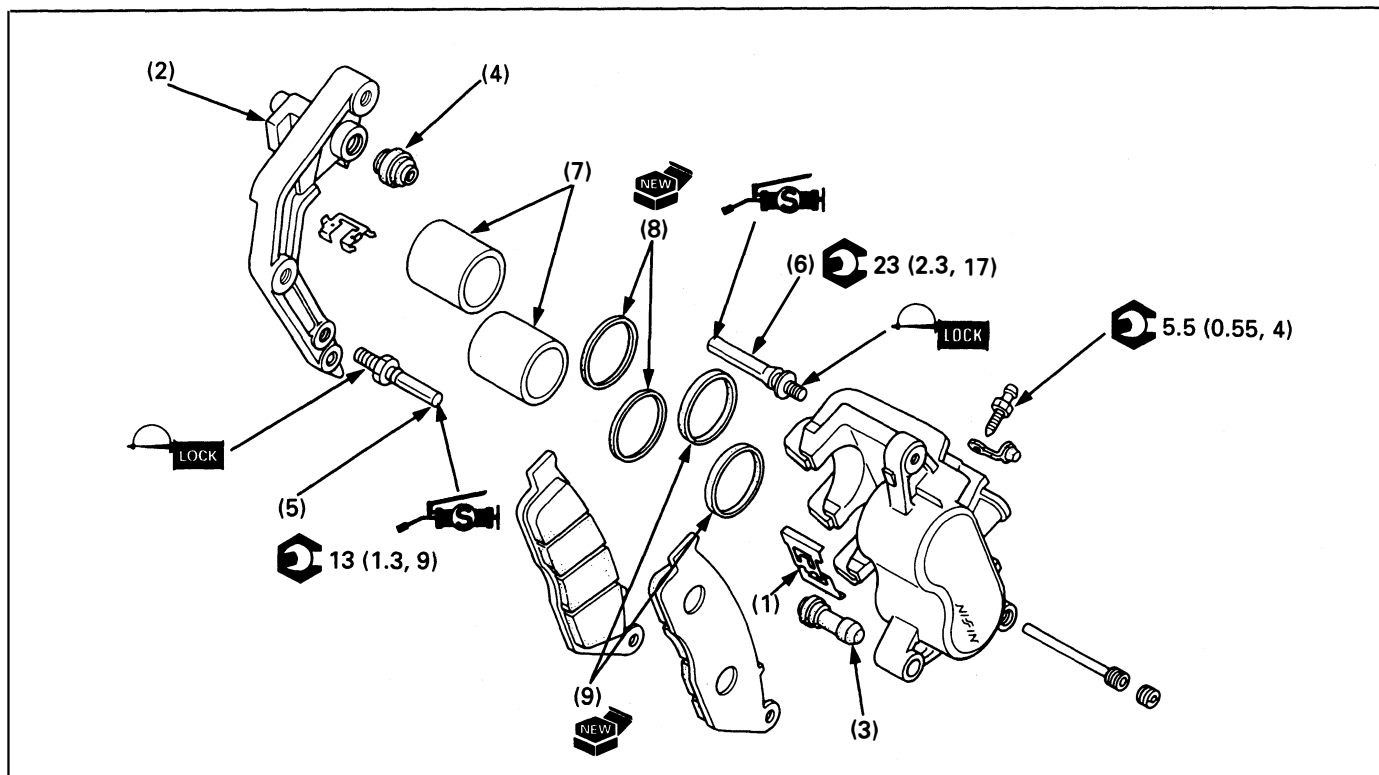

CAUTION

• Avoid spilling brake fluid on painted, plastic, or rubber parts. Place a rag over these parts whenever the system is serviced.

Requisite Service

- Front brake caliper removal/installation (page 14-3)

Procedure	Q'ty	Remarks
Disassembly Order		Assembly is in the reverse order of disassembly. Note spring direction as shown.
(1) Pad spring	1	
(2) Caliper bracket	1	
(3) Bracket pin bolt boot	1	
(4) Caliper pin bolt boot	1	Install into the bracket groove securely.
(5) Bracket pin bolt	1	At installation, apply a locking agent to the threads.
(6) Caliper pin bolt	1	At installation, apply a locking agent to the threads.
(7) Caliper piston	2	At installation, install the piston with the dished end toward the caliper.
(8) Dust seal	2	CAUTION • Be careful not to damage the piston sliding surface when removing the seals.
(9) Piston seal	2	

Front Master Cylinder Removal/Installation

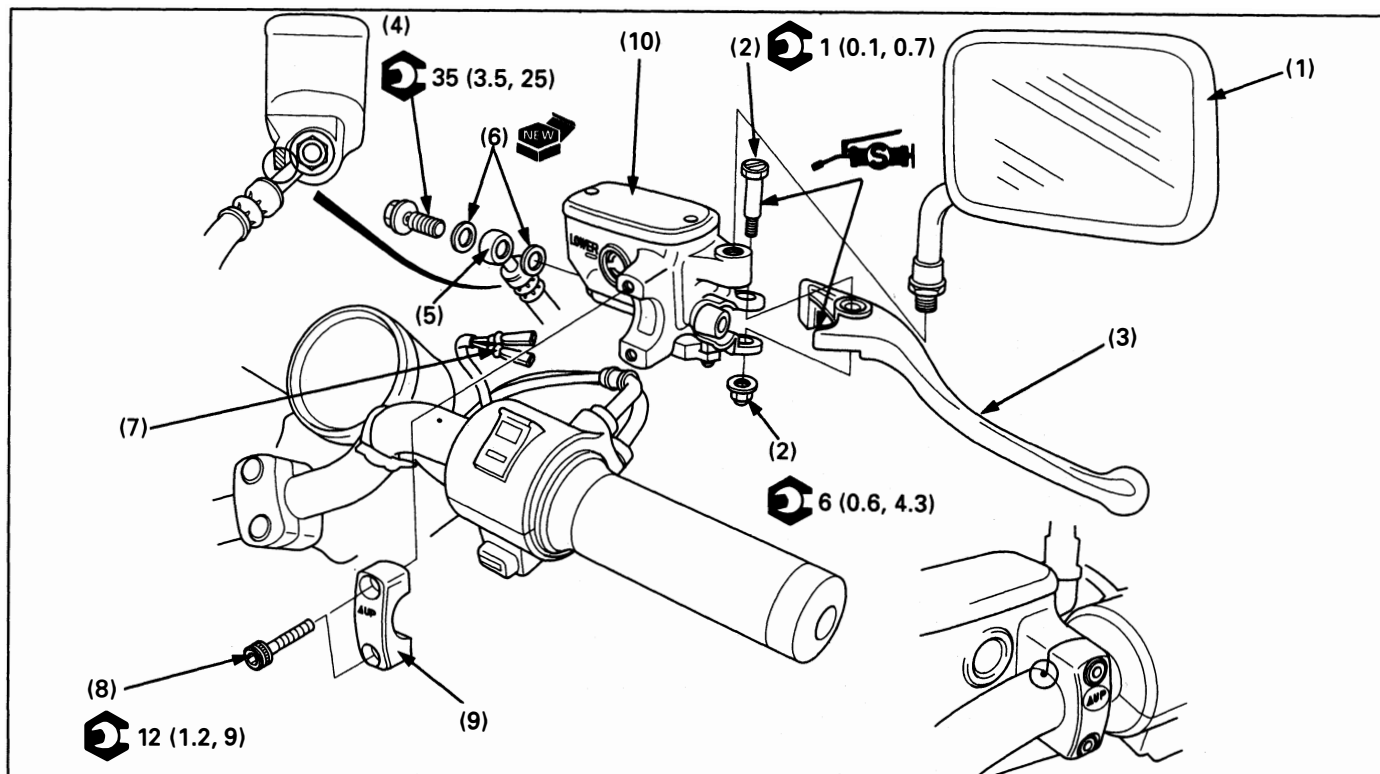

CAUTION

- Avoid spilling brake fluid on painted, plastic, or rubber parts. Place a rag over these parts whenever the system is serviced.
- When removing the hose bolt, cover the end of the brake hose to prevent contamination.
- Do not allow foreign material to enter the system.

NOTE

- Use DOT 4 brake fluid from a sealed container.

Requisite Service

- Brake system air bleeding (Section 17 of the Common Service Manual)

Procedure	Q'ty	Remarks
Removal Order		Installation is in the reverse of order of removal.
(1) Right rearview mirror	1	Loosen the mounting nut and remove the mirror.
(2) Front brake lever pivot bolt/nut	1/1	
(3) Brake lever	1	
(4) Front brake hose bolt	1	
(5) Front brake hose	1	At installation, press the hose end against the stopper while tightening the hose bolt.
(6) Sealing washer	2	
(7) Brake light switch connector	2	
(8) Master cylinder holder bolt	2	At installation, tighten the upper bolt first, then the lower bolt.
(9) Master cylinder holder	1	Install the holder with its "UP" mark facing up.
(10) Master cylinder assembly	1	At installation, align the mating surface with the punch mark on the handlebar.

Front Master Cylinder Disassembly/Assembly

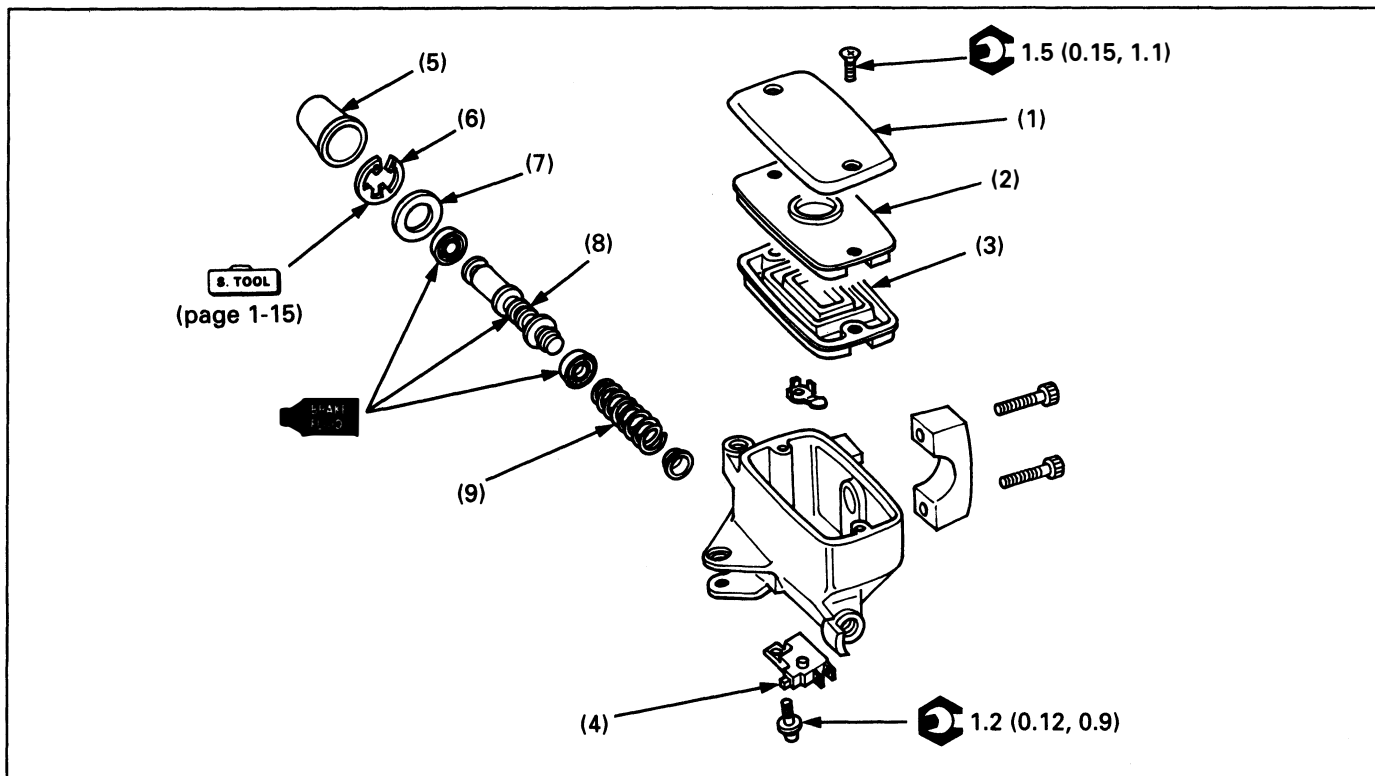

NOTE

- Replace the master piston, spring, cups, stopper plate, snap ring and boot as a set.

Requisite Service

- Front master cylinder removal/installation (page 14-5)
- Brake system air bleeding (Section 17 of the Common Service Manual)

Procedure	Q'ty	Remarks
Disassembly Order		Assembly is in the reverse order of disassembly.
(1) Reservoir cover	1	
(2) Diaphragm plate	1	
(3) Diaphragm	1	
(4) Brake light switch	1	
(5) Boot	1	
(6) Snap ring	1	CAUTION • Be certain the snap ring is fully seated in the groove.
(7) Stopper plate	1	
(8) Master piston assembly	1	
(9) Spring	1	Install the spring with the small coil end facing the piston.

Rear Brake Panel Disassembly/Assembly

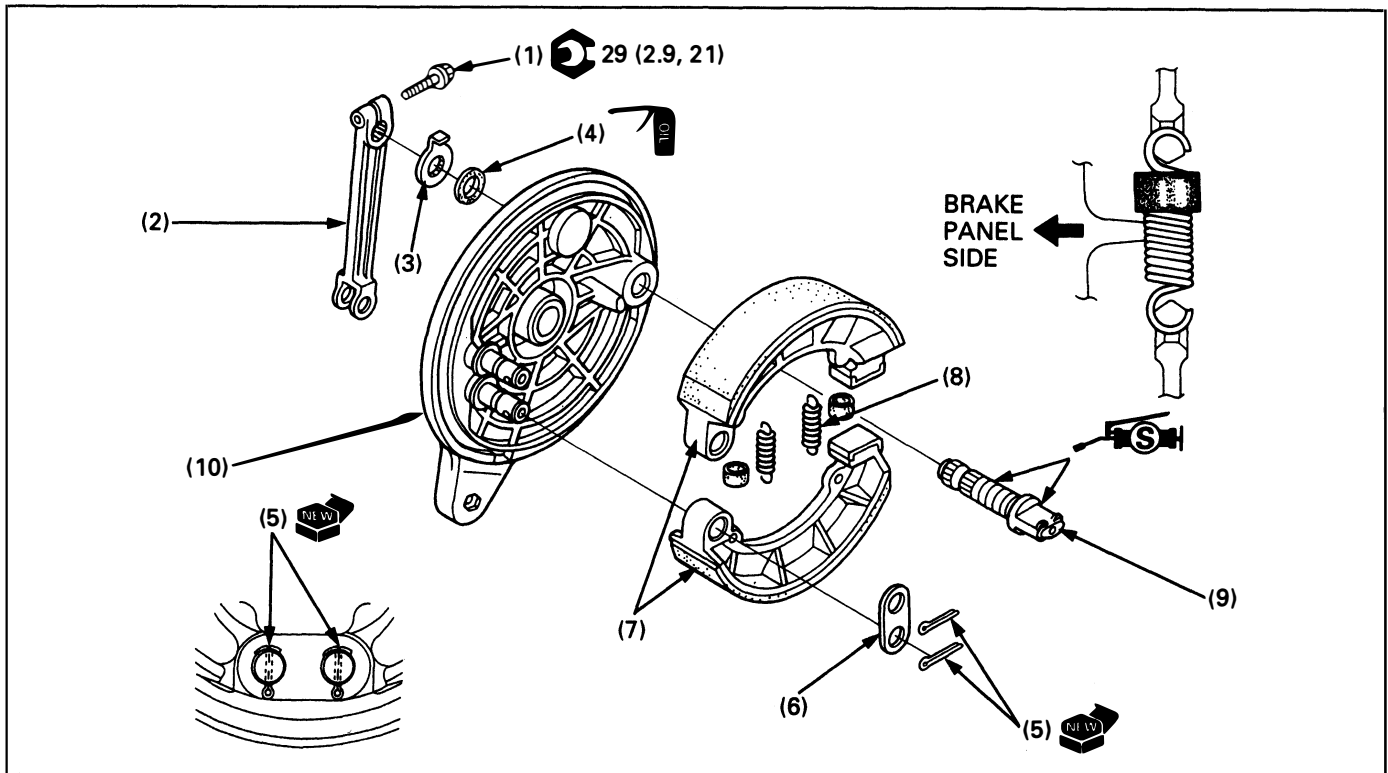

⚠ WARNING

- Inhaled asbestos fibers have been found to cause respiratory disease and cancer. Never use an air hose or dry brush to clean brake assemblies. Use an OSHA-approved vacuum cleaner or alternate method approved by OSHA designed to minimize the hazard caused by airborne asbestos fibers.
- A contaminated brake drum or shoe reduces stopping power. Discard contaminated shoes and clean a contaminated drum with a high quality brake degreasing agent.

Requisite Service

- Rear wheel removal/installation (page 13-2)

Procedure	Q'ty	Remarks
Disassembly Order		Assembly is in the reverse order of disassembly.
(1) Brake arm pinch bolt	1	
(2) Brake arm	1	At installation, align the punch marks on the brake cam and arm.
(3) Brake indicator	1	At installation, align the wide tooth with the wide slot in the brake cam.
(4) Felt seal	1	
(5) Cotter pin	2	Install with closed end facing out.
(6) Cotter pin plate	1	
(7) Brake shoe	2	
(8) Shoe spring	2	
(9) Brake cam	1	At installation, apply silicone grease to the sliding surface and cam portion.
(10) Brake panel	1	

Brake Pedal Removal/Installation

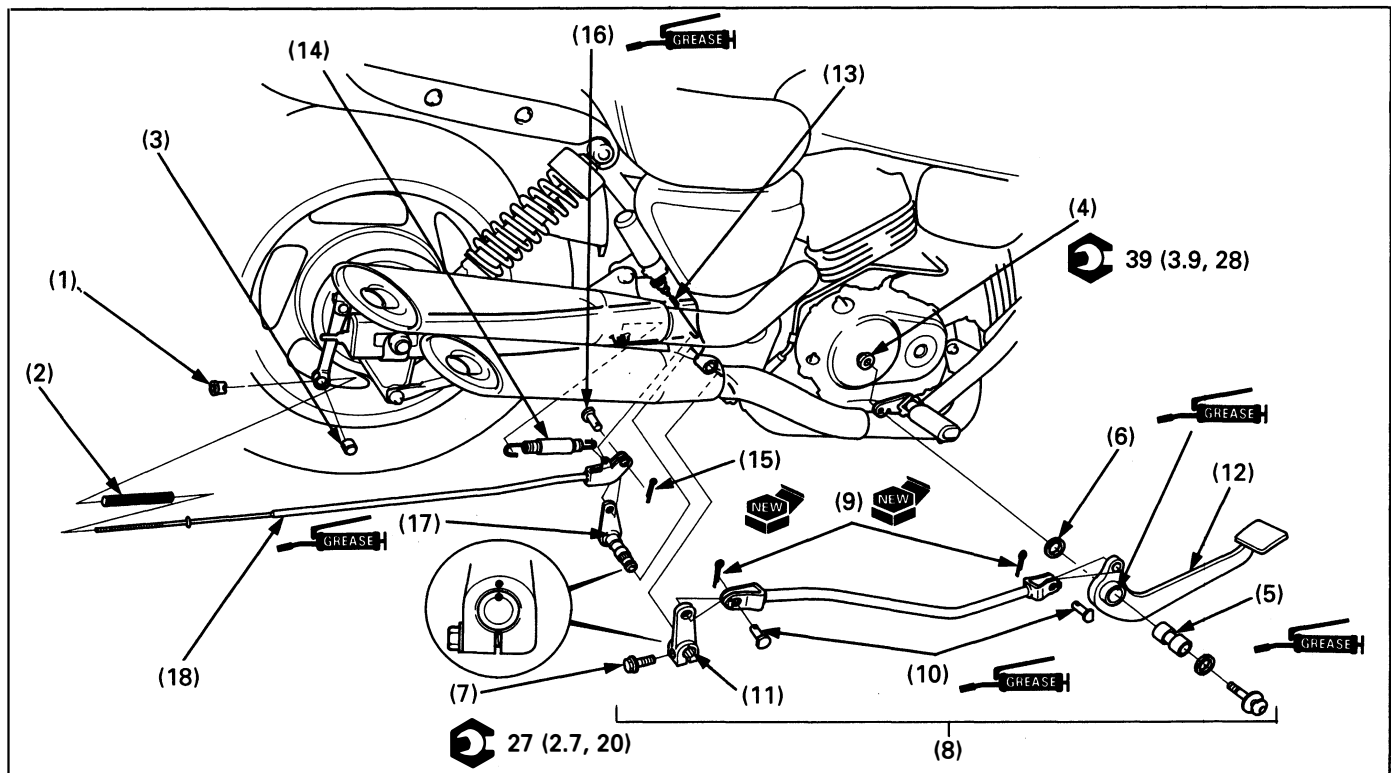

Procedure	Q'ty	Remarks
Removal Order		Installation is in the reverse order of removal.
(1) Brake rod adjusting nut	1	
(2) Brake rod spring	1	
(3) Brake rod joint piece	1	
(4) Brake pedal pivot bolt/nut	1/1	
(5) Collar	1	
(6) Dust seal	2	
(7) Brake pedal linkage joint pinch bolt	1	Align the punch marks.
(8) Brake pedal linkage assembly	1	
(9) Cotter pin	2	
(10) Joint pin	2	
(11) Brake pedal linkage joint	1	
(12) Brake pedal	1	
(13) Brake light switch spring	1	
(14) Brake pedal return spring	1	
(15) Cotter pin	1	
(16) Joint pin	1	
(17) Brake rod linkage	1	
(18) Brake rod	1	

15. Charging System/Alternator

Service Information	15-1	Charging System Inspection	15-6
System Location	15-2	Regulator/Rectifier	15-7
Troubleshooting	15-3	Alternator	15-9
Battery Removal/Installation	15-5	Alternator Removal/Installation	15-10

Service information

⚠ WARNING

- **The battery gives off explosive gases; keep sparks, flames, and cigarettes away. Provide adequate ventilation when charging or using the battery in an enclosed space.**
- **The battery contains sulfuric acid (electrolyte). Contact with skin or eyes may cause severe burns. Wear protective clothing and a face shield.**
 - **If electrolyte gets on your skin, flush with water.**
 - **If electrolyte gets in your eyes, flush with water for at least 15 minutes and call a physician immediately.**
- **Electrolyte is poisonous. If swallowed, drink large quantities of water or milk and follow with milk of magnesia or vegetable oil and call a physician.**
- **KEEP OUT OF REACH OF CHILDREN.**

- Always turn off the ignition switch before disconnecting any electrical component.

CAUTION

- **Some electrical components may be damaged if terminals or connectors are connected or disconnected while the ignition switch is ON and current is present.**

- For extended storage, remove the battery, give it a full charge, and store it in a cool, dry space. For maximum service life, charge the stored battery every two weeks.
- For battery remaining in a stored motorcycle, disconnect the negative battery cable from the battery terminal.

NOTE

- The maintenance free battery must be replaced when it reaches the end of its service life.

CAUTION

- **The battery caps should not be removed. Attempting to remove the sealing caps from the cells may damage the battery.**

- Battery can be damaged if over charged or undercharged, or if left to discharge for long periods. These same conditions contribute to shortening the "life span" of the battery. Even under normal use, battery performance deteriorates after 2-3 years.
- Battery voltage may recover after battery charging, but under heavy load, battery voltage will drop quickly and eventually die out. For this reason, the charging system is often suspected to be the problem. If one of the battery cells is shorted and battery voltage does not increase, the regulator/rectifier supplies excess voltage to the battery. Under these conditions, the electrolyte level goes down quickly.
- Before troubleshooting the charging system, check the proper use and maintenance of the battery. Check if the battery is frequently under heavy load, such as having the headlight and taillight ON for long periods of time without riding the motorcycle.
- The battery will self-discharge when the motorcycle is not in use. For this reason, charge the battery every two weeks to prevent sulfation from forming.
- Filling a new battery with electrolyte will produce some voltage, but in order to achieve its maximum performance, always charge the battery. Also, the battery life is lengthened when it is initial-charged.
- When checking the charging system, always follow the steps in the troubleshooting flow chart (page 15-3).
- For battery testing/charging, refer to Section 22 of the Common Service Manual.
- For charging system location, see page 15-2.

System Location

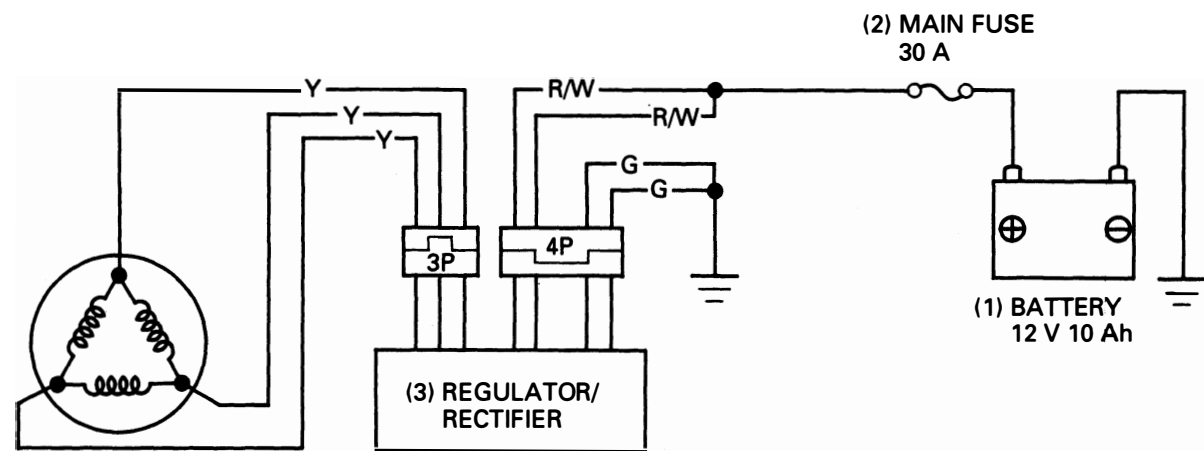
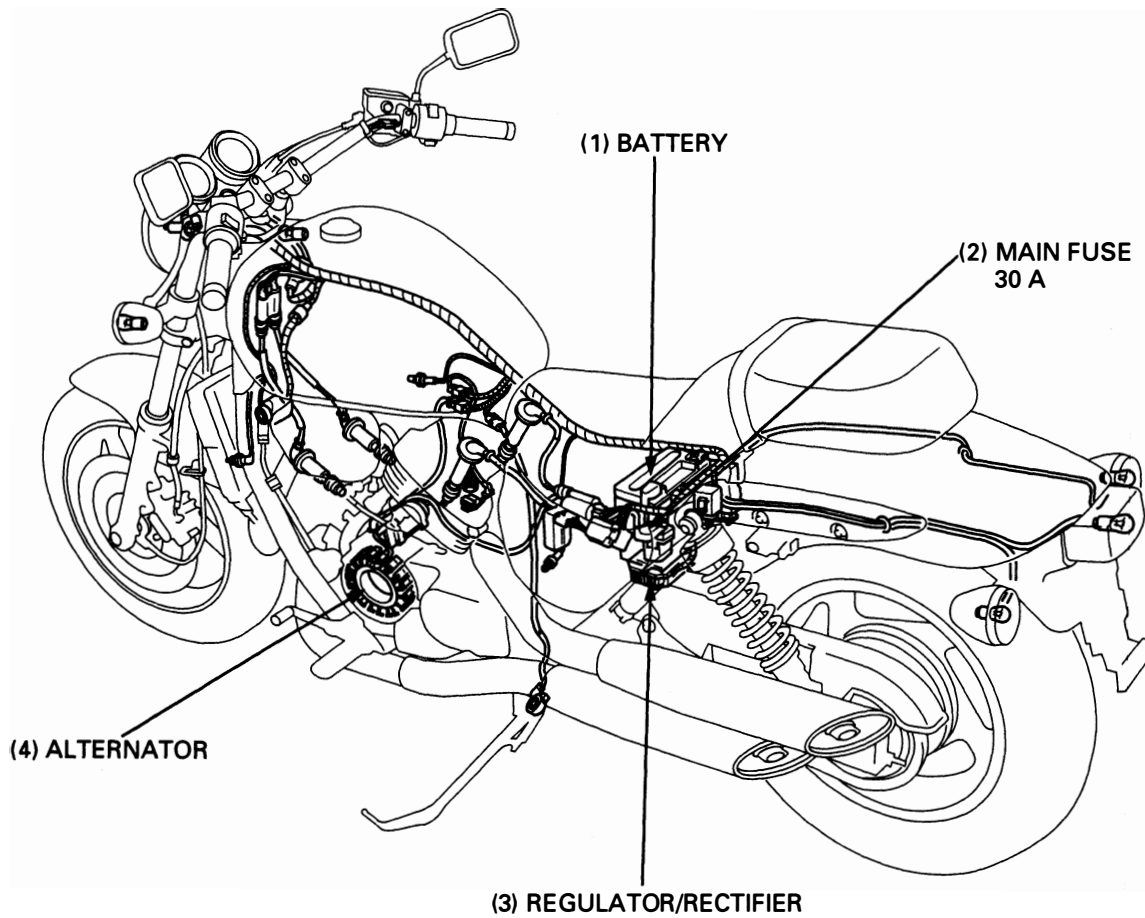

R: Red
W: White
Y: Yellow
G: Green

Troubleshooting

Battery Overcharging

- Faulty regulator/rectifier

Battery Undercharging

NOTE

- In order to obtain an accurate test reading when charging the system, the battery must be fully charged and in good condition. See Common Service Manual Section 22 for check the battery condition.

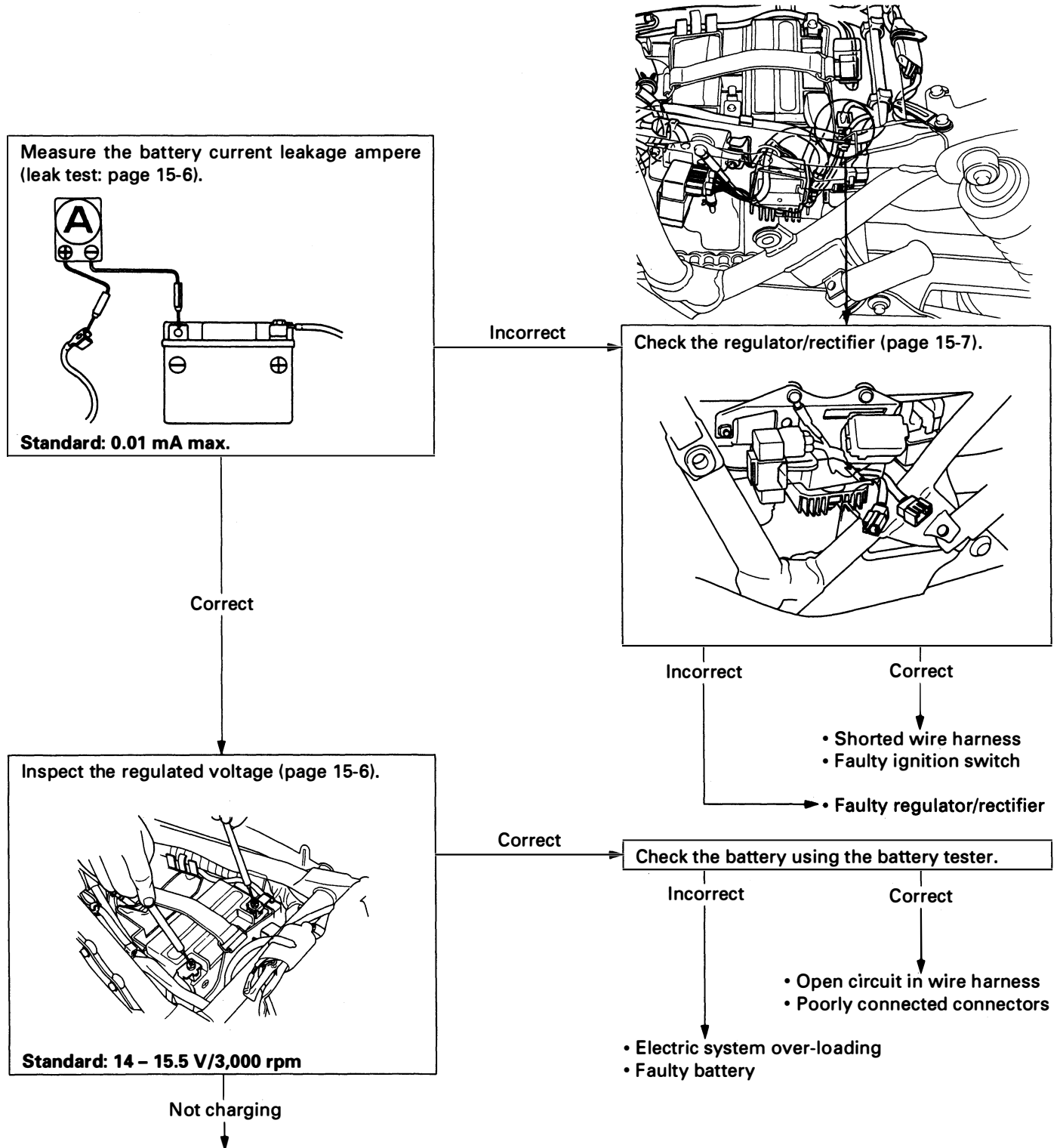

Charging System/Alternator

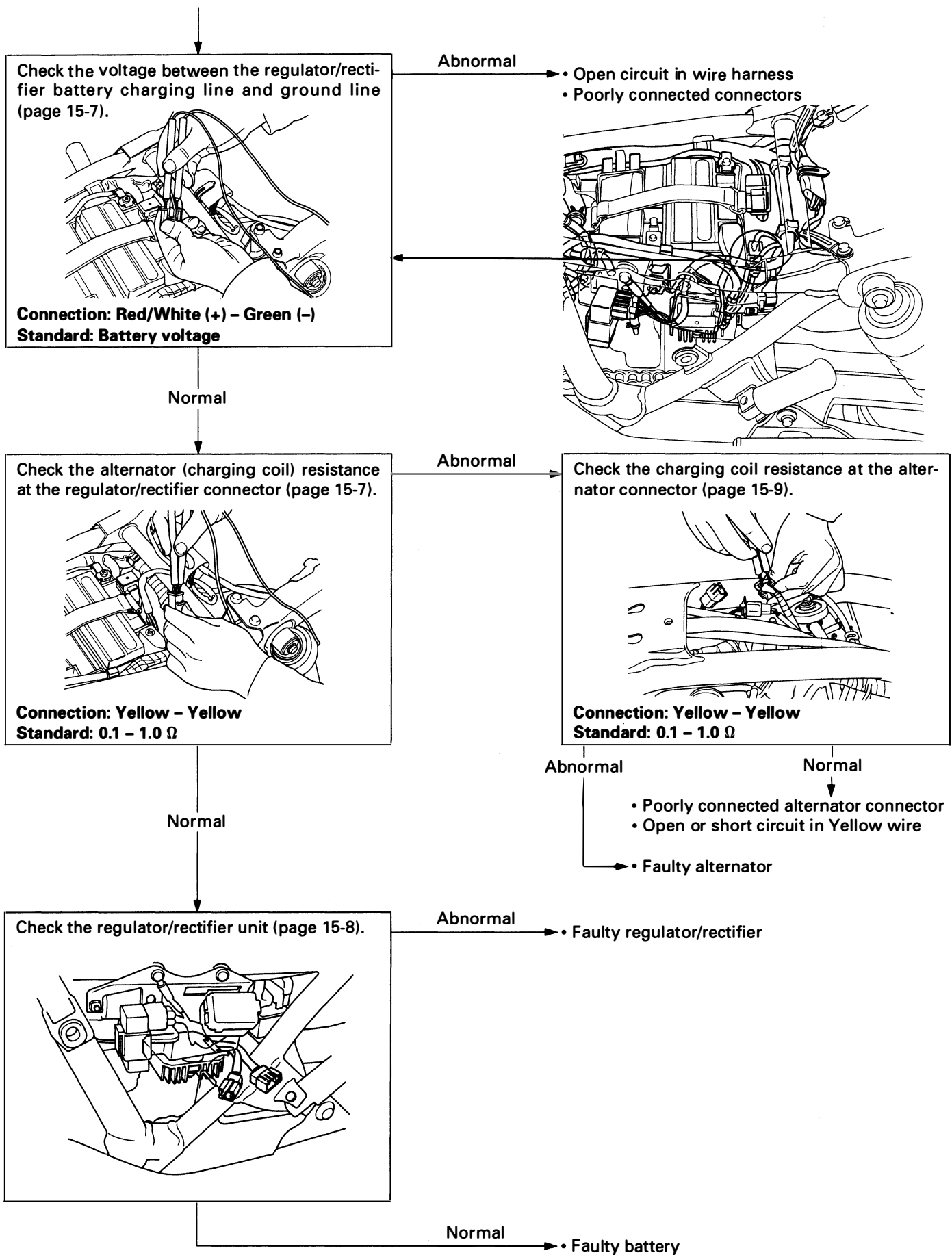

Battery Removal/Installation

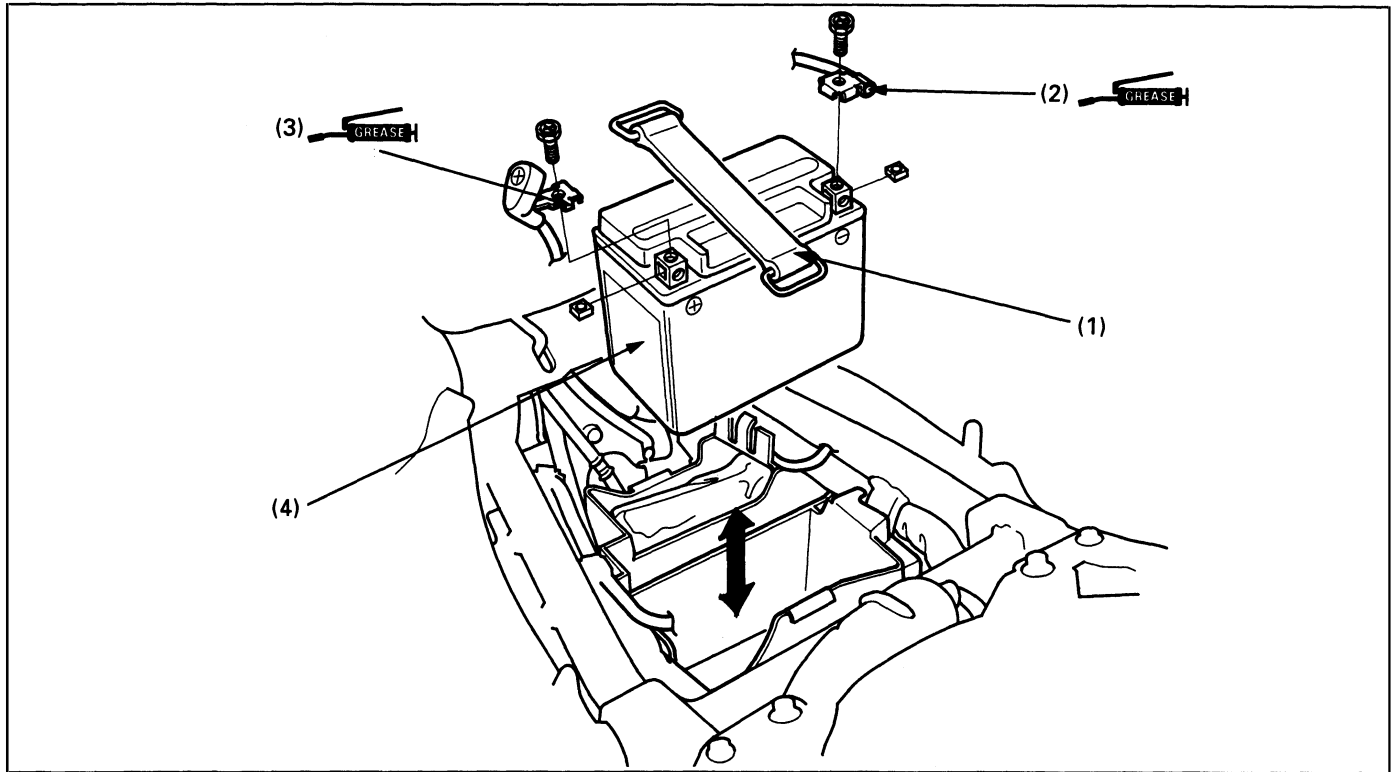

NOTE

• Always turn the ignition switch OFF before removing or installing the battery.

Requisite Service

- Seat removal/installation (page 2-2)

Procedure		Q'ty	Remarks
Removal Order			Installation is in the reverse order of removal.
(1)	Battery holder band	1	<ul style="list-style-type: none"> • After installation, apply clean grease to the cable end, battery terminals and bolts. • At installation, pull the cover over the positive terminal.
(2)	Negative terminal	1	
(3)	Positive terminal	1	
(4)	Battery	1	

Charging System Inspection

Leakage Test

Turn the ignition switch off, and disconnect the ground (-) cable from the battery.

Connect the ammeter (+) probe to the ground cable and the ammeter (-) probe to the battery (-) terminal. With the ignition switch off, check for current leakage.

NOTE

- When measuring the current using a tester, set it to a high range, and then bring the range down to an appropriate level. Current flow larger than the range selected may blow out the fuse in the tester.
- While measuring current, do not turn the ignition switch ON. A sudden surge of current may blow out the fuse in the tester.

Specified Current Leakage: 0.01 mA max.

If current leakage exceeds the specified value, a shorted circuit is likely.

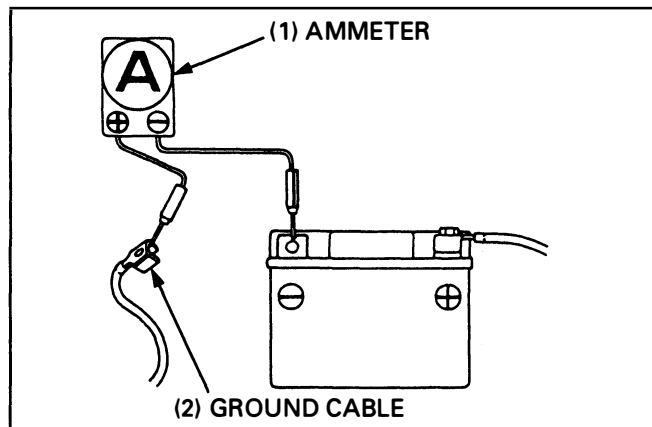

Regulated Voltage/Ampere Inspection

⚠ WARNING

- If the engine must be running to do some work, make sure the area is well-ventilated. Never run the engine in an enclosed area.
- The exhaust contains poisonous carbon monoxide gas that may cause loss of consciousness and may lead to death.

NOTE

- Before performing this test, be sure the battery is fully charged and that the voltage between its terminals is greater than 13.0 V.

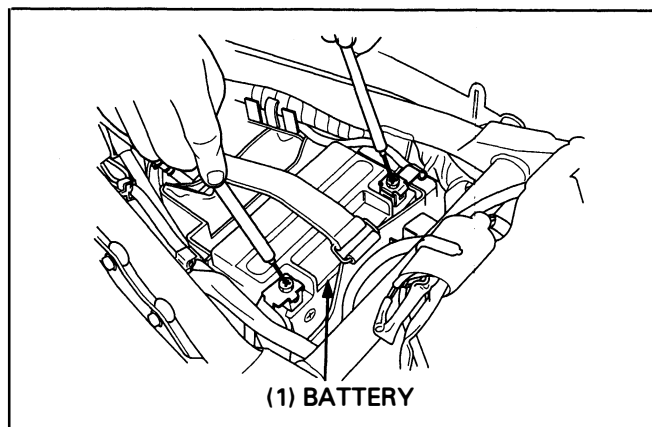

Start the engine and warm it to operating temperature, then turn the ignition switch OFF.

Connect the multimeter between the battery terminals.

8. TOOL

Digital multimeter

07411 - 0020000
Equivalent commercially
available in U.S.A.

Analogue tester

07308 - 0020001
(Not available in U.S.A.)

Disconnect the starter relay switch connector and remove the main fuse (30 A).

Reconnect the connector onto the relay switch.

Connect the ammeter between the fuse holder terminals as shown.

Start the engine and increase the engine speed gradually and check that the voltage and ampere are regulated.

CAUTION

- Be careful not to short any tester probes.
- Although the current could be measured when the ammeter is connected between the battery positive terminal and the positive cable, a sudden surge of current to the starter motor could damage the ammeter.
- Always turn the ignition switch OFF when conducting the test. Disconnecting the ammeter or wire when current is flowing may damage the ammeter.

NOTE

- Before making this test, all the lights and the other electrical equipment should be OFF.
- Use fully charged battery to make this test in order to get a correct measurement.

Regulated:

Battery terminals: 14 – 15.5 V/3,000 rpm
Charging current: 0 – 0.5 A/3,000 rpm

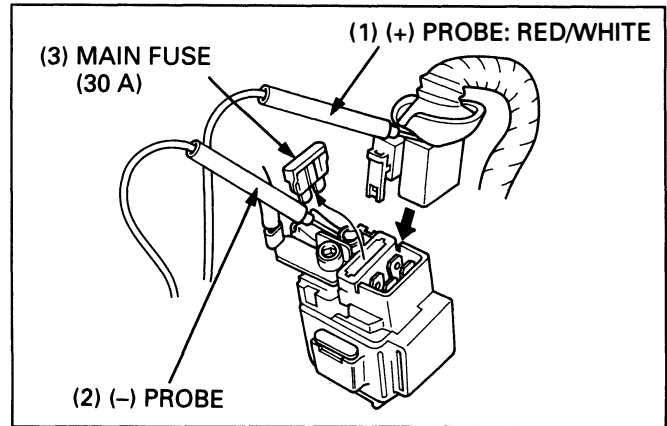

Regulator/Rectifier

System Inspection

Remove the seat (page 2-2).

Disconnect the regulator/rectifier connectors.
Check the connectors for loose or corroded terminal.

Measure the following between connector terminal of the wire harness side.

Item	Terminals	Specification
Battery charging line	Red/White (+) and Green (-)	Battery voltage should register.
Ground line	Green and ground	Continuity exist.
Charging coil line	Yellow and Yellow	0.1 – 1.0 Ω (20°C/68°F)

If the charging coil line reading is out of specification, check the alternator (page 15-9).

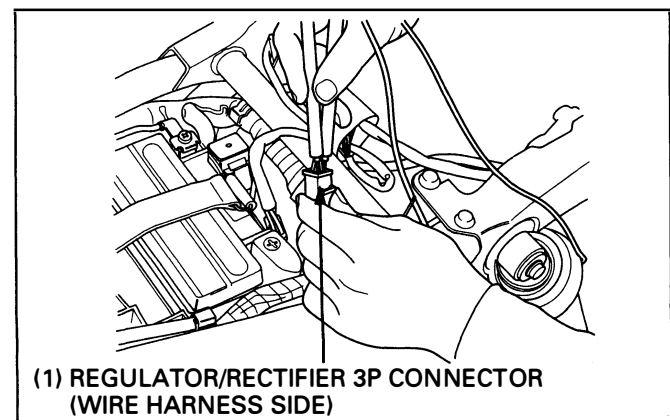
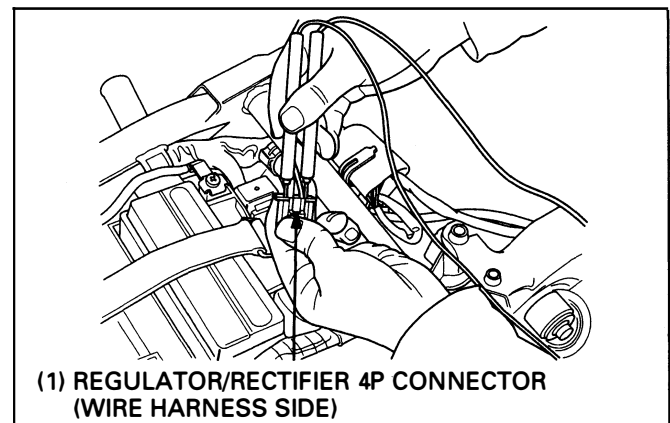

Charging System/Alternator

Unit Inspection

Provided the circuit on the wire harness side is normal and there are no loose connections at the connectors, inspect the regulator/rectifier unit by measuring the resistance between the terminals.

NOTE

- You'll get false readings if the probes touch you fingers.
- Use the specified multimeters. Using other equipment may not allow you to obtain the correct results. This is due to the characteristic of semiconductors, which have different values depending on the applied voltage.
- **Specific Multimeter:**
 - 07411 – 002000 (KOWA Digital type)
 - 07308 – 002001 (SANWA Analogue type)
- Select the following range:
 - SANWA: x kΩ
 - KOWA: x 100
- Using an old battery stored in the multimeter can cause inaccurate readings. Check the battery if the multimeter resistance is incorrect.
- When using the KOWA multimeter, remember that all readings should be multiplied by 100.

Replace the regulator/rectifier unit if the resistance value between the terminals is abnormal.

Unit: Ω

+ Probe \ - Probe	Red/White	Yellow	Yellow	Yellow	Green
Red/White		∞	∞	∞	∞
Yellow	500 ~ 10k		∞	∞	∞
Yellow	500 ~ 10k	∞		∞	∞
Yellow	500 ~ 10k	∞	∞		∞
Green	700 ~ 15k	500 ~ 10k	500 ~ 10k	500 ~ 10k	

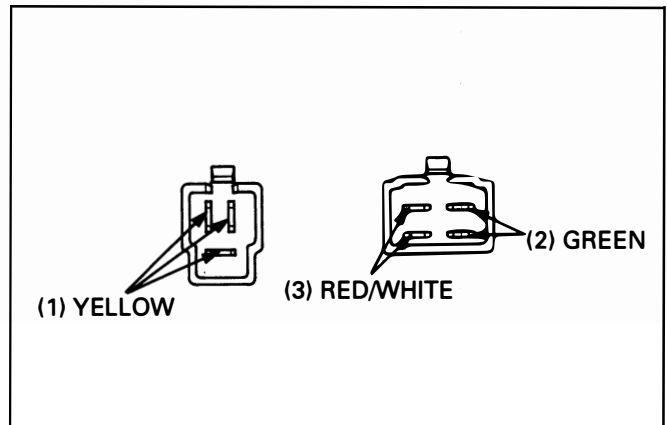
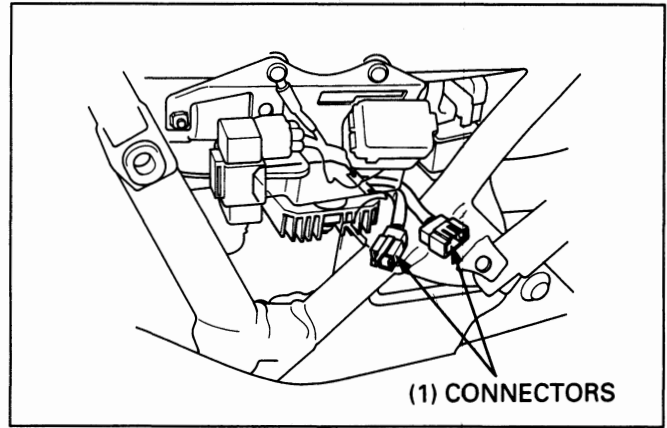

Removal/Installation

Disconnect the regulator/rectifier connectors. Remove the mounting nuts and regulator/rectifier unit.

Installation is in the reverse order of removal.

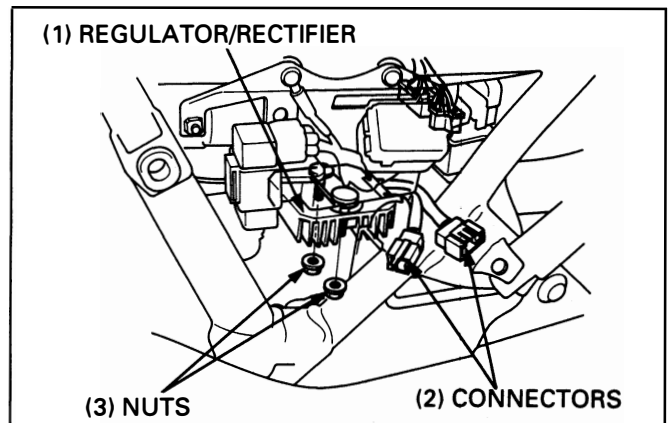

Alternator

NOTE

- It is not necessary to remove the stator to make this test.

Remove the fuel tank (page 2-2).
Disconnect the alternator 3P connector.

Measure the resistance between the Yellow wire terminals and check for no continuity between each terminal and body ground.

Standard: 0.1 – 1.0 Ω (20°C/68°F)

Replace the stator if the resistance is out of specification or if there is continuity between Yellow wire terminal and ground.

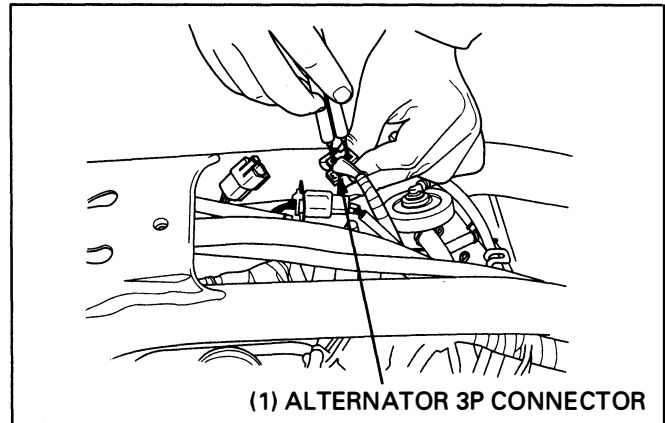

Alternator Removal/Installation

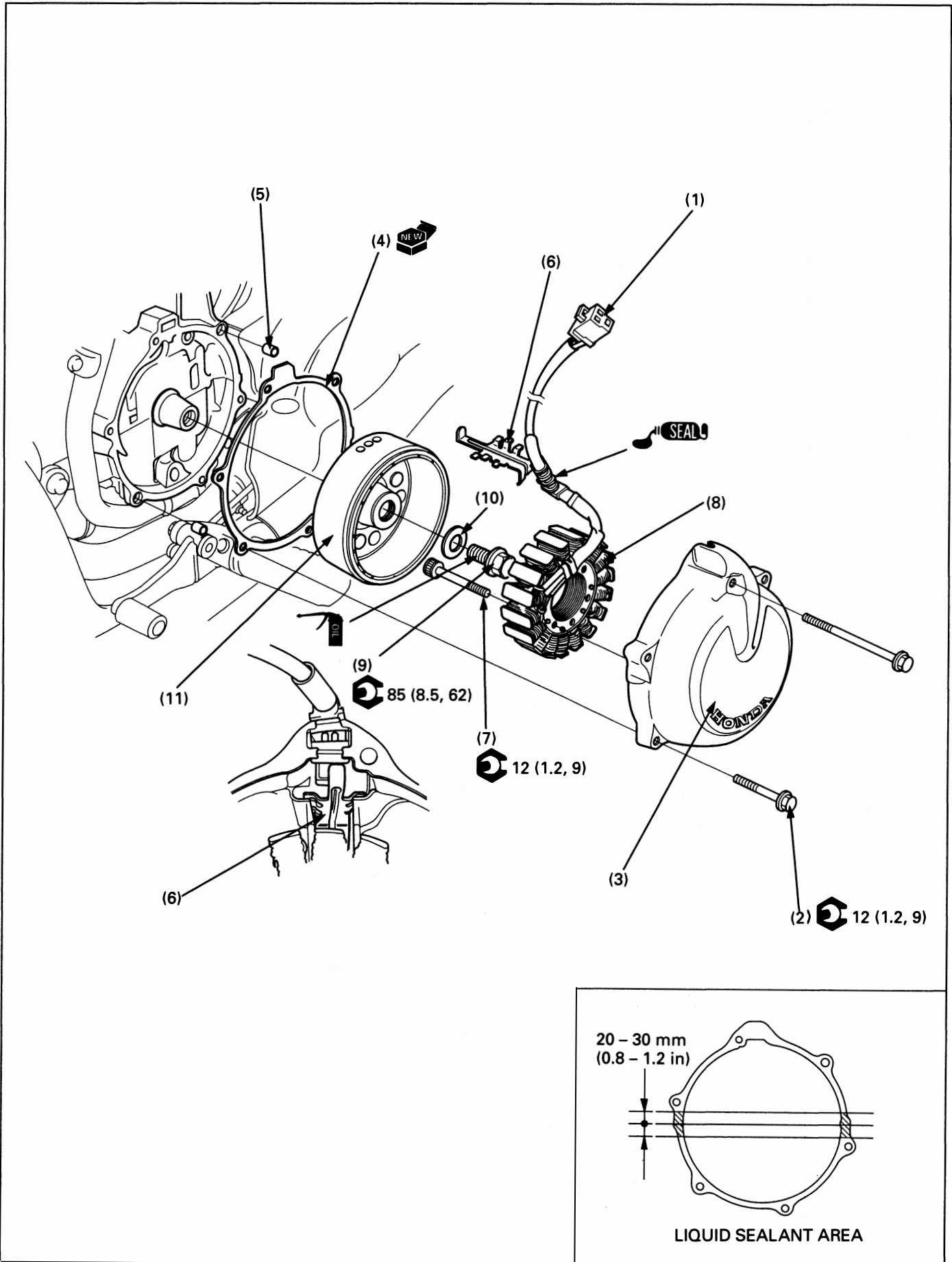

NOTE

- The engine oil will run out when the left crankcase cover is removed. Set a clean oil pan under the engine and add the recommended oil to the specified level after the installation.
- The left crankcase cover (stator) is magnetically attached to the flywheel, be careful to the removal/installation.
- Apply a light but thorough coating of liquid sealant to the crankcase as shown.

Requisite Service

- Fuel tank removal/installation (page 2-2)

Procedure		Q'ty	Remarks
	Removal Order		Installation is in the reverse order of removal.
(1)	Alternator connector	1	
(2)	Left crankcase cover bolt	6	
(3)	Left crankcase cover	1	
(4)	Gasket	1	
(5)	Dowel pin	2	
(6)	Stator wire holder	1	
(7)	Stator mounting bolt	4	
(8)	Stator assembly	1	At installation, apply sealant to the grommet and install the grommet securely into the groove in the left crankcase cover.
	Flywheel Removal Order		Installation is in the reverse order of removal.
(9)	Flywheel bolt	1	Apply clean engine oil to the bolt threads.
(10)	Washer	1	
(11)	Flywheel	1	Before installation, wipe any oil off the mating surface of the crankshaft and flywheel.

MEMO

16. Ignition System

Service Information	16-1	Ignition Coil Removal/Installation	16-9
System Location	16-2	Ignition Control Module (ICM) Removal/Installation	16-10
Troubleshooting	16-3	Ignition Pulse Generator Removal/Installation	16-11
Ignition System Inspection	16-8	Ignition Timing	16-12
Ignition Coil Inspection	16-8		
Ignition Pulse Generator Inspection	16-9		

Service Information

⚠ WARNING

- If the engine must be running to do some work, make sure the area is well-ventilated. Never run the engine in an enclosed area.
- The exhaust contains poisonous carbon monoxide gas that may cause loss of consciousness and lead to death.

CAUTION

- Some electrical components may be damaged if terminals or connectors are connected or disconnected while the ignition switch is ON and current is present.

- When checking the ignition system, always follow the steps in the troubleshooting flow chart (page 16-3).
- The Ignition control module (ICM) may be damaged if dropped. Also, if the connector is disconnected when current is present, the excessive voltage may damage the unit. Always turn off the ignition switch before servicing.
- Ignition timing cannot be adjusted since the Ignition control module (ICM) is non-adjustable. If ignition timing is incorrect, check the system components and replace any faulty parts.
- A faulty ignition system is often related to poorly connected or corroded connectors. Check those connections before proceeding.
- Use spark plugs of the correct heat range. Using spark plugs with an incorrect heat range can damage the engine. Refer to Section 2 of the Common Service Manual.
- For neutral switch inspection, refer to Section 25 of the Common Service Manual. For switch location, see page 16-2 of this manual (System Location).
- For side stand switch, engine stop switch and ignition switch inspection, check for continuity chart of the Wiring Diagram, page 19-1. Disconnect the ignition and engine stop switch connectors in the front side cover (page 2-3), side stand switch connector under the fuel tank and check it.

System Location

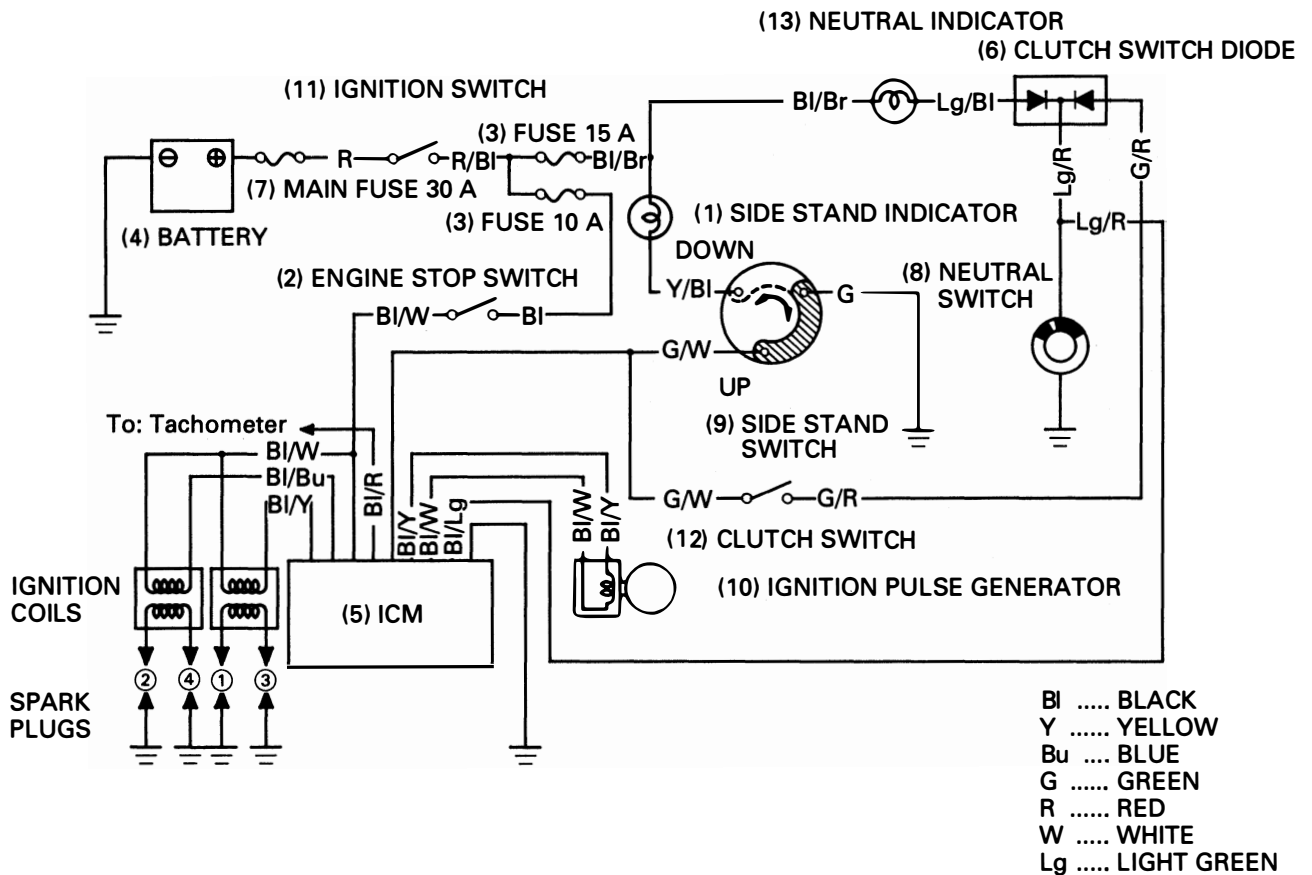
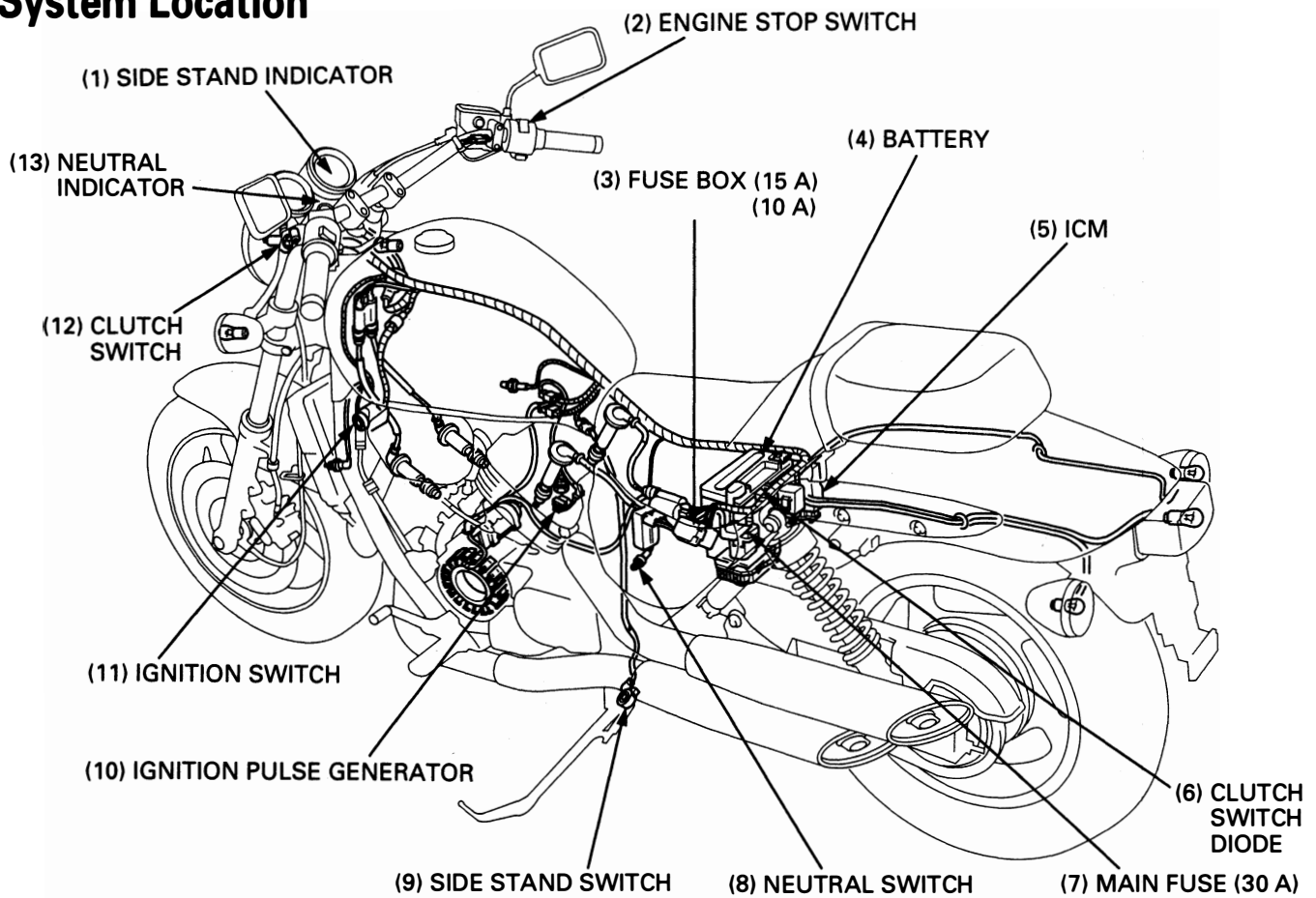

Troubleshooting

- Inspect the following before diagnosing the system.
 - Loose spark plug caps or spark plug wire connections.
 - Water in the spark plug cap.
 - Loose or poor contact of ignition system connectors.

No Spark At All Plugs (Faulty Input System)

- If there is no spark to the plugs, the problem could be the input to the ignition system (ignition pulse generator, power input circuit of the ignition control module (ICM), neutral switch, or side stand switch because it controls the ignition control module (ICM)).

Check if the battery voltage is measured between power source input line at the ignition control module (ICM) connector with the ignition switch ON and the engine stop switch at RUN (page 16-8).

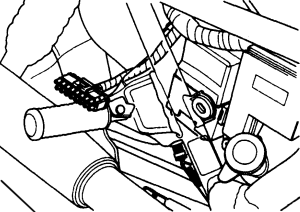

Connection: Black/White (+) – Green (-)
Standard: Battery voltage

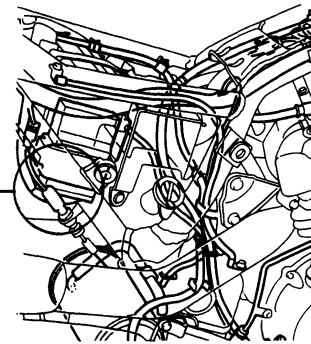

No voltage

- Faulty ignition switch or engine stop switch
- Open circuit in wire harness
- Loose or poor connector contact

Battery voltage measured

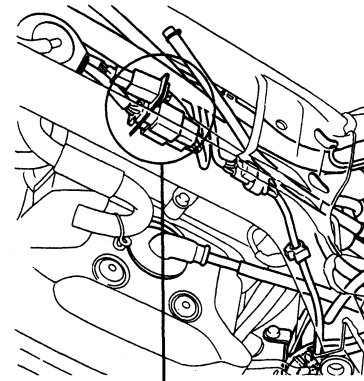

Measure the ignition pulse generator resistance at the ignition control module (ICM) connector (page 16-8).

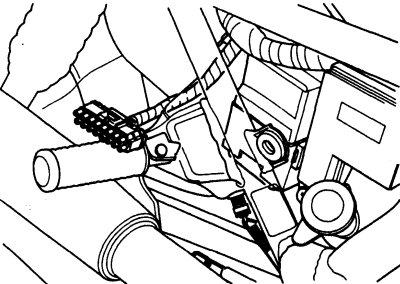

Connection: Black/Yellow – Black/White
Standard: 450 – 550 Ω

Abnormal

Check the ignition pulse generator (page 16-9).

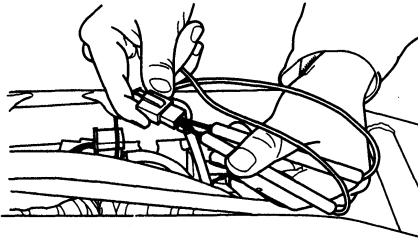

Connection: Black/Yellow – Black/White
Standard: 450 – 550 Ω

Normal

Normal

Abnormal

- Faulty ignition pulse generator
- Open circuit in Black/White wire
- Open circuit in Black/Yellow wire
- Loosen or poor ignition pulse generator connector contacts

Ignition System

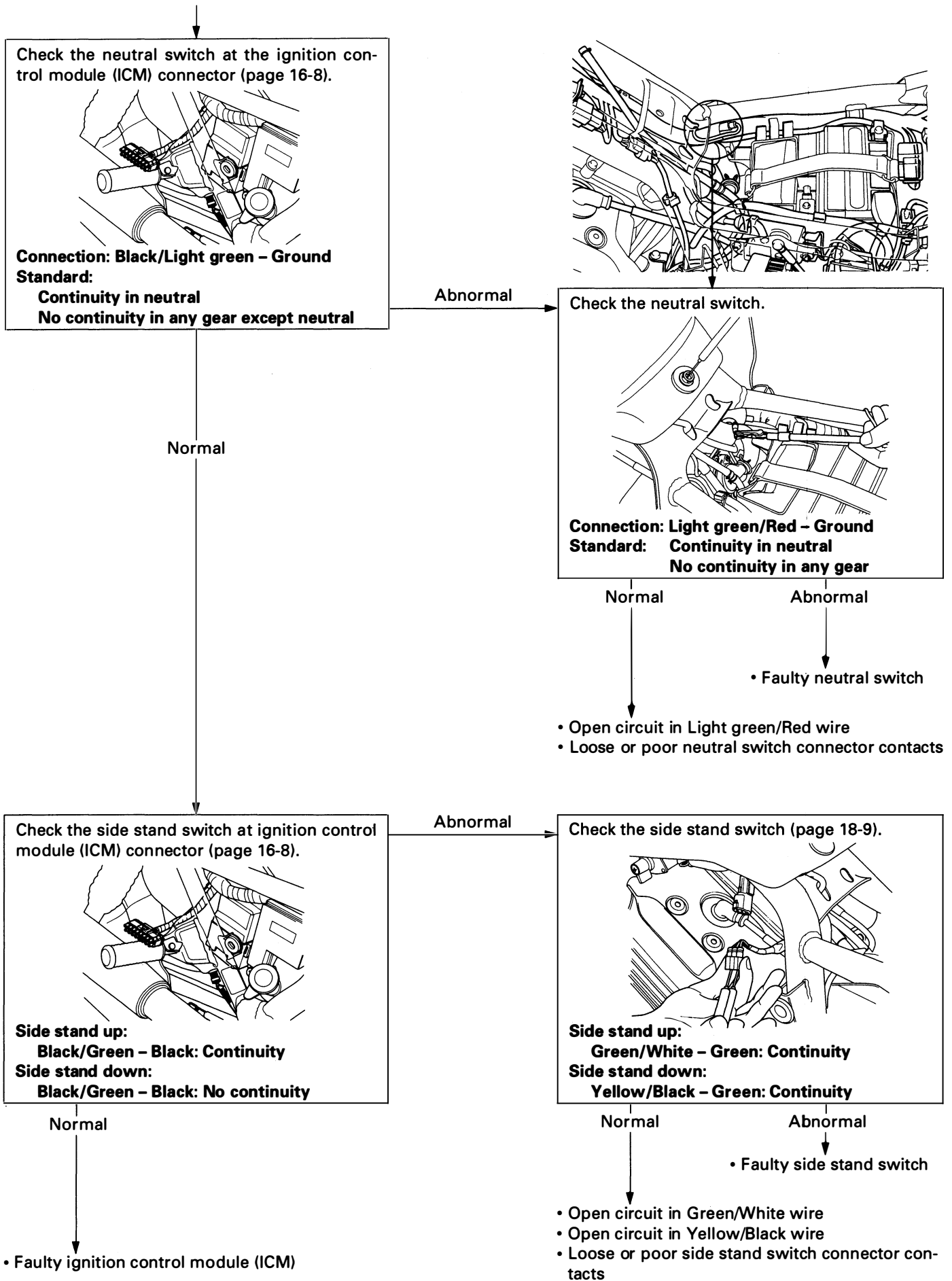

No Spark At Either Ignition Group

- If there is no spark at either group, the problem is probably in the primary coil side of the ignition system (ignition coil, or unit and ignition coil circuit).

Switch the ignition coil primary terminal connection between the faulty pair and good pair. Try spark test again.

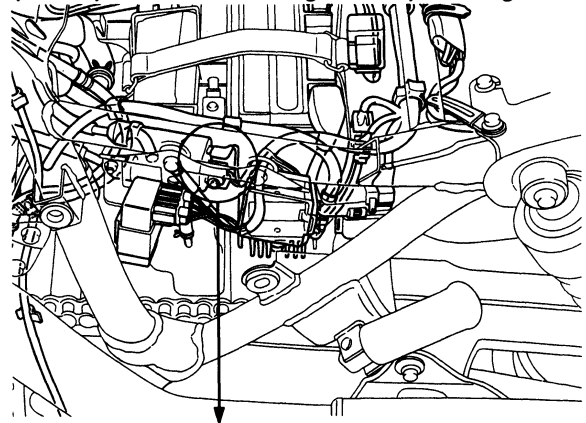
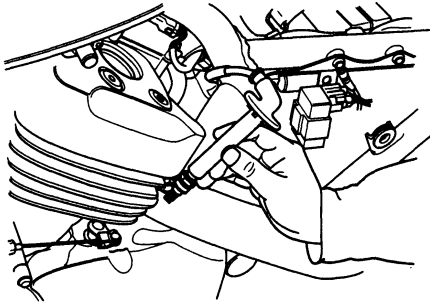

"No spark" condition remains with the faulty pair

Remove the faulty ignition coils and check the ignition coil resistance (page 16-8).

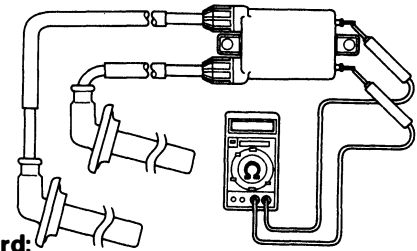

Standard:

Primary: 2 - 4 Ω

Between the plug caps: 23 - 27 k Ω

Between the spark plug wire: 13 - 17 k Ω

Abnormal

- Faulty ignition coil
- Faulty spark plug wire
- Faulty spark plugs

"No spark" condition shift to other pair

Measure resistance of the ignition primary coil at ignition control module (ICM) connector.

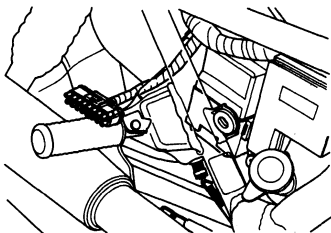

Connection:

No. 1-3: Black/White - Black/Yellow

No. 2-4: Black/White - Black/Blue

Standard: 2 - 4 Ω

Normal

- Faulty ignition control module (ICM)

Abnormal

- Poor or loose ignition coil connector contacts
- Open circuit in Black/White wire
- Open circuit in Black/Yellow wire
- Open circuit in Black/Blue wire

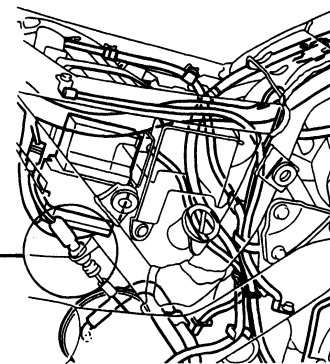

Ignition System

No Spark At One Plug (Trouble In Secondary Coil Side)

- Faulty spark plug is most likely.

Replace (suspected bad spark plug) with known good spark plug and conduct spark test.

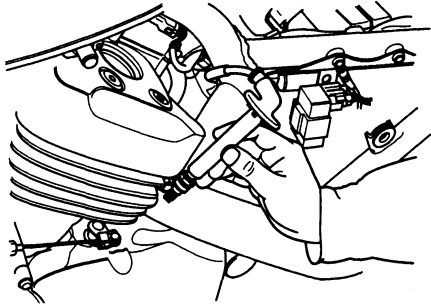

Spark

- Original spark plug faulty

No spark

Put the spark plug cap on and measure resistance of ignition secondary coil (page 16-8).

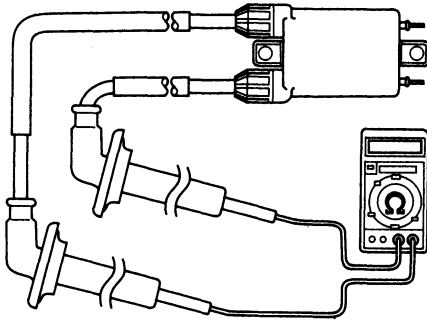

Standard: 23 - 27 k Ω

Normal

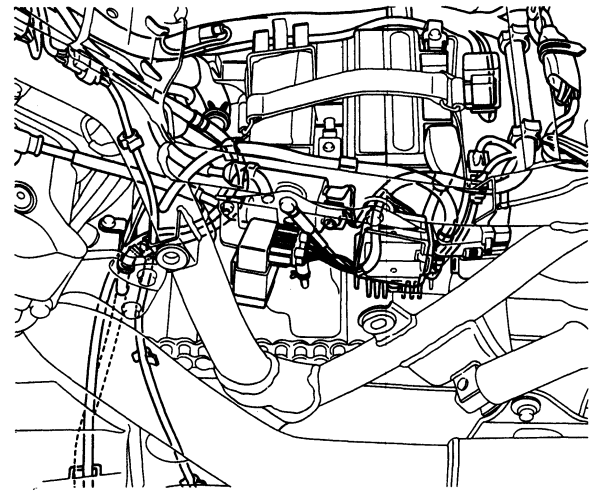

Conduct spark test on good ignition coil.

Abnormal

Remove the spark plug cap, and measure resistance of the ignition coil (page 16-9).

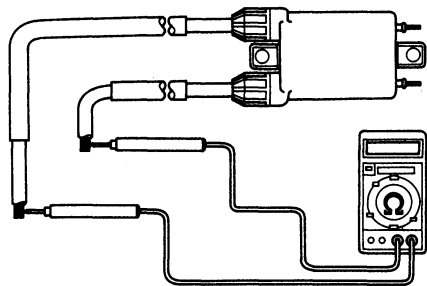

Standard: 13 - 17 k Ω

Abnormal

- Faulty ignition coil

Spark

Normal

- Poor contact of spark plug cap
- Faulty spark plug cap
- Faulty spark plugs

Engine Starts, But Side Stand Switch Does Not Function

NOTE

The side stand switch should function as follows:

- When the transmission is shifted into a gear from neutral with the side stand down, the ignition shuts off and the engine stops.
- When in neutral, the neutral switch line (a) of the ignition control module (ICM) is connected to ground via the side stand switch.

When the side stand is up, the side stand switch line (b) of the ignition control module (ICM) passes to ground via the side stand switch. The ignition control module (ICM) monitors lines (a) and (b), and provides spark only when one or both of those lines is connected to ground via the neutral switch or the side stand switch.

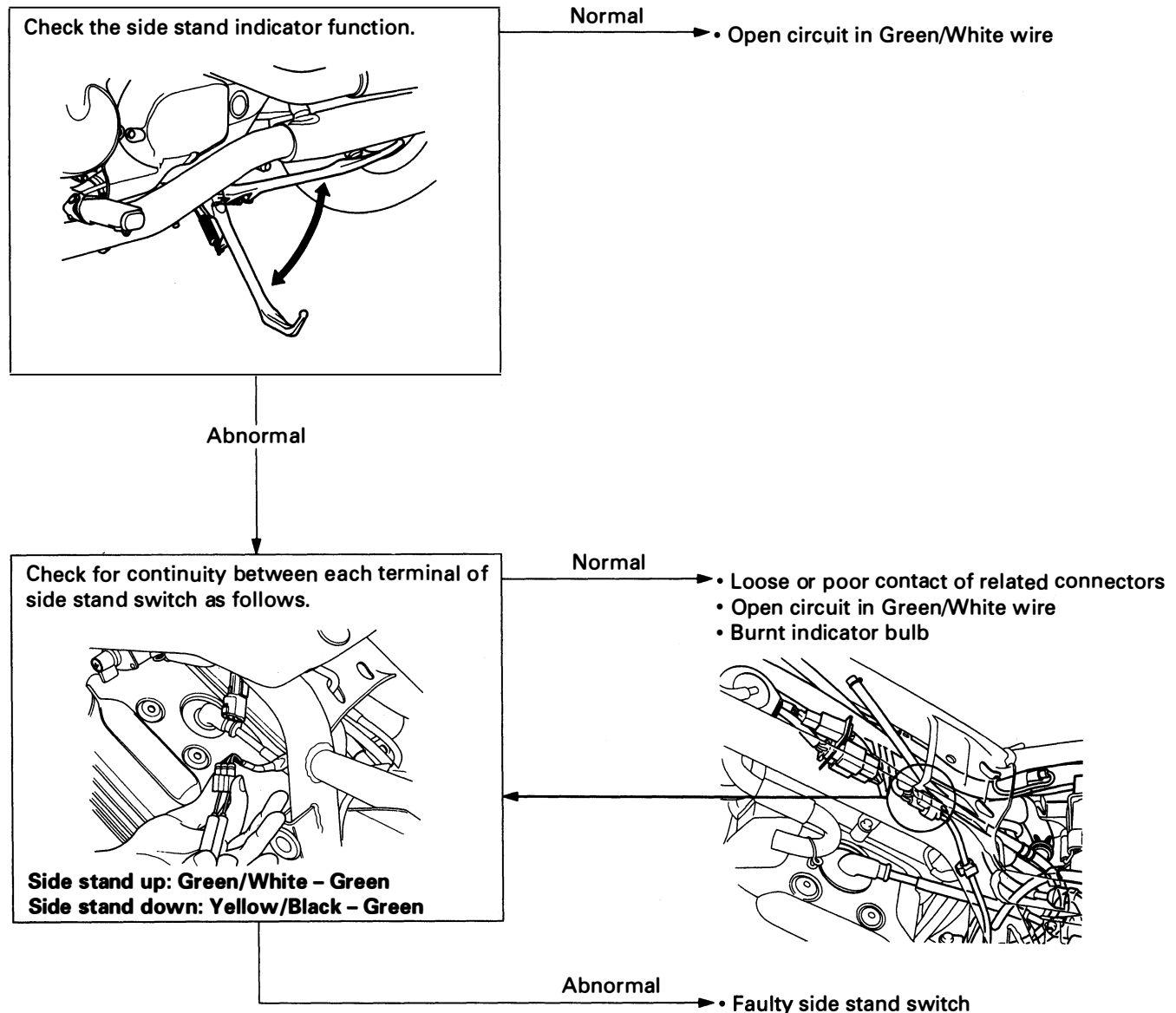

Ignition System Inspection

NOTE

- Check the system components and wires step-by-step according to the troubleshooting chart on pages.

Remove the seat (page 2-2).
 Disconnect the connector from the ignition control module (ICM) and conduct these tests at the connector.

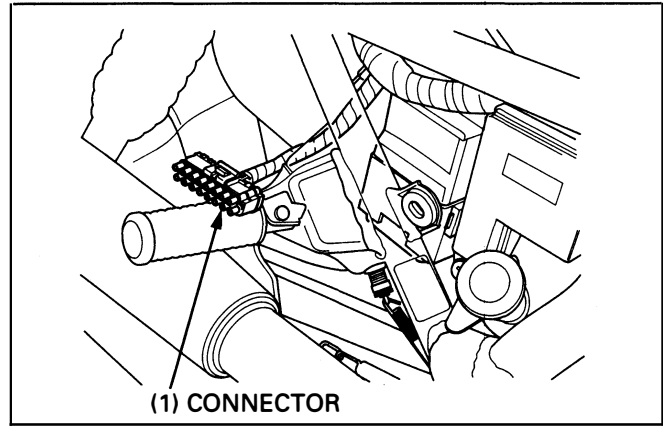

Item	Terminals	Standard
Power source input line	Black/White (+) – Green (-)	Battery voltage should register with the ignition switch ON and the engine stop switch at RUN.
Ignition primary coil	No. 1-3: Black/White – Black/Yellow No. 2-4: Black/White – Black/Blue	2–4 Ω
Ignition pulse generator coil	Black/Yellow – Black/White	450 – 550 Ω
Neutral switch line	Black/Light green – Body ground	Continuity in neutral No continuity in any gear except neutral
Side stand switch line	Black/Green – Black	Continuity with the side stand up No continuity with the side stand down
Ground line	Green – Body ground	Continuity

Ignition Coil Inspection

Measure the primary coil resistance between the terminals.

Standard: 2 – 4 Ω

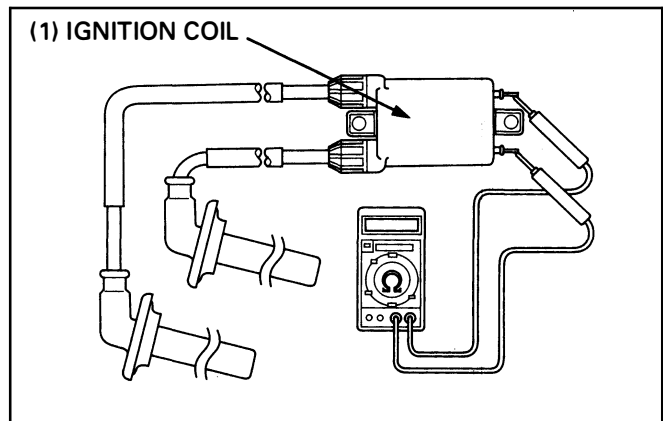

Measure the resistance between the spark plug caps.

Standard: 23 – 27 kΩ

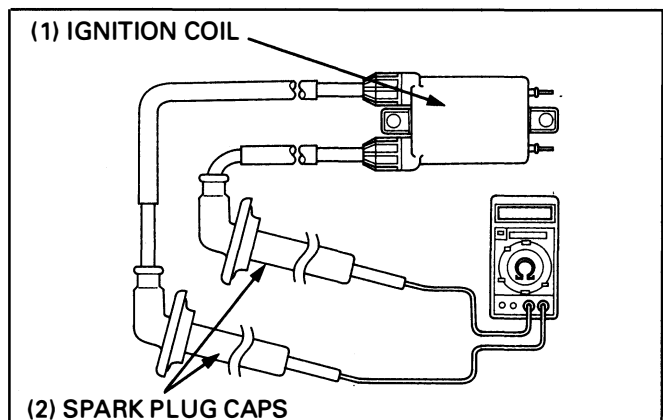

If the measured value out of the specification, remove the spark plug caps from the spark plug wires and measure the resistance between the spark plug wires.

Standard: 13 – 17 k Ω

Ignition Pulse Generator Inspection

NOTE

- It is not necessary to remove the pulse generator from the engine.

Remove the fuel tank (page 2-2).

Disconnect the ignition pulse generator 3P (White) connector.

Measure the resistance between the Black/Yellow and Black/White terminals.

Standard: 450 – 550 Ω

Refer to page 16-11 for ignition pulse generator replacement.

Ignition Coil Removal/Installation

Front

Remove the air cleaner housing (page 5- 3).

Remove the spark plug caps from spark plugs.
Disconnect the ignition coil primary wires from the coil.
Remove the ignition coil mounting bolts and front ignition coil.

Installation is in the reverse order of removal.

Rear

Remove the seat and left side cover (page 2-2, 3).

Remove the fuse box stay bolts and frame ground cable.

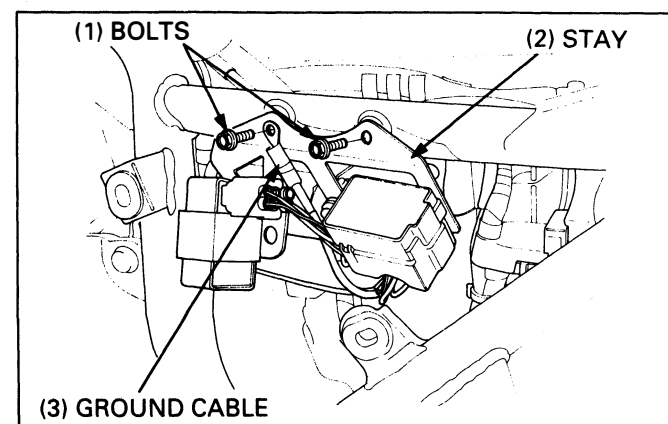
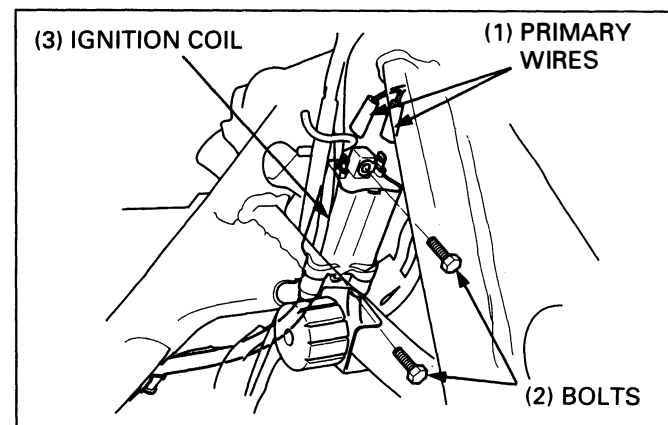
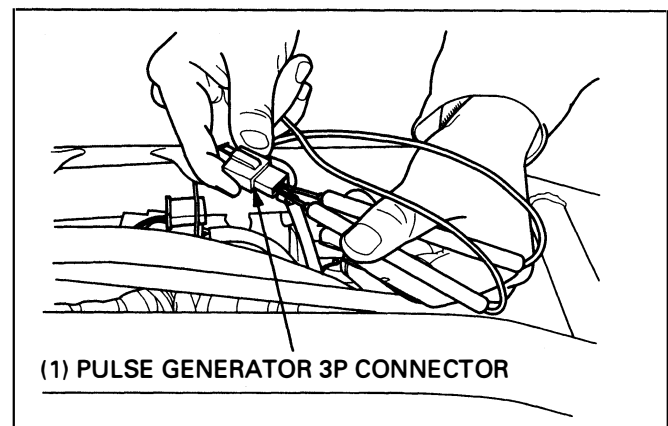
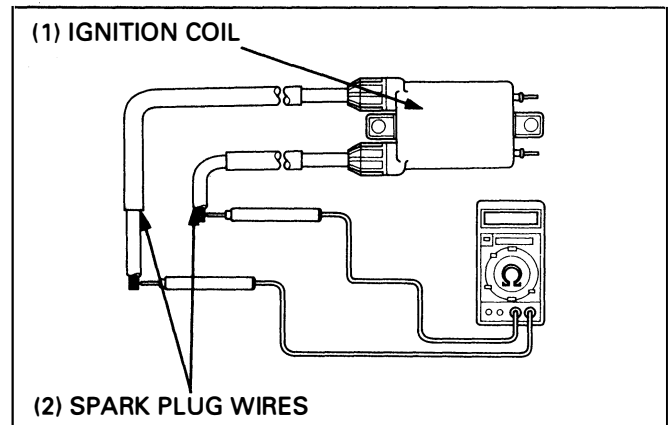

Ignition System

Remove the spark plug caps from spark plugs.
Disconnect the ignition coil primary wires from the coil.
Remove the ignition coil mounting bolts and front ignition coils.

Installation is in the reverse order of removal.

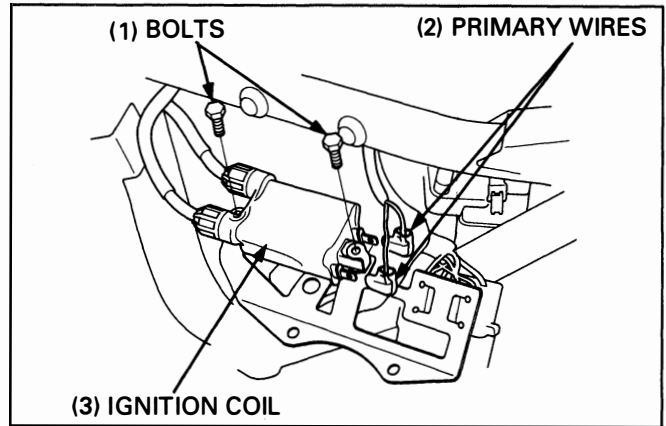

Ignition Control Module (ICM) Removal/Installation

Remove the battery case mounting bolts.

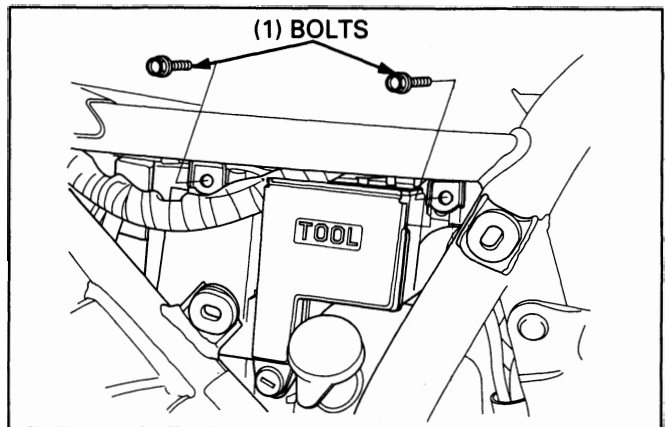

Move the battery case left ward and disconnect the ignition control module (ICM) connector.
Remove the ignition control module (ICM).

Installation is in the reverse order of removal.

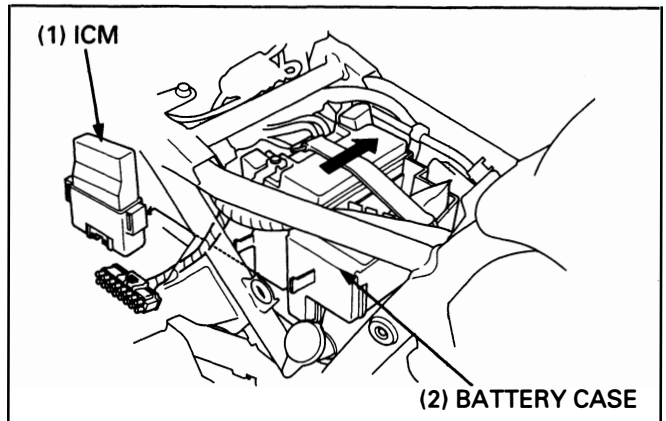

Ignition Pulse Generator Removal/Installation

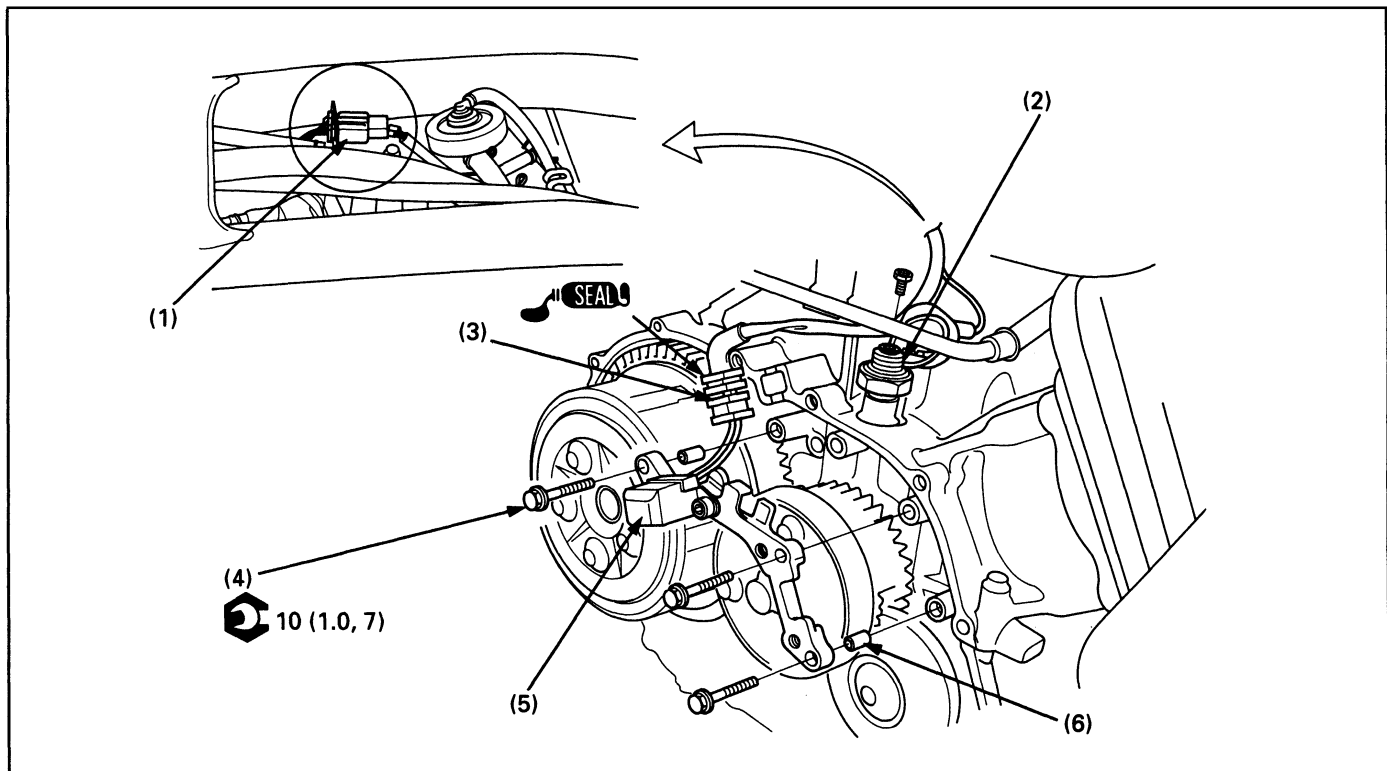

Requisite Service

- Right crankcase cover removal/installation (page 9-2)
- Fuel tank removal/installation (page 2-2)

Procedure		Q'ty	Remarks
Removal Order			Installation is in the reverse order of removal.
(1)	Ignition pulse generator connector	1	
(2)	Oil pressure switch terminal	1	
(3)	Ignition pulse generator wire grommet	1	At installation, apply sealant to the wire grommet, and install the into the rotor cover groove securely.
(4)	Ignition pulse generator mounting bolt	3	
(5)	Ignition pulse generator assembly	1	Route the ignition pulse generator wire as shown.
(6)	Dowel pin	2	

Ignition Timing

NOTE

- The ignition control module (ICM) system is factory pre-set and cannot be adjusted. Ignition timing inspection procedures are given to inspect the function of the ignition control module (ICM) components.
- If the timing appears wrong, check another spark plug wire for confirmation.

Warm up the engine to operating temperature.

⚠ WARNING

- **If the engine must be running to do some work, make sure the area is well-ventilated. Never run the engine in an enclosed area.**
- **The exhaust contains poisonous carbon monoxide gas that may cause loss of consciousness and may lead to death.**

Stop the engine and remove the timing hole cap.

Connect a timing light to the spark plug wire.
Start the engine and let it idle.

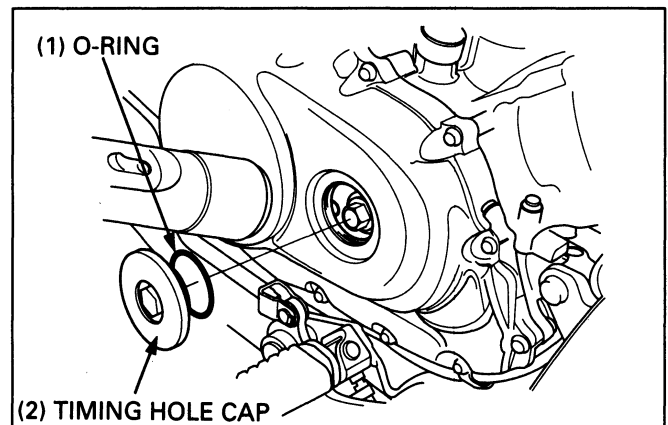

The timing is correct if the "F" mark aligns with the index mark on the right crankcase cover.

Increase the engine speed by rotating the throttle stop screw knob and make sure the "F" mark begins to move counterclockwise at approximately 2,000 rpm.

Check the timing hole cap's O-ring for damage, replace the new one if desired.

Apply grease to the threads, and install the timing hole cap.

Torque: 18 N·m (1.8 kg·m, 13 ft·lb)

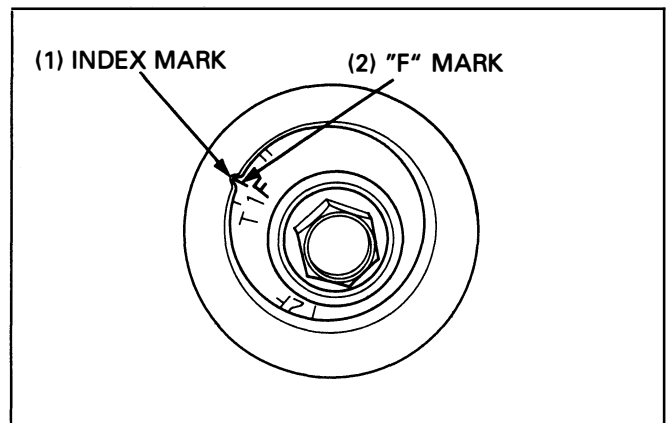

17. Electric Starter/Starter Clutch

Service Information	17-1	Starter Motor Disassembly/Assembly	17-8
System Location	17-2	Starter Clutch Removal/Installation	17-10
Troubleshooting	17-3	Starter Clutch Disassembly/Assembly	17-12
Starter Motor Removal/Installation	17-7		

Service Information

⚠ WARNING

- **Always turn the ignition switch OFF before servicing the starter motor. The motor could suddenly start, causing serious injury.**

- A weak battery may be unable to turn the starter motor quickly enough, or supply adequate ignition current.
- If current is applied to the starter motor while the engine is not turning over, the starter motor may be damaged.
- For the following components inspections, refer to the Common Service Manual or the following pages; for the parts locations, see page 17-2 of this manual (System Location).

Component	Inspection method	Remarks
Clutch switch diode	Section 24 of the Common Service Manual	
Starter motor	Section 24 of the Common Service Manual	
Clutch switch	Section 25 of the Common Service Manual	
Neutral switch	Section 25 of the Common Service Manual	Torque: 12 N·m (1.2 kg-m, 9 ft-lb)
Ignition switch	Check for continuity on the continuity chart of the Wiring Diagram, page 19-1.	
Side stand switch	See page 18-9.	

System Location

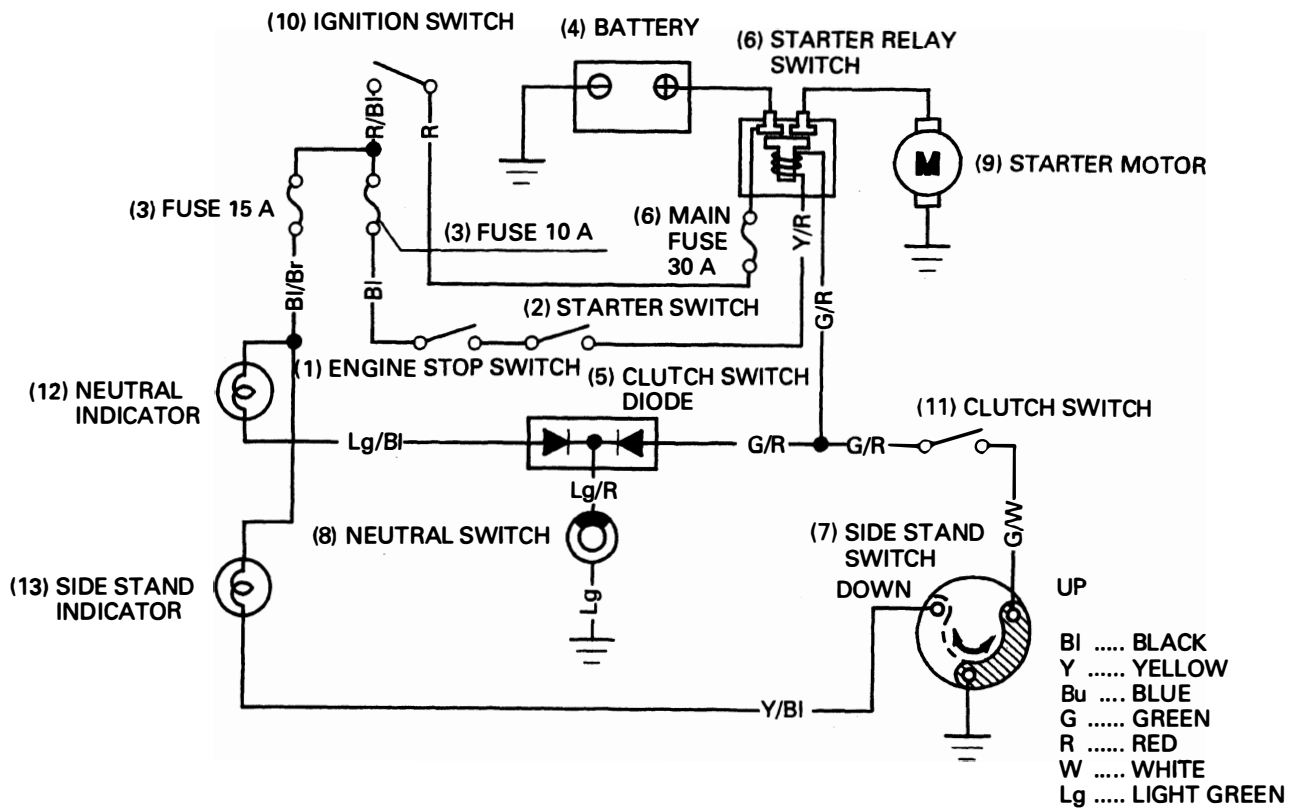
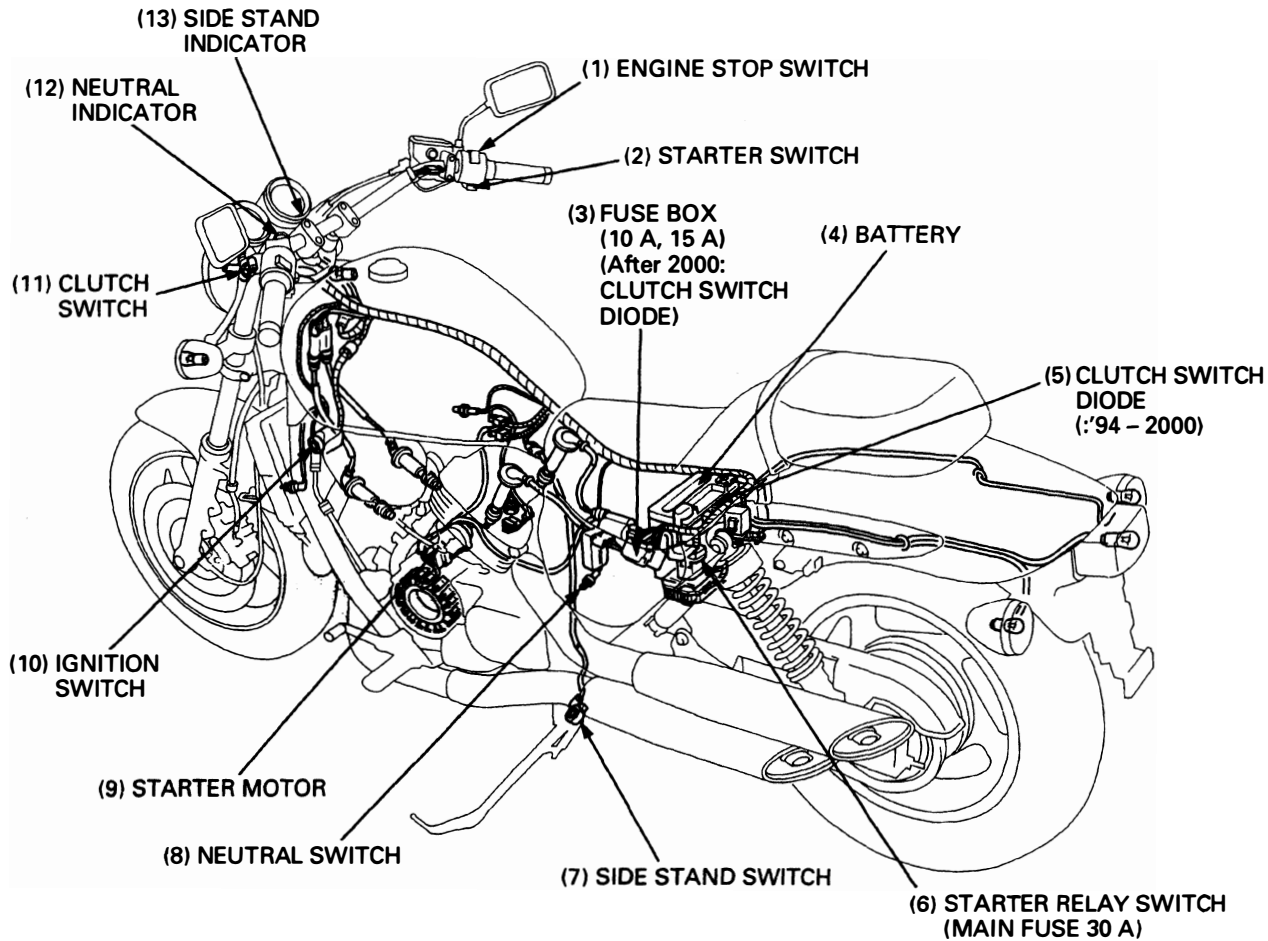

Troubleshooting

NOTE

- Check for the following before troubleshooting the system.
 - Blown main fuse (30 A) or sub fuse (10 A).
 - Loose battery and starter motor cable.
 - Discharged battery.

- The starter motor should operate when the transmission is in neutral.
- The starter motor should operate when the transmission is in any gear as indicated the chart below.

Gear Position	Side Stand	Clutch Lever	Starter Motor
In Any Gear	Up	Pulled in	Operates
		Released	Does Not Operate
	Down	Pulled in	Does Not Operate
		Released	Does Not Operate

Starter motor will not turn

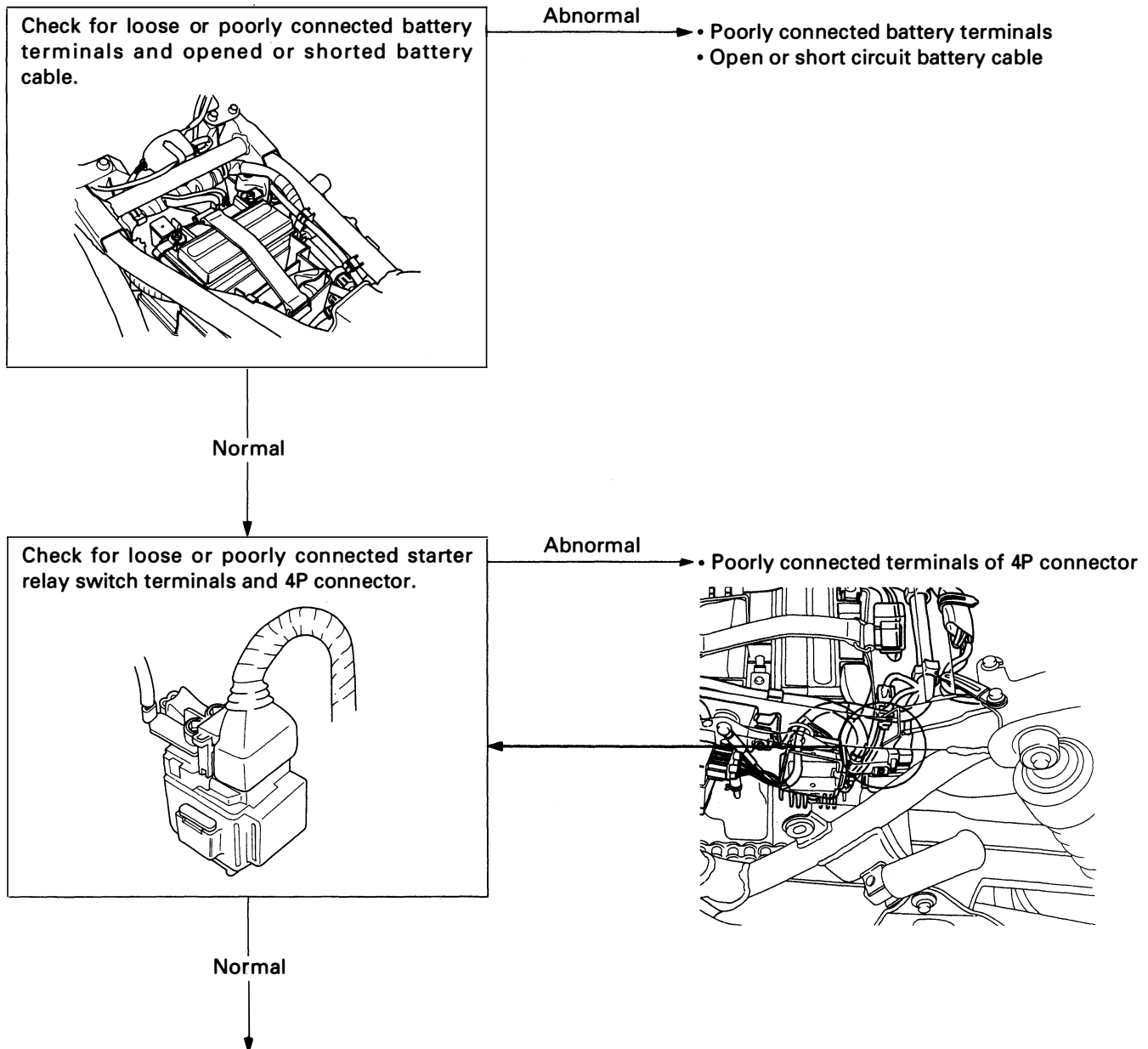

Electric Starter/Starter Clutch

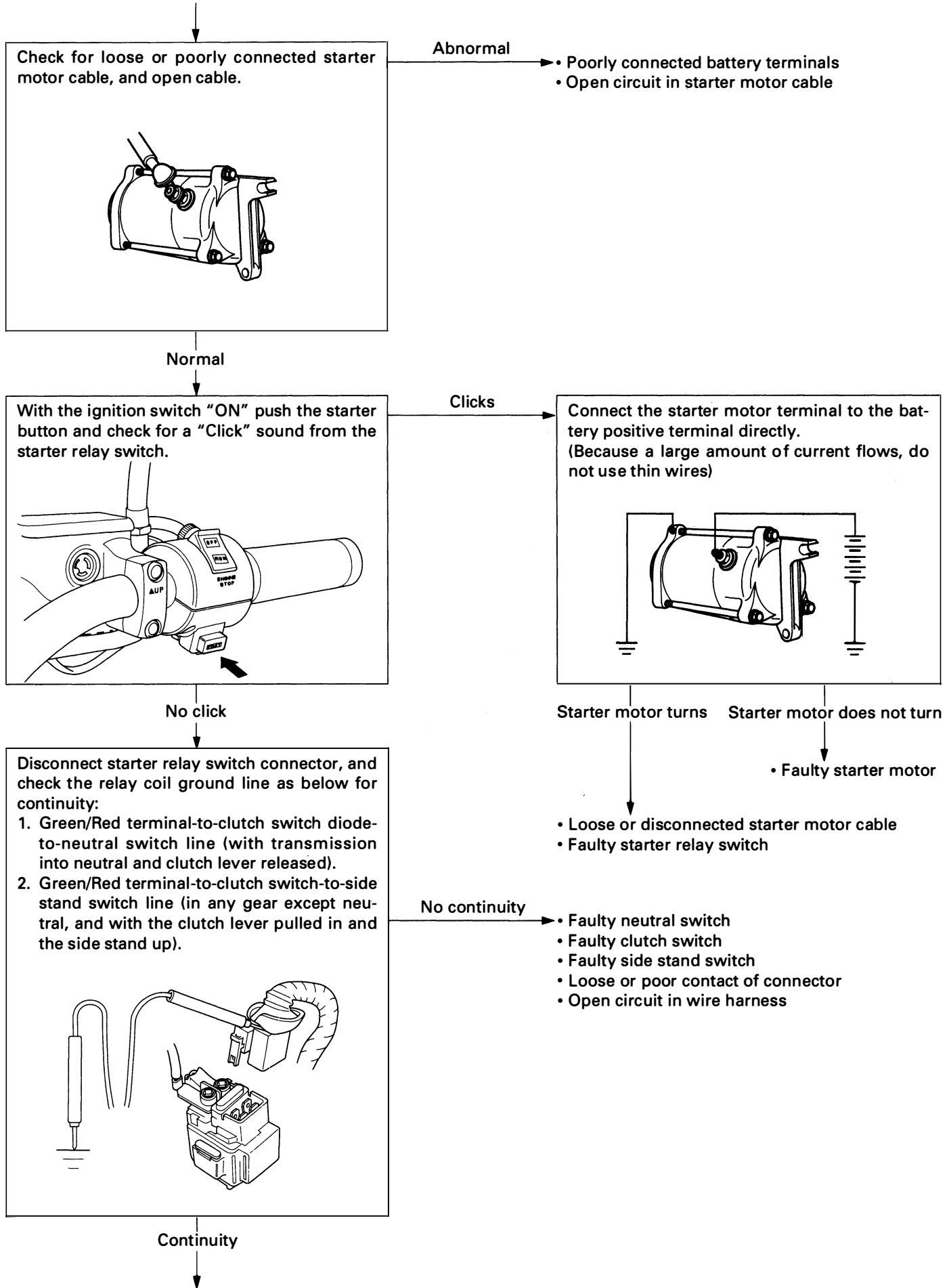

Connect the starter relay switch connector. With the ignition switch ON and the starter button pushed, measure the starter relay voltage at the starter switch connector.

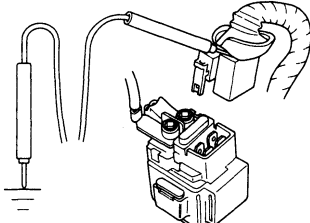

Connection: Yellow/Red (+) – Body ground (-)
Standard: Battery voltage

No Voltage →

- Faulty ignition switch
- Faulty engine stop switch
- Faulty starter switch
- Blown out main or sub fuses
- Loose or poor contact of connector
- Open circuit in wire harness

Battery voltage registers

Remove the starter relay switch. Connect a fully charged 12 V battery to the starter relay switch. Check the continuity between the switch large terminal.

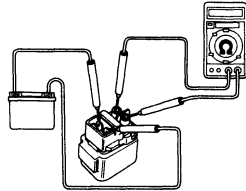

Battery Connection: Yellow/Red (+) – Green/Red (-)
Standard: Continuity

Normal →

- Loose or poor contact of the starter relay switch connector

Abnormal →

- Faulty starter relay switch

Starter motor turns when the transmission is in neutral, but does not turn with transmission in any gear with the side stand up, and the clutch lever pulled in.

Check that the side stand switch is operating properly with the ignition ON.

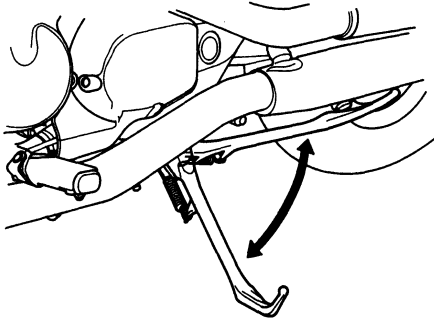

Abnormal →

- Faulty side stand switch
- Burnt bulb
- Open circuit in wire harness

Normal

Electric Starter/Starter Clutch

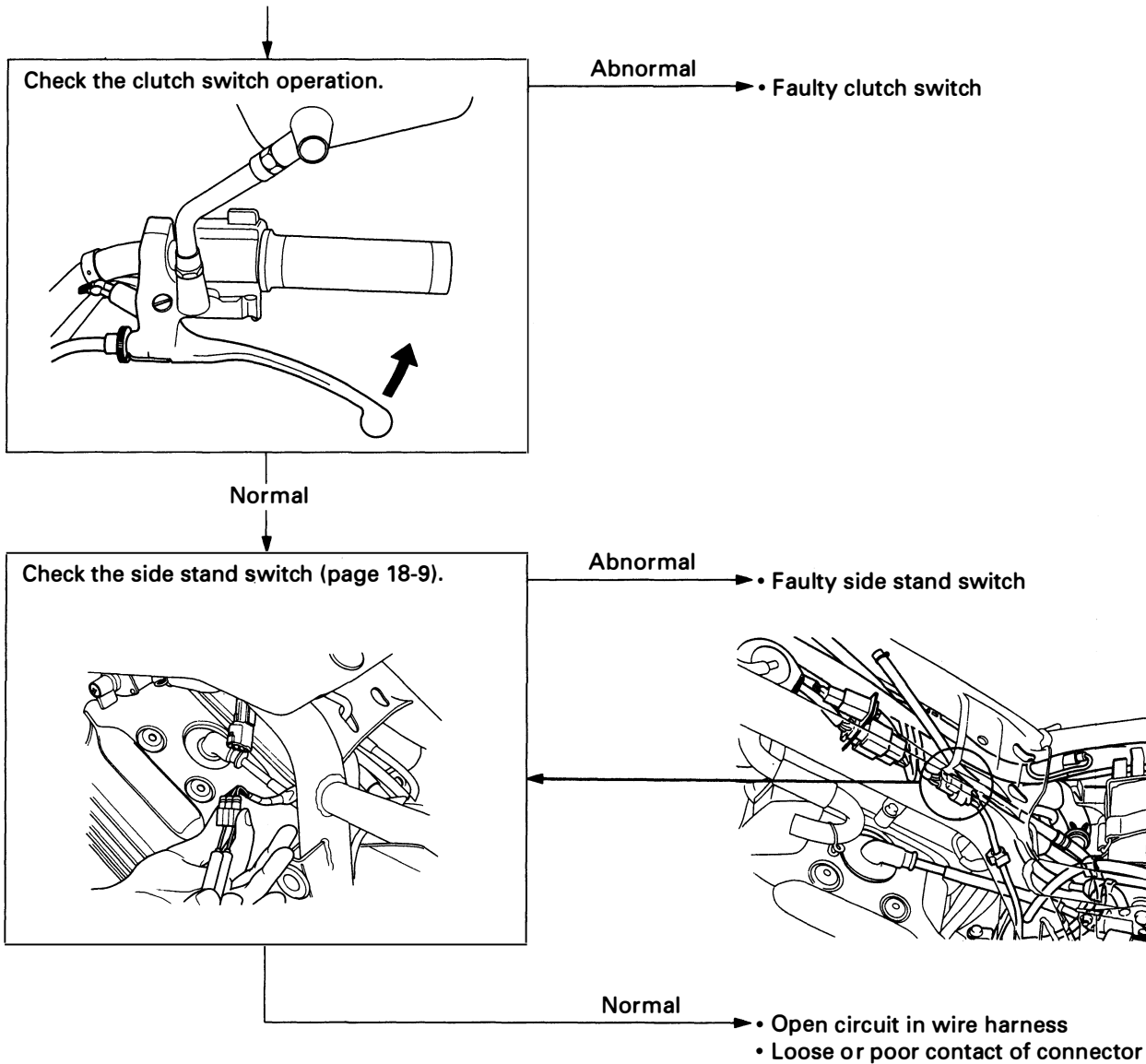

Starter motor turns slowly

- Low specific gravity in battery (or dead battery)
- Poorly connected battery terminal cable
- Poorly connected starter motor cable
- Faulty starter motor

Starter motor turns, but engine does not turn

- Starter motor is running backward
 - Case assembled improperly
 - Terminals connected improperly
- Faulty starter clutch
- Damaged reduction gear

Starter relay switch "clicks", but engine does not turn over

- Crankshaft does not turn due to internal mechanical engine problem
- Excessive reduction gear friction

Starter Motor Removal/Installation

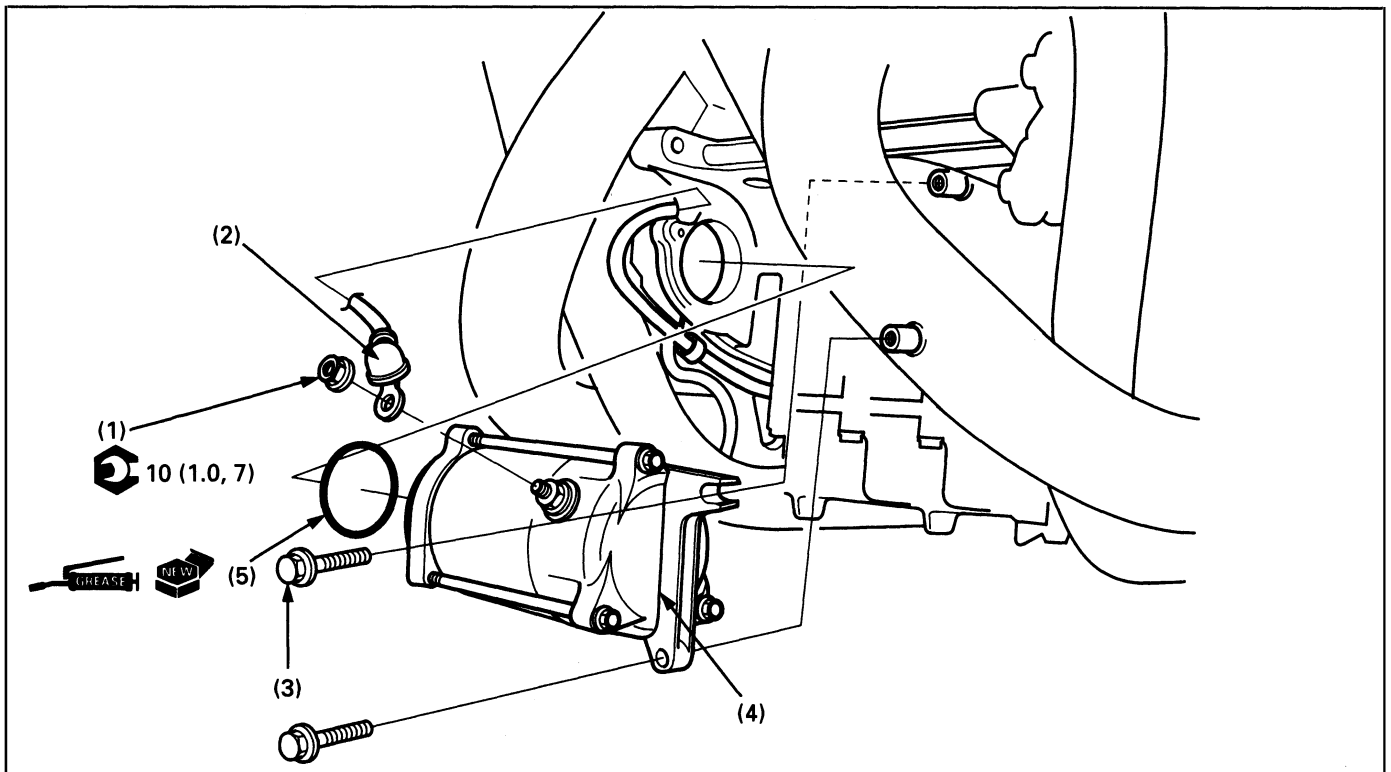

⚠ WARNING

- With the ignition switch OFF, remove the negative cable at the battery before servicing the starter motor.

NOTE

- Route the wire and cables properly (page 1-20).

Procedure		Q'ty	Remarks
Removal Order			Installation is in the reverse order of removal.
(1)	Flange nut	1	After installation, install the rubber cap.
(2)	Starter motor cable eyelet	1	
(3)	Starter motor mounting bolt	2	
(4)	Starter motor	1	Disassembly (page 17-8)
(5)	O-ring	1	Apply oil when installing.

Starter Motor Disassembly/Assembly

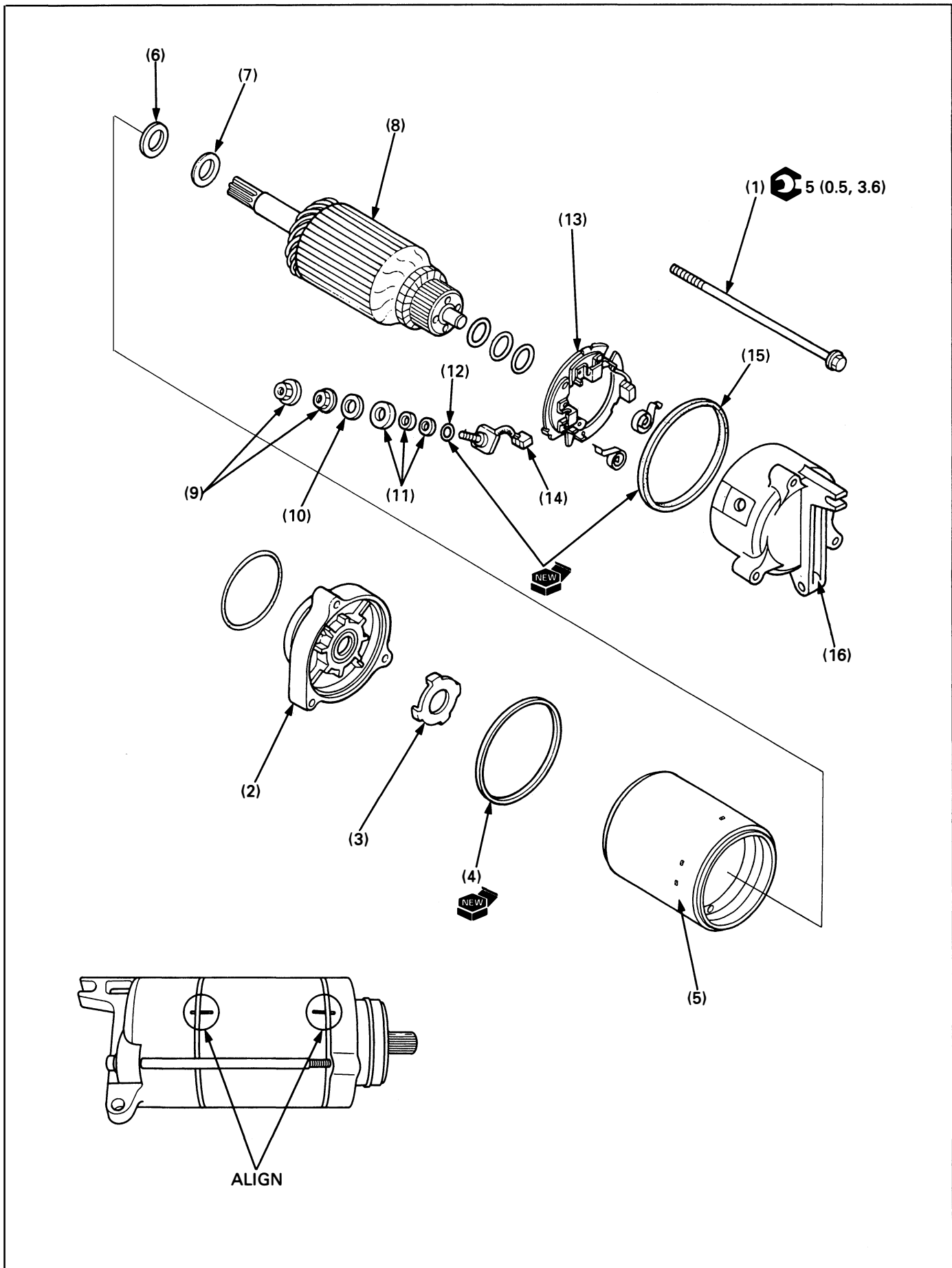

Requisite Service

- Starter motor removal/installation (page 17-7).

Procedure		Q'ty	Remarks
	Disassembly Order		Assembly is in the reverse order of disassembly.
(1)	Case bolt	3	
(2)	Front cover	1	Align the index marks on the front cover and case.
(3)	Lock washer	1	
(4)	O-ring	1	
(5)	Motor case	1	Align the index marks on the rear cover and case.
(6)	Insulated washer	1	
(7)	Washer	1	
(8)	Armature	1	
(9)	Brush terminal holding nut	2	
(10)	Washer	1	
(11)	Insulated washer	3	
(12)	O-ring	1	
(13)	Brush holder assembly	1	Align the holder tab with the rear cover groove.
(14)	Brush and terminal	1	
(15)	O-ring	1	
(16)	Rear cover	1	

Starter Clutch Removal/Installation

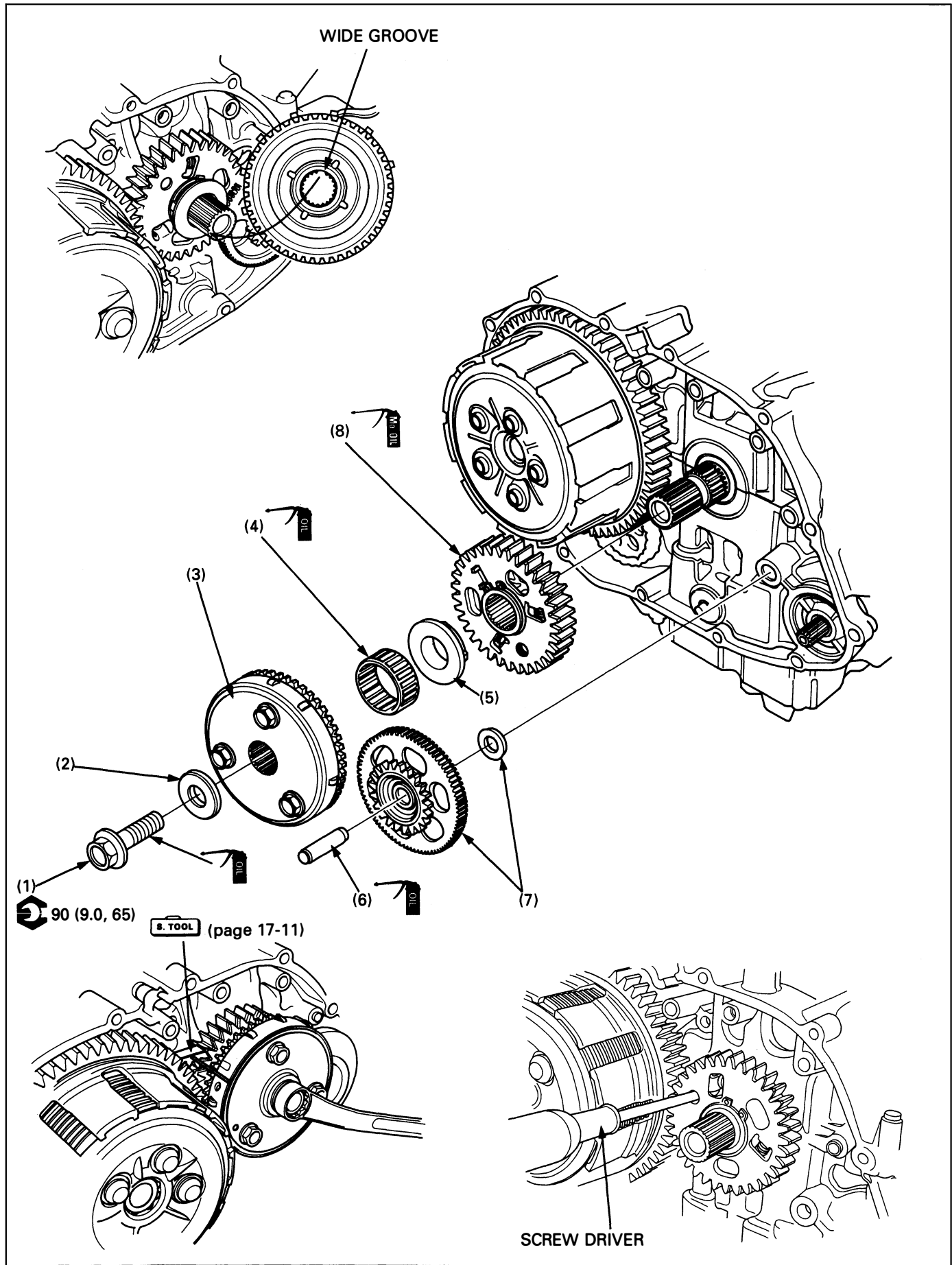

Requisite Service

- Right crankcase cover removal/installation (page 9-2)
- Pulse generator removal/installation (page 16-11)

Procedure		Q'ty	Remarks
(1)	Removal Order Starter clutch bolt	1	Installation is in the reverse order of removal. • Use the gear holder (07724 – 0010100) as shown. • Apply clean engine oil to the threads. • Disassembly/assembly (page 17-12) • At installation, align the wide groove with the wide tooth of the crankshaft. NOTE • When primary drive gear removal/installation, aligning the primary drive gear and sub-gear (anti-backlash gear) teeth with a screw driver.
(2)	Washer	1	
(3)	Starter clutch assembly	1	
(4)	Needle bearing	1	
(5)	Primary drive gear guide	1	
(6)	Starter reduction gear shaft	1	
(7)	Starter reduction gear/washer	1/1	
(8)	Primary drive gear assembly	1	

Starter Clutch Disassembly/Assembly

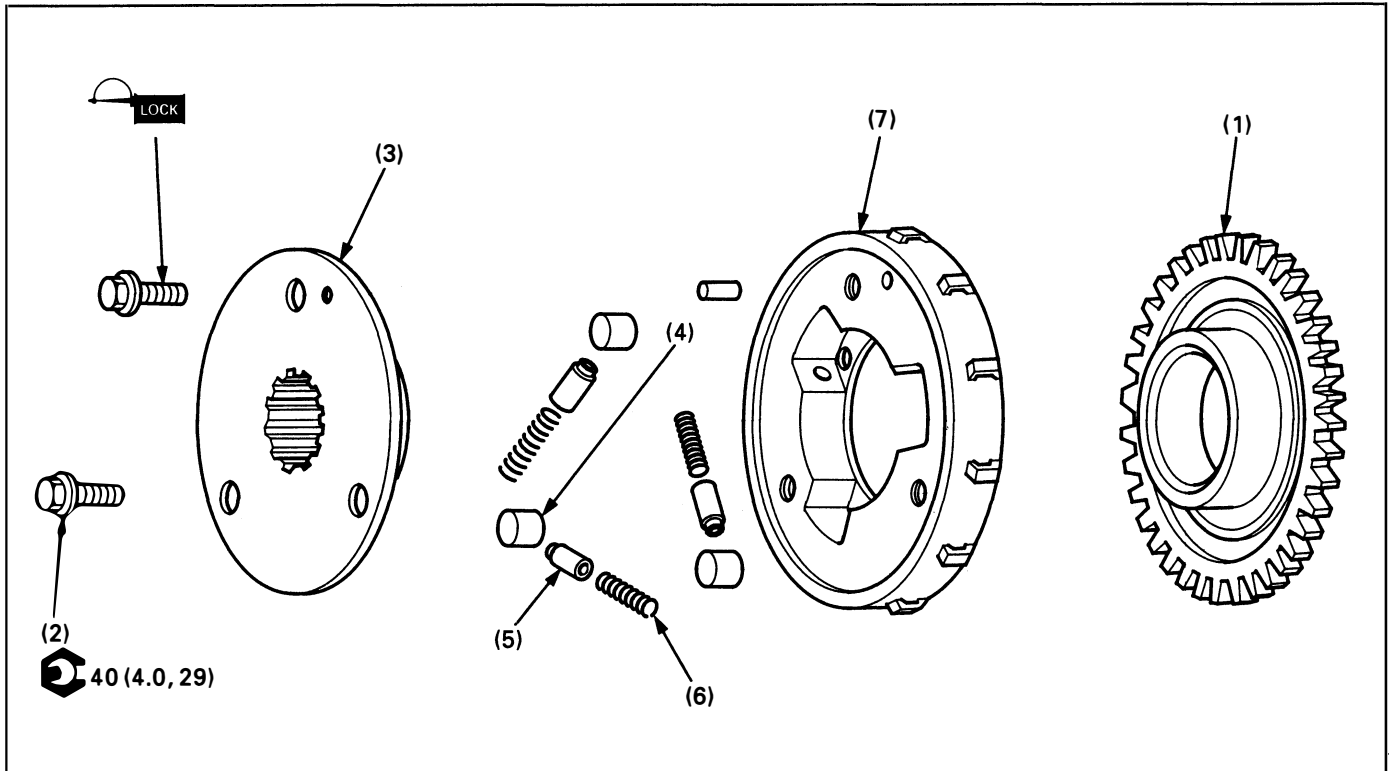

Requisite Service

- Starter clutch removal/installation (page 17-10).

Procedure	Q'ty	Remarks
Disassembly Order		Assembly is in the reverse order of disassembly.
(1) Starter driven gear	1	Rotate clockwise, when installing.
(2) Starter clutch outer cover bolt	3	Apply a locking agent to the threads at installation.
(3) Starter clutch outer cover	1	Align the pin on the outer with the hole of the cover when installing.
(4) Roller	3	Be careful not to pop them out.
(5) Plunger	3	
(6) Spring	3	
(7) Starter clutch outer	1	

18. Lights/Meters/Switches

Service Information	18-1	Combination Meter Disassembly/ Assembly	18-8
System Location	18-2	Ignition Switch Replacement	18-9
Troubleshooting	18-3	Side Stand Switch	18-9
Bulb Replacement	18-5		
Headlight Removal/Installation	18-6		
Combination Meter Removal/ Installation	18-7		

Service Information

⚠ WARNING

- A halogen headlight bulb becomes very hot while the headlight is ON, and remains hot for a while after it is turned OFF. Be sure to let it cool down before servicing.
 - Use an electric heating element and heated water/coolant mixture for the thermo sensor inspection. Keep all flammable materials away from the burner. Wear protective clothing, insulated gloves and adequate eye protection.
 - An improperly adjusted headlight may blind on-coming drivers, or it may fail to light the road for a safe distance.
- Note the following when replacing the halogen headlight bulb.
 - Wear clean gloves while replacing the bulb. Do not put finger prints on the headlight bulb, as they may create hot spots on the bulb and cause it to break.
 - If you touch the bulb with your bare hands, clean it with a cloth moistened with alcohol.
 - Be sure to install the dust cover after replacing the bulb.
 - All plastic connectors have locking tabs that must be released before disconnecting, and must be aligned and engaged fully when reconnecting.
 - Always turn off the ignition switch before disconnecting any electrical component.
 - A continuity test can be made with switches installed on the motorcycle.
 - Check the battery condition before performing any inspection that requires proper battery voltage.
 - For the following component locations see the Common Service Manual or page 18-2 of this manual (System Location); for inspections, refer to the applicable pages.

Component	Inspection method	Remarks
Front brake light switch	Section 25 of the Common Service Manual	
Horn	Section 25 of the Common Service Manual	
Handlebar switch	Check for continuity on the continuity chart of the Wiring Diagram, page 19-1	
Ignition switch		
Neutral switch	Section 25 of the Common Service Manual	Torque: 12 N·m (1.2 kg-m, 9 lb-ft) Apply sealant to the threads.
Oil pressure switch/ warning light	Section 25 of the Common Service Manual	Oil pressure check: Section 4 of the Common Service Manual. Torque: 12 N·m (1.2 kg-m, 9 lb-ft) Apply sealant to the threads.
Rear brake light switch	Section 25 of the Common Service Manual	
Turn signal lights	Section 25 of the Common Service Manual	

System Location

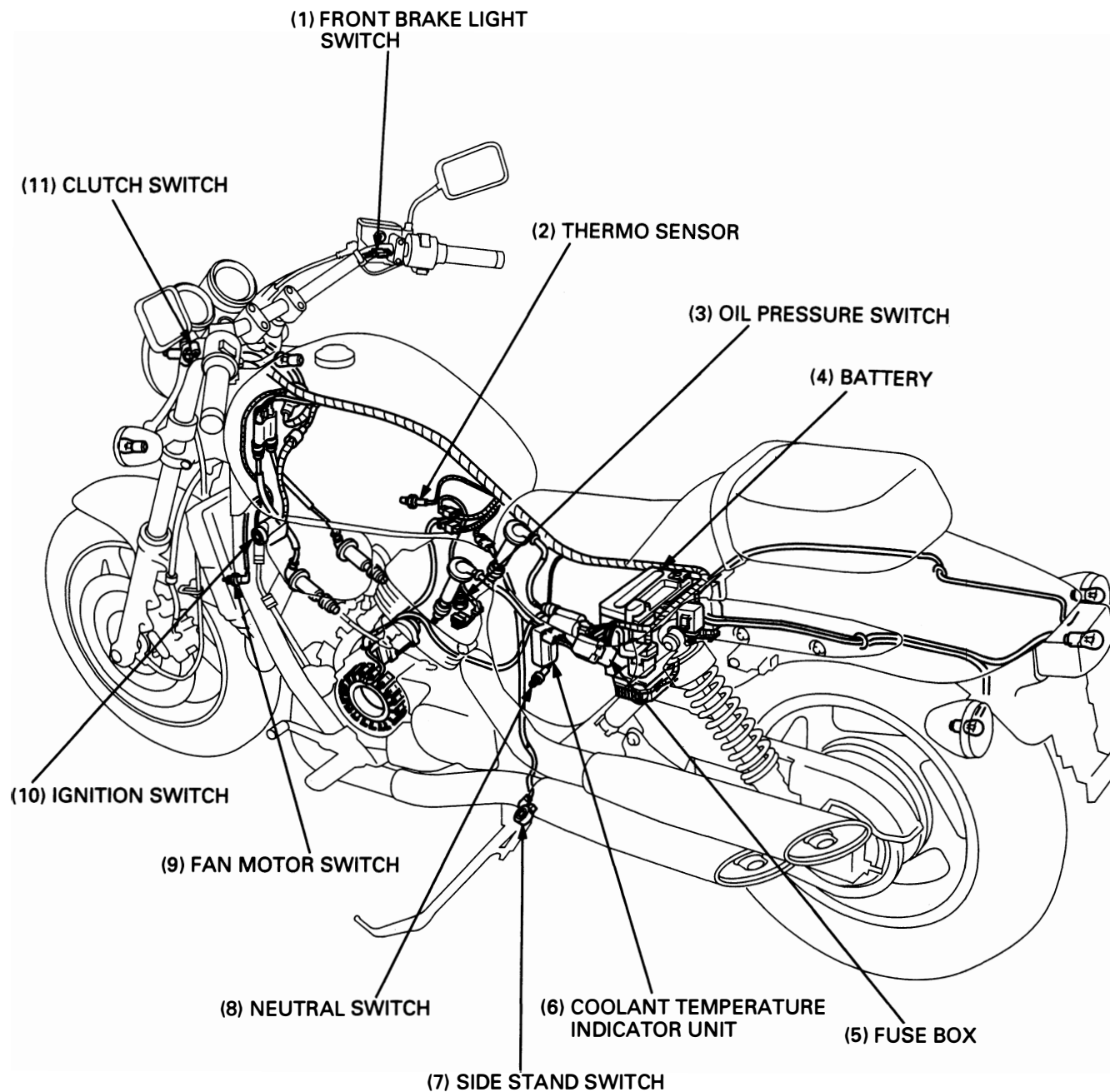

Troubleshooting

Coolant Temperature Indicator

- Turn the ignition switch ON, check that the temperature indicator light comes on for 3 seconds then goes out.

Coolant Temperature Indicator Remain ON

Disconnect the coolant temperature indicator connectors. Turn the ignition switch ON.

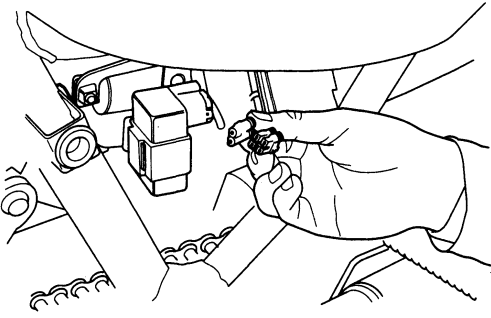

Indicator comes on

- Short circuit in Light green/Black wire

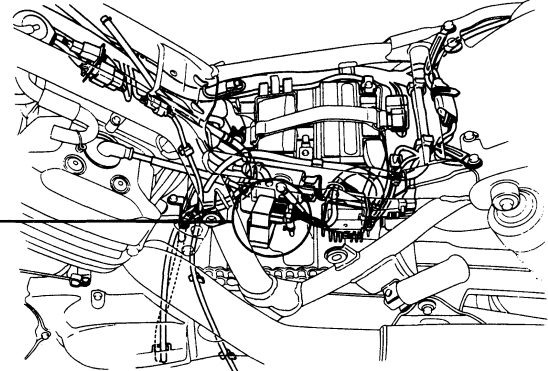

Indicator does not come on

Connect the coolant temperature indicator connectors. Disconnect the thermo sensor connector and turn the ignition switch ON. Check the coolant temperature indicator operation.

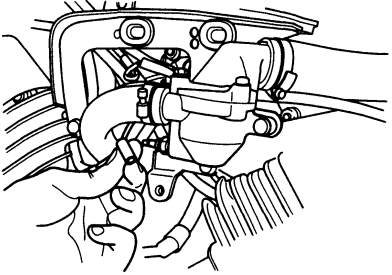

Normal

- Faulty thermo sensor (page 1-11)

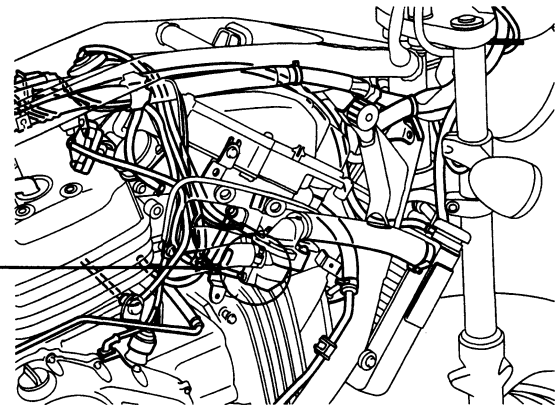

Abnormal

- Faulty coolant temperature indicator unit
- Short circuit in Green/Blue wire

Coolant Temperature Indicator Remains OFF

Disconnect the coolant temperature indicator connectors. Connect a jumper wire to the 4P connector and body ground, turn the ignition switch ON.

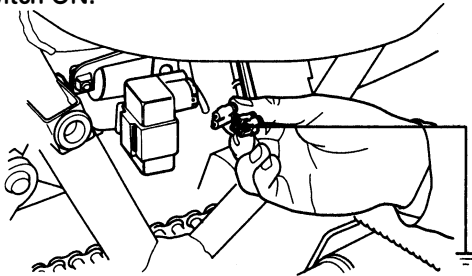

Connection: Light green/Black–Body ground

Indicator does not come on

- Blown indicator bulb
- Open circuit in Light green/Black wire

Indicator come on

Check the coolant temperature indicator 4P connector and body ground for continuity.



Connection: Green–Body ground
Standard: Continuity

Abnormal

- Open circuit in Green wire

Normal

Check the voltage between the coolant temperature indicator 4P connector and body ground, turn the ignition switch ON.



Connection: Black/Brown–Body ground
Standard: Battery voltage

Abnormal

- Open circuit in Black/Brown wire

Normal

- Faulty coolant temperature indicator unit

Bulb Replacement

Headlight Bulb

▲ WARNING

- A halogen headlight bulb becomes very hot while the headlight is ON, and remain hot for a while after it is turned OFF. Be sure to let it cool down before servicing.

Remove the headlight (page 18-6).
Push the retaining tabs and remove the headlight bulb socket. Remove the dust cover.

Unhook the bulb retainer and remove the headlight bulb.

Installation is in the reverse order of removal.

NOTE

- Install the dust cover with its "TOP" mark facing up.

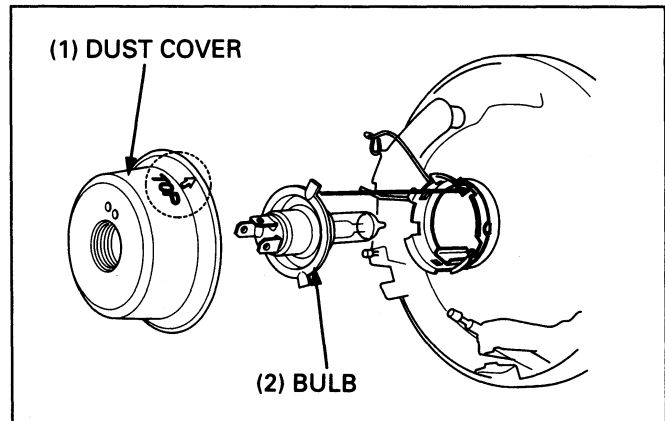
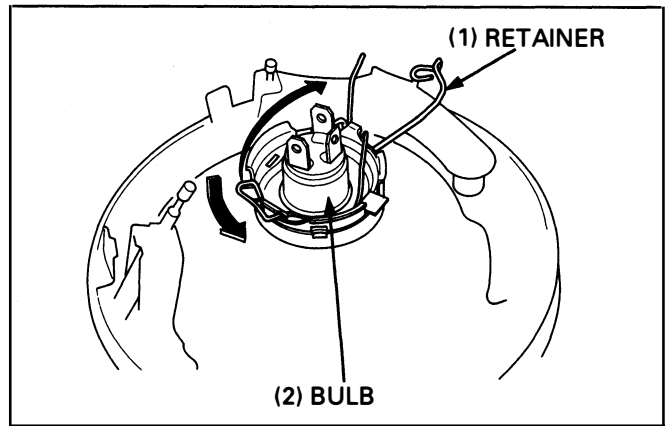

Tail/Brake Light Bulb

Remove the screws and tail/brake light lens.

Remove the tail/brake light bulb by turning it counterclockwise.

Install a new bulb in the reverse order of removal.

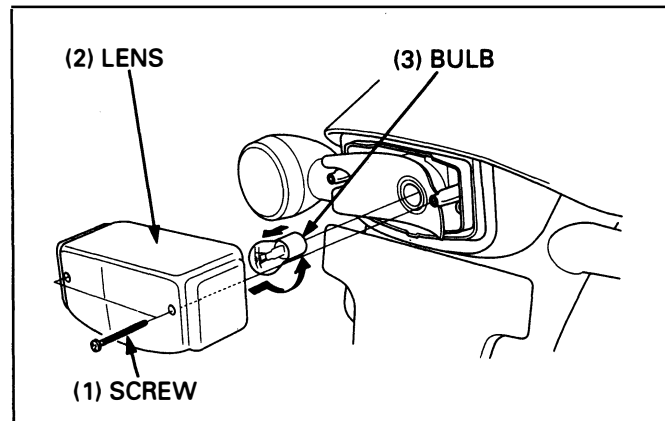

Turn Signal Light Bulb

Remove the screw and turn signal light lens.

Remove the turn signal light bulb by turning it counterclockwise.

Install a new bulb in the reverse order of removal.

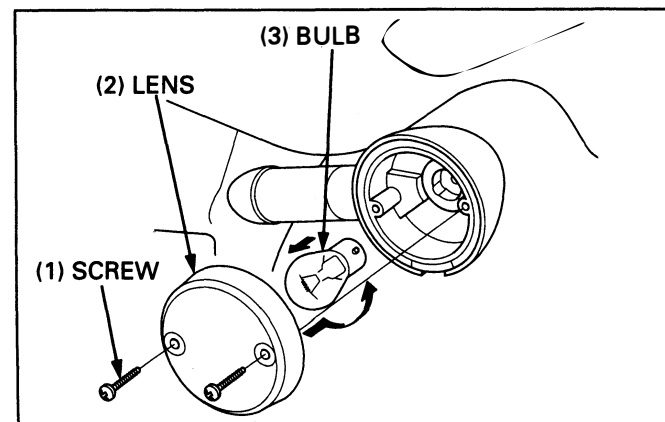

Headlight Removal/Installation

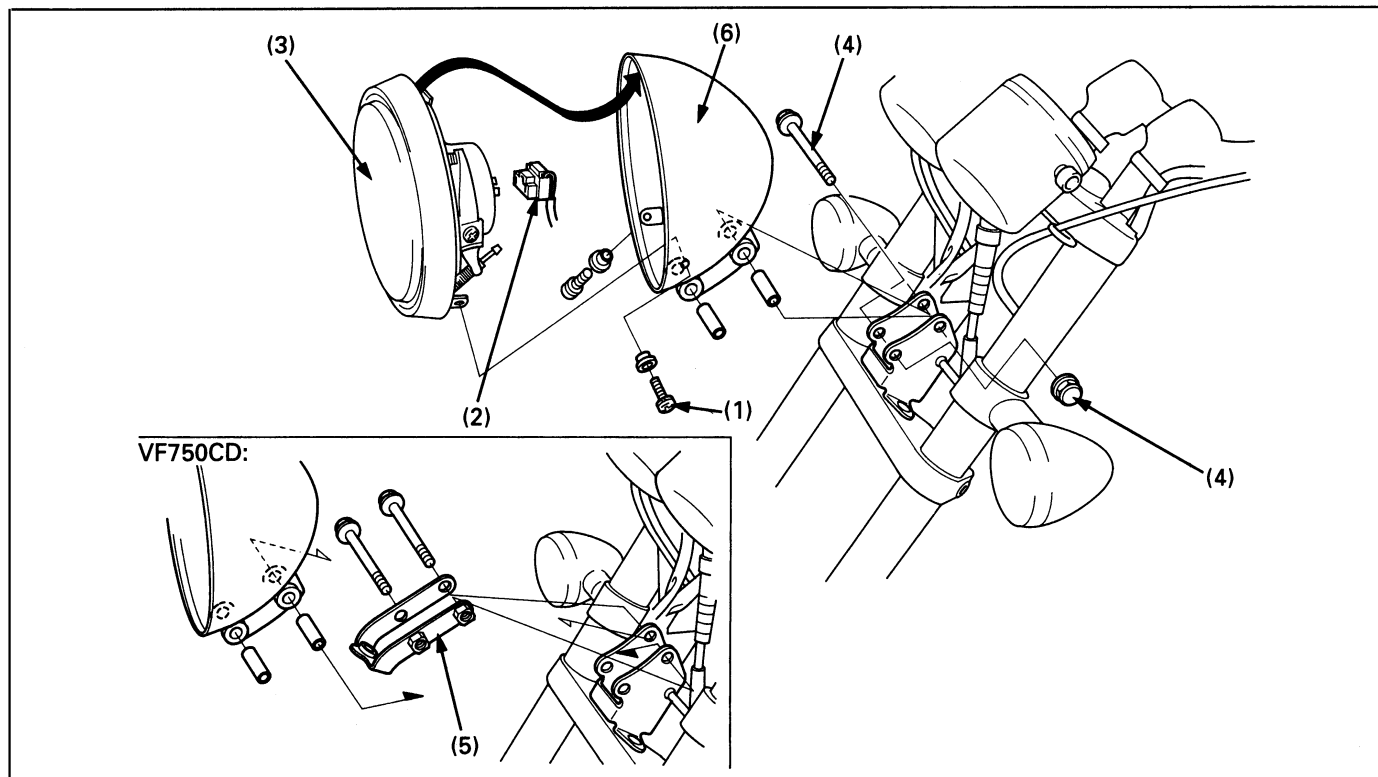

▲ WARNING

- An improperly adjusted headlight may blind on-coming drivers, or it may fail to light the road for a safe distance.

NOTE

- Adjust the headlight beam as specified by local laws and regulations.
- After installation, route the wires and cable properly (page 1-20).

Requisite Service

- Upper fairing removal/installation (VF750CD: page 2-8)

Procedure		Q'ty	Remarks
	Removal Order		Installation is in the reverse order of removal.
(1)	Screw	2	
(2)	Headlight connector	1	
(3)	Headlight assembly	1	
(4)	Headlight case bolt/nut	2/2	
(5)	Upper fairing stay	1	VF750CD only.
(6)	Headlight case	1	

Combination Meter Removal/Installation

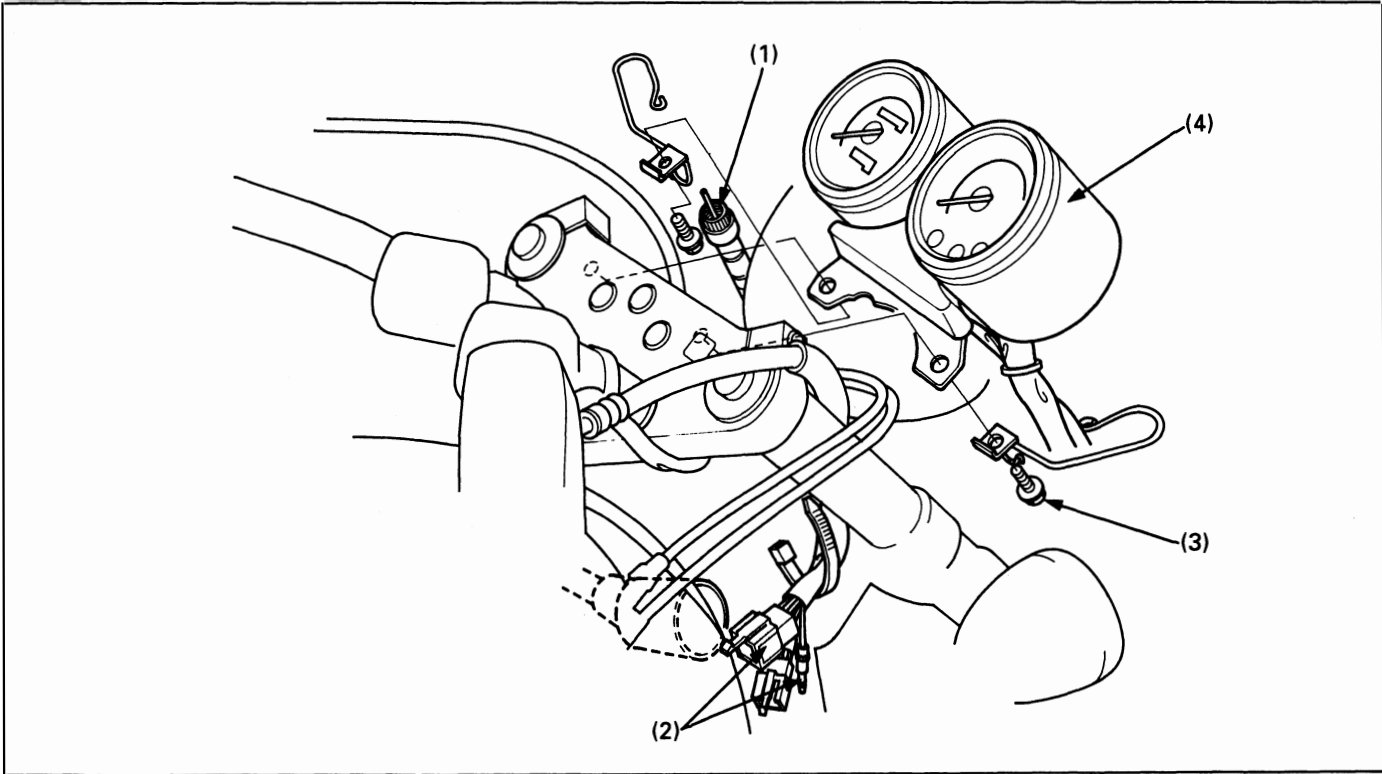

NOTE

- Route the wires and cables properly (page 1-20).

Requisite Service

- Front side cover removal/installation (page 2-3)
- Upper fairing removal/installation (VF750CD: page 2-8)

Procedure		Q'ty	Remarks
Removal Order			Installation is in the reverse order of removal.
(1)	Speedometer cable	1	
(2)	Combination meter connector	3	
(3)	Combination meter mounting bolt/guide	2/2	
(4)	Combination meter assembly	1	Disassembly/Assembly (page 18-8)

Combination Meter Disassembly/Assembly

Remove the screws and clamps.

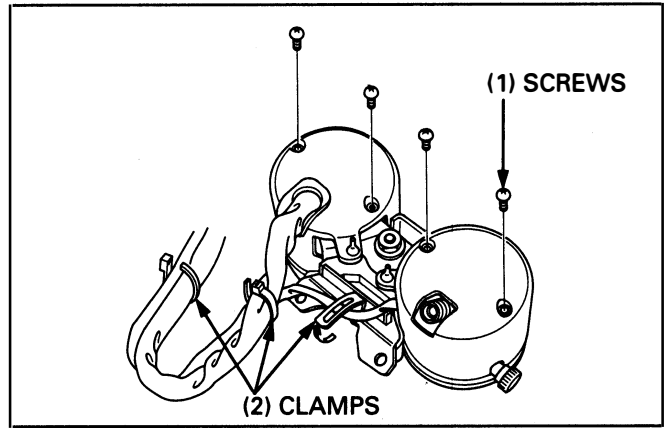

Remove the meter rear cover and meter stay.

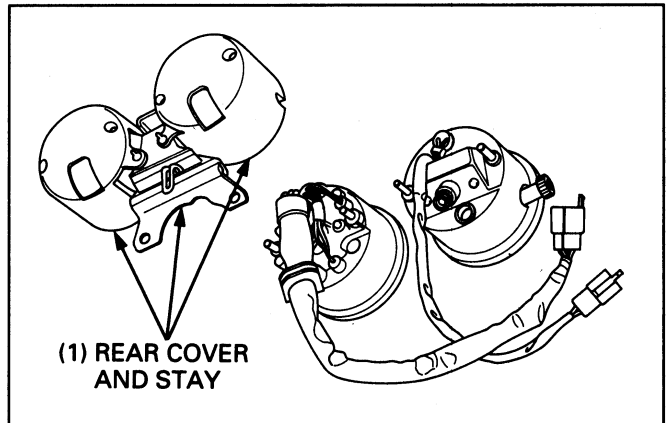

Pull the indicator bulbs out of the meter.
Remove the wire harness clamp.
Disconnect the meter terminals, and remove the wire harness.

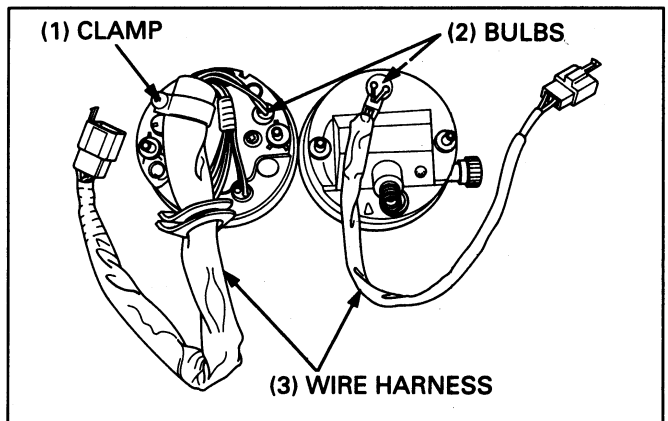

Separate the meter rear covers and meter stay.

Assemble the meters in the reverse order of disassembly.

NOTE

- Connect the proper color wire to the meter terminals.
Y/G: Yellow/Green **G: Green**

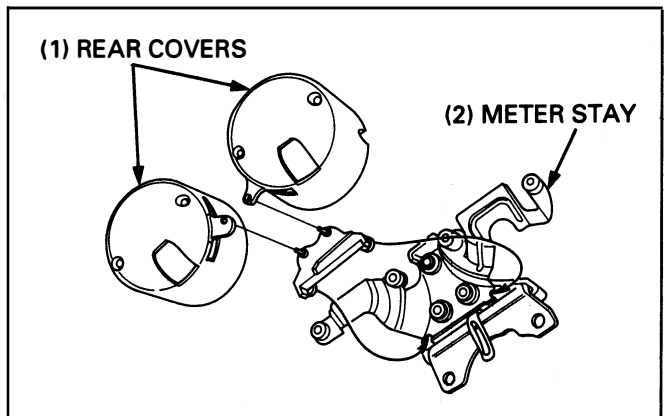

Ignition Switch Replacement

Remove the left middle cover stay assembly (page 5-4).

Remove the screw and ignition switch cover.
Remove the ignition switch mounting bolts using a drill, then remove the switch.

Install the new ignition switch and new mounting bolts.
Tighten the mounting bolts until the head twist off.

Install the left middle cover stay assembly (page 5-4).

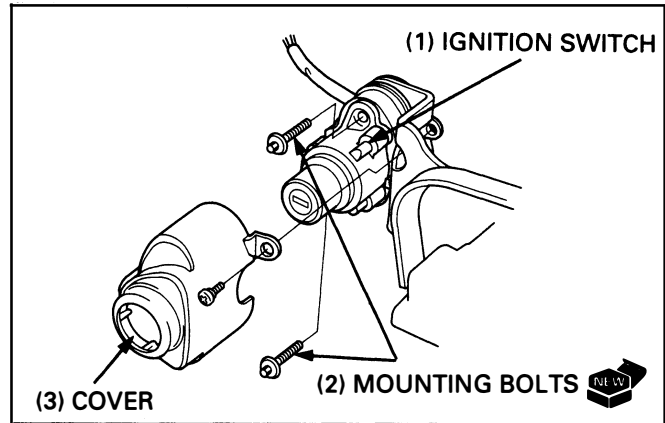

Side Stand Switch

Inspection

Disconnect the side stand switch 3P (Green) connector and check for continuity between each color of wire terminal as shown in the chart below.

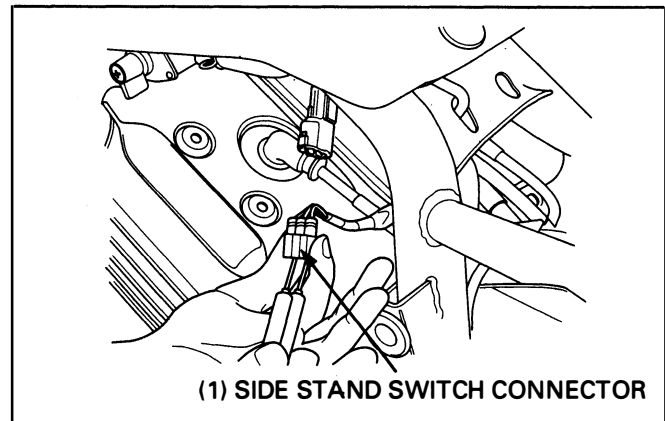

There should be continuity between the ○—○ positions on the following chart under the conditions shown here.

	Green/White	Yellow/Black	Green
Side stand up	○—		—○
Side stand down		○—	—○

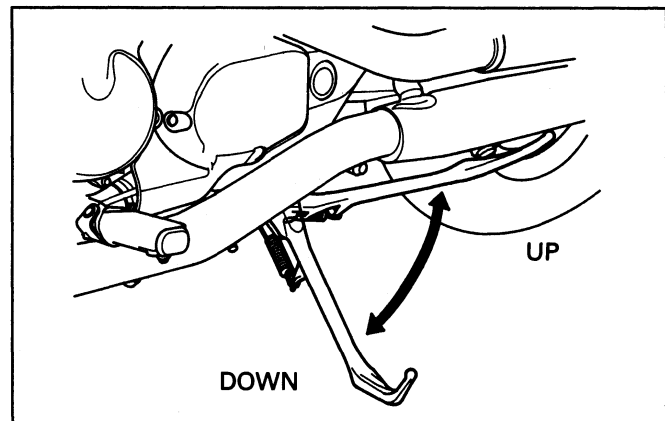

Removal/Installation

Disconnect the side stand switch 3P (Green) connector.

Remove the side stand switch mounting bolt and side stand switch.

Install the switch in the reverse order of removal.

Torque: 10 N·m (1,0 kg·m, 7 ft·lb)

NOTE

- Align the switch pin with the side stand hole and align the switch groove with the side stand return spring holding pin.

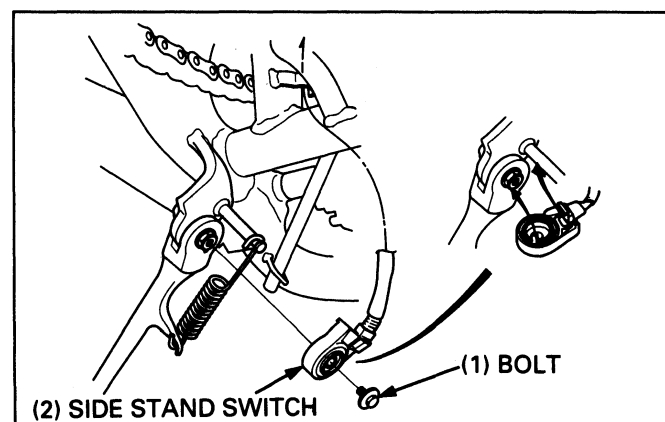

MEMO

19. Wiring Diagram

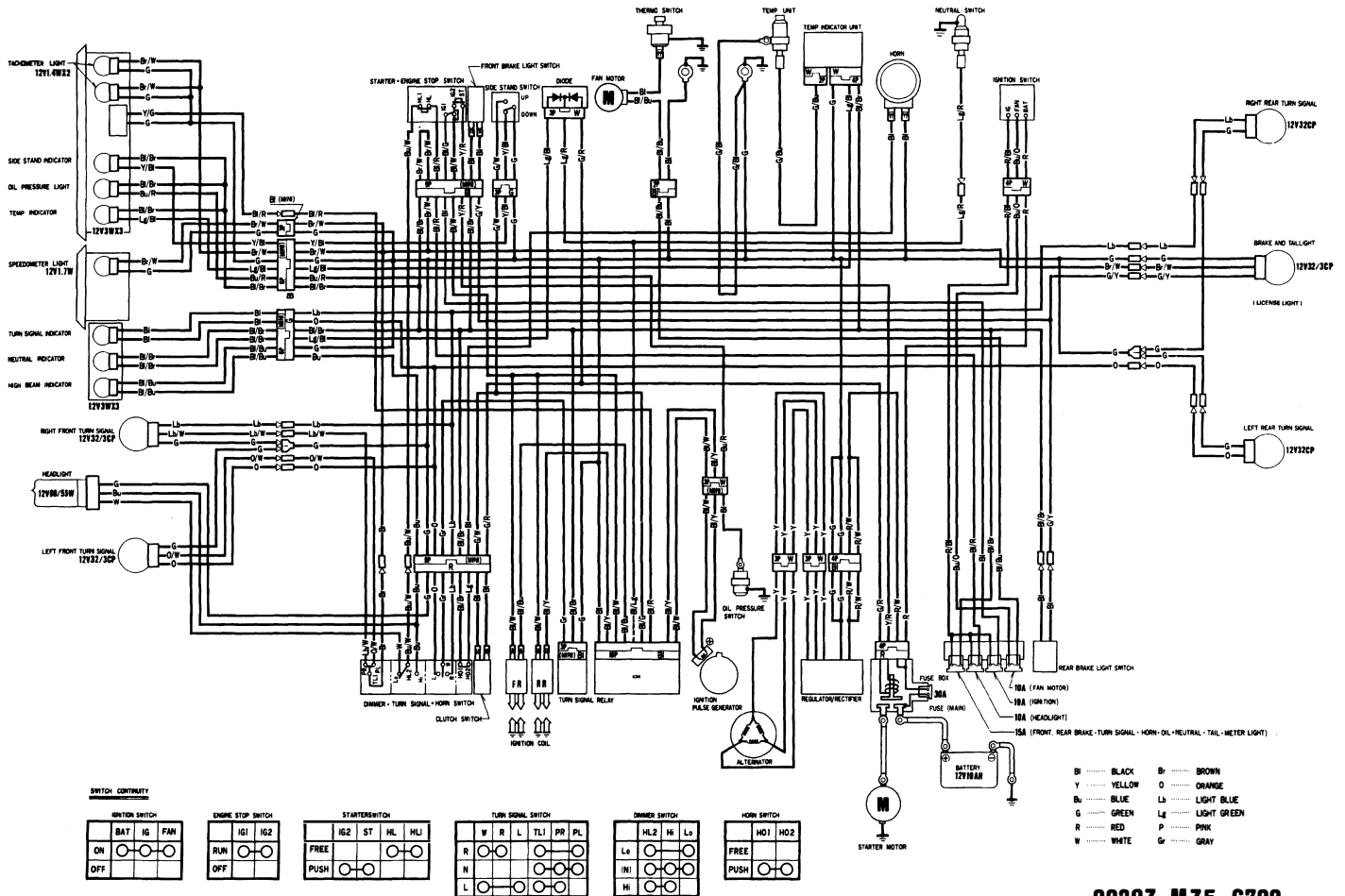

SWITCH CONTINUITY

IGNITION SWITCH			ENGINE STOP SWITCH			STARTER SWITCH			TURN SIGNAL SWITCH			DIMMER SWITCH			HORN SWITCH	
BAT	IG	FAN	IG1	IG2		IG2	ST	HL	R	W	L	HL2	H	Lh	HD1	HD2
ON	○	○	RUN	○	○	FREE	○	○	○	○	○	○	○	○	FREE	○
OFF	○	○	OFF	○	○	PUSH	○	○	N	○	○	○	○	○	PUSH	○
									L	○	○	○	○	○		

Bl	BLACK	B	BROWN
Y	YELLOW	O	ORANGE
Bu	BLUE	Lb	LIGHT BLUE
G	GREEN	Lg	LIGHT GREEN
R	RED	P	PINK
W	WHITE	Gr	GRAY

0030Z-MZ5-6700

After 2000:

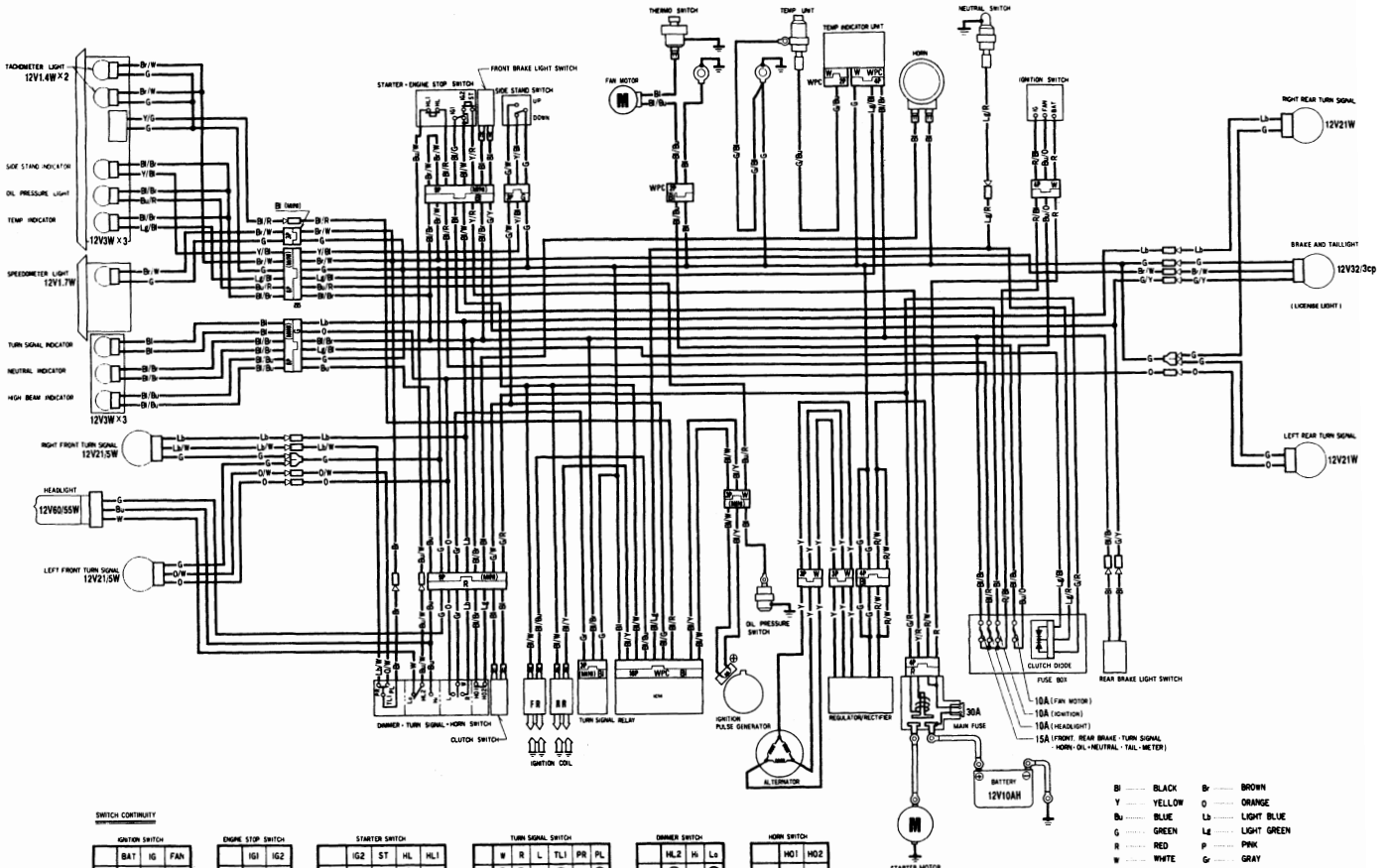

0030Z-MZ5-A800

20. Technical Feature

CT Bolt

Some parts of this motorcycle are tightened with the CT bolts, i.e. Combination Thread bolts which make the female threads when they screw in.

The lower half of the CT bolt features the combination of the standard threads and the low threads.

When the CT bolt is screwed into the unthreaded pilot hole, the bolt makes the female threads in the pilot hole by deforming the wall of the hole. Few chips and shavings are produced this time, which is different from threading by a machine.

NOTE

- When the CT bolt is reused, tighten the bolt with care not to ruin the female threads that were made when the bolt was tightened first time.
- The standard bolt is applicable to the female threads that were made by means of the plastic deformation during tightening the CT bolt.
- The service replacement parts of the parts tightened with the CT bolts have the threads.

When the CT bolt replacement is required, use new CT bolt or Honda genuine standard bolt (length ℓ).

CAUTION

- Do not use the length ℓ' standard bolt.

Application list

Parts	Bolt	Qty
Breather case, Rear cylinder head cover	M6	6
Cylinder head fin, Cylinder head	M6	12
Oil pump	M6	3
Water pump	M6	3

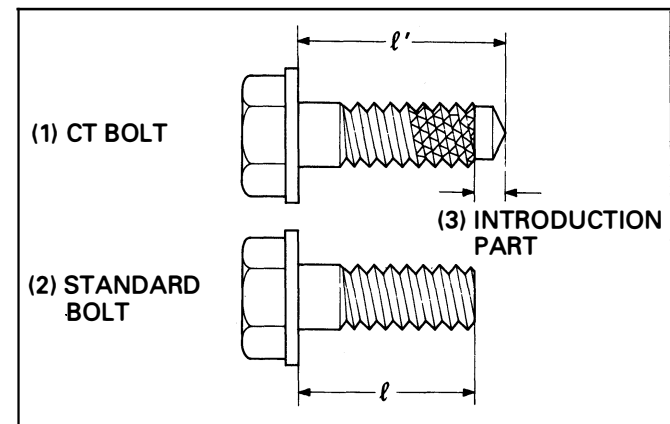
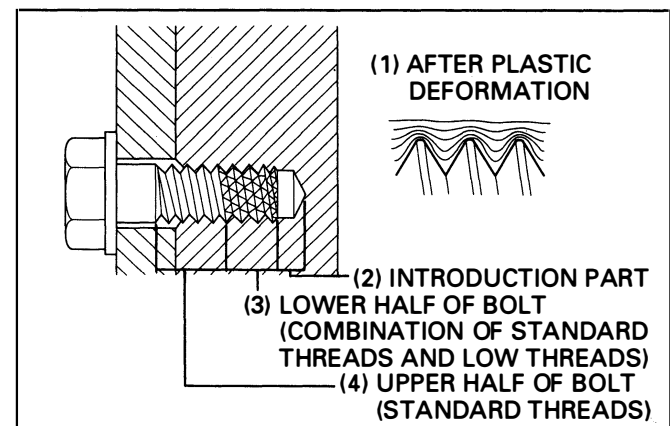
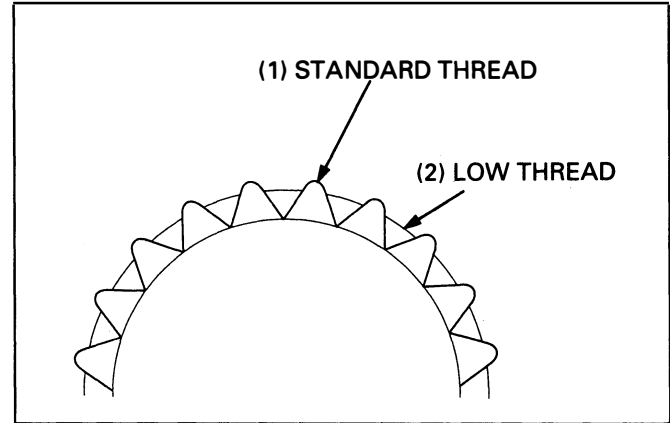

MEMO

21. Troubleshooting

Engine Does Not Start Or Is Hard To Start	21-1	Poor Performance At High Speed	21-4
Engine Lacks Power	21-2	Poor Handling	21-4
Poor Performance At Low And Idle Speeds	21-3		

Engine Does Not Start Or Is Hard To Start

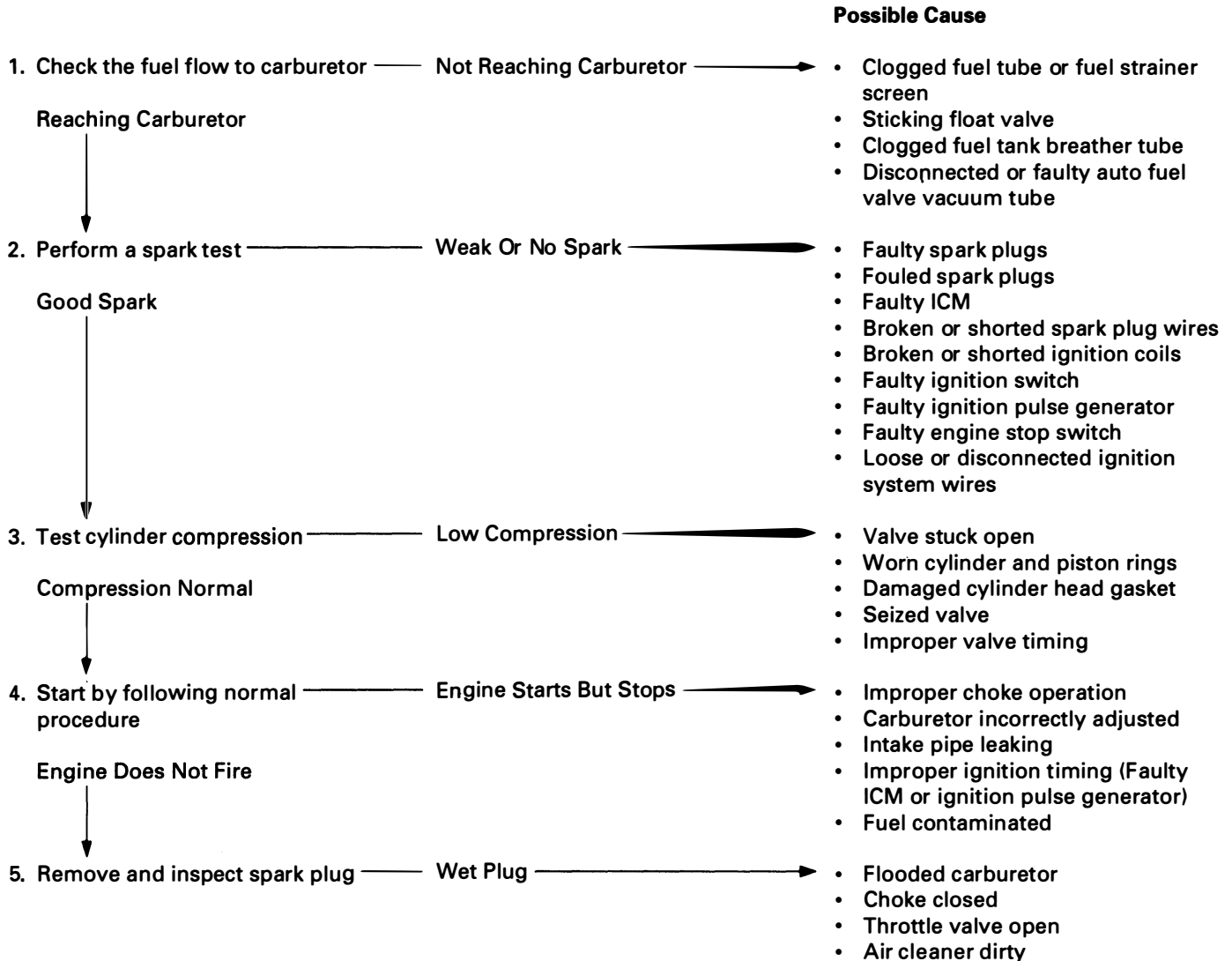

Engine Lacks Power

Possible Cause

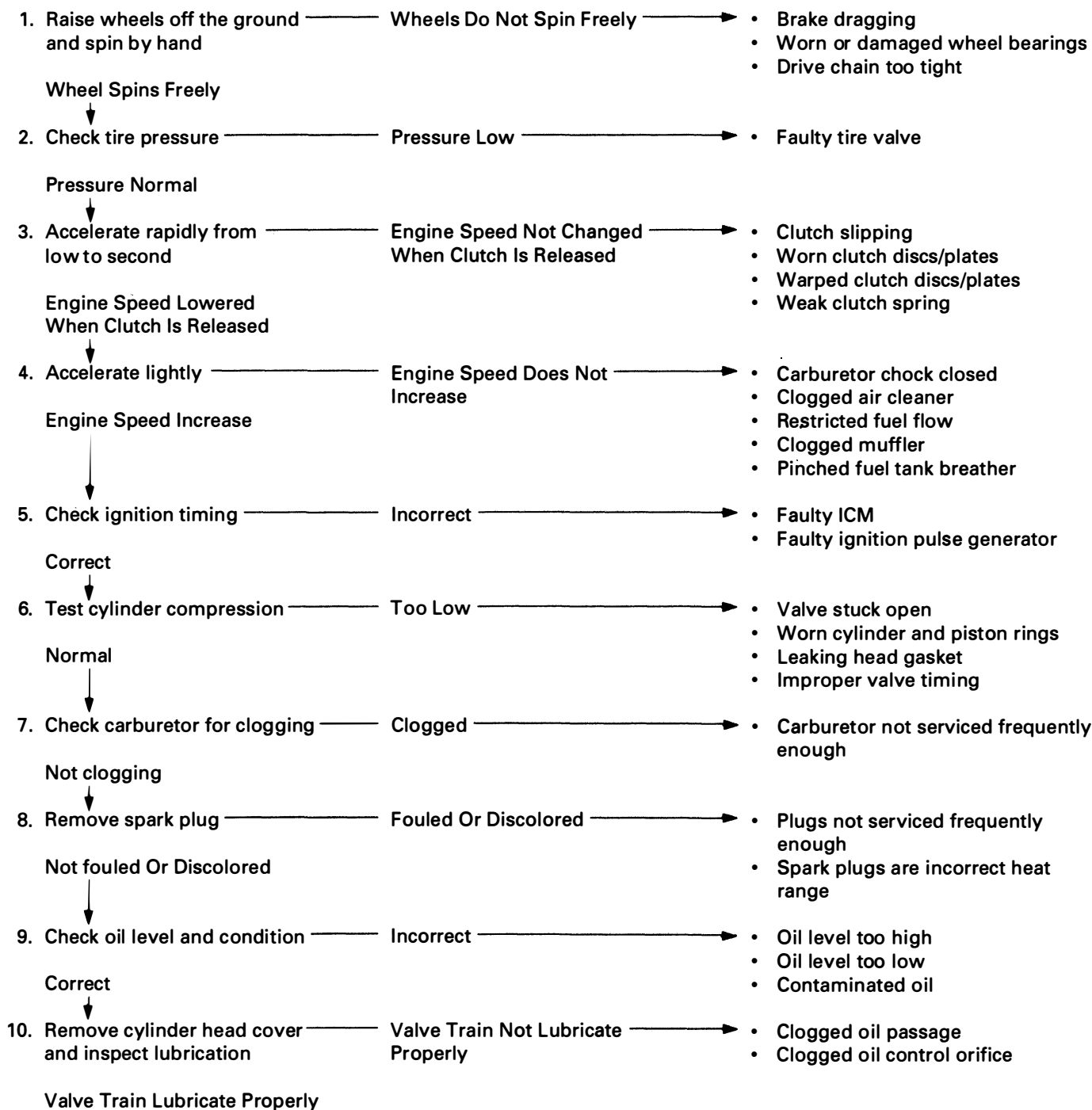

Possible Cause

- | | | |
|--|---|--|
| <p>11. Check for engine overheating ————— Overheating —————▶</p> <p style="margin-left: 20px;">Not Overheating</p> <p style="margin-left: 20px;">↓</p> | <p>12. Accelerate or run at high speed ————— Engine Knocks —————▶</p> <p style="margin-left: 20px;">Engine Does Not Knock</p> | <ul style="list-style-type: none"> • Excessive carbon built-up in combustion chamber • Use of poor quality fuel • Clutch slipping • Lean fuel mixture • Wrong type of fuel
<ul style="list-style-type: none"> • Worn piston and cylinder • Wrong type of fuel • Excessive carbon built-up in combustion chamber • Ignition timing too advanced (Faulty ICM) • Lean fuel mixture |
|--|---|--|

Poor Performance At Low And Idle Speeds

Possible Cause

- | | | | | |
|--|--|--|---|---|
| <p>1. Check ignition timing ————— Incorrect —————▶</p> <p style="margin-left: 20px;">Correct</p> <p style="margin-left: 20px;">↓</p> | <p>2. Check carburetor pilot screw adjustment ————— Incorrect —————▶</p> <p style="margin-left: 20px;">Correct</p> <p style="margin-left: 20px;">↓</p> | <p>3. Check for leaking intake pipe ————— Leaking —————▶</p> <p style="margin-left: 20px;">No Leak</p> <p style="margin-left: 20px;">↓</p> | <p>4. Perform spark test ————— Weak Or Intermittent Spark —————▶</p> <p style="margin-left: 20px;">Good Spark</p> | <ul style="list-style-type: none"> • Improper ignition timing (Faulty ICM)
<ul style="list-style-type: none"> • See Fuel System section
<ul style="list-style-type: none"> • Loose insulator clamps • Damaged insulator
<ul style="list-style-type: none"> • Faulty carbon or wet fouled spark plug • Faulty ICM • Faulty ignition coil • Broken or shorted spark plug wires • Faulty engine stop switch • Faulty ignition pulse generator |
|--|--|--|---|---|

Poor Performance At High Speed

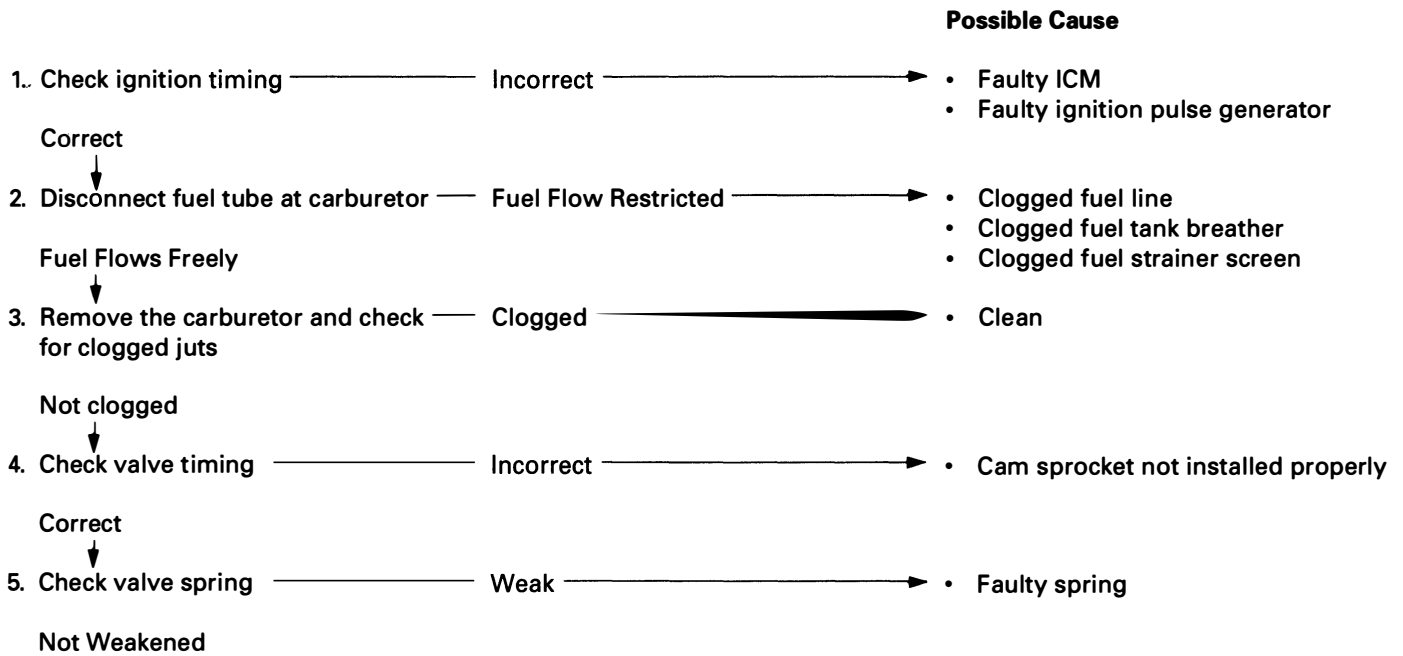

Poor Handling

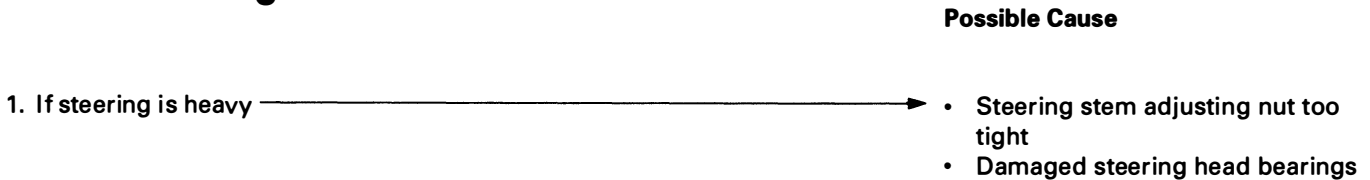

22. Index

Air Cleaner	3-5	Ignition control Module (ICM)	
Housing Removal/Installation	5-3	Removal/Installation	16-10
Alternator	15-9	Ignition Pulse Generator Inspection	16-9
Removal/Installation	15-10	Removal/Installation	16-11
Battery Removal/Installation	15-5	Ignition Switch Replacement	18-9
Brake Pedal Removal/Installation	14-8	Ignition System Inspection	16-8
Bulb Replacement	18-5	Ignition Timing	16-12
CT Bolt (Technical Feature)	20-1	Liquid Sealant Application	11-18
Cable & Harness Routing	1-20	Lubrication & Seal Points	1-17
Camshaft Installation	8-8	Lubrication System Diagram	4-2
Removal	8-2	Mainshaft Disassembly/Assembly	11-10
Carburetor Combination	5-10	Maintenance Schedule	3-4
Disassembly/Assembly	5-8	Model Identification	1-3
Removal/Installation	5-4	Oil Pump Disassembly/Assembly	4-4
Separation	5-6	Removal/Installation	4-3
Synchronization	5-14	Pulse Secondary Air Injection Control Valve	
Tube Routing (California Type Only)	5-13	(PAIR Control Valve) Removal/Installation	
Charging System Inspection	15-6	(California Type Only)	5-18
Clutch Installation	9-6	Pilot Screw Adjustment	5-16
Removal	9-4	Piston Disassembly/Assembly	11-6
Combination Meter Disassembly/Assembly	18-8	Radiator Disassembly/Assembly	6-6
Removal/Installation	18-7	Removal/Installation	6-5
Connecting Rod Selection	11-18	Rear Brake Panel Disassembly/Assembly	14-7
Coolant Draining	6-3	Rear Fender Removal/Installation	2-7
Countershaft Disassembly/Assembly	11-12	Rear Wheel Disassembly/Assembly	13-4
Crankcase Bolt Location	11-18	Removal/Installation	13-2
Combination	11-14	Regulator/Rectifier	15-7
Separation	11-2	Right Crankcase Cover Removal/Installation	9-2
Crankshaft Bearing Replacement	11-16	Seat Removal/Installation	2-2
Crankshaft/Connecting Rod Removal/Installation	11-4	Service Access Guide	3-2
Cylinder Head Disassembly/Assembly	8-6	Service Information (Brake System)	14-1
Removal/Installation	8-4	(Charging System/Alternator)	15-1
Drive Chain	3-8	(Clutch System)	9-1
Drive Sprocket Cover Removal/Installation	10-2	(Cooling System)	6-1
Emission Control Information Labels		(Crankshaft/Piston/Transmission)	11-1
(U.S.A. Only)	1-30	(Cylinder Head/Valves)	8-1
Emission Control System	1-27	(Electric Starter/Starter Clutch)	17-1
Engine Removal/Installation	7-2	(Engine Removal/Installation)	7-1
Evaporative Emission Canister (EVAP Canister)		(Frame/Body Panels/Exhaust System)	2-1
Removal/Installation		(Front Wheel/Suspension/Steering)	12-4
(California Type Only)	5-18	(Fuel System)	5-1
Exhaust System Removal/Installation	2-4	(Gearshift Linkage)	10-1
Fork Assembly	12-10	(Ignition System)	16-1
Disassembly	12-8	(Lights/Meters/Switches)	18-1
Removal/Installation	12-6	(Lubrication System)	4-1
Front Brake Caliper Disassembly/Assembly	14-4	(Maintenance)	3-1
Removal/Installation	14-3	(Rear Wheel/Suspension)	13-1
Front Brake Pad Replacement	14-2	Shock Absorber Disassembly/Assembly	13-7
Front Master Cylinder Disassembly/Assembly	14-6	Removal/Installation	13-6
Removal/Installation	14-5	Side Cover Removal/Installation	2-3
Front Side Cover Removal/Installation	2-3	Side Stand Switch	18-9
Front Wheel Disassembly/Assembly	12-5	Specifications	1-4
Removal/Installation	12-4	Starter Clutch Disassembly/Assembly	17-12
Fuel Tank Removal/Installation	2-2	Removal/Installation	17-10
Gearshift Linkage Removal/Installation	10-4	Starter Motor Disassembly/Assembly	17-8
General Safety	1-1	Removal/Installation	17-7
Handlebar Removal/Installation	12-2	Steering Stem Removal/Installation	12-12
Headlight Aim	3-10	Swingarm Disassembly/Assembly	13-11
Removal/Installation	18-6	Removal/Installation	13-9
High Altitude Adjustment (U.S.A. Only)	5-17	System Flow Pattern	6-2
Ignition Coil Inspection	16-8		
Removal/Installation	16-9		

System Location (Charging System/Alternator)	15-2
(Electric Starter/Starter Clutch)	17-2
(Ignition System)	16-2
(Lights/Meters/Switches)	18-2
Thermostat Removal/Installation	6-4
Tools	1-15
Torque Values	1-12
Transmission Removal/Installation	11-8
Troubleshooting (Brake System)	14-1
(Charging System/Alternator)	15-3
(Clutch System)	9-1
(Cooling System)	6-1
(Crankshaft/Piston/Transmission)	11-1
(Cylinder Head/Valves)	8-1
(Electric Starter/Starter Clutch)	17-3
(Engine Does Not Start Or Is Hard To Start)	21-1
(Engine Lacks Power)	21-2
(Frame/Body Panels/Exhaust System)	2-1
(Front Wheel/Suspension/Steering)	12-1
(Fuel System)	5-2
(Gearshift Linkage)	10-1
(Ignition System)	16-3
(Lights/Meters/Switches)	18-3
(Lubrication System)	4-1
(Poor Handling)	21-4
(Poor Performance At High Speed)	21-4
(Poor Performance At Low And Idle Speeds) ...	21-3
(Rear Wheel/Suspension)	13-1
Upper Fairing Removal/Installation (VF750CD).....	2-8
Valve Clearance	3-5
Water Pump Removal/Installation	6-7
Wiring Diagram	19-1

23. Appendix: Part Numbers

Air Cleaner	23-2	Mark VF750C (1994-1997)	23-33
Air Suction Valve	23-3	Mark VF750C (1998-2003)	23-34
Alternator	23-4	Mark VF750CD (1996-1997)	23-35
Battery	23-5	Mark VF750C2 (1998-2000)	23-36
Bikini Cowl	23-6	Muffler	23-37
Cam Chain	23-7	Oil Pump	23-38
Camshaft	23-8	Pedal	23-39
Carburetor Assembly	23-10	Pulse Generator	23-40
Carburetor Components	23-12	Radiator	23-41
Carburetor Side Cover	23-13	Rear Brake Panel	23-42
Caution Label	23-14	Rear Cylinder Head	23-43
Clutch	23-15	Rear Fender	23-44
Crankcase	23-16	Rear Shock Absorber	23-45
Crankshaft	23-17	Rear Wheel	23-46
Cylinder Head Cover	23-18	Right Crankcase Cover	23-47
Evaporation Canister	23-19	Seat	23-48
Frame	23-20	Side Cover	23-49
Front Brake Caliper	23-21	Speedometer Tachometer	23-50
Front Brake Master Cylinder	23-22	Stand	23-52
Front Cylinder Head	23-23	Starting Motor	23-53
Front Fender	23-24	Steering Stem	23-54
Front Fork	23-25	Step	23-55
Front Wheel	23-26	Swingarm @ Drive Chain	23-56
Fuel Tank	23-27	Taillight	23-57
Gasket Kit A	23-28	Tools	23-58
Gasket Kit B	23-28	Transmission	23-59
Gearshift Drum	23-29	Turn Signal	23-60
Handle Switch Cables	23-30	Water Pipe	23-61
Handlebar	23-31	Water Pump	23-62
Headlight	23-32	Wire Harness	23-63

Air Cleaner

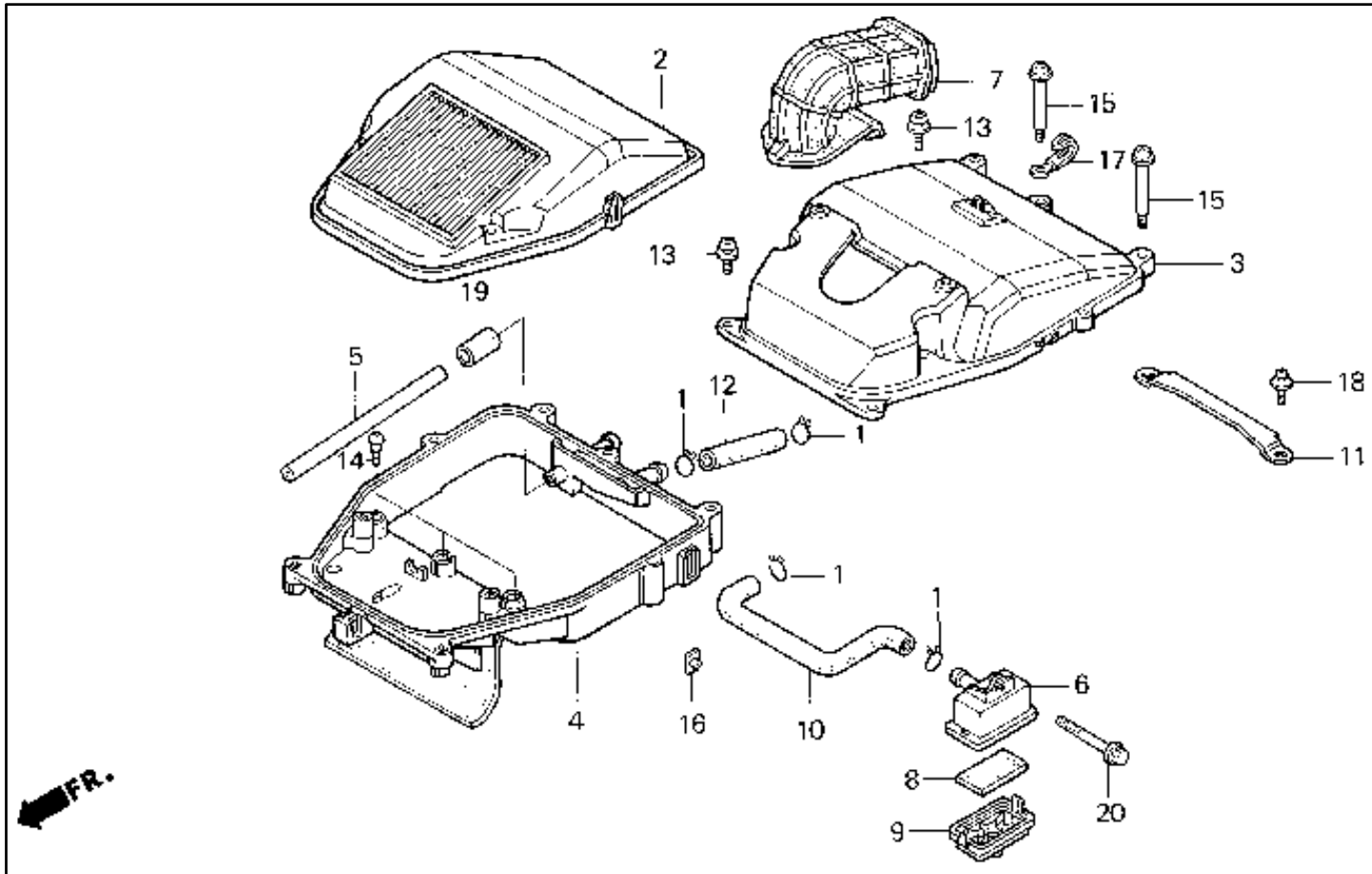

#	Description	Q'ty	Price
01	CLIP, DRAIN TUBE 15772-GB5-670	004	\$2.45
02	AIR CLEANER 17210-MZ5-000	001	\$47.21
03	COVER, A/CLNR HSG 17220-MZ5-000	001	\$67.73
04	AIR CLEANER HOUSING 17230-MZ5-910 (replaces 17230-MZ5-000)	001	\$88.79
04	AIR CLEANER HOUSING 17230-MZ5-740	001	\$84.37
05	PIPE, AIR 17234-MZ5-740	001	\$15.15
06	CASE, SUB A/CLNR 17251-KT8-000	001	\$17.60
07	DUCT 17251-MZ5-000	001	\$44.45
08	FILTER, SUB A/CLNR 17254-KAZ-000	001	\$2.08
09	COVER, SUB A/CLNR 17256-MM4-000	001	\$16.56
10	TUBE, SUB A/CLNR 17258-MZ5-000	001	\$11.07

#	Description	Q'ty	Price
11	STOPPER 17259-MZ5-000	001	\$11.42
12	TUBE A, BREATHER 17355-MZ5-000	001	\$3.22
13	SCREW (5X12) 90105-MB1-000	004	\$2.02
14	SCREW, PAN (5X19) 90141-KT8-000	003	\$3.65
15	SCREW, PAN (4X40) 90141-MZ5-000	005	\$7.11
16	NUT, SPECIAL (6X7) 61304-958-003(replaces 90301-471-000)	002	\$2.64
17	CLIP, SWITCH CORD 91400-MR8-000	001	\$3.27
18	SCREW-WASHER (5X10) 93891-05010-07	002	\$0.43
19	BULK HOSE (12X1000) 95005-12001-10M	001	\$31.53
20	BOLT, FLANGE (6X45) 95701-06045-07 (replaces 95701-06045-00)	001	\$0.97
NI	TIE, CABLE 32901-VB5-800	001	\$2.10

Air Suction Valve

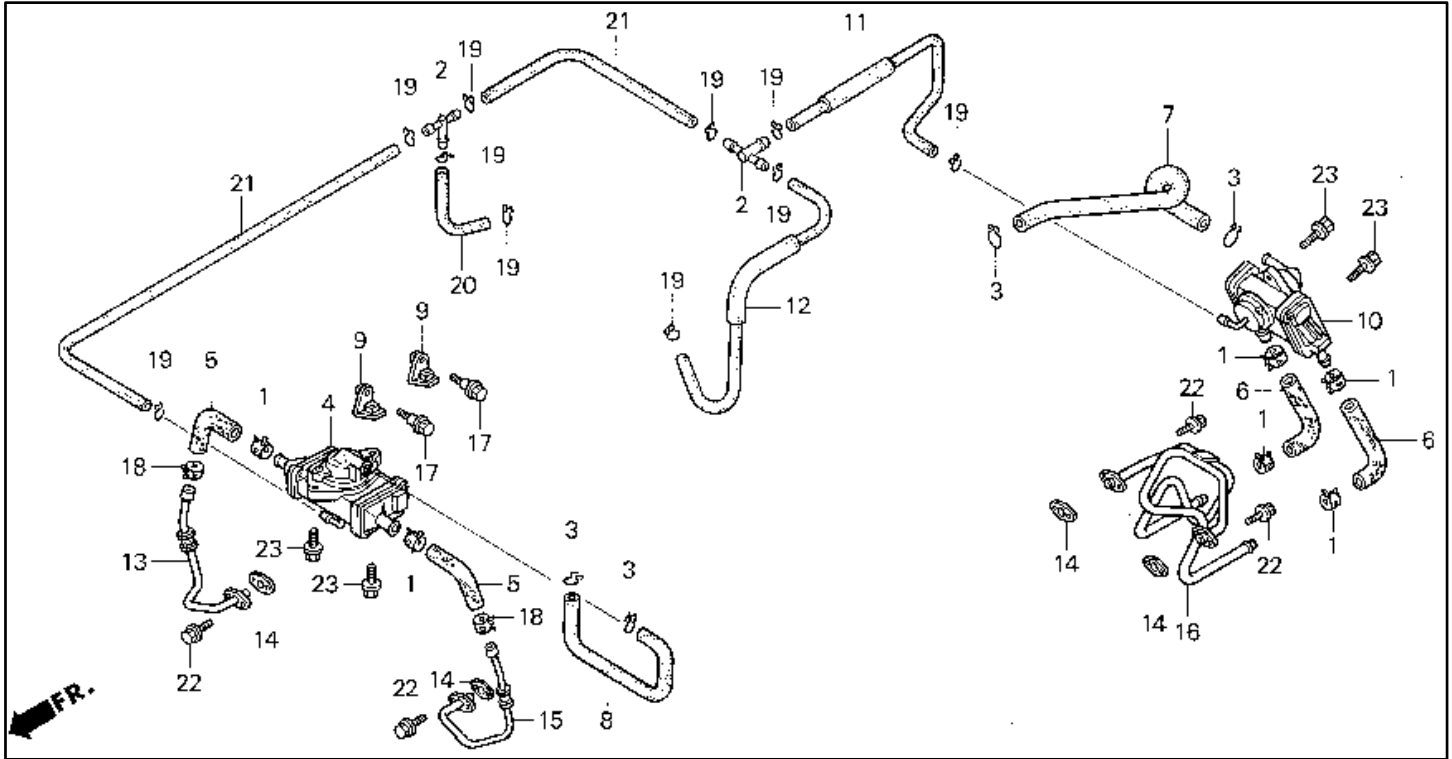

#	Description	Q'ty	Price
01	CLIP B, FUEL HOSE 16968-MC7-000	006	\$4.67
02	JOINT, VACUUM TUBE 17201-MG9-000	002	\$12.51
03	CLIP, BREATHER TUBE 17369-KB4-670	004	\$2.78
04	CONTROL VALVE, FR. 18600-MZ5-740	001	\$129.72
05	HOSE A 18612-MZ5-740	002	\$19.67
06	HOSE A, RR. AIR 18613-MZ5-740	002	\$18.62
07	HOSE C, RR. AIR 18615-MZ5-740	001	\$20.69
08	TUBE, FR. 18616-MZ5-740	001	\$17.16
09	STAY, FR. 18617-MZ5-740	002	\$12.13
10	CONTROL VALVE, RR. 18620-MZ5-740	001	\$153.78
11	TUBE 18625-MZ5-740	001	\$31.86
12	TUBE 18626-MZ5-740	001	\$10.66

#	Description	Q'ty	Price
13	PIPE, R. FR. AIR 18640-MZ5-740	001	\$47.54
14	GSKT, AIR FEED PIPE 18645-MT4-730	004	\$1.96
15	PIPE, L. FR. AIR 18645-MZ5-740	001	\$47.54
16	PIPE, RR. AIR 18650-MZ5-740	001	\$99.53
17	BOLT 90007-PY3-000	002	\$2.88
18	CLAMP, TUBE (D17) 91405-MF5-860	002	\$2.51
19	CLIP, TUBE (B7) 95002-02070	010	\$0.82
20	BULK HOSE (3.5X1000) 95005-35001-20M	001	\$5.42
21	BULK HOSE (3.5X1000) 95005-35001-20M	002	\$5.42
22	*95701-06016-08 95701-06016-00	008	\$0.73
23	BOLT, FLANGE (6X20) 95701-06020-00	004	\$0.60

Alternator

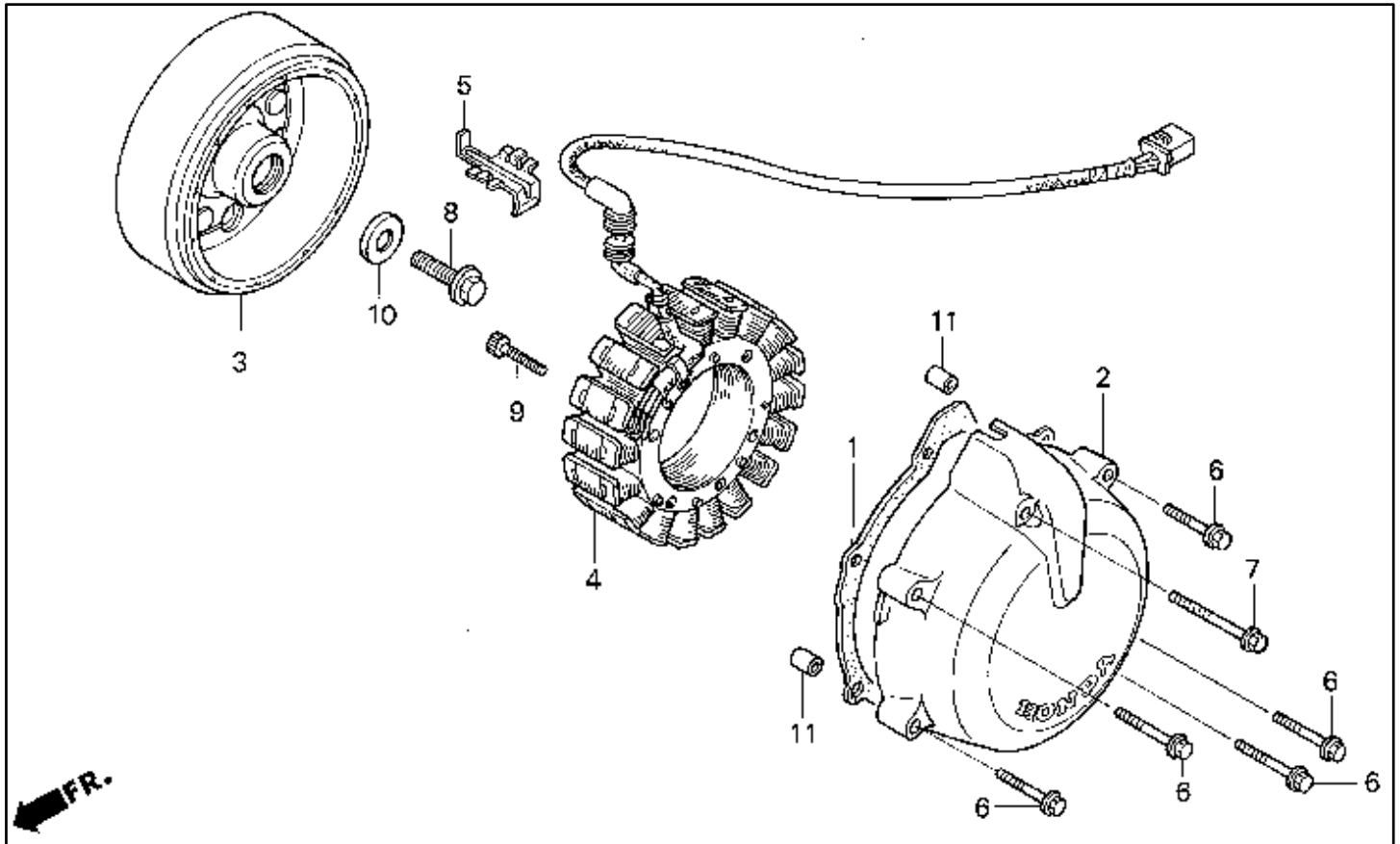

#	Description	Q'ty	Price
01	GASKET 11636-MY7-000	001	\$12.98
02	COVER, ALTERNATOR 11641-MZ5-920 (replaces 11641-MZ5-000)	001	\$329.16
03	FLYWHEEL 31110-MZ5-004	001	\$386.83
04	STATOR 31120-MZ5-004	001	\$332.99
05	CLAMP, CABLE 32111-MZ5-000	001	\$6.36
06	BOLT, FLANGE (6X32) 90001-GHB-690	005	\$2.96

#	Description	Q'ty	Price
07	BOLT, FLANGE (6X60) 90001-GHB-750	001	\$3.93
08	BOLT, FLANGE (10X35) 90003-MN4-000	001	\$4.76
09	BOLT, SOCKET (6X40) 90116-375-000	004	\$3.18
10	WASHER (10X25X4) 90405-ML0-000	001	\$4.76
11	PIN, DOWEL (8X14) 94301-08140	002	\$1.00

Battery

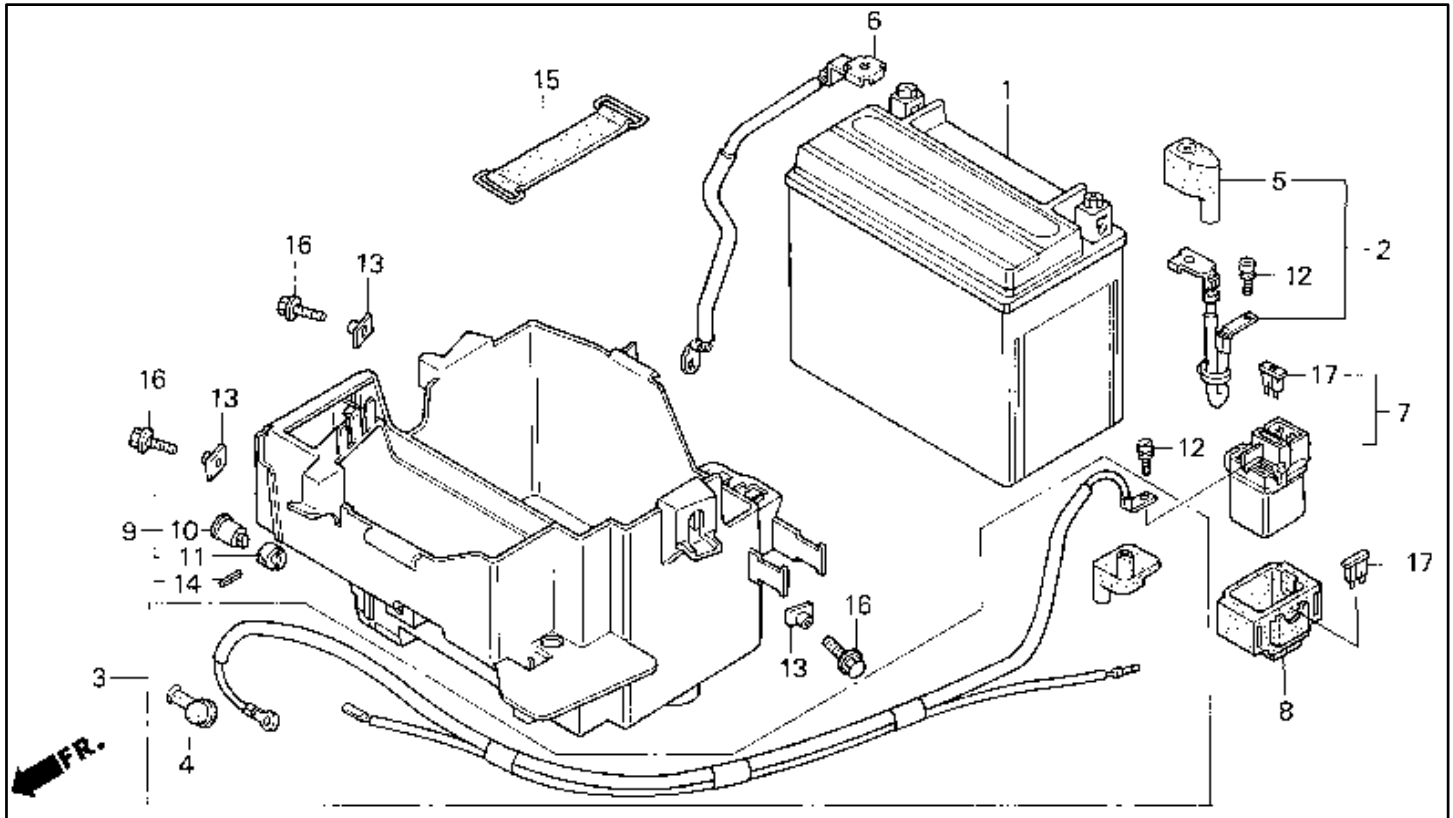

#	Description	Q'ty	Price
01	BATTERY (YTX12-BS) 31500-HF1-678 (replaces 31500-HA0-686, 31500-HF1-677, 31500-KM1-836, 31500- KM1-837)	001	\$69.17
02	CABLE 32401-MZ5-000	001	\$25.07
03	CABLE, STARTER MOTOR 32410-MZ5-000	001	\$51.75
04	COVER 32411-230-000 (replaces 32411-253-000)	001	\$5.60
05	COVER 32414-MZ5-000	001	\$4.04
06	CABLE 32601-MZ5-000	001	\$27.51
07	SWITCH ASSY. 35850-MR5-007	001	\$83.87
08	RUB. SHOCK ABSORBER 35856-MR5-000	001	\$6.95

#	Description	Q'ty	Price
09	BOX ASSY., BATTERY 50330-MZ5-000	001	\$86.89
10	BODY, KEY 83507-422-000	001	\$2.76
11	STOPPER, KEY BODY 83508-KBG-000 (replaces 83508-438-000)	001	\$2.04
12	BOLT, SOCKET (5X9) 90111-MR5-000	002	\$1.87
13	NUT, SPECIAL (6X7) 61304-958-003 (replaces 90301-471-000)	003	\$2.64
14	PIN, SPRING (2X14) 94305-20141	001	\$0.67
15	BAND F, BATTERY 95012-17001	001	\$5.89
16	BOLT, FLANGE (6X12) 96001-06012-00	003	\$0.78
17	FUSE, BLADE (30A) 98200-33000	002	\$0.67

Bikini Cowl

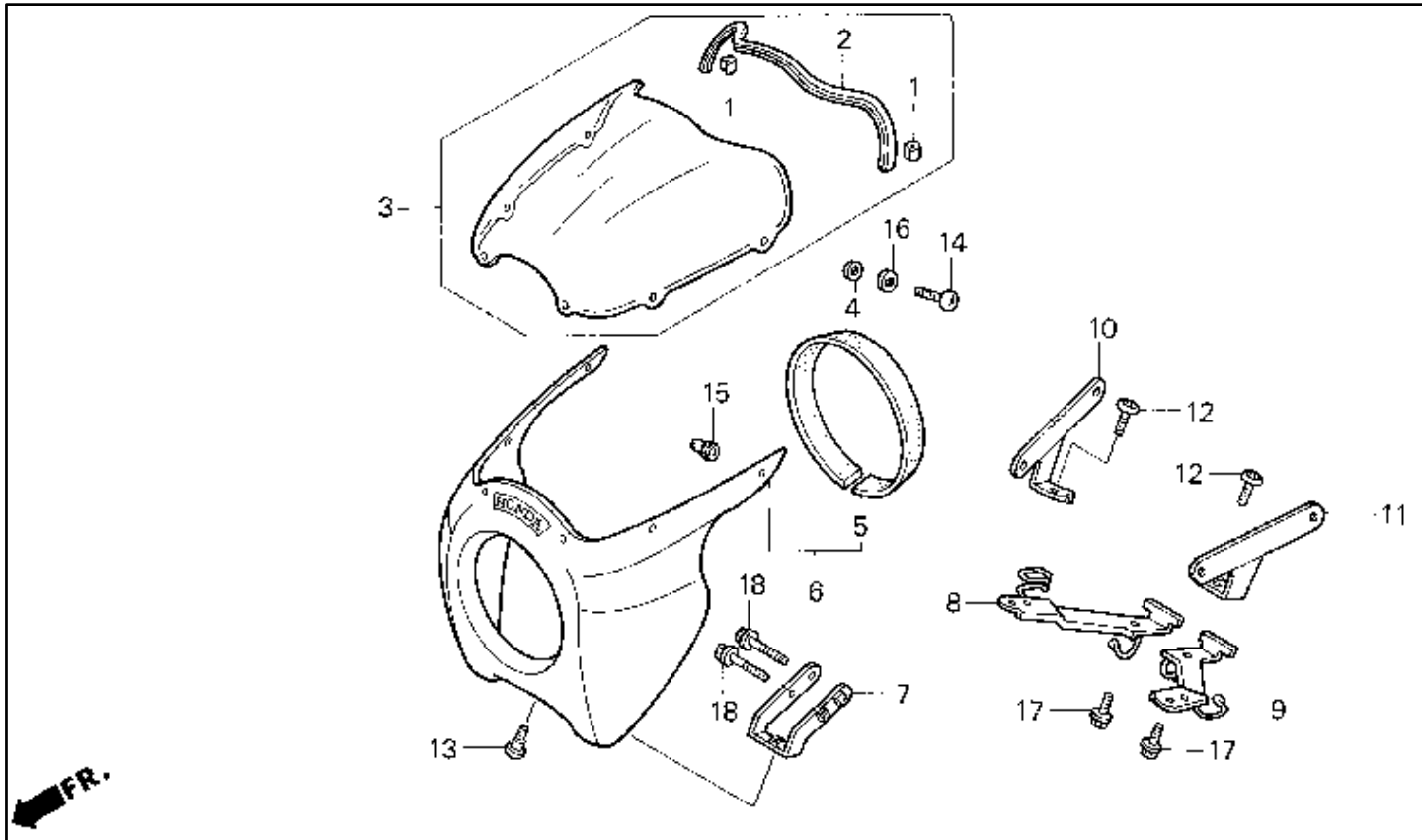

#	Description	Q'ty	Price
01	CLIP, SCREEN MOLDING 64102-MJ0-000	002	\$3.58
02	MOLDING, WINDSCREEN 64105-MZ5-870	001	\$8.60
03	WINDSCREEN 64150-MZ5-870	001	\$218.56
04	WASHER 64205-166-610	006	\$1.62
05	RUBBER, BIKINI COWL 64215-MZ5-870	001	\$35.91
06	COWL SET (TYPE10) 64220-MZ5-870ZA	001	\$579.87
06	COWL SET (TYPE9) 64220-MZ5-870ZB	001	\$579.87
07	STAY, COWL 64505-MZ5-870	001	\$19.36
08	STAY A, R. COWL 64506-MZ5-870	001	\$33.87
09	STAY A, L. COWL 64507-MZ5-870	001	\$33.87

#	Description	Q'ty	Price
10	STAY B, R. COWL 64508-MZ5-870	001	\$17.18
11	STAY B, L. COWL 64509-MZ5-870	001	\$17.18
12	BOLT, SPECIAL (6X17) 90085-MZ1-000	002	\$2.84
13	SCREW, PAN (6X14) 90106-KBV-000	001	\$3.09
14	SCREW, TRUSS (5X20) 90109-MT3-000	006	\$2.00
15	NUT (5MM) 90111-KW3-003	006	\$3.55
16	WASHER (5MM) 90501-MY2-700	006	\$1.60
17	BOLT, FLANGE (8X16) 95701-08016-08	002	\$0.85
18	BOLT, FLANGE (6X50) 96300-06050-07	002	\$1.30

Cam Chain

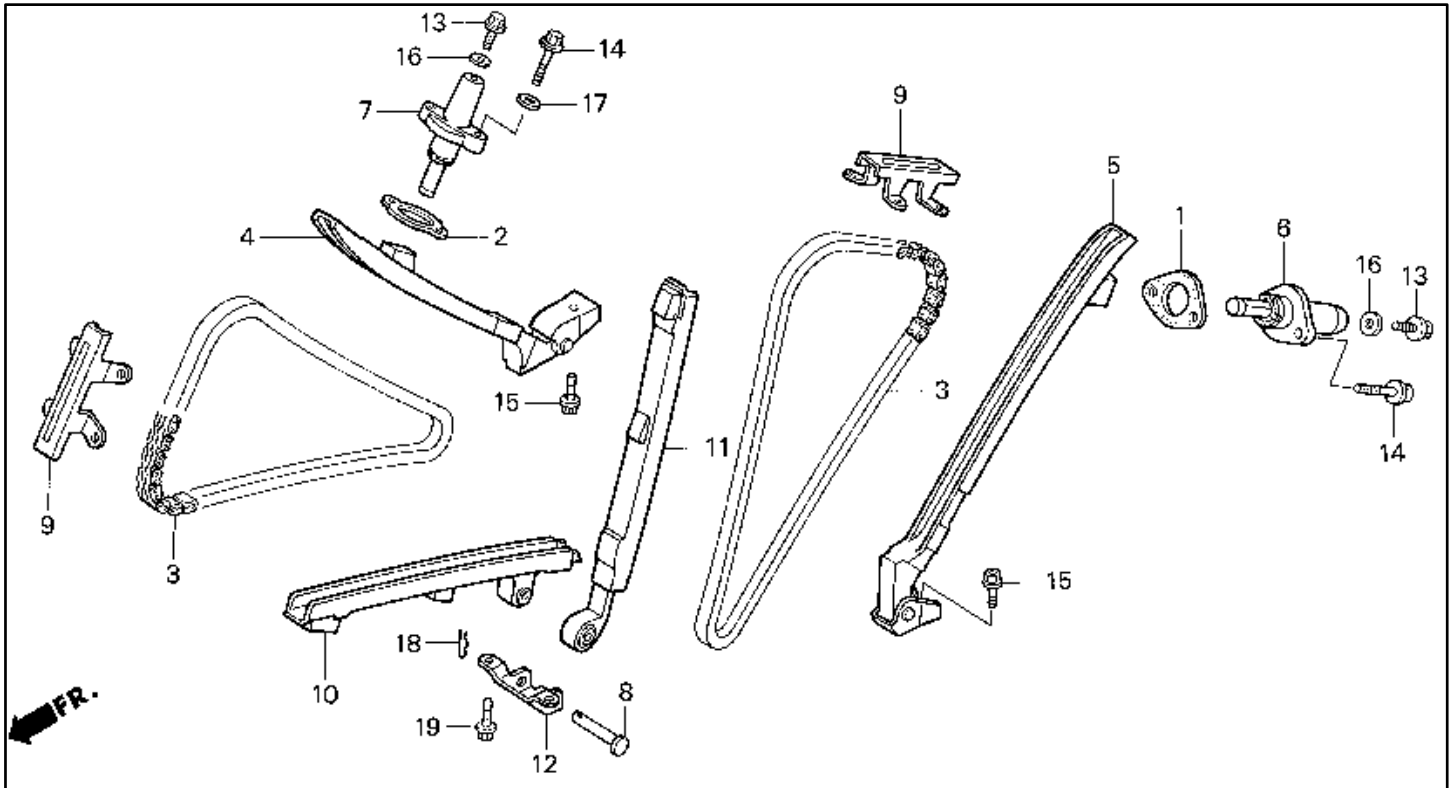

#	Description	Q'ty	Price
01	GSKT, TENSIONER HOLE 12194-HC5-740	001	\$1.78
02	GSKT, TENSIONER HOLE 12194-KW3-880	001	\$1.67
03	CHAIN, CAM 14401-MZ5-921 (replaces 14401-MZ5-003)	002	\$89.02
04	TENSIONER, FR. 14510-MZ5-770 (replaces 14510-MZ5-000)	001	\$108.09
05	TENSIONER, RR. 14515-MZ5-770 (replaces 14515-MZ5-000)	001	\$108.09
06	LIFTER ASSY., RR. 14520-MZ5-003	001	\$75.99
07	LIFTER ASSY., FR. 14530-MZ5-003	001	\$75.99
08	PIN, TENSIONER 14531-MZ5-000	001	\$7.04
09	GUIDE B, CAM CHAIN 14546-MZ5-000	002	\$28.15
10	GUIDE, FR. CAM CHAIN 14620-MZ5-000	001	\$50.43

#	Description	Q'ty	Price
11	GUIDE, RR. CAM CHAIN 14625-MZ5-000	001	\$51.58
12	STAY 14627-MZ5-000	001	\$23.11
13	BOLT, FLANGE (6X10) 90004-GHB-600 (replaces 90001-GHB-600)	002	\$2.47
14	BOLT, FLANGE (6X25) 90004-GHB-670 (replaces 90001-GHB-670)	004	\$2.22
15	BOLT (6X14) 90009-MZ8-H00 (replaces 90009-ME5-000)	002	\$1.15
16	WASHER (6MM) 90442-397-000	002	\$1.33
16	WASHER (6MM) 90502-KBV-000	002	\$0.93
17	WASHER (6.5MM) 90463-ML7-000	002	\$2.25
18	PIN (6MM) 90607-ME5-000	001	\$1.95
19	BOLT, FLANGE (6X14) 95701-06014-00	002	\$0.63

Camshaft

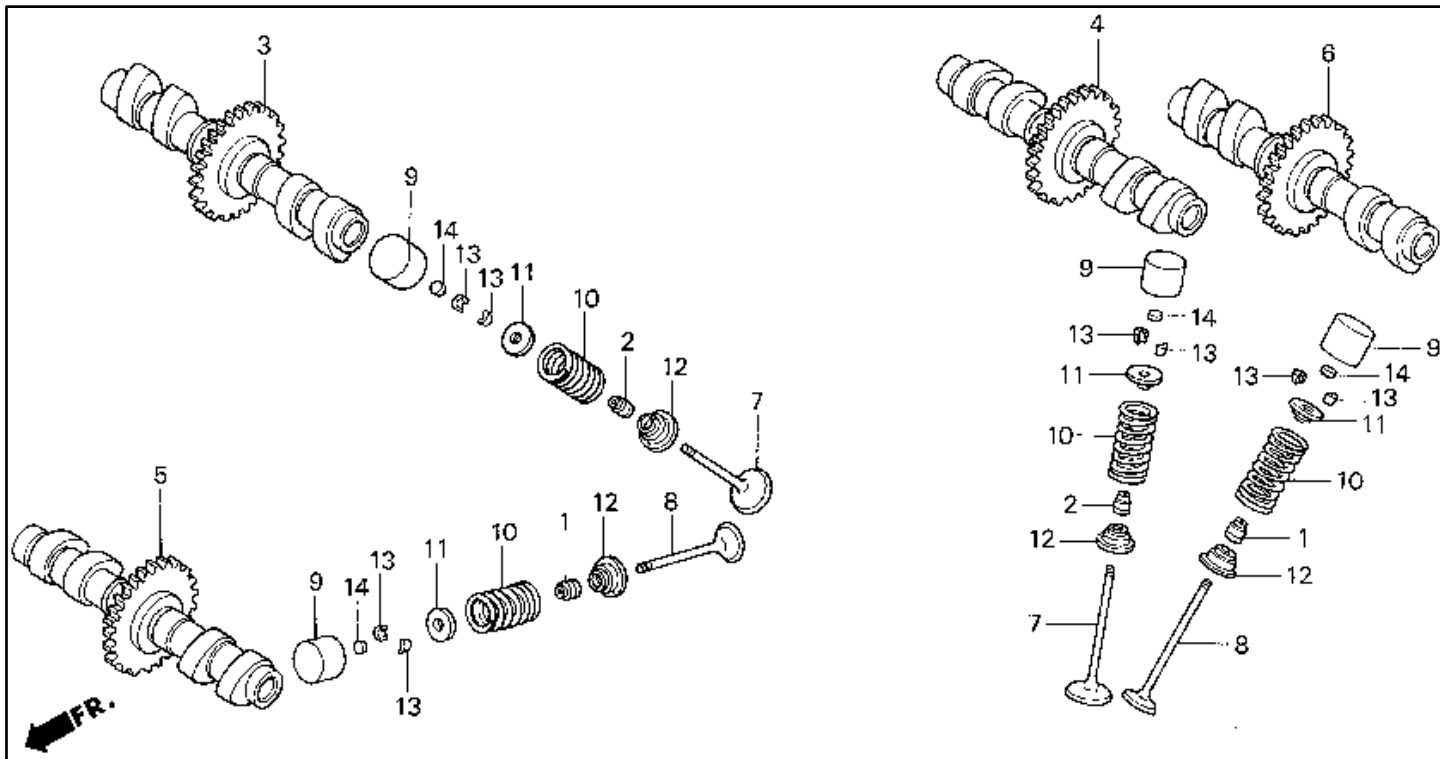

#	Description	Q'ty	Price
01	SEAL, EX. VALVE STEM 12208-ML0-721	008	\$8.07
02	SEAL, VALVE STEM 12209-MZ5-003	008	\$7.69
03	CAMSHAFT, FR. IN. 14110-MZ5-000	001	\$261.83
04	CAMSHAFT, RR. IN. 14120-MZ5-000	001	\$278.02
05	CAMSHAFT, FR. EX. 14130-MZ5-000	001	\$258.56
06	CAMSHAFT, RR. EX. 14140-MZ5-000	001	\$261.83
07	VALVE, IN. 14711-MT4-000	008	\$25.73
08	VALVE, EX. 14721-MY3-000	008	\$45.22
09	LIFTER, VALVE 14731-MT4-010 (replaces 14731-MT4-000)	016	\$33.35
10	SPRING, VALVE 14751-MZ5-003	016	\$7.96
11	RETAINER, VLV SPR 14771-KW3-900	016	\$8.36
12	SEAT, VALVE SPRING 14775-PM3-000	016	\$3.38
13	COTTER, VALVE 14781-ML0-720	032	\$2.71
14	SHIM, TAPPET (1.200) 14901-KT7-013	016	\$6.78
14	SHIM, TAPPET (1.225) 14902-KT7-013	016	\$6.78
14	SHIM, TAPPET (1.250) 14903-KT7-013	016	\$6.78
14	SHIM, TAPPET (1.275) 14904-KT7-013	016	\$6.78
14	SHIM, TAPPET (1.300) 14905-KT7-013	016	\$6.78
14	SHIM, TAPPET (1.325) 14906-KT7-013	016	\$6.78
14	SHIM, TAPPET (1.350) 14907-KT7-013	016	\$6.78

#	Description	Q'ty	Price
14	SHIM, TAPPET (1.375) 14908-KT7-013	016	\$6.78
14	SHIM, TAPPET (1.400) 14909-KT7-013	016	\$6.78
14	SHIM, TAPPET (1.425) 14910-KT7-013	016	\$6.78
14	SHIM, TAPPET (1.450) 14911-KT7-013	016	\$6.78
14	SHIM, TAPPET (1.475) 14912-KT7-013	016	\$6.78
14	SHIM, TAPPET (1.500) 14913-KT7-013	016	\$6.78
14	SHIM, TAPPET (1.525) 14914-KT7-013	016	\$6.78
14	SHIM, TAPPET (1.550) 14915-KT7-013	016	\$6.78
14	SHIM, TAPPET (1.575) 14916-KT7-013	016	\$6.78
14	SHIM, TAPPET (1.600) 14917-KT7-013	016	\$6.78
14	SHIM, TAPPET (1.625) 14918-KT7-013	016	\$6.78
14	SHIM, TAPPET (1.650) 14919-KT7-013	016	\$6.78
14	SHIM, TAPPET (1.675) 14920-KT7-013	016	\$6.78
14	SHIM, TAPPET (1.700) 14921-KT7-013	016	\$6.78
14	SHIM, TAPPET (1.725) 14922-KT7-013	016	\$6.78
14	SHIM, TAPPET (1.750) 14923-KT7-013	016	\$6.78
14	SHIM, TAPPET (1.775) 14924-KT7-013	016	\$6.78
14	SHIM, TAPPET (1.800) 14925-KT7-013	016	\$6.78
14	SHIM, TAPPET (1.825) 14926-KT7-013	016	\$6.78
14	SHIM, TAPPET (1.850) 14927-KT7-013	016	\$6.78

Appendix A: Part Numbers

#	Description	Q'ty	Price
14	SHIM, TAPPET (1.875) 14928-KT7-013	016	\$6.78
14	SHIM, TAPPET (1.900) 14929-KT7-013	016	\$6.78
14	SHIM, TAPPET (1.925) 14930-KT7-013	016	\$6.78
14	SHIM, TAPPET (1.950) 14931-KT7-013	016	\$6.78
14	SHIM, TAPPET (1.975) 14932-KT7-013	016	\$6.78
14	SHIM, TAPPET (2.000) 14933-KT7-013	016	\$6.78
14	SHIM, TAPPET (2.025) 14934-KT7-013	016	\$6.78
14	SHIM, TAPPET (2.050) 14935-KT7-013	016	\$6.78
14	SHIM, TAPPET (2.075) 14936-KT7-013	016	\$6.78
14	SHIM, TAPPET (2.100) 14937-KT7-013	016	\$6.78
14	SHIM, TAPPET (2.125) 14938-KT7-013	016	\$6.78
14	SHIM, TAPPET (2.150) 14939-KT7-013	016	\$6.78
14	SHIM, TAPPET (2.175) 14940-KT7-013	016	\$6.78
14	SHIM, TAPPET (2.200) 14941-KT7-013	016	\$6.78
14	SHIM, TAPPET (2.225) 14942-KT7-013	016	\$6.78
14	SHIM, TAPPET (2.250) 14943-KT7-013	016	\$6.78
14	SHIM, TAPPET (2.275) 14944-KT7-013	016	\$6.78
14	SHIM, TAPPET (2.300) 14945-KT7-013	016	\$6.78
14	SHIM, TAPPET (2.325) 14946-KT7-013	016	\$6.78
14	SHIM, TAPPET (2.350) 14947-KT7-013	016	\$6.78
14	SHIM, TAPPET (2.375) 14948-KT7-013	016	\$6.78
14	SHIM, TAPPET (2.400) 14949-KT7-013	016	\$6.78

#	Description	Q'ty	Price
14	SHIM, TAPPET (2.425) 14950-KT7-013	016	\$6.78
14	SHIM, TAPPET (2.450) 14951-KT7-013	016	\$6.78
14	SHIM, TAPPET (2.475) 14952-KT7-013	016	\$6.78
14	SHIM, TAPPET (2.500) 14953-KT7-013	016	\$6.78
14	SHIM, TAPPET (2.525) 14954-KT7-013	016	\$6.78
14	SHIM, TAPPET (2.550) 14955-KT7-013	016	\$6.78
14	SHIM, TAPPET (2.575) 14956-KT7-013	016	\$6.78
14	SHIM, TAPPET (2.600) 14957-KT7-013	016	\$6.78
14	SHIM, TAPPET (2.625) 14958-KT7-013	016	\$6.78
14	SHIM, TAPPET (2.650) 14959-KT7-013	016	\$6.78
14	SHIM, TAPPET (2.675) 14960-KT7-013	016	\$6.78
14	SHIM, TAPPET (2.700) 14961-KT7-013	016	\$6.78
14	SHIM, TAPPET (2.725) 14962-KT7-013	016	\$6.78
14	SHIM, TAPPET (2.750) 14963-KT7-013	016	\$6.78
14	SHIM, TAPPET (2.775) 14964-KT7-013	016	\$6.78
14	SHIM, TAPPET (2.800) 14965-KT7-013	016	\$6.78
14	SHIM, TAPPET (2.825) 14966-KT7-013	016	\$6.78
14	SHIM, TAPPET (2.850) 14967-KT7-013	016	\$6.78
14	SHIM, TAPPET (2.875) 14968-KT7-013	016	\$6.78
14	SHIM, TAPPET (2.900) 14969-KT7-013	016	\$6.78

Carburetor Assembly

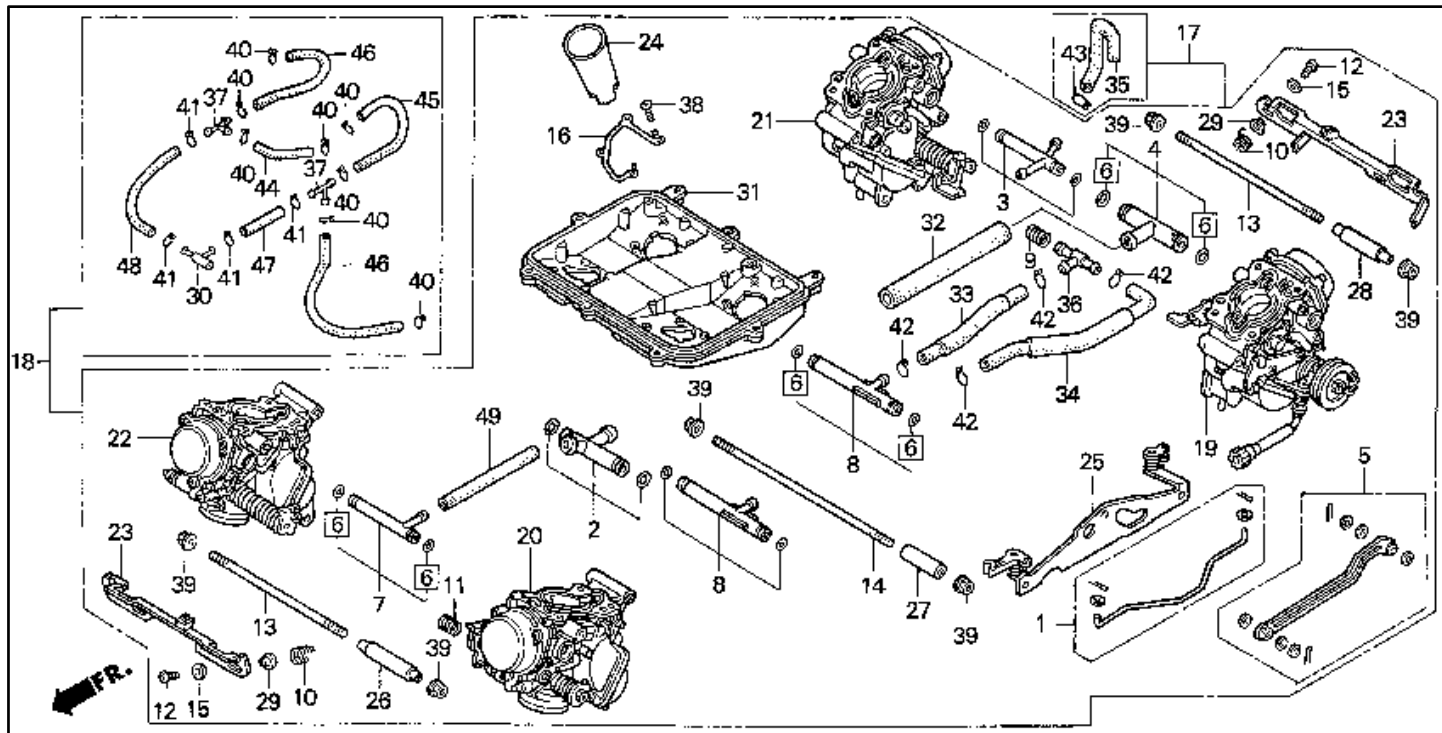

#	Description	Q'ty	Price
01	ROD SET, LINK 16018-MZ5-600	001	\$45.42
02	JOINT SET 16026-MZ5-600	001	\$31.65
03	JOINT SET, FUEL 16027-MB6-671	001	\$28.47
04	JOINT SET 16027-MZ5-600	001	\$31.65
05	LEVER SET, LINK 16035-MZ5-600	001	\$31.51
06	GASKET B SET 16040-MZ5-600	002	\$13.73
07	JOINT SET, FUEL 16047-KE7-003	001	\$32.87
08	JOINT SET 16047-MZ5-600	002	\$30.27
09	SPRING 16050-MZ5-600	001	\$9.69
10	SPRING 16051-MZ5-670	002	\$7.91
11	SPRING 16053-MB0-671	001	\$7.09
12	SCREW-WASHER 16081-KAZ-000	004	\$2.22
13	BOLT 16083-MZ5-670	002	\$23.65
14	BOLT 16084-MZ5-670	001	\$23.65
15	WASHER, PLAIN 16085-MV4-000	004	\$1.95
16	WASHER 16090-MZ5-600	004	\$2.95
17	CARBURETOR ASSY. 16100-MZ5-670	001	\$1,644.16
18	CARBURETOR ASSY. 16100-MZ5-740	001	\$1,644.16
19	CARBURETOR ASSY. 1 16101-MZ5-670	001	\$480.69
19	CARBURETOR ASSY. 1 16101-MZ5-740	001	\$480.69
20	CARBURETOR ASSY. 2 16102-MZ5-670	001	\$480.69
20	CARBURETOR ASSY. 2 16102-MZ5-740	001	\$480.69
21	CARBURETOR ASSY. 3 16103-MZ5-670	001	\$480.69
21	CARBURETOR ASSY. 3 16103-MZ5-740	001	\$480.69
22	CARBURETOR ASSY. 4 16104-MZ5-670	001	\$480.69
22	CARBURETOR ASSY. 4 16104-MZ5-740	001	\$480.69
23	LEVER, STARTER 16121-MZ5-600	002	\$30.40
24	FUNNEL, AIR 16141-MZ5-600	004	\$20.85

#	Description	Q'ty	Price
25	STAY, JOINT 16169-MZ5-670	001	\$21.11
26	COLLAR 16172-MZ5-670	001	\$19.36
27	COLLAR 16173-MZ5-670	001	\$15.85
28	COLLAR 16174-MZ5-670	001	\$19.36
29	COLLAR 16175-MZ1-000	004	\$9.40
30	T-JOINT 16179-MB2-881	001	\$22.62
31	BASE, AIR CLEANER 16188-MZ5-600	001	\$149.59
32	TUBE (15X170) 16195-MZ5-670	001	\$4.64
33	TUBE, FUEL 16197-MZ5-670	001	\$12.65
34	TUBE, FUEL 16198-MZ5-671	001	\$15.31
35	TUBE 16199-MZ5-670	001	\$3.62
36	T-JOINT 17193-MN5-000	001	\$13.60
37	T-JOINT 17194-MN5-000	002	\$8.89
38	SCREW, PAN (4X16) 93500-04016-0G	016	\$0.47
39	NUT, FLANGE (6MM) 94050-06000	006	\$0.72
40	CLIP, TUBE (B18) 95002-02089	008	\$0.76
41	CLIP, TUBE (B10) 95002-02109	004	\$1.02
42	CLIP, TUBE (B12) 95002-02129	004	\$1.02
43	CLIP, TUBE (B12.5) 95002-02139	001	\$1.02
44	BULK HOSE (4.5X1000) 95005-45001-20M	001	\$19.42
45	BULK HOSE (4.5X1000) 95005-45001-20M	001	\$19.42
46	BULK HOSE (4.5X1000) 95005-45001-20M	002	\$19.42
47	BULK HOSE (5.5X3000) 95005-55003-20M	001	\$18.33
48	BULK HOSE (5.5X3000) 95005-55003-20M	001	\$18.33
49	BULK HOSE (7X1000) 95005-70001-50M	001	\$7.63

Carburetor Components

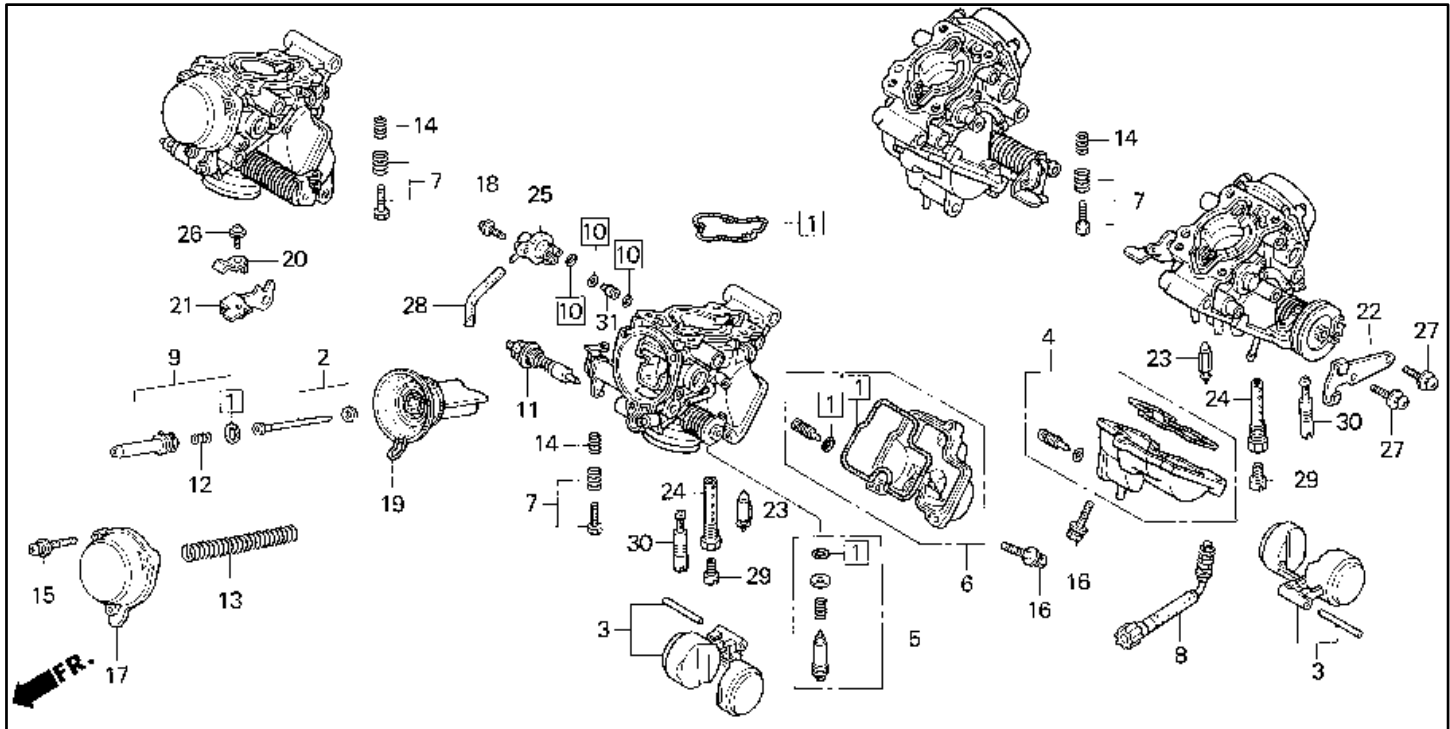

#	Description	Q'ty	Price
01	GASKET SET A 16010-MZ5-600	004	\$32.85
02	NEEDLE SET, JET 16012-MZ5-600	004	\$34.20
02	NEEDLE SET, JET 16012-MZ5-670	004	\$33.85
03	FLOAT SET 16013-MY1-000	004	\$36.55
04	CHAMBER SET, FLOAT 16015-MV9-670	002	\$100.65
05	SCREW SET 16016-MAS-670 (replaces 16016-MV9-730)	004	\$17.36
06	CHAMBER SET, FLOAT 16023-MV9-670	002	\$127.01
07	SCREW SET 16028-MZ5-600	003	\$32.13
08	SCREW SET 16029-MZ5-600	001	\$24.80
09	PLATE SET, VALVE 16037-MV4-000	004	\$18.07
10	GASKET SET C 16041-MZ5-600	004	\$12.42
11	VALVE SET, STARTER 16046-MV9-670	004	\$47.54
12	SPRING 16051-MV4-000	004	\$13.67
13	SPRING 16051-MZ5-600	004	\$7.91
14	SPRING 16052-MV4-000	003	\$2.95
15	SCREW, PAN 16080-MV4-000	012	\$1.67
16	BOLT-WASHER (5X16) 16082-PH9-005	012	\$2.16
17	TOP 16107-MZ5-671	004	\$38.78

#	Description	Q'ty	Price
18	SCREW 16108-MW0-750	004	\$1.73
19	PISTON, VACUUM 16111-MZ5-600	004	\$119.21
20	PLATE, STAY 16119-MZ2-600	001	\$13.64
21	PLATE, STAY 16119-MZ5-600	001	\$13.96
22	STAY, WIRE 16119-MZ5-670	001	\$17.35
23	VALVE, FLOAT 16155-MN9-004	004	\$23.04
24	HOLDER, NEEDLE JET 16165-MN4-013	004	\$14.63
25	VALVE ASSY., AIR CUT 16510-MZ2-650	004	\$59.62
26	SCREW-WASHER (4X10) 93892-04010-00 (replaces 93892-04010-10)	001	\$0.60
27	SCREW-WASHER (5X10) 93892-05010-00 (replaces 93892-05010-10)	002	\$0.30
28	BULK HOSE (3.5X1000) 95005-35001-20M	004	\$5.42
29	JET, MAIN (#102) 99101-GHB-1020 (replaces 99101-393-1020)	004	\$5.20
29	JET, MAIN (#102) 99101-GHB-1020	004	\$5.20
30	JET, SLOW (#40) 99103-MT2-0400	004	\$8.38
31	JET, SLOW AIR (#110) 99108-MW0-1102 (replaces 99108-MW0-1100)	004	\$4.56
31	JET (#110) 99108-MY1-1100	004	\$8.24

Carburetor Side Cover

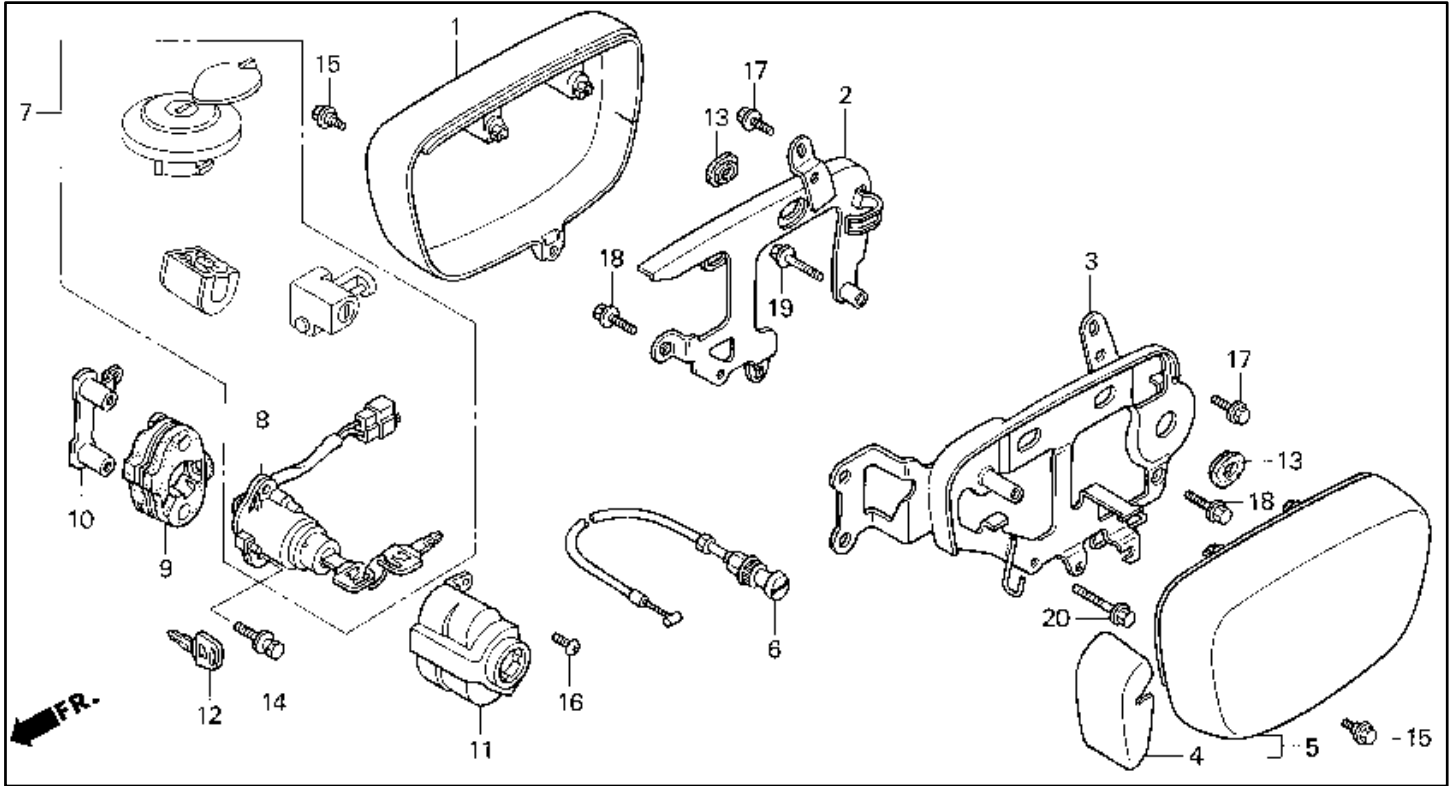

#	Description	Q'ty	Price
01	CVR, CARBURETOR SIDE 17255-MZ5-000	001	\$72.38
02	BASE, R. 17256-MZ5-000	001	\$48.58
03	BASE, L. 17266-MZ5-000	001	\$46.88
04	PROTECTOR 17267-MZ5-300	001	\$12.13
05	COVER SET, L. 17268-MZ5-000	001	\$91.70
06	CABLE, CHOKE 17950-MZ5-000	001	\$23.56
07	LOCK SET 35010-MZ5-000	001	Call For Price
08	SWITCH, COMBINATION 35100-MZ5-A01 (replaces 35100-MZ5-007)	001	\$49.44
09	BASE 35102-MR1-000	001	\$9.75
10	COLLAR 35103-MR1-000	001	\$15.58
11	COVER 35110-MZ5-000	001	\$14.45

#	Description	Q'ty	Price
12	KEY, BLANK (TYPE1) 35121-MR1-770	001	\$7.38
12	KEY, BLANK (TYPE2) 35122-MR1-770	001	\$7.38
13	GROMMET, A/CLNR HSG 83551-GE2-000	004	\$3.18
14	BOLT, BREAK OFF 90107-MR1-000	002	\$6.16
15	BOLT, FLANGE (6MM) 90113-KW3-000	002	\$2.84
16	SCREW, RR. COVER 90114-GB6-920	001	\$1.18
17	BOLT, FLANGE (6X10) 95701-06010-00	002	\$0.75
18	*95701-06016-08 95701-06016-00	002	\$0.73
19	BOLT, FLANGE (6X30) 95701-06030-00	001	\$0.83
20	BOLT, FLANGE (6X35) 95701-06035-00	001	\$0.75

Caution Label

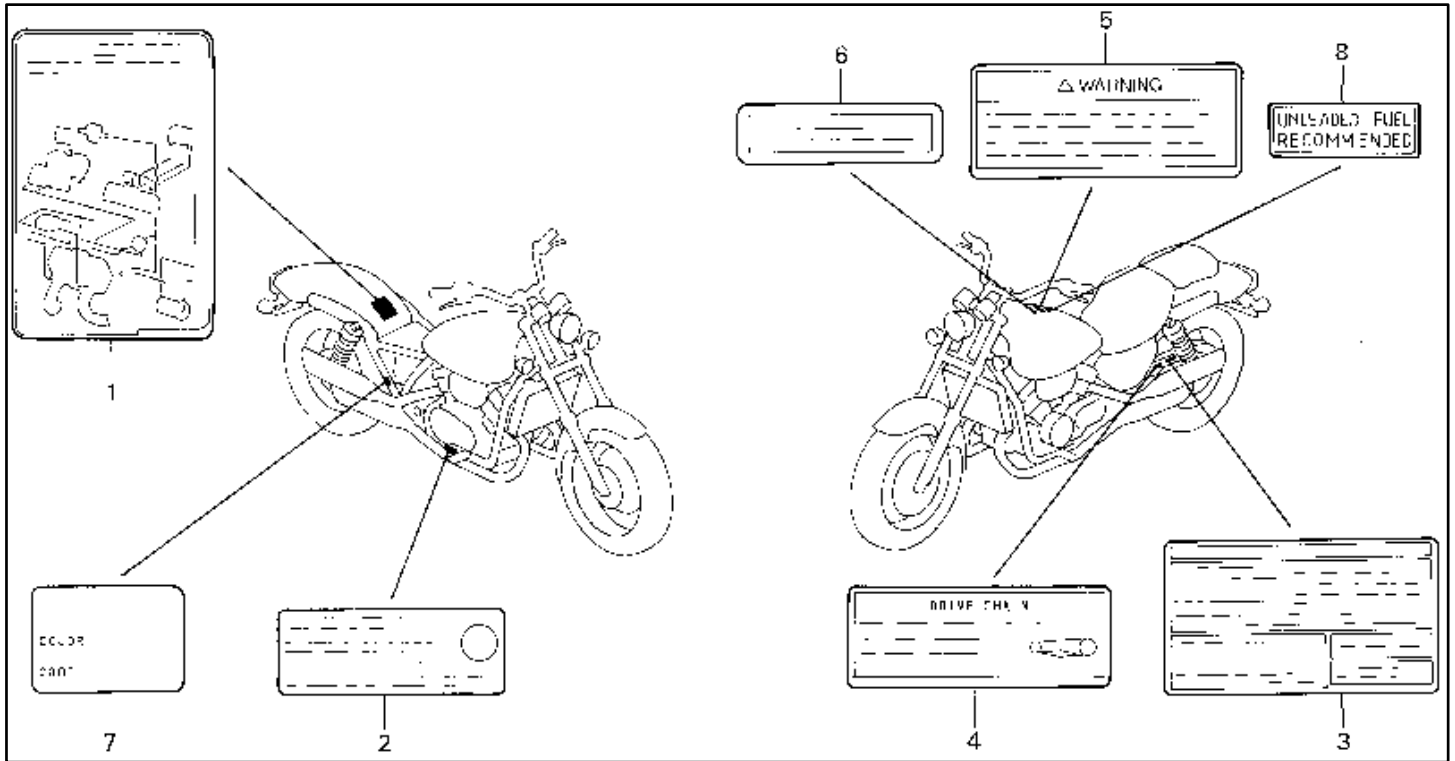

#	Description	Q'ty	Price
01	DIAGRAM 87135-MZ5-740	001	\$3.27
02	LABEL, HIGH ALTITUDE 87139-463-670	001	\$5.02
03	LABEL, TIRE 87505-MZ5-670	001	\$3.78
04	LABEL, DRIVE CHAIN 87507-MZ5-670	001	\$3.78
05	MARK 87512-MZ3-670	001	\$4.51
06	LABEL, DRIVE (TYPE2) 87560-MW0-670ZB	001	\$4.62

#	Description	Q'ty	Price
07	LABEL (R201) (TYPE1) 87565-MZ5-670ZA	001	\$2.16
07	LABEL (NH1) (TYPE2) 87565-MZ5-670ZB	001	\$2.16
07	LABEL (Y124) (TYPE3) 87565-MZ5-670ZC	001	\$2.16
08	LABEL, FUEL (TYPEG) 87586-MR6-670ZA	001	\$2.33
08	LABEL, FUEL (TYPEB) 87586-MR6-670ZF	001	\$2.22

Clutch

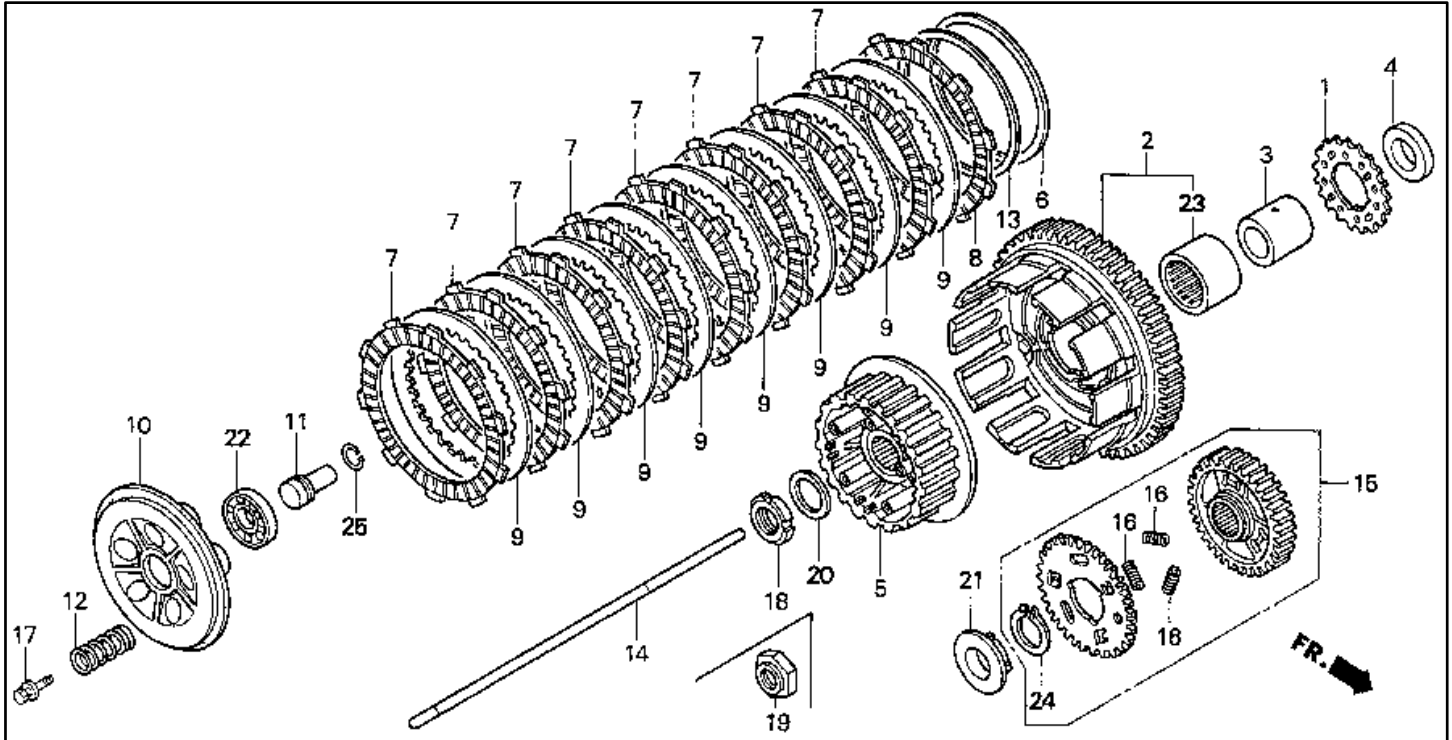

#	Description	Q'ty	Price
01	SPROCKET 15131-ML7-000	001	\$28.64
02	CLUTCH (OUTER) 22100-MZ5-010 (replaces 22100-MZ5-000)	001	\$349.77
03	GUIDE, CLUTCH 22116-MB0-000	001	\$22.93
04	COLR, CLUTCH (OUTER) 22117-ML7-690	001	\$8.11
05	CENTER, CLUTCH 22120-ML7-010 (replaces 22120-ML7-000)	001	\$96.21
06	SEAT, JUDDER SPRING 22125-ML7-000	001	\$8.11
07	DISK, CL FRICTION 22201-MS6-620 (replaces 22201-KG0-980, 22201-KM4-000)	008	\$11.24
08	DISK B, CL FRICTION 22202-ML4-611	001	\$12.51
09	PLATE, CLUTCH 22321-MR7-000 (replaces 22321-ML7-000)	008	\$10.64
10	PLATE, CLU PRESS 22350-ML7-000	001	\$52.03
11	PIECE, CLUTCH JOINT 22366-KE8-000	001	\$8.73
12	SPRING, CLUTCH 22401-KZ3-000 (replaces 22401-ML7-000)	005	\$3.51
13	SPRING, JUDDER 22402-ML7-000	001	\$17.18

#	Description	Q'ty	Price
14	ROD, CLUTCH LIFTER 22850-MZ5-000	001	\$24.56
15	GEAR, PRIMARY DRIVE 23110-ML7-010	001	\$167.74
16	SPRING 23115-MG8-300	003	\$2.33
17	BOLT-WASHER (6X25) 90022-MM5-000	005	\$2.33
18	NUT, LOCK (22MM) 90231-MK7-670	001	\$7.93
19	NUT, LOCK (22MM) 90231-MZ7-000	001	\$8.22
20	WASHER (22MM) 90432-MB0-010	001	\$6.58
21	GUIDE 90509-MR7-000	001	\$35.22
22	BEARING (16003) 91011-KK6-013 (replaces 91008-362-000, 91008-KK6-000, 91010-HC0-003)	001	\$12.09
23	BEARING (35X42X30) 91024-MB0-003	001	\$56.71
24	CIRCLIP (32MM) 94510-32000	001	\$0.97
25	CLIP (15MM) 94601-15000	001	\$0.68

Crankcase

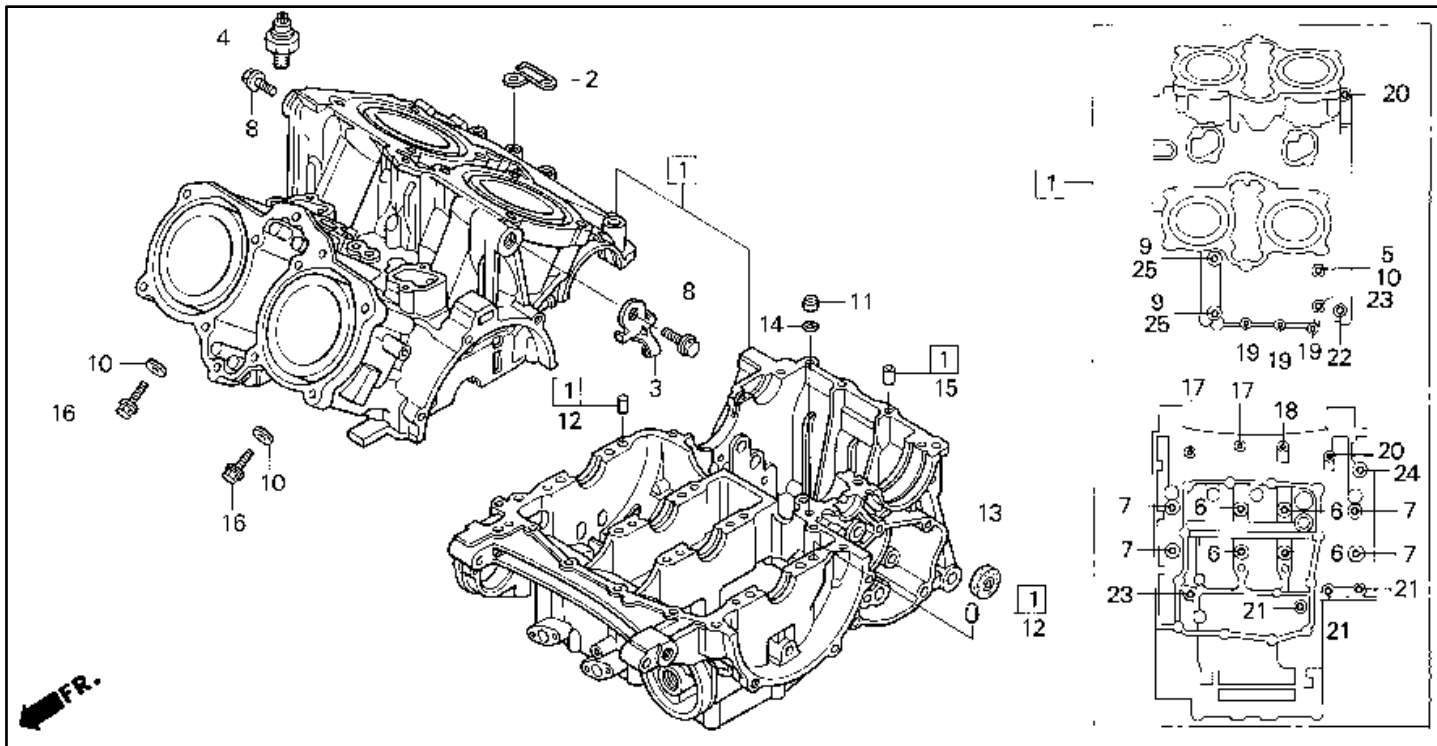

#	Description	Q'ty	Price
01	CRANKCASE SET 11000-MZ5-000	001	\$2,318.80
02	GUIDE, HOSE 11337-MZ5-000	001	\$7.62
03	RECEIVER 22821-MZ5-000	001	\$22.47
04	SWITCH, OIL PRESSURE 35500-MJ4-024	001	\$32.20
05	BOLT, FLANGE (6X96) 90003-PC9-000	001	\$4.37
06	BOLT, UBS (9X88) 90014-ML7-000	004	\$7.33
07	BOLT, UBS (9X108) 90016-ML7-000	004	\$8.73
08	BOLT, FLANGE (10X20) 90130-126-900	002	\$3.18
09	WASHER (10MM) 90403-MG7-000	002	\$2.62
10	WASHER (6.5MM) 90463-ML7-000	003	\$2.25
11	ORIFICE (1.0) 90701-ML7-000	001	\$5.65
12	PIN, DOWEL (10X16) 90701-MV9-670	002	\$3.38
13	OIL SEAL (8X25X8) 91204-MB0-013	001	\$3.18

#	Description	Q'ty	Price
14	O-RING (7.7X2.3) 91301-PC9-003 (replaces 91308-283-000, 91313-393-003)	001	\$1.45
15	PIN, DOWEL (8X14) 94301-08140	001	\$1.00
16	BOLT, FLANGE (6X12) 95701-06012-00	002	\$0.72
17	BOLT, FLANGE (6X28) 95701-06028-00	002	\$0.85
18	BOLT, FLANGE (6X35) 95701-06035-00	001	\$0.75
19	BOLT, FLANGE (6X40) 95701-06040-00	003	\$0.85
20	BOLT, FLANGE (6X45) 95701-06045-07 (replaces 95701-06045-00)	002	\$0.97
21	BOLT, FLANGE (6X50) 95701-06050-00	003	\$0.98
22	BOLT, FLANGE (6X55) 95701-06055-00	001	\$1.70
23	BOLT, FLANGE (6X65) 95701-06065-00	002	\$1.03
24	BOLT, FLANGE (8X45) 95701-08045-00	001	\$1.02
25	BOLT, FLANGE (10X90) 95701-10090-00	002	\$2.72

Crankshaft

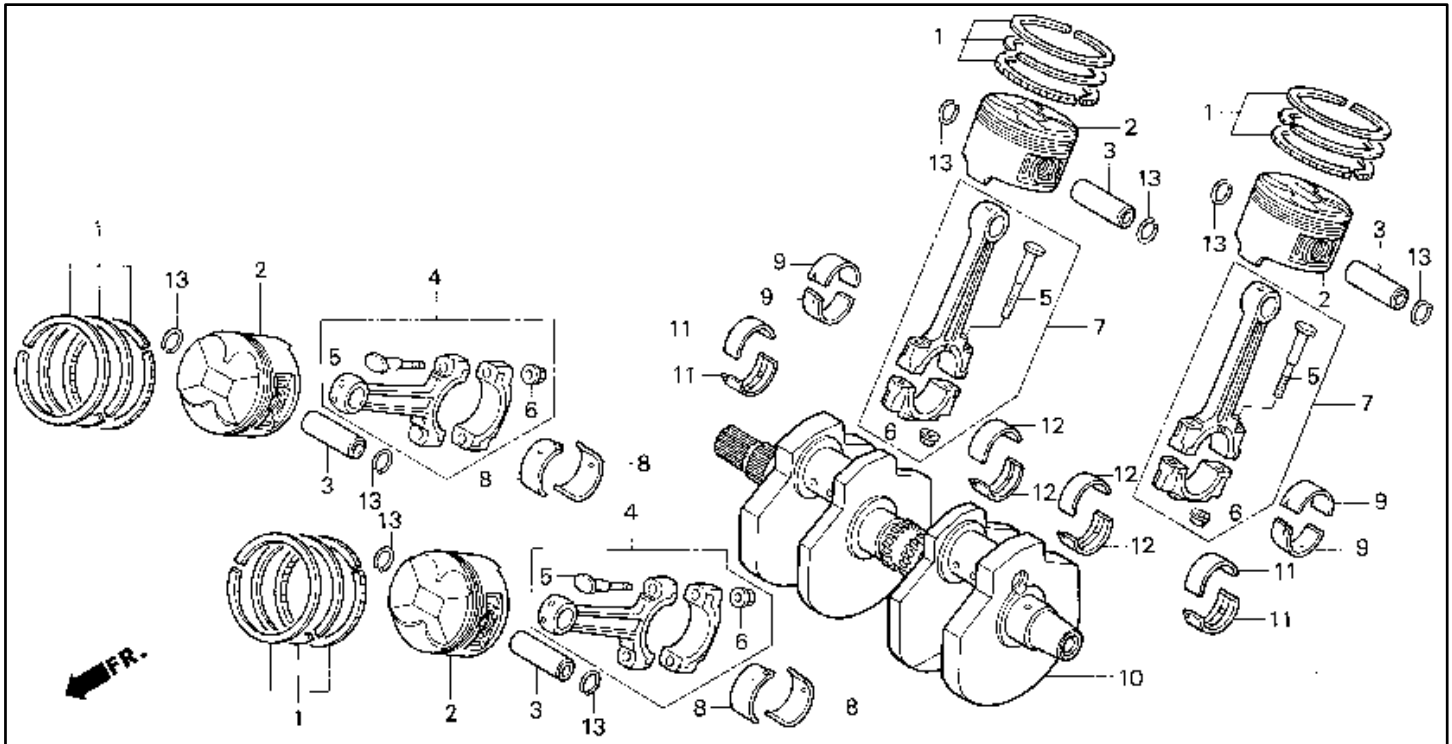

#	Description	Q'ty	Price
01	RING SET, PISTON 13011-MT4-315	004	\$39.05
01	RING SET (OS 0.25) 13021-MT4-315	004	\$35.42
01	RING SET (OS 0.50) 13031-MT4-315	004	\$38.65
02	PISTON 13101-MZ5-000	004	\$53.41
02	PISTON (OS 0.25) 13102-MZ5-305	004	\$53.41
02	PISTON (OS 0.50) 13103-MZ5-305	004	\$53.41
03	PIN, PISTON 13111-MZ5-000	004	\$18.15
04	ROD, FR. CONNECTING 13210-ML7-020	002	\$164.95
05	BOLT, CONNECTING ROD 13213-ML7-020	008	\$6.31
06	NUT, CONNECTING ROD 13215-ML7-000	008	\$3.07
07	ROD, RR. CONNECTING 13220-ML7-020	002	\$164.95
08	BEARING A, FR. 13224-ML7-690	004	\$9.09
08	BRG B, FR. CONN ROD 13225-ML7-690	004	\$9.09
08	BRG C, FR. CONN ROD 13226-ML7-690	004	\$10.18
08	BRG D, FR. CONN ROD 13227-ML7-690	004	\$8.58
08	BRG E, FR. CONN ROD 13228-ML7-690	004	\$9.09
09	BEARING A, RR. 13234-ML7-690	004	\$9.09

#	Description	Q'ty	Price
09	BRG B, RR. CONN ROD 13235-ML7-690	004	\$9.09
09	BRG C, RR. CONN ROD 13236-ML7-690	004	\$10.18
09	BRG D, RR. CONN ROD 13237-ML7-690	004	\$9.09
09	BRG E, RR. CONN ROD 13238-ML7-690	004	\$9.09
10	CRANKSHAFT 13310-MZ5-000	001	\$809.82
11	BEARING A 13313-ML7-691	004	\$10.02
11	BEARING B 13314-ML7-691	004	\$10.02
11	BEARING C 13315-ML7-691	004	\$10.02
11	BEARING D 13316-ML7-691	004	\$10.02
11	BEARING E 13317-ML7-691	004	\$10.02
12	BEARING A 13323-MR7-013	004	\$10.02
12	BEARING B 13324-MR7-013	004	\$10.02
12	BEARING C 13325-MR7-013	004	\$10.02
12	BEARING D 13326-MR7-013	004	\$10.02
12	BEARING E 13327-MR7-013	004	\$10.02
13	CLIP (17MM) 94601-17000	008	\$0.82

Cylinder Head Cover

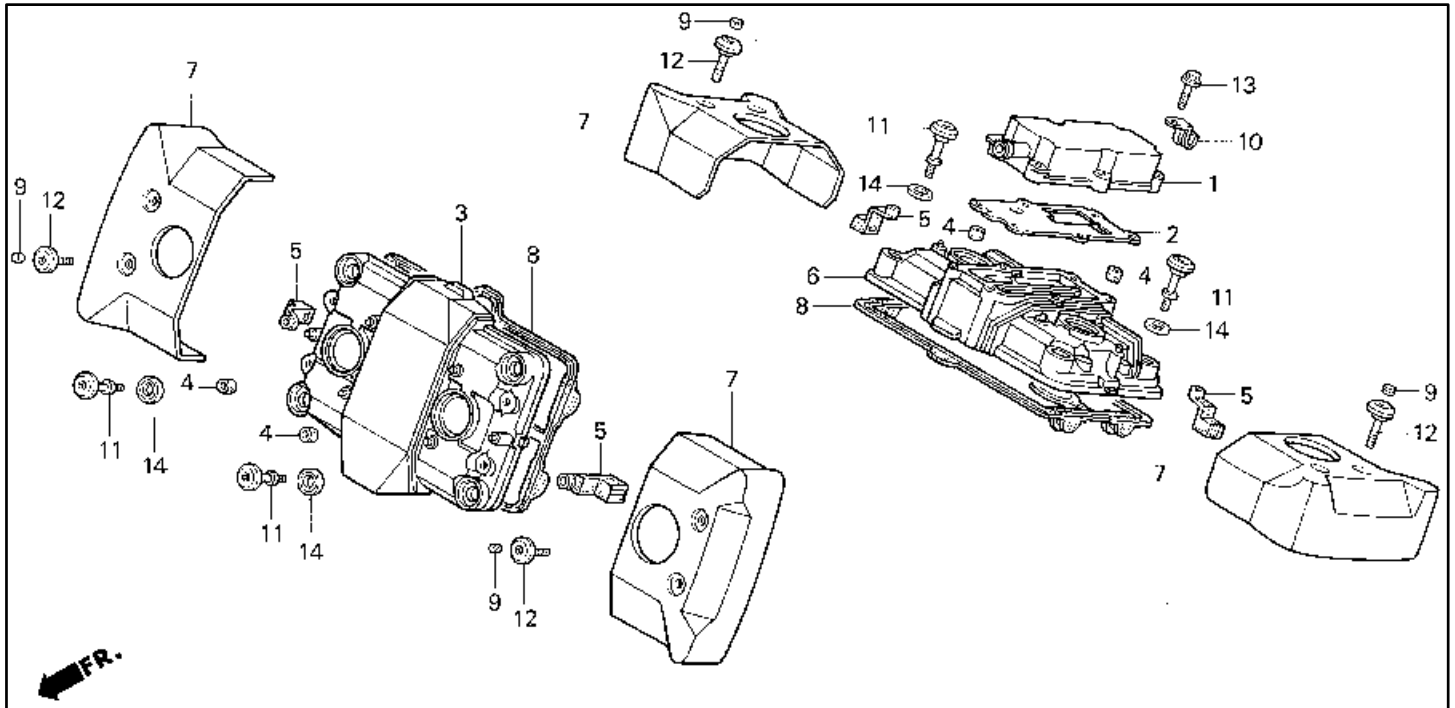

#	Description	Q'ty	Price
01	COVER, BREATHER 12230-MZ5-000	001	\$73.92
02	GASKET, BTHR CVR 12231-MZ5-920 (replaces 12231-MZ5-000)	001	\$12.02
03	COVER, FR. CYL HD 12311-MZ5-A00 (replaces 12311-MZ5-000)	001	\$166.66
04	RUBBER A 12312-MZ5-000	008	\$3.09
05	RUBBER B 12313-MZ5-000	004	\$7.04
06	COVER, RR. CYL HD 12321-MZ5-305	001	\$181.64
07	COVER A, CYL HD 12340-MZ5-000	004	\$135.39
08	GASKET, CYL HD CVR 12391-MT4-000	002	\$22.42

#	Description	Q'ty	Price
09	PLUG, HEX. (6MM) 12392-MJ0-000	008	\$3.55
10	CLIP B, TUBE 16106-KW7-900	001	\$2.38
11	BOLT, CYL HD CVR 90002-MZ5-000	008	\$8.53
12	BOLT, SPECIAL (6X34) 90003-MZ5-000	008	\$11.09
12	BOLT (6X34.5) 90003-MZ5-920	008	\$6.09
12	RUBBER, MOUNTING 90543-MZ5-920	008	\$4.42
13	BOLT, FLANGE (6X25) 90123-VA4-800	006	\$1.74
14	RUBBER, SETTING 90543-MV9-670	008	\$3.89

Evaporation Canister

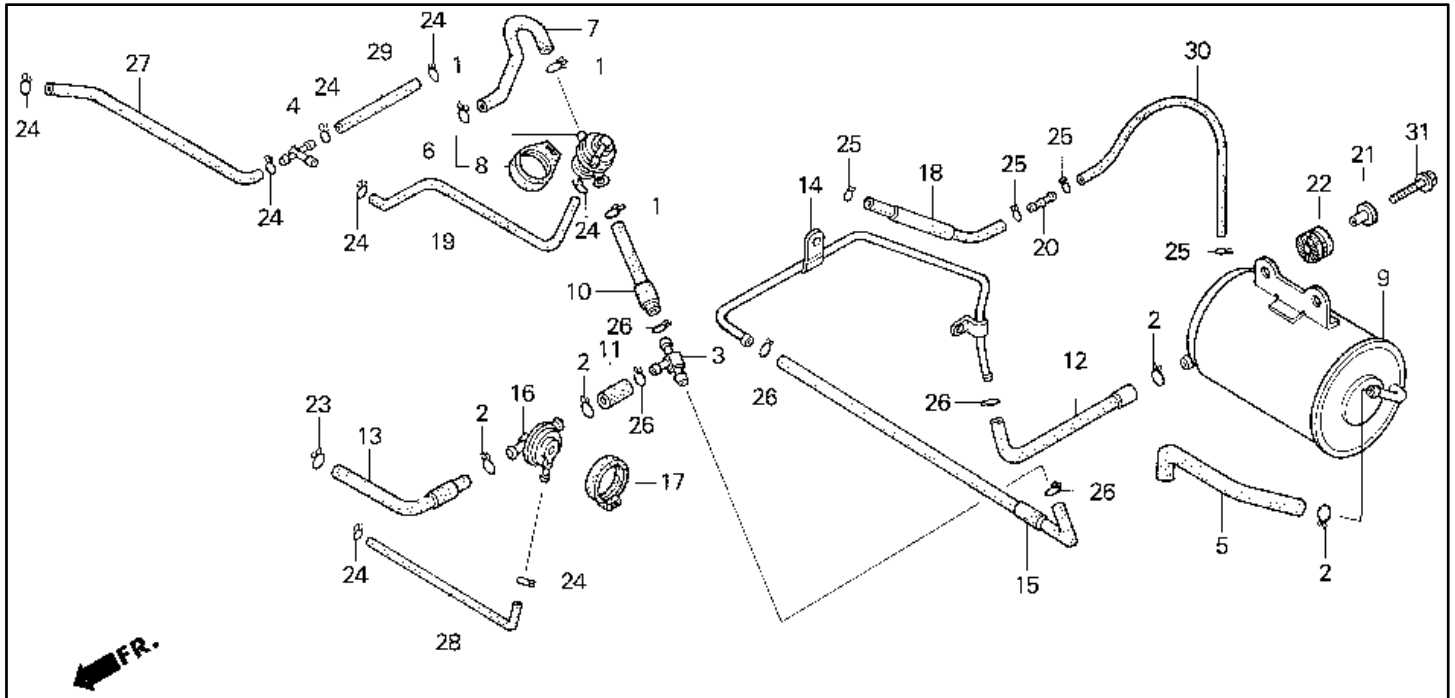

#	Description	Q'ty	Price
01	CLIP, TUBE 15772-MB3-000	003	\$1.62
02	CLIP, BREATHER TUBE 15772-500-010 (replaces 15772-500-013)	004	\$3.09
03	JOINT, FUEL TUBE 16958-MB0-000	001	\$8.29
04	JOINT, VACUUM TUBE 17201-MG9-000	001	\$12.51
05	TUBE, OPEN AIR 17290-MZ5-740	001	\$13.66
06	VALVE ASSY. 17300-MZ5-740	001	\$192.58
07	TUBE 17301-MZ5-740	001	\$14.18
08	RUBBER, SETTING 17305-MJ4-771	001	\$8.11
09	CANISTER 17410-MR1-682	001	\$241.47
10	TUBE 17411-MZ5-740	001	\$14.80
11	TUBE 17412-MZ5-740	001	\$6.98
12	TUBE 17413-MZ5-740	001	\$14.46
13	TUBE 17414-MZ5-740	001	\$16.58
14	PIPE 17415-MZ5-740	001	\$81.68
15	TUBE 17416-MZ5-740	001	\$17.44
16	VALVE 17440-MZ5-740	001	\$60.45

#	Description	Q'ty	Price
17	RUBBER 17451-ME5-760	001	\$9.24
18	TUBE 17525-MZ5-740	001	\$8.38
19	TUBE 18630-MZ5-740	001	\$12.94
20	JOINT B, WASHER TUBE 38562-663-920	001	\$4.57
21	COLLAR (6.3X13) 50324-425-010	002	\$3.96
22	RUBBER 84703-MN5-000	002	\$3.51
23	CLAMP, TUBE (12.5MM) 90661-GHB-610	001	\$1.16
24	CLIP, TUBE (B7) 95002-02070	008	\$0.82
25	CLIP, TUBE (B8) 95002-02080	004	\$0.82
26	CLIP, TUBE (B12) 95002-02120	005	\$0.90
27	BULK HOSE (3.5X1000) 95005-35001-20M	001	\$5.42
28	BULK HOSE (3.5X1000) 95005-35001-20M	001	\$5.42
29	BULK HOSE (3.5X1000) 95005-35001-20M	001	\$5.42
30	BULK HOSE (4.5X1000) 95005-45001-20M	001	\$19.42
31	BOLT, FLANGE (6X25) 95701-06025-07	002	\$0.75

Frame

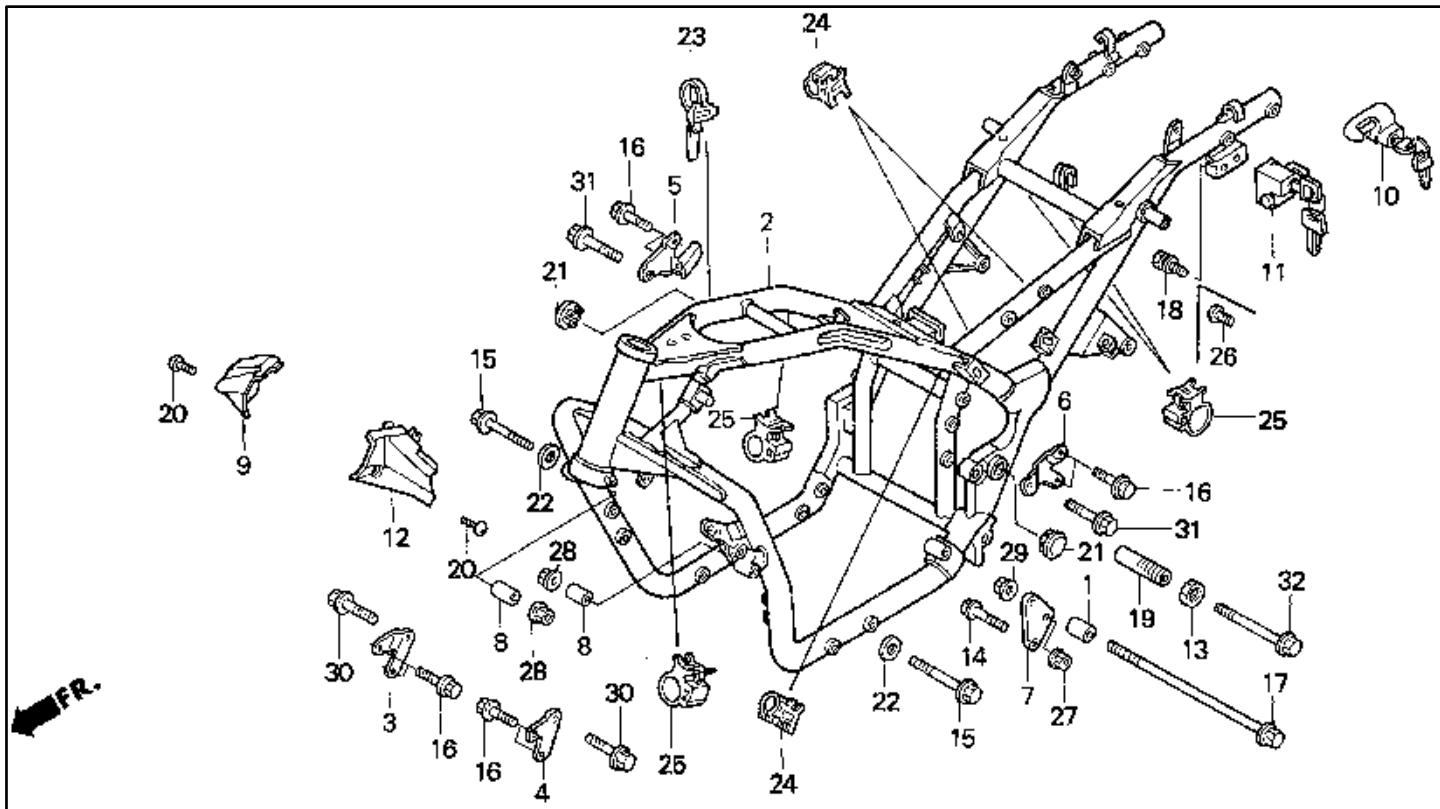

#	Description	Q'ty	Price
01	COLR, FR. WHEEL SIDE 44311-045-670	001	\$3.76
02	FRAME 50100-MZ5-600 (replaces 50100-MZ5-000)	001	\$1,794.77
02	FRAME 50100-MZ5-740	001	\$1,794.77
03	PLATE, R. FR. 50136-MZ5-000	001	\$21.64
04	PLATE, L. FR. 50137-MZ5-000	001	\$21.64
05	PLATE, R. RR. 50138-MZ5-000	001	\$29.60
06	PLATE, L. RR. 50139-MZ5-000	001	\$29.60
07	PLATE, RR. ENG HGR 50141-MZ5-000	001	\$12.00
08	COLLAR, ENG HGR 50350-MZ5-000	002	\$9.15
09	COVER, R. FR. SIDE 50650-MZ5-000	001	\$47.84
10	HOLDER ASSY., HELMET 50710-GB4-007	001	\$51.71
11	HOLDER ASSY., HELMET 50710-086-007	001	\$45.65
12	COVER, L. FR. SIDE 50750-MZ5-000	001	\$72.97
13	NUT, ACCUMULATOR 57071-SB0-800	001	\$4.04
14	BOLT, UBS (8X60) 90029-MG8-000	002	\$3.89
15	BOLT, FLG (10X105) 90101-MZ5-000	002	\$7.69

#	Description	Q'ty	Price
16	BOLT, FLANGE (8X25) 90103-MZ5-000	008	\$3.09
17	BOLT, FLG (12X265) 90105-MM8-880	001	\$17.84
18	BOLT 90107-MJ1-000	002	\$3.51
19	BOLT 90116-MZ5-000	001	\$22.76
20	SCREW, TRUSS 90133-SD4-000	002	\$1.05
21	CAP, R. LOCK NUT 90302-ME5-000	002	\$13.84
22	WASHER, FLAT (10MM) 94102-10700 (replaces 90503-MZ5-000)	002	\$0.57
23	CLIP (15) 90690-GHB-601	001	\$1.69
24	CLIP, CABLE (8MM) 90690-GHB-631	003	\$1.60
25	CLIP, CABLE (25MM) 90690-GHB-671	004	\$1.60
27	NUT, FLANGE (8MM) 94050-08070	002	\$0.33
28	NUT, FLANGE (10MM) 90303-428-900 (replaces 94050-10070)	002	\$2.62
29	NUT, FLANGE (12MM) 94050-12000	001	\$0.76
30	BOLT, FLANGE (10X35) 95701-10035-07	002	\$1.35
31	BOLT, FLANGE (10X45) 95701-10045-02	002	\$2.45
32	BOLT, FLANGE (10X85) 95701-10085-00	001	\$1.95

Front Brake Caliper

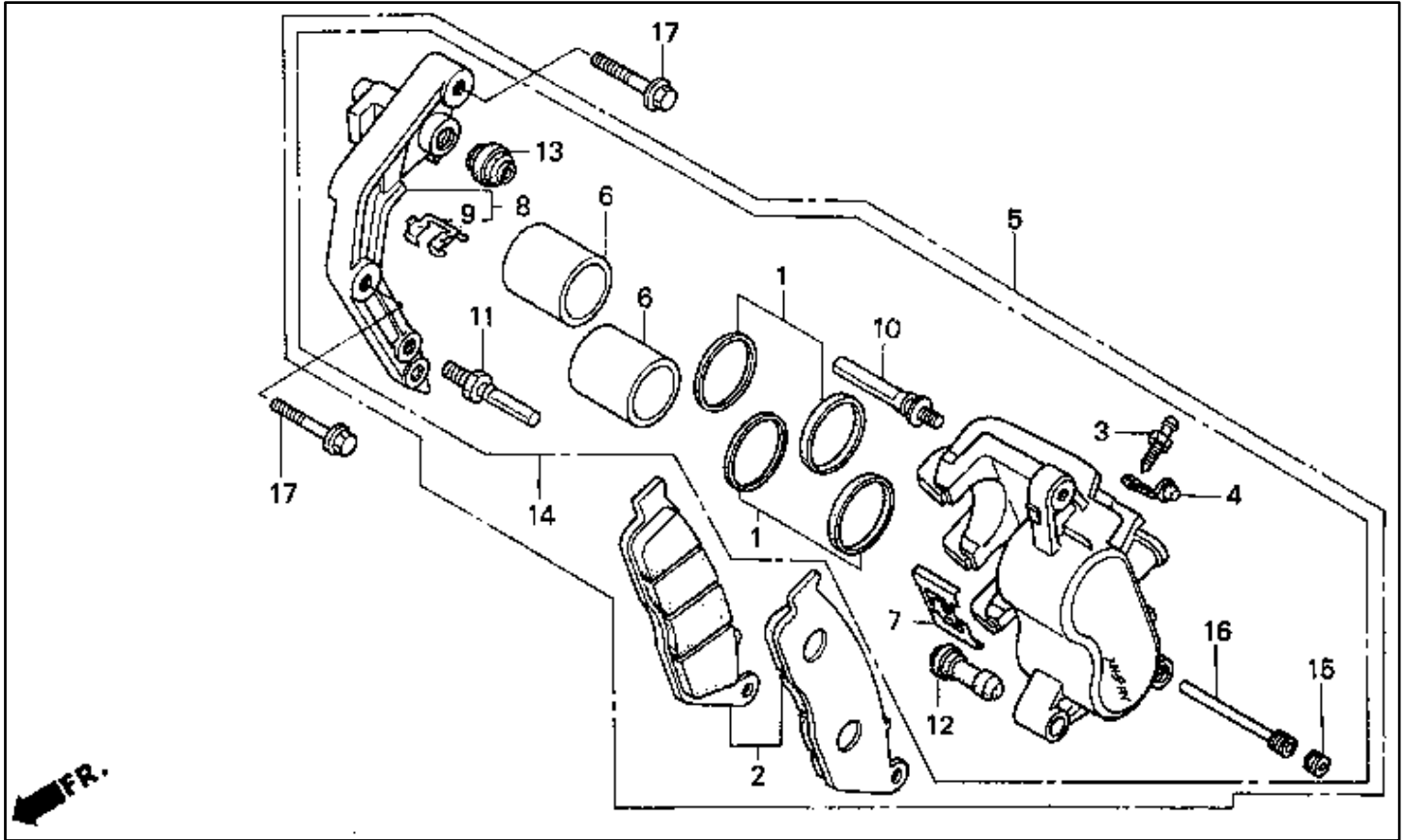

#	Description	Q'ty	Price
01	SEAL SET, PISTON 06451-GE2-405	002	\$8.67
02	PAD SET, FR. 06455-MS9-405	001	\$40.00
03	SCREW, BLEEDER 43352-568-003	001	\$5.07
04	CAP, BLEEDER 43353-461-771	001	\$3.96
05	CLPR, L. FR. BRAKE 45100-MZ5-006	001	\$412.36
06	PISTON 45107-MN5-006	002	\$28.75
07	SPRING, PAD 45108-ML7-922	001	\$4.85
08	BRACKET, L. FR. 45110-MZ6-006	001	\$91.77
09	RETAINER 45112-MS9-611	001	\$4.29

#	Description	Q'ty	Price
10	BOLT A, PIN 45131-ML7-921	001	\$11.71
11	PIN, BOLT 45131-166-016	001	\$6.00
12	BUSH, PIN 45132-166-016	001	\$4.29
13	BOOT B 45133-MA3-006	001	\$4.29
14	CALIPER SUB-ASSY. 45150-MZ5-305	001	\$342.69
15	PLUG, PIN 45203-MG3-016	001	\$4.00
16	PIN, HANGER 45215-ML7-922	001	\$8.11
17	BOLT (8X32) 90101-MZ8-000	002	\$5.31

Front Brake Master Cylinder

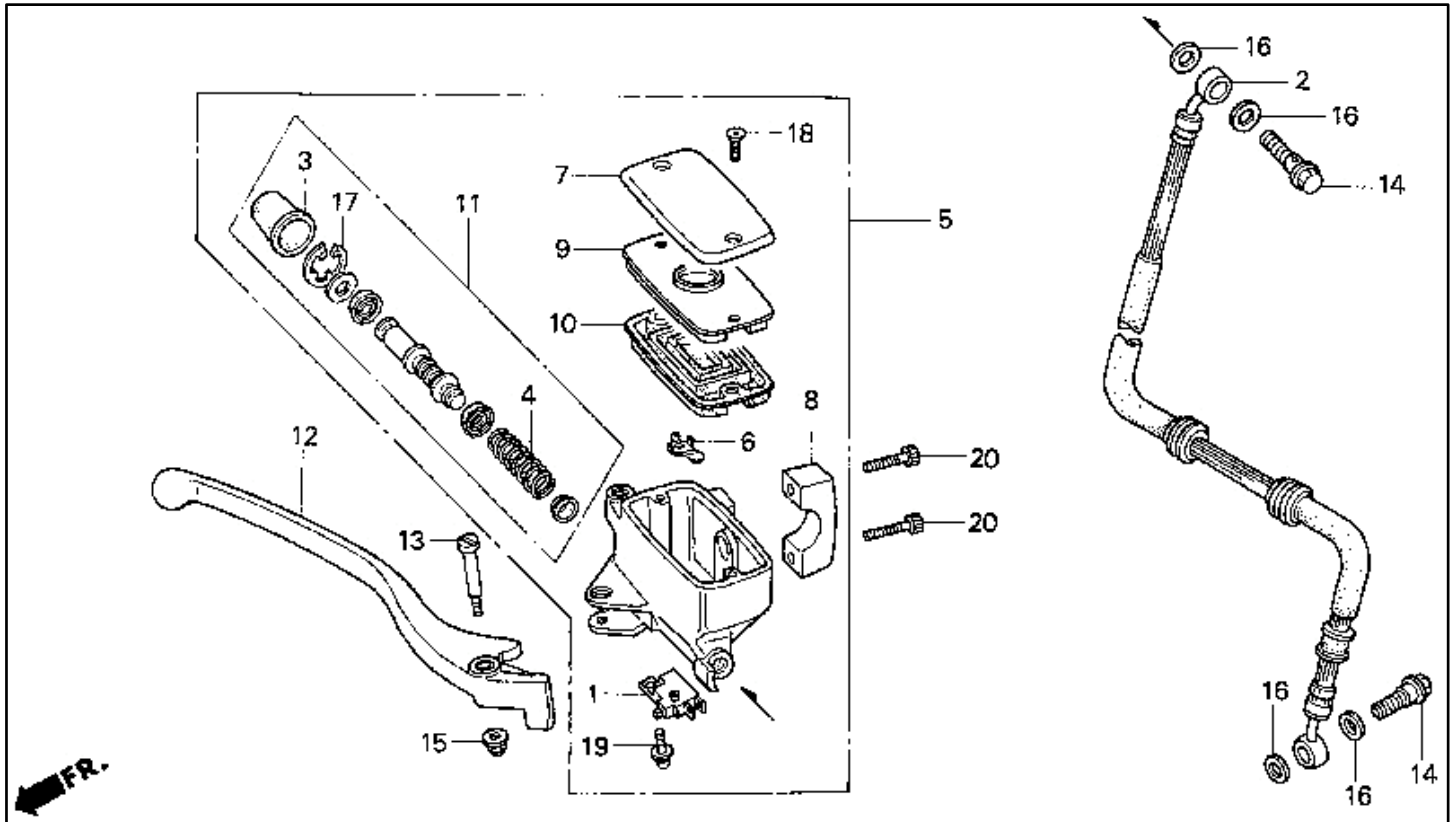

#	Description	Q'ty	Price
01	SWITCH, FR. STOP 35340-MM5-600	001	\$15.44
02	HOSE, FR. BRAKE 45126-MZ5-003	001	\$55.67
03	BOOT 45504-410-003	001	\$9.24
04	SPRING 45506-KA3-731	001	\$4.15
04	SPRING 45506-KA3-831	001	\$3.71
05	M/CYL SUB-ASSY, FR. 45510-MZ8-305	001	\$241.36
06	PROTECTOR 45512-MA6-006	001	\$3.38
07	CAP, MASTER CYLINDER 45513-MR1-016 (replaces 45513-MR1-006)	001	\$23.25
08	HOLDER 45517-MR1-671	001	\$19.49
09	PLATE, DIAPHRAGM 45518-MM5-006	001	\$8.09
10	DIAPHRAGM 45520-MM5-006	001	\$11.47

#	Description	Q'ty	Price
11	MASTER CYLINDER SET 45530-MN9-305	001	\$38.51
12	LEVER, R. HANDLEBAR 53175-MR1-671	001	\$14.31
13	BOLT, R. 90114-MA5-671	001	\$7.15
14	BOLT, OIL (10X22) 90145-MS9-612 (replaces 90145-MS9-611)	002	\$5.29
15	NUT, CAP (6MM) 90201-415-000	001	\$1.58
16	WASHER, OIL BOLT 90545-300-000	004	\$2.18
17	CIRCLIP 90651-MA5-671	001	\$2.07
18	SCREW, FLAT (4X12) 93600-04012-1A	002	\$0.32
19	SCREW-WASHER (4X12) 93893-04012-07 (replaces 93893-04012-17)	001	\$0.70
20	BOLT, SOCKET (6X22) 96600-06022-10 (replaces 96700-06022-10)	002	\$1.20

Front Cylinder Head

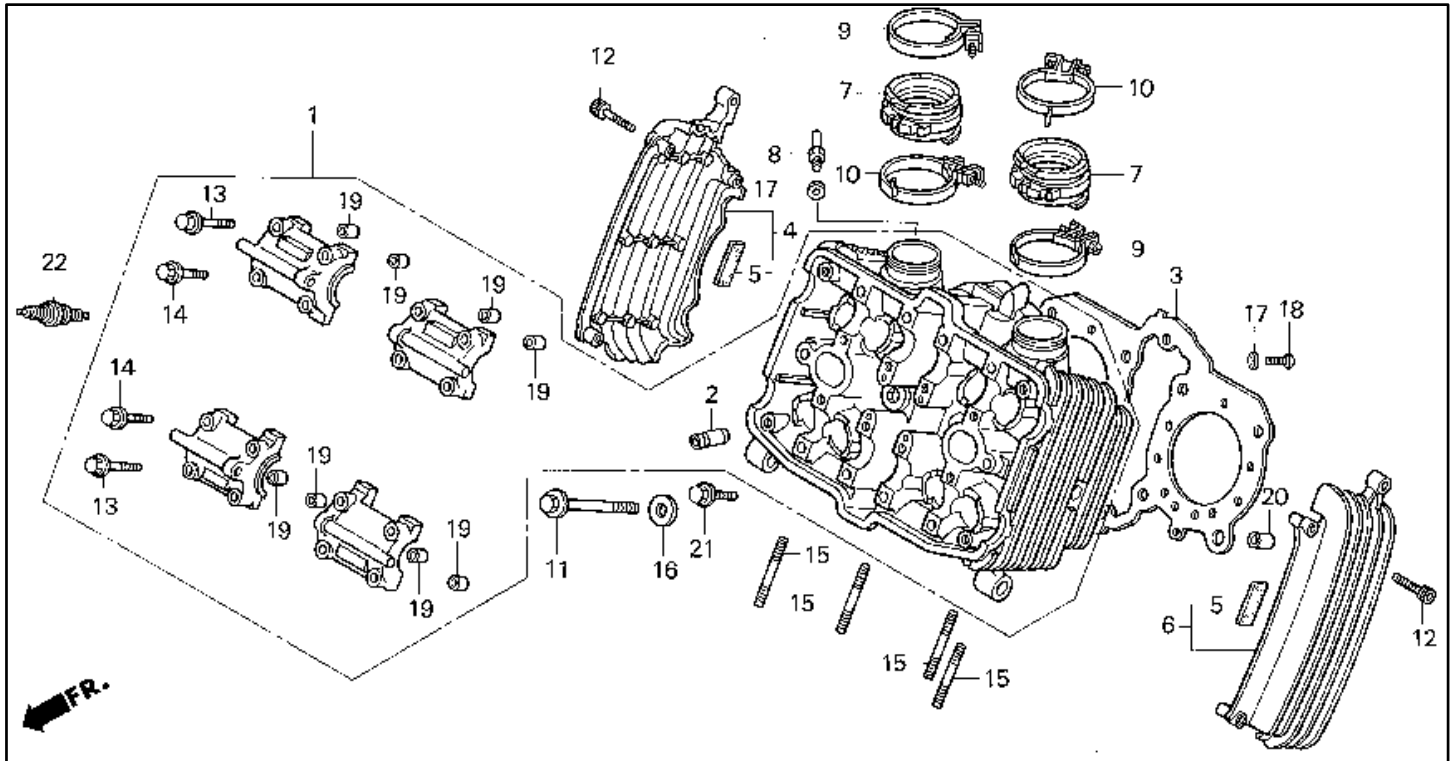

#	Description	Q'ty	Price
01	CYLINDER HEAD, FR. 12010-MZ5-315	001	\$834.03
01	CYLINDER HEAD, FR. 12010-MZ5-316	001	\$834.03
02	GUIDE, VALVE (OS) 12204-MT4-305	008	\$16.15
03	GASKET, CYL HD 12251-MT4-014 (replaces 12251-MT4-004)	001	\$46.67
04	FIN A, CYLINDER HEAD 12350-MZ5-000	001	\$113.93
05	RUBBER, SEAT 12352-MZ5-300	002	\$2.44
06	FIN B, CYLINDER HEAD 12360-MZ5-000	001	\$73.62
07	INSULATOR, CARB 16211-MZ5-000	002	\$38.78
08	JOINT, BOOSTER 16214-MB0-000	001	\$3.51
09	BAND A, INSULATOR 16219-MM4-000	002	\$8.07
10	BAND B, INSULATOR 16220-MM4-000	002	\$8.07
11	BOLT, FLANGE (9X93) 90007-ML7-920	008	\$7.85

#	Description	Q'ty	Price
12	BOLT, SOCKET (6X28) 90012-MZ5-000	006	\$1.60
13	BOLT, FLG (6X45.5) 90017-MA6-000	008	\$2.62
14	BOLT, FLG (6X39.5) 90019-MA6-000	008	\$2.25
15	BOLT, STUD (6X28) 90035-MZ5-000	004	\$3.87
16	WASHER (9MM) 90445-MM4-000	008	\$2.82
17	WASHER (5MM) 90452-323-000	002	\$0.85
18	SCREW, PAN (5X8) 93500-05008-0A	001	\$0.45
19	PIN, DOWEL (8X14) 94301-08140	008	\$1.00
20	PIN, DOWEL (12X20) 94301-12200	002	\$1.17
21	BOLT, FLANGE (6X30) 95701-06030-00	002	\$0.83
22	SPARK PLUG (CR9EH9) 98059-59916 (replaces 98059-58926, 98059-59910)	002	\$8.14

Front Fender

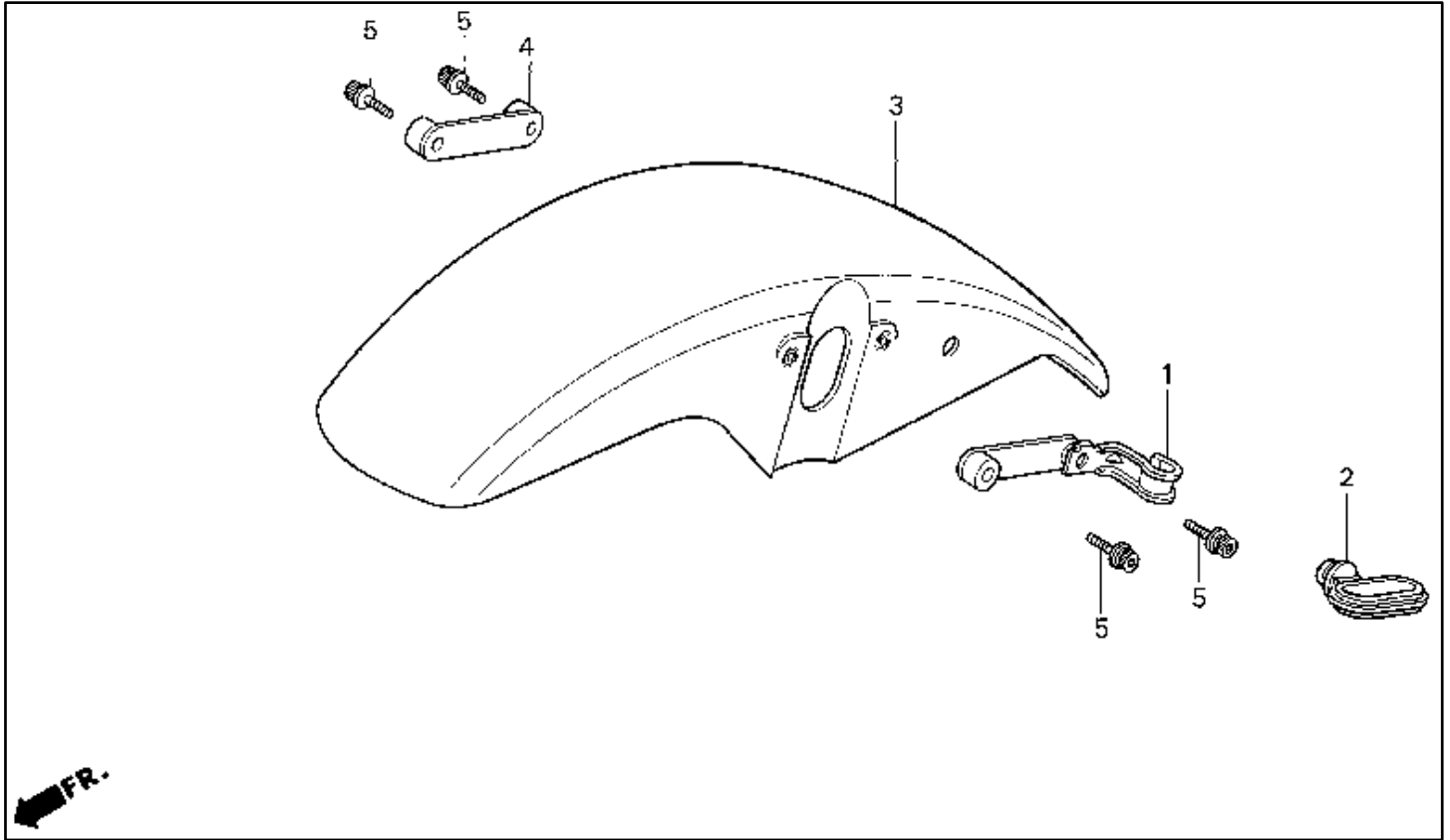

#	Description	Q'ty	Price
01	CLAMP B, BRAKE HOSE 45158-MZ5-000	001	\$16.56
02	GUIDE, FR. 45451-473-000	001	\$5.15
03	FENDER, FR. *NH1* 61100-MZ5-000ZC	001	\$154.96
03	FENDER, FR. *Y124P* 61100-MZ5-000ZD	001	\$154.96

#	Description	Q'ty	Price
03	FENDER, FR. *R201* 61100-MZ5-000ZE	001	\$154.96
04	PLATE, FR. FENDER 61103-MZ5-000	001	\$11.33
05	BOLT (6X25) 90080-MG8-000	004	\$3.07

Front Fork

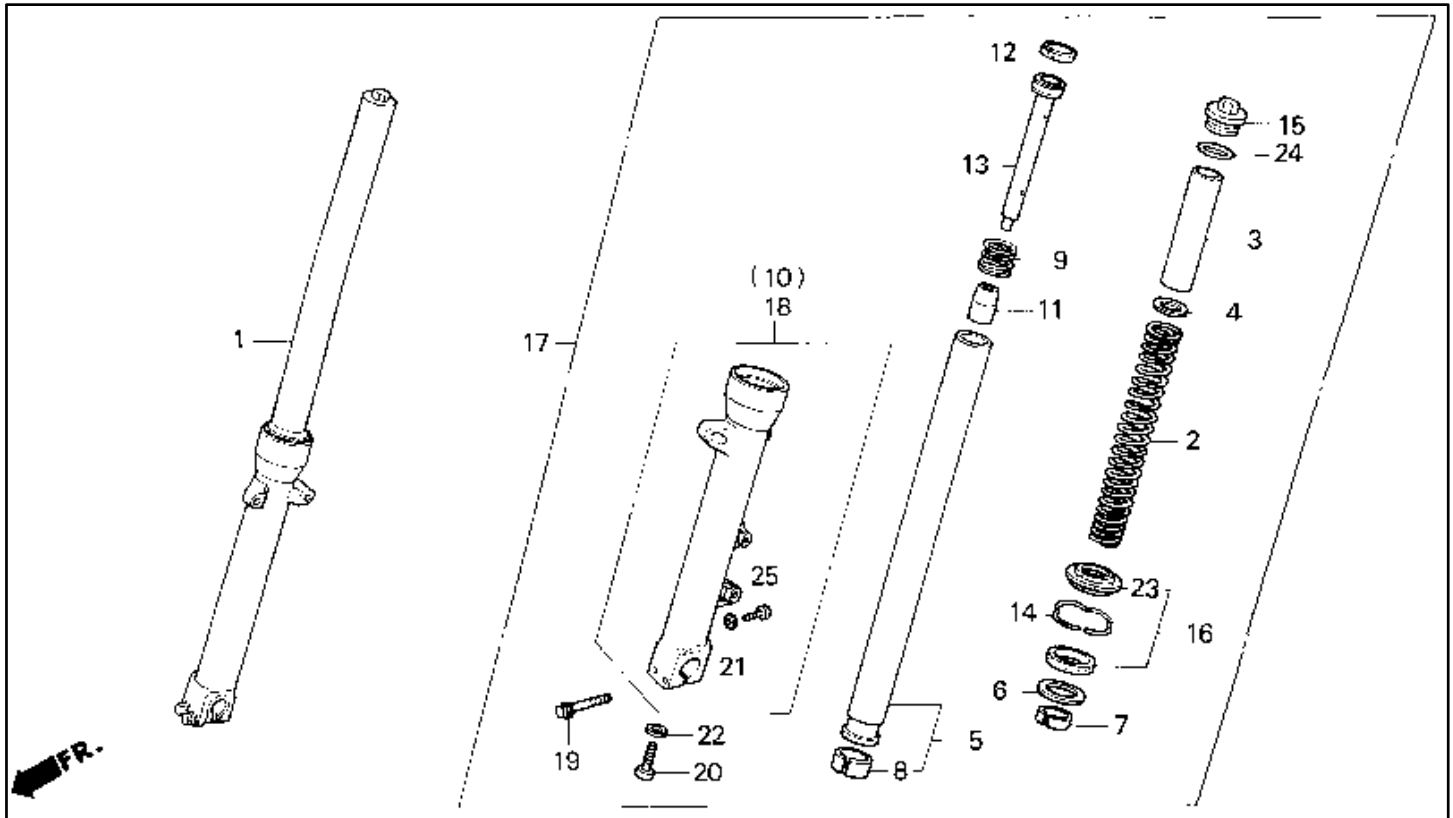

#	Description	Q'ty	Price
01	FORK ASSY., R. FR. 51400-MZ5-912 (replaces 51400-MZ5-671)	001	Call For Price
02	SPRING, FR. FORK 51401-MZ5-671	002	\$66.38
03	COLLAR, SPRING 51402-KV3-701	002	\$18.24
04	SEAT, SPRING 51403-KF0-003	002	\$3.76
05	PIPE, FR. FORK 51410-MZ5-671	002	\$246.51
06	RING, BACK-UP 51412-MB4-003	002	\$7.33
07	BUSH, GUIDE 51414-KCR-003 (replaces 51414-MN5-003)	002	\$10.64
08	BUSH, SLIDER 51415-KCR-003 (replaces 51415-MM8-003)	002	\$8.78
09	SPRING, FR. REBOUND 51416-KF0-003	002	\$5.22
10	CASE, R. (LOWER) 51420-MZ5-912 (replaces 51420-MZ5-671)	001	\$295.28
11	PIECE, OIL LOCK 51432-MV9-003	002	\$18.85
12	RING, PISTON 51437-MM5-003	002	\$4.22
13	PIPE, SEAT 51440-MZ5-671	002	\$48.46

#	Description	Q'ty	Price
14	RING 51447-KA4-711	002	\$3.55
15	BOLT, FR. FORK 51454-MM9-671	002	\$44.11
16	SEAL SET, FR. FORK 51490-MN8-305	002	\$25.16
17	FORK ASSY., L. FR. 51500-MZ5-912 (replaces 51500-MZ5-671)	001	Call For Price
18	CASE, L. (LOWER) 51520-MZ5-671	001	\$218.67
18	CASE, L. (LOWER) 51520-MZ5-912	001	\$218.67
19	BOLT, FLANGE (8X45) 90109-MR7-000	004	\$3.89
20	BOLT, SOCKET (8MM) 90116-KV3-701	002	\$3.07
21	GASKET, FR. 90543-273-000	002	\$1.60
22	WASHER (8MM) 90544-283-000	002	\$2.05
23	DUST SEAL 91254-MM8-003	002	\$13.55
24	O-RING (21.7X3.5) 91356-KF0-003	002	\$2.93
25	BOLT, HEX. (6X8) 92101-06008-0A	002	\$0.63

Front Wheel

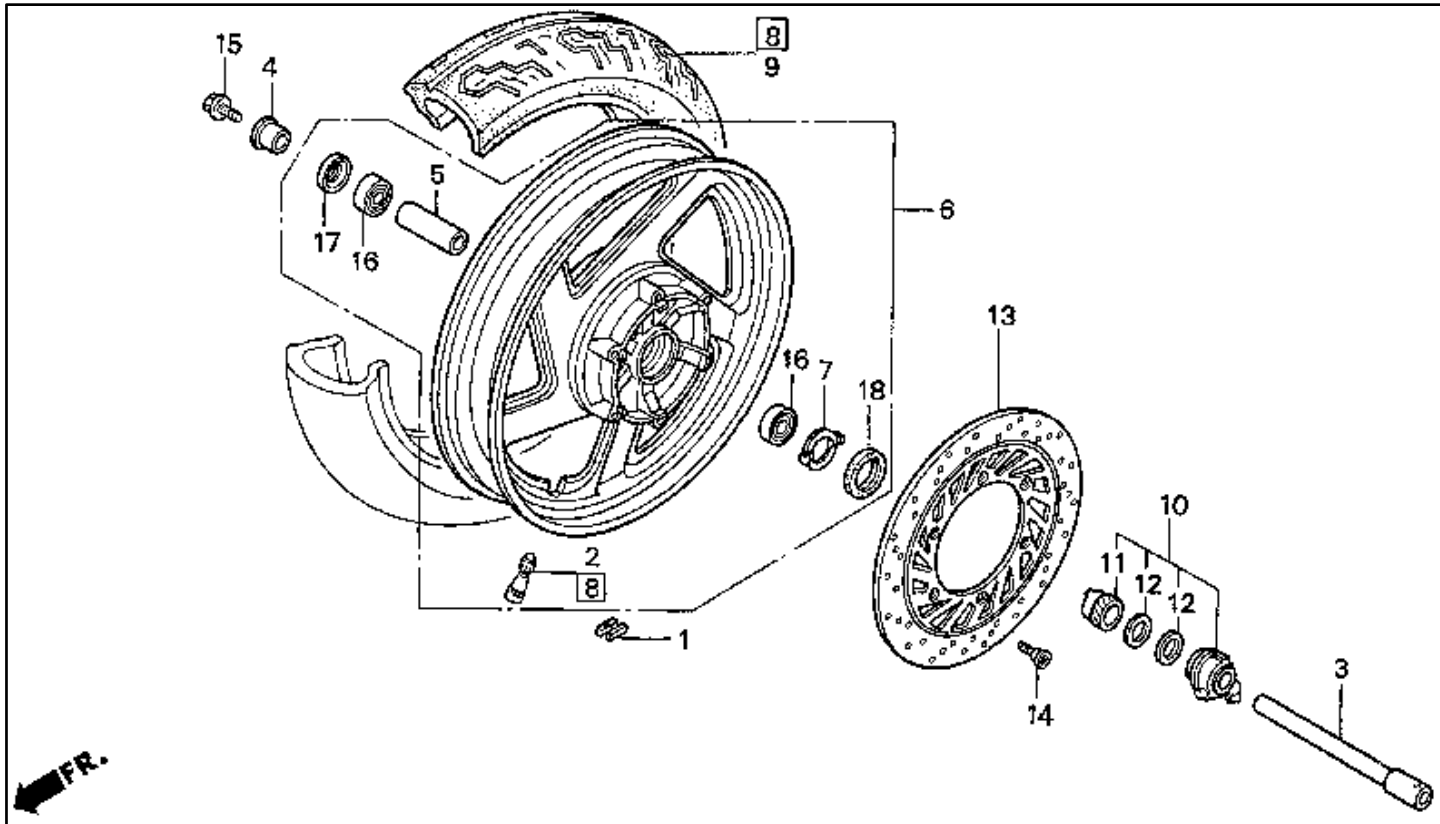

#	Description	Q'ty	Price
01	WEIGHT (10G) 42704-MB0-000	AR	\$9.07
01	WEIGHT (20G) 42705-MB0-000	AR	\$10.36
01	WEIGHT, BALANCE (20) 42705-MCF-D60	AR	\$10.36
01	WEIGHT, BALANCE (30) 42706-MCF-D60 (replaces 42706-MB0-000)	AR	\$10.36
02	VALVE, RIM 42753-ML7-004	001	\$9.67
03	AXLE, FR. WHEEL 44301-MZ5-000	001	\$47.29
04	COLR, FR. WHEEL SIDE 44311-MM8-000	001	\$13.69
05	COLLAR, FR. 44620-MT3-000	001	\$13.07
06	WHEEL SUB-ASSY., FR. 44650-MZ5-335 (replaces 44650-MZ5-305, 44650-MZ5-315, 44650-MZ5-325)	001	\$526.65
07	RETAINER, GEAR BOX 44680-ML7-000	001	\$3.76
08	TIRE (120/80-17) 44711-MZ5-024 (replaces 44710-MZ5-004, 44711-MZ5-004, 44711-MZ5-014)	001	\$138.46

#	Description	Q'ty	Price
08	TIRE (120/80-17) 44711-MZ5-024	001	\$138.46
10	BOX ASSY. 44800-ML7-691	001	\$73.35
11	GEAR, SPEEDOMETER 44806-ML7-691	001	\$22.22
12	WASHER 44809-ML7-003	002	\$2.25
13	DISK, FR. BRAKE 45251-MS9-750	001	\$273.18
14	BOLT, DISK (8X24) 90105-MV9-003	006	\$4.87
15	BOLT, FR. AXLE 90305-ML7-000	001	\$7.96
16	BEARING (6004UU) 91054-MAM-003 (replaces 91054-MN8-741)	002	\$24.45
17	DUST SEAL (28X42X8) 91257-MAY-003 (replaces 91257-KA3-711, 91257-KA3-712)	001	\$6.93
18	DUST SEAL (45X55X5) 91258-ML7-003 (replaces 91258-ML7-004)	001	\$6.56

Fuel Tank

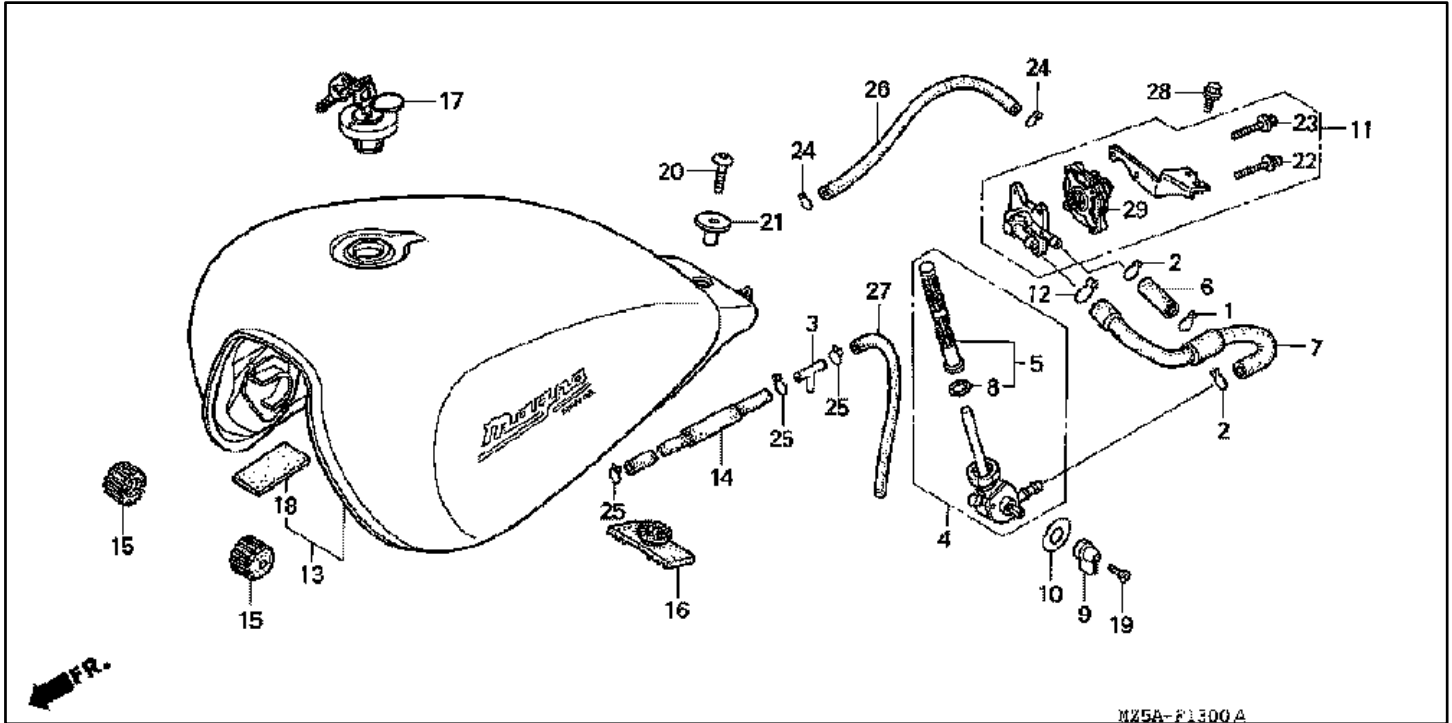

MZ5A-F1300A

#	Description	Q'ty	Price
01	CLIP, OIL DRAIN TUBE 15771-551-000	001	\$5.73
02	CLIP, BREATHER TUBE 15772-500-010 (replaces 15772-500-013)	002	\$3.20
03	T-JOINT 16180-195-731	001	\$10.18
04	PETCOCK ASSY. 16950-MZ5-672 (replaces 16950-MZ5-670, 16950-MZ5-671)	001	\$79.82
05	SCREEN SET 16952-KAZ-000	001	\$20.44
06	TUBE B, FUEL 16952-MZ5-000	001	\$1.33
07	TUBE A, FUEL 16956-MZ5-000	001	\$10.40
08	O-RING 16958-KM9-005	001	\$2.95
09	LEVER, PETCOCK 16963-MZ5-000	001	\$7.40
10	MARK, FUEL 16965-MZ5-300	001	\$6.09
11	PETCOCK ASSY., AUTO 16970-MZ5-003 (replaces 16970-MZ5-000)	001	\$155.16
12	CLIP, BREATHER TUBE 17316-611-000	001	\$5.55
13	TANK, FUEL (TYPE5) 17520-MZ5-A40ZA	001	\$590.71
14	TUBE 17525-MZ5-000	001	\$13.18
15	CUSHION, FR. 17611-KE5-000	002	\$4.15

#	Description	Q'ty	Price
16	RUB. RR. FUEL TANK 17613-MR7-000	001	\$12.55
17	CAP, FUEL FILLER 17620-KR3-751	001	\$66.87
18	PROTECTOR, HOSE 64233-MR7-300	002	\$4.04
19	SCREW, OVAL (6X12) 90111-MZ5-000	001	\$2.82
20	BOLT 90128-KL4-000	001	\$7.24
21	COLLAR 90502-MZ5-000	001	\$3.62
22	SCREW-WASHER (4X16) 93892-04016-00 (replaces 93892-04016-10)	002	\$0.33
23	SCREW-WASHER (4X20) 93892-04020-10	002	\$1.35
24	CLIP, TUBE (B7) 95002-02070	002	\$0.85
25	CLIP, TUBE (B8) 95002-02080	003	\$0.85
26	BULK HOSE (3.5X1000) 95005-35001-20M	001	\$5.62
27	BULK HOSE (4.5X1000) 95005-45001-20M	001	\$20.17
28	BOLT, FLANGE (6X12) 96001-06012-00	002	\$0.82
29	COVER SET, PETCOCK 16953-MN5-023 (replaces 16953-MN5-003)	001	\$42.18

Gasket Kit A

#	Description	Q'ty	Price
00	GASKET KIT A 06111-MZ5-010 (replaces 06111-MZ5-000)	001	\$171.63
01	GSKT, TENSIONER HOLE 12194-HC5-740	001	\$1.78
02	GSKT, TENSIONER HOLE 12194-KW3-880	001	\$1.67
03	SEAL, EX. VALVE STEM 12208-ML0-721	008	\$8.07
04	SEAL, VALVE STEM 12209-MZ5-003	008	\$7.69
05	GASKET, BTHR CVR 12231-MZ5-920 (replaces 12231-MZ5-000)	001	\$12.02

#	Description	Q'ty	Price
06	GASKET, CYL HD 12251-MT4-014 (replaces 12251-MT4-004)	002	\$46.67
07	GASKET, CYL HD CVR 12391-MT4-000	002	\$22.42
08	GASKET, EX. PIPE 18291-MN4-920	004	\$4.22
09	WASHER (6.5MM) 90463-ML7-000	002	\$2.25
10	RUBBER, SETTING 90543-MV9-670	008	\$3.89
11	O-RING (21.2X2.4) 91331-PC9-003	002	\$1.95

Gasket Kit B

#	Description	Q'ty	Price
00	GASKET KIT B 06112-MZ5-000	001	\$58.31
01	GASKET, OIL PAN 11315-MY7-000	001	\$10.31
02	GASKET, L. 11343-MZ5-000	001	\$4.57
03	GASKET, R. 11394-MY7-000	001	\$18.08
04	GASKET, SHIFT COVER 11632-MY7-000	001	\$9.47
05	GASKET 11636-MY7-000	001	\$12.98
06	GASKET, OIL STRAINER 15154-ML7-000	001	\$5.20
07	GASKET 19226-ML7-000	001	\$3.53
08	WASHER (10MM) 90403-MG7-000	002	\$2.62
09	WASHER (6.5MM) 90463-ML7-000	006	\$2.25
10	GSKT, CONNECTING CAP 91301-MB0-000	002	\$3.05
11	O-RING (48.1X3.6) 91301-ML7-003	001	\$3.11

#	Description	Q'ty	Price
12	O-RING (18.3X2.3) 91301-147-023	002	\$1.42
13	O-RING (22X3.0) 91307-425-003 (replaces 91301-250-000)	001	\$1.47
14	O-RING (32.95X2.62) 91302-MB0-013	001	\$2.07
15	O-RING (6X2) 91307-ML7-004	002	\$1.87
16	O-RING 91309-MAG-000	001	\$2.93
17	O-RING (14.6X3.7) 91309-MB0-003	002	\$2.93
18	O-RING (14.8X2.2) 91313-MG7-004 (replaces 91313-MB0-003)	001	\$2.35
19	O-RING (7.7X2.3) 91301-PC9-003 (replaces 91308-283-000, 91313-393-003)	001	\$1.45
20	SEAL, WATER PIPE 91315-MB0-013	001	\$1.95
21	O-RING (8.4X2.4) 91316-MJ8-003	001	\$1.87
22	O-RING (21.2X2.4) 91331-PC9-003	001	\$1.95
23	WASHER, DRAIN (12MM) 94109-12000	001	\$0.50

Gearshift Drum

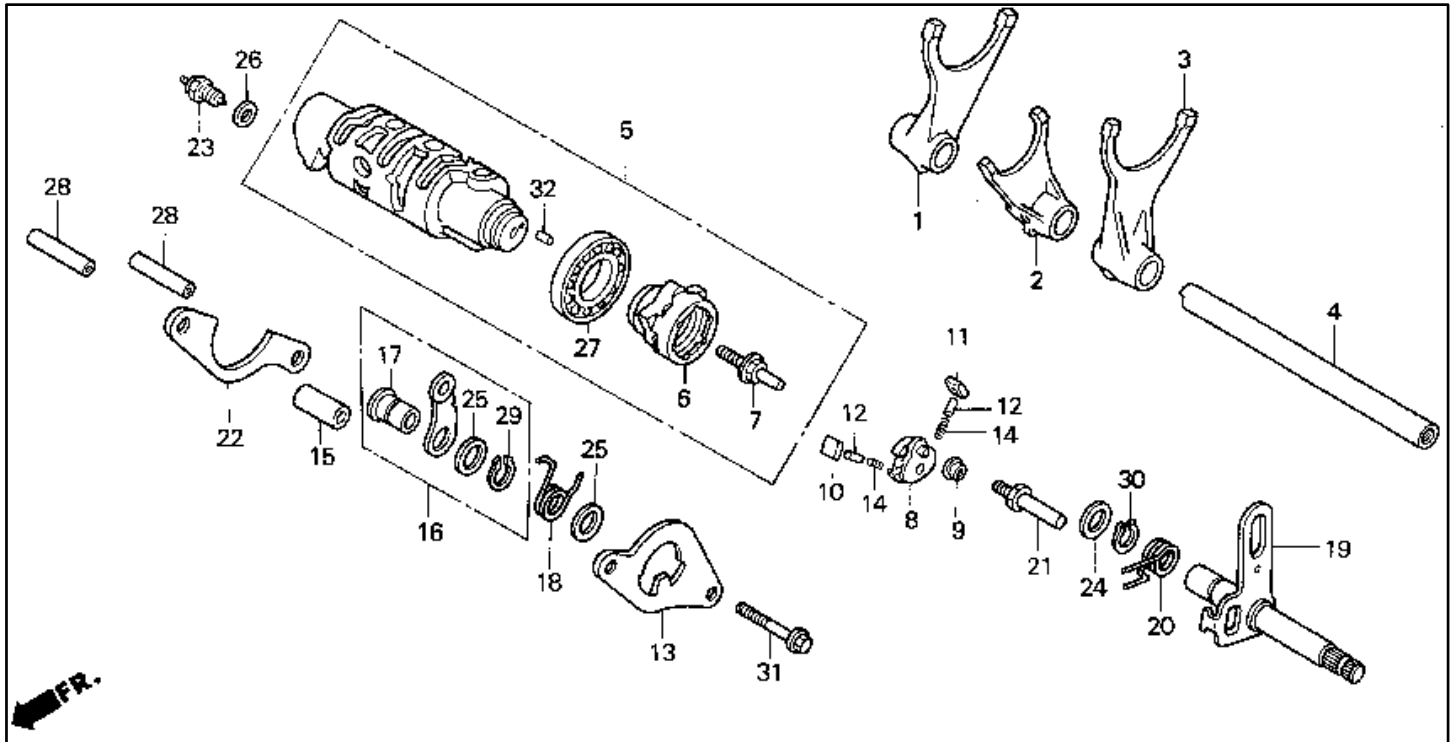

#	Description	Q'ty	Price
01	FORK, R. GEARSHIFT 24211-MZ5-000	001	\$52.64
02	FORK 24212-ML7-000	001	\$58.36
03	FORK, L. GEARSHIFT 24213-ML7-000	001	\$66.61
04	SHAFT 24261-ML7-000	001	\$35.95
05	DRUM, GEARSHIFT 24310-MZ5-000	001	\$132.91
06	CENTER 24312-KT7-752	001	\$26.78
07	PIN, SHIFTER 24315-HA0-000	001	\$9.58
08	SHIFTER, DRUM 24321-KT8-030	001	\$39.36
09	COLLAR, SHIFTER 24322-MM4-000	001	\$4.00
10	PAWL A, RATCHET 24324-KA3-711	001	\$10.02
11	PAWL B, RATCHET 24325-KA3-711	001	\$10.02
12	PLUNGER, PAWL 24326-KBH-901	002	\$4.56
13	PLATE, GUIDE 24328-MR7-010	001	\$13.07
14	SPRING, PAWL PLUNGER 24329-KA3-740	002	\$2.07
15	COLLAR 24329-KT7-000	001	\$3.89
16	STOPPER, DRUM 24430-MR7-000	001	\$18.04

#	Description	Q'ty	Price
17	COLLAR, DRUM STOPPER 24434-MR7-000	001	\$6.36
18	SPRING 24435-KBV-000	001	\$3.40
19	SPINDLE, GEARSHIFT 24610-MR7-000	001	\$79.90
20	SPRING 24651-MR7-000	001	\$5.71
21	PIN 24652-035-000	001	\$3.13
22	PLATE 24655-MR7-000	001	\$9.67
23	SWITCH, NEUTRAL 35600-KE8-003 (replaces 35600-KE8-010)	001	\$14.33
24	WASHER (14MM) 90451-155-000	001	\$3.15
25	WASHER (12MM) 90485-MR7-000	002	\$3.76
26	WASHER, OIL BOLT 90545-300-000	001	\$2.18
27	BEARING (16005) 91008-374-003	001	\$11.40
28	PIN, DOWEL (8X31.5) 91104-KT7-000	002	\$3.51
29	CIRCLIP (12MM) 94510-12000	001	\$1.02
30	CIRCLIP (14MM) 94510-14000	001	\$0.57
31	BOLT, FLANGE (6X45) 95701-06045-07 (replaces 95701-06045-00)	002	\$0.97
32	ROLLER (4X8) 96220-40080	001	\$0.33

Handle Switch Cables

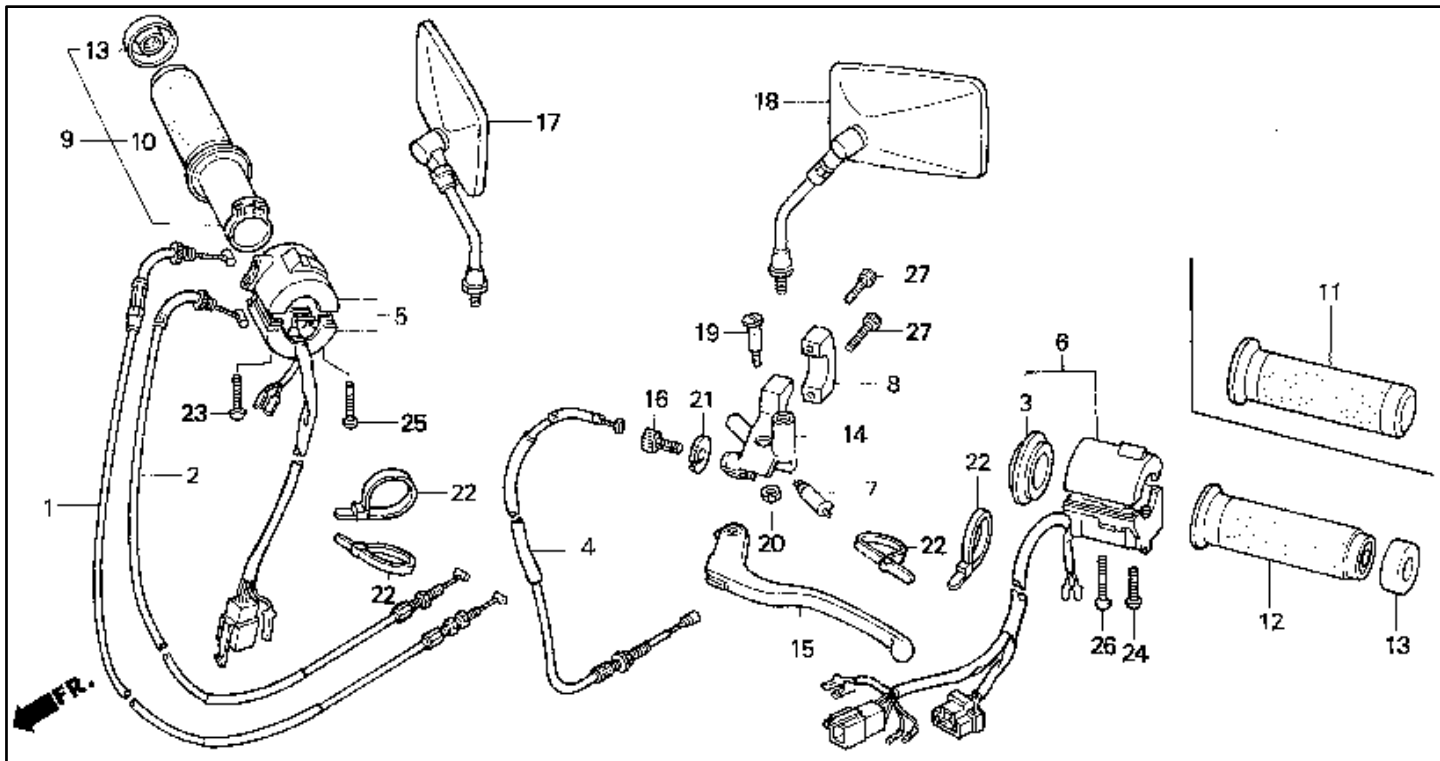

#	Description	Q'ty	Price
01	CABLE A, THROTTLE 17910-MZ5-910 (replaces 17910-MZ5-000, 17910-MZ5-770)	001	\$25.63
02	CABLE B, THROTTLE 17920-MZ5-910 (replaces 17920-MZ5-000, 17920-MZ5-770)	001	\$25.63
03	ADAPTER 17962-MR1-000	001	\$14.64
04	CABLE, CLUTCH 22870-MZ5-770 (replaces 22870-MZ5-000)	001	\$26.47
05	SWITCH, STARTER STOP 35013-MZ8-U10 (replaces 35130-MZ5-671)	001	\$64.44
06	SWITCH, TURN SIGNAL 35200-MZ5-671	001	\$102.59
07	SWITCH, FR. LEVER 35330-413-003	001	\$16.64
08	HOLDER 45517-MR1-671	001	\$19.49
09	GRIP ASSY., R. 53145-MM8-000	001	\$30.80
12	GRIP, L. HANDLE 53166-MM8-000	001	\$20.11
13	CAP, GRIP END 53167-MM8-000	002	\$7.09
14	BRACKET, HANDLEBAR 53172-MR1-000	001	\$25.53
15	LEVER, L. HANDLEBAR 53178-KV0-000	001	\$13.96

#	Description	Q'ty	Price
16	BOLT, CABLE ADJ. 53192-268-000	001	\$5.45
17	MIRROR ASSY., R. 88110-MZ5-003	001	\$56.29
18	MIRROR ASSY., L. 88120-MZ5-003	001	\$56.29
19	BOLT, L. 90113-438-000	001	\$5.96
20	NUT, CAP (6MM) 90201-415-000	001	\$1.58
21	NUT, FIXING 90321-MA6-750	001	\$7.91
22	BAND, WIRE HARNESS 90651-MA6-720	004	\$2.78
22	BAND, CABLE (120MM) 90674-WA8-003	004	\$1.80
23	SCREW, PAN (5X20) 93500-05020-0B	001	\$0.67
24	SCREW, PAN (5X22) 93500-05022-0B	001	\$0.70
25	SCREW, PAN (5X25) 93500-05025-0B	001	\$0.63
26	SCREW, PAN (5X32) 93500-05032-0B	001	\$0.91
27	BOLT, SOCKET (6X22) 96600-06022-10 (replaces 96700-06022-10)	002	\$1.20

Handlebar

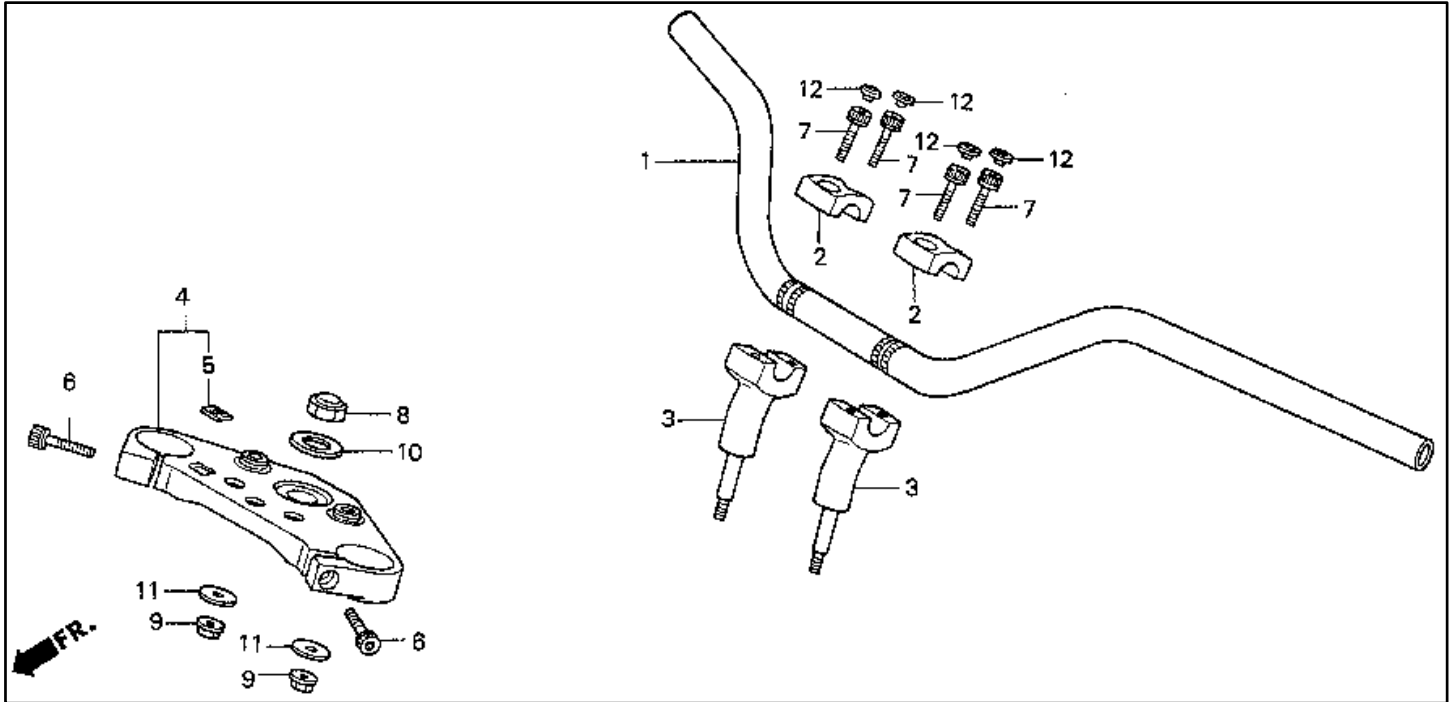

#	Description	Q'ty	Price
01	HANDLEBAR 53101-MZ5-000	001	\$142.97
02	HLD, HANDLE (UPPER) 53131-MM8-000	002	\$14.58
03	HLD, HANDLE (LOWER) 53231-MM8-000	002	\$25.84
04	BRIDGE, FORK TOP 53300-MZ5-000	001	\$217.98
05	EMBLEM, WING MARK 86150-MR1-760	001	\$5.91
06	BOLT, SOCKET (8X30) 90112-KM4-000	002	\$2.98

#	Description	Q'ty	Price
07	BOLT, SOCKET (8X32) 90154-ME9-000	004	\$4.47
08	NUT, STEERING STEM 90304-415-000	001	\$15.02
09	NUT, FLANGE (8MM) 90309-428-731	002	\$2.98
10	WASHER 90503-283-000	001	\$3.51
11	WASHER 90535-KB9-000	002	\$4.67
12	CAP (8MM) 91455-MB0-010	004	\$2.95

Headlight

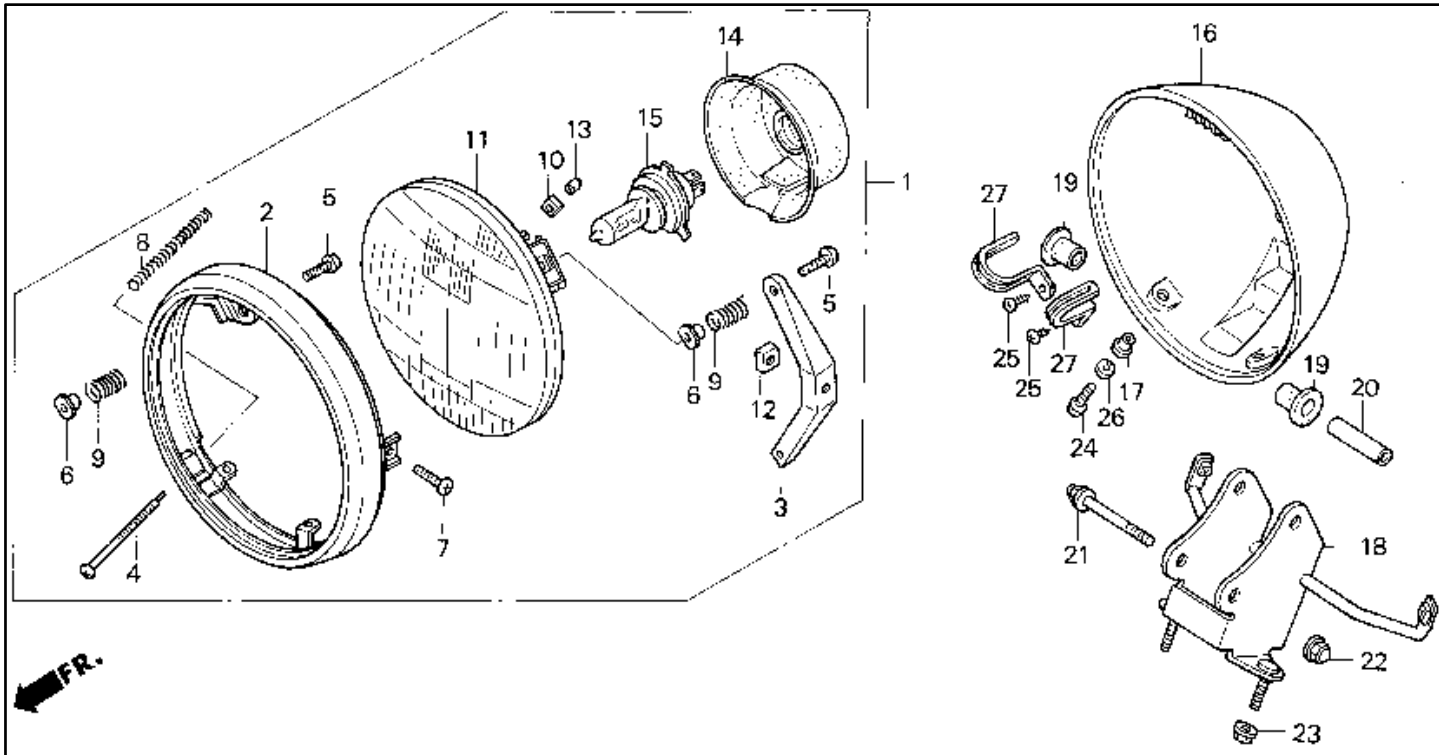

#	Description	Q'ty	Price
01	HDLT (12V 60/55W) 33100-MK7-671	001	\$182.85
02	RIM, HEADLIGHT 33101-MK7-671	001	\$47.61
03	STAY 33102-MK7-671	001	\$8.07
04	SCREW, BEAM ADJ. 33103-MK7-671	002	\$3.22
05	SCREW, SPECIAL 33104-MK7-671	002	\$2.33
06	NUT, SPECIAL 33105-MK7-671	002	\$3.33
07	SCREW, SPECIAL 33106-MK7-671	001	\$2.33
08	SPRING 33107-MK7-671	002	\$2.98
09	SPRING, SETTING 33108-MK7-671	002	\$2.33
10	NUT, BEAM ADJUSTING 33117-415-003	002	\$1.60
11	HEADLIGHT UNIT 33120-MK7-671	001	\$78.44
12	NUT, UNIT HOLDER 33128-471-003	001	\$1.20
13	CVR. ADJUSTING SCREW 33136-111-671	002	\$1.44
14	COVER, RUBBER 33180-MJO-010	001	\$11.67

#	Description	Q'ty	Price
15	BULB (12V60/55W) 34901-MC7-601AH (replaces 34901-MC7-601)	001	\$7.65
16	CASE, HEADLIGHT 61301-MN0-003	001	\$73.70
17	COLLAR 61304-292-000	002	\$2.73
18	STAY, HEADLIGHT 61305-MZ5-000	001	\$49.05
19	RUBBER 61315-MZ5-000	004	\$2.07
20	COLR, HEADLIGHT STAY 61316-MK7-000	002	\$2.33
21	BOLT, CAP (6MM) 90132-MK7-000	002	\$2.25
22	NUT, CAP (6MM) 90201-425-700	002	\$3.33
23	NUT, U (6MM) 90301-MG3-000	002	\$5.40
24	SCREW, PAN (5X16) 93500-05016-0B	002	\$0.68
25	SCREW, TAP (4X10) 93901-34210	002	\$0.47
26	WASHER, SPRING (5MM) 94111-05000	002	\$0.50
27	CLIP (4X90) 94591-49000	002	\$2.38

Mark VF750C (1994-1997)

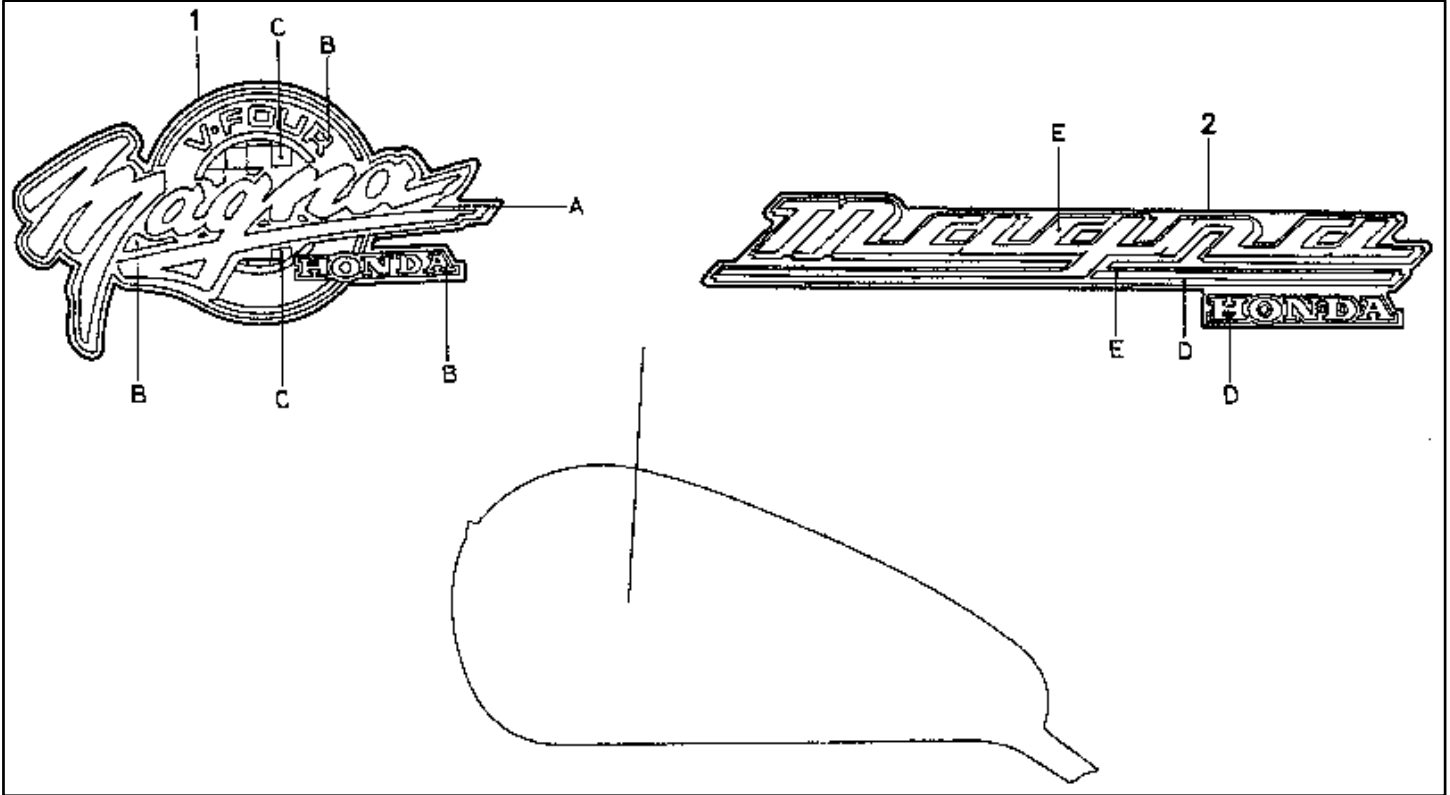

#	Description	Q'ty	Price
01	MARK A (TYPE1) 87121-MZ5-300ZA	002	\$34.98
01	MARK A (TYPE2) 87121-MZ5-300ZB	002	\$34.98

#	Description	Q'ty	Price
01	MARK A (TYPE3) 87121-MZ5-300ZC	002	\$34.98

Mark VF750C (1998-2003)

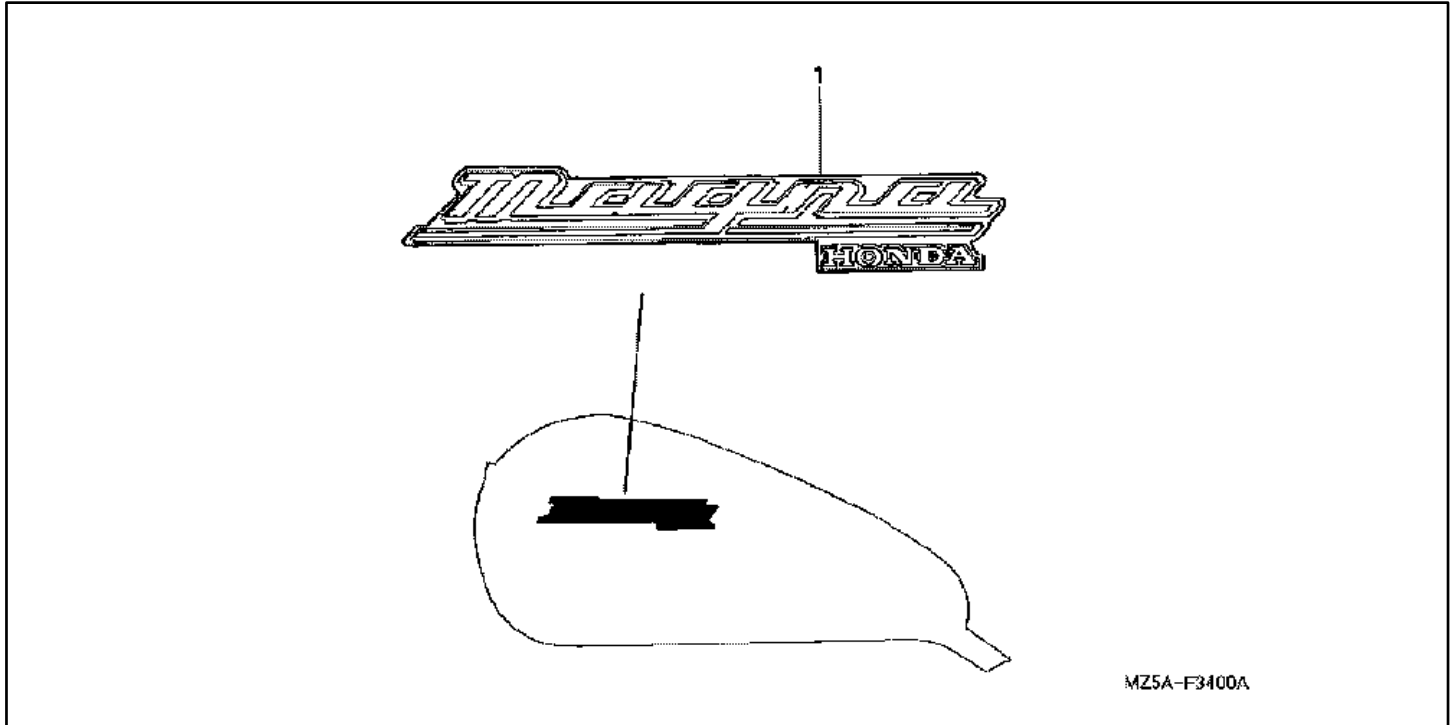

#	Description	Q'ty	Price
01	MARK (TYPE5) 87121-MZ5-A00ZA	002	\$24.02
01	MARK (TYPE6) 87121-MZ5-A40ZA	002	\$20.96

#	Description	Q'ty	Price
01	MARK (TYPE7) 87121-MZ5-M10ZA	002	\$22.60

Mark VF750CD (1996-1997)

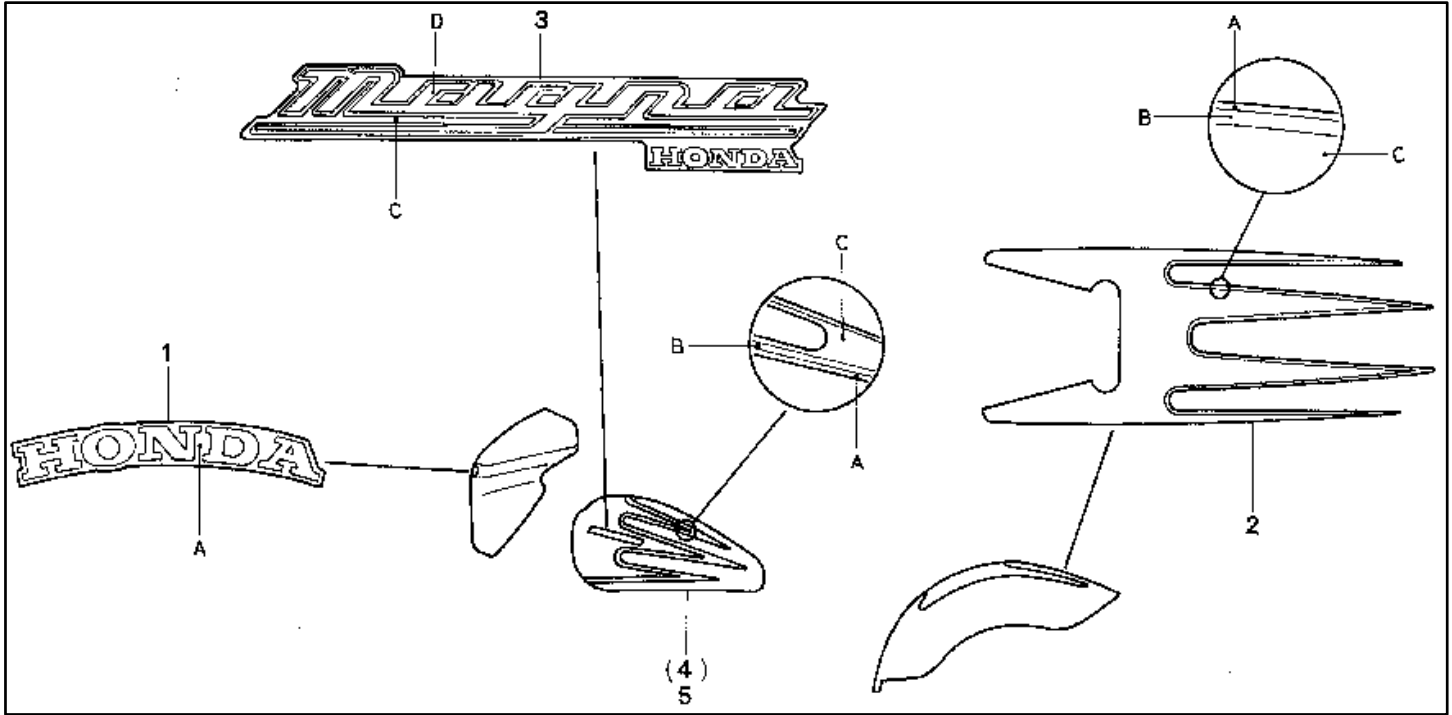

#	Description	Q'ty	Price
01	MARK (TYPE10) 64221-MZ5-870ZA	001	\$20.29
01	MARK (TYPE9) 64221-MZ5-870ZB	001	\$20.29
02	STRIPE, RR. (TYPE1) 80111-MZ5-950ZA	001	
02	STRIPE, RR. (TYPE2) 80111-MZ5-950ZB	001	\$96.40
02	STRIPE, RR. (TYPE3) 80111-MZ5-A10ZA	001	\$79.53
02	STRIPE, RR. (TYPE4) 80111-MZ5-A10ZB	001	\$79.53
03	MARK (TYPE1) 87121-MZ5-950ZA	002	\$26.47
03	MARK (TYPE2) 87121-MZ5-950ZB	002	\$26.47
03	MARK (TYPE3) 87121-MZ5-A10ZA	002	\$23.38

#	Description	Q'ty	Price
03	MARK (TYPE4) 87121-MZ5-A10ZB	002	\$21.73
04	STRIPE, R. (TYPE1) 87123-MZ5-950ZA	001	\$93.75
04	STRIPE, R. (TYPE2) 87123-MZ5-950ZB	001	\$93.75
04	STRIPE, R. (TYPE3) 87123-MZ5-A10ZA	001	\$82.16
04	STRIPE, R. (TYPE4) 87123-MZ5-A10ZB	001	\$76.33
05	STRIPE, L. (TYPE1) 87124-MZ5-950ZA	001	\$93.75
05	STRIPE, L. (TYPE2) 87124-MZ5-950ZB	001	\$93.75
05	STRIPE, L. (TYPE3) 87124-MZ5-A10ZA	001	\$82.16
05	STRIPE, L. (TYPE4) 87124-MZ5-A10ZB	001	\$76.33

Mark VF750C2 (1998-2000)

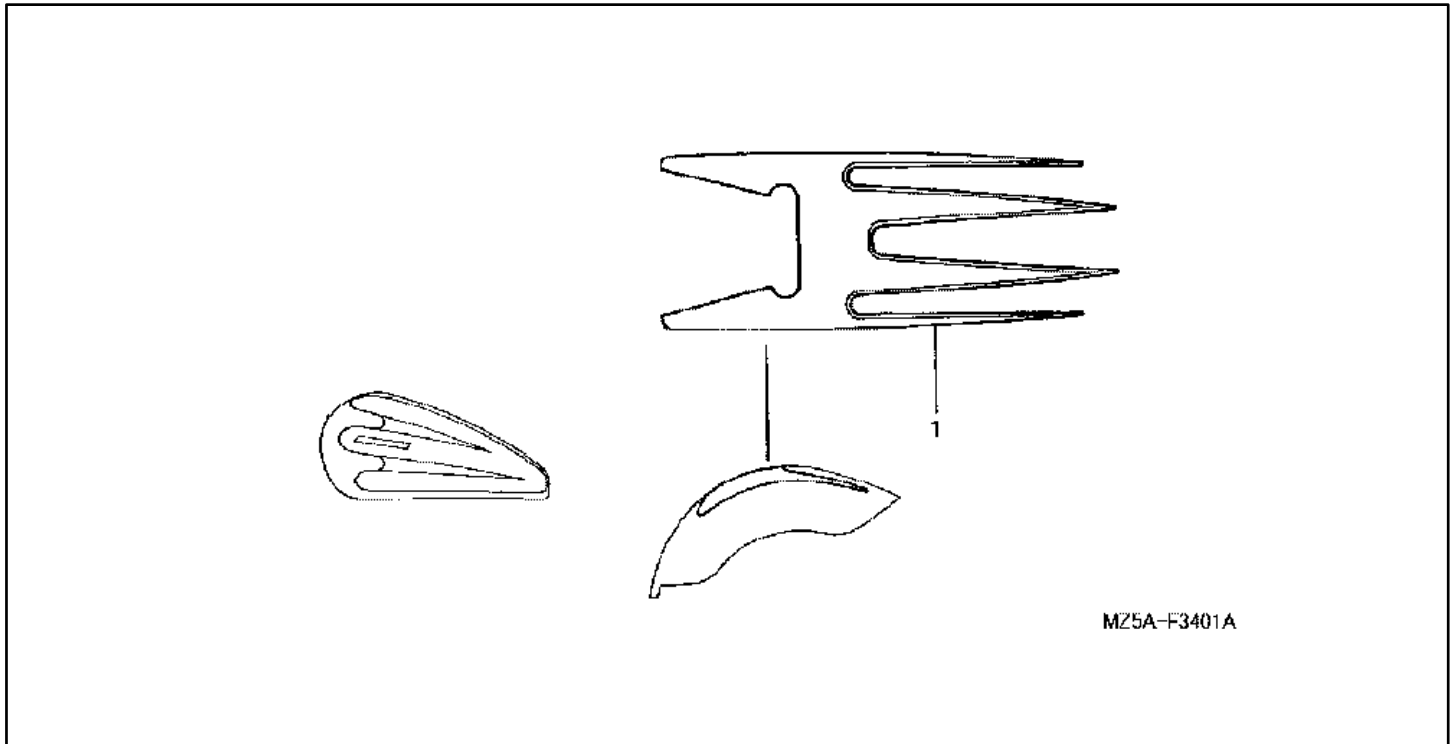

#	Description	Q'ty	Price
98	STRIPE, RR. (TYPE5) 80111-MZ5-A30ZA	001	\$70.87
98	STRIPE, RR. (TYPE6) 80111-MZ5-A30ZB	001	

#	Description	Q'ty	Price
99	STRIPE, RR. (TYPE7) 80111-MZ5-A50ZA	001	\$71.89
00	STRIPE, RR. (TYPE8) 80111-MZ5-A70ZA	001	\$73.13

Muffler

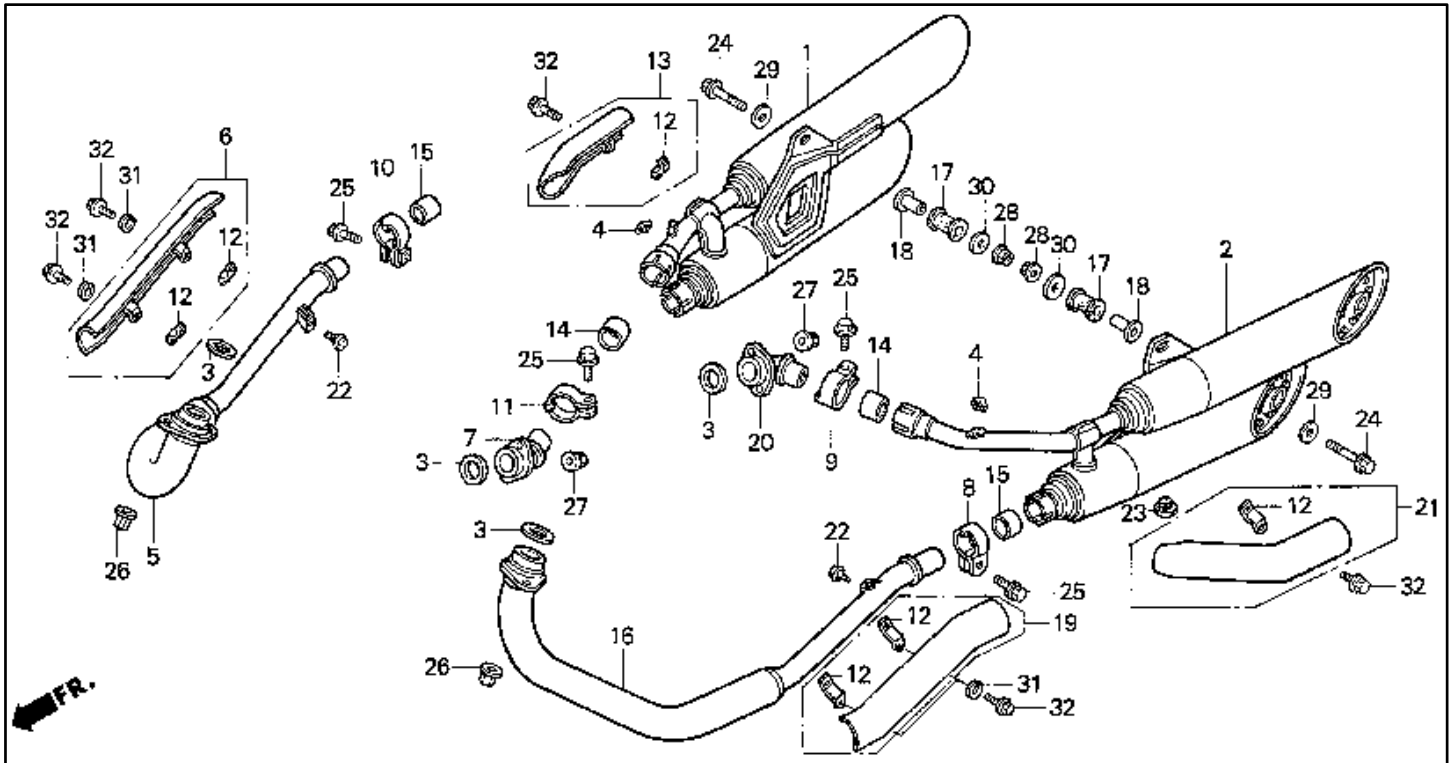

#	Description	Q'ty	Price
01	MUFFLER, R. EX. 18100-MZ5-003	001	\$699.35
02	MUFFLER, L. EX. 18200-MZ5-003	001	\$699.35
03	GASKET, EX. PIPE 18291-MN4-920	004	\$4.22
04	RUBBER 18293-ME9-000	002	\$1.95
05	PIPE, R. FR. EX. 18320-MZ5-981 (replaces 18320-MZ5-003)	001	\$114.12
06	CVR, R. FR. EX. PIPE 18340-MZ5-003	001	\$105.55
07	JOINT, R. RR. CYL HD 18350-MZ5-003	001	\$87.87
08	BAND, R. EX. PIPE 18373-ML4-003	001	\$21.73
09	BAND, EX. PIPE 18373-KAB-000 (replaces 18373-MN1-670)	001	\$15.44
10	BAND, L. EX. PIPE 18374-ML4-003	001	\$12.42
11	BAND, L. EX. PIPE 18374-MN1-670	001	\$10.95
12	BAND, EX. PIPE COVER 18376-MR1-000	006	\$6.45
13	CVR, R. RR. EX. PIPE 18380-MZ5-003	001	\$96.68
14	GASKET, MUFFLER 18391-MB0-891	002	\$13.58
15	GASKET, MUFFLER 18391-ML8-000	002	\$13.73
16	PIPE, L. FR. EX. 18420-MZ5-981 (replaces 18420-MZ5-003)	001	\$114.12

#	Description	Q'ty	Price
17	RUB, MUFFLER SETTING 18421-MB0-000	002	\$4.98
18	COLLAR 18422-MB0-000	002	\$5.22
19	CVR, L. FR. EX. PIPE 18440-MZ5-003	001	\$106.57
20	JOINT, L. RR. CYL HD 18450-MZ5-003	001	\$87.87
21	CVR, L. RR. EX. PIPE 18480-MZ5-003	001	\$99.99
22	RUBBER, STOPPER 50501-KT7-810	002	\$3.09
23	RUBBER, BATTERY BOX 83618-GF0-751	001	\$3.05
24	BOLT (8X50) 90109-MZ5-000	002	\$5.11
25	BOLT, FLANGE (8X35) 90161-ML7-000	004	\$2.84
26	NUT, SPECIAL (6MM) 90304-HB3-771	004	\$4.76
27	NUT, FLANGE (6MM) 94050-06000	004	\$0.72
28	NUT, FLANGE (8MM) 94050-08070	002	\$0.33
29	WASHER, PLAIN (8MM) 94103-08000	002	\$0.29
30	WASHER, PLAIN (8MM) 94103-08700	002	\$0.45
31	WASHER, SPRING (6MM) 94111-06800	004	\$0.50
32	BOLT, FLANGE (6X20) 95701-06020-00	006	\$0.60

Oil Pump

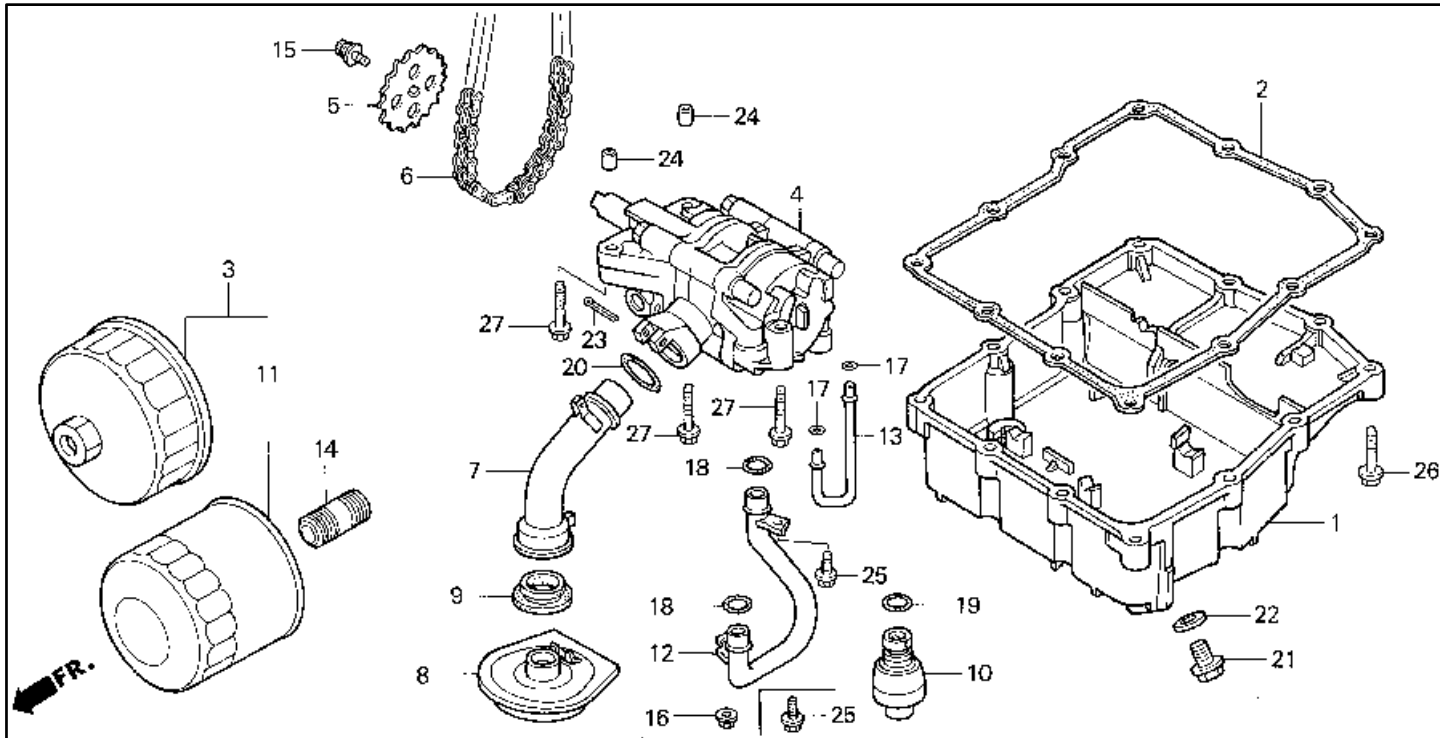

#	Description	Q'ty	Price
01	PAN, OIL 11211-MZ5-000	001	\$151.28
02	GASKET, OIL PAN 11315-MY7-000	001	\$10.31
03	FILTER SET, OIL 15010-MCE-H51 (replaces 15010-MW0-000)	001	\$21.67
04	PUMP ASSY., OIL 15100-MZ5-003	001	Call For Price
05	SPROCKET 15134-MZ5-000	001	\$27.53
06	CHAIN, OIL PUMP 15140-ML7-003	001	\$29.55
07	PIPE, OIL STRAINER 15151-ML7-000	001	\$26.24
08	STRAINER, OIL 15153-ML7-690	001	\$14.87
09	GASKET, OIL STRAINER 15154-ML7-000	001	\$5.20
10	VALVE ASSY., RELIEF 15220-MZ5-000	001	\$26.78
11	FILTER, OIL 15410-MFJ-D01 (replaces 15410-MM9-013)	001	\$11.98
12	PIPE A, OIL 15511-MZ5-000	001	\$38.51
13	PIPE B, OIL 15512-ML7-000	001	\$14.04
14	BOSS, OIL FILTER 90019-MB0-000	001	\$6.80

#	Description	Q'ty	Price
15	BOLT-WASHER (6X12) 90021-MM5-000	001	\$4.00
16	NUT, U (6MM) 90301-473-003	001	\$2.15
17	O-RING (6X2) 91307-ML7-004	002	\$1.87
18	O-RING (14.6X3.7) 91309-MB0-003	002	\$2.93
19	O-RING (14.8X2.2) 91313-MG7-004 (replaces 91313-MB0-003)	001	\$2.35
20	O-RING (21.2X2.4) 91331-PC9-003	001	\$1.95
21	BOLT, DRAIN (12MM) 92800-12000	001	\$1.73
22	WASHER, DRAIN (12MM) 94109-12000	001	\$0.50
23	PIN, COTTER (2.0X35) 94201-20350 (replaces 94201-20250, 94201-20280, 94201-20320)	001	\$0.65
24	PIN, DOWEL (8X14) 94301-08140	002	\$1.00
25	BOLT, FLANGE (6X14) 95701-06014-00	002	\$0.63
26	BOLT, FLANGE (6X28) 95701-06028-00	012	\$0.85
27	BOLT, FLANGE (6X40) 95701-06040-00	003	\$0.85

Pedal

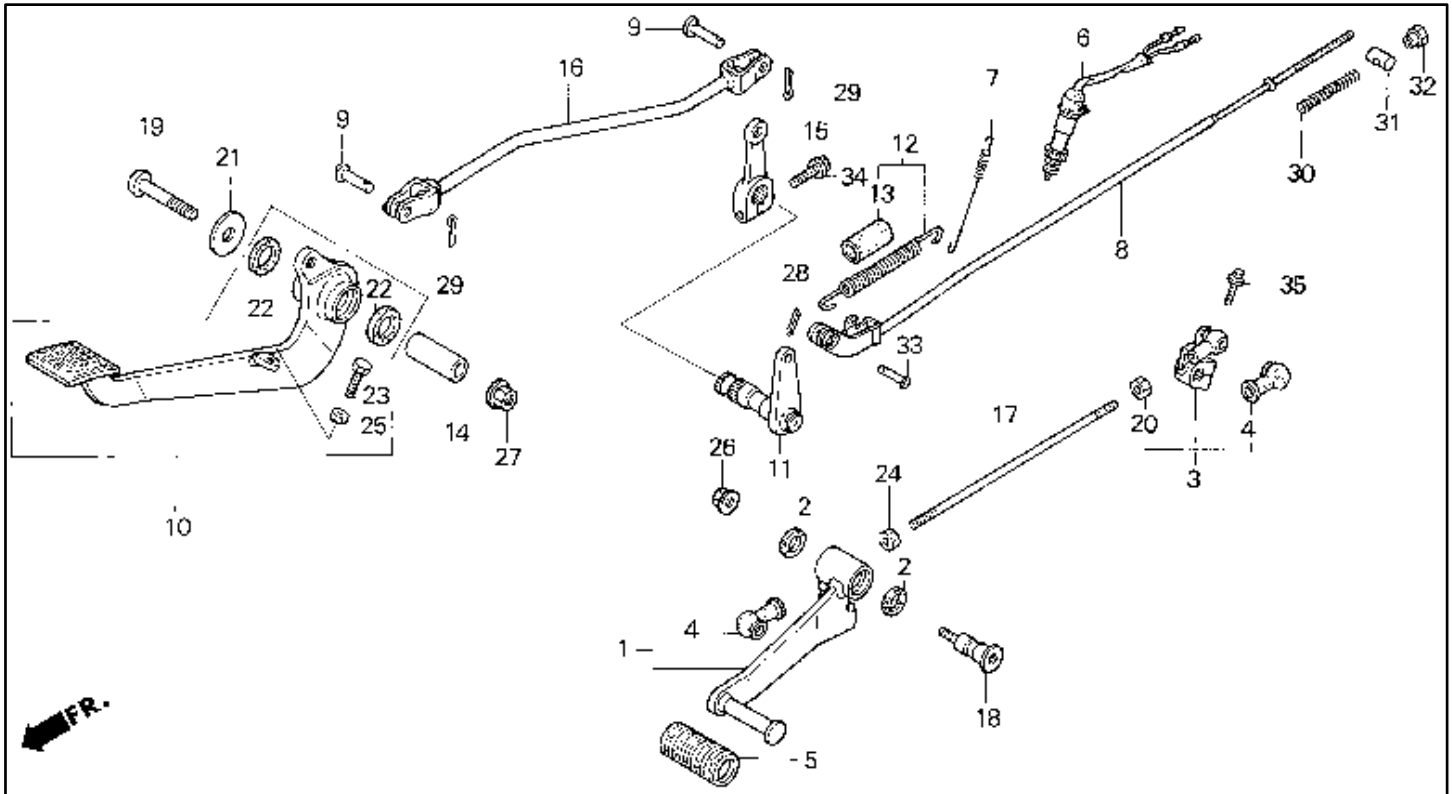

#	Description	Q'ty	Price
01	PEDAL, GEARSHIFT 24705-MZ5-700 (replaces 24705-MZ5-000)	001	\$54.18
02	RUBBER, DUST SEAL 24706-MK3-770	002	\$3.51
03	ARM, GEARSHIFT 24706-MZ5-000	001	\$35.67
04	COVER, DUST 24724-422-000	002	\$5.67
05	RUB, GEARSHIFT PEDAL 24781-KR3-770	001	\$2.65
06	SWITCH, RR. STOP 35350-MZ5-003	001	\$12.13
07	SPRING, STOP SWITCH 35357-MF8-000	001	\$3.71
08	ROD, RR. BRAKE 43451-MZ5-000	001	\$24.84
09	PIN 43456-MK7-000	002	\$6.45
10	PEDAL, BRAKE 46500-MZ5-000	001	\$62.88
11	ARM, RR. 46501-MZ5-000	001	\$29.73
12	SPRING SET 46513-KY7-000	001	\$7.96
13	TUBE 46515-KY7-000	001	\$3.86
14	COLLAR, RR. 46515-MM8-000	001	\$8.89
15	ARM, RR. 46530-MZ5-000	001	\$10.51
16	ROD, RR. 46540-MZ5-000	001	\$44.51
17	BOLT, TIE ROD 90065-MN4-000	001	\$3.89
18	BOLT, CHANGE PIVOT 90115-KAF-000	001	\$14.96

#	Description	Q'ty	Price
19	BOLT, SOCKET (10X52) 90153-MW0-000	001	\$5.04
20	NUT 90201-700-000	001	\$0.55
21	WASHER (10.3MM) 90527-230-000	001	\$1.44
22	DUST SEAL (17X23X3) 91206-968-003	002	\$2.98
23	BOLT, HEX. (6X18) 92101-06018-0A	001	\$0.62
24	NUT, HEX. (6MM) 94001-06020-0S	001	\$0.63
25	NUT, HEX. (6MM) 94002-06000-0S	001	\$1.60
26	NUT, FLANGE (8MM) 94050-08000	001	\$0.67
27	NUT, FLANGE (10MM) 94050-10000	001	\$0.93
28	PIN, SPLIT (2.0X12) 94201-20120	001	\$0.47
29	PIN, SPLIT (2.0X15) 94201-20150	002	\$0.35
30	SPRING A, BRAKE ROD 95014-73100	001	\$0.53
31	JOINT, BRAKE ARM 95015-32001	001	\$0.49
32	NUT B 95015-42000	001	\$1.40
33	PIN, JOINT 95015-53000	001	\$2.42
34	BOLT, FLANGE (8X25) 95701-08025-00	001	\$1.00
35	BOLT, FLANGE (6X20) 96001-06020-00	001	\$0.83

Pulse Generator

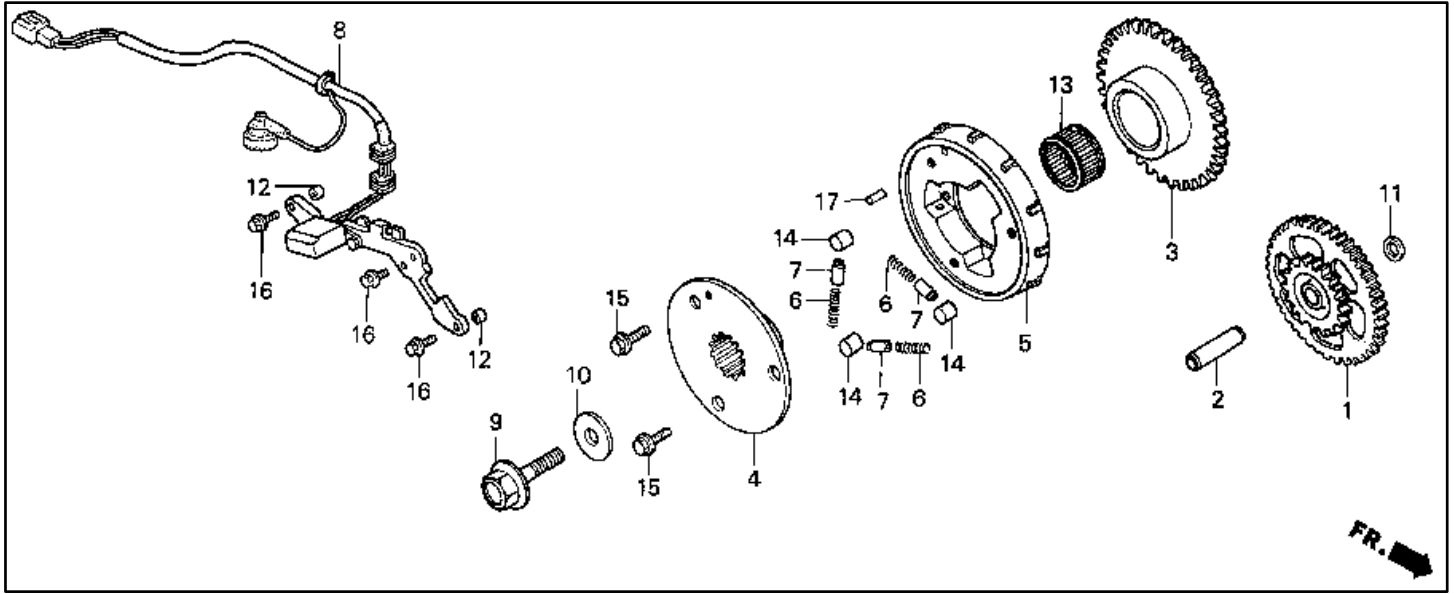

#	Description	Q'ty	Price
01	GEAR (21T/83T) 28101-ML7-920	001	\$76.41
02	PIN (10X36.5) 28102-ML7-000	001	\$6.56
03	GEAR (48T) 28110-MB0-010	001	\$109.19
04	FLANGE 28115-MZ5-000	001	\$73.01
05	CLUTCH, STARTER 28120-MZ5-000	001	\$152.21
06	SPRING 28125-MT4-000	003	\$1.42
07	CAP 28126-415-000	003	\$12.98
08	GEN, IGNITION PULSE 30300-MZ5-003 (replaces 30300-MZ5-000)	001	\$98.46
09	BOLT, FLANGE (12X45) 90023-MA6-000	001	\$7.96

#	Description	Q'ty	Price
10	WASHER (12X30X4.5) 90401-KK9-960	001	\$7.91
11	WASHER (18X10.2) 90405-ML7-000	001	\$2.84
12	PIN, DOWEL (8X8) 90702-MB0-000	002	\$2.73
13	BEARING (30X35X17) 91022-MB0-004 (replaces 91022-MB0-003)	001	\$26.51
14	ROLLER (15X13) 91101-516-000	003	\$4.53
15	BOLT, FLANGE (8X14) 95701-08014-08	003	\$0.78
16	BOLT, FLANGE (6X25) 96001-06025-00	003	\$0.93
17	ROLLER (6X15) 96220-60150	001	\$0.62

Radiator

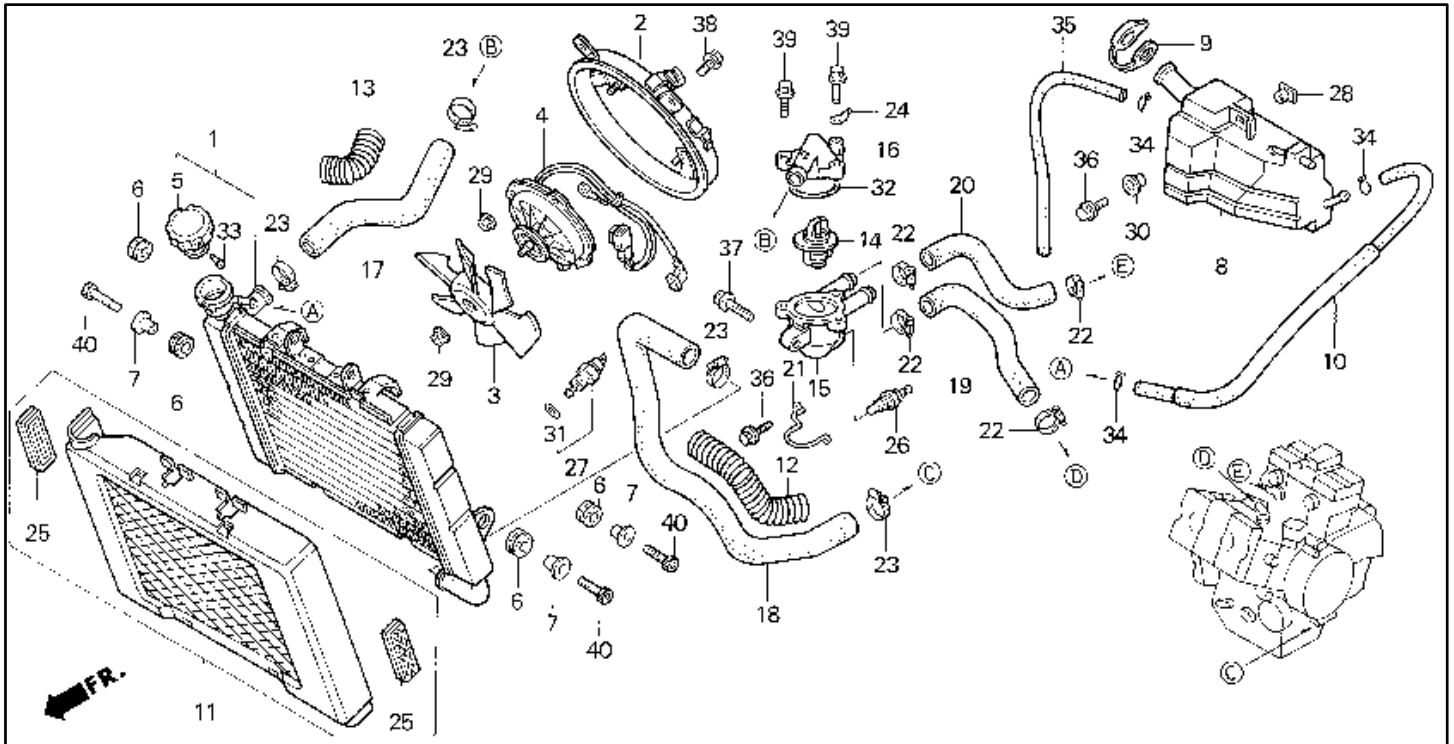

#	Description	Q'ty	Price
01	RADIATOR COMP 19010-MZ5-P00 (replaces 19010-MZ5-671)	001	\$612.40
02	SHROUD 19015-MZ5-003	001	\$57.00
03	FAN, COOLING 19025-MN4-003	001	\$42.05
04	MOTOR ASSY., FAN 19030-MZ5-003	001	\$240.71
05	CAP, RADIATOR 19045-MY3-671	001	\$30.69
06	RUBBER 19051-KA3-830	004	\$2.67
07	COLLAR 19052-MN8-000	003	\$2.04
08	TANK, RESERVE 19101-MZ5-000	001	\$30.89
09	CAP, RESERVE TANK 19104-MB0-700	001	\$9.24
10	TUBE, RESERVE TANK 19106-MZ5-000	001	\$25.16
11	GRILLE, RADIATOR 19112-MZ5-670 (replaces 19110-MZ5-000)	001	\$70.69
12	PROTR, RADIATOR HOSE 19120-MZ5-910 (replaces 19120-MZ5-000)	001	\$36.55
13	PROTR, RADIATOR HOSE 19121-MZ5-000	001	\$10.15
14	THERMOSTAT ASSY. 19300-ML7-003	001	\$33.89
15	COVER, THERMOSTAT 19311-MZ5-000	001	\$60.67
16	COVER, THERMOSTAT 19315-MV9-670	001	\$48.56
17	HOSE, RADIATOR 19500-MZ5-000	001	\$20.91
18	HOSE, RADIATOR 19501-MZ5-000	001	\$29.96
19	HOSE, FR. 19502-MZ5-000	001	\$13.64
20	HOSE, RR. HEAD WATER 19503-MZ5-000	001	\$12.42
21	GUIDE, WATER HOSE 19504-MZ5-000	001	\$7.71

#	Description	Q'ty	Price
22	CLAMP B, WATER HOSE 19506-KS6-700	004	\$6.13
23	CLAMP, HOSE (30-37) 19516-GAG-003	004	\$10.95
24	CONNECTOR, GROUND 32152-MB3-000	001	\$1.33
25	REFLECTOR, FR. 33740-KR3-671	002	\$22.31
26	SENDING UNIT 37750-PC1-004	001	\$43.83
27	SWITCH, THERMOSTAT 37760-MT2-003	001	\$49.49
28	NUT, SPECIAL (6X7) 61304-958-003 (replaces 90301-471-000)	001	\$2.64
29	NUT, SERRATE (5MM) 90315-MK3-003	004	\$1.67
30	WASHER, FR. 90556-MB4-000	001	\$1.91
31	O-RING (13.5X1.4) 91307-PH7-660 (replaces 91307-611-000)	001	\$1.72
32	O-RING (47.5X2) 91311-KE8-000	001	\$1.64
32	O-RING (45.5X2.5) 91373-733-003	001	\$3.20
33	SCREW, TAPPING (3X8) 93901-22180	001	\$0.47
34	NUT, FLANGE (6MM) 94050-06000	001	\$0.72
34	CLIP, TUBE (B10) 95002-02100	003	\$0.90
35	BULK HOSE (5.5X3000) 95005-55003-20M	001	\$18.33
36	BOLT, FLANGE (6X12) 95701-06012-00	002	\$0.72
37	BOLT, FLANGE (6X22) 95701-06022-00	001	\$0.72
38	BOLT, FLANGE (6X10) 96001-06010-00	003	\$0.85
39	BOLT, FLANGE (6X22) 96001-06022-00	003	\$0.91
40	BOLT, SOCKET (6X25) 96600-06025-07	003	\$0.88

Rear Brake Panel

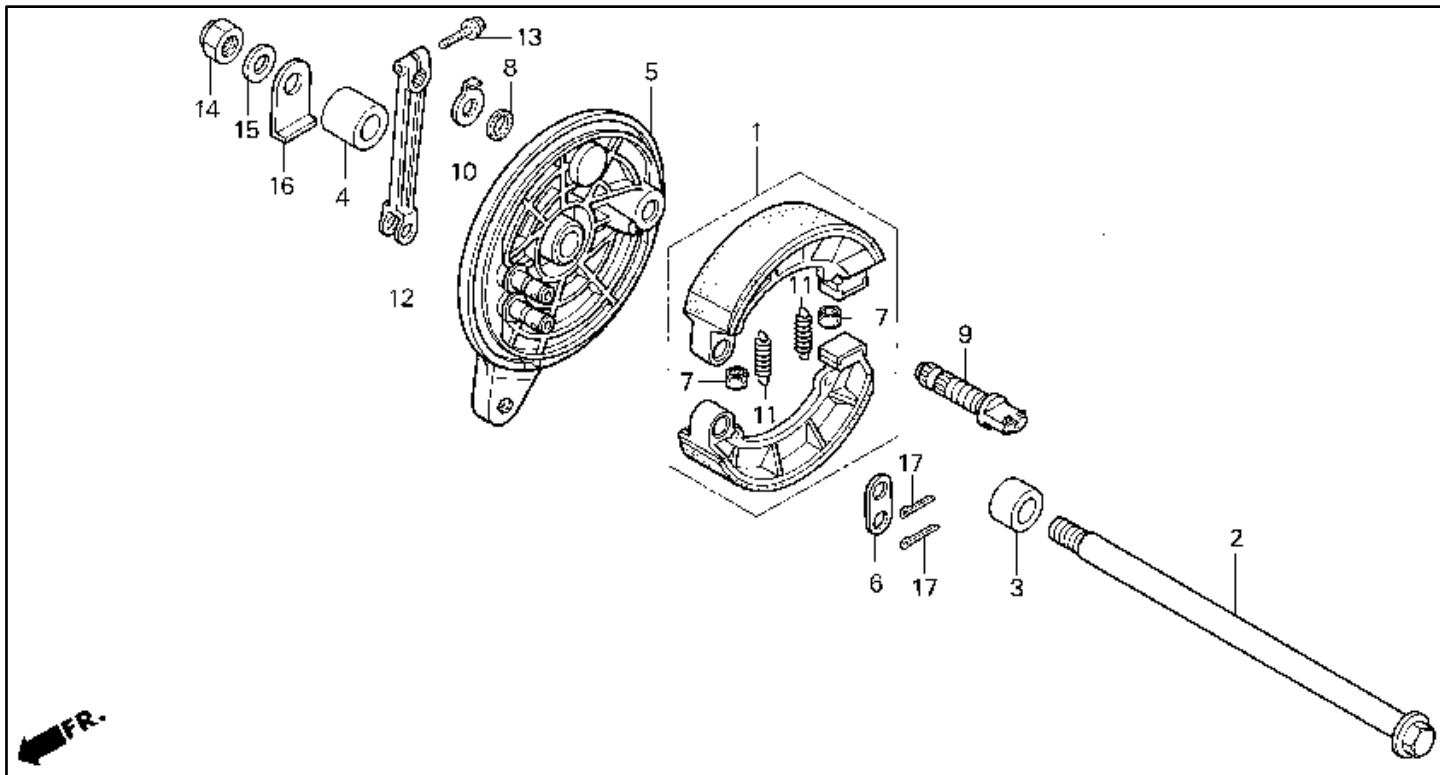

#	Description	Q'ty	Price
01	SHOE KIT, BRAKE 06430-MZ5-003	001	\$40.27
02	AXLE, RR. WHEEL 42301-MZ5-003	001	\$47.41
03	COLR, RR. WHEEL SIDE 42311-MZ1-610 (replaces 42311-MZ1-000)	001	\$16.18
04	COLLAR, RR. 42313-MZ5-000	001	\$15.69
05	PANEL, RR. 43100-MJ1-832	001	\$182.85
06	WASHER, ANCHOR PIN 43102-319-000	001	\$4.96
07	TUBE 43124-MZ5-000	002	\$5.48
08	DUST SEAL, BRAKE CAM 43134-300-000	001	\$1.62
09	CAM, RR. BRAKE 43141-MB0-010 (replaces 43141-MB0-000)	001	\$28.64

#	Description	Q'ty	Price
10	INDICATOR, RR. BRAKE 43145-ME5-000	001	\$4.58
11	SPRING, RR. 43151-346-000	002	\$4.64
12	ARM, RR. BRAKE 43410-MZ5-000	001	\$26.58
13	BOLT, FLANGE (8X25) 90107-MZ5-000	001	\$3.65
14	NUT, U (18MM) 90305-KZ4-891 (replaces 90305-KZ4-890)	001	\$11.42
15	WASHER (18X32X2) 90401-KZ4-890	001	\$3.58
16	WASHER, RR. AXLE 90559-MJ0-630	001	\$10.16
17	PIN, COTTER (2.5MM) 94201-25300 (replaces 94201-25200, 94201-25250)	002	\$0.53

Rear Cylinder Head

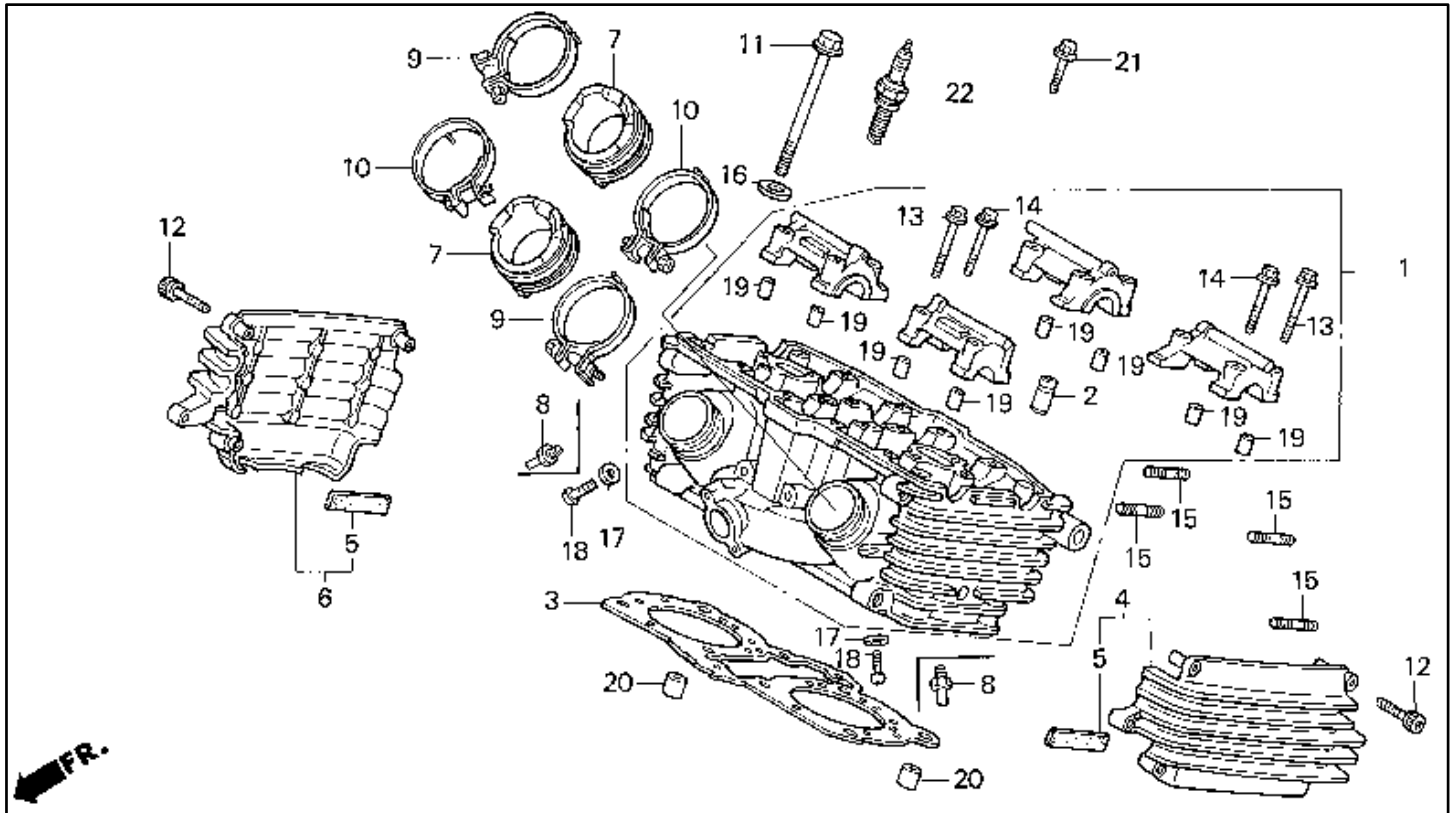

#	Description	Q'ty	Price
01	CYLINDER HEAD, RR. 12020-MZ5-315	001	\$834.03
01	CYLINDER HEAD, RR. 12020-MZ5-316	001	\$834.03
02	GUIDE, VALVE (OS) 12204-MT4-305	008	\$16.15
03	GASKET, CYL HD 12251-MT4-014 (replaces 12251-MT4-004)	001	\$46.67
04	FIN A, CYLINDER HEAD 12350-MZ5-000	001	\$113.93
05	RUBBER, SEAT 12352-MZ5-300	002	\$2.44
06	FIN B, CYLINDER HEAD 12360-MZ5-000	001	\$73.62
07	INSULATOR, CARB 16211-MZ5-000	002	\$38.78
08	JOINT, BOOSTER 16214-MB0-000	002	\$3.51
09	BAND A, INSULATOR 16219-MM4-000	002	\$8.07
10	BAND B, INSULATOR 16220-MM4-000	002	\$8.07
11	BOLT, FLANGE (9X93) 90007-ML7-920	008	\$7.85

#	Description	Q'ty	Price
12	BOLT, SOCKET (6X28) 90012-MZ5-000	006	\$1.60
13	BOLT, FLG (6X45.5) 90017-MA6-000	008	\$2.62
14	BOLT, FLG (6X39.5) 90019-MA6-000	008	\$2.25
15	BOLT, STUD (6X22) 90036-MZ5-000	004	\$4.29
16	WASHER (9MM) 90445-MM4-000	008	\$2.82
17	WASHER (5MM) 90452-323-000	002	\$0.85
18	SCREW, PAN (5X8) 93500-05008-0A	002	\$0.45
19	PIN, DOWEL (8X14) 94301-08140	008	\$1.00
20	PIN, DOWEL (12X20) 94301-12200	002	\$1.17
21	BOLT, FLANGE (6X30) 95701-06030-00	002	\$0.83
22	SPARK PLUG (CR9EH9) 98059-59916 (replaces 98059-58926, 98059-59910)	002	\$8.14

Rear Fender

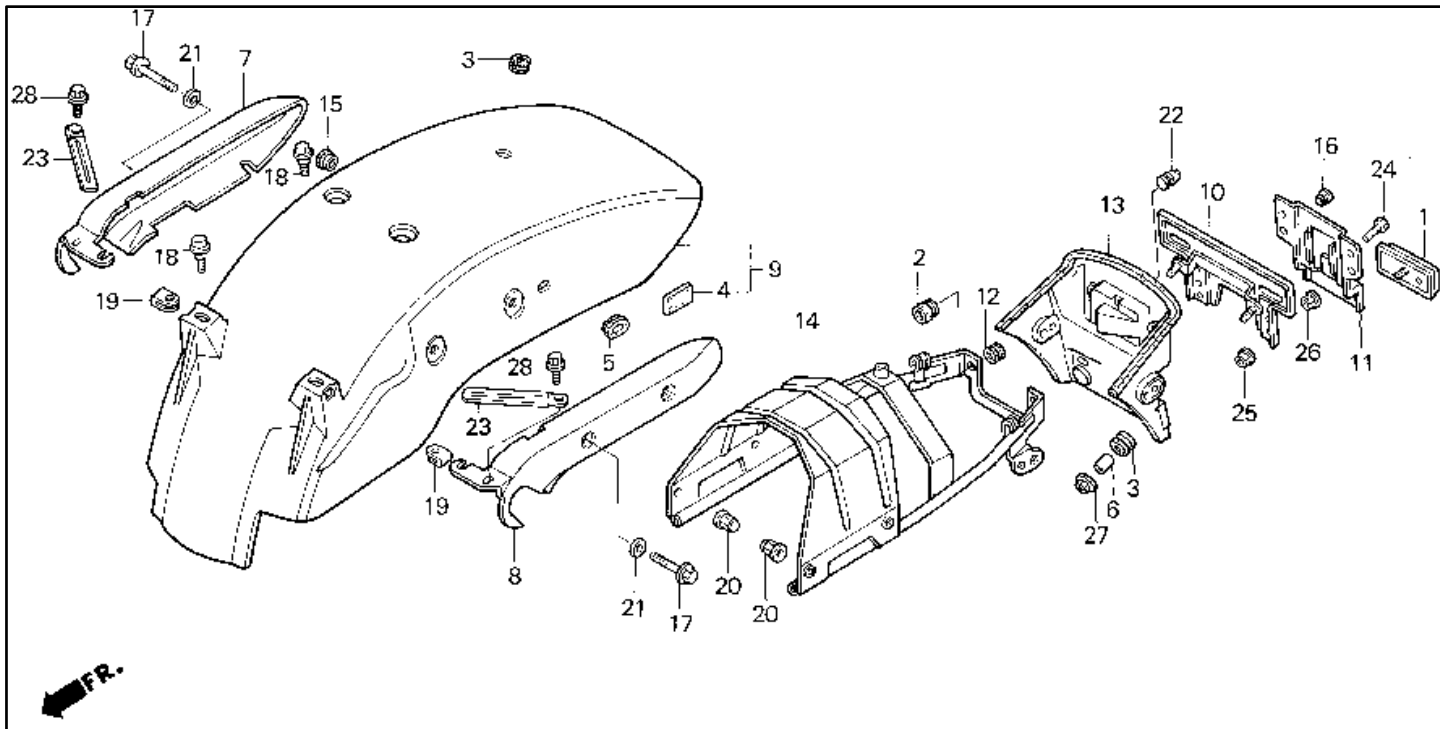

#	Description	Q'ty	Price
01	REFLECTOR, REFLEX 33741-MS6-921	001	\$10.55
02	RUB, METER CUSHION 37215-MA6-008	002	\$2.33
03	GROMMET, ENG HGR 50370-HA2-770	003	\$1.51
04	RUBBER, BATTERY 50383-GB6-300	002	\$3.24
05	GROM, SPEAKER PANEL 64266-MG9-770	001	\$2.45
06	COLLAR, ROTO-STOP 75133-960-000	002	\$2.58
07	GRAB RAIL, R. 77330-MZ5-000	001	\$105.00
08	GRAB RAIL, L. 77340-MZ5-000	001	\$105.00
09	FENDER B, REAR 80100-MZ5-000YB (replaces 80100-MZ5-000ZC)	001	\$164.39
09	FENDER B *Y124P* 80100-MZ5-000ZD	001	\$180.00
09	FENDER B, RR. *R201* 80100-MZ5-000ZE	001	\$154.24
10	BRKT, NUMBER PLATE 80101-MZ5-670	001	\$40.85
11	STAY, RR. REFLECTOR 80102-MM8-010	001	\$17.82
12	GROM, ENGINE COVER 80103-GJ5-000	002	\$1.55
13	FENDER A, RR. 80105-MZ5-000	001	\$66.36

#	Description	Q'ty	Price
14	SUB-FRAME, RR. 80125-MZ5-000	001	\$149.92
15	GROMMET, SIDE COVER 83601-MN5-000	001	\$2.25
16	RUBBER 84702-MF2-670	002	\$3.11
17	BOLT (8X56) 90064-KK3-830	004	\$3.55
18	BOLT 90215-ML0-000	002	\$1.60
19	NUT 90305-SH3-000	002	\$3.65
20	NUT, CAP (8MM) 90443-107-000	004	\$2.30
21	WASHER, PLAIN (8MM) 90518-921-000	004	\$1.12
22	PLUG, CONE TYPE 90899-422-610	003	\$1.45
23	CLIP, WIRE 91406-166-000	002	\$2.93
24	BOLT, HEX. (6X10) 92101-06010-0G	002	\$0.67
25	NUT, HEX. (6MM) 94002-06070-0S	002	\$0.55
26	NUT, FLANGE (5MM) 94050-05000	001	\$0.60
27	NUT, FLANGE (6MM) 94050-06070	002	\$0.73
28	BOLT, FLANGE (6X12) 95701-06012-00	002	\$0.72

Rear Shock Absorber

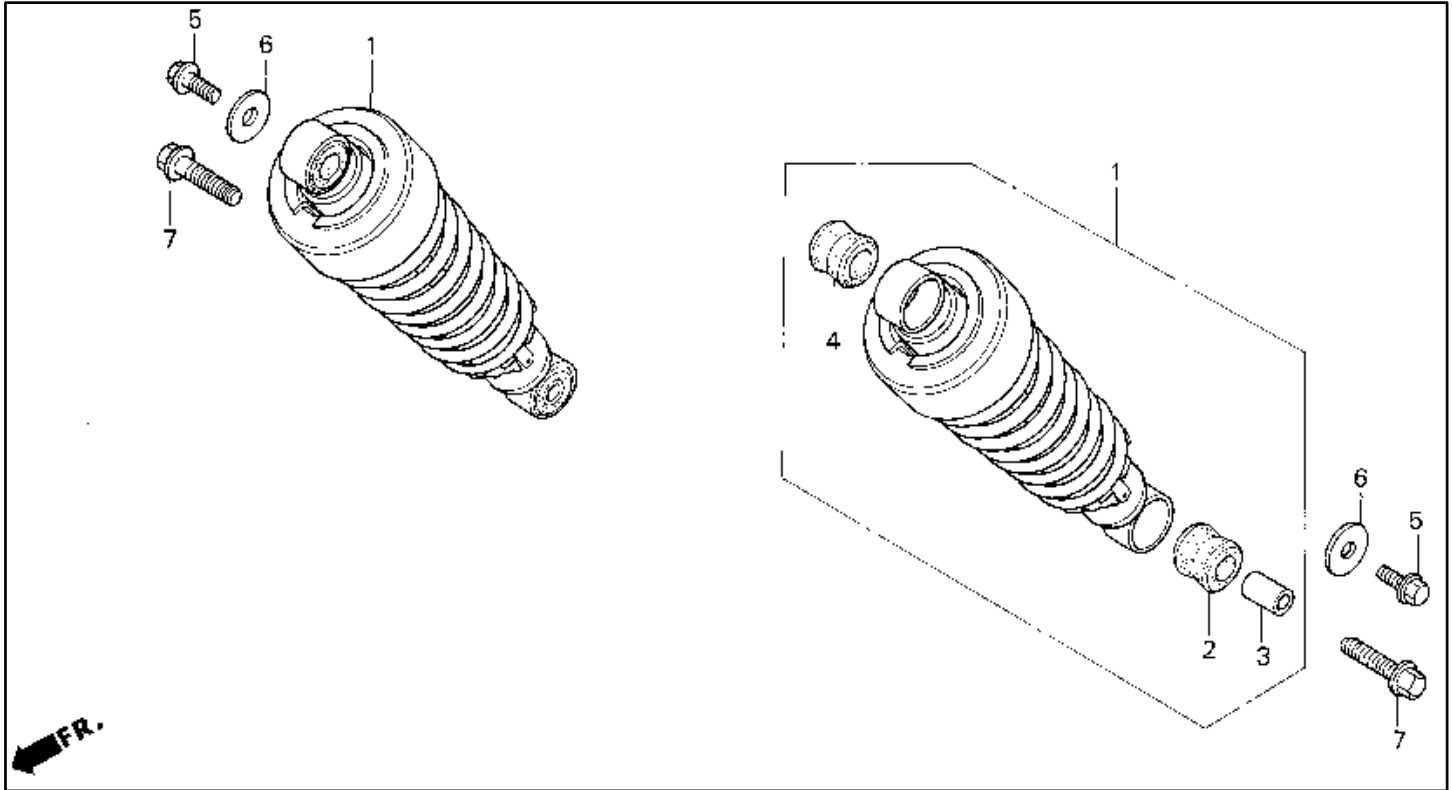

#	Description	Q'ty	Price
01	SHOCK ABSORBER, RR. 52400-MZ5-672 (replaces 52400-MZ5-671)	002	\$306.24
02	BUSH, RR. SHOCK 52485-KR3-003	002	\$3.76
03	COLLAR, RUBBER BUSH 52486-GA7-003	002	\$2.91
04	BUSH, RUBBER (UPPER) 52489-GS3-003	002	\$3.58

#	Description	Q'ty	Price
05	BOLT, FLANGE (8X16) 90106-MB2-000	002	\$3.18
06	WASHER, PLAIN 90501-MZ5-000	002	\$1.91
07	BOLT, FLANGE (10X35) 95817-10035-00 (replaces 95801-10035-00)	002	\$1.23

Rear Wheel

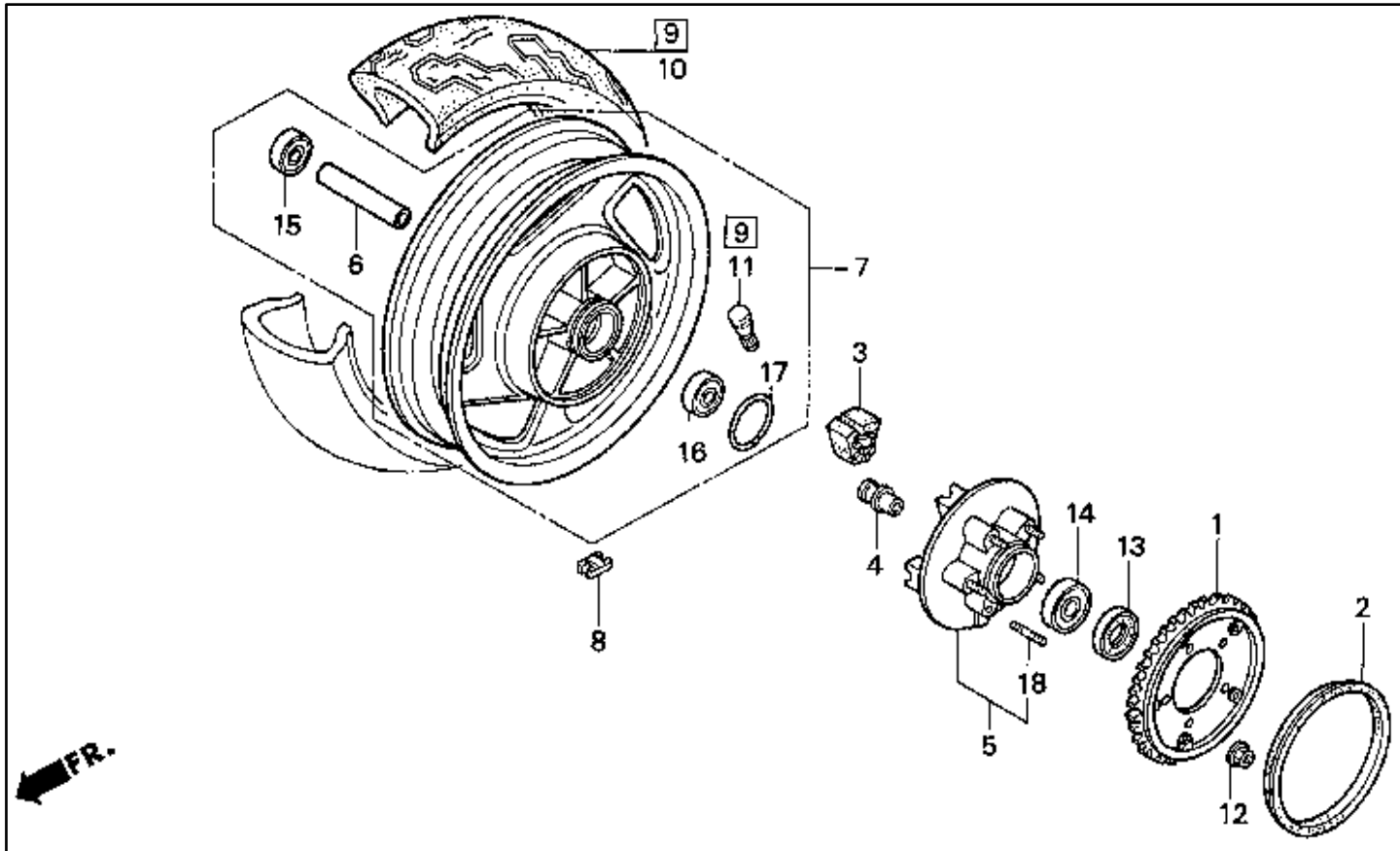

#	Description	Q'ty	Price
01	SPROCKET (40T) 41200-MZ5-770 (replaces 41200-MA3-000, replaces 41200-MZ5-670)	001	\$127.81
02	ARRESTER, NOISE 41212-MK4-010 (replaces 41212-MK4-000)	001	\$8.29
03	DAMPER, RR. WHEEL 41241-MM5-000	005	\$10.47
04	SLEEVE, RR. AXLE 42606-MS2-000	001	\$15.93
05	FLANGE, FINAL DRIVEN 42610-MS2-000	001	\$243.35
06	COLLAR, RR. 42620-MZ5-000	001	\$19.36
07	WHEEL SET, RR. 42650-MZ5-305	001	\$705.94
08	WEIGHT (10G) 42704-MB0-000	AR	\$9.07
08	WEIGHT (20G) 42705-MB0-000	AR	\$10.36
08	WEIGHT, BALANCE (20) 42705-MCF-D60	AR	\$10.36

#	Description	Q'ty	Price
08	WEIGHT, BALANCE (30) 42706-MCF-D60 (replaces 42706-MB0-000)	AR	\$10.36
09	TIRE, RR. 42711-MZ5-024 (replaces 42710-MZ5-004, 42711-MZ5-004)	001	\$152.63
11	VALVE, RIM 42753-ML7-004	001	\$9.67
12	NUT, FLANGE (12MM) 90306-KF0-003	005	\$3.15
13	OIL SEAL (34X62.2X7) 90753-MG5-670	001	\$9.20
14	BEARING, BALL RADI 91051-MBT-611 (replaces 91051-MAT-003, 91051-MM5-003)	001	\$23.11
15	BEARING (6204UU) 91052-MM5-003	001	\$23.13
16	BEARING (6304UU) 91053-MM5-004	001	\$24.36
17	O-RING (69X2) 91302-MS2-003	001	\$3.07
18	BOLT, STUD (12X28) 92918-12028-0E	005	\$2.15

Right Crankcase Cover

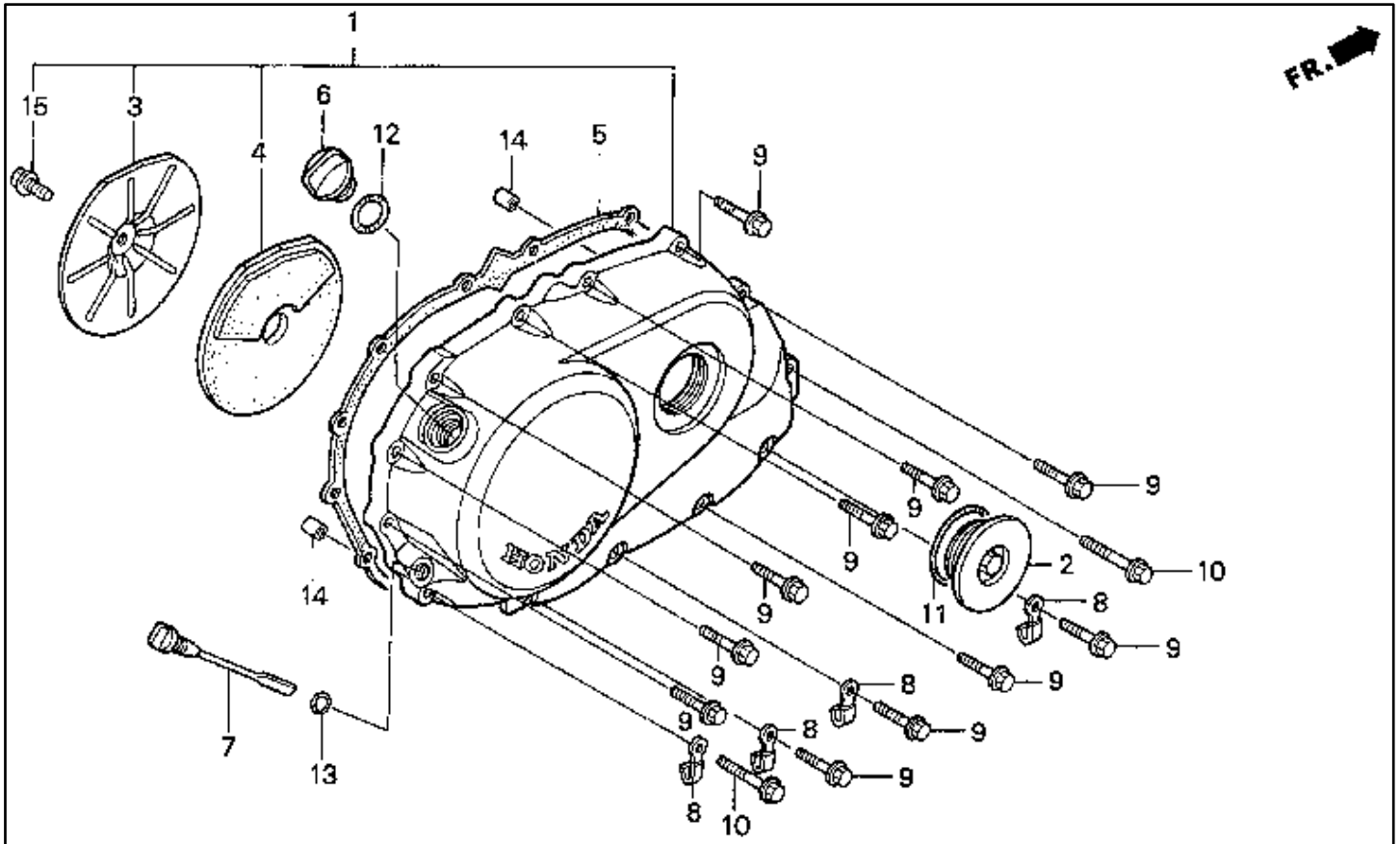

#	Description	Q'ty	Price
01	COVER, R. CRANKCASE 11330-MZ5-920 (replaces 11330-MZ5-000)	001	\$405.03
02	CAP (45MM) 11332-MZ5-000	001	\$25.67
03	PLATE, R. COVER 11333-MV8-900	001	\$14.84
04	RUB, R. COVER DAMPER 11334-MT7-300	001	\$31.35
05	GASKET, R. 11394-MY7-000	001	\$18.08
06	CAP, OIL FILLER 15611-MB0-000	001	\$7.36
07	DIPSTICK, OIL 15650-ML7-000	001	\$10.67
08	CLAMP, SWITCH WIRE 35211-443-760	004	\$2.93

#	Description	Q'ty	Price
09	BOLT, FLANGE (6X28) 90004-GHB-680 (replaces 90001-GHB-680)	011	\$2.16
10	BOLT, FLANGE (6X32) 90001-GHB-690	002	\$2.96
11	O-RING (48.1X3.6) 91301-ML7-003	001	\$3.11
12	O-RING (22X3.0) 91307-425-003 (replaces 91301-250-000)	001	\$1.47
13	O-RING (8.4X2.4) 91316-MJ8-003	001	\$1.87
14	PIN, DOWEL (8X14) 94301-08140	002	\$1.00
15	BOLT, FLANGE (6X10) 95701-06010-00	001	\$0.75

Seat

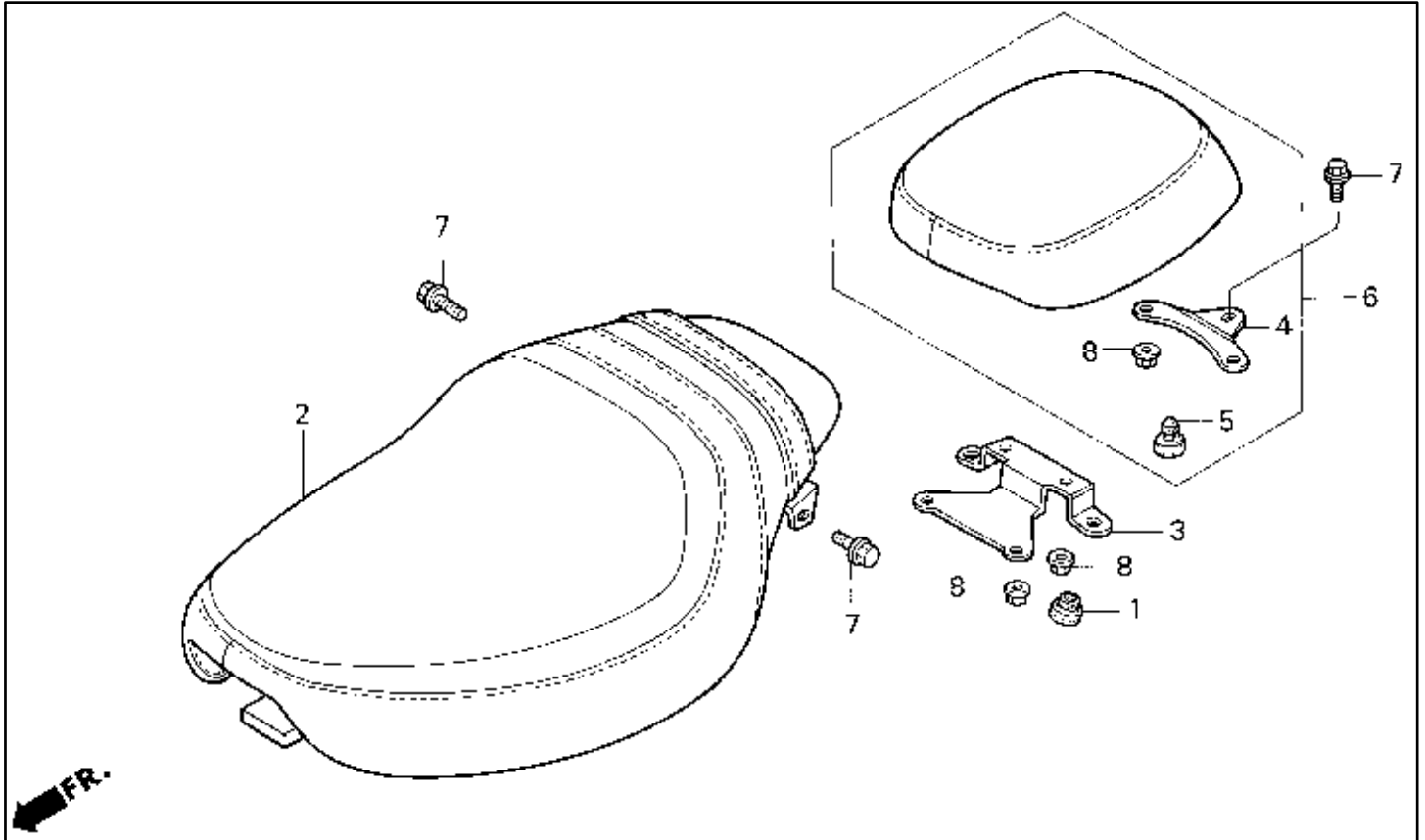

#	Description	Q'ty	Price
01	RUB. SEAT MOUNTING 77110-KA3-730	002	\$3.96
02	SEAT ASSY. 77200-MZ5-000	001	\$308.50
03	STAY A, RR. SEAT 77206-MZ5-000	001	\$15.89
04	STAY B, RR. SEAT 77207-MZ5-000	001	\$12.82

#	Description	Q'ty	Price
05	RUBBER B 77215-GC2-000	002	\$3.96
06	SEAT ASSY., RR. 77300-MZ5-000	001	\$188.28
07	BOLT (8X12) 90125-KR3-000	003	\$3.07
08	NUT, FLANGE (6MM) 94050-06080	006	\$0.23

Side Cover

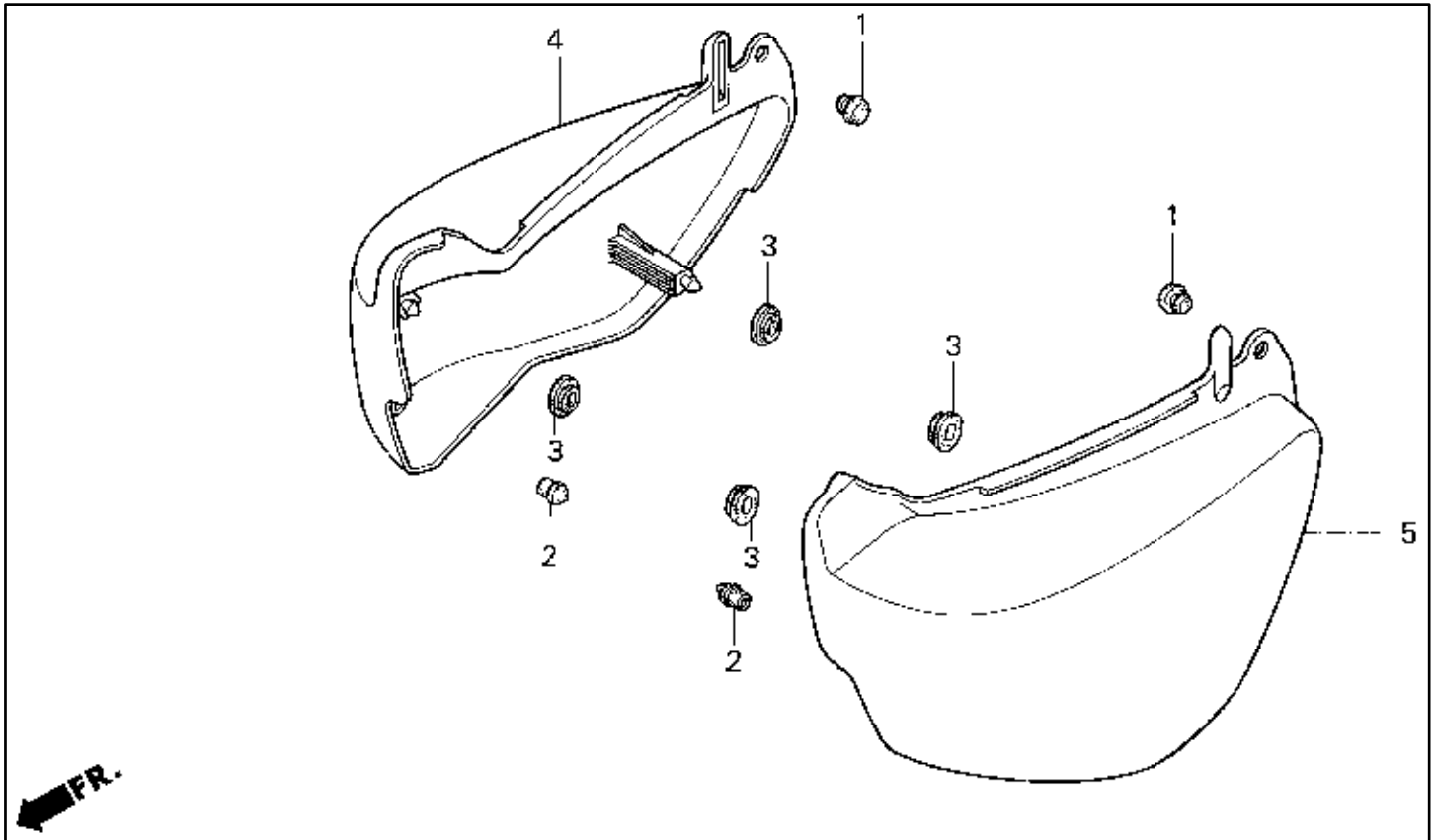

#	Description	Q'ty	Price
01	RUBBER B, STOPPER 50354-428-000	002	\$2.09
02	CAP, STEP HOLDER END 50713-ML0-720	002	\$2.16
03	GROMMET, A/CLNR HSG 83551-300-000	004	\$2.96
04	COVER, R. SIDE *NH1* 83650-MZ5-000ZC	001	\$95.47
04	CVR, R. SIDE *Y124P* 83650-MZ5-000ZD	001	\$84.82

#	Description	Q'ty	Price
04	CVR, R. SIDE *R201* 83650-MZ5-000ZE	001	\$142.83
05	COVER, L. SIDE *NH1* 83750-MZ5-000ZC	001	\$84.82
05	CVR, L. SIDE *Y124P* 83750-MZ5-000ZD	001	\$84.82
05	CVR, L. SIDE *R201* 83750-MZ5-000ZE	001	\$152.19

Speedometer Tachometer

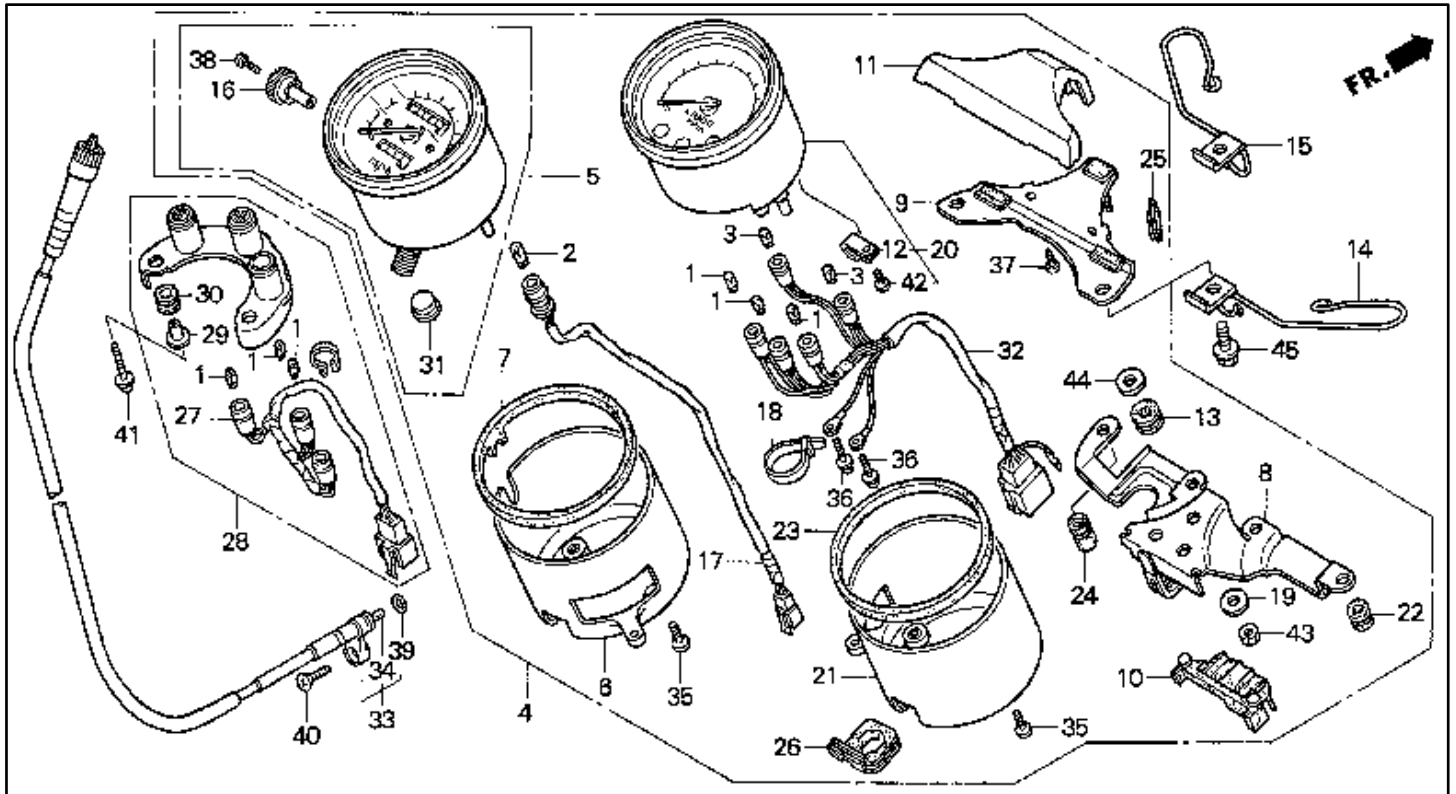

#	Description	Q'ty	Price
01	BULB (12V3W) 34908-KM1-671	006	\$1.68
02	BULB (12V1.7W) 34908-MB9-871	001	\$1.95
03	BULB (12V1.4W) 34908-MN8-700	002	\$2.27
04	METER, COMBINATION 37100-MZ5-671	001	\$974.79
05	SPEEDOMETER ASSY. 37200-MZ5-671	001	\$363.85
06	COVER, SPEEDOMETER 37202-MZ5-008	001	\$58.98
07	RUBBER, SPEEDOMETER 37204-MK4-611	001	\$7.15
08	BRKT, METER (LOWER) 37211-MZ5-008	001	\$65.47
09	BRKT, METER (UPPER) 37212-MZ5-008	001	\$57.34
10	RUBBER 37213-MW3-671	001	\$7.27
11	COVER, METER BRACKET 37214-MZ5-008	001	\$70.22
12	CLAMP 37215-KM1-670	001	\$1.53
13	RUB, BRACKET SETTING 37215-MW3-671	003	\$1.60
14	GUIDE, R. CABLE 37216-MZ5-000	001	\$8.82
15	GUIDE, L. CABLE 37217-MZ5-000	001	\$10.78
16	KNOB, TRIP METER 37220-MB4-671	001	\$10.04
17	SOCKET 37224-MZ5-008	001	\$35.71
18	BAND, SELF-LOCK 37226-MZ5-008	002	\$2.35
19	WASHER, PLAIN 37244-MA6-008	003	\$1.60
20	TACHOMETER ASSY. 37250-MZ5-671	001	\$409.83
21	COVER, TACHOMETER 37252-MZ5-008	001	\$59.10
22	RUBBER 37253-MK4-611	002	\$2.33
23	RUBBER, TACHOMETER 37254-MK4-611	001	\$7.15
24	RUBBER 37255-MK4-611	002	\$2.33

#	Description	Q'ty	Price
25	CUSHION, RUBBER 37255-MZ5-008	002	\$2.44
26	GROMMET, TACHOMETER 37257-MK4-601	001	\$5.13
27	SOCKET 37562-MZ5-008	001	\$43.49
28	BOX ASSY., PILOT 37600-MZ5-008	001	\$80.14
29	COLLAR 37606-MR1-008	002	\$4.00
30	RUBBER, SETTING 37607-MZ5-008	002	\$4.62
31	CAP 37618-MB2-008	001	\$1.60
32	SOCKET, METER 37619-MZ5-671	001	\$117.14
33	CABLE, SPEEDOMETER 44830-MT3-000	001	\$23.23
34	CABLE (INNER) 44831-MM5-000 (replaces 44831-443-720)	001	\$4.46
35	SCREW, TRUSS (4X12) 90106-KN8-008	004	\$1.51
36	SCREW-WASHER (3X10) 90108-GN2-008	002	\$1.65
37	SCREW, TAP (4X14) 90109-MZ5-008	002	\$3.24
38	SCREW, PAN (2X6) 90158-KM7-911	001	\$1.42
39	O-RING (6.8X1.9) 91306-PJ4-000 (replaces 91301-027-000, 91310-MC7-003)	001	\$1.43
40	SCREW, OVAL (5X20) 93700-05020-0G	001	\$0.35
41	SCREW-WASHER (4X16) 93891-04016-07	002	\$0.37
42	SCREW, TAP (4X12) 93903-24310	001	\$0.47
43	NUT, HEX. (6MM) 94002-06070-0S	003	\$0.55
44	WASHER, PLAIN (8MM) 94101-08700	003	\$0.45
45	BOLT, FLANGE (8X16) 95701-08016-08	002	\$0.85

Stand

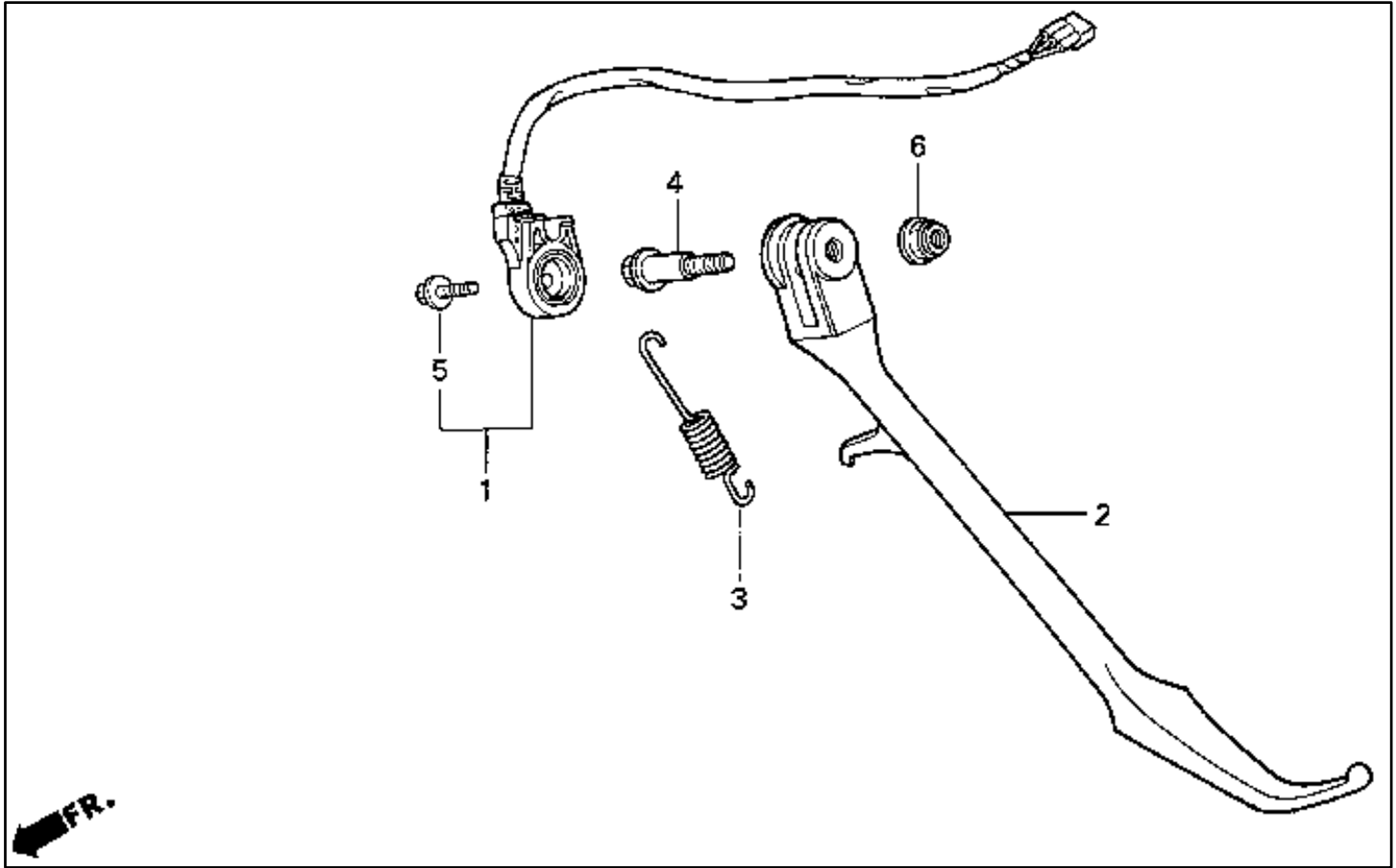

#	Description	Q'ty	Price
01	SWITCH, SIDE STAND 35070-MZ5-A80 (replaces 35700-MZ5-305)	001	\$41.75
02	BAR, SIDE STAND 50532-MZ5-000	001	\$69.70
03	SPRING, SIDE STAND 50541-KV3-830	001	\$6.04

#	Description	Q'ty	Price
04	BOLT 90108-MR5-000	001	\$6.31
05	BOLT, SPECIAL (6X16) 90147-MCE-950 (replaces 90147-MK6-671)	001	\$1.84
06	NUT, SIDE STAND 90203-MF9-710	001	\$2.84

Starting Motor

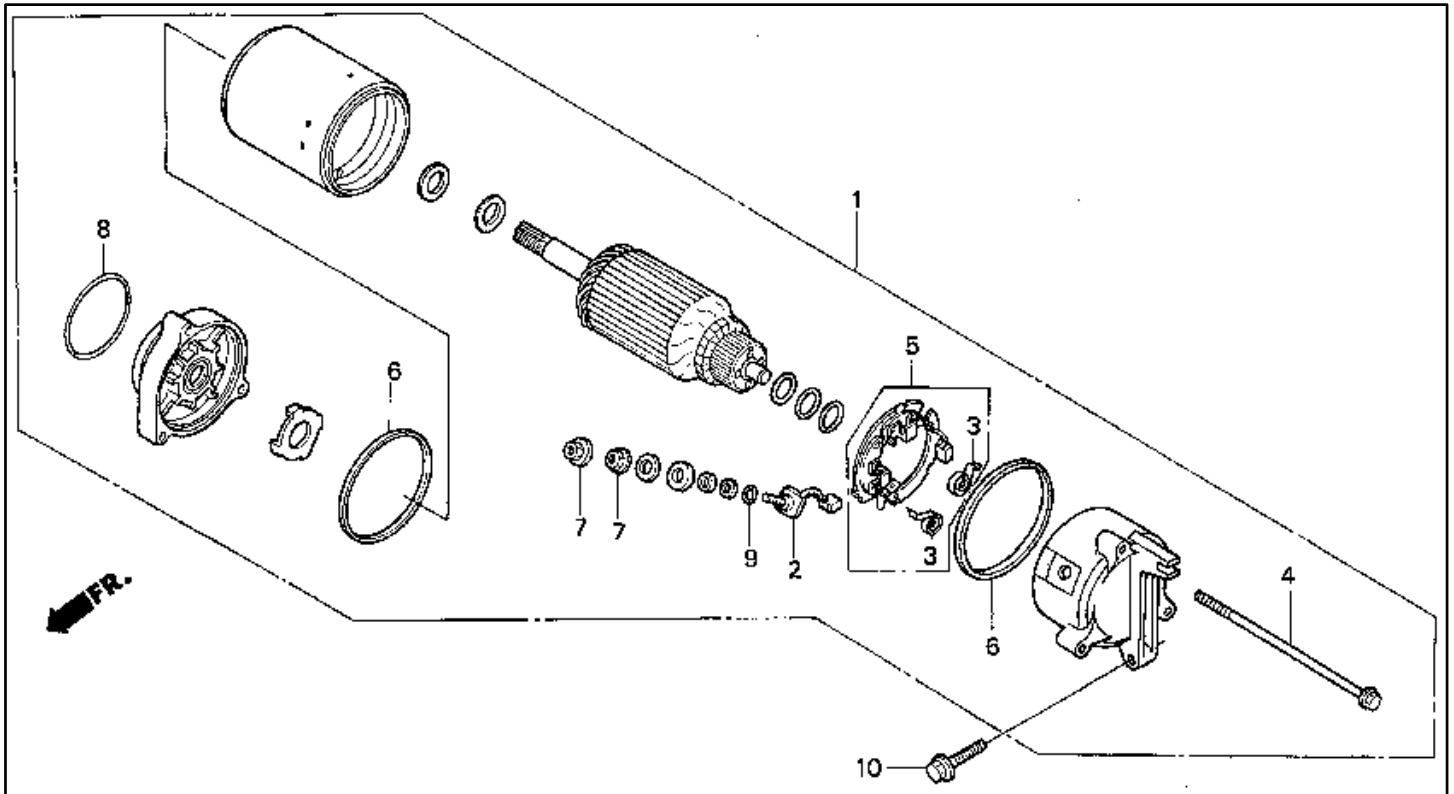

#	Description	Q'ty	Price
01	MOTOR ASSY., STARTER 31200-MZ5-003	001	\$455.40
02	TERMINAL SET, BRUSH 31201-KS5-901	001	\$17.73
03	SPRING, CARBON BRUSH 31204-KS5-901	002	\$2.20
04	BOLT, SETTING 31205-MN0-008	003	\$3.93
05	HOLDER SET, BRUSH 31206-KW1-901	001	\$18.91

#	Description	Q'ty	Price
06	RING 31207-KS5-901	002	\$2.58
07	NUT-WASHER (6MM) 90071-MB0-000	002	\$1.53
08	O-RING 91309-MA6-000	001	\$2.93
09	O-RING 91320-MB0-000	001	\$1.82
10	BOLT, FLANGE (6X25) 96001-06025-00	002	\$0.93

Steering Stem

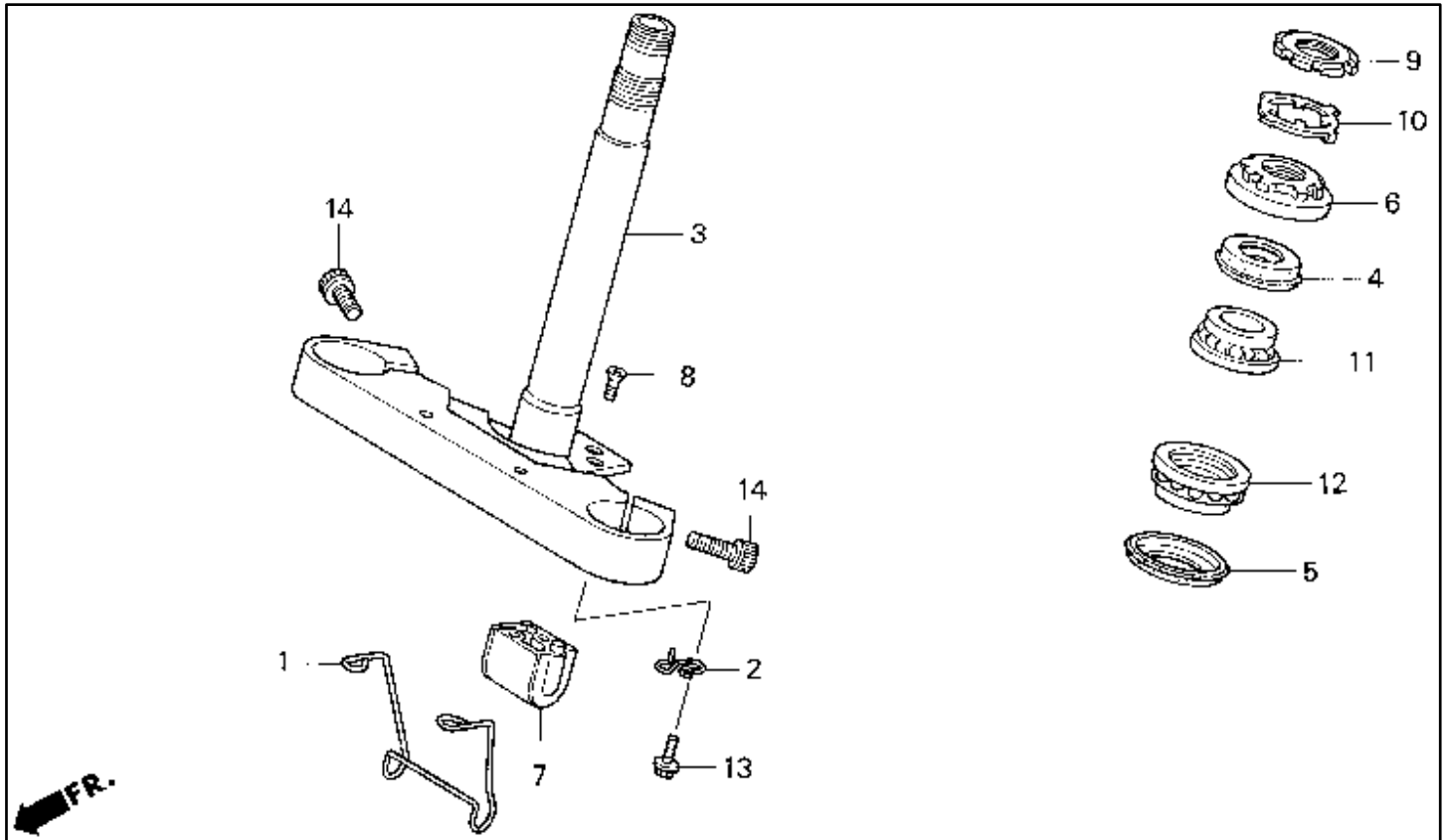

#	Description	Q'ty	Price
01	CLAMP A, BRAKE HOSE 45131-MZ5-000	001	\$10.53
02	CLAMP 53105-MZ5-000	001	\$6.60
03	STEM, STEERING 53200-MZ5-000	001	\$320.76
04	DUST SEAL 53213-MB4-771	001	\$9.20
05	DUST SEAL 53214-371-010	001	\$9.56
06	THREAD (UPPER) 53220-422-000	001	\$24.84
07	LOCK, HANDLEBAR 53600-086-007 (replaces 53600-126-921)	001	\$34.24

#	Description	Q'ty	Price
08	SCREW (6X12) 90164-028-000	002	\$1.25
09	THREAD 90302-425-830	001	\$16.51
10	WASHER, LOCK 90506-425-830	001	\$5.67
11	BEARING, HEAD PIPE 91015-KT8-005	001	\$30.15
12	BEARING, HEAD PIPE 91016-KT8-005	001	\$30.15
13	BOLT, FLANGE (6X12) 95701-06012-00	001	\$0.72
14	BOLT, SOCKET (10X25) 96700-10025-10	002	\$1.48

Step

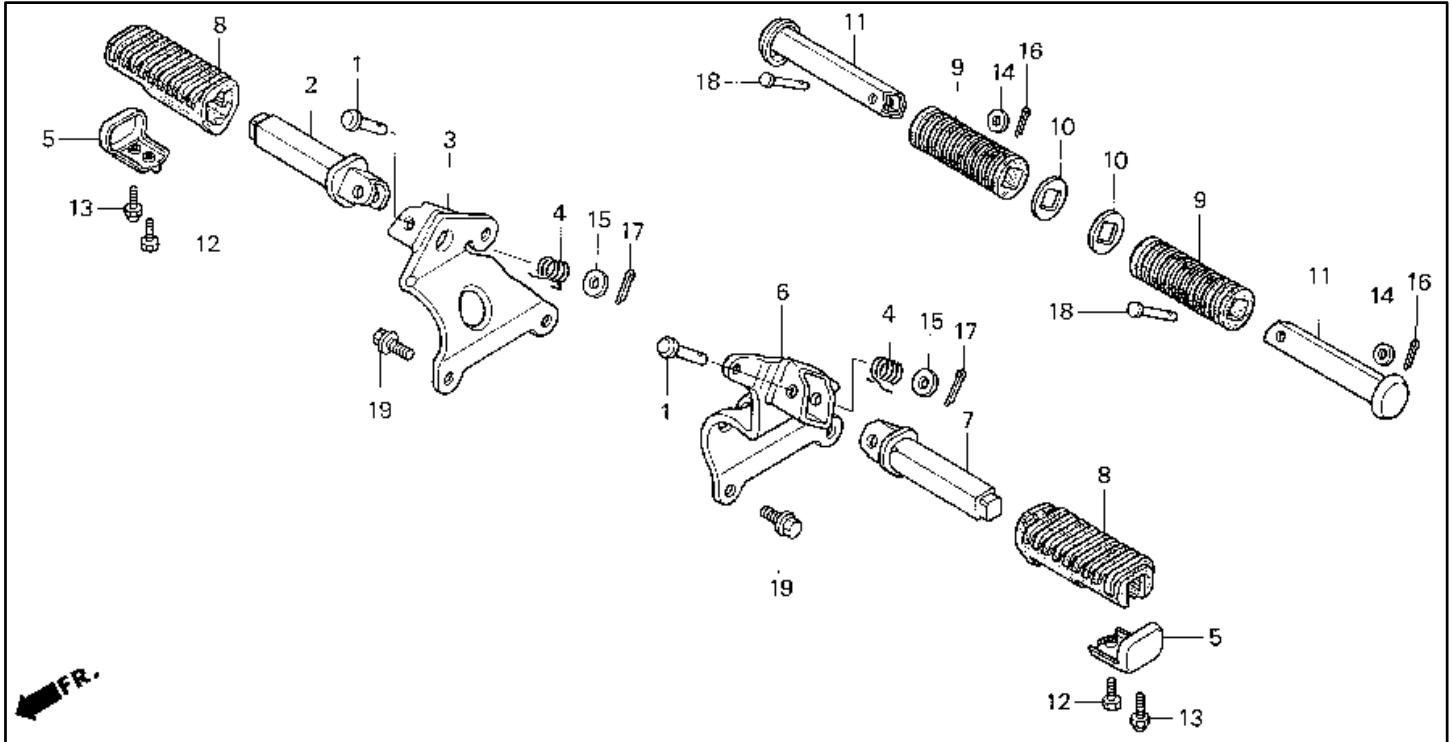

#	Description	Q'ty	Price
01	PIN, STEP BAR JOINT 50603-033-010	002	\$2.55
02	BAR, R. STEP 50612-MR1-000	001	\$21.58
03	BRACKET, R. STEP 50615-MZ5-000	001	\$88.37
04	SPRING, STEP RETURN 50617-MB1-700	002	\$4.55
05	STOPPER, STEP RUBBER 50619-MN0-000	002	\$13.18
06	BRACKET, L. STEP 50625-MZ5-000	001	\$91.59
07	BAR, L. STEP 50642-MR1-000	001	\$21.58
08	RUBBER, MAIN STEP 50661-MN0-000	002	\$8.16
09	RUB, PILLION FOOTPEG 50716-371-660 (replaces 50710-377-000)	002	\$10.78
10	WASHER 50712-413-000	002	\$2.62

#	Description	Q'ty	Price
11	BAR, PILLION STEP 50715-MN0-000	002	\$25.25
12	BOLT, HEX. (6X12) 92101-06012-0A	002	\$0.53
13	BOLT, CAP (6X12) 92501-06012-0A	002	\$1.75
14	WASHER, PLAIN (6MM) 94101-06800 (replaces 94101-06000, 94101-06080)	002	\$0.30
15	WASHER, PLAIN (8MM) 94101-08000	002	\$0.40
16	PIN, SPLIT (1.6X12) 94201-16120	002	\$0.43
17	PIN, SPLIT (2.0X15) 94201-20150	002	\$0.35
18	PIN A, PILLION STEP 95015-81000	002	\$1.58
19	BOLT, FLANGE (8X18) 95701-08018-00	004	\$0.83

Swingarm @ Drive Chain

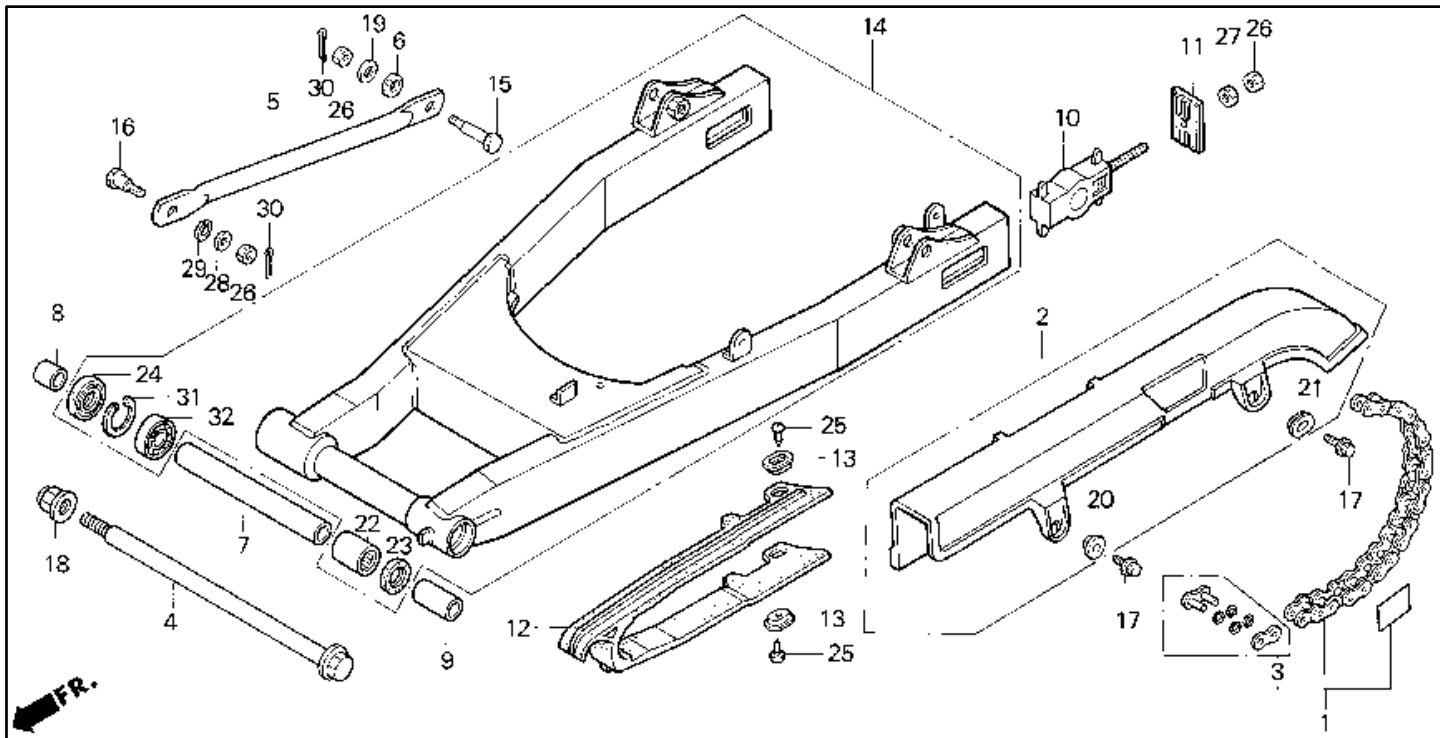

#	Description	Q'ty	Price
01	CHAIN SET, DRIVE 06405-MZ5-P20 (replaces 06405-MZ5-405)	001	\$168.18
01	CHAIN SET, DRIVE 06405-MZ5-407	001	\$307.34
01	CHAIN SET, DRIVE 06405-MZ5-P20	001	\$168.18
02	CASE, DRIVE CHAIN 40510-MZ5-000	001	\$102.29
03	MASTER LINK 40535-MW0-305	001	\$5.18
03	MASTER LINK 40535-MW0-306	001	\$5.18
04	AXLE, RR. WHEEL 42301-KBG-000	001	\$26.85
05	ARM, RR. 43431-MZ5-000	001	\$12.65
06	RUBBER, STOPPER ARM 43434-ME1-670	001	\$2.73
07	COLR, PIVOT DISTANCE 52102-MM5-000	001	\$24.15
08	COLLAR B, SWINGARM 52105-MM2-670	001	\$8.11
09	COLLAR B, PIVOT 52106-ML4-000	001	\$16.45
10	COLLAR 52120-MJ0-010 (replaces 52120-MJ0-000)	002	\$42.35
11	PLATE 52121-MJ0-000	002	\$15.93
12	SLIDER, CHAIN 52170-MZ5-000	001	\$36.36
13	WASHER, CHAIN SLIDER 52171-KR6-000	002	\$1.87
14	SWINGARM SET 52200-MZ5-305	001	\$627.52
15	BOLT, RR. 90127-393-000	001	\$3.82
16	BOLT, RR. 90133-286-000	001	\$3.51

#	Description	Q'ty	Price
17	BOLT, FLANGE (6X12) 90154-ML0-000	002	\$1.67
18	NUT, U (14MM) 90305-GE8-003	001	\$3.05
19	WASHER A 90524-030-000 (replaces 90505-425-000)	001	\$1.04
20	WASHER (6X20) 90512-KF9-900	001	\$2.33
21	WASHER (6X9) 90513-405-000 (replaces 90513-428-900)	001	\$0.98
22	BEARING (22X29X30) 91071-MJ0-003	001	\$27.96
22	BEARING, NEEDLE 91071-MJ0-004	001	\$27.96
23	OIL SEAL (22X31X5) 91205-965-003	001	\$4.71
24	DUST SEAL (22X35X7) 91213-MB2-003 (replaces 91213-MB2-006)	001	\$5.87
25	SCREW, TAP (5X12) 93901-25280	002	\$0.47
26	NUT, HEX. (8MM) 94001-08000-0S	004	\$0.52
27	NUT, HEX. (8MM) 94030-08000	002	\$0.48
28	WASHER, PLAIN (8MM) 94101-08000	001	\$0.40
29	WASHER (10MM) 94111-10000	001	\$0.60
30	PIN, COTTER (2.0X35) 94201-20350 (replaces 94201-20180, 94201-20200, 94201-20250, 94201-20280, 94201-20320)	002	\$0.65
31	CIRCLIP (35MM) 94520-35000	001	\$1.00
32	BEARING (6202) 96100-62020-10	001	\$8.90

Taillight

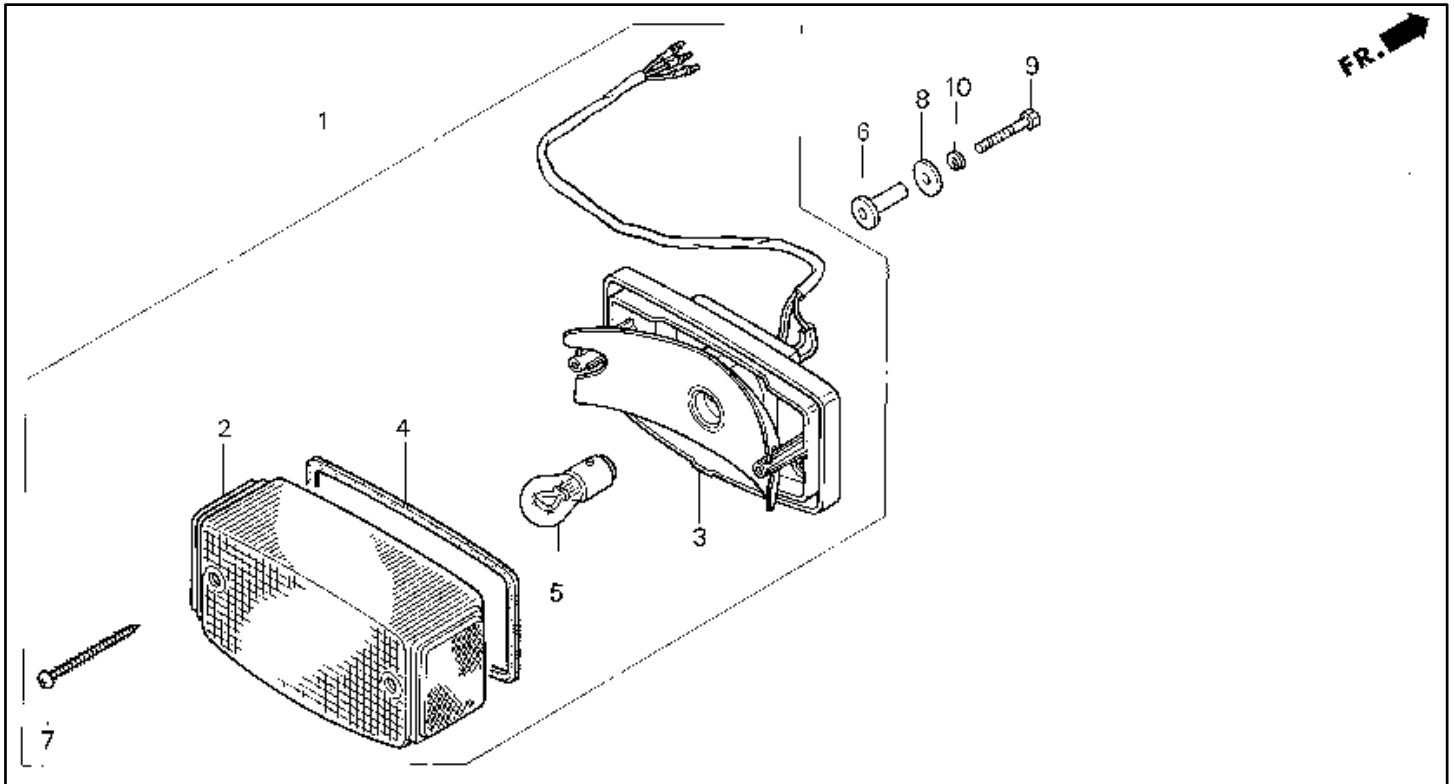

#	Description	Q'ty	Price
01	TAILLIGHT UNIT 33701-MZ5-671	001	\$103.47
02	LENS, TAILLIGHT 33702-MC4-671	001	\$22.96
03	SOCKET, TAILLIGHT 33703-MZ5-671	001	\$51.15
04	GSKT, TAILLIGHT LENS 33709-KB7-003	001	\$3.31
05	BULB (12V27/8W) 34906-425-771	001	\$3.18

#	Description	Q'ty	Price
06	COLLAR 80135-MZ5-000	002	\$9.98
07	SCREW, TAP (4X40) 90105-GAM-000	002	\$3.87
08	WASHER (5MM) 91409-VM0-770	002	\$2.33
09	BOLT, HEX. (5X35) 92101-05035-0A	002	\$1.28
10	WASHER, SPRING (5MM) 94111-05000	002	\$0.50

Tools

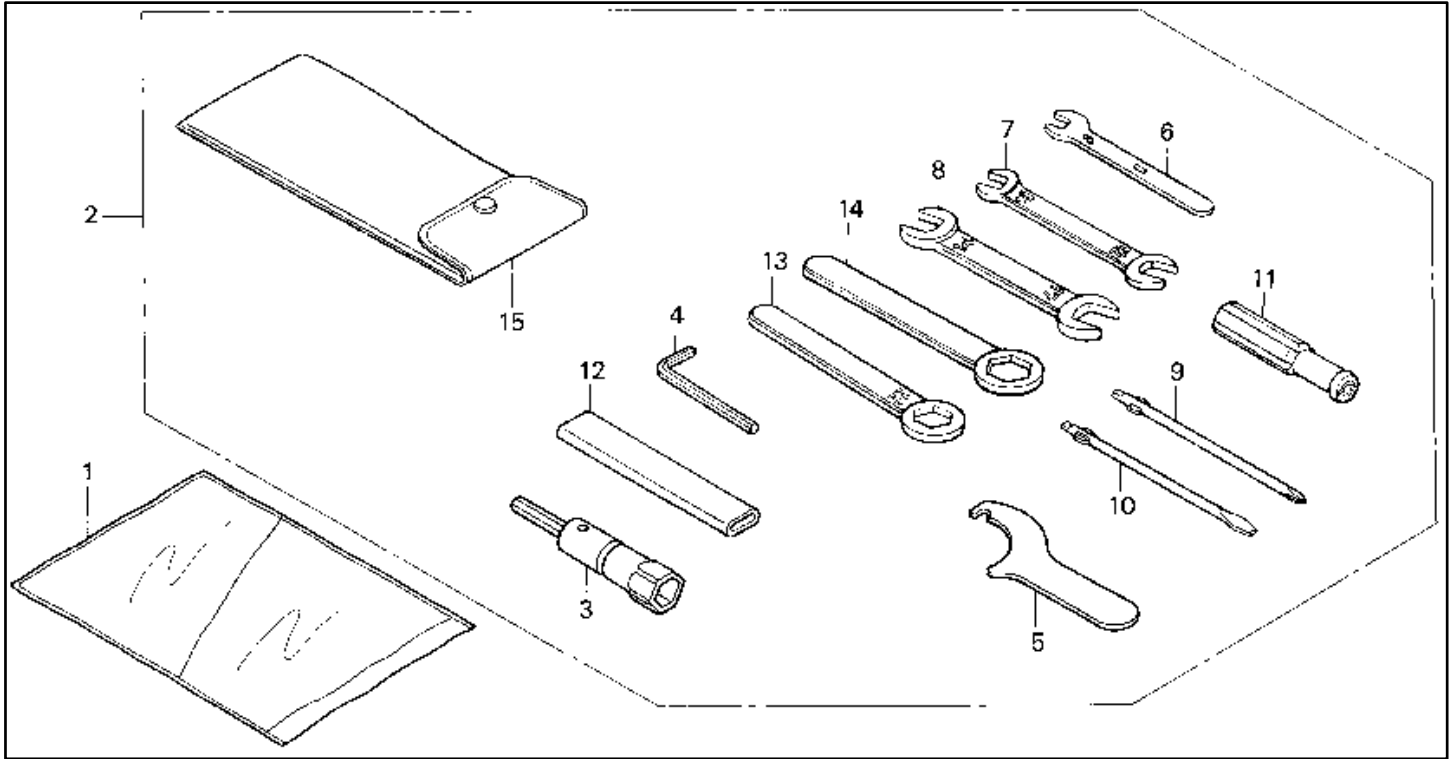

#	Description	Q'ty	Price
01	BAG, SERVICE BOOK 77251-GR1-000	001	\$3.38
02	TOOL SET 89010-MZ5-000	001	\$52.58
03	WRENCH, PLUG (16.5) 89216-MT3-000	001	\$19.29
04	WRENCH, HEX. (5MM) 89221-429-000	001	\$4.22
05	WRENCH, PIN 89230-MB1-000	001	\$15.98
06	WRENCH (8MM) 99001-08000	001	\$1.89
07	SPANNER (10X12) 99001-10120	001	\$1.72
08	SPANNER (14X17) 99001-14170	001	\$2.75

#	Description	Q'ty	Price
09	SCREWDRIVER 1 (NO.2) 99003-10000	001	\$1.75
10	SCREWDRIVER 3 (NO.2) 99003-30000	001	\$0.82
11	GRIP 99003-50000	001	\$1.80
12	HANDLE (12MM) 99006-12000	001	\$2.60
13	WRENCH, EYE (22MM) 99006-22000	001	\$3.31
14	WRENCH, EYE (27MM) 99006-27000	001	\$3.49
15	BAG, TOOL (160MM) 99008-01600	001	\$1.51

Transmission

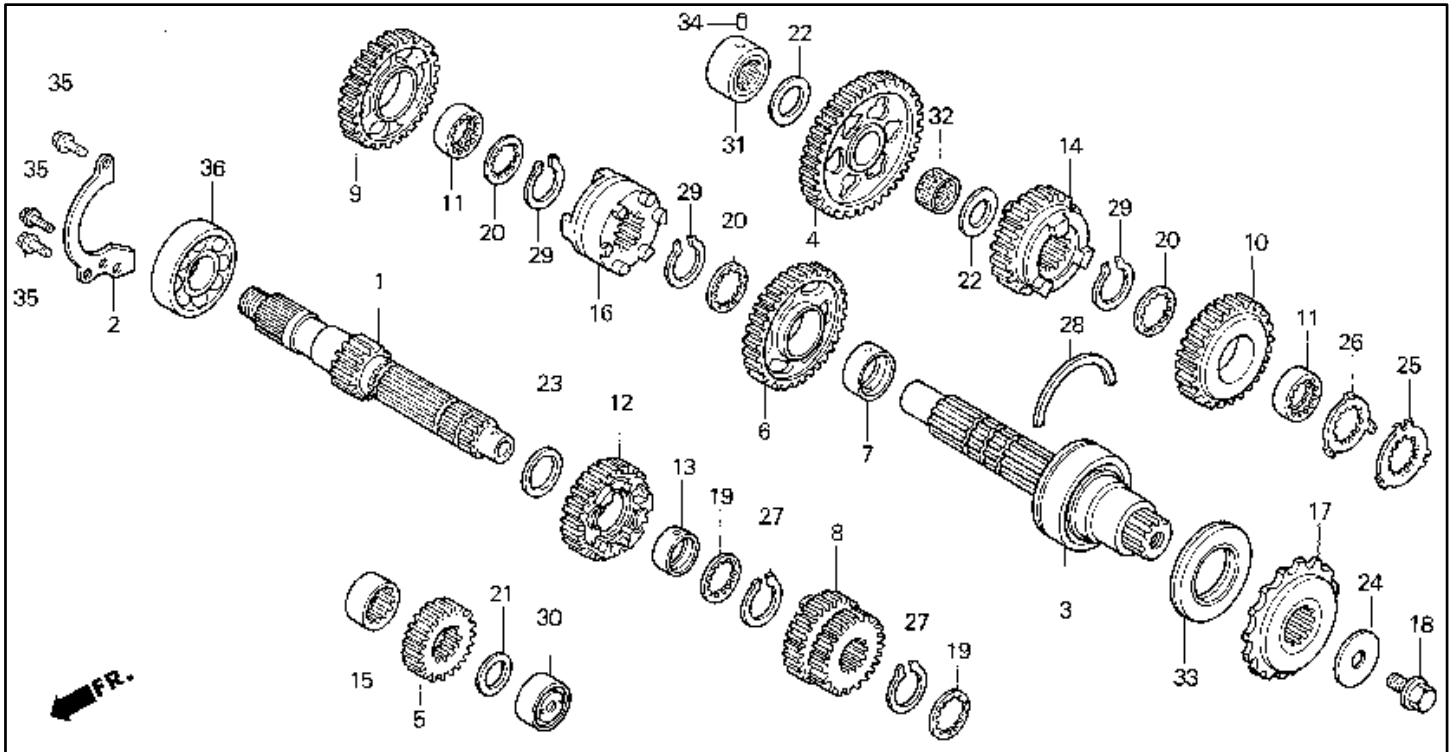

#	Description	Q'ty	Price
01	MAINSHAFT (13T) 23211-ML7-920	001	\$146.95
02	PLATE 23212-ML7-000	001	\$8.73
03	COUNTERSHAFT 23220-MT4-000	001	\$223.89
04	GEAR (37T) 23421-ML7-000	001	\$110.83
05	GEAR (17T) 23431-MV8-900	001	\$40.44
06	GEAR (32T) 23441-MV8-900	001	\$92.55
07	COLLAR (28MM) 23442-ML7-000	001	\$19.96
08	GEAR 23451-MZ5-000	001	\$110.83
09	GEAR (29T) 23461-MV8-900	001	\$101.60
10	GEAR (27T) 23481-MV8-900	001	\$98.99
11	COLLAR (28X13.5) 23482-MR7-000	002	\$22.11
12	GEAR 23491-MZ5-010	001	\$99.68
13	COLLAR (25X12) 23495-MB0-000	001	\$18.78
14	GEAR 23501-MZ5-010	001	\$112.42
15	COLLAR (25X18.4) 23512-MZ5-000	001	\$21.00
16	SHIFTER 23521-MV8-900	001	\$65.32
17	SPROCKET (16T) 23801-MCJ-000 (replaces 23801-ML7-920)	001	\$48.18
18	BOLT, SPECIAL (10MM) 90037-422-003	001	\$5.78
19	WASHER (25X31X1.5) 90451-MR7-000	002	\$3.89
20	WASHER (28X34X1.5) 90452-MR7-000	003	\$4.58

#	Description	Q'ty	Price
21	WASHER (20X1.00) 90454-428-000	001	\$2.02
22	WASHER B (22MM) 90455-ML7-000	002	\$3.89
22	WASHER A (22MM) 90456-ML7-000	002	\$3.89
22	WASHER C (22MM) 90457-ML7-000	002	\$3.89
23	WASHER (25MM) 90456-MA6-000	001	\$2.02
24	WASHER (10.2MM) 90459-438-000	001	\$4.67
25	WASHER (28MM) 90463-MR7-000	001	\$7.71
26	WASHER, LOCK (28MM) 90464-MR7-000	001	\$7.71
27	CIRCLIP (25MM) 90601-107-000	002	\$2.91
28	SET-RING (68MM) 90602-MR7-000	001	\$6.36
29	CIRCLIP (28MM) 90602-MM5-000 (replaces 90603-MN4-000)	003	\$2.91
30	BEARING (20MM) 91022-MT4-000	001	\$30.56
31	BEARING (22MM) 91023-MZ5-003	001	\$40.07
32	BEARING (22X26X11) 91026-MB4-003	001	\$22.58
33	OIL SEAL (40X68X7.2) 91207-MR7-003	001	\$11.24
34	PIN B, DOWEL (8X10) 94302-08100	001	\$1.03
35	*95701-06016-08 95701-06016-00	003	\$0.73
36	BEARING (6305) 96100-63050-00	001	\$11.98

Turn Signal

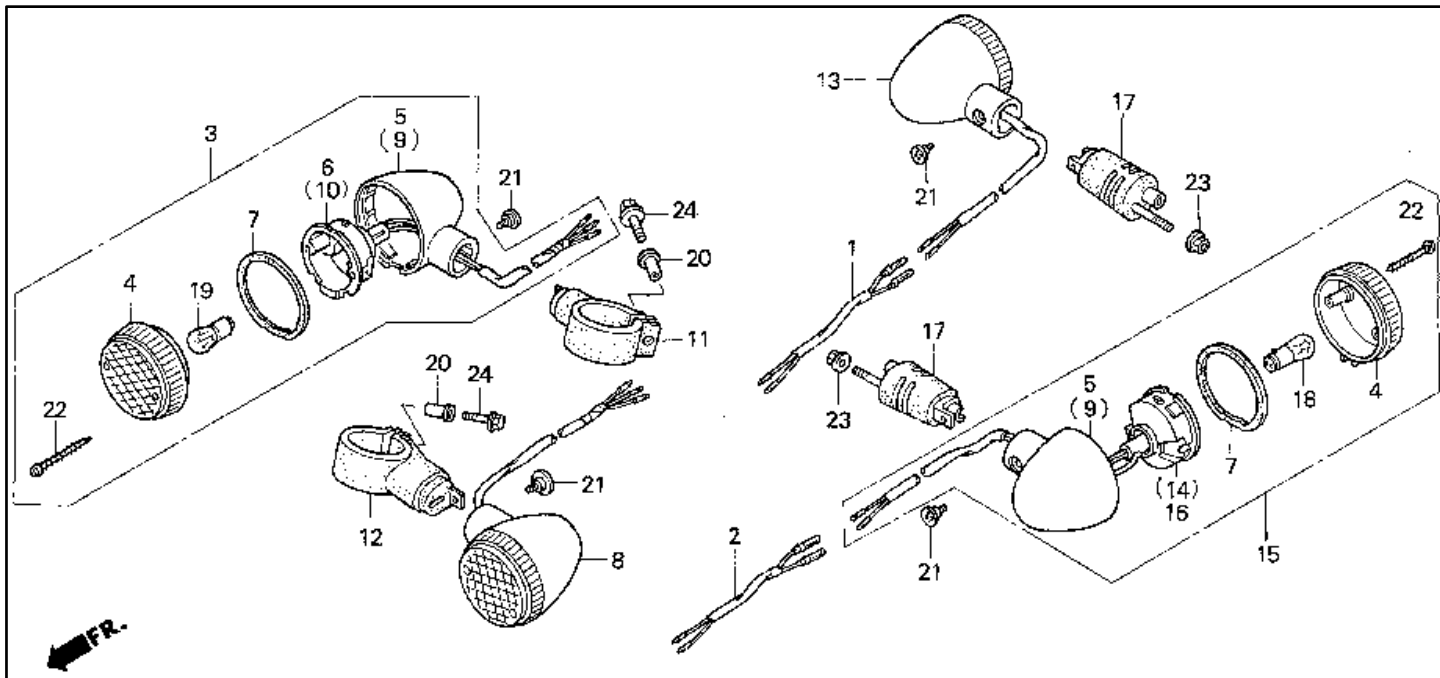

#	Description	Q'ty	Price
01	SUB-WIRE, R. RR. 32360-MZ5-000	001	\$14.73
02	SUB-WIRE, L. RR. 32365-MZ5-000	001	\$10.69
03	WINKER LIGHT ASSY 33400-MK7-P00 (replaces 33400-MN0-003)	001	\$49.09
04	LENS, FR. 33401-MK7-672	004	\$8.46
05	BASE, R. FR. 33402-MK7-671	002	\$34.20
06	REFLECTOR, R. RR. 33405-MN0-003	001	\$18.04
07	GASKET 33407-MK7-671	004	\$3.07
08	TURN SIGNAL, L. FR. 33450-MN0-003	001	\$38.04
09	BASE, L. FR. 33452-MK7-671	002	\$34.20
10	REFLECTOR, L. RR. 33455-MN0-003	001	\$15.69
11	STAY, R. FR. 33490-MZ5-000	001	\$39.56
12	STAY, L. FR. 33491-MZ5-000	001	\$39.56

#	Description	Q'ty	Price
13	TURN SIGNAL ASSY. 33600-MR1-000	001	\$49.11
14	REFLECTOR, R. RR. 33605-MR1-000	001	\$27.04
15	TURN SIGNAL ASSY. 33650-MR1-000	001	\$49.11
16	REFLECTOR, L. RR. 33655-MR1-000	001	\$27.04
17	STAY, RR. 33690-MZ5-000	002	\$23.75
18	BULB (12V23W32CP) 34905-268-671	002	\$1.67
19	BULB (12V23/8W) 34905-425-671	002	\$4.33
20	COLLAR 84702-KV0-670	002	\$4.00
21	SCREW, SPECIAL (6X8) 90380-MZ5-000	004	\$3.58
22	SCREW, TAP (4X25) 93901-34610	008	\$0.20
23	NUT, FLANGE (8MM) 94050-08080	002	\$0.25
24	BOLT, FLANGE (6X30) 96001-06030-07	002	\$1.15

Water Pipe

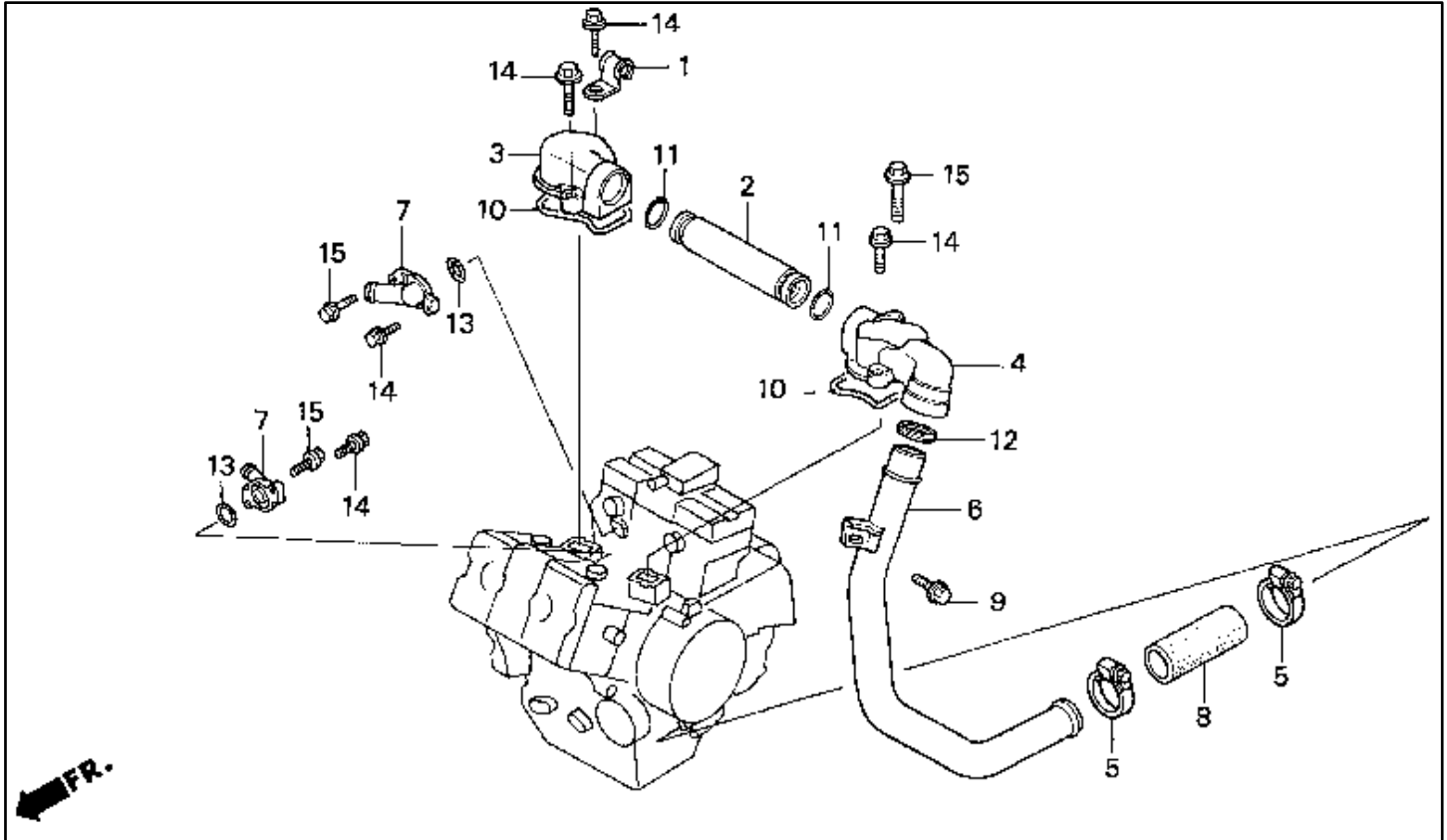

#	Description	Q'ty	Price
01	CLIP B, TUBE 16106-KW7-900	001	\$2.38
02	PIPE, CONNECTING 19507-MB0-000	001	\$17.71
03	CAP A 19508-MZ5-000	001	\$32.62
04	CAP B 19509-MZ5-000	001	\$41.04
05	CLAMP (24-32MM) 19516-ML7-691	002	\$10.95
06	PIPE A, WATER 19521-ML7-000	001	\$72.16
07	JOINT, WATER 19523-MT4-000	002	\$24.76
08	HOSE A, WATER 19525-ML7-000	001	\$6.31

#	Description	Q'ty	Price
09	BOLT, FLANGE (6X12) 90004-GHB-610 (replaces 90001-GHB-610)	001	\$2.33
10	GSKT, CONNECTING CAP 91301-MB0-000	002	\$3.05
11	O-RING (18.3X2.3) 91301-147-023	002	\$1.42
12	SEAL, WATER PIPE 91315-MB0-013	001	\$1.95
13	O-RING (21.2X2.4) 91331-PC9-003	002	\$1.95
14	BOLT, FLANGE (6X22) 96001-06022-00	005	\$0.91
15	BOLT, FLANGE (6X35) 96001-06035-00	003	\$1.00

Water Pump

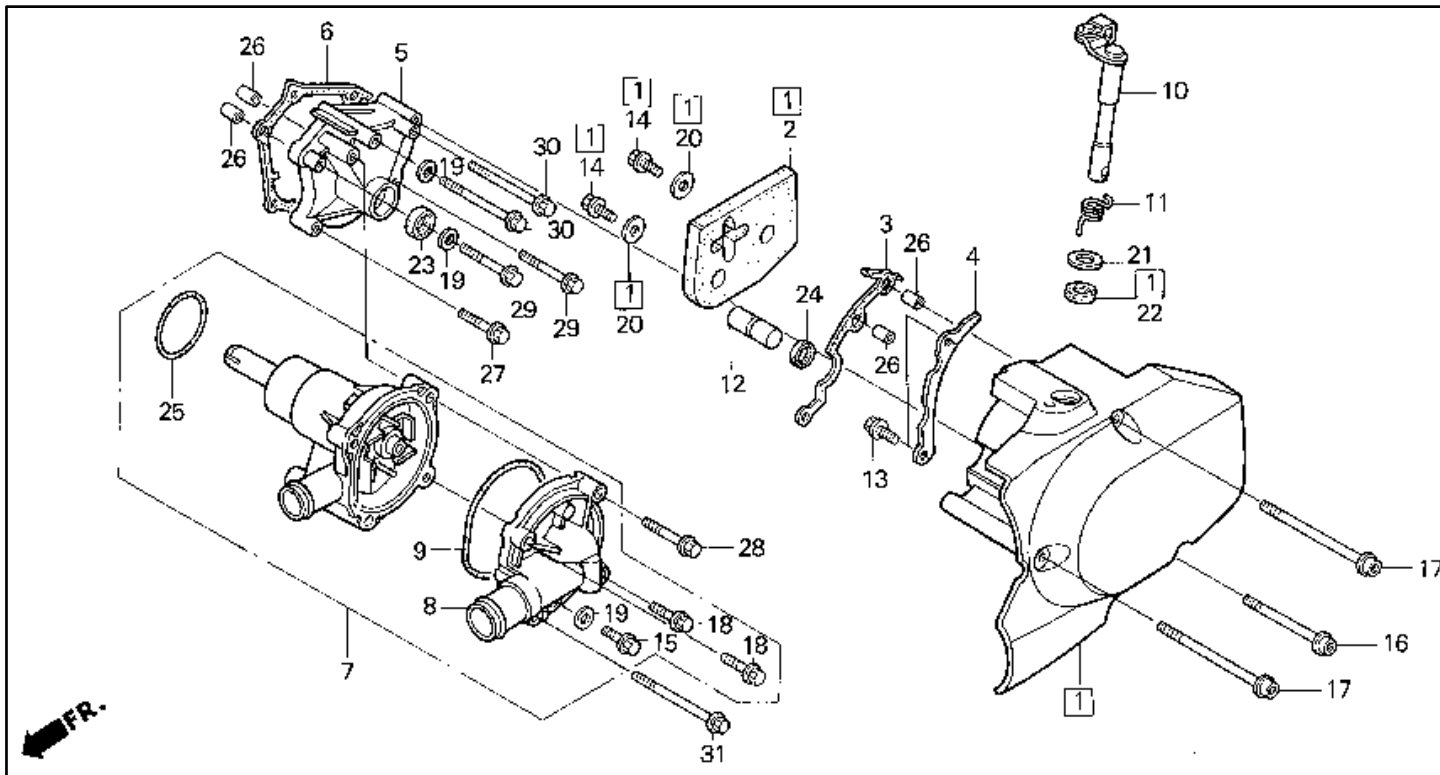

#	Description	Q'ty	Price
01	COVER, L. CRANKCASE 11340-MZ5-000	001	\$360.59
02	RUBBER, L. 11342-MZ5-300	001	\$33.87
03	GASKET, L. 11343-MZ5-000	001	\$4.57
04	GUIDE, DRIVE CHAIN 11365-MZ5-000	001	\$16.04
05	COVER, CHANGE 11630-MZ5-000	001	\$64.40
06	GASKET, SHIFT COVER 11632-MY7-000	001	\$9.47
07	WATER PUMP ASSY. 19200-MZ5-010 (replaces 19200-MZ5-000)	001	\$185.14
08	COVER, WATER PUMP 19220-MZ5-000 (replaces 19221-MZ5-305)	001	\$57.43
09	GASKET 19226-ML7-000	001	\$3.53
10	LEVER, CLUTCH 22710-MZ5-000	001	\$31.58
11	SPRING, CLUTCH LEVER 22815-MZ5-000	001	\$3.09
12	PIECE 22852-ML0-780	001	\$5.40
13	BOLT, FLANGE (6X16) 90004-GHB-630 (replaces 90001-GHB-630)	002	\$2.75
14	BOLT, FLANGE (6X10) 90011-HB9-000	002	\$1.67
15	BOLT (6X12) (CT200) 90013-883-000	001	\$1.34
16	BOLT (6X75) 90021-MZ5-000	001	\$6.78

#	Description	Q'ty	Price
17	BOLT (6X95) 90025-MZ5-000	002	\$8.53
18	BOLT, FLANGE (6X25) 90121-MV9-670	002	\$2.11
19	WASHER (6.5MM) 90463-ML7-000	003	\$2.25
20	WASHER, TANK RUBBER 90503-898-000	002	\$2.06
21	WASHER, BRAKE ARM 90525-GC4-700	001	\$1.73
22	OIL SEAL (12X20X6) 91201-427-003	001	\$3.91
23	OIL SEAL (13X22X5) 91204-KE8-003	001	\$2.58
24	O-RING (10.5X6.5) 91301-ML0-781	001	\$2.07
25	O-RING (32.95X2.62) 91302-MB0-013	001	\$2.07
26	PIN, DOWEL (8X14) 94301-08140	004	\$1.00
27	BOLT, FLANGE (6X32) 96001-06032-00	001	\$0.95
28	BOLT, FLANGE (6X35) 96001-06035-00	001	\$1.00
29	BOLT, FLANGE (6X40) 96001-06040-00	002	\$1.02
30	BOLT, FLANGE (6X60) 96001-06060-00	002	\$1.18
31	BOLT, FLANGE (6X75) 96001-06075-00	001	\$1.47

Wire Harness

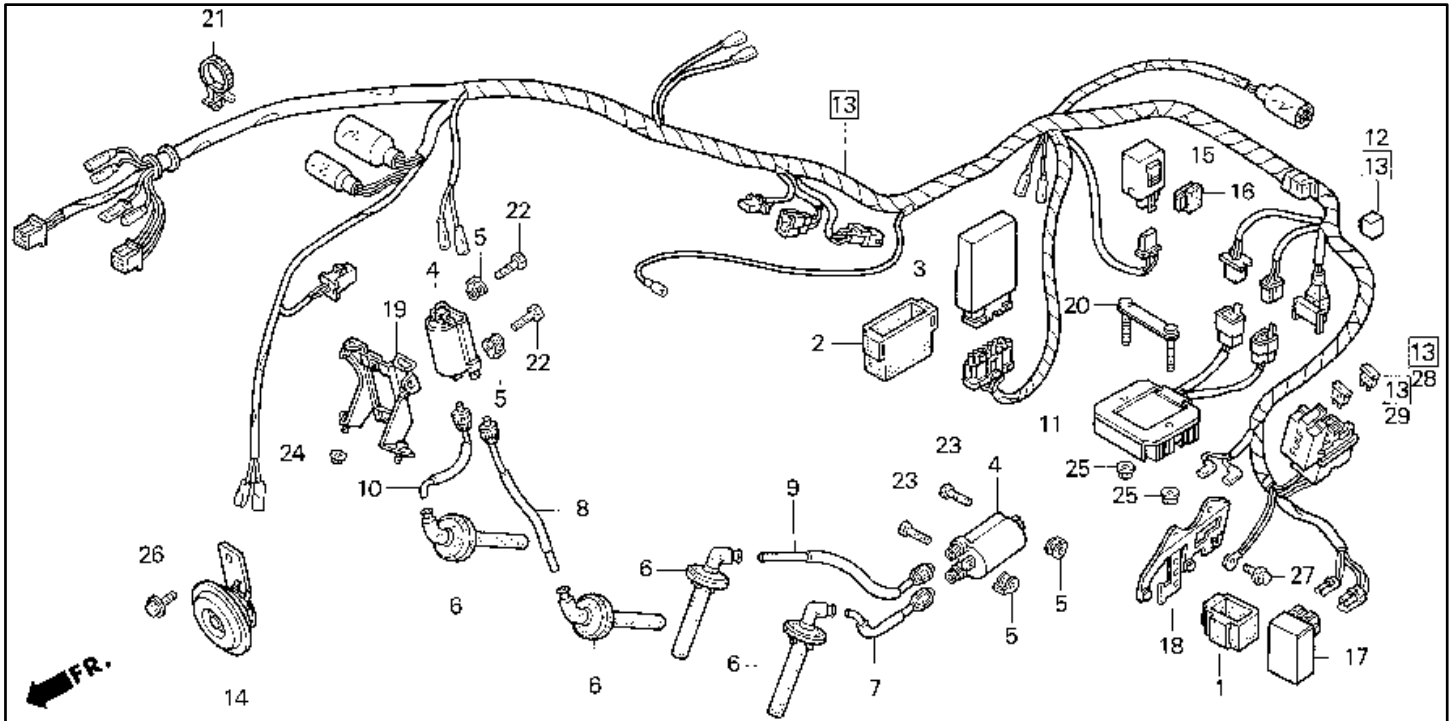

#	Description	Q'ty	Price
01	RUBBER 30401-GB6-000	001	\$4.22
02	RUBBER, SPARK UNIT 30405-MT6-000	001	\$19.40
03	MODULE, IGN CONT 30410-MZ5-671	001	\$502.46
04	COIL, IGNITION 30510-KT7-023	002	\$89.99
05	SPACER 30520-ML7-000	004	\$2.89
06	CAP ASSY. 30700-KAF-010	004	\$25.56
07	WIRE 1, IGNITION 30731-MZ5-000	001	\$19.87
08	CORD,HIGH/T 30731-KEA-505 (replaces 30732-MZ5-000)	001	\$19.87
09	CORD,HIGH/T 30731-KEA-505 (replaces 30733-MZ5-000)	001	\$19.87
10	CORD,HIGH/T 30731-KEA-505 (replaces 30734-MZ5-000)	001	\$19.87
11	RECTIFIER, REGULATE 31600-MZ5-003	001	\$203.22
12	RECTIFIER, SILICON 31700-196-000	001	\$20.76
13	WIRE HARNESS 32100-MZ5-670	001	\$409.25
14	HORN (LOW) 38120-MZ5-003	001	\$48.47
15	RELAY, TURN SIGNAL 38301-KK9-952	001	\$46.75

#	Description	Q'ty	Price
16	SUSPENSION 38306-GE7-000	001	\$3.71
17	INDICATOR UNIT 38710-MZ5-003	001	\$66.65
18	BRACKET, RR. 50333-MZ5-000	001	\$21.73
19	BRACKET, FR. 50334-MZ5-000	001	\$21.58
20	PLATE 50336-MR1-000	001	\$8.09
21	STRAP, CABLE (105MM) 90672-SB2-003	001	\$2.75
22	BOLT, HEX. (6X22) 92101-06022-4J	002	\$2.33
23	BOLT, HEX. (6X28) 92101-06028-4J	002	\$1.82
24	NUT, FLANGE (6MM) 94050-06070	002	\$0.73
25	NUT, FLANGE (6MM) 94050-06080	002	\$0.23
26	BOLT, FLANGE (8X12) 95701-08012-07	001	\$0.75
27	BOLT, FLANGE (6X12) 96001-06012-00	002	\$0.78
28	FUSE, BLADE (10A) 98200-31000	004	\$0.67
29	FUSE, BLADE (15A) 98200-31500	002	\$0.67

MEMO

24. Appendix: Gasket Diagrams

Alternator Cover Gasket	24-2
Cam Chain Tensioner Gaskets	24-3
Oil Pan Gasket	24-4
Right Crankcase Cover Gasket	24-5
Shift Cover Gasket	24-6
Sprocket Cover Gasket	24-7

NOTE

- **Diagrams must be printed without using any scaling to fit paper.**
- **Some of the diagrams must be printed on larger than letter sized paper, or must be pieced together using the guides included on the images**

Alternator Cover Gasket

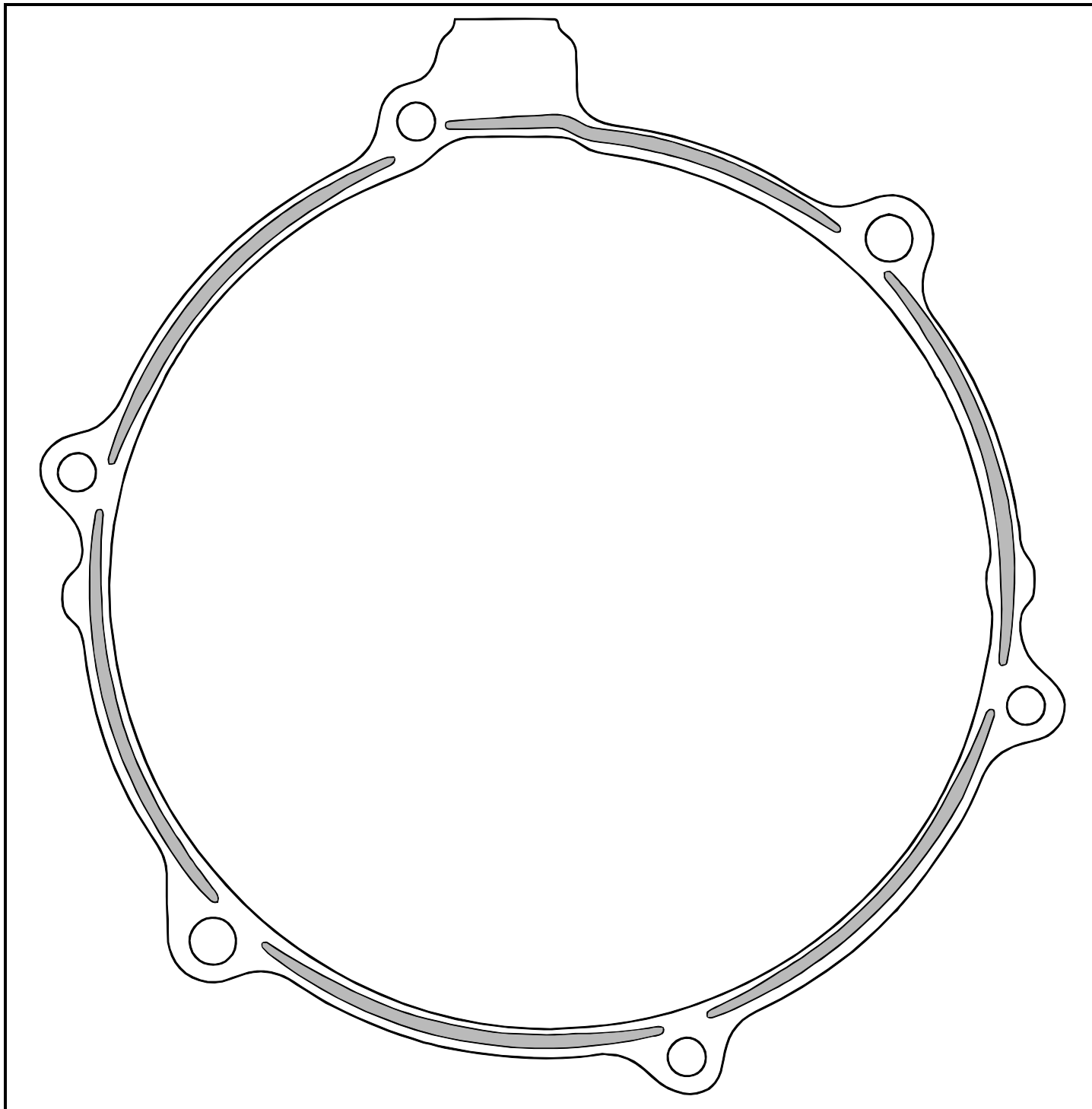

Description	Part Number
Alternator Cover Gasket	11636-MY7-000
Material	Thickness
Paper	0.0218"

NOTE

- Grey area is a thin bead of sealant

Cam Chain Tensioner Gaskets

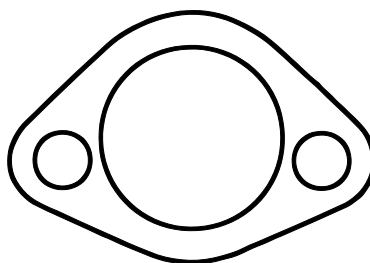
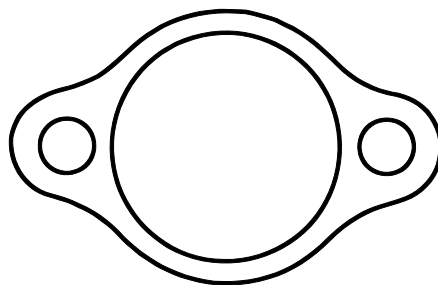

Description	Part Number
Cam Chain Tensioner Gasket - Front	12194-KW3-880
Cam Chain Tensioner Gasket - Rear	12194-HC5-740
Material	Thickness
Paper	0.0218"

Oil Pan Gasket

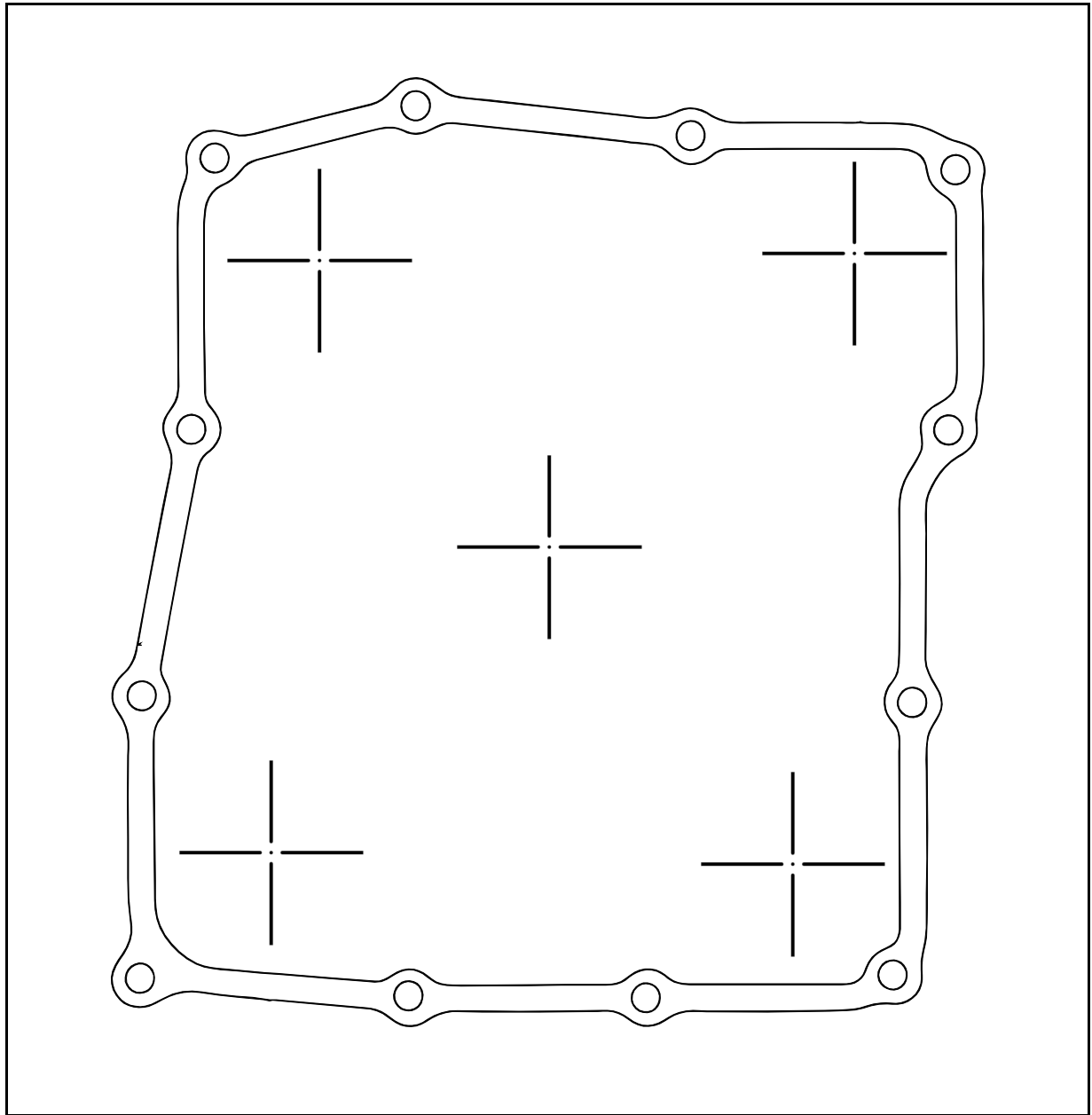

Description	Part Number
Oil Pan Gasket	11315-MY7-000
Material	Thickness
Paper	0.0218"

Right Crankcase Cover Gasket

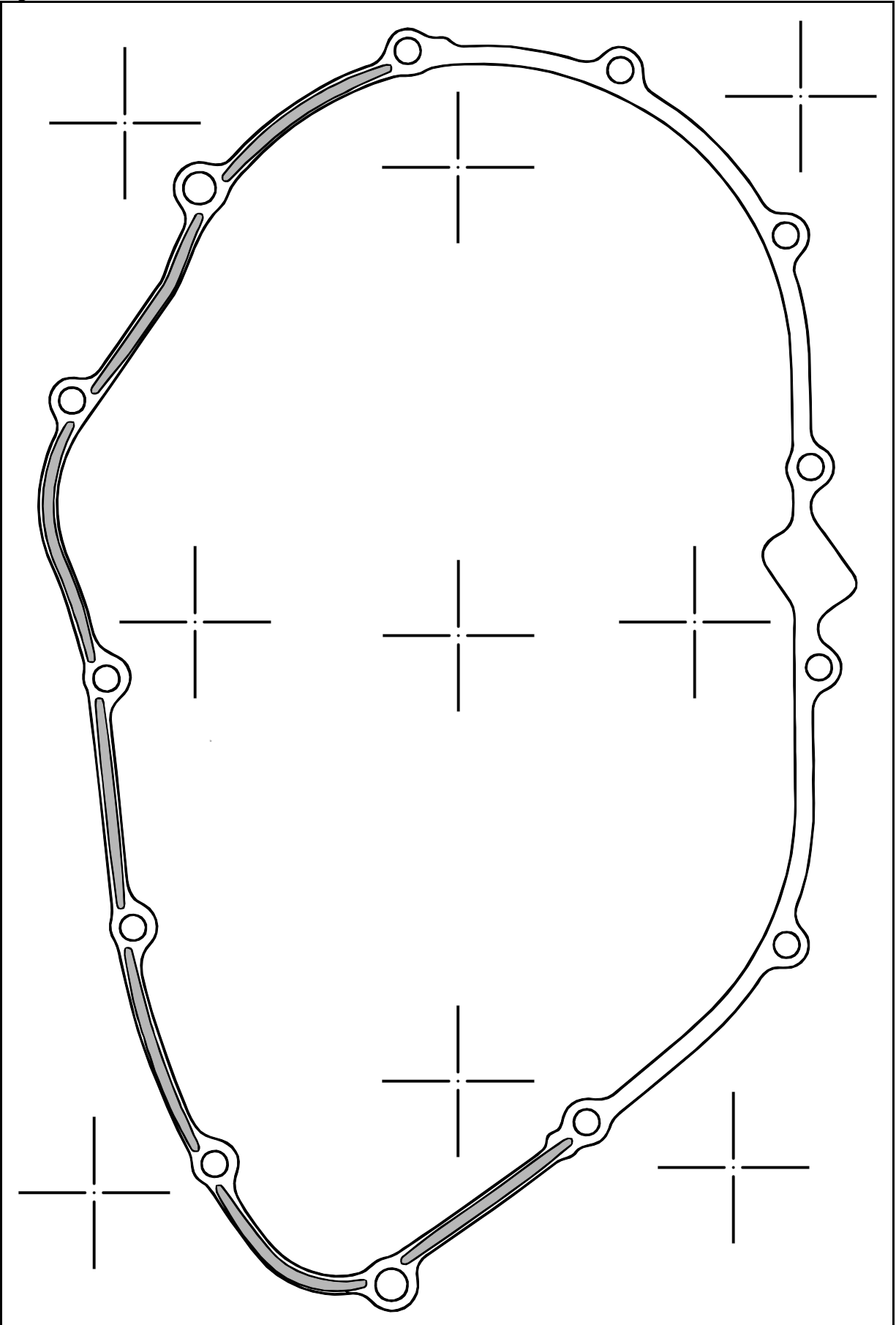

Description	Part Number
Right Crankcase Cover Gasket	11394-MY7-000
Material	Thickness
Paper	0.0218"

Shift Cover Gasket

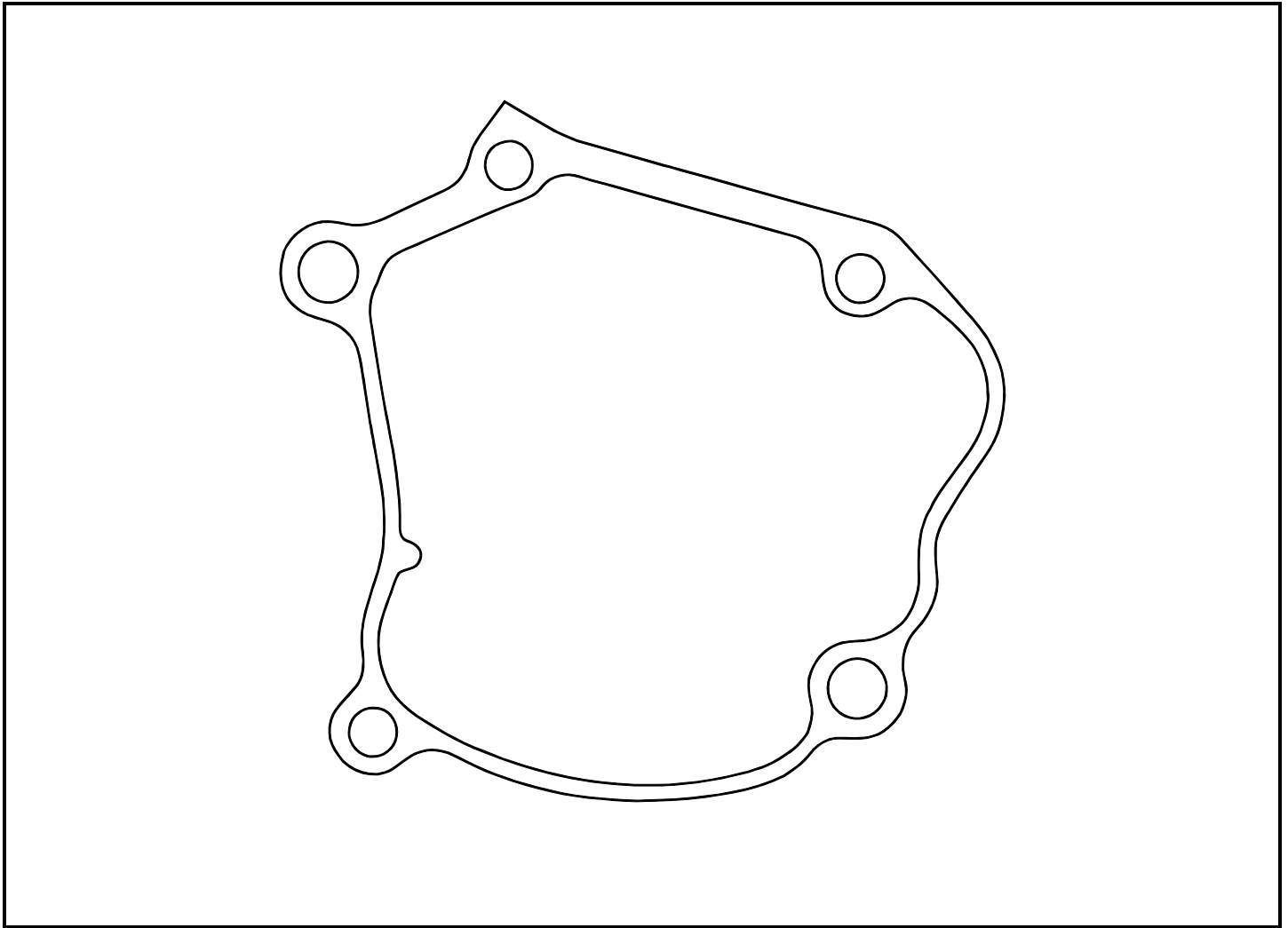

Description	Part Number
Shift Cover Gasket	11632-MY7-000
Material	Thickness
Paper	0.0218"

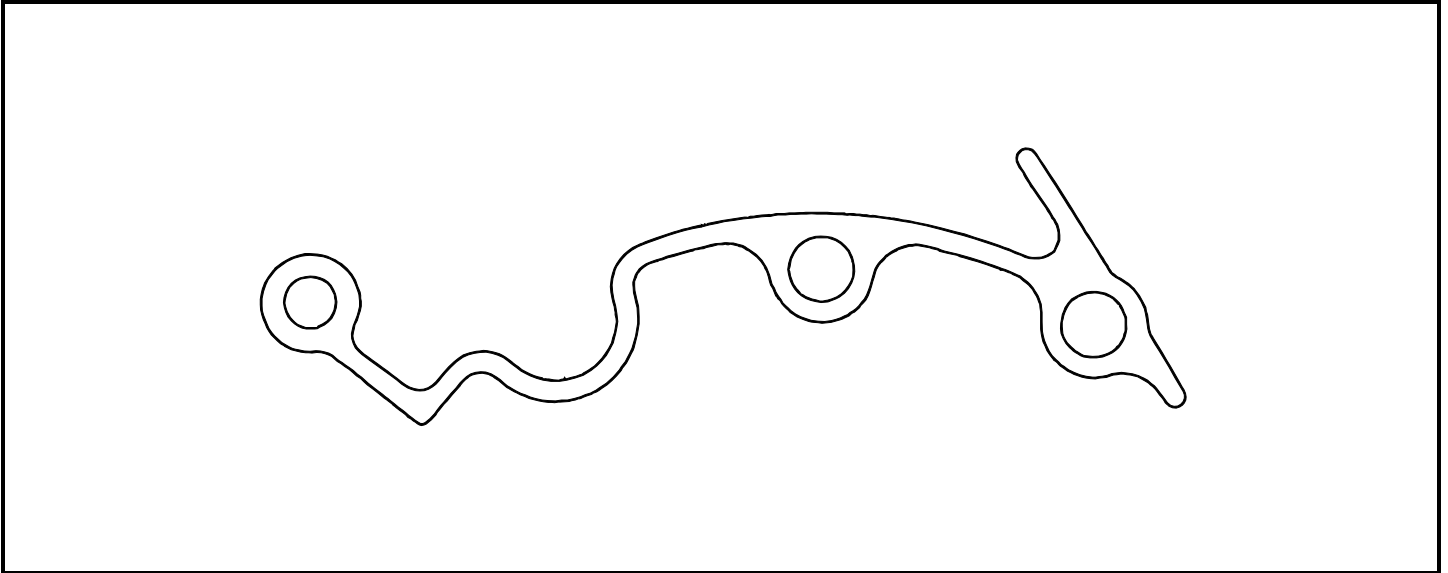
Sprocket Cover Gasket

Description	Part Number
Sprocket Cover Gasket	11343-MZ5-000
Material	Thickness
Paper	0.0218"

MEMO

