



**OWNER'S MANUAL**

**YAMAHA**

***XV1100E***

**3EG-28199-24**

EAA00100

**XV1100E**  
**OWNER'S MANUAL**  
**©1992 by Yamaha Motor Co., Ltd.**  
**1st Edition, September 1992**  
**All rights reserved. Any reprinting or**  
**unauthorized use without the written**  
**permission of Yamaha Motor Co., Ltd.**  
**is expressly prohibited.**  
**Printed in Japan**

## **INTRODUCTION**

Congratulations on your purchase of the Yamaha XV1100E. This model is the result of Yamaha's vast experience in the production of fine sporting, touring, and pace-setting racing machines. It represents the high degree of craftsmanship and reliability that have made Yamaha a leader in these fields.

This manual will give you an understanding of the operation, inspection, and basic maintenance of this motorcycle. If you have any questions about the operation or maintenance of your motorcycle, please consult a Yamaha dealer.

Particularly important information is distinguished in this manual by the following notations:



The Safety Alert Symbol means ATTENTION! BECOME ALERT! YOUR SAFETY IS INVOLVED!

### **WARNING**

Failure to follow **WARNING** instructions could result in severe injury or death to the motorcycle operator, a bystander or a person inspecting or repairing the motorcycle.

### **CAUTION**

A **CAUTION** indicates special precautions that must be taken to avoid damage to the motorcycle.

### **NOTE:**

A **NOTE** provides key information to make procedures easier or clearer.

**NOTE:** \_\_\_\_\_  
This manual should be considered a permanent part of this motorcycle and should remain with it even if the motorcycle is subsequently sold.

**NOTE:** \_\_\_\_\_  
Yamaha continually seeks advancements in product design and quality. Therefore, while this manual contains the most current product information available at the time of printing, there may be minor discrepancies between your machine and this manual. If there is any question concerning this manual, please consult your Yamaha dealer.

### **WARNING**

**PLEASE READ THIS MANUAL CAREFULLY AND COMPLETELY BEFORE OPERATING THIS MOTORCYCLE.**

# CONTENTS

SAFETY INFORMATION .....	1-1	Clutch lever .....	5-9
LOCATION OF THE IMPORTANT LABELS .....	2-1	Shift pedal .....	5-9
DESCRIPTION .....	3-1	Front brake lever .....	5-9
MOTORCYCLE IDENTIFICATION .....	4-1	Rear brake pedal.....	5-10
Identification numbers record.....	4-1	Fuel tank cap.....	5-10
Vehicle identification number .....	4-2	Starter lever (CHOKE) .....	5-10
Engine serial number.....	4-2	Steering lock.....	5-11
CONTROL FUNCTIONS .....	5-1	Helmet holder.....	5-12
Main switch.....	5-1	Front fork.....	5-13
Indicator lights .....	5-2	Rear shock absorber .....	5-13
Oil level indicator circuit check.....	5-3	Sidestand .....	5-14
Fuel level indicator circuit check.....	5-5	Sidestand/clutch switch operation check .....	5-15
Speedometer.....	5-6	PRE-OPERATION CHECKS.....	6-1
Tachometer .....	5-6	Brakes.....	6-3
Handlebar switches:.....	5-7	Brake fluid leakage .....	6-3
		Clutch.....	6-4
		Throttle grip .....	6-4
		Engine oil .....	6-4

Final gear oil.....	6-5
Tires.....	6-5
Tubeless tires and cast wheels.....	6-7
Fittings/Fasteners.....	6-9
Lights and signals.....	6-9
Switches .....	6-9
Battery.....	6-9
Fuel.....	6-10

## OPERATION AND IMPORTANT RIDING

POINTS .....	7-1
Starting and warming up a cold engine.....	7-1
Starting a warm engine .....	7-4
Shifting.....	7-4
Engine break-in .....	7-5
Parking .....	7-6

PERIODIC MAINTENANCE AND MINOR REPAIR .....	8-1
Tool kit.....	8-1
Periodic maintenance / Lubrication....	8-3
Torque specifications.....	8-5
Engine oil .....	8-6
Final gear oil .....	8-9
Air filter.....	8-11
Carburetor adjustment ..	8-13
Idle speed adjustment.....	8-13
Throttle cable adjustment ....	8-14
Valve clearance adjustment .....	8-15
Spark plug inspection .....	8-15
Front brake adjustment .....	8-17
Rear brake adjustment.....	8-18
Brake light switch adjustment.....	8-19
Checking the front brake pads and rear brake shoes .....	8-20
Inspecting the brake fluid level ....	8-20
Brake fluid replacement.....	8-22
Clutch adjustment .....	8-22
Mechanism adjustment.....	8-23

Cable inspection and lubrication .....	8-23
Throttle cable and grip lubrication ...	8-24
Brake and shift pedals.....	8-24
Brake and clutch levers.....	8-24
Center and sidestand .....	8-24
Rear suspension .....	8-25
Front fork inspection .....	8-25
Front fork adjustment.....	8-26
Rear shock absorber adjustment .....	8-27
Recommended combinations of the front fork and the rear shock absorber settings.....	8-29
Steering inspection.....	8-30
Wheel bearings.....	8-30
Battery.....	8-30
Replenishing the battery fluid .....	8-32
Fuse replacement .....	8-33
Headlight bulb replacement .....	8-34
Front wheel removal .....	8-36
Front wheel installation .....	8-37
Rear wheel removal .....	8-38
Rear wheel installation.....	8-40

Troubleshooting.....	8-41
Troubleshooting chart .....	8-42
CLEANING AND STORAGE .....	9-1
A. Cleaning.....	9-1
B. Storage.....	9-2
SPECIFICATIONS.....	10-1
NOISE REGULATION (FOR Australia)	11-1
WIRING DIAGRAM	

## **⚠ SAFETY INFORMATION**

**TWO-WHEELED MOTORCYCLES ARE SINGLE TRACK VEHICLES. THEIR SAFE USE AND OPERATION ARE DEPENDENT UPON THE USE OF PROPER RIDING TECHNIQUES AS WELL AS THE EXPERTISE OF THE OPERATOR. EVERY OPERATOR SHOULD KNOW THE FOLLOWING REQUIREMENTS BEFORE RIDING.**

**HE OR SHE SHOULD:**

- 1. OBTAIN THOROUGH INSTRUCTIONS FROM A COMPETENT SOURCE ON ALL ASPECTS OF MOTORCYCLE OPERATION.**
- 2. OBSERVE THE WARNINGS AND MAINTENANCE REQUIREMENTS IN THE OWNER'S MANUAL.**
- 3. OBTAIN QUALIFIED TRAINING IN SAFE AND PROPER RIDING TECHNIQUES.**
- 4. OBTAIN PROFESSIONAL TECHNICAL SERVICE AS INDICATED BY THE OWNER'S MANUAL AND/OR WHEN MADE NECESSARY BY MECHANICAL CONDITIONS.**

## **SAFE RIDING**

- 1. Always make pre-operation checks. Careful checks may help prevent an accident.**
- 2. This motorcycle is designed to carry the operator and a passenger.**



**3. The failure of motorists to detect and recognize motorcycles in traffic is the predominating cause of automobile/motorcycle accidents. Many accidents have been caused by an automobile driver who did not see the motorcycle. Making yourself conspicuous appears to be very effective in reducing the chance of this type of accident.**

**Therefore:**

- a. Wear a brightly colored jacket.**
  - b. Use extra caution when you approach and pass through intersections, since intersections are the most likely places for motorcycle accidents.**
  - c. Ride where other motorists can see you. Avoid riding in another motorist's "blind spot."**
- 4. Many accidents involve inexperienced operators. In fact, many operators who have been involved in accidents do not even have a current motorcycle license.**
- a. Make sure you are qualified. Also, only lend your motorcycle to experienced operators.**
  - b. Know your skills and limits. Staying within your limits may help you to avoid an accident.**
  - c. We recommend that you practice riding your motorcycle where there is no traffic until you have become thoroughly familiar with your motorcycle and all of its controls.**

- 5. Many motorcycle accidents have been caused by motorcycle operator errors. A typical error made by the operator is veering wide on a turn due to EXCESSIVE SPEED or undercornering (insufficient lean angle for the speed).**
  - a. Always obey the speed limits and never travel faster than warranted by road and traffic conditions.**
  - b. Always signal before turning or changing lanes. Make sure other motorists see you.**
- 6. The operator's and passenger's posture are important for proper control.**
  - a. The operator should keep both hands on the handlebars and both feet on the operator footrests during operation to maintain control of the motorcycle.**
  - b. The passenger should always hold on to the operator, or the seat strap or grab bar if the motorcycle is so equipped, with both hands and keep both feet on the passenger footrests.**
  - c. Never carry a passenger unless he or she can firmly place both feet on the passenger footrests.**
- 7. Never ride under the influence of alcohol or drugs.**
- 8. This motorcycle is designed for on-road use only. It is not suitable for off-road use.**

## **PROTECTIVE APPAREL**

The majority of fatalities from motorcycle accidents are the result of head injuries. The use of a safety helmet is the single most critical factor in the prevention or reduction of head injuries.

1. Always wear an approved helmet.
2. Wear a face shield or goggles. Wind on your unprotected eyes could contribute to an impairment of vision which could delay seeing a hazard.
3. The use of heavy boots, jacket, trousers, gloves, etc. is effective in preventing or reducing abrasions or lacerations.
4. Never wear loose fitting clothing. It could catch on the control levers, footrests, or wheels and cause injury or accident.
5. Never touch the engine or exhaust system during or after operation. They become very hot and can cause burns. Always wear protective clothing that covers your legs, ankles, and feet.
6. A passenger should also observe the above precautions.

## **MODIFICATION**

**Modifications made to the motorcycle not approved by Yamaha, or the removal of original equipment, may render your motorcycle unsafe for use and may cause severe personal injury. Modifications may also make your motorcycle illegal to use.**

## **LOADING AND ACCESSORIES**

**Adding accessories or cargo to your motorcycle can adversely affect stability and handling if the weight distribution of the machine is changed. To avoid the possibility of an accident, extreme caution should be used if adding cargo or accessories to your motorcycle. Use extra care if riding a motorcycle which has added cargo or accessories. Here are some general guidelines to follow if loading cargo or adding accessories to your motorcycle:**

### **LOADING**

**The total weight of the operator, passenger, accessories and cargo must not exceed the maximum load limit of 509 lbs. (231 kg).**

**When loading within these weight limits, keep the following in mind:**

- 1. Cargo and accessory weight should be kept as low and close to the motorcycle as possible. Be sure to distribute the weight as evenly as possible on both sides of the machine to minimize imbalance or instability.**
- 2. Shifting weights can create a sudden imbalance. Make sure that accessories and cargo are securely attached to the motorcycle before riding. Recheck accessory mounts and cargo restraints frequently.**
- 3. Never attach any large or heavy items to the handlebars, front forks, or front fender. These items, including such cargo as sleeping bags, duffle bags, or tents, can create unstable handling or slow steering response.**

## **ACCESSORIES**

**Genuine Yamaha accessories have been specifically designed for use on this motorcycle. Since Yamaha cannot test all other accessories which may be available, you must personally be responsible for the proper selection, installation and use of non-Yamaha accessories. You should use extreme caution when selecting and installing any accessories.**

**Keep in mind these guidelines for mounting accessories in addition to those provided under "LOADING."**

- 1. Never install accessories or carry cargo that would impair the performance of your motorcycle. Carefully inspect the accessory before using it to make sure it does not in any way reduce ground clearance or cornering clearance, limit suspension travel, steering travel or control operation, or obscure lights or reflectors.**
  - a. Accessories fitted to the handlebar or the front fork area can create instability due to improper weight distribution or aerodynamic changes. If accessories are added to the handlebar or front fork area, they must be as lightweight as possible and should be kept to a minimum.**
  - b. Bulky or large accessories may seriously affect the stability of the motorcycle due to aerodynamic effects. Wind may attempt to lift the motorcycle, or the motorcycle may become unstable in cross winds. These accessories may also cause instability when being passed by or passing large vehicles.**
  - c. Certain accessories can displace the operator from his or her normal riding position. This improper position limits the freedom of movement of the operator and may limit control ability. Therefore such accessories are not recommended.**
- 2. Caution must be used if adding electrical accessories. If these accessories exceed the capacity of the motorcycle's electrical system, an electric failure could result, which could cause a dangerous loss of lights or engine power.**

## **GASOLINE AND EXHAUST GAS**

- 1. GASOLINE IS HIGHLY FLAMMABLE:**
  - a. Always turn off the engine when refueling.**
  - b. Take care not to spill any gasoline on the engine or exhaust pipe(s)/muffler(s) when refueling.**
  - c. Never refuel while smoking or in the vicinity of an open flame.**
- 2. Never start the engine or let it run for any length of time in a closed area. The exhaust fumes are poisonous and may cause loss of consciousness and death within a short time. Always operate your motorcycle in an area that has adequate ventilation.**
- 3. Always turn off the engine before leaving the motorcycle unattended and remove the ignition key. When parking the motorcycle, note the following:**
  - a. The engine and exhaust pipe(s)/muffler(s) may be hot. Park the motorcycle in a place where pedestrians or children are not likely to touch these hot areas.**
  - b. Do not park the motorcycle on a slope or soft ground; the motorcycle may fall over.**
  - c. Do not park the motorcycle near a flammable source, e.g. a kerosene heater, or near an open flame. The motorcycle could catch fire.**

- 4. When transporting the motorcycle in another vehicle, be sure it is kept upright. If it should lean over, gasoline may leak out of the carburetor or fuel tank.**
- 5. If you should swallow any gasoline, inhale a lot of gasoline vapor, or allow gasoline to get in your eye(s), see your doctor immediately. If any gasoline spills on your skin or clothing, immediately wash it off with soap and water and change your clothes.**



## LOCATION OF THE IMPORTANT LABELS

Please read the following labels carefully before operating this motorcycle

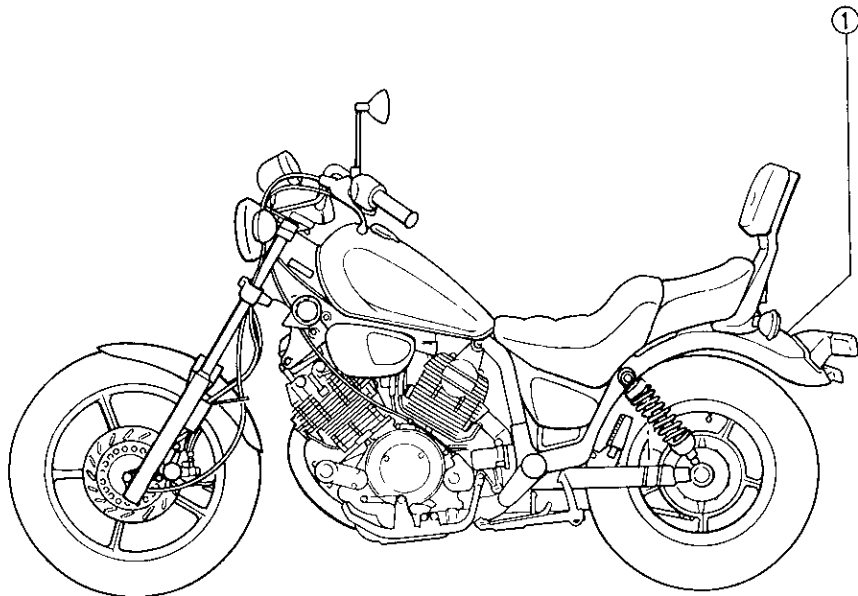

①

**WARNING**

**BEFORE YOU OPERATE THIS VEHICLE, READ  
THE OWNER'S MANUAL AND ALL LABELS.**

3HP-21568-00

## DESCRIPTION

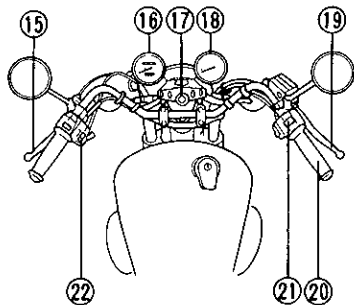
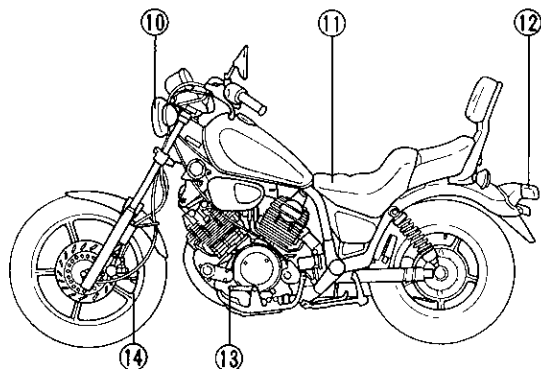
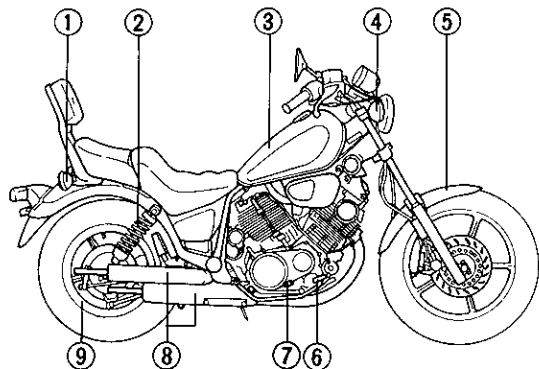

- |                       |                           |
|-----------------------|---------------------------|
| 1 Rear flasher light  | 12 Tail/Brake light       |
| 2 Rear shock absorber | 13 Shift pedal            |
| 3 Fuel tank           | 14 Front wheel            |
| 4 Front flasher light | 15 Clutch lever           |
| 5 Front fender        | 16 Speedometer            |
| 6 Brake pedal         | 17 Main switch            |
| 7 Footrest            | 18 Tachometer             |
| 8 Silencer            | 19 Brake lever            |
| 9 Rear wheel          | 20 Throttle grip          |
| 10 Headlight          | 21 Right handlebar switch |
| 11 Seat               | 22 Left handlebar switch  |

## MOTORCYCLE IDENTIFICATION

EAA60800

### Identification numbers record

1. KEY IDENTIFICATION NUMBER:

2. VEHICLE IDENTIFICATION NUMBER:  
FRAME SERIAL NUMBER:

3. ENGINE SERIAL NUMBER:

Your key identification number is stamped on your key as shown in the following illustration. Record this number in the space provided for reference if you need a new key.

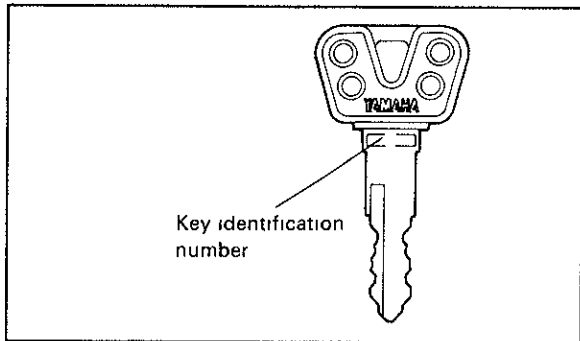

Record your vehicle identification number (or frame serial number) and engine serial number in the spaces provided to assist you in ordering spare parts from your Yamaha dealer or for reference in case your vehicle is stolen.

**Vehicle identification number**

The vehicle identification number is stamped into the steering head pipe.

EUU00400

**NOTE:**

The vehicle identification number is used to identify your motorcycle and may be used to register your motorcycle with the licensing authority in your state.

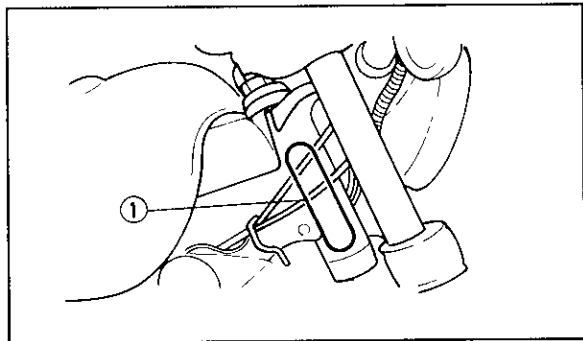

1 Vehicle identification number

**Engine serial number**

The engine serial number is stamped into the crankcase.

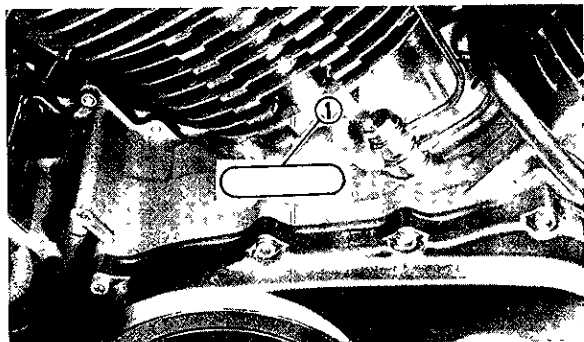

1 Engine serial number

EUU00300

**NOTE:**

The first three digits of these numbers are for model identification, the remaining digits are the unit production number. Keep a record of these numbers for reference when ordering parts from a Yamaha dealer.

## CONTROL FUNCTIONS

### Main switch

The main switch controls the ignition and lighting systems. Its operation is described below.

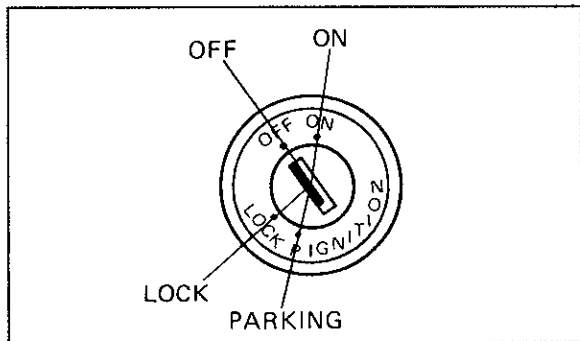

### ON:

Electrical circuits are switched on, and the headlight, meter light, and taillight come on. The engine can be started. The key cannot be removed in this position.

### OFF:

All electrical circuits are switched off. The key can be removed in this position.

### LOCK:

The steering is locked in this position, and all electrical circuits are switched off. The key can be removed in this position. Refer to "Steering lock" (page 5-11) for operation instructions.

### PARKING:

The steering is locked in this position, and the taillight comes on but all other circuits are off. The key can be removed in this position.

### NOTE:

Always turn the main switch to "OFF" or "LOCK" and remove the key when the motorcycle is unattended.

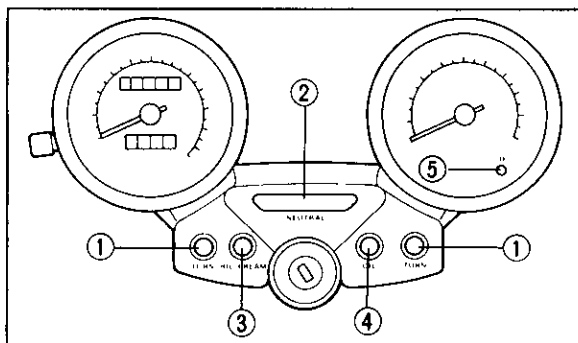
**Indicator lights**

- 1 "TURN" indicator light
- 2 "NEUTRAL" indicator light
- 3 "HIGH BEAM" indicator light
- 4 "OIL LEVEL" indicator light
- 5 "FUEL" level indicator light

EAB10100

**"TURN" indicator light (orange):**

This indicator flashes when the turn switch is "ON".

EAB10200

**"NEUTRAL" indicator light (green):**

This indicator comes on when the transmission is in neutral.

EAB10300

**"HIGH BEAM" indicator light (blue):**

This indicator comes on when the headlight high beam is used.

EAB10600

**"OIL LEVEL" indicator light (red):**

This indicator comes on when the oil level is low. This light circuit can be checked by the following procedure.

EUU30000

**CAUTION:**

**Do not run the motorcycle until you know it has sufficient engine oil.**

## Oil level indicator circuit check

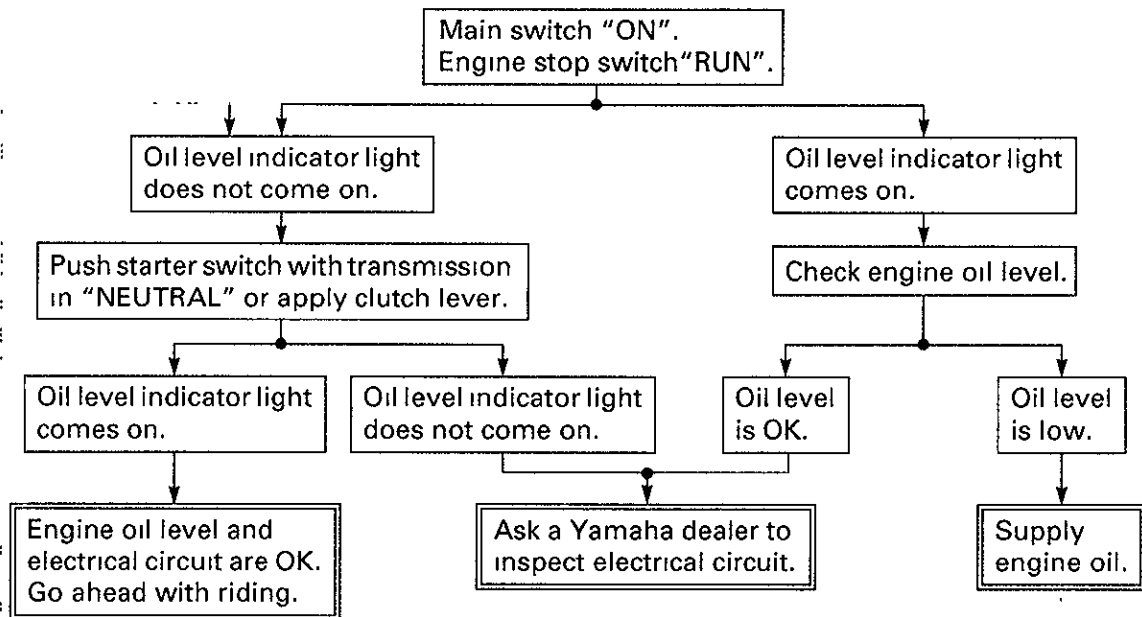



**“FUEL” level indicator light (red):**

When the fuel level drops below approximately 3.0 L (0.7 Imp gal, 0.8 US gal), this light will come on. When this light comes on, slide the “FUEL” (Reserve) switch to “RES”. Then, fill the tank at the first opportunity.

## Fuel level indicator circuit check

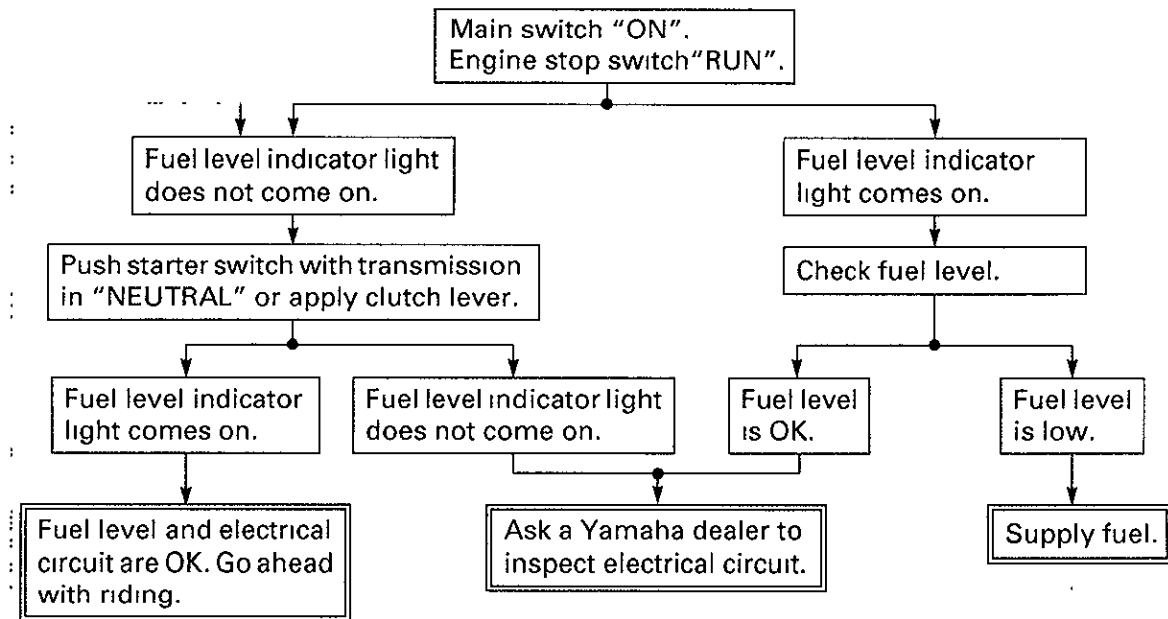

## Speedometer

The speedometer shows riding speed. This speedometer is equipped with an odometer and trip odometer. The trip odometer can be reset to "0" with the reset knob. Use the odometer to estimate how far you can ride on a tank of fuel before going to "RESERVE". This information will enable you to plan fuel stops in the future.

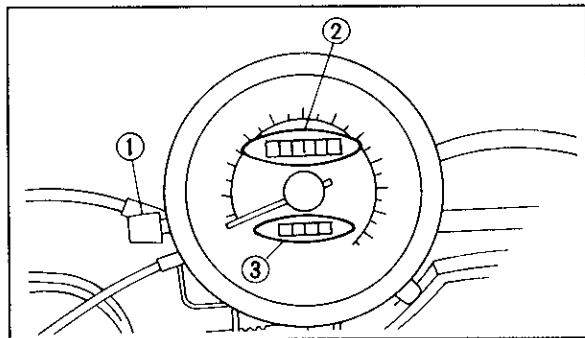

1 Reset knob    2 Odometer    3 Trip odometer

## Tachometer

This model is equipped with an electric tachometer so the rider can monitor the engine speed and keep it within the ideal power range.

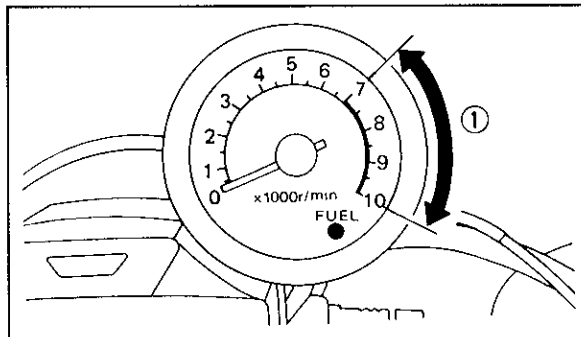

1 Red zone

EUU30400

### CAUTION:

**Do not operate in the red zone**  
**Red zone: 7,000 r/min and above**

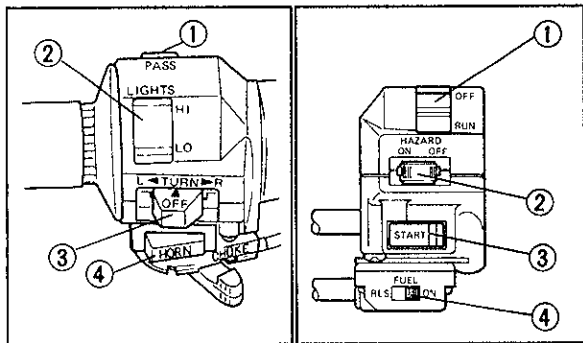
**Handlebar switches:**

- |                             |                           |
|-----------------------------|---------------------------|
| 1 "PASS" switch             | 1 "ENGINE STOP" switch    |
| 2. "LIGHTS" (Dimmer) switch | 2 "HAZARD" switch         |
| 3 "TURN" signal switch      | 3 "START" switch          |
| 4 "HORN" switch             | 4 "FUEL" (Reserve) switch |

**"PASS" switch**

Before passing a vehicle ahead, the passing light switch should be depressed so that the headlight gives a signal to the driver of the other vehicle.

**"LIGHTS" (Dimmer) switch**

Turn the switch to "HI" for the high beam and to "LO" for the low beam.

**"TURN" signal switch**

This model is equipped with self-canceling turn signals. To signal a right-hand turn, push the switch to the right; to signal a left-hand turn, push the switch to the left. Once the switch is released it will return to the center position. To cancel the signal, push the switch in after it has returned to the center position. If the switch is not cancelled by hand, it will self-cancel after the motorcycle has travelled for about 10 seconds or approximately 150 meters (490 feet) whichever is greater. The self-canceling mechanism only operates when the motorcycle is moving; thus the signal will not self-cancel while you are stopped at an intersection.

EAB60200

### **"HORN" switch**

Press the switch to sound the horn

EAB60901

### **"ENGINE STOP" switch**

The engine stop switch is a safety device for use in an emergency such as when the motorcycle overturns or if trouble occurs in the throttle system. Turn the switch to "RUN" to start the engine. In case of emergency, turn the switch to "OFF" to stop the engine.

EAB60701

### **"START" switch**

The starter motor cranks the engine when pushing the starter switch.

EUU30700

### **CAUTION:** \_\_\_\_\_

**See starting instructions prior to starting the engine.**

---

EAB60601

### **"HAZARD" switch**

The hazard lights should be used under emergency or hazardous conditions. Both front and rear flasher lights will flash simultaneously, when this switch is turned on

EUU30601

### **CAUTION:** \_\_\_\_\_

**Always turn the main switch to "OFF" or "PARKING" while the "HAZARD" switch is on. The battery can discharge from extended use of the hazard lights.**

---

EUU01100

### **NOTE:** \_\_\_\_\_

Turn on the hazard lights to warn other drivers if your motorcycle must be stopped where it might be a traffic hazard.

---

**"FUEL" (Reserve) switch**

This switch should usually be kept in the "ON" position while riding. When the fuel level indicator light comes on, turn the switch to "RES" and refuel at the first opportunity. Then turn the switch to "ON".

**NOTE:**

When the switch is turned to "RES", about 3.0 L (0.7 Imp gal, 0.8 US gal) remain in the fuel tank.

**Clutch lever**

The clutch lever is located on the left handlebar, and the starting circuit cutoff switch is incorporated in the clutch lever holder. Pull the clutch lever to the handlebar to disengage the clutch, and release the lever to engage the clutch. The lever should be pulled rapidly and released slowly for smooth clutch operation. (Refer to the engine starting procedures for a description of the starting circuit cutoff switch.)

**Shift pedal**

This motorcycle is equipped with a constant-mesh 5-speed transmission. The shift pedal is located on the left side of the engine and is used in combination with the clutch when shifting.

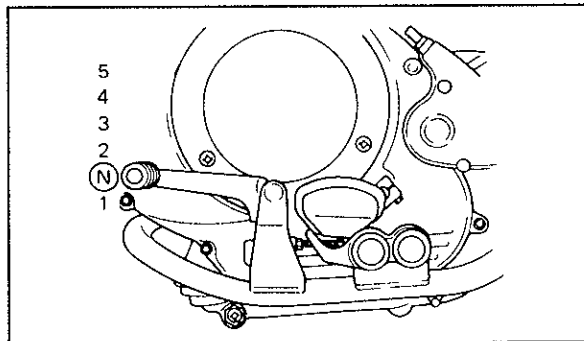

N Neutral

**Front brake lever**

The front brake lever is located on the right handlebar. Pull it toward the handlebar to apply the front brake.

## Rear brake pedal

The rear brake pedal is on the right side of the motorcycle. Press down on the brake pedal to apply the rear brake.

## Fuel tank cap

TO OPEN:

Insert the key and turn it 1/4 turn clockwise. The lock will be released and the cap can be opened.

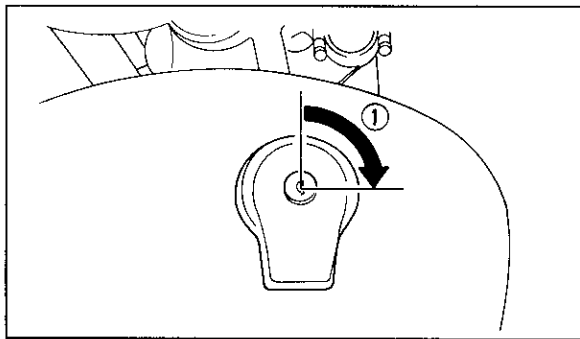

1 Open

TO CLOSE:

Push the tank cap into position with the key inserted. To remove the key, turn it counterclockwise to the original position.

**NOTE:**

This tank cap cannot be closed unless the key is in the lock. The key cannot be removed if the cap is not locked properly.

## **⚠ WARNING**

**Be sure the cap is properly installed and locked in place before riding the motorcycle.**

## Starter lever (CHOKE)

The starter lever is located on the left handlebar. Starting a cold engine requires a richer fuel mixture. In such a case, turn the starter lever to the left. After the engine is warm, turn the lever to its original position.

## Steering lock

The steering is locked when the main switch is turned to "LOCK." To lock the steering, turn the handlebars all the way to the left or right. With the key at "OFF," push it into the main switch and release it, turn it counterclockwise to "LOCK," and remove it. To release the lock, turn the key to "OFF".

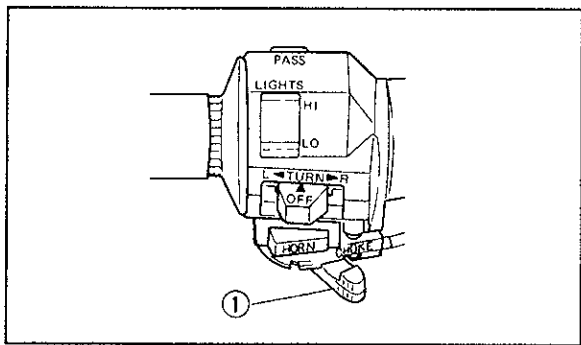

1 Starter lever

EUU01600

### NOTE:

Refer to "Starting and warming up a cold engine" for proper operation.

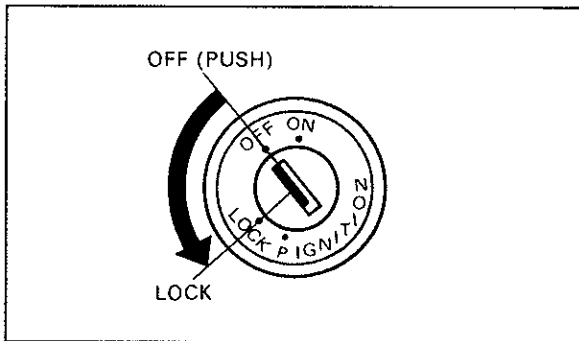



**Helmet holder**

To open the helmet holder, insert the key in the lock and turn it as shown. To lock the helmet holder, replace the holder in its original position.

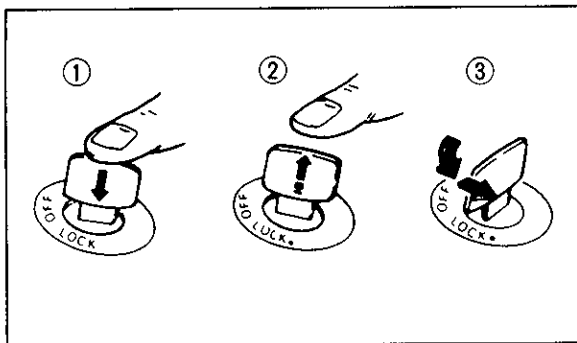

1 Push

2 Release

3 Turn

EUU61400

**⚠ WARNING**

Never turn the key to "LOCK" when the motorcycle is moving.

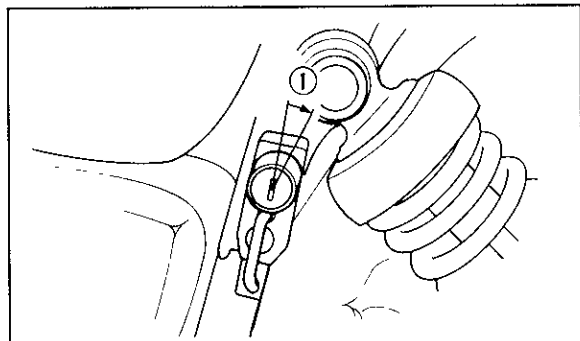

1 Open

EUU72900

**⚠ WARNING**

Never ride with a helmet in the helmet holder. The helmet may hit objects, causing loss of control and possibly an accident.

## Front fork

The front fork has a combination air and mechanical coil spring in the inner tubes.

By adjusting the air pressure, you can alter the suspension to suit the motorcycle's load (ex : optional accessories etc.) and the road conditions.

Refer to page 8-26 for proper adjustment procedures.



## Rear shock absorber

The spring preload and the damping force of the rear shock absorber can be adjusted to suit the rider's preference, motorcycle's load (ex: optional accessories etc.) and riding conditions. Refer to page 8-27 for proper adjustment procedures.

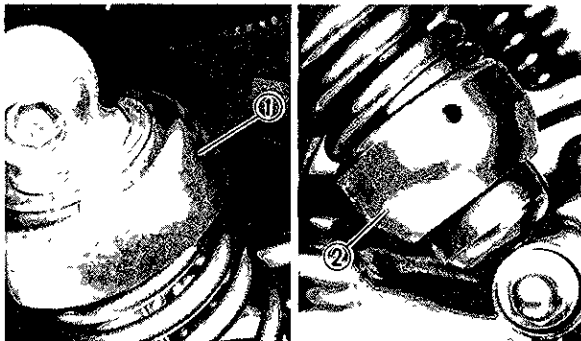

1. Damping adjuster

2. Spring preload adjuster

## Sidestand

This model is equipped with an ignition circuit cut-off system. The motorcycle must not be ridden when the sidestand is down. The sidestand is located on the left side of the frame. (Refer to page 7-1 for an explanation of this system.)

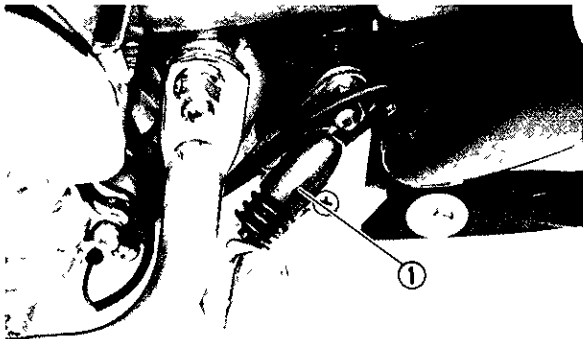

1 Sidestand switch

## **⚠ WARNING**

**This motorcycle must not be operated with the sidestand in the down position. If the stand is not properly retracted, it could contact the ground and distract the operator, resulting in a possible loss of control. Yamaha has designed into this motorcycle a lockout system to assist the operator in fulfilling the responsibility of retracting the sidestand. Please check carefully the operating instructions listed below and if there is any indication of a malfunction, return the motorcycle to a Yamaha dealer immediately for repair.**

**Sidestand/clutch switch operation check**

Check the operation of the sidestand switch and clutch switch against the information below.

EUU69000

**⚠ WARNING**

**Be sure to use the centerstand during this inspection.**

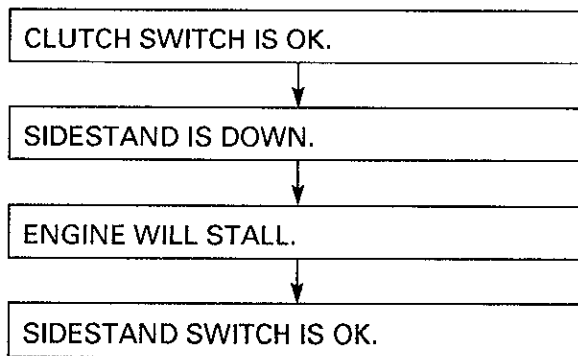
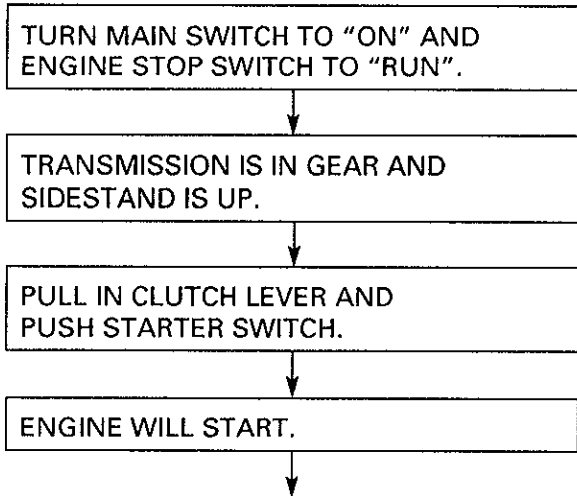

EUU69100

**⚠ WARNING**

**If improper operation is noted, consult a Yamaha dealer immediately.**

## PRE-OPERATION CHECKS

Before using this motorcycle, check the following points:

Item	Routine	Page
Front brake	Check operation, free play, fluid level and fluid leakage. Top-up with DOT#4 (or DOT#3) brake fluid if necessary	6-3~6-4, 8-17~8-22
Rear brake	Check operation, condition and free play. Adjust if necessary	
Clutch	Check operation, condition and free play. Adjust if necessary	6-4, 8-22
Throttle grip/housing	Check for smooth operation Lubricate/Adjust if necessary	6-4, 8-14~8-15, 8-24
Engine oil	Check oil level/add oil as required	6-4, 8-6~8-9
Final gear oil	Check for leakage visually.	6-5, 8-9~8-11
Wheels/Tires	Check tire pressure, wear and damage.	6-5~6-9, 8-36~8-40
Control/Meter cables	Check for smooth operation. Lubricate if necessary.	8-23~8-24
Brake and shift pedal shafts	Check for smooth operation Lubricate if necessary.	8-24
Brake and clutch lever pivots	Check for smooth operation. Lubricate if necessary	8-24
Center and sidestand pivots	Check for smooth operation Lubricate if necessary	8-24

Item	Routine	Page
Fittings/fasteners	Check all chassis fittings and fasteners Tighten/Adjust if necessary	6-9, 8-5
Fuel tank	Check fuel level/top-up as required	6-10
Lights and signals	Check for proper operation.	6-9, 8-34~8-36
Battery	Check fluid level, top-up with distilled water if necessary.	6-9, 8-30~8-32

**NOTE:**

Pre-operation checks should be made each time the motorcycle is used. Such an inspection can be thoroughly accomplished in a very short time, and the added safety it assures is more than worth the time involved.

**⚠ WARNING**

If any item in the Pre-Operation Check is not working properly, have it inspected and repaired before operating the motorcycle.

**Brakes (See page 8-17 for details)**

1. Brake lever and brake pedal  
Check for correct free play in the front brake lever and rear brake pedal and adjust if necessary. Make sure the brakes are working properly by checking at low speed shortly after starting out.

EUU62300

**⚠ WARNING**

**A soft, spongy feeling in the brake lever indicates a failure in the brake system. Do not operate the motorcycle until the failure in the brake system is corrected. Ask a Yamaha dealer for immediate repairs. A soft, spongy feeling could indicate a hazardous condition in the brake system.**

2. Brake fluid  
Check the brake fluid level. Add fluid if necessary.

Recommended brake fluid: DOT #4
---------------------------------

**NOTE:** \_\_\_\_\_  
If DOT #4 is not available, #3 can be used.

3. Check the disc pads.  
Refer to page 8-20.
4. Check the brake shoes.  
Refer to page 8-20.

EUU02201

**NOTE:** \_\_\_\_\_  
When this brake service is necessary, consult a Yamaha dealer.

EAE11301

**Brake fluid leakage (Front)**

Apply the brake for a few minutes. Check to see if any brake fluid leaks out from the pipe joints or the master cylinder(s).

EUU37801

**CAUTION:** \_\_\_\_\_

**Brake fluid may deteriorate painted surfaces or plastic parts. Never spill any fluid. If spilled, clean it up immediately.**

**⚠ WARNING**

If brake fluid leakage is found, ask a Yamaha dealer for immediate repairs. Such leakage could indicate a hazardous condition.

**Clutch (See page 8-22 for details)**

Check the free play in the clutch lever, and make sure the lever operates properly. If the free play is incorrect, adjust it.

**Throttle grip (See page 8-14 for details)**

Turn the throttle grip to see if it operates properly, and check the free play. Make sure the grip returns by spring force when released. Ask a Yamaha dealer to make any necessary adjustments.

**Engine oil (See page 8-6 for details)**

Make sure the engine oil is at the specified level. Add oil as necessary.

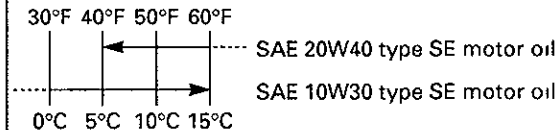
**Recommended oil:****Oil quantity:**

Total amount:

3.6 L (3.2 Imp qt, 3.8 US qt)

Periodic oil change:

3.0 L (2.6 Imp qt, 3.2 US qt)

With oil filter replacement:

3.1 L (2.7 Imp qt, 3.3 US qt)

**NOTE:**

Recommended engine oil classification; API Service "SE", "SF" type or equivalent (e.g. "SF-SE", "SF-SE-CC", "SF-SE-SD" etc.).



**Final gear oil (See page 8-9 for details)**

Make sure the final gear oil is at the specified level. Add oil as necessary.

Recommended oil:

SAE 80 API GL-4 Hypoid gear oil

If desired, an SAE 80W90 hypoid gear oil may be used for all conditions.

**NOTE:**

"GL-4" is a quality and additive rating. "GL-5" or "GL-6" rated hypoid gear oils may also be used.

**Tires**

To ensure maximum performance, long service, and safe operation, note the following:

1. Tire air pressure

Always check and adjust the tire pressure before operating the motorcycle

**⚠ WARNING**

**Tire inflation pressure should be checked and adjusted when the temperature of the tire equals the ambient air temperature. Tire inflation pressure must be adjusted according to total weight of cargo, rider, passenger, and accessories (fairing, saddlebags, etc. if approved for this model), and vehicle speed.**

Basic weight With oil and full fuel tank	239 kg (527 lbs)	
Maximum load*	231 kg (509 lbs)	
Cold tire pressure	Front	Rear
Up to 90 kg (198 lbs) load*	200 kPa (2 00 kgf/cm <sup>2</sup> , 29 psi)	225 kPa (2 25 kgf/cm <sup>2</sup> , 33 psi)
90 kg (198 lbs) load ~ Maximum load*	200 kPa (2 00 kgf/cm <sup>2</sup> , 29 psi)	250 kPa (2 50 kgf/cm <sup>2</sup> , 36 psi)
High speed riding	200 kPa (2 00 kgf/cm <sup>2</sup> , 29 psi)	250 kPa (2 50 kgf/cm <sup>2</sup> , 36 psi)

\* Load is the total weight of cargo, rider, passenger, and accessories

**⚠ WARNING**

Proper loading of your motorcycle is important for several characteristics of your motorcycle; such as handling, braking, performance and safety. Do not carry loosely packed items that can shift. Securely pack your heaviest items close to the center of the motorcycle, and distribute the weight evenly from side to side. Properly adjust the suspension for your load, and check the condition and pressure of your tires. **NEVER OVERLOAD YOUR MOTORCYCLE.** Make sure the total weight of the cargo, rider, passenger, and accessories (fairing, saddlebags, etc. if approved for this model) does not exceed the maximum load of the motorcycle. Operation of an overloaded motorcycle could cause tire damage, an accident, or even injury.

## 2. Tire inspection

Always check the tires before operating the motorcycle. If a tire tread shows crosswise lines (minimum tread depth), if the tire has a nail or glass fragments in it, or if the side wall is cracked, contact a Yamaha dealer immediately and have the tire replaced.

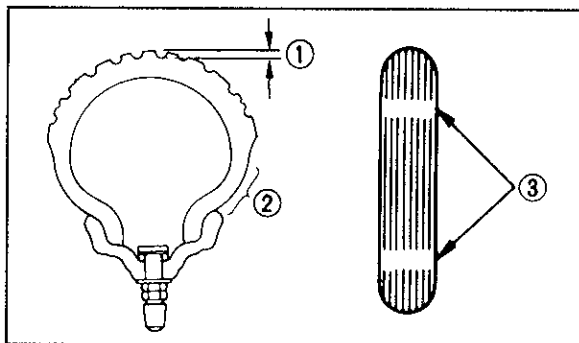

1 Tread depth      2 Side wall      3 Wear indicator

## FRONT

Manufacture	Size	Type
Bridgestone	100/90-19 57H	G535
Dunlop	100/90-19 57H	F17

## REAR

Manufacture	Size	Type
Bridgestone	140/90-15M/C 70H	G536
Dunlop	140/90-15M/C 70H	K425

Minimum tire tread depth (front and rear)	1.0 mm (0.04 in)
--	------------------

EUU67900

**⚠ WARNING**

It is dangerous to ride with a worn-out tire. When a tire tread begins to show lines, have a Yamaha dealer replace the tire immediately. Brakes, tires, and related wheel parts replacement should be left to a Yamaha Service Technician.

EAE93800

**Tubeless tires and cast wheels**

This motorcycle is equipped with cast wheels designed for either tube-type or tubeless tires. Tubeless tires are installed as standard equipment.

EUU68600

**⚠ WARNING**

Do not attempt to use tubeless tires on a wheel designed for use only with tube-type tires. Tire failure and personal injury may result from sudden deflation.

Tubeless-type → Wheel Tubeless or Tube-type Tires Tube Wheel → Tube-type Tires only
--

EUU68700

**⚠ WARNING**

When using tube-type tires, be sure to install the proper tube also.

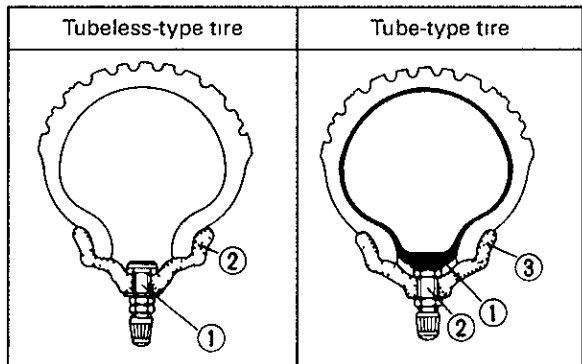
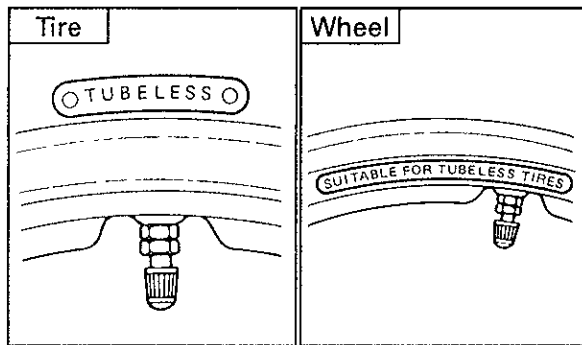

- 1 Air valve  
2 Cast wheel

- 1 Tube  
2 Air valve  
3 Cast wheel

To ensure maximum performance, long service, and safe operation, note the following:

1. Always inspect the wheels before a ride. Check for cracks, bends, or warpage of the wheels. If any abnormal condition exists in a wheel, consult a Yamaha dealer. Do not attempt even small repairs to the wheel. If a wheel is deformed or cracked, it must be replaced.
2. Tires and wheels should be balanced whenever either one is changed or replaced. Failure to have a wheel balanced can result in poor performance, adverse handling characteristics, and shortened tire life.

3. After installing a tire, ride conservatively to allow the tire to seat itself on the rim properly. Failure to allow proper seating may cause tire failure, resulting in damage to the motorcycle and injury to the rider.
4. After repairing or replacing a tire, check to be sure the valve stem lock nut is securely fastened. If not, torque is as specified.

Tightening torque: 1.5 Nm (0.15 m·kg, 1.1 ft·lb)
---

EAE85000

### **Fittings/Fasteners**

Always check the tightness of chassis fittings and fasteners before a ride. Use the chart on page 8-5 to find the correct torque.

EAE70000

### **Lights and signals**

Check the headlight, flasher lights, tail-light, brake light, meter lights, and all the indicator lights to make sure they are in working condition.

EAE70700

### **Switches**

Check the operation of the headlight switch, turn switch, brake light switch, horn switch, starter switch, main switch, etc.

EAE70500

### **Battery (See page 8-30 for details)**

Check the fluid level and top-up if necessary. Use only distilled water if refilling is necessary.

**Fuel**

Make sure there is sufficient fuel in the tank.

**⚠ WARNING**

Do not overfill the fuel tank. Avoid spilling fuel on the hot engine. Do not fill the fuel tank above the bottom of the filler tube as shown in the illustration or it may overflow when the fuel heats up later and expands.

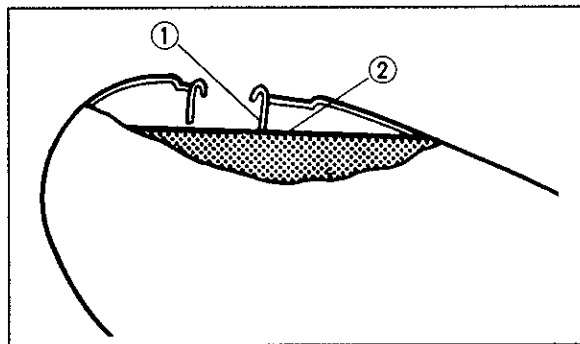

1 Filler tube

2 Fuel level

**CAUTION**

Always wipe off spilled fuel immediately with a dry and clean soft cloth. Fuel may deteriorate painted surfaces or plastic parts.

Recommended fuel:

Regular gasoline

For Australia:

Unleaded fuel only

Fuel tank capacity:

Total:

16.8 L (3.7 Imp gal, 4.4 US gal)

Reserve:

3.0 L (0.7 Imp gal, 0.8 US gal)

## OPERATION AND IMPORTANT RIDING POINTS

EUU67200

### WARNING

Before riding this motorcycle, become thoroughly familiar with all operating controls and their functions. Consult a Yamaha dealer regarding any control or function that you do not thoroughly understand.

EUU62800

### WARNING

1. Never start your engine or let it run for any length of time in a closed area. The exhaust fumes are poisonous and can cause loss of consciousness and death within a short time. Always operate your motorcycle in an area with adequate ventilation.

2. Before starting out, always be sure the sidestand is up. Failure to retract the sidestand completely can result in a serious accident when you try to turn a corner.

EAF13101

### Starting and warming up a cold engine

EUU02800

#### NOTE:

This motorcycle is equipped with a starting and an ignition circuit cut-off switch.

- 1 The engine can be started only under the following conditions:
  - a. The transmission is in neutral.
  - b. The sidestand is up, the transmission is in gear, and the clutch is disengaged.
2. The motorcycle must not be ridden when the sidestand is down.

**! WARNING**

Before going through the following steps, check the function of the sidestand switch and clutch switch. (Refer to page 5-15.)

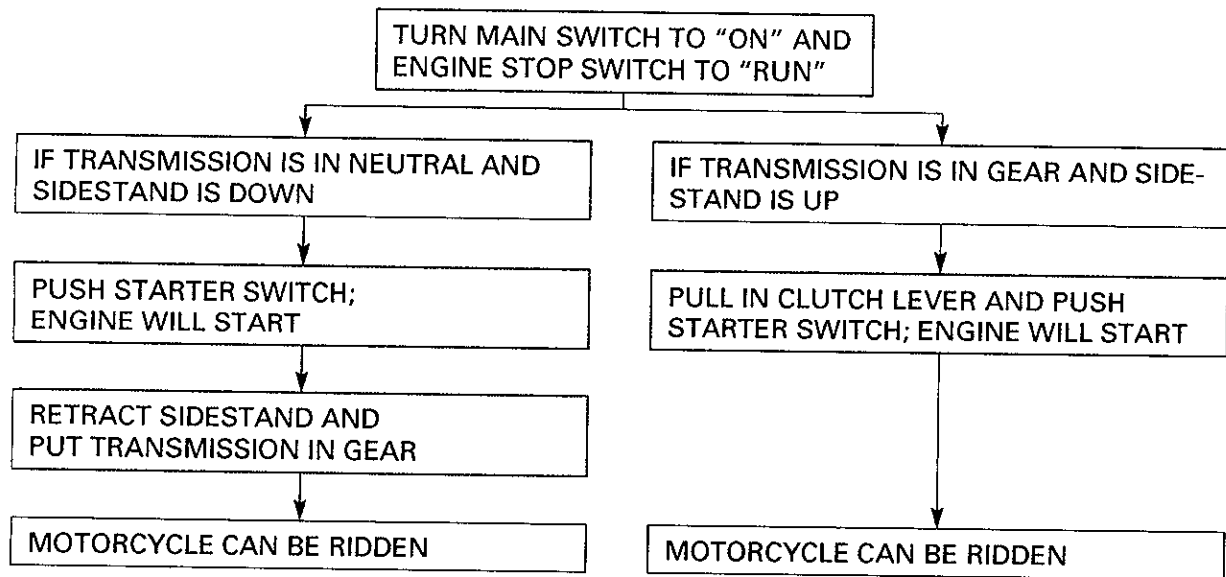



1. Turn the main switch to "ON" and the engine stop switch to "RUN."

EUU39901

**CAUTION:** \_\_\_\_\_

**If the fuel level indicator light comes on, check the fuel level. If necessary, add fuel.**

---

2. Shift transmission into neutral.

EUU03000

**NOTE:** \_\_\_\_\_

When the transmission is in neutral, the neutral indicator light (green) should be on. If the light does not come on, ask a Yamaha dealer to inspect it.

---

3. Fully open the starter (CHOKE) and completely close the throttle grip.
4. Start the engine by pushing the starter switch.

EUU02500

**NOTE:** \_\_\_\_\_

If the engine fails to start, release the starter switch, wait a few seconds, then try again. Each attempt should be as short as possible to preserve the battery. Do not crank the engine more than 10 seconds on any one attempt.

---

EUU39800

**CAUTION:** \_\_\_\_\_

**The oil level indicator light and fuel level indicator light should come on when the starter switch is pushed and should go off when the starter switch is released. If the oil level indicator light flickers or remains on, immediately stop the engine and check the engine oil level and for oil leakage. If necessary, replenish oil and check to see that the oil level indicator light goes off. If not, consult a Yamaha dealer.**

---

5. After starting the engine, turn back the starter (CHOKE) to warming up position (about halfway).

EUU02600

**NOTE:** \_\_\_\_\_

For maximum engine life, always warm up the engine before starting off. Never accelerate hard with a cold engine.

---

6. After warming up the engine, turn off the starter completely

EUU02700

**NOTE:** \_\_\_\_\_

The engine is warm when it responds normally to the throttle with the starter turned off.

---

EA10800

### **Starting a warm engine**

The starter (CHOKE) is not required when the engine is warm.

EUU31400

**CAUTION:** \_\_\_\_\_

**See "Break-in section" prior to operating the motorcycle for the first time.**

---

EA120002

### **Shifting**

The transmission lets you control the amount of power you have available at a given speed for starting, accelerating, climbing hills, etc. The use of the shift pedal is shown in the illustration. (Page 5-9)  
To shift into NEUTRAL, depress the shift pedal repeatedly until it reaches the end of its travel (you will feel a stop when you are in first gear), then raise the pedal slightly.

**CAUTION:** \_\_\_\_\_

1. **Do not coast for long periods with the engine off, and do not tow the motorcycle a long distance. Even with gears in neutral, the transmission is only properly lubricated when the engine is running. Inadequate lubrication may damage the transmission.**
  2. **Always use the clutch when changing gears. The engine, transmission, and driveline are not designed to withstand the shock of forced shifting and can be damaged by shifting without using the clutch.**
- 

**Engine break-in**

There is never a more important period in the life of your motorcycle than the period between zero and 1,000 km (600 mi). For this reason we ask that you carefully read the following material. Because the engine is brand new, you must not put an excessive load on it for the first 1,000 km (600 mi). The various parts in the engine wear and polish themselves to the correct operating clearances. During this period, prolonged full throttle operation, or any condition which might result in excessive heating of the engine, must be avoided.

1. 0 ~ 150 km (0 ~ 90 mi):  
Avoid operation above 3,000 r/min. Stop the engine and let it cool for 5 to 10 minutes after every hour of operation. Vary the speed of the motorcycle from time to time. Do not operate it at one set throttle position.

2. 150 ~ 500 km (90 ~ 300 mi):  
Avoid prolonged operation above 4,000 r/min. Rev the motorcycle freely through the gears, but do not use full throttle at any time.
3. 500 ~ 1,000 km (300 ~600 mi):  
Avoid prolonged full throttle operation. Avoid cruising speeds in excess of 5,000 r/min.

EUU31800

**CAUTION:**

After 1,000 km (600 mi) of operation, be sure to replace the engine oil, oil filter element, and final gear oil.

4. 1,000 km (600 mi) and beyond:  
Full throttle can be used.

EUU38700

**CAUTION:**

Never let engine speeds enter the red zone.

EUU32200

**CAUTION:**

If any engine trouble should occur during the break-in period, consult a Yamaha dealer immediately.

EAFA0000

**Parking**

When parking the motorcycle, stop the engine and remove the ignition key.

EUU63000

**WARNING**

The muffler and exhaust pipe are hot. Park the motorcycle in a place where pedestrians or children are not likely to touch the motorcycle. Do not park the motorcycle on a slope or soft ground; the motorcycle may overturn.

## PERIODIC MAINTENANCE AND MINOR REPAIR

EAH00400

Periodic inspection, adjustment and lubrication will keep your motorcycle in the safest and most efficient condition possible. Safety is an obligation of the motorcycle owner. The maintenance and lubrication schedule chart should be considered strictly as a guide to general maintenance and lubrication intervals. YOU MUST TAKE INTO CONSIDERATION THAT WEATHER, TERRAIN, GEOGRAPHICAL LOCATIONS, AND A VARIETY OF INDIVIDUAL USES ALL TEND TO DEMAND THAT EACH OWNER ALTER THIS TIME SCHEDULE TO SHORTER INTERVALS TO MATCH THE ENVIRONMENT. The most important points of motorcycle inspection, adjustment, and lubrication are explained in the following pages.

### WARNING

**If you are not familiar with motorcycle service, this work should be done by a Yamaha dealer.**

EAH10101

### Tool kit

The service information included in this manual is intended to provide you, the owner, with the necessary information for completing some of your own preventive maintenance and minor repairs. The tools provided in the owner's tool kit are to assist you in the performance of periodic maintenance. However, some other tools such as a torque wrench are also necessary to perform the maintenance correctly.

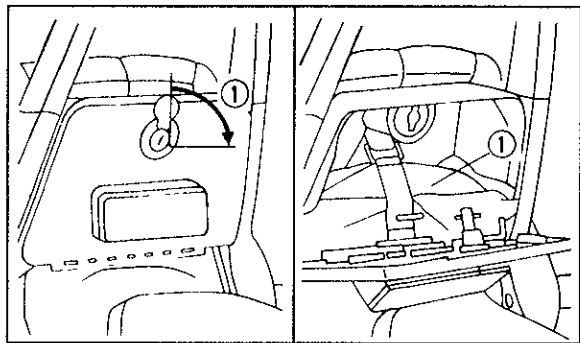

1. Open

1 Tool kit

EJU18500

**NOTE:**

If you do not have necessary tools required during a service operation, take your motorcycle to a Yamaha dealer for service.

**⚠ WARNING**

Modifications to this motorcycle not approved by Yamaha may cause loss of performance, and render it unsafe for use. Consult a Yamaha dealer before attempting any changes.

## PERIODIC MAINTENANCE / LUBRICATION

Unit km (miles)

Item	Remarks	BREAK-IN 1,000 (600)	EVERY	
			6,000 (4,000) or 6 months	12,000 (8,000) or 12 months
Valve(s)*	Check valve clearance Adjust if necessary	○	○	○
Spark plug(s)	Check condition Clean or replace if necessary	○	○	○
Air filter	Clean Replace if necessary		○	○
Carburetor*	Check idle speed/synchronization/starter operation Adjust if necessary	○	○	○
Fuel line*	Check fuel hose and vacuum pipe for cracks or damage Replace if necessary		○	○
Engine oil	Replace (Warm engine before draining)	○	○	○
Engine oil filter*	Replace.	○		○
Final gear oil	Check oil level/oil leakage Replace every 24,000 (16,000) or 24 months	Replace	○	○
Front brake*	Check operation/fluid leakage/See NOTE Correct if necessary		○	○
Rear brake	Check operation Adjust if necessary		○	○
Clutch	Check operation Adjust if necessary		○	○
Rear arm pivot*	Check rear arm assembly for looseness Correct if necessary Moderately repack every 24,000 (16,000) or 24 months **			○
Wheels*	Check balance/damage/runout Repair if necessary		○	○
Wheel bearings*	Check bearings assembly for looseness/damage Replace if damaged		○	○

Item	Remarks	BREAK-IN 1,000 (600)	EVERY	
			6,000 (4,000) or 6 months	12,000 (8,000) or 12 months
Steering bearing*	Check bearings assembly for looseness Correct if necessary Moderately repack every 24,000 (16,000) or 24 months.**	○		○
Front forks*	Check operation/oil leakage. Repair if necessary		○	○
Rear shock absorber*	Check operation/oil leakage Repair if necessary.		○	○
Fittings/Fasteners*	Check all chassis fittings and fasteners Correct if necessary	○	○	○
Center and sidestand*	Check operation Repair if necessary	○	○	○
Sidestand switch*	Check operation Clean or replace if necessary	○	○	○
Battery*	Check specific gravity. Check breather pipe for proper operation. Correct if necessary		○	○

\* It is recommended that these items be serviced by a Yamaha dealer

\*\* · Medium weight wheel bearing grease

\*\*\* · Lithium soap grease

## NOTE:

### Brake fluid replacement:

1. When disassembling the master cylinder or caliper cylinder replace the brake fluid. Normally check the brake fluid level and add the fluid as required.
2. On the inner parts of the master cylinder and caliper cylinder, replace the oil seals every two years
3. Replace the brake hoses every four years, or if cracked or damaged.



## Torque specifications

Use a torque wrench to tighten these items. It is recommended that these items be checked occasionally, especially before a long trip. Always check the tightness of these items whenever they are loosened for any reason.

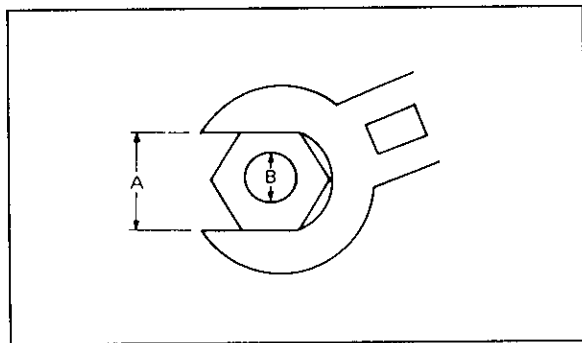

A (Nut)	B (Bolt)	General torque specifications		
		Nm	m kg	ft·lb
10 mm	6 mm	6	0.6	4.3
12 mm	8 mm	15	1.5	11
14 mm	10 mm	30	3.0	22
17 mm	12 mm	55	5.5	40
19 mm	14 mm	85	8.5	61
22 mm	16 mm	130	13.0	94

Item	Torque		
	Nm	m kg	ft lb
Spark plug	20	2.0	14
Engine drain plug	43	4.3	31
Oil filter bolt	10	1.0	7.2
Front axle pinch bolt	20	2.0	14
Front axle	105	10.5	75
Fork brace bolt	9	0.9	6.5
Rear wheel axle	105	10.5	75
Rear axle pinch bolt	20	2.0	14
Final gear drain plug	23	2.3	17

## Engine oil

1. Oil level measurement
  - a. Place the motorcycle on the center-stand. Warm up the engine for several minutes.

EUU03901

### NOTE:

Be sure the motorcycle is positioned straight up when checking the oil level. A slight tilt toward the side can result in false readings.

- b. With the engine stopped, check the oil level through the level window located at the lower part of the left side crankcase cover.

EUU04000

### NOTE:

Wait a few minutes until the oil level settles before checking.

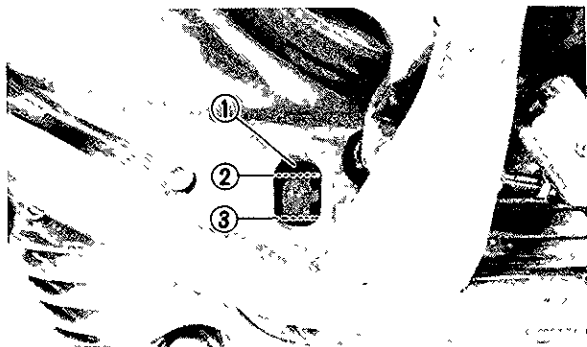

1 Level window 2 Maximum mark 3 Minimum mark

- c. The oil level should be between the maximum and minimum marks. If the level is low, add sufficient oil to raise it to the proper level.
2. Engine oil and oil filter replacement
    - a. Warm up the engine for a few minutes.
    - b. Stop the engine. Place an oil pan under the engine, and remove the oil filler cap.
    - c. Remove the drain plug and drain the oil.

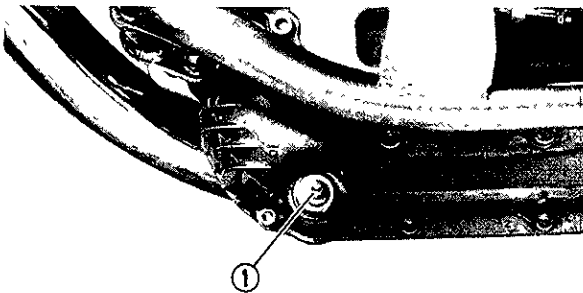

1 Drain plug

- d. Remove the oil filter bolt and filter element.

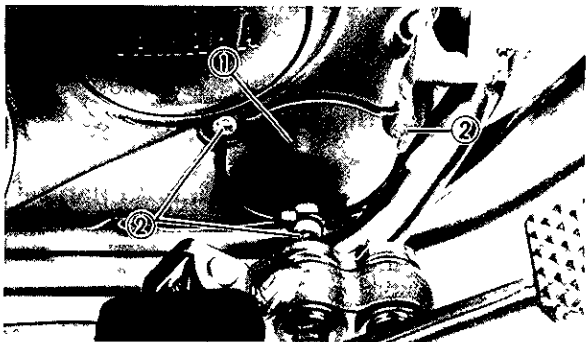

1 Oil filter cover

2 Oil filter bolt

- e. Reinstall the drain plug (make sure it is tight).

Drain plug torque:

43 Nm (4.3 m·kg, 31 ft·lb)

- f. Install the new oil filter element, new O-ring(s), and the filter cover; tighten the oil filter bolt.

Oil filter bolt torque:

10 Nm (1.0 m·kg, 7.2 ft·lb)

EUU04101

**NOTE:**

Make sure the O-ring is seated properly.

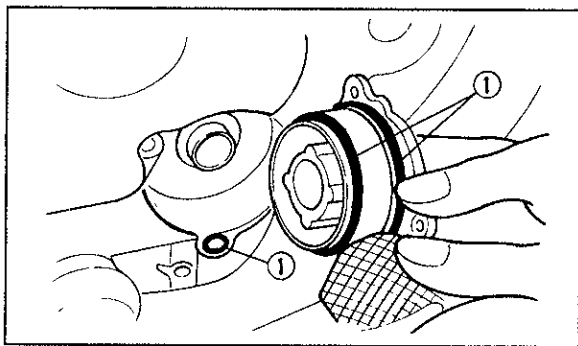

1 Proper O-ring position

- g. Fill engine with oil. Install the oil filler cap and tighten.

### Recommended oil:

30°F 40°F 50°F 60°F

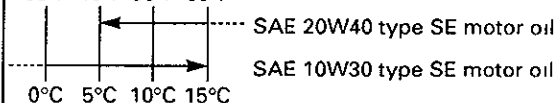

### Oil quantity:

#### Total amount:

3.6 L (3.2 Imp qt, 3.8 US qt)

#### Periodic oil change:

3.0 L (2.6 Imp qt, 3.2 US qt)

#### With oil filter replacement:

3.1 L (2.7 Imp qt, 3.3 US qt)

EUU08000

### NOTE:

Recommended engine oil classification; API Service "SE", "SF" type or equivalent (e.g. "SF-SE", "SF-SE-CC", "SF-SE-SD" etc.).

**CAUTION:** \_\_\_\_\_

Do not put in any chemical additives. Engine oil also lubricates the clutch and additives could cause clutch slippage.

---

**CAUTION:** \_\_\_\_\_

Be sure no foreign material enters the crankcase.

---

- h. Start the engine and warm up for a few minutes. While warming up, check for oil leakage. If oil leakage is found, stop the engine immediately, and check for the cause.
- i. After the engine is started, the oil level indicator light should go off if oil is filled to proper level.

**CAUTION:** \_\_\_\_\_

If the indicator light flickers or remains on, immediately stop the engine and consult a Yamaha dealer.

---

**Final gear oil**** WARNING** \_\_\_\_\_

Do not let foreign material enter the final gear case. Be sure oil does not get on the tire or wheel.

---

- 1 Oil level measurement
  - a. Place the motorcycle on a level place, and place it on the centerstand. The engine should be cool (at ambient temperature).
  - b. Remove the oil filler cap and check the oil level. The oil level should be at the brim of the hole. Add oil as necessary.

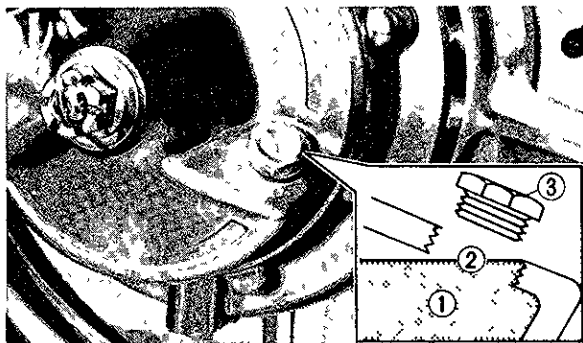

1 Final gear oil 2 Correct oil level 3 Oil filler cap

2. Gear oil replacement

- a. Place an oil pan under the final gear case.
- b. Remove the final gear oil filler cap and the drain plug; drain the oil.

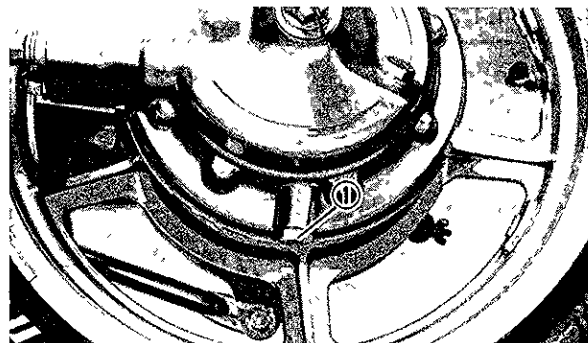

1 Final gear drain plug

- c. Reinstall and tighten the final gear case drain plug.

Drain plug torque:  
23 Nm (2.3 m·kg, 17 ft·lb)

d. Fill the gear case to the specified level.

Oil capacity:

Final gear case:

0.2 L (0.18 Imp qt, 0.21 US qt)

Recommended oil:

SAE 80 API GL-4 Hypoid gear oil

If desired, an SAE 80W90 hypoid gear oil may be used for all conditions.

EUU02300

**NOTE:**

“GL-4” is a quality and additive rating. “GL-5” or “GL-6” rated hypoid gear oils may also be used.

e. Reinstall the filler cap.

f. After replacement of final gear oil, be sure to check for oil leaks.

EAH60801

**Air filter**

The air filter element should be cleaned at the specified intervals. It should be cleaned more frequently if you are riding in unusually wet or dusty areas.

1. Remove the seat.

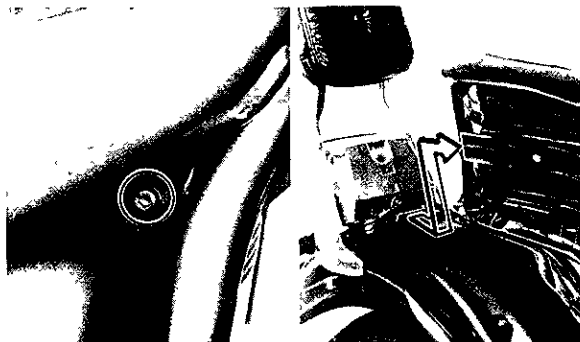

2. Remove the fuel tank.

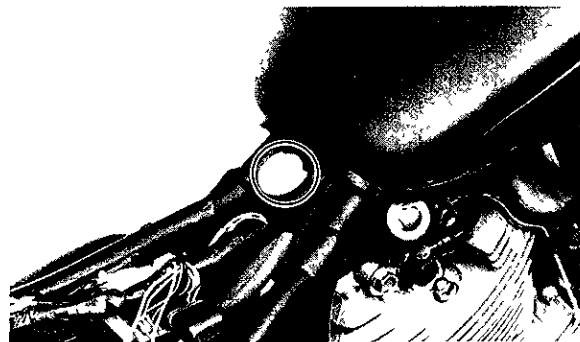

3. Remove the air filter case assembly.

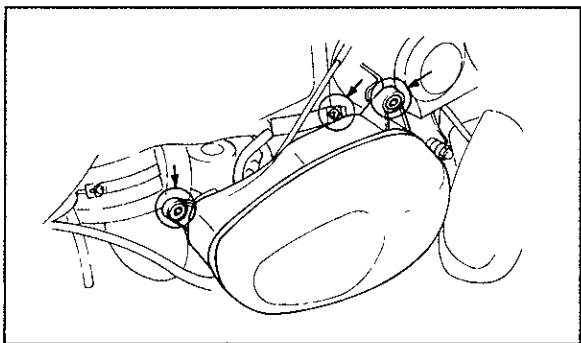

4. Remove the air filter case cover.

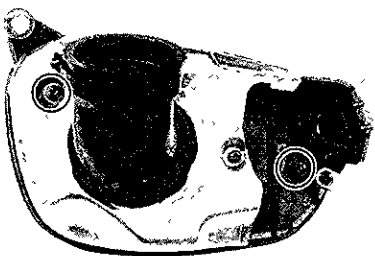

5. Remove the element.

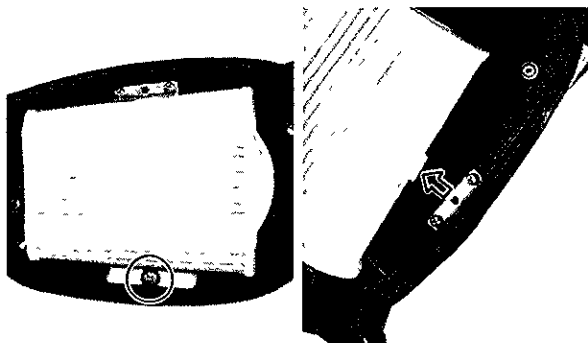

6. Tap the element lightly to remove most of the dust and dirt and blow out the remaining dirt with compressed air from the inner surface of the element. If the element is damaged, replace it.





7. Reassemble by reversing the removal procedure.

EUU35701

**CAUTION:** \_\_\_\_\_

**Make sure the element is properly seated in the filter case.**

---

EUU42400

**CAUTION:** \_\_\_\_\_

**The engine should never be run without the air filter element installed; excessive piston and/or cylinder wear may result.**

---

EAH90001

### **Carburetor adjustment**

The carburetor is a vital part of the engine and requires very sophisticated adjustment. Most adjustments should be left to a Yamaha dealer who has the professional knowledge and experience to do so. However, the following may be serviced by the owner as part of routine maintenance.

EUU33001

**CAUTION:** \_\_\_\_\_

**The carburetor was set at the Yamaha factory after many tests. If the settings are changed, poor engine performance and damage may result.**

---

EAH90100

### **Idle speed adjustment**

1. Start the engine and warm it up for a few minutes (normally, 1 or 2 minutes) at approximately 1,000 to 2,000 r/min. Occasionally rev the engine to 4,000 to 5,000 r/min. The engine is warm when it quickly responds to the throttle.

2. Set the idle to the specified engine speed by adjusting the throttle stop screw; turn the screw in to increase engine speed, and out to decrease engine speed.

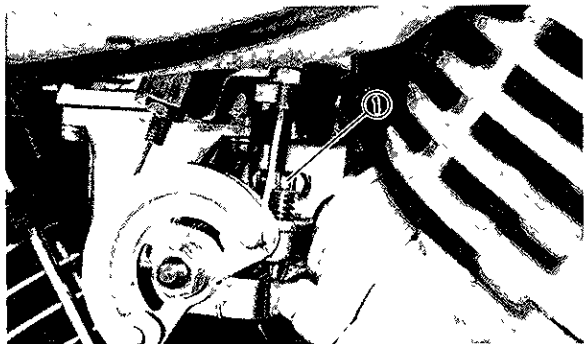

1 Throttle stop screw

Standard idle speed:  
950 ~ 1,050 r/min

EUU04500

**NOTE:**

If the specified idle speed cannot be obtained by performing the above adjustment, consult a Yamaha dealer.

EAH90301

## Throttle cable adjustment

EUU06400

**NOTE:**

Before adjusting the throttle cable free play, the engine idling speed should be adjusted.

Adjust the throttle cable by turning the adjuster so that proper free play at the throttle grip is obtained.

Free play:

3 ~ 5 mm (0.12 ~ 0.20 in)

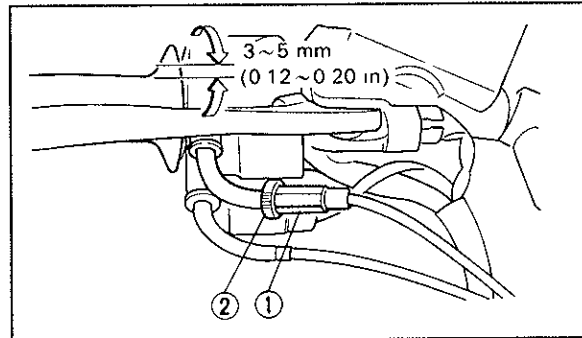

1 Adjuster

2 Lock nut

1. Loosen the lock nut.
2. Turn the adjuster in or out until specified free play is obtained.
3. Tighten the lock nut.

EAH90800

### **Valve clearance adjustment**

The valve clearance becomes larger with use, resulting in improper fuel/air supply and engine noise. To prevent this, the valve clearance must be adjusted regularly. This adjustment, however, should be left to a professional Yamaha service technician.

EAH20101

### **Spark plug inspection**

The spark plug is an important engine component and is easy to inspect. The condition of the spark plug can indicate the condition of the engine.

Normally, all spark plugs from the same engine should have the same color on the white porcelain insulator around the center electrode. The ideal color at this point is a medium to light tan color for a motorcycle that is being ridden normally. If one spark plug shows a distinctly different color, there could be something wrong with the engine.

Do not attempt to diagnose such problems yourself. Instead, take the motorcycle to a Yamaha dealer. You should periodically remove and inspect the spark plugs because heat and deposits will cause any spark plug to slowly break down and erode. If electrode erosion becomes excessive, or if carbon and other deposits are excessive, you should replace the spark plug with the specified plug.

Standard spark plug:  
BPR7ES (NGK) or  
W22EPR-U (NIPPONDENSO)

Before installing any spark plug, measure the electrode gap with a wire thickness gauge; adjust the gap to specification

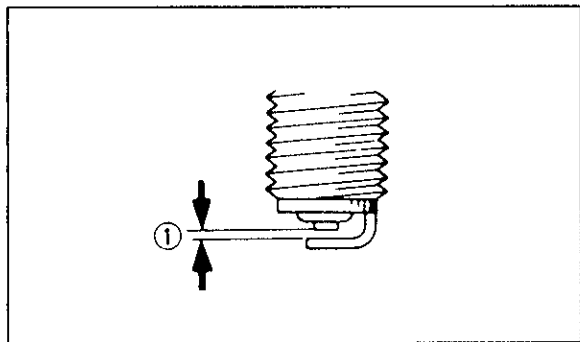

1 Spark plug gap

Spark plug gap:  
0.7 ~ 0.8 mm (0.028 ~ 0.031 in)

When installing the plug, always clean the gasket surface and use a new gasket. Wipe off any grime from the threads, and torque the spark plug properly.

Spark plug torque:  
20 Nm (2.0 m·kg, 14.0 ft·lb)

EUU03801

**NOTE:**

If a torque wrench is not available when you are installing a spark plug, a good estimate of the correct torque is 1/4 to 1/2 turn past finger tight. Have the spark plug torqued to the correct value as soon as possible with a torque wrench.

### Front brake adjustment

The free play at the end of the front brake lever should be 2 ~ 5 mm (0.08 ~ 0.2 in).

- 1 Loosen the lock nut.
- 2 Turn the adjuster so that the brake lever movement at the lever end is 2 ~ 5 mm (0.08 ~ 0.2 in) before the adjuster contacts the master cylinder piston.
3. After adjusting, tighten the lock nut.

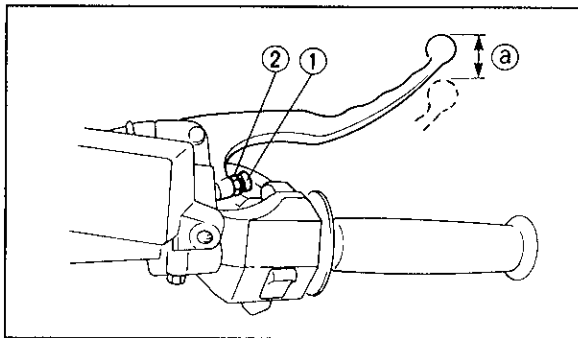

1 Adjuster    2 Lock nut    a 2~5 mm (0.08~0.2 in)

### **⚠ WARNING**

**Check the brake lever free play. Be sure the brake is working properly.**

### **⚠ WARNING**

**A soft or spongy feeling in the brake lever can indicate the presence of air in the brake system. This air must be removed by bleeding the brake system before the motorcycle is operated. Air in the system will cause greatly diminished braking capability and can result in loss of control and an accident. Have a Yamaha dealer inspect and bleed the system if necessary.**

## Rear brake adjustment

EUU64300

### **⚠ WARNING**

For brake pedal adjustment, be sure to proceed as follows (it is advisable to have a Yamaha dealer make this adjustment).

1. Pedal height
  - a. Loosen the lock nut.
  - b. By turning the adjuster clockwise or counterclockwise, adjust the brake pedal position as shown.
  - c. Tighten the lock nut.

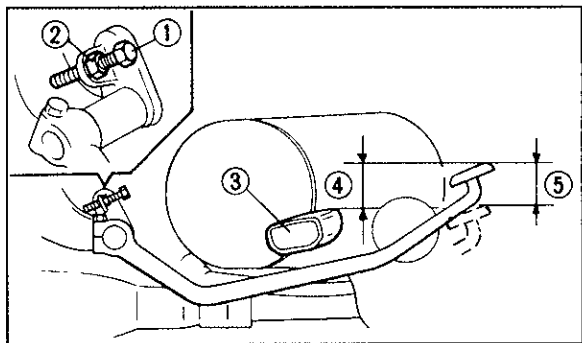

1. Adjuster bolt (for pedal height)
2. Lock nut
3. Footrest
4. Pedal height: 40 mm (1.6 in)
5. Free play: 20~30 mm (0.8~1.2 in)

EUU64400

### **⚠ WARNING**

After adjusting the pedal height adjust brake pedal free play.

## 2. Free play

The rear brake pedal free play should be adjusted to 20 ~ 30 mm (0.8 ~ 1.2 in) at the brake pedal end. Turn the adjuster on the brake rod clockwise to reduce play or counterclockwise to increase play.

EUU64500

### **⚠ WARNING**

**Check the operation of the brake light after adjusting the rear brake.**

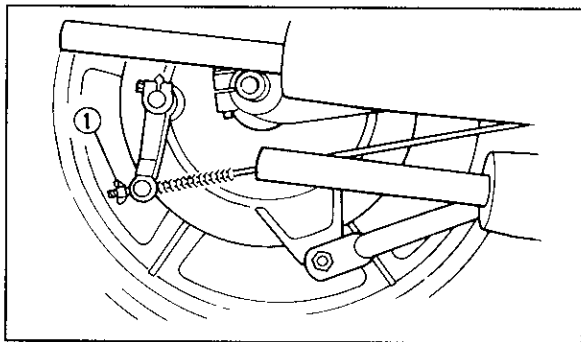

1 Adjuster

EAH83301

## Brake light switch adjustment

The brake light switch is operated by movement of the brake pedal. To adjust, hold the main body of the switch so it does not rotate and turn the adjusting nut. Proper adjustment is achieved when the brake light comes on just before the brake begins to take effect.

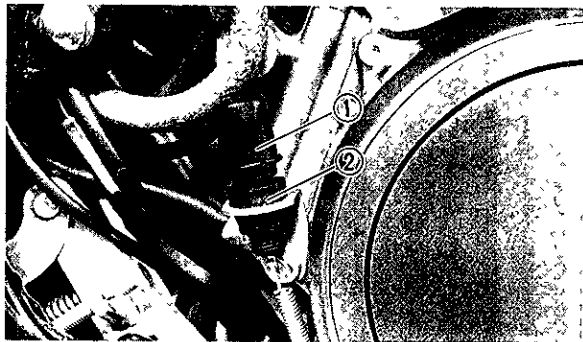

1 Main body

2 Adjusting nut

EAH81401

## Checking the front brake pads and rear brake shoes

A wear indicator is provided on each brake. This indicator allows checking of brake pad/shoe wear without disassembling the brake.

EAH82101

### FRONT

Apply the brake and inspect the wear indicator.

If the wear indicator is **ALMOST** in contact with the disc plate, ask a Yamaha dealer to replace the pads.

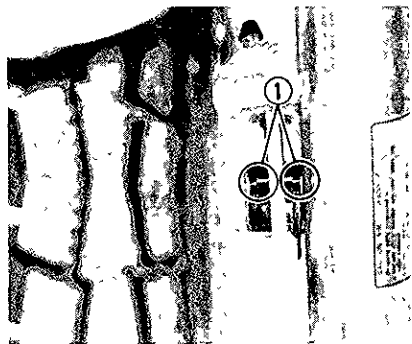

1 Wear indicator

EAH82601

### REAR

Apply the brake and inspect the wear indicator.

If the indicator reaches the wear limit line, ask a Yamaha dealer to replace the shoes.

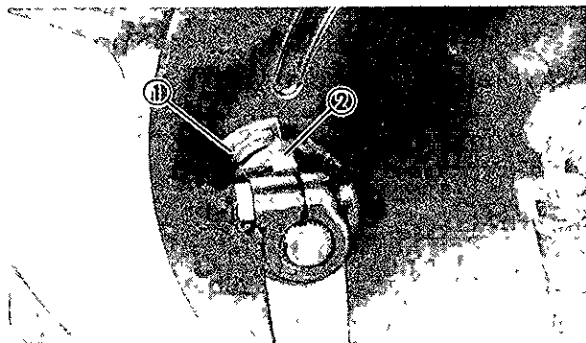

1 Wear limit

2 Wear indicator

EAH88201

## Inspecting the brake fluid level

Insufficient brake fluid may let air enter the brake system, possibly causing the brakes to become ineffective.

Before riding, check the brake fluid level and replenish when necessary.



## Mechanism adjustment

The second adjustment is located behind the adjusting cover. Removing the cover will expose the adjuster and lock nut. (Before making the mechanism adjustment, loosen the clutch cable length adjuster.)

Loosen the lock nut, rotate the adjuster in until it lightly seats against the clutch push rod. Back the adjuster out 1/4 turn and tighten the lock nut. This adjustment must be checked because heat and clutch wear can cause incomplete clutch operation. Check the clutch cable adjustment at the handlebar after adjusting.

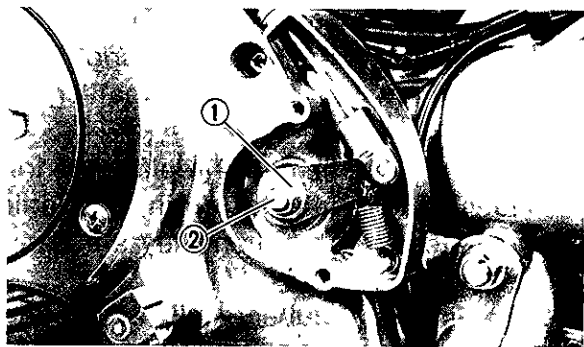

1 Lock nut

2 Adjuster

EAI10701

## Cable inspection and lubrication

EUU64601

### **⚠ WARNING**

Damage to the outer housing of cables may allow internal rusting and cause interference with cable movement. Replace damaged cables as soon as possible to prevent unsafe conditions.

Lubricate the inner cable and the cable end. If it does not operate smoothly, ask a Yamaha dealer to replace them.

Recommended lubricant:  
SAE 10W30 motor oil

EAI10201

### Throttle cable and grip lubrication

The throttle twist grip assembly should be greased at the time that the cable is lubricated, since the grip must be removed to get at the end of the throttle cable. After removing the screws, hold the end of the cable up in the air and put in several drops of lubricant. With the throttle grip disassembled, coat the metal surface of the grip assembly with a suitable all-purpose grease.

EAI30601

### Brake and shift pedals

Lubricate the pivoting parts

Recommended lubricant:  
SAE 10W30 motor oil

EAI30700

### Brake and clutch levers

Lubricate the pivoting parts.

Recommended lubricant:  
SAE 10W30 motor oil

EAI30801

### Center and sidestand

Lubricate the pivoting parts. Check to see that the center and sidestand move up and down smoothly.

Recommended lubricant:  
SAE 10W30 motor oil

EUU69301



**If the center and/or sidestand does not move smoothly, consult a Yamaha dealer.**

**NOTE:**

An optional air check gauge is available  
Please ask a nearby Yamaha dealer.

Standard air pressure.

40 kPa (0.4 kgf/cm<sup>2</sup>, 5.7 psi)

Maximum air pressure:

120 kPa (1.2 kgf/cm<sup>2</sup>, 17.1 psi)

Minimum air pressure:

40 kPa (0.4 kgf/cm<sup>2</sup>, 5.7 psi)

**CAUTION:**

Never exceed the maximum pressure, or  
oil seal damage may occur.

4. Install the valve cap securely.

**Rear shock absorber adjustment**

This shock absorber is equipped with a  
spring preload and damping force adjust-  
er.

1. Adjust spring preload as follows.  
Turn adjuster in direction ① to in-  
crease spring preload and in direction  
② to decrease spring preload.

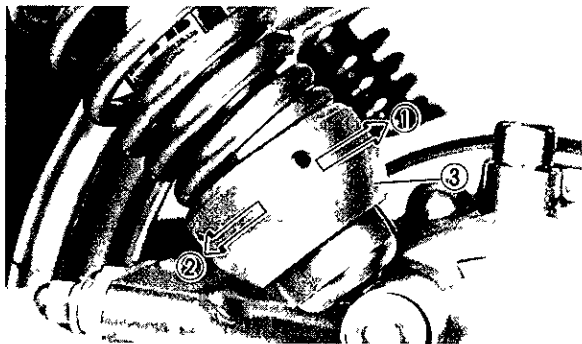

- 1 Increase
- 2 Decrease
- 3 Spring preload adjuster

Standard position: 1

1. – Softest
5. – Stiffest

2. Adjust damping force as follows.  
Turn adjuster in direction ② to increase damping force and in direction ③ to decrease damping force.

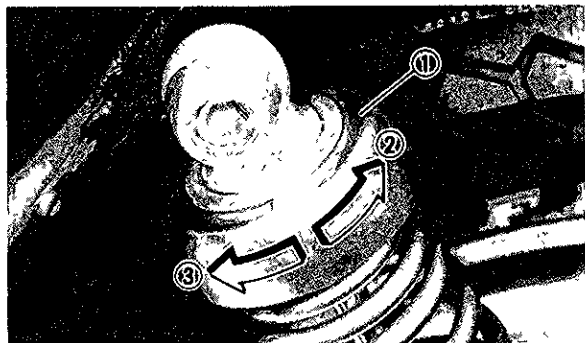

1 Damping adjuster    2 Increase    3 Decrease

Standard position: 1

1 – Minimum

4 – Maximum

**! WARNING**

**Always adjust each shock absorber to the same setting. Uneven adjustment can cause poor handling and loss of stability.**

**CAUTION:**

When inspecting the battery, be sure the breather pipe is routed correctly. If the breather pipe is positioned in such a way as to cause battery electrolyte or gas to exit onto the frame, structural and cosmetic damage to the motorcycle can occur.

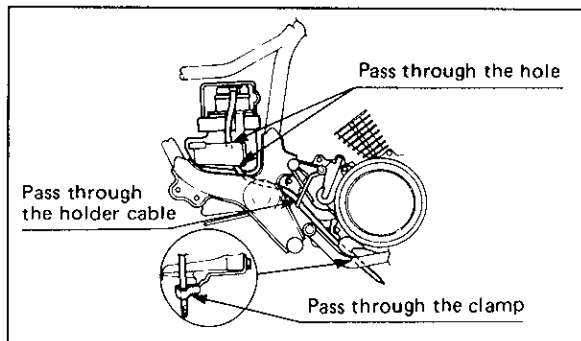
**WARNING**

Battery electrolyte is poisonous and dangerous, causing severe burns, etc. It contains sulfuric acid. Avoid contact with skin, eyes or clothing.

Antidote: EXTERNAL-Flush with water. INTERNAL-Drink large quantities of water or milk. Follow with milk of magnesia, beaten egg, or vegetable oil. Call a physician immediately.

Eyes: Flush with water for 15 minutes and get prompt medical attention. Batteries produce explosive gases. Keep sparks, flame, cigarettes etc., away. Ventilate when charging or using in an enclosed space. Always shield your eyes when working near batteries.

**KEEP OUT OF REACH OF CHILDREN.**

## Replenishing the battery fluid

A poorly maintained battery will corrode and discharge quickly. The battery fluid should be checked at least once a month.

1. The level should be between the upper and lower level marks. Use only distilled water if refilling is necessary.

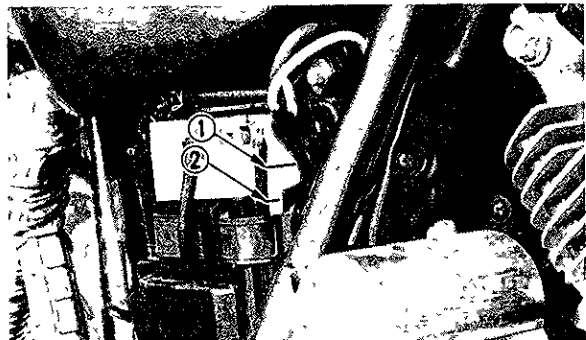

1 Upper level

2 Lower level

## CAUTION:

**Normal tap water contains minerals which are harmful to a battery; therefore, refill only with distilled water.**

2. When the motorcycle will not be used for a month or longer, remove the battery and store it in a cool, dark place. Completely recharge the battery before reusing.
3. If the battery will be stored for a longer period than the above, check the specific gravity of the fluid at least once a month and recharge the battery when it is too low.
4. Always make sure the connections are correct when putting the battery back in the motorcycle. Make sure the breather pipe is properly connected and is not damaged or obstructed.

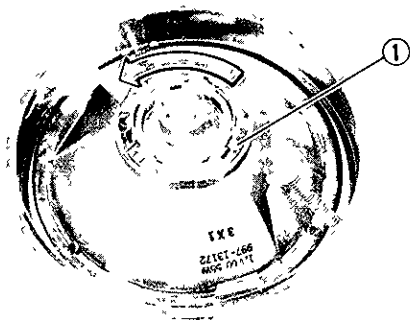

1 Bulb holder

EUU66001

**⚠ WARNING**

**Keep flammable products and your hands away from the bulb while it is on, as it is hot. Do not touch the bulb until it cools down.**

- Put a new bulb into position and secure it in place with the bulb holder

**CAUTION:**

**Avoid touching the glass part of the bulb. Keep it free from oil; otherwise, the transparency of the glass, life of the bulb, and illuminous flux will be adversely affected. If oil gets on the bulb, thoroughly clean it with a cloth moistened with alcohol or lacquer thinner.**

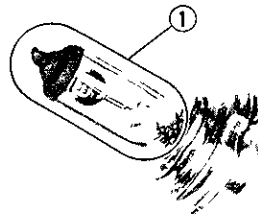

1 Don't touch

5. Install the cover.
6. Connect headlight lead(s).
7. Install the light unit assembly.  
If the headlight beam adjustment is necessary, ask a Yamaha dealer to make adjustment.

EAJ21902

### Front wheel removal

EUU66201

#### **⚠ WARNING**

It is advisable to have a Yamaha dealer service the wheel.

EUU65700

#### **⚠ WARNING**

Securely support the motorcycle so there is no danger of it falling over.

1. Place the motorcycle on the center-stand.
2. Remove the speedometer cable from the front wheel side.

3. Remove the front fork brace with fender.

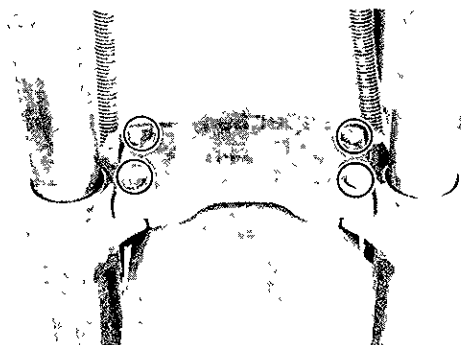

4. Loosen the pinch bolt.

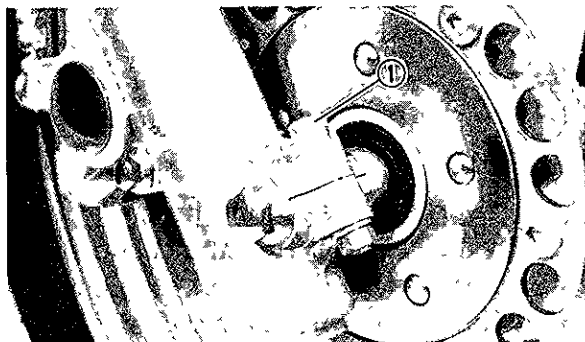

1 Pinch bolt



1. Place the motorcycle on the center-stand.
2. Remove the tension bar and the brake rod from the rear wheel side. The tension bar can be removed by removing the cotter pin and nut from the tension bar bolt. The brake rod can be removed by removing the adjuster.

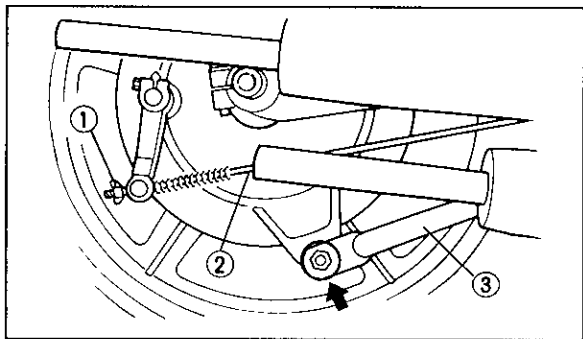

1 Adjuster      2 Brake rod      3 Tension bar

3. Remove the axle nut cotter pin and the axle nut.
4. Loosen the rear axle pinch bolt and pull out the rear axle.

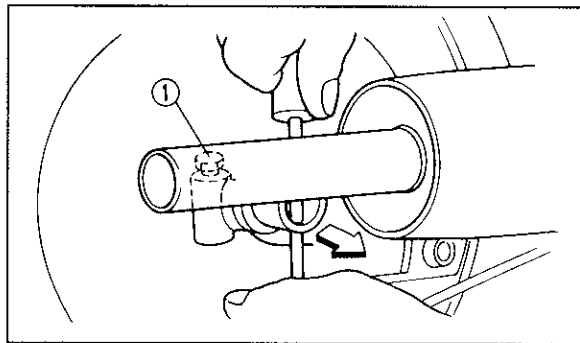

1 Pinch bolt

5. Move the wheel to the right to separate it from the final gear case and remove the rear wheel.

## Rear wheel installation

When installing the rear wheel, reverse the removal procedure. Pay attention to the following points:

1. Apply a light coating of lithium base grease to final gear case splines and rear wheel hub splines.
2. Make sure the splines on the wheel hub fit into the final gear case.

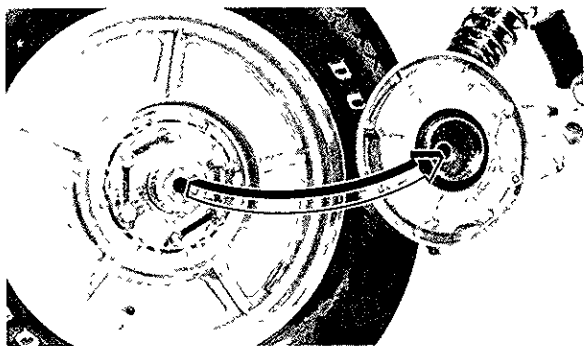

3. Make sure the axle nut and tension bar bolt are properly torqued, and a new cotter pin is installed.

EUU78000

### **⚠ WARNING**

**Always use a new cotter pin.**

Tightening torque:

Axle nut:

105 Nm (10.5 m·kg, 75 ft·lb)

Axle pinch bolt:

20 Nm (2.0 m·kg, 14 ft·lb)

Tension bar bolt:

20 Nm (2.0 m·kg, 14 ft·lb)

4. Adjust the rear brake. (See page 8-18)

EUU64500

### **⚠ WARNING**

**Check the operation of the brake light after adjusting the rear brake.**

## CLEANING AND STORAGE

EAK01101

### A. CLEANING

Frequent, thorough cleaning of your motorcycle will not only enhance its appearance but will improve its general performance and extend the useful life of many components.

1. Before cleaning the motorcycle:
  - a. Block off the end of the exhaust pipe to prevent water entry; a plastic bag and strong rubber band may be used.
  - b. Make sure the spark plug(s) and all filler caps are properly installed.
2. If the engine case is excessively greasy, apply degreaser with a paint brush. Do not apply degreaser to wheel axles.
3. Rinse the dirt and degreaser off with a garden hose. Use only enough pressure to do the job.

### CAUTION:

---

**Excessive hose pressure may cause water seepage and deterioration of wheel bearings, front fork, brakes and transmission seals. Many expensive repair bills have resulted from improper high pressure detergent applications such as those available in coin-operated car washers.**

---

4. Once the majority of the dirt has been hosed off, wash all surfaces with warm water and mild, detergent-type soap. An old toothbrush or bottle brush is handy for hard-to-get-at places.
5. Rinse the motorcycle off immediately with clean water and dry all surfaces with a chamois, clean towel, or soft absorbent cloth.
6. Clean the seat with a vinyl upholstery cleaner to keep the cover pliable and glossy.

7. Automotive-type wax may be applied to all painted and chrome-plated surfaces. Avoid combination cleaner-waxes. Many contain abrasives which may mar the paint or protective finish. When finished, start the engine and let it idle for several minutes.

EAK00400

## **B. STORAGE**

Long term storage (60 days or more) of your motorcycle will require some preventive procedures to guard against deterioration. After thoroughly cleaning the motorcycle, prepare for storage as follows:

1. Drain the fuel tank, fuel lines, and carburetor float bowl(s).
2. Remove the empty fuel tank, pour a cup of SAE 10W30 or 20W40 motor oil in the tank, shake the tank to coat the inner surfaces thoroughly and drain off the excess oil. Reinstall the tank.
3. Remove the spark plug, pour about one tablespoon of SAE 10W30 or 20W40 motor oil in the spark plug hole and reinstall the spark plug. Turn the engine over several times (ground spark plug lead wires) to coat the cylinder walls with oil.

**⚠ WARNING**

**When using the starter motor to crank the engine, remove the spark plug wires, and ground them to prevent sparking.**

---

4. Lubricate all control cables.
5. Block up the frame to raise both wheels off the ground
6. Tie a plastic bag over the exhaust pipe outlet to prevent moisture from entering.
7. If storing in a humid or salt-air atmosphere, coat all exposed metal surfaces with a light film of oil. Do not apply oil to any rubber parts or the seat cover.
8. Remove the battery and charge it. Store it in a dry place and recharge it once a month. Do not store the battery in an excessively warm or cold place (less than 0°C (30°F) or more than 30°C (90°F)).

**NOTE:**

Make any necessary repairs before storing the motorcycle.

---

# SPECIFICATIONS

Model	XV1100E
Dimension: Overall length Overall width Overall height Seat height Wheel base Minimum ground clearance	2,285 mm (90 0 in) 840 mm (33 1 in) 1,190 mm (46.9 in) 715 mm (28.1 in) 1,525 mm (60 0 in) 145 mm ( 5 7 in)
Basic weight: With oil and full fuel tank	239 kg (527 lb)
Minimum turning radius:	2,800 mm (110 in)
Engine: Type Model Cylinder arrangement Displacement Bore × Stroke Compression ratio Starting system Lubrication system	Air cooled, 4-stroke, gasoline, SOHC 3EG6 V-2 cylinder 1,063 cm <sup>3</sup> (64.9 cu. in) 95 0 × 75.0 mm (3.74 × 2.95 in) 8.3 : 1 Electric starter Wet sump

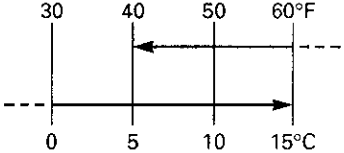
Model	XV1100E
<p>Engine oil (4-cycle) Type</p>  <p>Capacity Periodic oil change With oil filter replacement Total amount</p>	<p>SAE 20W40 type SE motor oil (If temperature does not go below 5°C/40°F) SAE 10W30 type SE motor oil (If temperature does not go above 15°C/60°F)</p> <p>3.0 L (2.6 Imp qt, 3.2 US qt) 3.1 L (2.7 Imp qt, 3.3 US qt) 3.6 L (3.2 Imp qt, 3.8 US qt)</p>
<p>Final gear oil Type Capacity</p>	<p>SAE 80 API GL-4 Hypoid gear oil 0.2 L (0.18 Imp qt, 0.21 US qt)</p>
<p>Air filter</p>	<p>Dry type element</p>
<p>Fuel. Type Tank capacity Reserve amount</p>	<p>Regular gasoline For Australia Unleaded fuel only 16.8 L (3.7 Imp gal, 4.4 US gal) 3.0 L (0.7 Imp gal, 0.8 US gal)</p>
<p>Carburetor: Type/manufacturer</p>	<p>BST40/MIKUNI</p>
<p>Spark plug Type/manufacturer Gap</p>	<p>BPR7ES (NGK) or W22EPR-U (NIPPONDENSO) 0.7 ~ 0.8 mm (0.028 ~ 0.031 in)</p>

Model	XV1100E
Clutch type.	Wet, multi-disc
Transmission: Primary reduction system Primary reduction ratio Secondary reduction system Secondary reduction ratio Transmission type Operation Gear ratio            1st 2nd 3rd 4th 5th	Spur gear 78/47 (1.659) Shaft drive 45/46 × 19/18 × 32/11 (3.003) Constant mesh 5-speed Left foot operation 39/17 (2.294) 40/24 (1.666) 36/28 (1.285) 32/31 (1.032) 29/34 (0.852)
Chassis: Frame type Caster angle Trail	Pressed backbone 32° 129 mm (5.1 in)
Tire: Type Size – Front Rear	Tubeless 100/90-19 57H 140/90-15 M/C 70H
Brake: Front brake type Operation Rear brake type Operation	Dual, Disc brake Right hand operation Drum brake Right foot operation



Model		XV1100E
Suspension	Front Rear	Telescopic fork Swingarm
Shock absorber	Front Rear	Air/Coil spring, Oil damper Coil spring, Oil damper
Wheel travel	Front Rear	150 mm (5.9 in) 97 mm (3.8 in)
Electrical:		
Ignition system		TCI
Generator system		AC magneto
Battery type/capacity		GM18Z-3A/12V 20AH
Headlight type		Quartz bulb
Bulb wattage/quantity		
Headlight		12V 60W/55W
Tail/brake light		12V 5W/21W × 2
Flasher light		12V 21W × 4
Meter light		12V 3W × 4
Indicator light wattage/quantity:		
"NEUTRAL"		12V 3W
"HIGH BEAM"		12V 3W
"OIL LEVEL"		12V 3W
"TURN"		12V 3W × 2
"FUEL"		12V 3W

## **NOISE REGULATION (FOR Australia)**

### **"TAMPERING WITH NOISE CONTROL SYSTEM PROHIBITED"**

Owners are warned that the law may prohibit:

- (a) The removal or rendering inoperative by any person other than for purposes of maintenance, repair or replacement, of any device or element of design incorporated into any new vehicle for the purpose of noise control prior to its sale or delivery to the ultimate purchaser or while it is in use; and
- (b) the use of the vehicle after such device or element of design has been removed or rendered inoperative by any person.

**YAMAHA MOTOR CO.,LTD.**

PRINTED IN JAPAN  
92 · 9 - 03 × 1 CR  
(英)



# WIRING DIAGRAM

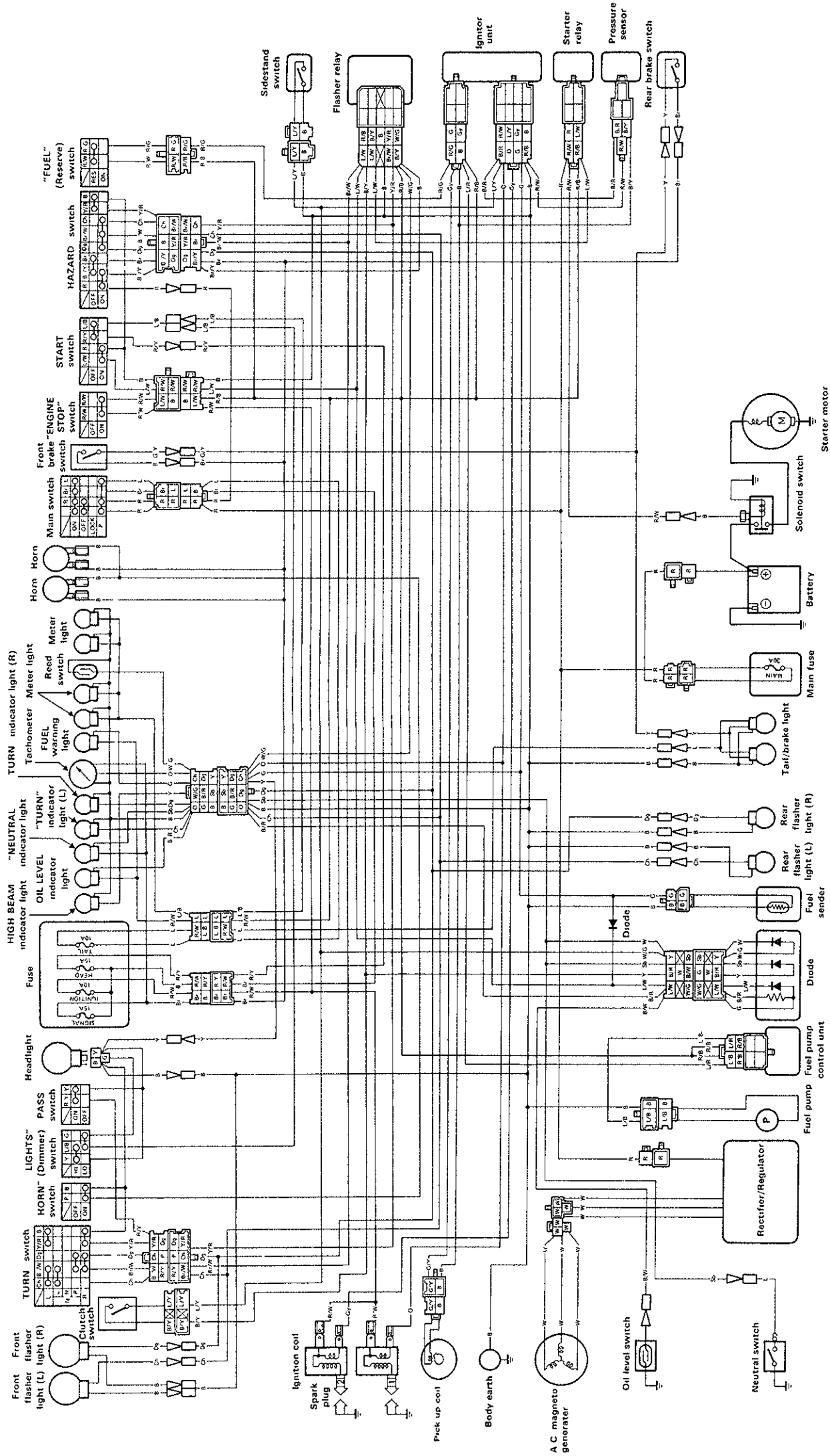

## COLOR CODE

B	Black	P	Pink	Sb	Sky blue	B/W	Black/White	G/Y	Green/Yellow	R/W	Red/White
L	Blue	O	Orange	Dg	Dark green	L/B	Blue/Black	Y/R	Yellow/Red	Br/W	Brown/White
G	Green	Br	Brown	W	White	L/Y	Blue/Yellow	R/B	Red/Black	W/G	White/Green
Y	Yellow	Ch	Chocolate	B/Y	Black/Yellow	L/R	Blue/Red	R/Y	Red/Yellow		
R	Red	Gy	Gray	B/R	Black/Red	L/W	Blue/White	R/G	Red/Green		