



**OWNER'S MANUAL**



***XVS650M***



***XVS650AM***

**4XS-28199-23**

Congratulations on your purchase of the Yamaha XVS650/XVS650A. This model is the result of Yamaha's vast experience in the production of fine sporting, touring, and pacesetting racing machines. It represents the high degree of craftsmanship and reliability that have made Yamaha a leader in these fields.

This manual will give you an understanding of the operation, inspection, and basic maintenance of this motorcycle. If you have any questions about the operation or maintenance of your motorcycle, please consult a Yamaha dealer.

# IMPORTANT MANUAL INFORMATION

---

---

Particularly important information is distinguished in this manual by the following notations:



The Safety Alert Symbol means ATTENTION! BECOME ALERT! YOUR SAFETY IS INVOLVED!



Failure to follow WARNING instructions could result in severe injury or death to the motorcycle operator, a bystander or a person inspecting or repairing the motorcycle.

**CAUTION:**

A CAUTION indicates special precautions that must be taken to avoid damage to the motorcycle.

**NOTE:**

A NOTE provides key information to make procedures easier or clearer.

**NOTE:**

- This manual should be considered a permanent part of this motorcycle and should remain with it even if the motorcycle is subsequently sold.
  - Yamaha continually seeks advancements in product design and quality. Therefore, while this manual contains the most current product information available at the time of printing, there may be minor discrepancies between your motorcycle and this manual. If there is any question concerning this manual, please consult your Yamaha dealer.
-

# IMPORTANT MANUAL INFORMATION

---

---

EW000002



---

**PLEASE READ THIS MANUAL CAREFULLY AND COMPLETELY BEFORE OPERATING THIS MOTORCYCLE.**

---



# **IMPORTANT MANUAL INFORMATION**

---

---

EAU00008

**XVS650M/XVS650AM**

**OWNER'S MANUAL**

**© 1999 by Yamaha Motor Co., Ltd.**

**1st Edition, November 1999**

**All rights reserved. Any reprinting or  
unauthorized use without the written  
permission of Yamaha Motor Co., Ltd.  
is expressly prohibited.**

**Printed in Japan.**

1 SAFETY INFORMATION	1
2 DESCRIPTION	2
3 INSTRUMENT AND CONTROL FUNCTIONS	3
4 PRE-OPERATION CHECKS	4
5 OPERATION AND IMPORTANT RIDING POINTS	5
6 PERIODIC MAINTENANCE AND MINOR REPAIR	6
7 MOTORCYCLE CARE AND STORAGE	7
8 SPECIFICATIONS	8
9 CONSUMER INFORMATION	9
INDEX	



Safe riding ..... 1-1  
Protective apparel ..... 1-3  
Modification ..... 1-3  
Loading and accessories ..... 1-3  
Gasoline and exhaust gas..... 1-5  
Location of the important labels ..... 1-7



TWO-WHEELED MOTORCYCLES ARE SINGLE TRACK VEHICLES. THEIR SAFE USE AND OPERATION ARE DEPENDENT UPON THE USE OF PROPER RIDING TECHNIQUES AS WELL AS THE EXPERTISE OF THE OPERATOR. EVERY OPERATOR SHOULD KNOW THE FOLLOWING REQUIREMENTS BEFORE RIDING.

HE OR SHE SHOULD:

1. OBTAIN THOROUGH INSTRUCTIONS FROM A COMPETENT SOURCE ON ALL ASPECTS OF MOTORCYCLE OPERATION.
2. OBSERVE THE WARNINGS AND MAINTENANCE REQUIREMENTS IN THE OWNER'S MANUAL.
3. OBTAIN QUALIFIED TRAINING IN SAFE AND PROPER RIDING TECHNIQUES.
4. OBTAIN PROFESSIONAL TECHNICAL SERVICE AS INDICATED BY THE OWNER'S MANUAL AND/OR WHEN MADE NECESSARY BY MECHANICAL CONDITIONS.

## Safe riding

1. Always make pre-operation checks. Careful checks may help prevent an accident.
2. This motorcycle is designed to carry the operator and a passenger.
3. The failure of motorists to detect and recognize motorcycles in traffic is the predominating cause of automobile/motorcycle accidents. Many accidents have been caused by an automobile driver who did not see the motorcycle. Making yourself conspicuous appears to be very effective in reducing the chance of this type of accident.

Therefore:

- a. Wear a brightly colored jacket.
- b. Use extra caution when you approach and pass through intersections, since intersections are the most likely places for motorcycle accidents.
- c. Ride where other motorists can see you. Avoid riding in another motorist's "blind spot".

4. Many accidents involve inexperienced operators. In fact, many operators who have been involved in accidents do not even have a current motorcycle license.
  - a. Make sure you are qualified. Also, only lend your motorcycle to experienced operators.
  - b. Know your skills and limits. Staying within your limits may help you to avoid an accident.
  - c. We recommend that you practice riding your motorcycle where there is no traffic until you have become thoroughly familiar with your motorcycle and all of its controls.
5. Many motorcycle accidents have been caused by motorcycle operator errors. A typical error made by the operator is veering wide on a turn due to EXCESSIVE SPEED or undercornering (insufficient lean angle for the speed).
  - a. Always obey the speed limits and never travel faster than warranted by road and traffic conditions.
  - b. Always signal before turning or changing lanes. Make sure other motorists see you.
6. The operator's and passenger's posture are important for proper control.
  - a. The operator should keep both hands on the handlebars and both feet on the operator footrests during operation to maintain control of the motorcycle.
  - b. The passenger should always hold on to the operator, or the seat strap or grab bar if the motorcycle is so equipped, with both hands and keep both feet on the passenger footrests.
  - c. Never carry a passenger unless he or she can firmly place both feet on the passenger footrests.
7. Never ride under the influence of alcohol or drugs.
8. This motorcycle is designed for on-road use only. It is not suitable for off-road use.



# SAFETY INFORMATION

---

---

1

## Protective apparel

The majority of fatalities from motorcycle accidents are the result of head injuries. The use of a safety helmet is the single most critical factor in the prevention or reduction of head injuries.

1. Always wear an approved helmet.
2. Wear a face shield or goggles. Wind on your unprotected eyes could contribute to an impairment of vision which could delay seeing a hazard.
3. The use of heavy boots, jacket, trousers, gloves, etc. is effective in preventing or reducing abrasions or lacerations.
4. Never wear loose fitting clothing. It could catch on the control levers, footrests, or wheels and cause injury or accident.
5. Never touch the engine or exhaust system during or after operation. They become very hot and can cause burns. Always wear protective clothing that covers your legs, ankles, and feet.
6. A passenger should also observe the above precautions.

## Modification

Modifications made to the motorcycle not approved by Yamaha, or the removal of original equipment, may render your motorcycle unsafe for use and may cause severe personal injury. Modifications may also make your motorcycle illegal to use.

## Loading and accessories

Adding accessories or cargo to your motorcycle can adversely affect stability and handling if the weight distribution of the machine is changed. To avoid the possibility of an accident, extreme caution should be used if adding cargo or accessories to your motorcycle. Use extra care if riding a motorcycle which has added cargo or accessories. Here are some general guidelines to follow if loading cargo or adding accessories to your motorcycle:

## Loading

The total weight of the operator, passenger, accessories and cargo must not exceed the maximum load limit of 180 kg: XVS650 / 201 kg: XVS650A.

When loading within these weight limits, keep the following in mind:

1. Cargo and accessory weight should be kept as low and close to the motorcycle as possible. Be sure to distribute the weight as evenly as possible on both sides of the machine to minimize imbalance or instability.
2. Shifting weights can create a sudden imbalance. Make sure that accessories and cargo are securely attached to the motorcycle before riding. Recheck accessory mounts and cargo restraints frequently.
3. Never attach any large or heavy items to the handlebars, front forks, or front fender. These items, including such cargo as sleeping bags, duffle bags, or tents, can create unstable handling or slow steering response.

## Accessories

Genuine Yamaha accessories have been specifically designed for use on this motorcycle. Since Yamaha cannot test all other accessories which may be available, you must personally be responsible for the proper selection, installation and use of non-Yamaha accessories. You should use extreme caution when selecting and installing any accessories.

Keep in mind these guidelines for mounting accessories in addition to those provided under "LOADING".

1. Never install accessories or carry cargo that would impair the performance of your motorcycle. Carefully inspect the accessory before using it to make sure it does not in any way reduce ground clearance or cornering clearance, limit suspension travel, steering travel or control operation, or obscure lights or reflectors.





# SAFETY INFORMATION

---

---

- a. Accessories fitted to the handlebar or the front fork area can create instability due to improper weight distribution or aerodynamic changes. If accessories are added to the handlebar or front fork area, they must be as lightweight as possible and should be kept to a minimum.
  - b. Bulky or large accessories may seriously affect the stability of the motorcycle due to aerodynamic effects. Wind may attempt to lift the motorcycle, or the motorcycle may become unstable in cross winds. These accessories may also cause instability when being passed by or passing large vehicles.
  - c. Certain accessories can displace the operator from his or her normal riding position. This improper position limits the freedom of movement of the operator and may limit control ability. Therefore such accessories are not recommended.
2. Caution must be used if adding electrical accessories. If these accessories exceed the capacity of the motorcycle's electrical system, an electric failure could result, which could cause a dangerous loss of lights or engine power.

## Gasoline and exhaust gas

1. GASOLINE IS HIGHLY FLAMMABLE:
  - a. Always turn off the engine when refueling.
  - b. Take care not to spill any gasoline on the engine or exhaust system when refueling.
  - c. Never refuel while smoking or in the vicinity of an open flame.
2. Never start the engine or let it run for any length of time in a closed area. The exhaust fumes are poisonous and may cause loss of consciousness and death within a short time. Always operate your motorcycle in an area that has adequate ventilation.
3. Always turn off the engine before leaving the motorcycle unattended and remove the ignition key. When parking the motorcycle, note the following:

- a. The engine and exhaust system may be hot. Park the motorcycle in a place where pedestrians or children are not likely to touch these hot areas.
  - b. Do not park the motorcycle on a slope or soft ground; the motorcycle may fall over.
  - c. Do not park the motorcycle near a flammable source, e.g. a kerosene heater, or near an open flame. The motorcycle could catch fire.
4. When transporting the motorcycle in another vehicle, be sure it is kept upright and that the fuel cock is turned to “ON” or “RES” (for vacuum type) / “OFF” (for manual type). If it should lean over, gasoline may leak out of the carburetor or fuel tank.
  5. If you should swallow any gasoline, inhale a lot of gasoline vapor, or allow gasoline to get in your eyes, see your doctor immediately. If any gasoline spills on your skin or clothing, immediately wash it off with soap and water and change your clothes.

# SAFETY INFORMATION

EAU02977

## Location of the important labels

Please read the following labels carefully before operating this motorcycle.

1

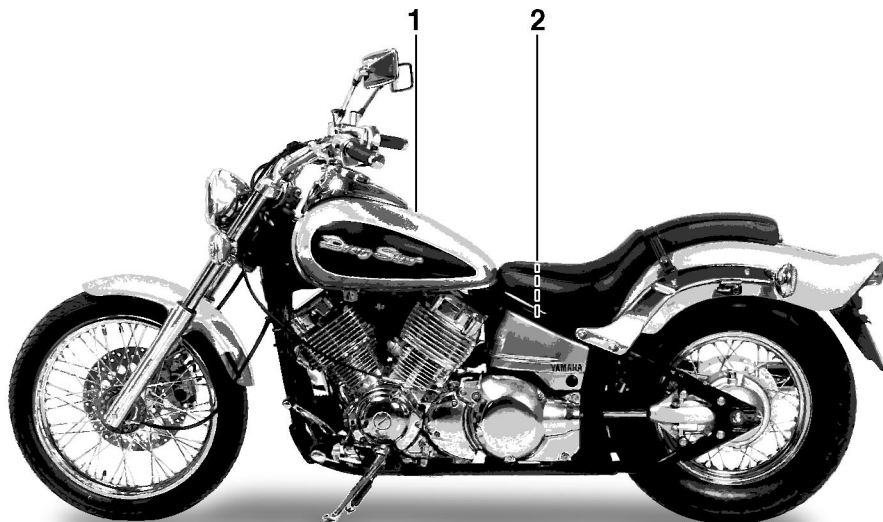

1

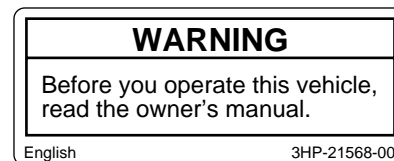

2



Left view (XVS650) .....	2-1
Right view (XVS650) .....	2-2
Left view (XVS650A) .....	2-3
Right view (XVS650A).....	2-4
Controls/Instruments (XVS650/XVS650A).....	2-5

## Left view (XVS650)

2

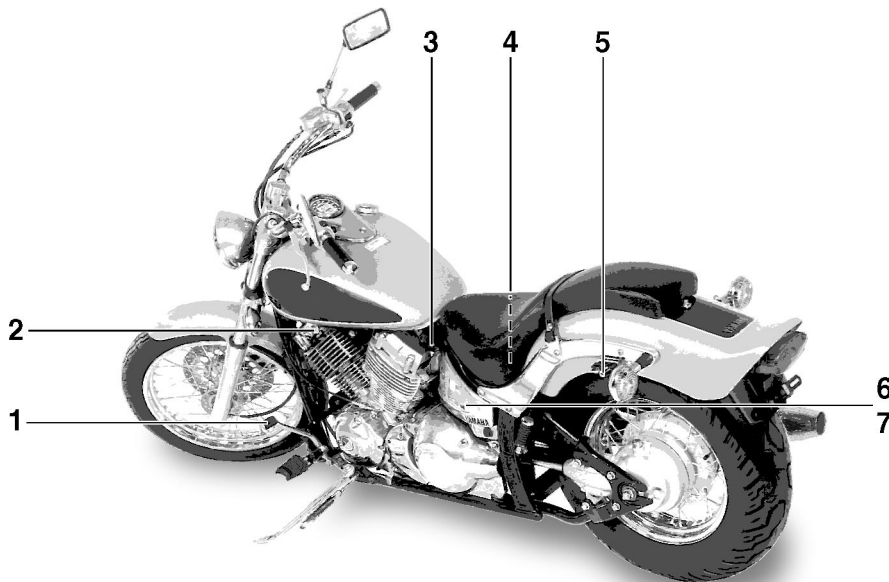

- |  |             |
|--|-------------|
| 1. Shift pedal                                       | (page 3-4)  |
| 2. Fuel cock   | (page 3-7)  |
| 3. Starter (choke) “ ↘ ”                             | (page 3-8)  |
| 4. Rear shock absorber spring preload adjusting ring | (page 3-13) |
| 5. Helmet holder                                     | (page 3-11) |
| 6. Storage compartment                               | (page 3-11) |
| 7. Tool kit  | (page 6-1)  |

## Right view (XVS650)



- |                      |             |
|----------------------|-------------|
| 8. Oil filter        | (page 6-10) |
| 9. Battery           | (page 6-25) |
| 10. Fuses            | (page 6-27) |
| 11. Main switch      | (page 3-1)  |
| 12. Air filter       | (page 6-12) |
| 13. Rear brake pedal | (page 3-5)  |

# DESCRIPTION

---

## Left view (XVS650A)

2

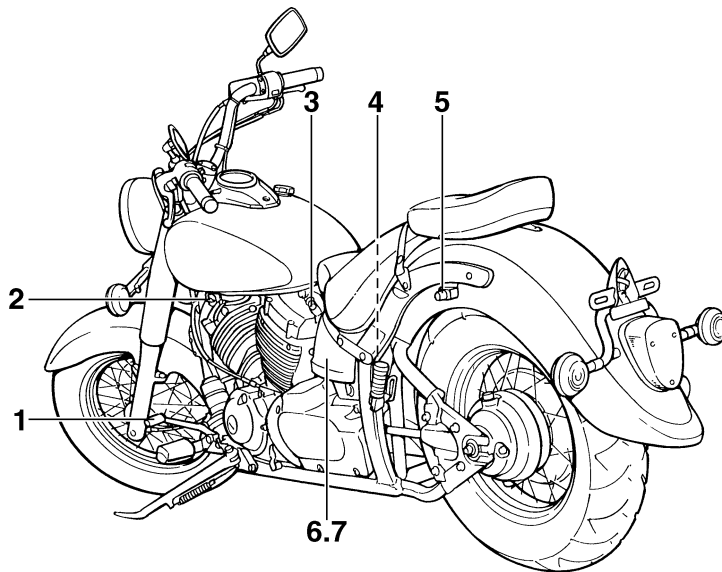

- |  |             |
|--|-------------|
| 1. Shift pedal                                       | (page 3-4)  |
| 2. Fuel cock   | (page 3-7)  |
| 3. Starter (choke) “ ↘ ”                             | (page 3-8)  |
| 4. Rear shock absorber spring preload adjusting ring | (page 3-13) |
| 5. Helmet holder                                     | (page 3-11) |
| 6. Storage compartment                               | (page 3-11) |
| 7. Tool kit  | (page 6-1)  |

## Right view (XVS650A)

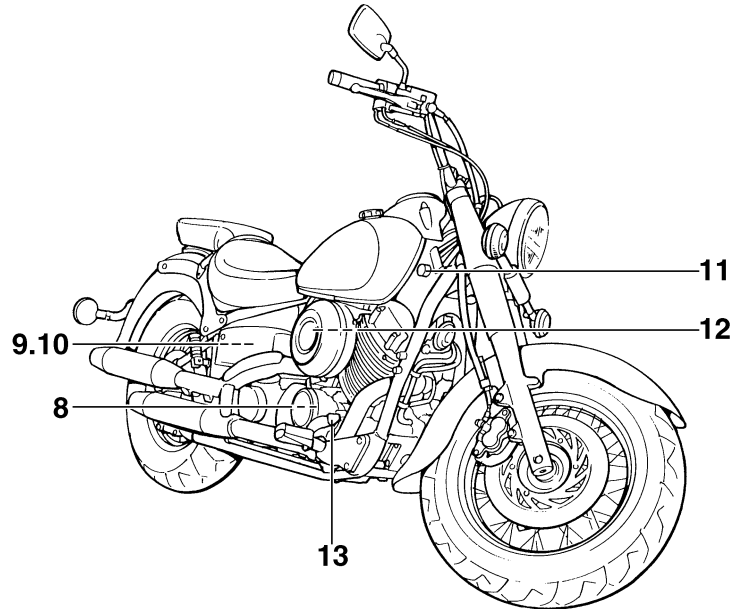

- |                      |             |
|----------------------|-------------|
| 8. Oil filter        | (page 6-10) |
| 9. Battery           | (page 6-25) |
| 10. Fuses            | (page 6-27) |
| 11. Main switch      | (page 3-1)  |
| 12. Air filter       | (page 6-12) |
| 13. Rear brake pedal | (page 3-5)  |



# DESCRIPTION

---

---

## Controls/Instruments (XVS650/XVS650A)

2

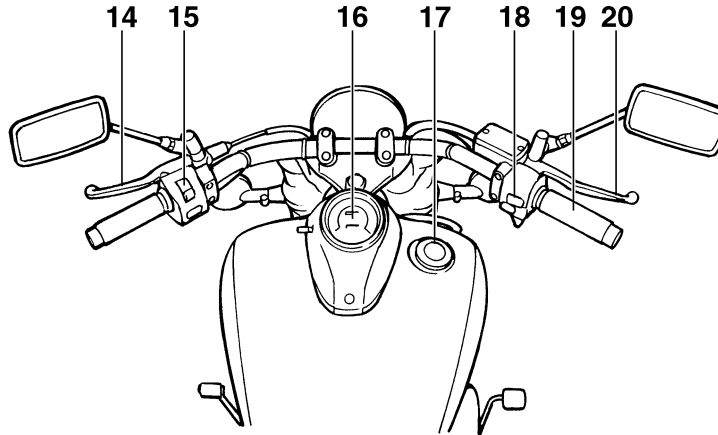

- |                              |             |
|------------------------------|-------------|
| 14. Clutch lever             | (page 3-4)  |
| 15. Left handlebar switches  | (page 3-3)  |
| 16. Speedometer              | (page 3-2)  |
| 17. Fuel tank cap            | (page 3-5)  |
| 18. Right handlebar switches | (page 3-3)  |
| 19. Throttle grip            | (page 6-14) |
| 20. Front brake lever        | (page 3-5)  |

# INSTRUMENT AND CONTROL FUNCTIONS

Main switch/steering lock .....	3-1
Indicator lights .....	3-2
Speedometer.....	3-2
Handlebar switches .....	3-3
Clutch lever .....	3-4
Shift pedal .....	3-4
Front brake lever.....	3-5
Rear brake pedal.....	3-5
Fuel tank cap.....	3-5
Fuel .....	3-6
Fuel cock.....	3-7
Starter (choke) “ ↘ ” .....	3-8
Seats (XVS650) .....	3-9
Seats (XVS650A) .....	3-10
Helmet holder.....	3-11
Storage compartment .....	3-11
Rear shock absorber adjustment .....	3-13
Luggage strap holders .....	3-14
Sidestand .....	3-14
Sidestand/clutch switch operation check.....	3-15

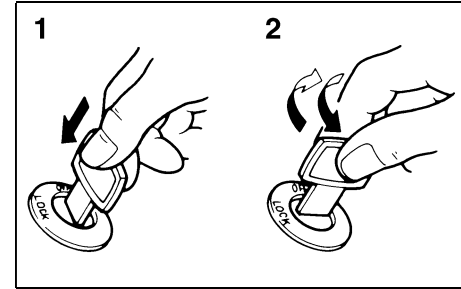
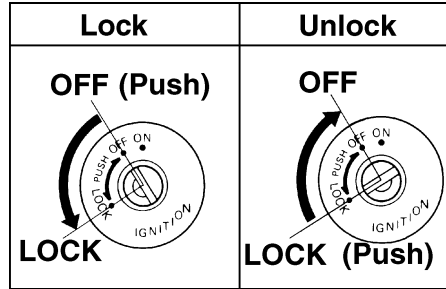
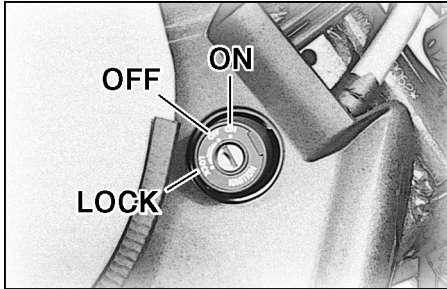

1. Push
2. Turn

EAU00029\*

## Main switch/steering lock

The main switch controls the ignition and lighting systems. Its operation is described below.

EAU00036

### ON

Electrical circuits are switched on. The engine can be started. The key cannot be removed in this position.

EAU00038

### OFF

All electrical circuits are switched off. The key can be removed in this position.

EAU00040

## LOCK

The steering is locked in this position and all electrical circuits are switched off. The key can be removed in this position.

To lock the steering, turn the handlebars all the way to the left. While pushing the key into the main switch, turn it from "OFF" to "LOCK" and remove it. To release the lock, turn the key to "OFF" while pushing.

EW000016

## **! WARNING**

**Never turn the key to "OFF" or "LOCK" when the motorcycle is moving. The electrical circuits will be switched off which may result in loss of control or an accident. Be sure the motorcycle is stopped before turning the key to "OFF" or "LOCK".**

# INSTRUMENT AND CONTROL FUNCTIONS

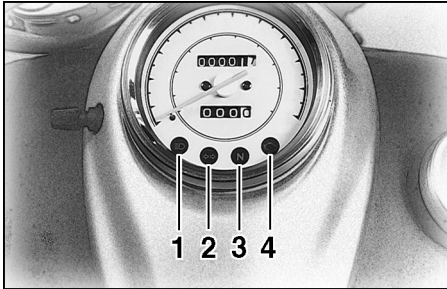

1. High beam indicator light “ $\equiv\bigcirc$ ”
2. Turn indicator light “ $\leftarrow\rightarrow$ ”
3. Neutral indicator light “**N**”
4. Engine trouble indicator light “ $\text{H}\text{C}\text{H}$ ”

## Indicator lights

EAU00056

### High beam indicator light “ $\equiv\bigcirc$ ”

EAU00063

This indicator comes on when the headlight high beam is used.

### Turn indicator light “ $\leftarrow\rightarrow$ ”

EAU00057

This indicator flashes when the turn switch is moved to the left or right.

### Neutral indicator light “**N**”

EAU00061

This indicator comes on when the transmission is in neutral.

### Engine trouble indicator light “ $\text{H}\text{C}\text{H}$ ”

EAU00091

This indicator light will come on or flash if trouble occurs in a monitoring circuit. In such a case, take the motorcycle to a Yamaha dealer to have the self-diagnostic systems checked.

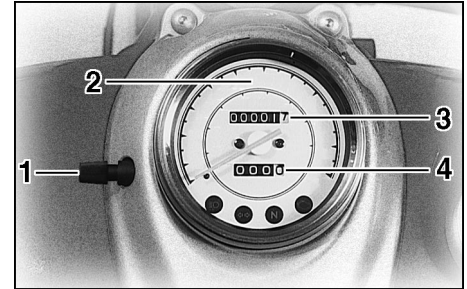

1. Reset knob
2. Speedometer
3. Odometer
4. Trip odometer

## Speedometer

EAU00095

The speedometer shows riding speed. This speedometer is equipped with an odometer and trip odometer. The trip odometer can be reset to “0” with the reset knob. Use the trip odometer to estimate how far you can ride on a tank of fuel. This information will enable you to plan fuel stops in the future.

# INSTRUMENT AND CONTROL FUNCTIONS

3

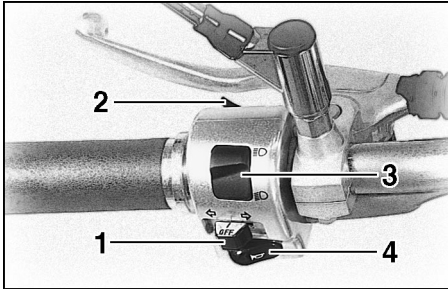

1. Turn signal switch
2. Pass switch “≡D”
3. Dimmer switch
4. Horn switch “📣”

EAU00118

## Handlebar switches

EAU00127

### Turn signal switch

To signal a right-hand turn, push the switch to “>”. To signal a left-hand turn, push the switch to “<”. Once the switch is released it will return to the center position. To cancel the signal, push the switch in after it has returned to the center position.

### Pass switch “≡D”

EAU00119

Press the switch to operate the passing light.

### Dimmer switch

EAU00121

Turn the switch to “≡D” for the high beam and to “D” for the low beam.

### Horn switch “📣”

EAU00129

Press the switch to sound the horn.

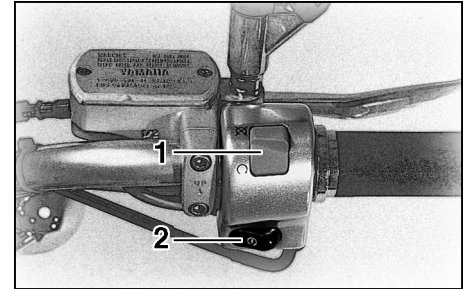

1. Engine stop switch
2. Start switch “⊗”

EAU00138

### Engine stop switch

The engine stop switch is a safety device for use in an emergency such as when the motorcycle overturns or if trouble occurs in the throttle system. Turn the switch to “○” to start the engine. In case of emergency, turn the switch to “⊗” to stop the engine.

# INSTRUMENT AND CONTROL FUNCTIONS

## Start switch “”

The starter motor cranks the engine when pushing the start switch.

EAU00143

EC000005

### CAUTION:

See starting instructions prior to starting the engine.

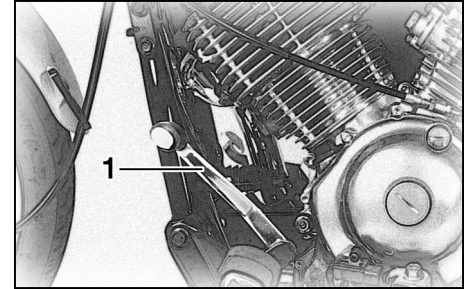
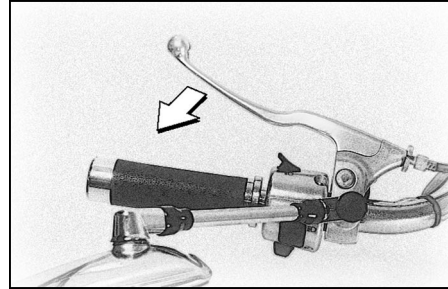

1. Shift pedal

## Clutch lever

The clutch lever is located on the left handlebar, and the ignition circuit cut-off system is incorporated in the clutch lever holder. Pull the clutch lever to the handlebar to disengage the clutch, and release the lever to engage the clutch. The lever should be pulled rapidly and released slowly for smooth clutch operation. (Refer to the engine starting procedures for a description of the ignition circuit cut-off system.)

EAU00152

## Shift pedal

This motorcycle is equipped with a constant-mesh 5-speed transmission. The shift pedal is located on the left side of the engine and is used in combination with the clutch when shifting.

EAU00157

# INSTRUMENT AND CONTROL FUNCTIONS

3

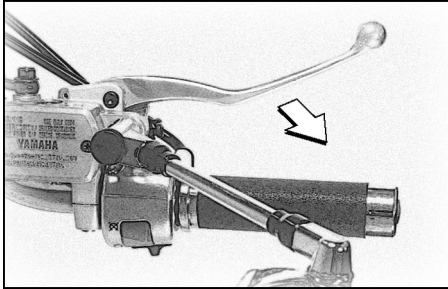

EAU00158

## Front brake lever

The front brake lever is located on the right handlebar. Pull it toward the handlebar to apply the front brake.

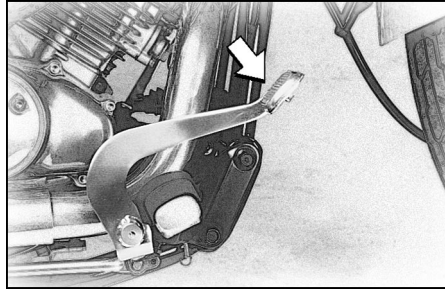

EAU00162

## Rear brake pedal

The rear brake pedal is on the right side of the motorcycle. Press down on the brake pedal to apply the rear brake.

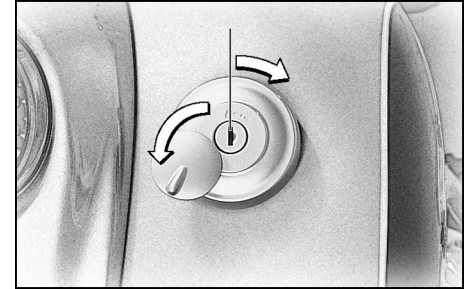

EAU00167

## Fuel tank cap

### To open

Insert the key and turn it 1/4 turn clockwise. The lock will be released and the cap can be opened.

### To close

Push the tank cap into position with the key inserted. To remove the key, turn it counterclockwise to the original position.

# INSTRUMENT AND CONTROL FUNCTIONS

EAU00185

## NOTE:

This tank cap cannot be closed unless the key is in the lock. The key cannot be removed if the cap is not locked properly.

EW000023

## WARNING

Be sure the cap is properly installed and locked in place before riding the motorcycle.

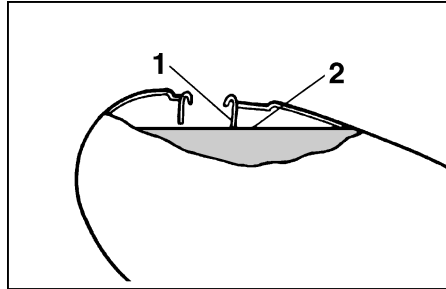

1. Filler tube
2. Fuel level

EAU01183

## Fuel

Make sure there is sufficient fuel in the tank. Fill the fuel tank to the bottom of the filler tube as shown in the illustration.

EW000130

## WARNING

Do not overfill the fuel tank. Avoid spilling fuel on the hot engine. Do not fill the fuel tank above the bottom of the filler tube or it may overflow when the fuel heats up later and expands.

## CAUTION:

Always wipe off spilled fuel immediately with a dry and clean soft cloth. Fuel may deteriorate painted surfaces or plastic parts.

EAU00192

Recommended fuel:

Regular gasoline

For Australia:

Unleaded fuel only

Fuel tank capacity:

Total:

16 L

Reserve:

3 L



# INSTRUMENT AND CONTROL FUNCTIONS

3

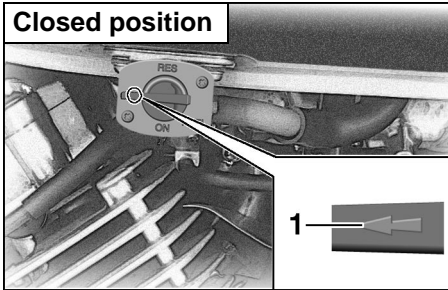

1. Arrow mark over "OFF"

EAU02969

## Fuel cock

The fuel cock supplies fuel from the tank to the carburetors while filtering it also.

The fuel cock has three positions, which should be set as shown in the illustrations.

### OFF

With the fuel cock in this position, fuel will not flow. Always set the fuel cock to this position when the engine is not running.

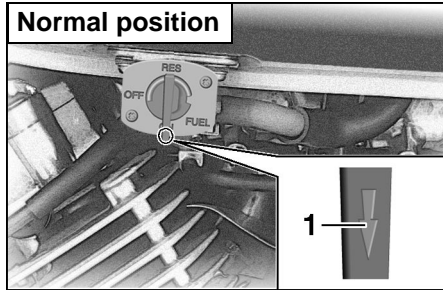

1. Arrow mark over "ON"

### ON

With the fuel cock in this position, fuel flows to the carburetors. Set the fuel cock to this position when starting the engine and while riding.

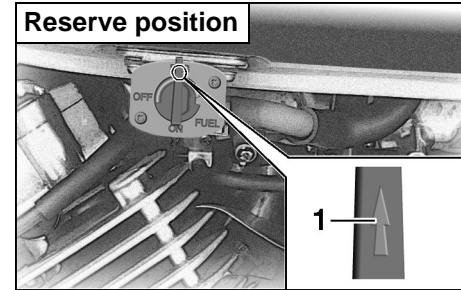

1. Arrow mark over "RES"

### RES

This indicates reserve. If you run out of fuel while riding, set the fuel cock to this position. Fill the tank at the first opportunity. Be sure to set the fuel cock back to "ON" after refueling!

ECA00038

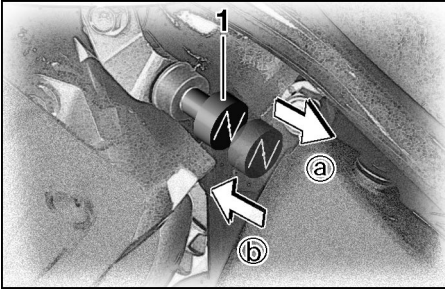

1. Starter (choke) “|↘|”

EAU02973

## Starter (choke) “|↘|”

Starting a cold engine requires a richer air-fuel mixture. A separate starter circuit supplies this mixture.

Move in direction ① to turn on the starter (choke).

Move in direction ② to turn off the starter (choke).

### CAUTION:

Do not use the starter (choke) for more than 3 minutes as the exhaust pipe may discolor from excessive heat. Also, longer use of the starter (choke) will cause afterburning. If afterburning occurs, turn off the starter (choke).

# INSTRUMENT AND CONTROL FUNCTIONS

XVS650

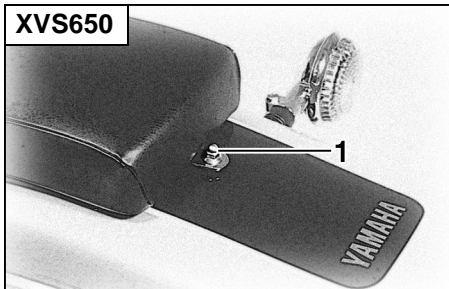

1. Nut

EAU01889

## Seats (XVS650)

### Passenger seat

#### To remove

Remove the nut and pull the seat upward.

XVS650

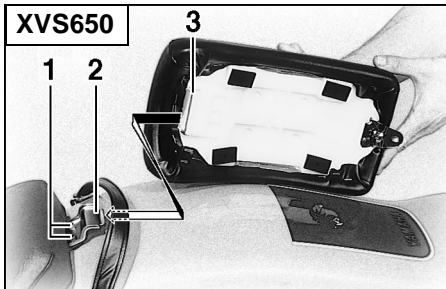

1. Bolt (× 2)
2. Seat holder
3. Projection

#### To install

Insert the projection on the front of the seat into the seat holder and install the bolts.

### Rider seat

#### To remove

1. Remove the passenger seat.
2. Remove the two bolts and pull the seat upward.

XVS650

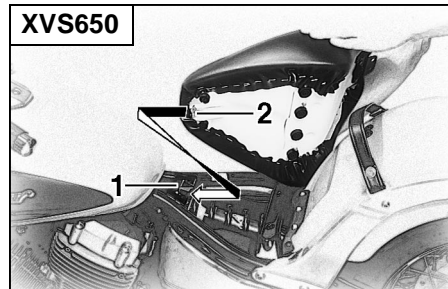

1. Seat holder
2. Projection

#### To install

1. Insert the projection on the front of the seat into the seat holder and install the bolts.
2. Install the passenger seat.

**NOTE:** \_\_\_\_\_  
Make sure that the seats are securely fitted.  
\_\_\_\_\_

# INSTRUMENT AND CONTROL FUNCTIONS

XVS650A

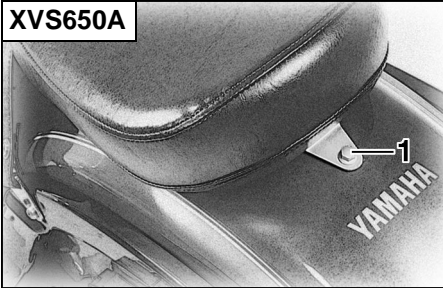

1. Bolt

EAU01888

## Seats (XVS650A)

### Passenger seat

#### To remove

Remove the bolt and pull the seat upward.

XVS650A

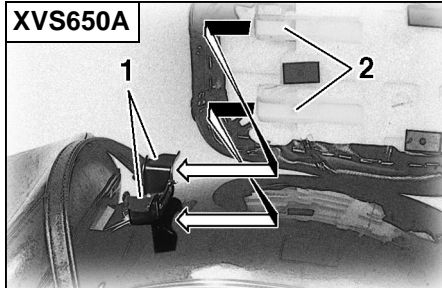

1. Seat holder (× 2)
2. Projection (× 2)

#### To install

Insert the projections on the front of the seat into the holder and install the bolt.

XVS650A

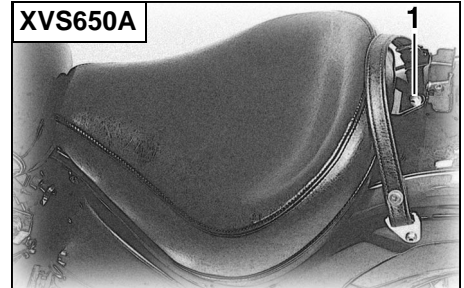

1. Bolt

### Rider seat

#### To remove

1. Remove the passenger seat.
2. Remove the bolt and pull the seat upward.

# INSTRUMENT AND CONTROL FUNCTIONS

XVS650A

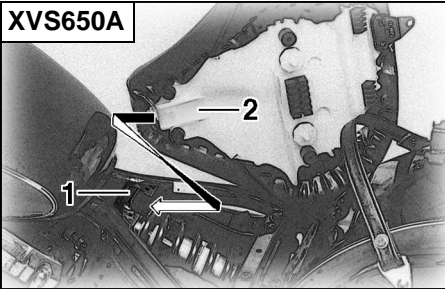

1. Seat holder
2. Projection

## To install

1. Insert the projection on the front of the seat into the holder and install the bolt.
2. Install the passenger seat.

## NOTE:

Make sure that the seats are securely fitted.

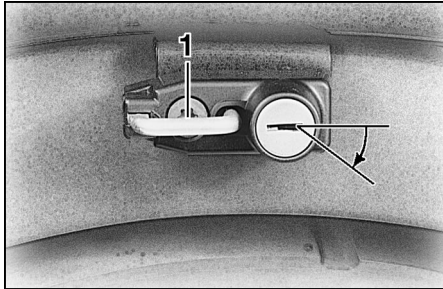

1. Helmet holder

EAU00260

## Helmet holder

To open the helmet holder, insert the key in the lock and turn it as shown. To lock the helmet holder, replace the holder in its original position.

EW000030



**Never ride with a helmet in the helmet holder. The helmet may hit objects, causing loss of control and possibly an accident.**

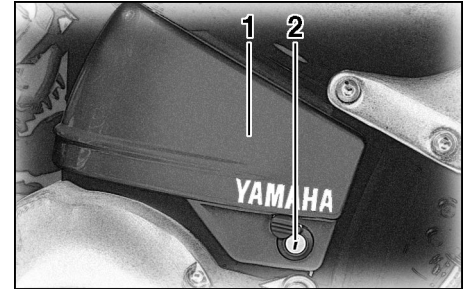

1. Compartment cover
2. Lock

EAU01869

## Storage compartment

The storage compartment is located on the left side of the motorcycle.

# INSTRUMENT AND CONTROL FUNCTIONS

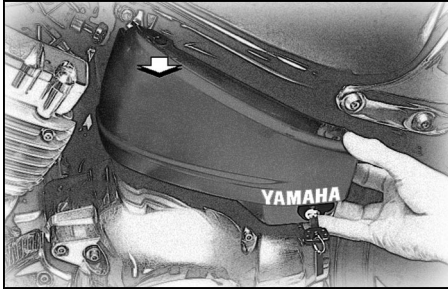

## To open

Slide the lock cover open, insert the key in the lock and turn it clockwise. Then, pull the storage compartment cover out as shown.

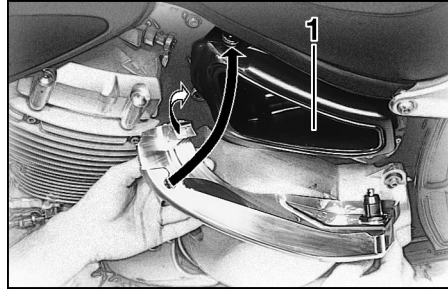

1. Storage compartment

## To close

Place the storage compartment cover in its original position as shown. Then, turn the key counterclockwise and remove it. Close the lock cover.

# INSTRUMENT AND CONTROL FUNCTIONS

EAU00315

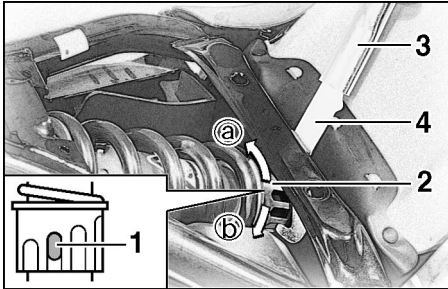

1. Position indicator
2. Adjusting ring
3. Extension bar
4. Special wrench

EAU00299

## Rear shock absorber adjustment

This shock absorber is equipped with a spring preload adjuster. Adjust spring preload as follows:

1. Remove the passenger seat and rider seat. (See page 3-9 for removal procedures.)

2. Use the special wrench and the extension bar in the owner's tool kit to turn the adjusting ring. Turn the adjusting ring in direction **a** to increase spring preload and in direction **b** to decrease spring preload. Make sure that the appropriate notch in the adjusting ring is aligned with the position indicator on the rear shock absorber.

	Soft		Standard	Hard			
Adjusting position	1	2	3	4	5	6	7

3. Reinstall the seats.

### **! WARNING**

This shock absorber contains highly pressurized nitrogen gas. Read and understand the following information before handling the shock absorber. The manufacturer cannot be held responsible for property damage or personal injury that may result from improper handling.

- Do not tamper with or attempt to open the cylinder assembly.
- Do not subject the shock absorber to an open flame or other high heat source. This may cause the unit to explode due to excessive gas pressure.
- Do not deform or damage the cylinder in any way. Cylinder damage will result in poor damping performance.
- Take your shock absorber to a Yamaha dealer for any service.

EAU00330

EW000044

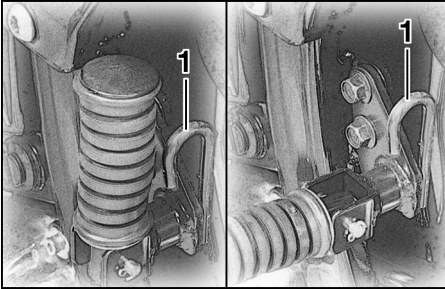

1. Luggage strap holder (× 2)

EAU01172

## Luggage strap holders

There is a luggage strap holder located at each passenger footrest.

## Sidestand

This model is equipped with an ignition circuit cut-off system. The motorcycle must not be ridden when the sidestand is down. The sidestand is located on the left side of the frame. (Refer to page 5-1 for an explanation of this system.)

### **WARNING**

**This motorcycle must not be operated with the sidestand in the down position. If the stand is not properly retracted, it could contact the ground and distract the operator, resulting in a possible loss of control. Yamaha has designed into this motorcycle a lockout system to assist the operator in fulfilling the responsibility of retracting the sidestand. Please check carefully the operating instructions listed below and if there is any indication of a malfunction, return the motorcycle to a Yamaha dealer immediately for repair.**



# INSTRUMENT AND CONTROL FUNCTIONS

EAU00331

## Sidestand/clutch switch operation check

Check the operation of the sidestand switch and clutch switch against the information below.

3  
TURN THE MAIN SWITCH TO "ON" AND THE ENGINE STOP SWITCH TO "O".

TRANSMISSION IS IN GEAR AND SIDESTAND IS UP.

PULL IN CLUTCH LEVER AND PUSH THE START SWITCH.

ENGINE WILL START.

CLUTCH SWITCH IS OK.

SIDESTAND IS DOWN.

ENGINE WILL STALL.

SIDESTAND SWITCH IS OK.

EW000045

### WARNING

**If improper operation is noted, consult a Yamaha dealer immediately.**

Pre-operation check list..... 4-1

# PRE-OPERATION CHECKS

Owners are personally responsible for their vehicle's condition. Your motorcycle's vital functions can start to deteriorate quickly and unexpectedly, even if it remains unused (for instance, if it is exposed to the elements). Any damage, fluid leak or loss of tire pressure could have serious consequences. Therefore, it is very important that, in addition to a thorough visual inspection, you check the following points before each ride.

## PRE-OPERATION CHECK LIST

ITEM	CHECKS	PAGE
Front brake	<ul style="list-style-type: none"><li>• Check operation, free play, fluid level and vehicle for fluid leakage.</li><li>• Fill with DOT 4 brake fluid if necessary.</li></ul>	6-18 ~ 6-22
Rear brake	<ul style="list-style-type: none"><li>• Check operation, condition and free play.</li><li>• Adjust if necessary.</li></ul>	6-19 ~ 6-22
Clutch	<ul style="list-style-type: none"><li>• Check operation condition and free play.</li><li>• Adjust if necessary.</li></ul>	6-17 ~ 6-18
Throttle grip and housing	<ul style="list-style-type: none"><li>• Check for smooth operation.</li><li>• Lubricate if necessary.</li></ul>	6-14, 6-23
Engine oil	<ul style="list-style-type: none"><li>• Check oil level.</li><li>• Fill with oil if necessary.</li></ul>	6-9 ~ 6-11
Final gear oil	<ul style="list-style-type: none"><li>• Check vehicle for leakage.</li></ul>	6-11 ~ 6-12
Wheels and tires	<ul style="list-style-type: none"><li>• Check tire pressure, wear, damage and spoke tightness.</li><li>• Tighten spokes if necessary.</li></ul>	6-15 ~ 6-17, 6-25, 6-30 ~ 6-33
Control and meter cable	<ul style="list-style-type: none"><li>• Check for smooth operation.</li><li>• Lubricate if necessary.</li></ul>	6-22
Brake and shift pedal shafts	<ul style="list-style-type: none"><li>• Check for smooth operation.</li><li>• Lubricate if necessary.</li></ul>	6-23
Brake and clutch lever pivots	<ul style="list-style-type: none"><li>• Check for smooth operation.</li><li>• Lubricate if necessary.</li></ul>	6-23
Sidestand pivot	<ul style="list-style-type: none"><li>• Check for smooth operation.</li><li>• Lubricate if necessary.</li></ul>	6-24
Chassis fasteners	<ul style="list-style-type: none"><li>• Make sure that all nuts, bolts and screws are properly tightened.</li><li>• Tighten if necessary.</li></ul>	—

# PRE-OPERATION CHECKS

ITEM	CHECKS	PAGE
Fuel	<ul style="list-style-type: none"><li>• Check fuel level.</li><li>• Fill with fuel if necessary.</li></ul>	3-6
Lights, signals and switches	<ul style="list-style-type: none"><li>• Check for proper operation.</li></ul>	6-28 ~ 6-29

**NOTE:**

Pre-operation checks should be made each time the motorcycle is used. Such an inspection can be thoroughly accomplished in a very short time; and the added safety it assures is more than worth the time involved.

**⚠ WARNING**

If any item in the Pre-Operation Check is not working properly, have it inspected and repaired before operating the motorcycle.



# OPERATION AND IMPORTANT RIDING POINTS

---

Starting and warming up a cold engine.....	5-1
Starting a warm engine .....	5-4
Shifting .....	5-4
Tips for reducing fuel consumption .....	5-5
Engine break-in .....	5-5
Parking .....	5-6

EAU00373

EAU01860

**! WARNING**

- Before riding this motorcycle, become thoroughly familiar with all operating controls and their functions. Consult a Yamaha dealer regarding any control or function that you do not thoroughly understand.
- Never start your engine or let it run for any length of time in a closed area. The exhaust fumes are poisonous and can cause loss of consciousness and death within a short time. Always operate your motorcycle in an area with adequate ventilation.
- Before starting out, always be sure the sidestand is up. Failure to retract the sidestand completely can result in a serious accident when you try to turn a corner.

## Starting and warming up a cold engine

**NOTE:**

This motorcycle is equipped with an ignition circuit cut-off system. The engine can be started only under one of the following conditions:

- The transmission is in neutral.
- The sidestand is up, the transmission is in gear and the clutch is disengaged.

The motorcycle must not be ridden when the sidestand is down.

EW000054

**! WARNING**

Before going through the following steps, check the function of the sidestand switch and clutch switch. (Refer to page 3-15.)

# OPERATION AND IMPORTANT RIDING POINTS

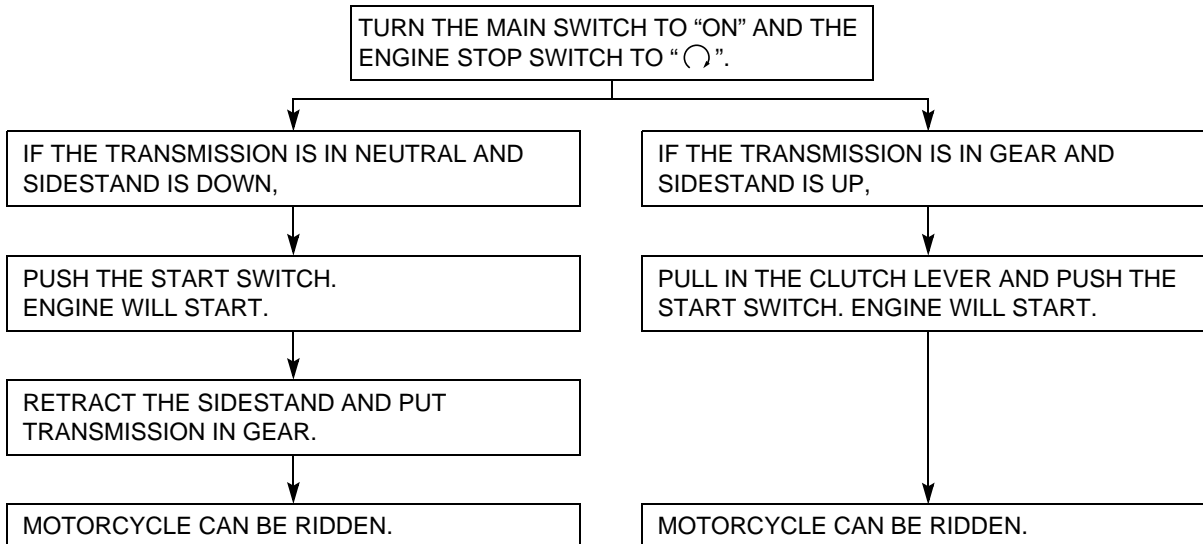



# OPERATION AND IMPORTANT RIDING POINTS

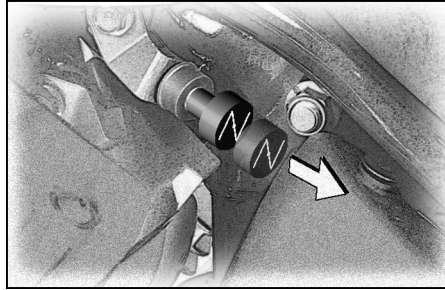
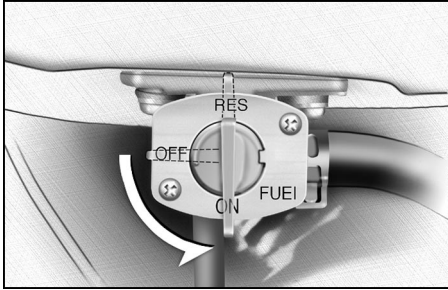

1. Turn the fuel cock to "ON".
2. Turn the main switch to "ON" and the engine stop switch to "⊙".
3. Shift transmission into neutral.

**NOTE:** \_\_\_\_\_  
When the transmission is in neutral, the neutral indicator light should be on. If the light does not come on, ask a Yamaha dealer to inspect it.

4. Turn on the starter (choke) "1/2" and completely close the throttle grip.
5. Start the engine by pushing the start switch.

7. After warming up the engine, turn off the starter (choke) completely.

**NOTE:** \_\_\_\_\_  
The engine is warm when it responds normally to the throttle with the starter (choke) turned off.

**NOTE:** \_\_\_\_\_  
If the engine fails to start, release the start switch, wait a few seconds, then try again. Each attempt should be as short as possible to preserve the battery. Do not crank the engine more than 10 seconds on any one attempt.

6. After starting the engine, move the starter (choke) "1/2" to the halfway position.

**NOTE:** \_\_\_\_\_  
For maximum engine life, never accelerate hard with a cold engine!

# OPERATION AND IMPORTANT RIDING POINTS

## Starting a warm engine

EAU01258

The starter (choke) is not required when the engine is warm.

EC000046

### CAUTION:

See the “Engine break-in” section prior to operating the motorcycle for the first time.

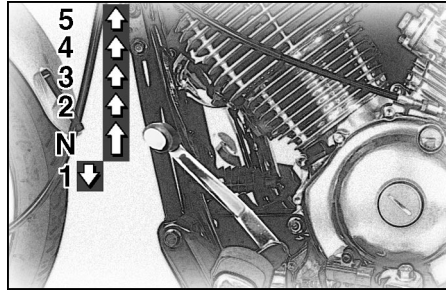

EAU00423

## Shifting

The transmission lets you control the amount of power you have available at a given speed for starting, accelerating, climbing hills, etc. The use of the shift pedal is shown in the illustration.

To shift into neutral, depress the shift pedal repeatedly until it reaches the end of its travel, then raise the pedal slightly.

EC000048

### CAUTION:

- Do not coast for long periods with the engine off, and do not tow the motorcycle a long distance. Even with gears in neutral, the transmission is only properly lubricated when the engine is running. Inadequate lubrication may damage the transmission.
- Always use the clutch when changing gears. The engine, transmission, and driveline are not designed to withstand the shock of forced shifting and can be damaged by shifting without using the clutch.

# OPERATION AND IMPORTANT RIDING POINTS

---

---

## Tips for reducing fuel consumption

EAU00424

Your motorcycle's fuel consumption depends to a large extent on your riding style. The following tips can help reduce fuel consumption:

- Warm up the engine before riding.
- Turn off the starter (choke) as soon as possible.
- Shift up swiftly and avoid high engine speeds during acceleration.
- Do not double-clutch or rev the engine while shifting down and avoid high engine speeds with no load on the engine.
- Turn off the engine instead of letting it idle for an extended length of time, i.e. in traffic jams, at traffic lights or railroad crossings.

## Engine break-in

EAU01128

There is never a more important period in the life of your motorcycle than the period between zero and 1,600 km. For this reason we ask that you carefully read the following material. Because the engine is brand new, you must not put an excessive load on it for the first 1,600 km. The various parts in the engine wear and polish themselves to the correct operating clearances. During this period, prolonged full throttle operation, or any condition which might result in excessive heating of the engine, must be avoided.

## 0 ~ 1,000 km

EAU01171

Avoid operation above 1/3 throttle.

## 1,000 ~ 1,600 km

Avoid cruising speeds in excess of 1/2 throttle.

EC000056

### **CAUTION:** \_\_\_\_\_

**After 1,000 km of operation, be sure to replace the engine oil, oil filter and final gear oil.**

---

## 1,600 km and beyond

Proceed with normal riding.

EC000049

### **CAUTION:** \_\_\_\_\_

**If any engine trouble should occur during the break-in period, consult a Yamaha dealer immediately.**

---

EAU00457

## Parking

When parking the motorcycle, stop the engine and remove the ignition key. Turn the fuel cock to “OFF” whenever stopping the engine.

EW000058

### **WARNING**

**The exhaust system is hot. Park the motorcycle in a place where pedestrians or children are not likely to touch the motorcycle. Do not park the motorcycle on a slope or soft ground; the motorcycle may overturn.**

---



# PERIODIC MAINTENANCE AND MINOR REPAIR

Tool kit.....	6-1	Inspecting the brake fluid level .....	6-21
Periodic maintenance and lubrication .....	6-2	Brake fluid replacement .....	6-22
Panel removal and installation .....	6-5	Cable inspection and lubrication .....	6-22
Panel A .....	6-6	Throttle cable and grip lubrication .....	6-23
Panel B .....	6-7	Brake and shift pedal lubrication .....	6-23
Spark plugs.....	6-7	Brake and clutch lever lubrication .....	6-23
Engine oil .....	6-9	Sidestand lubrication.....	6-24
Final gear oil .....	6-11	Front fork inspection.....	6-24
Air filter .....	6-12	Steering inspection .....	6-25
Carburetor adjustment .....	6-13	Wheel bearings .....	6-25
Idle speed adjustment .....	6-14	Battery.....	6-25
Throttle cable free play inspection .....	6-14	Fuse replacement .....	6-27
Valve clearance adjustment.....	6-15	Headlight bulb replacement .....	6-28
Tires.....	6-15	Turn signal and taillight bulb replacement.....	6-29
Wheels.....	6-17	Supporting the motorcycle .....	6-30
Clutch lever free play adjustment.....	6-17	Front wheel removal.....	6-31
Front brake lever free play adjustment.....	6-18	Front wheel installation .....	6-31
Rear brake pedal height and free play adjustment .....	6-19	Rear wheel removal .....	6-32
Brake light switch adjustment .....	6-20	Rear wheel installation .....	6-33
Checking the front brake pads and rear brake shoes.....	6-21	Troubleshooting.....	6-34
		Troubleshooting chart.....	6-35

EAU00464

Periodic inspection, adjustment and lubrication will keep your motorcycle in the safest and most efficient condition possible. Safety is an obligation of the motorcycle owner. The maintenance and lubrication schedule chart should be considered strictly as a guide to general maintenance and lubrication intervals. **YOU MUST TAKE INTO CONSIDERATION THAT WEATHER, TERRAIN, GEOGRAPHICAL LOCATIONS, AND A VARIETY OF INDIVIDUAL USES ALL TEND TO DEMAND THAT EACH OWNER ALTER THIS TIME SCHEDULE TO SHORTER INTERVALS TO MATCH THE ENVIRONMENT.** The most important points of motorcycle inspection, adjustment, and lubrication are explained in the following pages.

EW000060

**⚠ WARNING**

**If you are not familiar with motorcycle service, this work should be done by a Yamaha dealer.**

EAU01129

## Tool kit

The tool kit is located inside the storage compartment. (See page 3-11 for compartment opening procedures.) The tools provided in the owner's tool kit are to assist you in the performance of periodic maintenance. However, some other tools such as a torque wrench are also necessary to perform the maintenance correctly.

The service information included in this manual is intended to provide you, the owner, with the necessary information for completing some of your own preventive maintenance and minor repairs.

**NOTE:**

If you do not have necessary tools required during a service operation, take your motorcycle to a Yamaha dealer for service.

EW000062

**⚠ WARNING**

**Modifications to this motorcycle not approved by Yamaha may cause loss of performance, excessive emissions, and render it unsafe for use. Consult a Yamaha dealer before attempting any changes.**

# PERIODIC MAINTENANCE AND MINOR REPAIR

EAU00473

## PERIODIC MAINTENANCE AND LUBRICATION

NO.	ITEM	CHECKS AND MAINTENANCE JOBS	INITIAL (1,000 km)	EVERY	
				6,000 km or 6 months (whichever comes first)	12,000 km or 12 months (whichever comes first)
1	* Fuel line	<ul style="list-style-type: none"> <li>• Check fuel hoses for cracks or damage.</li> <li>• Replace if necessary.</li> </ul>		√	√
2	Spark plugs	<ul style="list-style-type: none"> <li>• Check condition.</li> <li>• Clean, regap or replace if necessary.</li> </ul>	√	√	√
3	* Valves	<ul style="list-style-type: none"> <li>• Check valve clearance.</li> <li>• Adjust if necessary.</li> </ul>	√	√	√
4	Air filter	<ul style="list-style-type: none"> <li>• Clean or replace if necessary.</li> </ul>		√	√
5	Clutch	<ul style="list-style-type: none"> <li>• Check operation.</li> <li>• Adjust or replace cable.</li> </ul>	√	√	√
6	* Front brake	<ul style="list-style-type: none"> <li>• Check operation, fluid level and vehicle for fluid leakage. (See NOTE on page 6-4.)</li> <li>• Correct accordingly.</li> <li>• Replace brake pads if necessary.</li> </ul>	√	√	√
7	* Rear brake	<ul style="list-style-type: none"> <li>• Check operation.</li> <li>• Adjust brake pedal free play and replace brake shoes if necessary.</li> </ul>	√	√	√
8	* Wheels	<ul style="list-style-type: none"> <li>• Check balance, runout, spoke tightness and for damage.</li> <li>• Tighten spokes and rebalance, replace if necessary.</li> </ul>		√	√
9	* Tires	<ul style="list-style-type: none"> <li>• Check tread depth and for damage.</li> <li>• Replace if necessary.</li> <li>• Check air pressure.</li> <li>• Correct if necessary.</li> </ul>		√	√
10	* Wheel bearings	<ul style="list-style-type: none"> <li>• Check bearing for looseness or damage.</li> <li>• Replace if necessary.</li> </ul>		√	√



# PERIODIC MAINTENANCE AND MINOR REPAIR

NO.	ITEM	CHECKS AND MAINTENANCE JOBS	INITIAL (1,000 km)	EVERY	
				6,000 km or 6 months (whichever comes first)	12,000 km or 12 months (whichever comes first)
11	* <b>Swingarm</b>	<ul style="list-style-type: none"> <li>• Check swingarm pivoting point for play.</li> <li>• Correct if necessary.</li> <li>• Lubricate with molybdenum disulfide grease every 24,000 km or 24 months (whichever comes first).</li> </ul>		√	√
12	* <b>Steering bearings</b>	<ul style="list-style-type: none"> <li>• Check bearing play and steering for roughness.</li> <li>• Correct accordingly.</li> <li>• Lubricate with lithium soap base grease every 24,000 km or 24 months (whichever comes first).</li> </ul>		√	√
13	* <b>Chassis fasteners</b>	<ul style="list-style-type: none"> <li>• Make sure that all nuts, bolts and screws are properly tightened.</li> <li>• Tighten if necessary.</li> </ul>		√	√
14	<b>Sidestand</b>	<ul style="list-style-type: none"> <li>• Check operation.</li> <li>• Lubricate and repair if necessary.</li> </ul>		√	√
15	* <b>Sidestand switch</b>	<ul style="list-style-type: none"> <li>• Check operation.</li> <li>• Replace if necessary.</li> </ul>	√	√	√
16	* <b>Front fork</b>	<ul style="list-style-type: none"> <li>• Check operation and for oil leakage.</li> <li>• Correct accordingly.</li> </ul>		√	√
17	* <b>Rear shock absorber assembly</b>	<ul style="list-style-type: none"> <li>• Check operation and shock absorber for oil leakage.</li> <li>• Replace shock absorber assembly if necessary.</li> </ul>		√	√
18	* <b>Carburetors</b>	<ul style="list-style-type: none"> <li>• Check engine idling speed, synchronization and starter operation.</li> <li>• Adjust if necessary.</li> </ul>	√	√	√
19	<b>Engine oil</b>	<ul style="list-style-type: none"> <li>• Check oil level and vehicle for oil leakage.</li> <li>• Correct if necessary.</li> <li>• Change. (Warm engine before draining.)</li> </ul>	√	√	√
20	<b>Engine oil filter element</b>	<ul style="list-style-type: none"> <li>• Replace.</li> </ul>	√		√

# PERIODIC MAINTENANCE AND MINOR REPAIR

NO.	ITEM	CHECKS AND MAINTENANCE JOBS	INITIAL (1,000 km)	EVERY	
				6,000 km or 6 months (whichever comes first)	12,000 km or 12 months (whichever comes first)
21	Final gear oil	<ul style="list-style-type: none"> <li>• Check oil level and vehicle for oil leakage.</li> <li>• Change oil at initial 1,000 km and thereafter every 24,000 km or 24 months (whichever comes first).</li> </ul>	√	√	√

\* Since these items require special tools, data and technical skills, they should be serviced by a Yamaha dealer.

EAU02970\*

**NOTE:** \_\_\_\_\_

- The air filter needs more frequent service if you are riding in unusually wet or dusty areas.
- Hydraulic brake system
  - When disassembling the master cylinder or caliper cylinder, always replace the brake fluid. Check the brake fluid level regularly and fill as required.
  - Replace the oil seals on the inner parts of the master cylinder and caliper cylinder every two years.
  - Replace the brake hoses every four years or if cracked or damaged.

# PERIODIC MAINTENANCE AND MINOR REPAIR

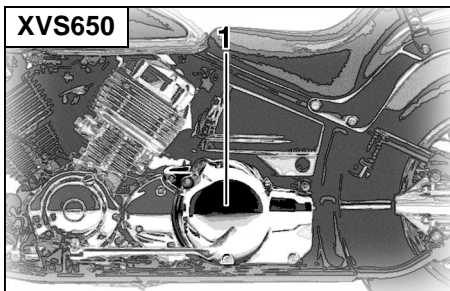

1. Panel A

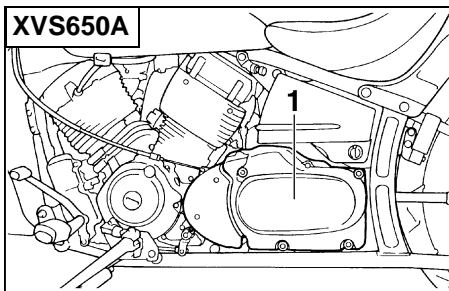

1. Panel A

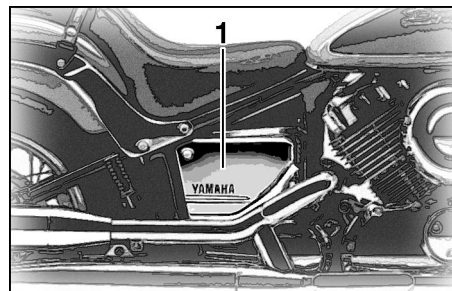

1. Panel B

EAU01122

## Panel removal and installation

The panels illustrated need to be removed to perform some of the maintenance described in this chapter. Refer to this section each time a panel has to be removed or reinstalled.

# PERIODIC MAINTENANCE AND MINOR REPAIR

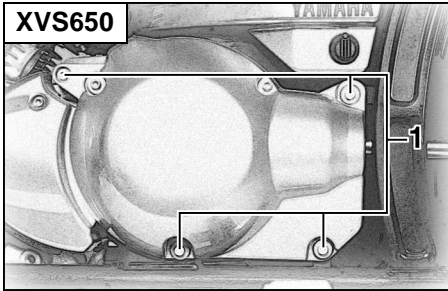

1. Bolt (× 4)

EAU01573

## Panel A

### To remove

Remove the bolts.

### To install

Place the panel in its original position and install the bolts.

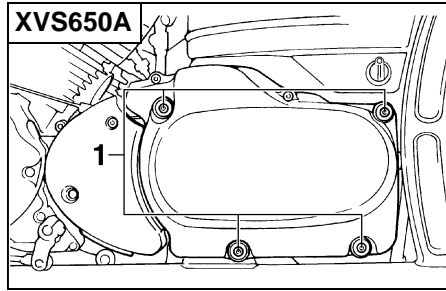

1. Bolt (× 4)

# PERIODIC MAINTENANCE AND MINOR REPAIR

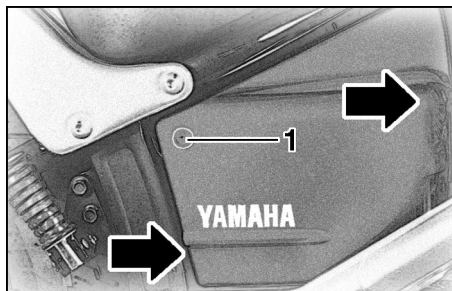

1. Bolt

EAU00491

## Panel B

### To remove

Remove the bolt and pull outward on the areas shown.

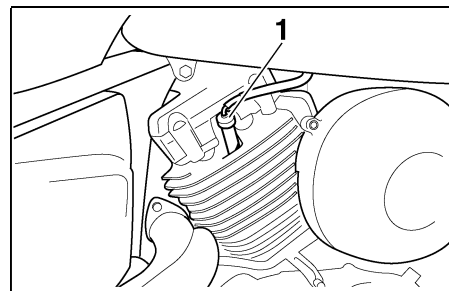
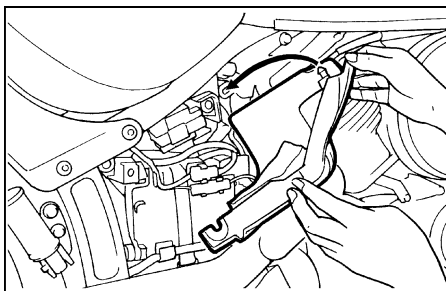

1. Spark plug cap

EAU03053

### To install

Place the panel in its original position and install the bolt.

## Spark plugs

### Removal

1. Remove the spark plug caps.
2. Use the spark plug wrench in the tool kit to remove the spark plugs as shown.

# PERIODIC MAINTENANCE AND MINOR REPAIR

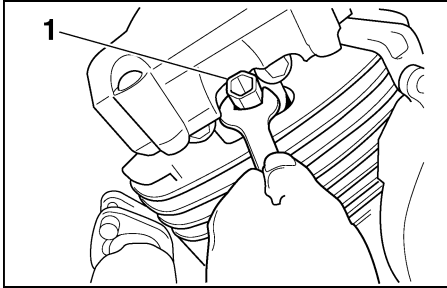

1. Spark plug wrench

## Inspection

The spark plug is an important engine component and is easy to inspect. The condition of the spark plug can indicate the condition of the engine. Normally, all spark plugs from the same engine should have the same color on the white insulator around the center electrode. The ideal color at this point is a medium-to-light tan color for a motorcycle that is being ridden normally. If one spark plug shows a distinctly different color, there could be something wrong with the engine.

Do not attempt to diagnose such problems yourself. Instead, take the motorcycle to a Yamaha dealer. You should periodically remove and inspect the spark plugs because heat and deposits will cause any spark plug to slowly break down and erode. If electrode erosion becomes excessive, or if carbon and other deposits are excessive, you should replace the spark plug with the specified plug.

Specified spark plug:  
DPR7EA-9 (NGK) or  
X22EPR-U9 (DENSO)

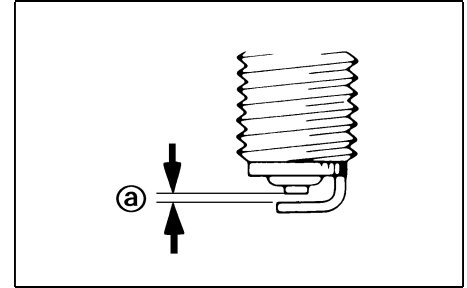

a. Spark plug gap

## Installation

1. Measure the electrode gap with a wire thickness gauge and, if necessary, adjust the gap to specification.

Spark plug gap:  
0.8 ~ 0.9 mm

2. Clean the gasket surface. Wipe off any grime from the threads.
3. Install the spark plug and tighten it to the specified torque.

# PERIODIC MAINTENANCE AND MINOR REPAIR

Tightening torque:  
Spark plug:  
18 Nm (1.8 m·kg)

**NOTE:** \_\_\_\_\_  
If a torque wrench is not available when you are installing a spark plug, a good estimate of the correct torque is 1/4 to 1/2 turn past finger tight. Have the spark plug tightened to the specified torque as soon as possible.

4. Install the spark plug caps.

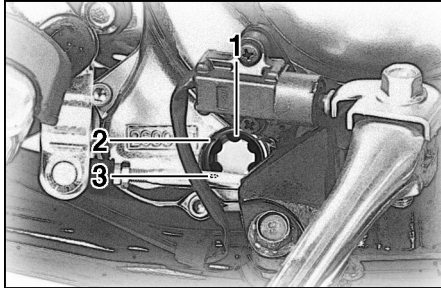

1. Oil level window
2. Maximum level mark
3. Minimum level mark

EAU01326\*

## Engine oil Oil level inspection

1. Place the motorcycle on a level place and hold it in an upright position. Warm up the engine for several minutes.

**NOTE:** \_\_\_\_\_  
Be sure the motorcycle is positioned straight up when checking the oil level. A slight tilt toward the side can result in false readings.

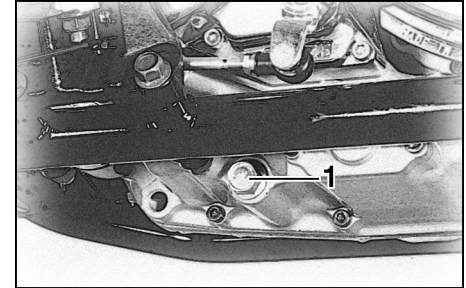

1. Engine oil drain bolt
2. With the engine stopped, check the oil level through the level window located at the lower part of the left side crankcase cover.

**NOTE:** \_\_\_\_\_  
Wait a few minutes until the oil level settles before checking.

3. The oil level should be between the maximum and minimum marks. If the level is low, fill the engine with sufficient oil to the specified level.

# PERIODIC MAINTENANCE AND MINOR REPAIR

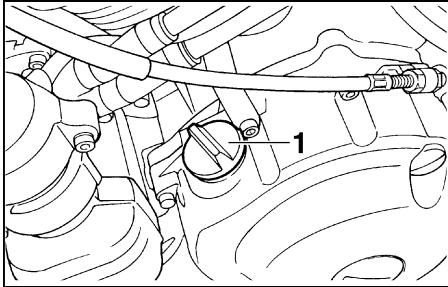

1. Engine oil filler cap

## Engine oil and oil filter element replacement

1. Warm up the engine for a few minutes.
2. Stop the engine. Place an oil pan under the engine and remove the oil filler cap.
3. Remove the drain bolt and drain the oil.

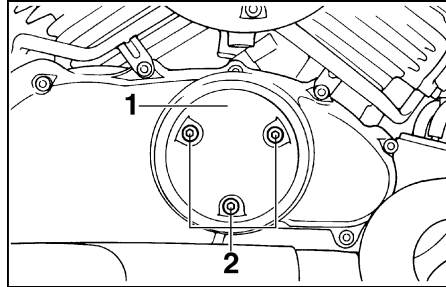

1. Cover  
2. Bolt (× 3)

4. Remove the cover and the oil filter cover by removing the bolts.
5. Remove the oil filter and O-ring.
6. Reinstall the drain bolt and tighten it to the specified torque.

Tightening torque:  
Drain bolt:  
43 Nm (4.3 m·kg)

7. Install a new oil filter and O-ring.

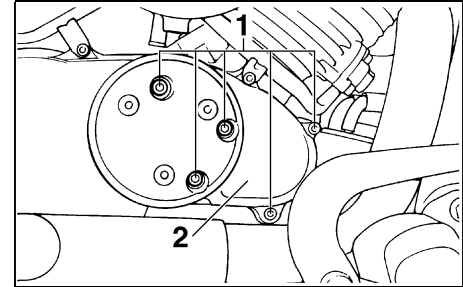

1. Bolt (× 5)  
2. Oil filter cover

8. Install oil filter cover and cover, then tighten the bolts.
9. Fill the engine with oil. Install the oil filler cap and tighten it.

Recommended oil:

See page 8-1.

Oil quantity:

Total amount:

3.2 L

Periodic oil change:

2.6 L

With oil filter replacement:

2.8 L



# PERIODIC MAINTENANCE AND MINOR REPAIR

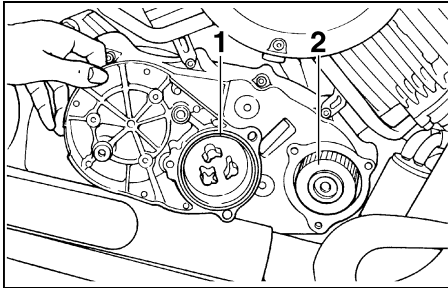

1. O-ring
2. Oil filter element

EC000066

## CAUTION:

- Do not put in any chemical additives. Engine oil also lubricates the clutch and additives could cause clutch slippage.
- Be sure no foreign material enters the crankcase.

10. Start the engine and warm it up for a few minutes. While warming up, check for oil leakage. If oil leakage is found, stop the engine immediately and check for the cause.

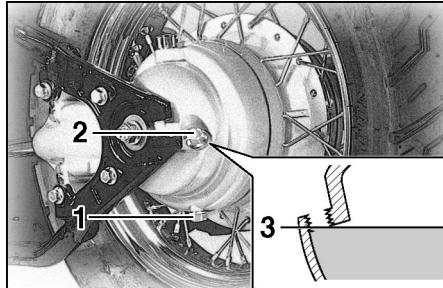

1. Final gear oil drain bolt
2. Final gear oil filler bolt
3. Proper level

EAU02943

EW000066

## Final gear oil



**Do not let foreign material enter the final gear case. Be sure oil does not get on the tire or wheel.**

## Oil level inspection

1. Place the motorcycle on a level place and hold it in an upright position. The engine should be cool at ambient temperature.

2. Remove the oil filler bolt and check the oil level. The oil level should be at the brim of the filler hole. Add the recommended oil if necessary.

## Oil replacement

1. Place an oil pan under the final gear case.
2. Remove the oil filler bolt and drain bolt to drain the oil.
3. Install and tighten the drain bolt to the specified torque.

Tightening torque:

Drain bolt:

23 Nm (2.3 m·kg)

4. Fill the gear case to the brim of the filler hole with the recommended oil.

# PERIODIC MAINTENANCE AND MINOR REPAIR

Final gear case capacity:  
0.19 L

Recommended oil:

SAE 80 API GL-4 Hypoid gear oil  
If desired, an SAE 80W90 hypoid gear oil may be used for all conditions.

## NOTE:

“GL-4” is a quality and additive rating. Hypoid gear oils rated “GL-5” or “GL-6” may also be used.

5. Install and tighten the filler bolt to the specified torque.

Tightening torque:

Oil filler bolt:  
23 Nm (2.3 m·kg)

6. After replacing the final gear oil, be sure to check for oil leakage.

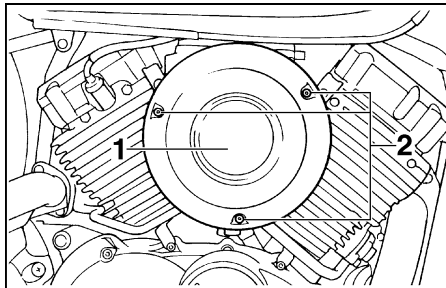

1. Case cover
2. Screw (× 3)

EAU00586

## Air filter

The air filter should be cleaned at the specified intervals. It should be cleaned more frequently if you are riding in unusually wet or dusty areas.

1. Remove the air filter case cover by removing the screws.
2. Remove the air filter.

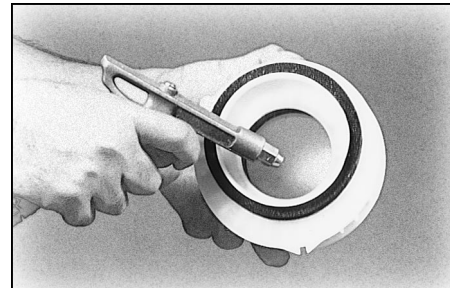

3. Tap the air filter lightly to remove most of the dust and dirt. Blow out the remaining dirt with compressed air as shown. If the air filter is damaged, replace it.

# PERIODIC MAINTENANCE AND MINOR REPAIR

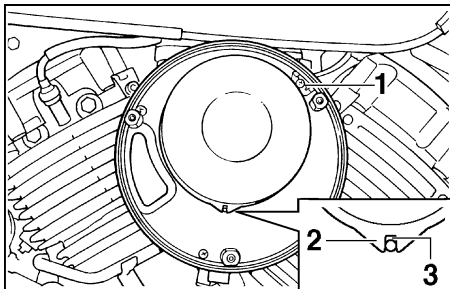

1. Holder
2. Projection
3. Slot

4. Install the air filter on the air filter case as shown.

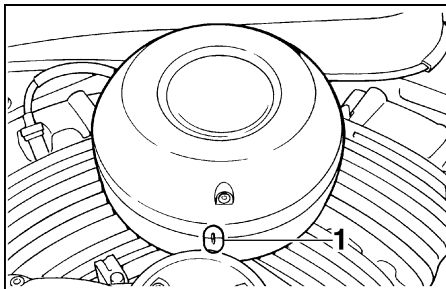

1. Match marks
5. Align the match marks and install the air filter case cover.

EC000082

## CAUTION:

- Make sure the air filter is properly seated in the air filter case.
- The engine should never be run without the air filter installed. Excessive piston and/or cylinder wear may result.

EAU00630

## Carburetor adjustment

The carburetors are important parts of the engine and require very sophisticated adjustment. Most adjustments should be left to a Yamaha dealer who has the professional knowledge and experience to do so. However, the idle speed may be adjusted by the owner as part of routine maintenance.

EC000095

## CAUTION:

The carburetors were set at the Yamaha factory after many tests. If they are changed, poor engine performance and damage may result.

## Idle speed adjustment

EAU01168

### NOTE:

A diagnostic tachometer must be used for this procedure.

1. Attach the tachometer. Start the engine and warm it up for a few minutes at approximately 1,000 to 2,000 r/min. Occasionally rev the engine to 4,000 to 5,000 r/min. The engine is warm when it quickly responds to the throttle.

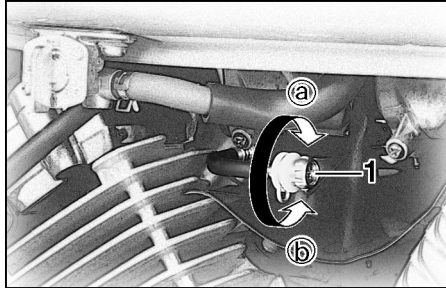

1. Throttle stop screw

2. Set the idle to the specified engine speed by adjusting the throttle stop screw. Turn the screw in direction (a) to increase engine speed and in direction (b) to decrease engine speed.

Standard idle speed:  
1,150 ~ 1,250 r/min

### NOTE:

If the specified idle speed cannot be obtained by performing the above adjustment, consult a Yamaha dealer.

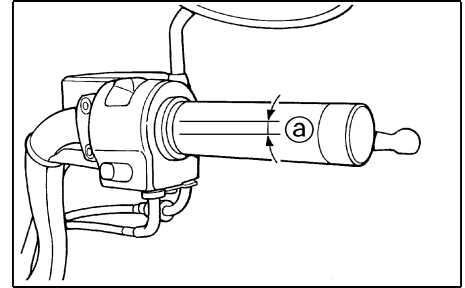

a. Free play

EAU00635

## Throttle cable free play inspection

There should be a free play of 4 ~ 6 mm at the throttle grip. If the free play is incorrect, ask a Yamaha dealer to make this adjustment.

# PERIODIC MAINTENANCE AND MINOR REPAIR

EAU00637

## Valve clearance adjustment

The correct valve clearance changes with use, resulting in improper fuel/air supply or engine noise. To prevent this, the valve clearance must be adjusted regularly. This adjustment however, should be left to a professional Yamaha service technician.

EAU01543\*

## Tires

To ensure maximum performance, long service and safe operation, note the following:

### Tire air pressure

Always check and adjust the tire pressure before operating the motorcycle.

EW000082



**Tire inflation pressure should be checked and adjusted when the temperature of the tire equals the ambient air temperature. Tire inflation pressure must be adjusted according to total weight of cargo, rider, passenger, and accessories (fairing, saddlebags, etc. if approved for this model), and vehicle speed.**

## XVS650

Maximum load*	180 kg	
Cold tire pressure	Front	Rear
Up to 90 kg load*	200 kPa (2.00 kgf/cm <sup>2</sup> , 2.00 bar)	225 kPa (2.25 kgf/cm <sup>2</sup> , 2.25 bar)
90 kg load ~ Maximum load*	200 kPa (2.00 kgf/cm <sup>2</sup> , 2.00 bar)	250 kPa (2.50 kgf/cm <sup>2</sup> , 2.50 bar)

\* Load is the total weight of cargo, rider, passenger and accessories.

## XVS650A

Maximum load*	201 kg	
Cold tire pressure	Front	Rear
Up to 90 kg load*	225 kPa (2.25 kgf/cm <sup>2</sup> , 2.25 bar)	225 kPa (2.25 kgf/cm <sup>2</sup> , 2.25 bar)
90 kg load ~ Maximum load*	225 kPa (2.25 kgf/cm <sup>2</sup> , 2.25 bar)	250 kPa (2.50 kgf/cm <sup>2</sup> , 2.50 bar)

\* Load is the total weight of cargo, rider, passenger and accessories.

# PERIODIC MAINTENANCE AND MINOR REPAIR

EW000083

## ⚠ WARNING

Proper loading of your motorcycle is important for several characteristics of your motorcycle, such as handling, braking, performance and safety. Do not carry loosely packed items that can shift. Securely pack your heaviest items close to the center of the motorcycle, and distribute the weight evenly from side to side. Properly adjust the suspension for your load, and check the condition and pressure of your tires. **NEVER OVERLOAD YOUR MOTORCYCLE.** Make sure the total weight of the cargo, rider, passenger, and accessories (fairing, saddlebags, etc. if approved for this model) does not exceed the maximum load of the motorcycle. Operation of an overloaded motorcycle could cause tire damage, an accident, or even injury.

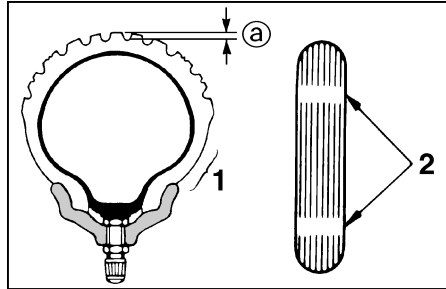

1. Side wall
2. Wear indicator
  - a. Tread depth

### Tire inspection

Always check the tires before operating the motorcycle. If a tire tread shows crosswise lines (minimum tread depth), if the tire has a nail or glass fragments in it, or if the side wall is cracked, contact a Yamaha dealer immediately and have the tire replaced.

### FRONT: XVS650

Manufacturer	Size	Type
Bridgestone	100/90-19 57S	L309
Dunlop	100/90-19 57S	F24

### REAR: XVS650

Manufacturer	Size	Type
Bridgestone	170/80-15M/C 77S	G546
Dunlop	170/80-15M/C 77S	K555

### FRONT: XVS650A

Manufacturer	Size	Type
Bridgestone	130/90-16 67S	G703
Dunlop	130/90-16 67S	D404F

### REAR: XVS650A

Manufacturer	Size	Type
Bridgestone	170/80-15M/C 77S	G702
Dunlop	170/80-15M/C 77S	D404

Minimum tire tread depth (front and rear)	1.0 mm
---	--------

### NOTE:

These limits may be different by regulation from country to country. If so, conform to the limits specified by the regulations of your own country.

# PERIODIC MAINTENANCE AND MINOR REPAIR

EAU00680

## ⚠ WARNING

- It is dangerous to ride with a worn-out tire. When a tire tread begins to show lines, have a Yamaha dealer replace the tire immediately. Brakes, tires, and related wheel parts replacement should also be left to a Yamaha dealer.
- Patching a punctured tube is not recommended. If it is absolutely necessary to do so, use great care and replace the tube as soon as possible with a good quality replacement.

6

## Wheels

To ensure maximum performance, long service, and safe operation, note the following:

- Always inspect the wheels before a ride. Check for cracks, bends or warpage of the wheel. Be sure the spokes are tight and undamaged. If any abnormal condition exists in a wheel, consult a Yamaha dealer. Do not attempt even small repairs to the wheel. If a wheel is deformed or cracked, it must be replaced.
- Tires and wheels should be balanced whenever either one is changed or replaced. Failure to have a wheel balanced can result in poor performance, adverse handling characteristics, and shortened tire life.
- Ride at moderate speeds after changing a tire since the tire surface must first be broken in for it to develop its optimal characteristics.

EAU00685

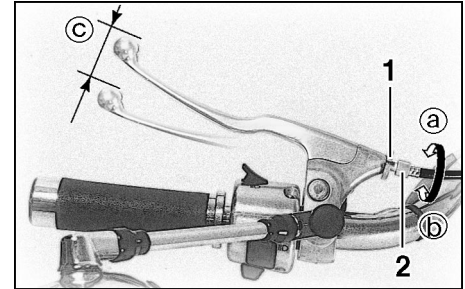

1. Locknut
2. Adjusting bolt
- c. Free play

EAU00694

## Clutch lever free play adjustment

The clutch lever free play should be adjusted to 10 ~ 15 mm.

1. Loosen the locknut at the clutch lever.
2. Turn the adjusting bolt at the clutch lever in direction (a) to increase free play or in direction (b) to decrease free play.
3. Tighten the locknut at the clutch lever.

# PERIODIC MAINTENANCE AND MINOR REPAIR

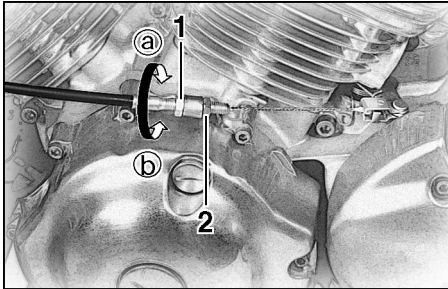

1. Adjusting nut
2. Locknut

If the specified free play cannot be obtained, proceed with the following steps.

4. Loosen the locknut at the clutch lever.
5. Turn the adjusting bolt at the clutch lever in direction (a) to loosen the cable.
6. Loosen the locknut at the crankcase side.
7. Turn the adjusting nut at the crankcase in direction (a) to increase free play or in direction (b) to decrease free play.
8. Tighten the locknut at the crankcase and the clutch lever.

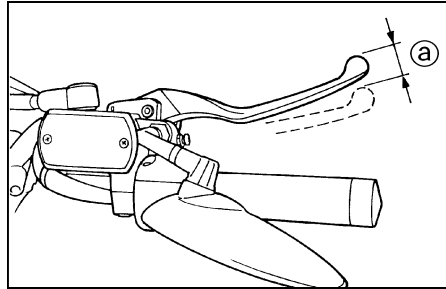

- a. Free play

EAU00696

## Front brake lever free play adjustment

The free play at the front brake lever should be 10 ~ 15 mm.

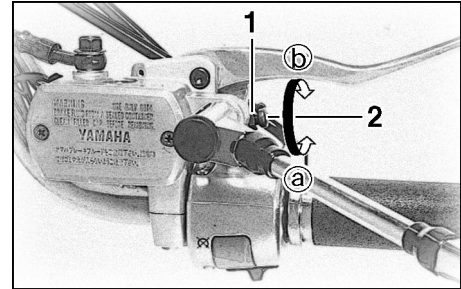

1. Locknut
2. Adjusting bolt

1. Loosen the locknut.
2. Turn the adjusting bolt in direction (a) to increase free play or in direction (b) to decrease free play.
3. After adjusting, tighten the locknut.



# PERIODIC MAINTENANCE AND MINOR REPAIR

EW000099

## ⚠ WARNING

- Check the brake lever free play. Be sure the brake is working properly.
- A soft or spongy feeling in the brake lever can indicate the presence of air in the brake system. This air must be removed by bleeding the brake system before the motorcycle is operated. Air in the system will cause greatly diminished braking capability and can result in loss of control and an accident. Have a Yamaha dealer inspect and bleed the system if necessary.

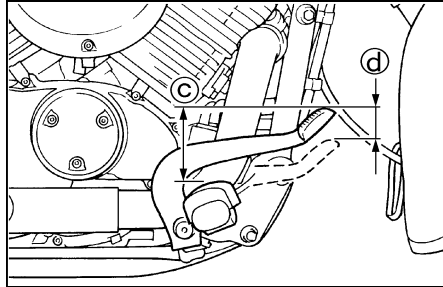

- c. Pedal height
- d. Free play

## Rear brake pedal height and free play adjustment

EAU00711

EW000104

## ⚠ WARNING

It is advisable to have a Yamaha dealer make this adjustment.

The brake pedal height should be adjusted before adjusting the brake pedal free play.

### Pedal height

The brake pedal should be positioned approximately 85 mm above the top of the footrest.

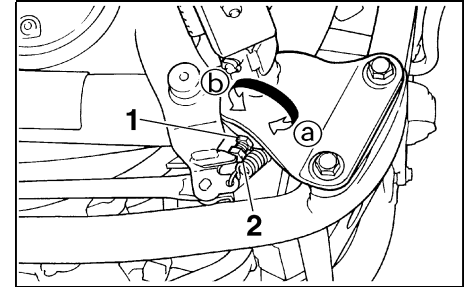

- 1. Locknut
- 2. Adjusting bolt

1. Loosen the locknut.
2. Turn the adjusting bolt in direction **a** to raise pedal height or in direction **b** to lower pedal height.
3. Tighten the locknut.

# PERIODIC MAINTENANCE AND MINOR REPAIR

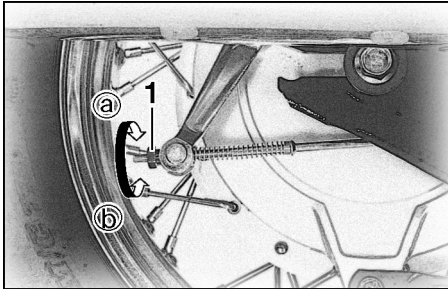

1. Adjusting nut

EW000105

## **⚠ WARNING**

**After adjusting the pedal height, adjust brake pedal free play.**

### **Free play**

The brake pedal free play should be adjusted to 20 ~ 30 mm at the brake pedal end. Turn the adjusting nut on the brake rod in direction ① to increase free play or in direction ② to decrease free play.

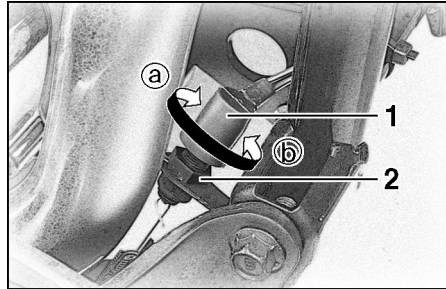

1. Brake light switch  
2. Adjusting nut

EAU00713

### **Brake light switch adjustment**

The rear brake light switch is activated by the brake pedal and is properly adjusted when the brake light comes on just before braking takes effect. To adjust the rear brake light switch, hold the switch body so it does not rotate while turning the adjusting nut. Turn the adjusting nut in direction ① to make the brake light come on earlier.

Turn the adjusting nut in direction ② to make the brake light come on later.

# PERIODIC MAINTENANCE AND MINOR REPAIR

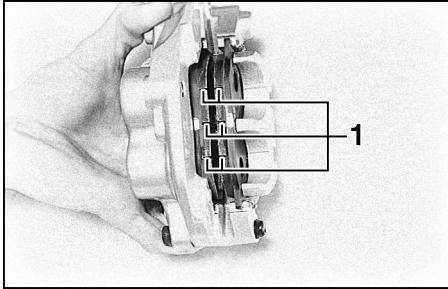

1. Wear indicator grooves

EAU00720

## Checking the front brake pads and rear brake shoes

6

### Front brake

EAU01119

Wear indicator grooves are provided on each brake pad. These indicators allow checking of brake pad wear without disassembling the brake. Inspect the grooves. If they have almost disappeared, ask a Yamaha dealer to replace the pads.

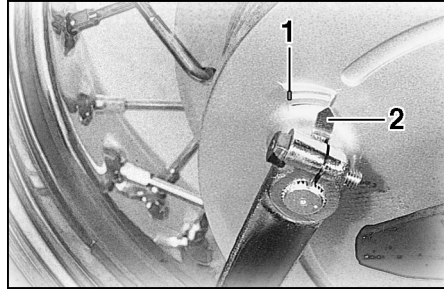

1. Wear limit line  
2. Wear indicator

EAU00727

### Rear brake

Apply the brake and inspect the wear indicator.

If the indicator reaches the wear limit line, ask a Yamaha dealer to replace the shoes.

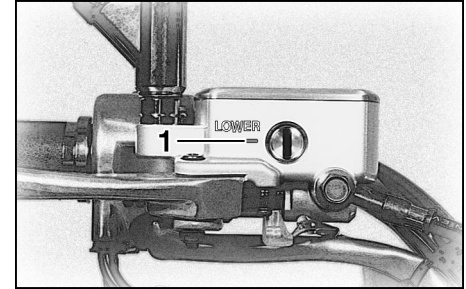

1. Minimum level mark

EAU00731

## Inspecting the brake fluid level

Insufficient brake fluid may let air enter the brake system, possibly causing the brakes to become ineffective.

Before riding, check that the brake fluid is above the minimum level and replenish when necessary.

Observe these precautions:

- When checking the fluid level, make sure the top of the master cylinder is level by turning the handlebars.

# PERIODIC MAINTENANCE AND MINOR REPAIR

- Use only the designated quality brake fluid. Otherwise, the rubber seals may deteriorate, causing leakage and poor brake performance.

Recommended brake fluid: DOT 4

- Refill with the same type of brake fluid. Mixing fluids may result in a harmful chemical reaction and lead to poor brake performance.
- Be careful that water does not enter the master cylinder when refilling. Water will significantly lower the boiling point of the fluid and may result in vapor lock.
- Brake fluid may deteriorate painted surfaces or plastic parts. Always clean up spilled fluid immediately.
- Have a Yamaha dealer check the cause if the brake fluid level goes down.

## Brake fluid replacement

EAU00742

The brake fluid should be replaced only by trained Yamaha service personnel. Have the Yamaha dealer replace the following components during periodic maintenance or when they are damaged or leaking:

- oil seals (every two years)
- brake hoses (every four years)

## Cable inspection and lubrication

EAU02962

EW000112

### **WARNING**

**Damage to the outer housing of cables may lead to internal rusting and interfere with the cable movement. Replace damaged cables as soon as possible to prevent unsafe conditions.**

Lubricate the cables and cable ends. If a cable does not operate smoothly, ask a Yamaha dealer to replace it.

Recommended lubricant:  
Engine oil

# PERIODIC MAINTENANCE AND MINOR REPAIR

## Throttle cable and grip lubrication

EAU00773

The throttle twist grip assembly should be greased at the time that the cable is lubricated, since the grip must be removed to get at the end of the throttle cable. After removing the screws, hold the end of the cable up in the air and put in several drops of lubricant. With the throttle grip disassembled, coat the metal surface of the grip assembly with a suitable all-purpose grease.

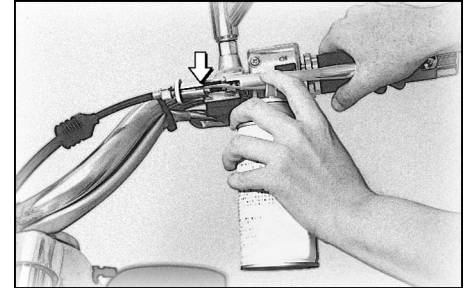
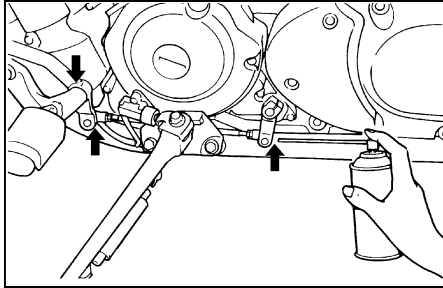

## Brake and shift pedal lubrication

EAU02984

Lubricate the pivoting parts.

Recommended lubricant:  
Engine oil

## Brake and clutch lever lubrication

EAU02985

Lubricate the pivoting parts.

Recommended lubricant:  
Engine oil

# PERIODIC MAINTENANCE AND MINOR REPAIR

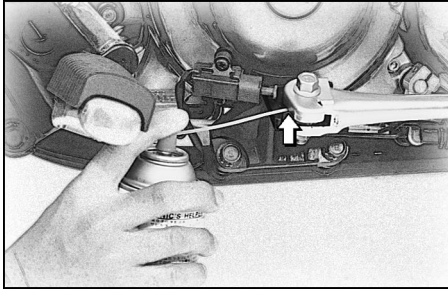

EAU02986

## Sidestand lubrication

Lubricate the sidestand pivoting point and metal-to-metal contact surfaces. Check that the sidestand moves up and down smoothly.

Recommended lubricant:  
Engine oil

EW000113

### **⚠ WARNING**

**If the sidestand does not move smoothly, consult a Yamaha dealer.**

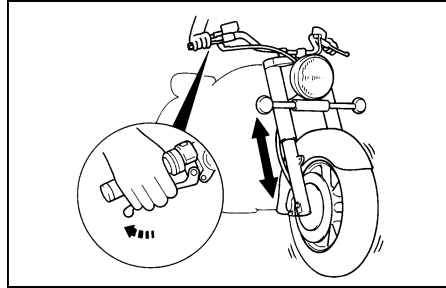

EAU02939

## Front fork inspection

### Visual check

EW000115

### **⚠ WARNING**

**Securely support the motorcycle so there is no danger of it falling over.**

Check for scratches or damage on the inner tube and excessive oil leakage from the front fork.

### Operation check

1. Place the motorcycle on a level place.
2. Hold the motorcycle in an upright position and apply the front brake.

3. Push down hard on the handlebars several times and check if the fork rebounds smoothly.

EC000098

### **CAUTION:**

**If any damage or unsmooth movement is found with the front fork, consult a Yamaha dealer.**

# PERIODIC MAINTENANCE AND MINOR REPAIR

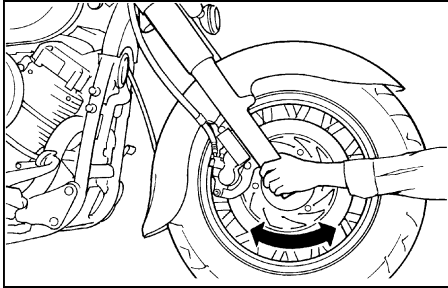

EAU00794

## Steering inspection

Periodically inspect the condition of the steering. Worn out or loose steering bearings may be dangerous. Place a stand under the engine to raise the front wheel off the ground. Hold the lower end of the front forks and try to move them forward and backward. If any free play can be felt, ask a Yamaha dealer to inspect and adjust the steering. Inspection is easier if the front wheel is removed.

EW000115

### **! WARNING**

**Securely support the motorcycle so there is no danger of it falling over.**

EAU01144

## Wheel bearings

If there is play in the front or rear wheel hub or if the wheel does not turn smoothly, have a Yamaha dealer inspect the wheel bearings.

EAU00800

## Battery

This motorcycle is equipped with a sealed-type battery. Therefore it is not necessary to check the electrolyte or fill the battery with distilled water.

- If the battery seems to have discharged, consult a Yamaha dealer.
- If the motorcycle is equipped with optional electrical accessories, the battery tends to discharge more quickly, so be sure to recharge it periodically.

EC000101

### **CAUTION:**

**Never try to remove the sealing caps of the battery cells. The battery will be damaged.**

# PERIODIC MAINTENANCE AND MINOR REPAIR

EW000116

## **⚠ WARNING**

**Battery electrolyte is poisonous and dangerous, causing severe burns, etc. It contains sulfuric acid. Avoid contact with skin, eyes or clothing.**

### **ANTIDOTE:**

- **EXTERNAL:** Flush with water.
- **INTERNAL:** Drink large quantities of water or milk. Follow with milk of magnesia, beaten egg, or vegetable oil. Call a physician immediately.
- **EYES:** Flush with water for 15 minutes and get prompt medical attention.

Batteries produce explosive gases. Keep sparks, flame, cigarettes etc., away. Ventilate when charging or using in an enclosed space. Always shield your eyes when working near batteries.

**KEEP OUT OF REACH OF CHILDREN.**

## **Battery storage**

When the motorcycle is not used for a month or longer, remove the battery, fully charge it and store it in a cool, dry place.

EC000102

## **CAUTION:**

- **Completely recharge the battery before storing. Storing a discharged battery can cause permanent battery damage.**
- **Use a battery charger designed for a sealed-type (MF) battery. Using a conventional battery charger will cause battery damage. If you do not have a sealed-type battery charger, contact your Yamaha dealer.**
- **Always make sure the connections are correct when reinstalling the battery.**



# PERIODIC MAINTENANCE AND MINOR REPAIR

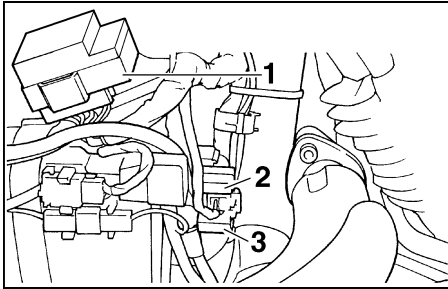

1. Fuse block
2. Main fuse
3. Spare fuse

EAU00825

## Fuse replacement

The fuses are located behind panel A. (See page 6-6 for panel removal procedures.)

If a fuse is blown, turn off the main switch and the switch of the circuit in question. Install a new fuse of proper amperage. Turn on the switches and see if the electrical device operates. If the fuse immediately blows again, consult a Yamaha dealer.

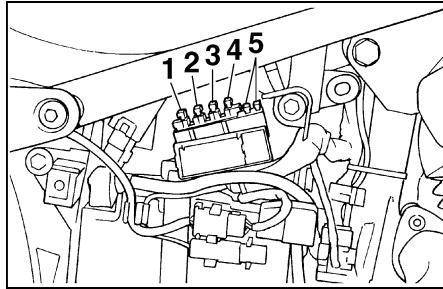

1. Ignition fuse
2. Signaling system fuse
3. Headlight fuse
4. Carburetor heater fuse
5. Spare fuse

EC000103

### **CAUTION:**

**Do not use fuses of higher amperage rating than those recommended. Substitution of a fuse of improper rating can cause extensive electrical system damage and possibly a fire.**

### Specified fuses:

Main fuse:	30 A
Ignition fuse:	10 A
Signaling system fuse:	10 A
Headlight fuse:	15 A
Carburetor heater fuse:	15 A

# PERIODIC MAINTENANCE AND MINOR REPAIR

EC000105

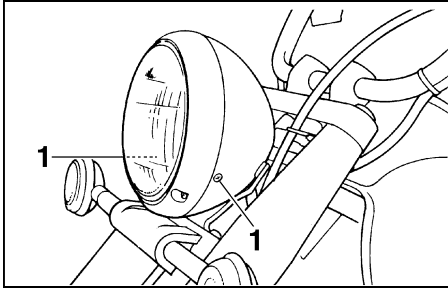

1. Screw (x 2)

EAU00833

## Headlight bulb replacement

This motorcycle is equipped with a quartz bulb headlight.

If the headlight bulb burns out, replace the bulb as follows:

1. Remove the headlight unit screws.
2. Remove the connectors, the headlight unit and then the bulb cover.

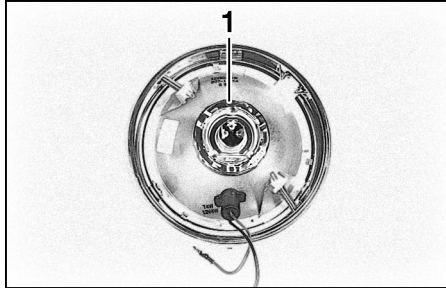

1. Bulb holder

3. Turn the bulb holder counterclockwise to remove it and remove the defective bulb.

EW000119

## WARNING

**Keep flammable products and your hands away from a bulb while it is on, as it is hot. Do not touch a bulb until it cools down.**

4. Put a new bulb into position and secure it in place with the bulb holder.

## CAUTION:

Avoid touching the glass part of a bulb. Keep it free from oil; otherwise, the transparency of the glass, life of the bulb, and luminous flux will be adversely affected. If oil gets on a bulb, thoroughly clean it with a cloth moistened with alcohol or lacquer thinner.

5. Install the bulb cover, connectors and headlight unit. Ask a Yamaha dealer to adjust the headlight beam if necessary.

# PERIODIC MAINTENANCE AND MINOR REPAIR

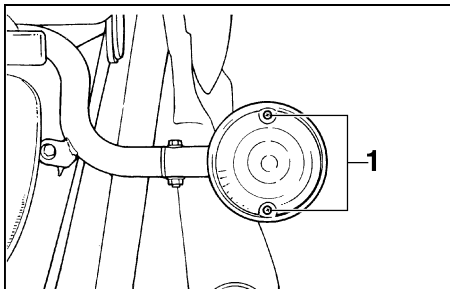

1. Screw (× 2)

EAU00855

## Turn signal and taillight bulb replacement

1. Remove the screws and the lens.
2. Push the bulb inward and turn it counterclockwise.

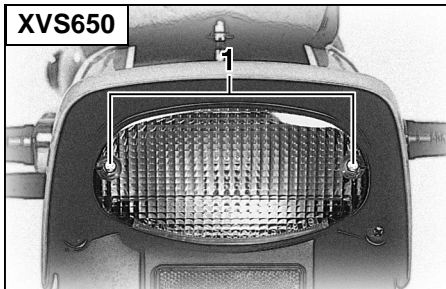

1. Screw (× 2)

3. Place a new bulb in the socket. Push the bulb inward and turn it clockwise until it engages into the socket.
4. Install the lens and the screws.

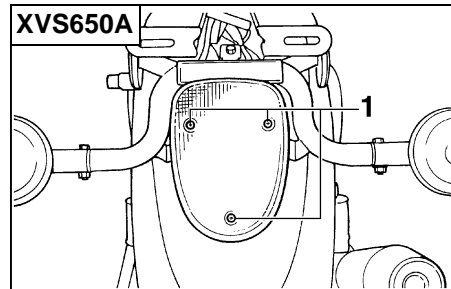

1. Screw (× 3)

EC000108

### CAUTION:

**Do not over-tighten the screws as the lens may break.**

EAU01579

## Supporting the motorcycle

Since the Yamaha XVS650/XVS650A has no centerstand, follow these precautions when removing the front and rear wheel or performing other maintenance requiring the motorcycle to stand upright. Check that the motorcycle is in a stable and level position before starting any maintenance. A strong wooden box can be placed under the engine for added stability.

## Front wheel service

To stabilize the rear of the motorcycle, either use a motorcycle stand or place a motorcycle jack under the frame in front of the rear wheel to prevent it from moving from side to side. Then use a motorcycle stand to elevate the front wheel off of the ground.

## Rear wheel service

Use a motorcycle stand or motorcycle jack to elevate the motorcycle so the rear wheel is off the ground. Alternatively, two jacks can be placed under the frame or swingarm.

# PERIODIC MAINTENANCE AND MINOR REPAIR

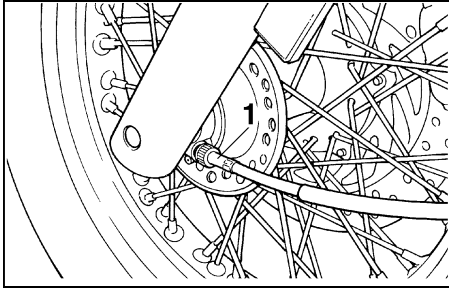

1. Speedometer cable

EAU00894

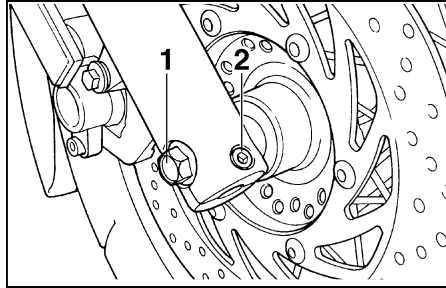

1. Axle  
2. Pinch bolt

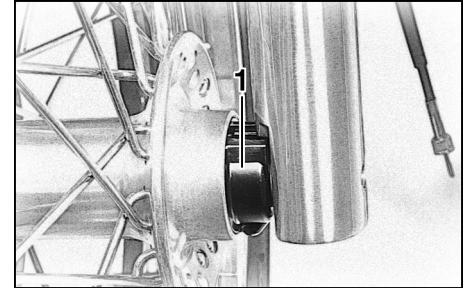

1. Speedometer gear unit housing

EAU01394

## Front wheel removal

EW000122

### **⚠ WARNING**

- It is advisable to have a Yamaha dealer service the wheel.
- Securely support the motorcycle so there is no danger of it falling over.

1. Remove the speedometer cable from the front wheel side.

2. Loosen the pinch bolt and wheel axle.
3. Elevate the front wheel by placing a suitable stand under the engine.
4. Remove the wheel axle and the front wheel.

### **NOTE:**

Do not depress the brake lever when the disc and caliper are separated.

## Front wheel installation

1. Install the speedometer gear unit into the wheel hub. Make sure the wheel hub and the speedometer gear unit are installed with the projections meshed into the slots.
2. Lift up the wheel between the front fork legs and guide the brake disc between the brake pads. Make sure the slot in the speedometer gear unit fits over the stopper on the front fork outer tube.
3. Install the wheel axle and let the motorcycle down.

# PERIODIC MAINTENANCE AND MINOR REPAIR

4. Push down hard on the handlebars several times to check for proper fork operation.
5. Tighten the wheel axle to the specified torque.
6. Install the pinch bolt and tighten it to the specified torque.

## Tightening torque:

Wheel axle:

59 Nm (5.9 m·kg)

Pinch bolt:

20 Nm (2.0 m·kg)

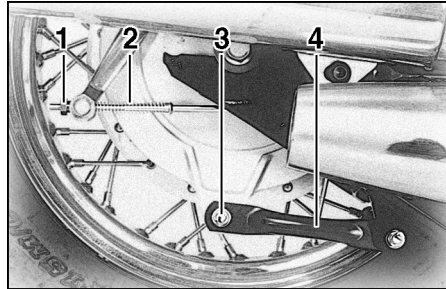

1. Brake pedal free play adjusting nut
2. Brake rod
3. Brake torque rod bolt
4. Brake torque rod

1. Loosen the axle nut. Do not remove it.
2. Remove the brake torque rod bolt on the brake shoe plate side.
3. Loosen the brake torque rod bolt on the swingarm side.
4. Remove the brake pedal free play adjusting nut and then the brake rod from the brake cam lever.
5. Remove panel "A". (See page 6-6 for removal procedures.)

EAU01350

## Rear wheel removal

EW000122

### **WARNING**

- It is advisable to have a Yamaha dealer service the wheel.
- Securely support the motorcycle so there is no danger of it falling over.

# PERIODIC MAINTENANCE AND MINOR REPAIR

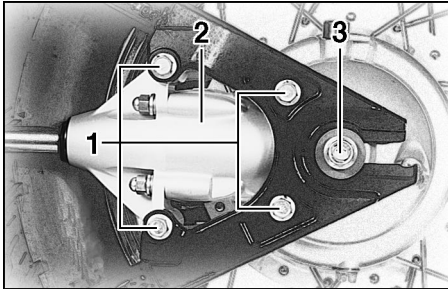

1. Bolt (× 4)
2. Final gear case
3. Axle nut

6. Remove the bolts that secure the final gear case to the swingarm.
7. Elevate the rear wheel off of the ground.
8. Pull the wheel backward while supporting the drive shaft to remove the wheel, axle, final gear case and drive shaft as an assembly.

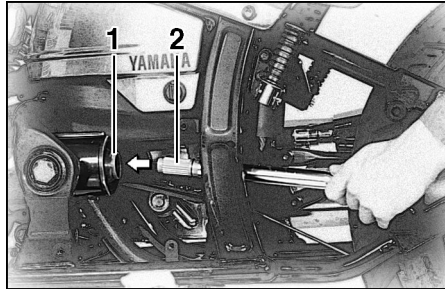

1. Middle drive shaft joint
2. Drive shaft

EAU01563

## Rear wheel installation

1. Install the rear wheel, axle, final gear case and drive shaft as an assembly by pushing the wheel forward and guiding the drive shaft into the middle drive shaft U-joint.
2. Install the bolts that secure the final gear case to the swingarm and tighten to the specified tightening torque.

Specified torque:  
Final gear case bolts:  
90 Nm (9.0 m·kg)

3. Insert the brake rod into the brake cam lever and install the brake pedal free play adjusting nut.
4. Install the brake torque rod bolt and tighten both bolts to the specified tightening torque.

Specified torque:  
Brake torque rod bolts:  
20 Nm (2.0 m·kg)

5. Install panel "B".
6. Let the motorcycle down.
7. Tighten the axle nut to the specified tightening torque.

Specified torque:  
Axle nut:  
92 Nm (9.2 m·kg)

8. Adjust the rear brake pedal free play. (See page 6-19.)

EAU01008

## Troubleshooting

Although Yamaha motorcycles receive a rigid inspection before shipment from the factory, trouble may occur during operation.

Any problem in the fuel, compression, or ignition systems can cause poor starting and loss of power. The troubleshooting chart describes a quick, easy procedure for making checks.

If your motorcycle requires any repair, bring it to a Yamaha dealer. The skilled technicians at a Yamaha dealership have the tools, experience, and know-how to properly service your motorcycle. Use only genuine Yamaha parts on your motorcycle. Imitation parts may look like Yamaha parts, but they are often inferior. Consequently, they have a shorter service life and can lead to expensive repair bills.



# PERIODIC MAINTENANCE AND MINOR REPAIR

## Troubleshooting chart

EAU01297\*

EW000125



**WARNING**

**Never check the fuel system while smoking or in the vicinity of an open flame.**

### 1. Fuel

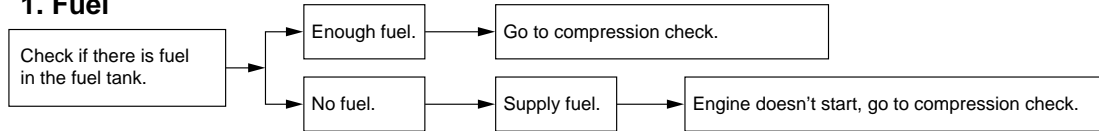

### 2. Compression

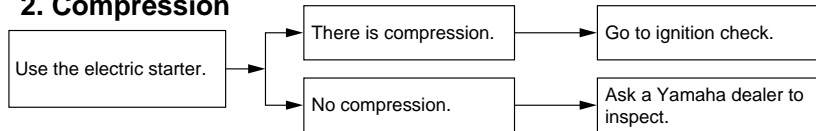

### 3. Ignition

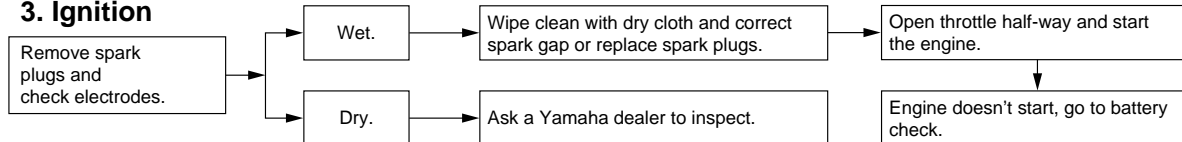

### 4. Battery

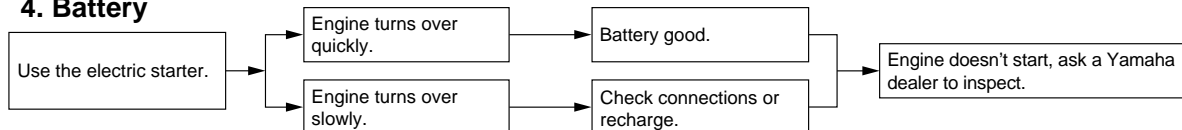

# MOTORCYCLE CARE AND STORAGE

---

---

Care .....	7-1
Storage.....	7-4

## Care

The exposure of its technology makes a motorcycle charming but also vulnerable. Although high-quality components are used, they are not all rust-resistant. While a rusty exhaust pipe may remain unnoticed on a car, it does look unattractive on a motorcycle. Frequent and proper care, however, will keep your motorcycle looking good, extend its life and maintain its performance. Moreover, the warranty states that the vehicle must be properly taken care of. For all these reasons, it is recommended that you observe the following cleaning and storing precautions.

## Before cleaning

1. Cover up the muffler outlets with plastic bags.
2. Make sure that all caps and covers as well as all electrical couplers and connectors, including the spark plug caps, are tightly installed.
3. Remove extremely stubborn dirt, like oil burnt onto the crankcase, with a degreasing agent and a brush, but never apply such products onto seals, gaskets and wheel axles. Always rinse the dirt and degreaser off with water.

## Cleaning

### After normal use

Remove dirt with warm water, a neutral detergent and a soft clean sponge, then rinse with plenty of clean water. Use a tooth or bottle brush for hard-to-reach parts. Tougher dirt and insects will come off more easily if the area is covered with a wet cloth for a few minutes before cleaning.

# MOTORCYCLE CARE AND STORAGE

ECA00010

## CAUTION:

- Avoid using strong acidic wheel cleaners, especially on spoked wheels. If you do use such products for hard-to-remove dirt, do not leave it on any longer than instructed, then thoroughly rinse it off with water, immediately dry the area and apply a corrosion protection spray.
- Improper cleaning can damage windshields, cowlings, panels and other plastic parts. Use only a soft, clean cloth or sponge with mild detergent and water to clean plastic.
- Do not use any harsh chemical products on plastic parts. Be sure to avoid using cloths or sponges which have been in contact with strong or abrasive cleaning products, solvent or thinner, fuel (gasoline), rust removers or inhibitors, brake fluid, antifreeze or electrolyte.
- Do not use high-pressure washers or steam-jet cleaners since they cause water seepage and deterioration in the following areas: seals (of wheel bearings, swingarm bearings, forks and brakes), electric components (couplers, connectors, instruments, switches and lights), breather hoses and vents.
- For motorcycles equipped with a windshield: Do not use strong cleaners or hard sponges as they will cause dulling or scratching. Some cleaning compounds for plastic may leave scratches on the windshield. Test the product on a small hidden part of the windshield to make sure they do not leave any marks. If the windshield is scratched, use a quality plastic polishing compound after washing.

After riding in the rain, near the sea or on salt-sprayed roads

Since sea salt or salt sprayed on the roads in the winter are extremely corrosive in combination with water, carry out the following steps after each ride in the rain, near the sea or on salt-sprayed roads. (Salt sprayed in the winter may remain on the roads well into spring.)

# MOTORCYCLE CARE AND STORAGE

---

---

1. Clean your motorcycle with cold water and soap after the engine has cooled down.

ECA00012

## **CAUTION:** \_\_\_\_\_

**Do not use warm water since it increases the corrosive action of the salt.**

---

2. Be sure to apply a corrosion protection spray on all (even chrome- and nickel-plated) metal surfaces to prevent corrosion.

## **After cleaning**

1. Dry the motorcycle with a chamois or an absorbing cloth.
2. Use a chrome polish to shine chrome, aluminum and stainless-steel parts, including the exhaust system. (Even the thermally induced discoloring of stainless-steel exhaust systems can be removed through polishing.)
3. To prevent corrosion, it is recommended to apply a corrosion protection spray on all (even chrome- and nickel-plated) metal surfaces.
4. Use spray oil as a universal cleaner to remove any remaining dirt.
5. Touch up minor paint damage caused by stones, etc.
6. Wax all painted surfaces.
7. Let the motorcycle dry completely before storing it or covering it.

EWA00001

## **! WARNING** \_\_\_\_\_

**Make sure that there is no oil or wax on the brakes and tires. If necessary, clean the brake discs and linings with a regular brake disc cleaner or acetone, and wash the tires with warm water and mild soap. Then, carefully test the motorcycle for its braking performance and cornering behavior.**

---

ECA00013

## **CAUTION:** \_\_\_\_\_

- **Apply spray oil and wax sparingly and wipe off any excess.**
  - **Never apply oil or wax on rubber and plastic parts, but treat them with a suitable care product.**
  - **Avoid using abrasive polishing compounds as they wear away the paint.**
- 

## **NOTE:** \_\_\_\_\_

Consult a Yamaha dealer for advice on what products to use.

---

# MOTORCYCLE CARE AND STORAGE

## Storage

### Short-term

Always store your motorcycle in a cool, dry place and, if necessary, protect it against dust with a porous cover.

ECA00014

### CAUTION:

- **Storing the motorcycle in a poorly ventilated room or covering it with a tarp while it is still wet will allow water and humidity to seep in and cause rust.**
- **To prevent corrosion, avoid damp cellars, stables (because of the presence of ammonia) and areas where strong chemicals are stored.**

### Long-term

Before storing your motorcycle for several months:

1. Follow all the instructions in the “Care” section of this chapter.
2. Drain the carburetor float chambers by loosening the drain bolts; this will prevent fuel deposits from building up. Pour the drained fuel into the fuel tank.
3. Only for motorcycles equipped with a fuel cock which has an “OFF” position: Turn the fuel cock to “OFF”.
4. Fill up the fuel tank and add fuel stabilizer (if available) to prevent the fuel tank from rusting and the fuel from deteriorating.
5. Perform the following steps to protect the cylinders, piston rings, etc. from corrosion.
  - a. Remove the spark plug caps and spark plugs.
  - b. Pour a teaspoonful of engine oil into each spark plug bore.

- c. Install the spark plug caps onto the spark plugs and place the spark plugs on the cylinder head so that the electrodes are grounded. (This will limit sparking during the next step.)
- d. Turn the engine over several times with the starter. (This will coat the cylinder walls with oil.)
- e. Remove the spark plug caps from the spark plugs, install the spark plugs and then the spark plug caps.

EWA00003

### **WARNING**

**When turning the engine over, be sure to ground the spark plug electrodes to prevent damage or injury from sparking.**

6. Lubricate all control cables and the pivoting points of all levers and pedals as well as of the sidestand/centerstand.

# MOTORCYCLE CARE AND STORAGE

---

---

7. Check and, if necessary, correct the tire air pressure, then raise the motorcycle so that both of its wheels are off the ground. Alternatively, turn the wheels a little every month in order to prevent the tires from becoming degraded in one spot.
8. Cover up the muffler outlets with plastic bags to prevent moisture from entering.
9. Remove the battery and fully charge it. Store it in a cool, dry place and recharge it once a month. Do not store the battery in an excessively cold or warm place (less than 0 °C or more than 30 °C). For more information, see “Battery storage” in the chapter “PERIODIC MAINTENANCE AND MINOR REPAIRS”.

**NOTE:** \_\_\_\_\_  
Make any necessary repairs before storing the motorcycle.  
\_\_\_\_\_

Specifications ..... 8-1  
HOW TO USE THE CONVERSION TABLE ..... 8-6



## Specifications

**Model** XVS650/XVS650A

### Dimensions

#### For XVS650

Overall length	2,340 mm
Overall width	880 mm
Overall height	1,065 mm
Seat height	695 mm
Wheelbase	1,610 mm
Ground clearance	140 mm
Minimum turning radius	3,100 mm

#### For XVS650A

Overall length	2,450 mm
Overall width	930 mm
Overall height	1,105 mm
Seat height	710 mm
Wheelbase	1,625 mm
Ground clearance	145 mm
Minimum turning radius	3,400 mm

### Basic weight (with oil and full fuel tank)

For XVS650	227 kg
For XVS650A	242 kg

### Engine

Engine type	Air-cooled 4-stroke, SOHC
Cylinder arrangement	V type 2-cylinder
Displacement	649 cm <sup>3</sup>
Bore × stroke	81 × 63 mm
Compression ratio	9:1
Starting system	Electric starter
Lubrication system	Wet sump

### Engine oil

#### Type

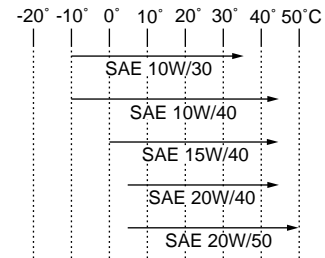

#### Recommended engine oil classification

API Service SE, SF, SG type or higher

**CAUTION:**

Be sure to use motor oils that do not contain anti-friction modifiers. Passenger car motor oils (often labeled “Energy Conserving”) contain anti-friction additives which will cause clutch and/or starter clutch slippage, resulting in reduced component life and poor engine performance.

**Quantity**

Periodic oil change	2.6 L
With oil filter replacement	2.8 L
Total amount	3.2 L

**Final gear oil**

Type	SAE80API “GL-4” Hypoid Gear Oil
Final gear case capacity	0.19 L

**Air filter**

Dry type element

**Fuel**

Type	Regular gasoline Unleaded fuel only (for Australia)
Fuel tank capacity	16 L
Fuel reserve amount	3 L

**Carburetor**

Type × quantity	BDS28 × 2
Manufacturer	MIKUNI

**Spark plug**

Type/Manufacturer	DPR7EA-9 / NGK or X22EPR-U9 / DENSO
-------------------	--

Gap	0.8 ~ 0.9 mm
-----	--------------

**Clutch type**

Wet, multiple-disc

**Transmission**

Primary reduction system	Spur gear
Primary reduction ratio	1.789
Secondary reduction system	Shaft drive
Secondary reduction ratio	3.071
Transmission type	Constant mesh 5-speed
Operation	Left foot operation
Gear ratio	
	1st 2.714
	2nd 1.900
	3rd 1.458
	4th 1.167
	5th 0.967

**Chassis**

**For XVS650**

Frame type	Double cradle
Caster angle	35°
Trail	153 mm

# SPECIFICATIONS

## For XVS650A

Frame type	Double cradle
Caster angle	35°
Trail	145 mm

## Tires

### For XVS650

Type	Tube
Front	
Size	100/90-19 57S
Manufacturer/model	Bridgestone / L309 Dunlop / F24
Rear	
Size	170/80-15 M/C 77S
Manufacturer/model	Bridgestone / G546 Dunlop / K555
Maximum load*	180 kg
Air pressure (cold tire)	
Up to 90 kg load*	
Front	200 kPa; 2.00 kgf/cm <sup>2</sup> ; 2.00 bar
Rear	225 kPa; 2.25 kgf/cm <sup>2</sup> ; 2.25 bar
90 kg load ~ maximum load*	
Front	200 kPa; 2.00 kgf/cm <sup>2</sup> ; 2.00 bar
Rear	250 kPa; 2.50 kgf/cm <sup>2</sup> ; 2.50 bar

## For XVS650A

Type	Tube
Front	
Size	130/90-16 67S
Manufacturer/model	Bridgestone / G703 Dunlop / D404F
Rear	
Size	170/80-15 M/C 77S
Manufacturer/model	Bridgestone / G702 Dunlop / D404
Maximum load*	201 kg
Air pressure (cold tire)	
Up to 90 kg load*	
Front	225 kPa; 2.25 kgf/cm <sup>2</sup> ; 2.25 bar
Rear	225 kPa; 2.25 kgf/cm <sup>2</sup> ; 2.25 bar
90 kg load ~ maximum load*	
Front	225 kPa; 2.25 kgf/cm <sup>2</sup> ; 2.25 bar
Rear	250 kPa; 2.50 kgf/cm <sup>2</sup> ; 2.50 bar

\* Load is total weight of cargo, rider, passenger and accessories.

## Wheels

### For XVS650

#### Front

Type	Spoke
Size	19 × MT2.50

#### Rear

Type	Spoke
Size	15M/C × MT3.50

### For XVS650A

#### Front

Type	Spoke
Size	16 × MT3.00

#### Rear

Type	Spoke
Size	15M/C × MT3.50

## Brakes

#### Front

Type	Single disc brake
Operation	Right hand operation
Fluid	DOT 4

#### Rear

Type	Drum brake
Operation	Right foot operation

## Suspension

#### Front

Type	Telescopic fork
------	-----------------

#### Rear

Type	Swingarm (monocross)
------	----------------------

## Shock absorber

#### Front

Coil spring / oil damper

#### Rear

Coil spring / gas-oil damper, spring preload adjustable

## Wheel travel

### For XVS650

Front 140 mm

Rear 86 mm

### For XVS650A

Front 140 mm

Rear 98 mm

## Electrical

### Ignition system

T.C.I. (digital)

### Charging system

Type A.C. magneto

Standard output 14 V, 20 A @ 5,000 r/min

### Battery

Type GT12B-4

Voltage, capacity 12 V, 10 AH

# SPECIFICATIONS

---

---

**Headlight type** Quartz bulb (halogen)

**Bulb voltage, wattage × quantity**

**For XVS650**

Headlight	12 V, 60/55 W × 1
Licence light	12 V, 5 W × 1
Tail/brake light	12 V, 5/21 W × 1
Turn signal light	12 V, 21 W × 4
Meter light	12 V, 1.7 W × 1
Neutral indicator light	12 V, 1.7 W × 1
High beam indicator light	12 V, 1.7 W × 1
Turn indicator light	12 V, 1.7 W × 1
Engine trouble indicator light	12 V, 1.7 W × 1

**For XVS650A**

Headlight	12 V, 60/55 W × 1
Licence light	12 V, 5 W × 1
Tail/brake light	12 V, 5/21 W × 1
Turn signal light	12 V, 21 W × 4
Meter light	12 V, 1.7 W × 1
Neutral indicator light	12 V, 1.7 W × 1
High beam indicator light	12 V, 1.7 W × 1
Turn indicator light	12 V, 1.7 W × 1
Engine trouble indicator light	12 V, 1.7 W × 1

**Fuses**

Main fuse	30 A
Ignition fuse	10 A
Signaling system fuse	10 A
Headlight fuse	15 A
Carburetor heater fuse	15 A

EAU01064

## HOW TO USE THE CONVERSION TABLE

All specification data in this manual are listed in SI and METRIC UNITS.

Use this table to convert METRIC unit data to IMPERIAL unit data.

Ex.

METRIC		MULTIPLIER		=	IMPERIAL
**mm	×	0.03937		=	**in
2 mm	×	0.03937		=	0.08 in

### CONVERSION TABLE

METRIC TO IMPERIAL			
	Metric unit	Multiplier	Imperial unit
Torque	m·kg	7.233	ft·lb
	m·kg	86.794	in·lb
	cm·kg	0.0723	ft·lb
	cm·kg	0.8679	in·lb
Weight	kg	2.205	lb
	g	0.03527	oz
Speed	km/hr	0.6214	mph
Distance	km	0.6214	mi
	m	3.281	ft
	m	1.094	yd
	cm	0.3937	in
	mm	0.03937	in
Volume / Capacity	cc (cm <sup>3</sup> )	0.03527	oz (IMP liq.)
	cc (cm <sup>3</sup> )	0.06102	cu-in
	lt (liter)	0.8799	qt (IMP liq.)
	lt (liter)	0.2199	gal (IMP liq.)
Misc.	kg/mm	55.997	lb/in
	kg/cm <sup>2</sup>	14.2234	psi (lb/in <sup>2</sup> )
	Centigrade (°C)	9/5 + 32	Fahrenheit (°F)



Identification number records.....	9-1
Key identification number .....	9-1
Vehicle identification number.....	9-1
Model label.....	9-2
Noise regulation (For Australia).....	9-2



## Identification number records

EAU02944

Record the key identification number, vehicle identification number and model label information in the spaces provided for assistance when ordering spare parts from a Yamaha dealer or for reference in case the vehicle is stolen.

### 1. KEY IDENTIFICATION NUMBER:

### 2. VEHICLE IDENTIFICATION NUMBER:

### 3. MODEL LABEL INFORMATION:

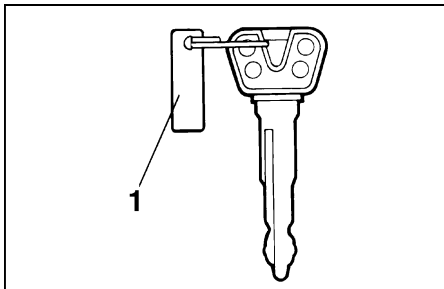

1. Key identification number

EAU01041

## Key identification number

The key identification number is stamped on the key tag. Record this number in the space provided and use it for reference when obtaining a new key.

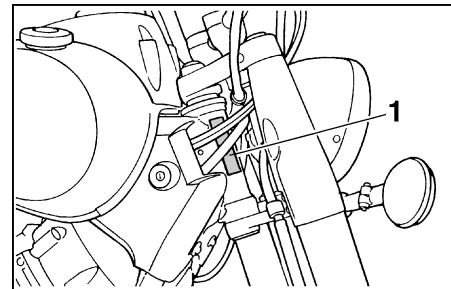

1. Vehicle identification number

EAU01043

## Vehicle identification number

The vehicle identification number is stamped into the steering head pipe. Record this number in the space provided.

### NOTE:

The vehicle identification number is used to identify your motorcycle and may be used to register your motorcycle with the licensing authority in your state.

EAU01388

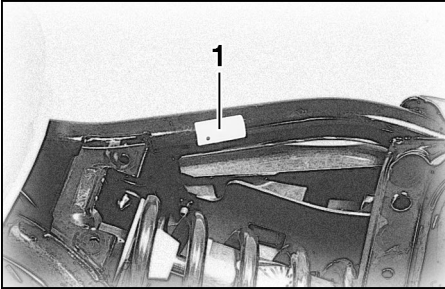

1. Model label

EAU01050

## Model label

The model label is affixed to the frame under the seat. (See page 3-9 for seat removal procedures.) Record the information on this label in the space provided. This information will be needed to order spare parts from your Yamaha dealer.

## NOISE REGULATION (For Australia)

### TAMPERING WITH NOISE CONTROL SYSTEM PROHIBITED

Owners are warned that the law may prohibit:

- (a) The removal or rendering inoperative by any person other than for purposes of maintenance, repair or replacement, of any device or element of design incorporated into any new vehicle for the purpose of noise control prior to its sale or delivery to the ultimate purchaser or while it is in use; and
- (b) The use of the vehicle after such device or element of design has been removed or rendered inoperative by any person.

# INDEX

## A

Air filter .....6-12

## B

Battery .....6-25

Brake and clutch lever lubrication.....6-23

Brake and shift pedal lubrication .....6-23

Brake fluid replacement .....6-22

Brake light switch adjustment.....6-20

## C

Cable inspection and lubrication .....6-22

Carburetor adjustment .....6-13

Care.....7-1

Checking the front brake pads and  
rear brake shoes.....6-21

Clutch lever.....3-4

Clutch lever free play adjustment .....6-17

Controls/Instruments  
(XVS650/XVS650A) .....2-5

## D

Dimmer switch .....3-3

## E

Engine break-in.....5-5

Engine oil .....6-9

Engine stop switch.....3-3

Engine trouble indicator light .....3-2

## F

Final gear oil.....6-11

Front brake lever .....3-5

Front brake lever free play  
adjustment .....6-18

Front fork inspection .....6-24

Front wheel installation .....6-31

Front wheel removal.....6-31

Fuel .....3-6

Fuel cock.....3-7

Fuel tank cap.....3-5

Fuse replacement.....6-27

## G

Gasoline and exhaust gas .....1-5

## H

Handlebar switches .....3-3

Dimmer switch .....3-3

Engine stop switch .....3-3

Horn switch .....3-3

Pass switch .....3-3

Start switch .....3-4

Turn signal switch .....3-3

Headlight bulb replacement .....6-28

Helmet holder .....3-11

High beam indicator light .....3-2

Horn switch .....3-3

## I

Identification number records .....9-1

Idle speed adjustment .....6-14

Indicator lights.....3-2

Engine trouble indicator light.....3-2

High beam indicator light .....3-2

Neutral indicator light .....3-2

Turn indicator light .....3-2

Inspecting the brake fluid level .....6-21

## K

Key identification number .....9-1

## L

Left view (XVS650) .....2-1

Left view (XVS650A) .....2-3

Loading and accessories .....1-3

Location of the important labels.....1-7

Luggage strap holders .....3-14

## M

Main switch/steering lock .....3-1

Model label .....9-2

Modification.....1-3

## N

Neutral indicator light .....3-2

Noise regulation (For Australia).....9-2

## P

Panel A.....	6-6
Panel B.....	6-7
Panel removal and installation.....	6-5
Parking.....	5-6
Pass switch.....	3-3
Periodic maintenance and lubrication.....	6-2
Pre-operation check list.....	4-1
Protective apparel.....	1-3

## R

Rear brake pedal.....	3-5
Rear brake pedal height and free play adjustment.....	6-19
Rear shock absorber adjustment.....	3-13
Rear wheel installation.....	6-33
Rear wheel removal.....	6-32
Right view (XVS650).....	2-2
Right view (XVS650A).....	2-4

## S

Safe riding.....	1-1
Seats (XVS650).....	3-9
Seats (XVS650A).....	3-10
Shifting.....	5-4
Shift pedal.....	3-4
Sidestand.....	3-14
Sidestand/clutch switch operation check.....	3-15
Sidestand lubrication.....	6-24
Spark plugs.....	6-7
Specifications.....	8-1
Speedometer.....	3-2
Starter (choke) “ ↘ ”.....	3-8

## Starting and warming up a cold

engine.....	5-1
Starting a warm engine.....	5-4
Start switch.....	3-4
Steering inspection.....	6-25
Storage.....	7-4
Storage compartment.....	3-11
Supporting the motorcycle.....	6-30

## T

Throttle cable and grip lubrication.....	6-23
Throttle cable free play inspection.....	6-14
Tips for reducing fuel consumption.....	5-5
Tires.....	6-15
Tool kit.....	6-1
Troubleshooting.....	6-34
Troubleshooting chart.....	6-35
Turn indicator light.....	3-2
Turn signal and taillight bulb replacement.....	6-29
Turn signal switch.....	3-3

## V

Valve clearance adjustment.....	6-15
Vehicle identification number.....	9-1

## W

Wheel bearings.....	6-25
Wheels.....	6-17



PRINTED ON RECYCLED PAPER

PRINTED IN JAPAN  
99 · 11 - 0.3 × 1 CR  
(E)